



Northumbria
University
NEWCASTLE



Proceedings of The Twentieth International Conference on Electronic Business *ICEB'20*

Hong Kong S.A.R., China
5-8 December 2020
ISSN: 1683-0040





Northumbria
University
NEWCASTLE



Proceedings of The Twentieth International Conference on Electronic Business

“Electronic Business under COVID-19 Pandemic”

Edited by

Eldon Y. Li

National Chung Cheng University, Taiwan and
Tongji University, Shanghai, China

Benjamin Yen

University of Hong Kong, Hong Kong S.A.R., China

ICEB'20

Hong Kong S.A.R., China
5-8 December 2020

ISSN: 1683-0040

Reference to this book should be made as follows: Li, E.Y. & Yen, B., Eds. (2020). *Proceedings of the 20th International Conference on Electronic Business* (ISSN: 1683-0040). ICEB'20, Hong Kong S.A.R., China, December 5-8, 506 pages.

COMMITTEES

Advisors:

International Consortium for Electronic Business, USA
International Journal of Electronic Business, UK
Journal of Business and Management, USA

Co-Organizers:

Faculty of Business and Economics, University of Hong Kong, Hong Kong S.A.R., China
Department of Computer and Information Sciences, Northumbria University in Newcastle Upon Tyne, UK

Conference Co-Chairs:

Eldon Y. Li, National Chung Cheng University, Taiwan and Tongji University, China
Benjamin Yen, University of Hong Kong, Hong Kong S.A.R., China

Program Co-Chairs:

Honglei Li, Northumbria University, UK
Ravi Sharma, University of Canterbury, NZ
Albert Huang, University of the Pacific, USA

Proceedings Co-Editors:

Eldon Y. Li, National Chung Cheng University, Taiwan and Tongji University, China
Benjamin Yen, University of Hong Kong, Hong Kong S.A.R., China

Best Paper Award Committee:

Albert Huang, University of the Pacific, USA
Ramayah Thurasamy, Universiti Sains Malaysia, Malaysia
Ravi Sharma, University of Canterbury, New Zealand
Timon C. Du, Chinese University of Hong Kong, Hong Kong S.A.R., China
Savvas Papagiannidis, Newcastle University, UK

International Program Committee & Editorial Board:

Abbas Tarhini, Lebanese American University, Lebanon
Albert Huang, University of the Pacific, USA
Benjamin Yen, University of Hong Kong, Hong Kong S.A.R., China
Cheng-Yuan (Cooper) Ku, National Chiao Tung University, Taiwan
Chengqi (John) Guo, James Madison University, USA
Chong Guan, Singapore University of Social Sciences, Singapore
Eldon Y. Li, National Chung Cheng University, Taiwan and Tongji University, China
Elena Vitkauskaite, Kaunas University of Technology, Lithuania
Honglei Li, Northumbria University, UK
Hsin-Lu Chang, National Chengchi University, Taiwan
Hu Xiong, University of Science and Technology of China, China
Ibrahim M. Al-Jabri, King Fahd University of Petroleum and Minerals, Saudi Arabia
Jao-Hong Cheng, National Yulin U. of Science and Technology, Taiwan
John Hamilton, James Cook University, Australia
Laddawan Kaewkitipong, Thammasat Business School, Thailand

Laurence F.K. Chang, Fang Chia University, Taiwan
Michael Chau, University of Hong Kong, Hong Kong S.A.R., China
Michel De Rougemont, University Paris II, France
Pei-Lee Teh, Monash University, Malaysia
Ramayah Thurasamy, Universiti Sains Malaysia, Malaysia
Ravi Sharma, University of Canterbury, New Zealand
Raylin Tso, National Chengchi University, Taiwan
Savvas Papagiannidis, Newcastle University, UK
Sim Kim Lau, University of Wollongong, Australia
Siriluck Rotchanakitumnuai, Thammasat University, Thailand
Timon C. Du, Chinese University of Hong Kong, Hong Kong S.A.R., China
Wei-Hsi (Frank) Hung, National Chengchi University, Taiwan
Waiman Cheung, Chinese University of Hong Kong, Hong Kong S.A.R., China
Wenshin Chen, Fang Chia University, Taiwan
Xiaoyu Xu, Xi'an Jiaotong University, China
Xudong (David) Luo, Guanxi Normal University, China
Yan Li, ESSEC Business School, Singapore
Yichuan Wang, Sheffield University Management School, UK
Yue Guo, King's College London, UK

PREFACE

Welcome to the very first International Conference on Electronic Business (ICEB 2020) virtual conference. Celebrating its 20th anniversary, the ICEB is held virtually this year by the University of Hong Kong, S.A.R. of China. The theme of this year's Conference is "*Electronic Business under COVID-19 Pandemic*". We received 71 submissions and 54 papers were accepted into the final program that consisted of 19 sessions. The topic areas of the papers in this conference include artificial intelligence, big data, blockchain, COVID-19 issues, E-collaboration, E-commerce, E-education, E-innovation, E-marketing, E-SCM, E-sustainability, IoT, social commerce, technological issues, and user behaviors, etc.



In the conference, we have scheduled four keynote speakers (in sequence of appearance): Prof. Patrick Y.K. Chau, the Chief Editor of *Information and Management*; Prof Dorothy E. Leidner, the Chief Editor of *Journal of Association for Information Systems*; Prof. Christy Cheung, the Chief Editor of *Internet Research*; Prof. Fred Phillips, the Chief Editor of

Technological Forecasting and Social Change. Because of the COVID-19 pandemic, all keynote speeches and presentations are delivered with the ZOOM software in two virtual meeting rooms. Unlike the previous years conducted in one day, the keynote speeches this year are scheduled across three days considering the time zone differences of the speakers in the U.S. Presentation sessions are also scheduled in a way that authors on the other continents are able to attend the meetings between 9 AM and 9 PM time frame.



The annual conference of ICEB is an excellent opportunity for the scholars like you and me to share research ideas and get informed about the latest development in the fields. We could meet leading scholars from around the world to establish a research network and engage in future collaborations. In this conference, there are 55 registered scholars from 15 countries or regions, including Australia, China, Germany, Hong Kong, Ireland, Lithuania, Malaysia, New Zealand, Portugal, Saudi Arabia, Singapore, Taiwan, Thailand, UAE, UK, USA. This year, the Best Paper Award Committee had selected 4 top-quality papers to receive the awards.

Finally, on behalf of the entire Conference Committee, we thank you all very much for participating in ICEB 2020 virtual conference, without you the conference it will not be successful. We also thank all the speakers, presenters, reviewers, the program committee members, Best Paper Award committee members, and session chairs, who all have contributed their time and effort to this conference. Special thanks go to Prof. Hongbin Cai, Dean of Business School at the University of Hong Kong, for supporting us with the conference secretariat, Ms. Queenie Shek, as well as an office colleague, Ms. Panda Tsu, and two IT staffs. They had provided the administrative and technical support to execute the ZOOM conference events flawlessly and effectively. Also, to Northumbria University, we thank Dr. Honglei Li and her colleagues to

manage the payment gateway. Last but not least, we thank you all for preparing and sharing your research findings in the meetings and look forward to seeing you again in ICEB 2021 in Bangkok.

Sincerely yours,

Eldon Y. Li

Eldon Y. Li
ICEB Honorary President
Distinguished Scholar
National Chung Cheng University, Chiayi, Taiwan
Chair Professor
Tongji University, Shanghai, China

Benjamin Yen

Benjamin Yen
ICEB 2020 Conference Co-Chair
Associate Professor
The University of Hong Kong, Hong Kong S.A.R., China

December 2020 in Hong Kong S.A.R., China

TABLE OF CONTENTS

TITLE	PAGE
Preface	i
<i>Eldon Y. Li, Benjamin Yen</i>	
 PART 1: Full Research Papers	
1. A comparative analysis between Airbnb and hotel industry: the investigation from China <i>Xiong Zhang* & Wenbo Liu</i>	1
2. A two-stage real-time prediction method for multiplayer shooting e-sports <i>Jiixin Liu, Jiixin Huang, Ruyun Chen, Tianchang Liu & Liang Zhou*</i>	9
3. Aging and urban mobility in Bandar Sunway: A holistic approach <i>Kasturi Rajandran, Muhammad Zarul Hanifah Md Zoqratt, Dexter Shee Zhen Rong, George Woon Lukic, Kristel Tan, Pei-Lee Teh, Deepa Alex, Vineetha Kalavally, Shaun Lee Wen Huey, Alexandre Rene Schaefer, Jamuna Jairaman, Wong Chieh Lee & Qasim Ayub</i>	19
4. Application of artificial intelligence technology in baby stroller design <i>Hou Jianjun & Xu Lijun</i>	29
5. Calm my headspace: Motivations and barriers for adoption and usage of meditation apps during times of crisis <i>Mackenzie Kellen & Deepak Saxena*</i>	37
6. Collaborative platform empowerment: Case study in the digital transformation of the interior design industry <i>Chia-Yu Jih* & Wei-Hsi Hung</i>	47
7. Comparative study of business models of European micro-mobility online services <i>Elena Vitkauskaitė* & Eglė Vaičiukynaitė</i>	55
8. Digital transformation research of Taiwan's traditional manufacturing industry based on the ecosystem perspectives <i>Chia-Yu Jih* & Wei-Hsi Hung</i>	63
9. Do users mind the brand engagement? The effect of brand engagement in knowledge sharing virtual community <i>Xiaobei Liang, Ruohong Hao & Hu Meng*</i>	71
10. Does COO matter in value co-creation of cross-border e-commerce? <i>Yan Ni*, Zhen Qin & Shumin Lv</i>	81
11. Dynamic perturbation Grasshopper Optimization Algorithm for engineering design problems <i>Yu Li, Xuechen Tu & Jingsen Liu*</i>	92
12. E-commerce and fashion retail industry: An empirical investigation on the online retail sector in the Gulf Cooperation Council (GCC) countries <i>Prakash Rao, Nitin Simha Vihari & Shazi Shah Jabeen</i>	110
13. Experiential learning through role-playing in the digital technology for business course <i>Mathupayas Thongmak</i>	119
14. Exploration of innovation and entrepreneurship education path for college students: A case study in the Guangdong-Hong Kong-Macao greater bay area <i>Xiao Bai, Huimin Xie, Yuxin Leng & Peiying Huang*</i>	128

15.	Guidance in the network jungle - A typology of inter-company innovation networks <i>Johannes Trenkle & Carl-Philipp Beichert*</i>	142
16.	How do price promotion and donation promotion affect consumers' impulsive buying behavior?: Based on face awareness and regulatory focus to the interaction of promotion patterns <i>Sujuan Song* & Wei Peng</i>	164
17.	Impact of corporate social responsibility on consumers' purchase behavior in the e-commerce environment <i>Li Xiaolin, Huang Dunhu* & Guo Mengqian</i>	173
18.	Impacts of competitive uncertainty and supply chain competence on big data analytics utilization: An information processing view <i>Wei Hsiu Weng</i>	181
19.	Improvement of market economy management measures for innovative enterprises under block chain technology <i>Xiuming Guan & Rongyu Zhang*</i>	191
20.	Internet of things utilization in marketing for competitive advantage: An organizational capability perspective <i>Wei Hsiu Weng</i>	200
21.	Issues and path selection of artificial intelligence design talents training in applied undergraduate universities in smart city <i>Lijun Xu*, Jianjun Hou, Zhe Chen & Jun Gao</i>	210
22.	Mode innovation of the “Belt and Road” supply chain finance under the background of digital technology <i>Yaqin Dou*, Shaobu Bai, Li Yao & Qian Sun</i>	218
23.	Opportunity in pandemic: Understand how customers look at your banner ads <i>Janjao Mongkolnavin*, Pimmanee Rattanawicha, Sawitree Boonpatcharanon, & Chaiyasut Jongtavornvitaya</i>	228
24.	Personalized music recommendation based on style type <i>Yixi Li, Mandie Liu, Fu He & Liangqiang Li*</i>	239
25.	Prediction markets: A systematic review and meta-analysis <i>Roberto Louis Forestal*, Peng Cheng Zhang & Shih-Ming Pi</i>	250
26.	Projecting the community pharmacy into home health care: An IS perspective <i>Alexandra Maria De Almeida Ângelo*, João Barata & Ana Paula Melo Santos</i>	265
27.	Research on consumers' buying behavior in the context of "Helping Farmers Live”: Based on the dual role of economic rationality and normative rationality <i>Xiaolin Li, Mengqian Guo* & Dunhu Huang</i>	275
28.	Research on credit mechanism of electronic honor certificate system based on blockchain <i>Ying Zhao, Jia Li, Liang Zhou* & Aobo Lyu</i>	283
29.	Research on customer classification and service quality evaluation of online education platform <i>Jinjing Li, Yongzhong Yang* & Baibokonov Doszhan</i>	292
30.	Research on design method of intelligent furniture <i>Jie Wang* & Chang Lu</i>	302
31.	Research on design of intelligent cleaning robot for solar panel <i>Shengzan Yan*, Ye Jian & Lijun Xu</i>	313

32.	Research on mode and risk prevention of agricultural supply chain finance based on e-commerce <i>Qiming Zheng, Mingxuan Zheng & Yaqin Dou*</i>	321
33.	Research on the bionic product design of smart home robots for the urban youth <i>Xin Liu*, Wen Zhang & Qiulu Zhou</i>	332
34.	Research on the operation of Changzhou distribution center of Huitong express in the peak period of online shopping <i>Fujian Ge, Li Yao* & Xing Gu</i>	340
35.	Research on the regional cooperative innovation in Guangdong-Hong Kong-Macau greater bay area <i>Haiyun Qiu, Jin'e Jiang, Wanying Li & Yichang Hao*</i>	354
36.	Research on upgrading and building of public technology service platform for SMES in Jiangsu province under the background of "Internet +" <i>Li Yao* & Fujian Ge</i>	365
37.	Research on users' perceived beliefs from the perspective of review components <i>Qiong Jia*, Huizhou Jiao & Yuxuan Li</i>	375
38.	Re-think insurance: A new perspective of InsureTech <i>Julian Yu* & Benjamin Yen</i>	386
39.	Role of social media in creating awareness during COVID-19 pandemic <i>Tahany Almotawa & Duaa Aljabri*</i>	398
40.	The impact of employment discrimination on job search performance <i>Xintong Liu, Qiong Jia* & Longhui Li</i>	406
41.	The influence of Pinduoduo group-buying mode on consumers' impulse buying <i>Jiali Cai, Xiaolin Li*, You Li & Sujuan Song</i>	414
42.	The role of ICT in sustainable development: The Ugandan narrative <i>Samuel Ekundayo*, Maryam Tabatabaee & Karthik Sridhar</i>	424
43.	User resistance behavior in the post-implementation stage of a hospital information system <i>Peilei Fu, Hongjiao Fu, Liang Zhou* & Ying Zhao</i>	435
44.	Website quality of listed companies: A comparison between SMES and large firms <i>Mathupayas Thongmak* & Winai Nadee</i>	447
45.	What factors influence customers' purchase intentions in travel-related social commerce? <i>Jin Guo, Shan Shan* & Yulei Li</i>	456

PART 2: Work-in-Progress Papers

46.	An integrated computer vision based OOH audience measurement system <i>Jialou Wang*, Honglei Li & Shan Shan</i>	468
47.	Citizens' adoption of digital technologies during COVID-19 <i>Thamer Alshammari*, Chris Messom & Yen Cheung</i>	474
48.	Constructing national identity education through online platform: A case study of discovery education for primary schools in UK <i>Erhui Shao & Honglei Li*</i>	478
49.	R&D investment that enhances it firm survival <i>Buraj Patrakosol</i>	483

50. Rural destination revitalization in Shennongjia forestry district: A tourism poverty alleviation perspective 489
*Junyang Lu, Aimin Deng & Penghao Ye**
51. Successful features of crowdfunding campaigns: An analysis of requests for Coronavirus food relief 496
Nan Zhao, Zhengqing Yuan, Jiajie Zou, Candy L. Chiu, Han-Chiang Ho & Somkiat Mansumittrchai*
52. The continuous use intention and antecedents of the novice player group in social network online games 501
*Wei-Hsi Hung & Kai-Ju Chuang**

PART 3: Abstracts

53. Lessons of COVID-19 pandemic on cross border e-commerce and suggestions 506
Tzushan Tseng

A Comparative Analysis between Airbnb and Hotel Industry: The Investigation from China

(Full Paper)

Xiong Zhang*, Beijing Jiao Tong University, China, xiongzhang@bjtu.edu.cn

Wenbo Liu, Carnegie Mellon University, wenbol2@andrew.cmu.edu

ABSTRACT

This paper constructs a comparative analysis to investigate the impact of sharing economy on the traditional hotel industry, using data collected from Airbnb and their hotel counterparts CTrip in ten major cities in China. Comparative static analysis and a multivariate regression model are used to draw the following conclusions: firstly, there exists a weakly negative impact of sharing accommodation rental on the traditional hotel industry. Airbnb's listing price and hotel price are weakly negatively associated. Moreover, the overall occupancy rate and rating of Airbnb listings do not significantly influence hotel price. Hotel price is mainly affected by hotel ratings and the average local income. The main findings offer managerial insights to managers in Airbnb and hotels.

Keywords: Sharing economy, Airbnb, hotel industry, quantitative analysis.

*Corresponding author

INTRODUCTION

Sharing economy is a new business model to share or to rent the right to use products or services to other individuals in a peer-to-peer fashion (Wikipedia, 2020). The emerging unicorn companies, e.g., Airbnb, Uber, and Mobike, in sharing economy have deeply involved into our daily lives and significantly changed people consumption behaviors. It is reported that the revenue of sharing economy will exceed US \$335 billion by 2025 (Rose, 2019). Given such emerging phenomenon, there are increasing discussions about the impacts of sharing economy on traditional economy.

By gathering a large number of unused resources, products or services provided in the online sharing platforms could compete directly to traditional enterprises offering similar products and services. For instance, Airbnb, the sharing accommodations service provider, could operate at a much lower cost since an Airbnb listing can be rent repeatedly anytime the owner wants, which grants considerable flexibility in the supply side of room offering. On the other hand, the supply increase from hotels may lead to a high vacancy rate during the off-season, leading to unacceptable losses. Besides, the housing vacancy rate has been over 25% in China (Blazyte, 2018) in the hotel market. Thus, the sharing accommodation holds a competitive advantage over the traditional hotel industry. Traditional housing rental suppliers will inevitably be impacted by entries of newcomers like Airbnb. Similarly, in mobility, Uber and Didi have caused a catastrophic blow on the traditional taxi market (Nie, 2017).

Yet discussions regarding to the impacts of sharing economy on traditional economy have not lead to consistency in existing literature (Choi *et al.*, 2015; Dogru, Mody, & Suess, 2019). On one hand, Dogru, Mody, and Suess (2019) found that sharing accommodation rental would compete with hotels. On the other hand, Choi *et al.* (2015) found there does not exist significant impacts between Airbnb and local hotels. Even in the hotel market, prior study has found that the impact of room sharing on the traditional hotel industry is different among different countries and different cities (Blal, Singal, & Templin, 2018; Guttentag & Smith, 2017; Xie & Kwok, 2017).

Given such confusion, this study aims to better understand the impact of sharing economy on the traditional economy in accommodation industry, at least adding evidence or empirical support from China perspective. More specifically, we investigate the accommodation rental sector of the tourism and hospitality industry and try to examine the impact of Airbnb on the hotel industry in major cities in China. Given the heterogeneity among different locations, we collect data from Airbnb and hotel listings' prices, reviews, addresses in multiple cities and regions at the same time. We first compare data among different regions for static analysis and then run regression analysis to examine the impact of room sharing on traditional hotels. Based on these analyses, this article makes corresponding suggestions for decision-makers of both Airbnb and the traditional hotel industry. Our finding could help to better understand how sharing economy like Airbnb would influence traditional hotel industry in China.

LITERATURE REVIEW

As a new emerging business phenomenon, sharing economy has entered into various industries, such as Airbnb in accommodation, Uber and Didi in mobility and Mobike in sharing bikes. As an echo of such business trend in academia, researchers have tried to examine the effect of sharing economy on traditional industries.

The effect of sharing economy has been investigated from perspectives of low-end vs high-end. Dogru, Mody, and Suess (2019) and Zervas, Proserpio, and Byers (2017) have shown the effects of sharing accommodation rental on hotels are twofold: in the low-end accommodation market, Airbnb would compete with hotels, while in the high-end accommodation market, hotels are less affected by the sharing economy.

Other researchers have studied the sharing economy's impact on traditional industries in different locations. In accommodation industry, Airbnb's impact on hotels is different across different countries due to different economic environments and market structures in each country. Besides, supply, classification, and price of hotel markets in different countries are also very different. In US, Airbnb is identified as a significant disturbance factor for the local hotel market and the revenue of hotels has been affected by Airbnb (Xie & Kwok, 2017). It is found that Airbnb could serve as an imperfect alternative for hotels and constitutes a direct competitive relationship with hotels (Blal *et al.*, 2018; Guttentag & Smith, 2017). On the other hand, researchers find that Airbnb has not negatively affected the local hotel market in South Korea (Choi *et al.*, 2015) and Norway (Strømme-Bakhtiar & Vinogradov, 2019). The relationship between Airbnb and local hotels is complementary rather than competitive because they have different target customer groups as well as pricing strategies. These studies believe that the increase in Airbnb listings will help improve the overall performance of the hotel market due to the elasticity of the Airbnb supply.

Airbnb has entered China for years. Both of the numbers of Airbnb's listings and the number of orders are growing at a fairly rapid rate. It has already become an important force in the Chinese accommodation market. Thus, this research quantitatively analyzes Airbnb's impacts on the Chinese hotel market. This paper aims at comparing and analyzing the hotel and accommodation rental in China, in order to figure out the relationship between the sharing economy and the hotel industry.

DATA COLLECTION AND DATA PROCESSING

The sample in this study is from ten major cities in China: namely Beijing, Shanghai, Guangzhou, Shenzhen, Tianjin, Nanjing, Wuhan, Chengdu, Shenyang and Xiamen. The first four cities are the well-known tier 1 cities in China. The following five cities are the regional representative cities in China. The last city is one of the popular tourism cities in China. Furthermore, among the ten cities, one is in the Northeast China, two are in the North China, two are in the East China, one is in the Southeast China, two are in the South China, one is in the Central China, and one is in the Southwest China. We choose these ten cities for two reasons: (1) these are the top performing cities in China in terms of hotel room supply and Airbnb supply; (2) these ten cities are located in various regions in China.

For data collection, we design and implement a web crawler in Python. The data in this study is collected from two sources: (1) the Airbnb listing data from Airbnb China's official website (www.airbnb.cn), and (2) the hotel listing data of the searched results in Ctrip (www.Trip.com) under the hotel category. As the initial investigation, we plan to conduct the static comparative analysis, thus, all the data is collected from Mar 19, 2019 to Mar 20, 2019. This could avoid the effects from weekends and holidays. For instance, on vacations like traditional Chinese New Year or National Day, people are more likely to have family trips thus would spend more money on room bookings. As a result, on holiday seasons, room demand increases significantly and customers tend to be less sensitive in room prices, and thus the listing prices would increase significantly as well. Data would be collected in a longer period to include the weekend and holiday effects in future research. Besides, all data are crawled from both websites simultaneously to avoid any inconsistency from time effect.

Based on preliminary observations in Airbnb and Ctrip, and for the purpose of facilitating static comparative analysis between Airbnb and hotel listings in different regions, we crawl the following listing metadata from Airbnb: price, geographic location (both longitude and latitude), number of reviews, and star ratings. To avoid the effects of holidays and weekends, this paper queries the average price of Airbnb and hotel listings from March 24, 2019 to March 30, 2019. This average price within a week could approximately serve as the overall price level of the listing during data collection. The effects of holidays will be explored in the future.

Currently we have not got the three major performance indexes in the hotel industry: daily room average income (Revenue of Per the Available Room, RevPar), the daily average price (Average Daily Rate, ADR) and occupancy (Occupancy, OCC). Thus, this article adopts the average price (Hotel Listing Price) within a week as the measurement for daily average price. This is also for the purpose to compare with Airbnb, where the bookings data is not available neither. In the future research, we plan to extend the current research by getting RevPar, ADR and OCC to measure hotel performance.

After crawling, all records with missing values and duplicate values are removed. Rooms without reviews in Airbnb are usually the ones have not been booked previously. We then remove outliers by observing the scatter plots of data separately. We also remove data including prices not consistent with common sense.

Originally, we crawled 46477 records of hotel data from Ctrip and 2055 records from Airbnb for ten cities in the specific time period. The data size from Airbnb is significantly smaller than that from Ctrip is because usually only around 200 listings are shown in Airbnb for a given region (sometimes even less depending on the region's popularities). We could crawl more data from cities like Beijing, Shanghai, Guangzhou, Shenzhen, Chengdu, Shenyang but less data from cities like Tianjin, Nanjing, Xiamen, which is consistent with our common sense, since the former are cities with stronger economic performance and higher accommodation needs. In this study, our dataset including 46477 records from Ctrip and 2055 records from Airbnb, with attributes like prices, locations, number of reviews, star rating.

In this preliminary study, we would like to statically compare the impact of Airbnb on Ctrip, thus, we need to identify rooms in Airbnb and hotels in Ctrip in the same region. Due to the strict privacy policy in Airbnb, the location of all listings on its website is intentionally obscured. The exact location of listings cannot be obtained before booking. According to the fuzzy addresses of Airbnb listings, we could derive the geographic location (both latitude and longitude) of listings. The distance (in kilometers) between each listing and the geographic center of the city could be calculated to measure the listing location. Finally, we establish a dataset with 187 region-level records for ten cities.

DATA ANALYSIS

In this section, we would first present the descriptive analysis for our data collection, and then describe the dependent variable, independent variables and regression results.

Preliminary Analysis

	Average Price/RMB	Average Distance/KM	Average Rating
Airbnb	233.839337	6.12115102	4.8968
Hotel	226.269921	8.26378175	4.2726

The preliminary analysis shows generally the average price in Airbnb is higher than that in Ctrip, and rooms in Airbnb are closer to the geographical center of the city. This pattern is consistent in all 10 different major cities. Furthermore, quality (ratings from consumers) of rooms in Airbnb is generally higher than that in traditional hotels.

Although luxury hotels are much more expensive than rooms in Airbnb in most cities, the median hotel price in each city is significantly lower than the average price, leading to that most hotels are budget-oriented. On the other hand, Airbnb is family, vacation, and leisure-oriented, offers a large number of large-sized, well-equipped and comfortable homes. Thus, the price is relatively higher than that of hotels.

Rooms listed in Airbnb are generally closer to the city center compared to hotels. This maybe because most budget hotels locate far away from downtown. In contrast, tourism and leisure-oriented Airbnb listings are usually well located for convenience, and they are often closer to downtown. Besides, another explanation may be that the collected Airbnb listing are high-quality listings selected by Airbnb, so they are generally well located. Furthermore, the average rating is higher in Airbnb than that in Ctrip.

Explanatory Variables, Dependent Variables and Control Variables

This research chooses the average hotel price (HPrice) as an indicator in the hotel market. There exist thousands of hotels in Ctrip and rooms in Airbnb, leading to an almost perfectly competitive market. Thus, price could serve as the indicator whether Airbnb's supply will positively or negatively impact the hotels' prices.

We first average the price, rating, and occupancy for all Airbnb listings with the same address. Then, to match the hotel located in the same region, we choose to map hotels to the nearest Airbnb listing in fuzzy geographical location. That is, every hotel is matched to the nearest Airbnb listing. Overall, this article obtained a sample of 187 addresses from 10 cities across the country and recalculated the distance from each listing location in each city to downtown of the city respectively. Since the actual bookings is not displayed in Airbnb website, this paper chooses the count of reviews in Airbnb website as the proxy to measure listing occupancy. Similar approach has been used in existing literature (Zervas, Proserpio, & Byers, 2017).

China is a vast country and hug difference exists among different cities, especially in economy performance. We consider the heterogeneity in market environment among cities by introducing the following control variables: regional average house

price/yuan (district level), annual average income/yuan (city level), population / million (city level). Average house price in certain regions is closely related to prices of room offerings in the supply side in this region. On the other hand, average income and population are closely related to the demand side in hotel industry. This research uses the average house price in April 2019 from <http://www.cityhouse.cn/city.html>, and population and the average income reported in the end of 2017 from National Bureau of Statistics of China (<http://data.stats.gov.cn>).

Table 1 describes all variables.

Table 1: Variable Description

Variable	Description
HPrice	Average hotel price in RMB
APrice	Average price of Airbnb in RMB
ARating	Airbnb average score (out of 5)
AReview	Average number of Airbnb reviews
Distance	Distance from the geographic center of the region in kilometer
HRating	Average hotel rating (out of 5)
HousePrice	Average house price in district, in RMB
Income	Average urban income, in RMB
Population	Urban population, in 10 thousand

Table 2 shows descriptive analysis in the dataset.

Table 2: Descriptive Analysis

	HPrice	APrice	ARating	AReview	Distance	HRating	HousePrice	Income	Population
count	187	187	187	187	187	187	187	187	187
mean	226.27	233.84	4.90	30.27	6.12	4.27	46039.56	97883.73	926.04
std	67.62	66.54	0.13	24.24	5.28	0.10	24980.11	20921.12	406.82
min	135.09	67.00	4.00	4.00	0.34	4.08	6769.00	74181.00	231.03
25%	179.83	192.37	4.84	15.08	2.30	4.20	22411.00	79292.00	680.67
50%	205.13	225.81	4.93	25.35	5.00	4.26	46745.00	98612.00	897.87
75%	253.41	274.12	5.00	39.04	8.37	4.34	55317.00	101502.00	1359.20
max	533.25	458.00	5.00	190.00	43.71	4.52	132971.00	134994.00	1455.13

The correlation analysis show there exists a high correlation among variables, leading to the issue of multiple collinearities. More specifically, there exists a strong linear relationship among hotel prices, house price and income ($|r| > 0.7$). There is a moderate linear relationship among hotel prices, hotel ratings and population ($|r| > 0.3$). A weak linear relationship exists between hotel price and geographical location (distance) ($0.1 < |r| < 0.3$).

Tables 3 shows the correlation analysis of the data sample. The titles in the table represent:

Table 3: Correlation Analysis

	HPrice	APrice	ARating	AReview	Distance	HRating	HousePrice	Income	Population
HPrice	1.000								
APrice	-0.050	1.000							
ARating	0.047	0.151	1.000						
AReview	0.070	0.098	-0.080	1.000					
Distance	0.160	-0.019	0.030	-0.002	1.000				
HRating	-0.316	0.311	0.041	0.071	-0.122	1.000			
HousePrice	0.753	-0.022	0.110	0.044	-0.058	-0.265	1.000		
Income	0.844	0.106	0.034	0.081	0.153	-0.485	0.707	1.000	
Population	0.369	-0.157	-0.135	0.083	-0.004	-0.201	0.033	0.509	1.000

Regression Analysis

We build a logarithmic linear regression model as follows:

$$\ln HPrice_i = c + \alpha \ln APrice_i + \beta \ln ARating_i + \lambda \ln AReview_i + \delta \ln Distance_i + \nu \ln HRating_i + \eta \ln HousePrice_i + \theta \ln Income_i + \epsilon \ln Population_i \quad (1)$$

where $HPrice_i$ is the average hotel price in region i , $APrice_i$ is the average price in Airbnb in region i , $ARating_i$ indicates the average rating in Airbnb in region i , $AReview_i$ is Airbnb listing's the average count of reviews in the region i , $Distance_i$ is the distance from region i to the geographic center of the city (in kilometer), $HRating_i$ indicates the average hotel rating in region i , $HousePrice_i$ is the average house price (in RMB) of region i , $Income_i$ indicates the average income (in RMB) in the city where region i belongs to, and $Population_i$ indicates the population in the city where region i belongs to (in 10,000).

To downplay the impact caused by multicollinearity among variables, we use the stepwise regression to isolate and filter out insignificant explanatory variables. During analysis, this paper adopts the backward stepwise regression analysis. The explanatory variables Airbnb rating ($p = 0.7863$), Airbnb average number of Reviews (used to represent the occupancy of the listing) ($p = 0.6429$), and population ($p = 0.3410$) were eliminated.

The results of regression analysis are reported in Table 4, Table 5 and Table 6 as follows:

Table 4: Coefficients of the Regression Model

Average Hotel Prices			
	coefficient	standard error	t test p-value
Intercept (c)	-9.735243915***	1.124582996	2.61304×10^{-15}
APrice (α)	-0.179328941***	0.030450878	1.85157×10^{-8}
Distance (δ)	0.03985593***	0.010336551	0.000160135
HRating (ν)	2.478374709***	0.456782387	1.83295×10^{-7}
HousePrice (η)	0.155346206***	0.020309919	1.15778×10^{-12}
Income (θ)	0.940598849***	0.069731228	3.74795×10^{-29}

Note: significance level: *** 1%, ** 5%

Table 5: Regression Statistics

Regression Statistics	
Multiple R	0.906116409
R Square	0.821046947
Adjusted R Square	0.816103493
Standard Error	0.116478604
Observations	187

Table 6: Analysis of Variance

ANOVA					
	DF	SS	MS	F	Significance F
Regression	5	11.26677875	2.25335575	166.0876918	1.16483×10^{-65}
Residual	181	2.455674989	0.013567265		

Note: DF stands for degrees of freedom, SS stands for sum of squares, MS stands for mean squared, R stands for regression, and Residual stands for residual error.

The adjusted R2 is 0.816103493 (see Table 5). According to regression results, the presence of Airbnb has significant impacts on hotel prices in the same region. This pattern is statistically significant. The analysis of variance (see Table 6) shows the F value is 166.088, and the p-value of the F test is 1.164483×10^{-65} , indicating the high confidence of this regression results.

According to the regression results, the regression model could be presented as:

$$\ln HPrice_i = -9.7352 - 0.1793 \times \ln APrice_i + 0.0398 \times \ln Distance_i + 2.4784 \times \ln HRating_i + 0.1553 \times \ln HousePrice_i + 0.9406 \times \ln Income_i \quad (2)$$

This model shows that, for hotel prices, there exist significant positive effects of listing distance, hotel room rating, house price in certain region and consumers' income on hotel room price. On the other hand, there exists significant negative effect of room price in Airbnb on in hotel. According to this model, the average hotel price would decrease if Airbnb's price in the same region increases, leading to a negative impact of sharing apartments on traditional hotels. Thus, in the accommodation rental sector, the sharing room may weakly negatively relate to prices of traditional hotels.

Model Extension

Some market factors would influence the hotel room price. Thus, to test the robustness of our model, we consider following control variables: Total Retail Sales of Consumer Goods (TRSCG) and Gross Domestic Product (GDP). The total retail sales of consumer goods refers to the amount of physical goods sold by enterprises, through transactions to individuals and social groups for non-production and non-business use, as well as the amount of income derived from the provision of catering services. This indicator only include commodities sold to individuals for daily consumption, which is a perfect measure of the region's consumption level. It can represent the willingness that people would like to spend their money. GDP, on the other hand, is an indicator of the region's overall production outcome. GDP reflects a region's overall economic status. It may represent the consumption intensity of citizens in certain regions. Since TRSCG and GDP are a reflection of region level consumption and overall economic situation, they are closely related to hotel prices.

The extension model is presented as follows:

$$\ln HPrice_i = c + \alpha \ln APrice_i + \beta \ln Distance_i + \lambda \ln HRating_i + \delta \ln HousePrice_i + \nu \ln Income_i + \eta \ln Retail_i + \theta \ln GDP_i \quad (3)$$

where $HPrice_i$ is the average hotel price in region i , $APrice_i$ is the average price in Airbnb in region i , $Distance_i$ is the distance from region i to the geographic center of the city (in kilometer), $HRating_i$ indicates the average hotel rating in region i , $HousePrice_i$ is the average house price (in RMB) of region i , $Income_i$ indicates the average income (in RMB) in the city where region i belongs to, $Retail_i$ indicates the total annual retail sales (in 100 million RMB) in the city region i belongs to, and GDP_i indicates the annual domestic production in the city region i belongs to (in 100 million RMB).

Similarly, we adopt stepwise regression approach to reduce the effect of multicollinearity. Insignificant explanatory variables are removed using backward stepwise regression analysis.

Regression results of the extended model are presented in Table 7, Table 8 and Table 9:

Table 7: Coefficients of Model Extension

Average Hotel Prices			
	coefficient	standard error	t test p-value
Intercept (c)	-10.49846363***	1.223387458	4.39645×10^{-15}
APrice (α)	-0.246433167***	0.037530348	5.40718×10^{-10}
Distance (β)	0.048973906***	0.010331739	4.34069×10^{-6}
HRating (λ)	2.553221128***	0.444594336	3.92402×10^{-8}
HousePrice (δ)	0.196130744***	0.032823518	1.21271×10^{-8}
Income (ν)	1.052679315***	0.1421674	4.97358×10^{-12}
TRSCG (η)	0.174051323***	0.055270403	0.001919472
GDP (θ)	-0.231554991***	0.048236919	3.32961×10^{-6}

Note: significance level: *** 1%, ** 5%

Table 8: Regression Statistics of Model Extension

Regression Statistics	
Multiple R	0.917466312
R Square	0.841744433

Adjusted R Square	0.835555668
Standard Error	0.110146035
Observations	187

Table 9: Analysis of Variance in Model Extension

ANOVA					
	DF	SS	MS	F	Significance F
Regression	7	11.55079904	1.650114149	136.0116935	3.44203×10^{-68}
Residual	179	2.171654694	0.012132149		

Note: DF stands for degrees of freedom, SS stands for sum of squares, MS stands for mean squared, Regression stands for regression, and Residual stands for residual error.

The adjusted R2 is 0.84 (see Table 8). According to regression results, the influence of Airbnb on hotel prices in the same region is statistically significant. The analysis of variance (see Table 9) shows the F value is 136.0, and the p-value of the F test is close to 0, indicating the high confidence of our model.

According to regression results, the extended regression model could be presented as:

$$\ln HPrice_i = -10.49846363 - 0.246433167 \ln APrice_i + 0.048973906 \ln Distance_i + 2.553221128 \ln HRating_i + 0.196130744 \ln HousePrice_i + 1.052679315 \ln Income_i + 0.174051323 \ln Retail_i - 0.231554991 \ln GDP_i \quad (4)$$

According to results of the extended model, it can be found that the impacts of TRSCG and GDP on hotel price are statistically significant. The coefficients of the original explanatory variables and control variables have not changed significantly. Therefore, Airbnb listings' price has a weak negative correlation with hotel prices. The main factors affecting hotel prices are hotel ratings and the region's average income.

Through this initial preliminary static comparative analysis, we find there might exist negative impact coming from Airbnb room offering on traditional hotel industry at least in Chinese market. This finding could help to add empirical support about the impact of room sharing on traditional accommodation industry and help to better understand the impact from sharing economy.

CONCLUSIONS AND DISCUSSIONS

With the rapid development of Internet Technology, business models and processes are significantly changing over time. With the support of IT infrastructure, the rights of using products and service could be rent to other individuals, this will inevitably have impacts on traditional industries. Increasing research attention has been given to the impact of such sharing economy on traditional economy. However, the existing literature has not drawn consistent conclusion, thus more empirical supports are urgently needed.

From the point of view in Chinese market, this study would like to empirically investigate this issue in hotel industry. More specifically, this research could fill the gaps in the current research on the impact of the sharing economy on the Chinese hotel industry and the relationship between them. Based on these analyses, this article could also make corresponding recommendations to decision makers in the sharing economy and the traditional hotel industry. We conduct a static comparative analysis and a regression analysis to examine the sharing economy's impacts on local hotels according to samples in ten major cities in China. These ten cities are representative since 4 tier-1 cities, 5 regional center cities and one truisim city are included. We crawl data from two sources: Airbnb and Ctrip. On the basis of raw data, we could establish a dataset including 187 region level records through location matching.

We find prices in Airbnb are negatively related to prices of traditional hotels. This finding is consistent and in high confidence when taking market level and national level factors into consideration. Thus, Airbnb might weakly negatively relate to Ctrip. The main finding in initial analysis is promising. This study contributes to existing literature on sharing economy by providing potential empirical evidence about the impact of sharing economy on traditional economy in accommodation rental sector in tourism and hospitality industry.

The reason for the weak negative relationship between Airbnb and hotels in Ctrip might be that Airbnb and Ctrip would compete for consumers in some levels, but not all of them. Airbnb and Ctrip generally target to different groups of consumers. Sharing economy like Airbnb mainly targets at family travel and leisure trips. Airbnb generally provides a suitable exchange,

warm living environment, at a relatively reasonable price. On the other hand, the traditional hotel industry are serving a broader range of customers. The price range of hotels is much larger than that of Airbnb due to the existence of both luxury hotels and budget hostels to meet the needs of different customers.

This work is not without limitations. First, we only collect the top 300 high-quality listings in Airbnb because only the top 300 listings in a city are shown on its websites. Second, the accurate location cannot be crawled because of the strict privacy policies in Airbnb. To address this issue, we match the hotel's geographic location with Airbnb's fuzzy geographic location, leading to a smaller sample size. Finally, other macroeconomic factors, e.g., market issues and policies, might be considered. But we leave these issues for future research.

ACKNOWLEDGMENT

This work was partially supported by grants from National Natural Science Foundation of China (Grant No. 71801014). Xiong Zhang (xiongzhang@bjtu.edu.cn) is the corresponding author.

REFERENCES

- [1] Blal, I., Singal, M., & Templin, J. (2018). Airbnb's effect on hotel sales growth. *International Journal of Hospitality Management*, 73, 85-92. <https://doi.org/10.1016/j.ijhm.2018.02.006>
- [2] Blazyte, A. (2018). More than 50 million empty apartments in China. Statista. Retrieved from <https://www.statista.com/chart/16137/home-vacancy-rate/> (accessed 1 October 2020).
- [3] Choi, K. H., Jung, J., Ryu, S. Y., Kim, S. D., & Yoon, S. M. (2015). The relationship between Airbnb and the hotel revenue: in the case of Korea. *Indian Journal of Science and Technology*, 8(26), 1-8. <https://doi.org/10.17485/ijst/2015/v8i26/81013>
- [4] Dogru, T., Mody, M., & Suess, C. (2019). Adding evidence to the debate: Quantifying Airbnb's disruptive impact on ten key hotel markets. *Tourism Management*, 72, 27-38. <https://doi.org/10.1016/j.tourman.2018.11.008>
- Guttentag, D. A., & Smith, S. L. (2017). Assessing Airbnb as a disruptive innovation relative to hotels: Substitution and comparative performance expectations. *International Journal of Hospitality Management*, 64, 1-10. <https://doi.org/10.1016/j.ijhm.2017.02.003>
- [5] Nie, Y. M. (2017). How can the taxi industry survive the tide of ridesourcing? Evidence from Shenzhen, China. *Transportation Research Part C: Emerging Technologies*, 79, 242-256. <https://doi.org/10.1016/j.trc.2017.03.017>
- [6] Rose, D. (2019). Outlook for the Sharing Economy 2019. More Than Accountants. Retrieved from <https://www.morethanaccountants.co.uk/outlook-sharing-economy-2019/> (accessed 1 October 2020).
- [7] Strømmen-Bakhtiar, A., & Vinogradov, E. (2019). The effects of Airbnb on hotels in Norway. *Society and Economy*, 41(1), 87-105. <https://doi.org/10.1556/204.2018.001>
- [8] Wikipedia. (2020). Sharing economy. Wikipedia. Retrieved from https://de.wikipedia.org/wiki/Sharing_Economy (accessed 1 October 2020).
- [9] Xie, K. L., & Kwok, L. (2017). The effects of Airbnb's price positioning on hotel performance. *International Journal of Hospitality Management*, 67, 174-184. <https://doi.org/10.1016/j.ijhm.2017.08.011>
- [10] Zervas, G., Proserpio, D., & Byers, J. W. (2017). The rise of the sharing economy: Estimating the impact of Airbnb on the hotel industry. *Journal of marketing research*, 54(5), 687-705. <https://doi.org/10.1509/jmr.15.0204>

A Two-Stage Real-time Prediction Method for Multiplayer Shooting E-Sports

(Full Paper)

Jiixin Liu, Sichuan University, China, 1007297545@qq.com

Jiixin Huang, Sichuan University, China, 1435958090@qq.com

Ruyun Chen, Sichuan University, China, 562789829@qq.com

Tianchang Liu, Sichuan University, China, 190758398@qq.com

Liang Zhou*, Sichuan University, China, zhouliang_bnu@163.com

ABSTRACT

E-sports is an industry with a huge base and the number of people who pay attention to it continues to rise. The research results of E-sports prediction play an important role in many aspects. In the past game prediction algorithms, there are mainly three kinds: neural network algorithm, AdaBoost algorithm based on Naïve Bayesian (NB) classifier and decision tree algorithm. These three algorithms have their own advantages and disadvantages, but they cannot predict the match ranking in real time. Therefore, we propose a real-time prediction algorithm based on random forest model. This method is divided into two stages. In the first stage, the weights are trained to obtain the optimal model for the second stage. In the second stage, each influencing factor in the data set is corresponded to and transformed with the data items in the competition log. The accuracy of the prediction results and its change trend with time are observed. Finally, the model is evaluated. The results show that the accuracy of real-time prediction reaches 92.29%, which makes up for the shortage of real-time in traditional prediction algorithm.

Keywords: real-time prediction; machine learning; two-stage algorithm; E-sports.

*Corresponding author

INTRODUCTION

The prediction of E-sports competition has an important impact on the development of e-sports industry (Keiper *et al.*, 2017) and the optimization of game content (Breiman, 2001). There are some related prediction algorithms about the existing popular games and popular E-sports projects (Bosc *et al.*, 2014). At present, there are three kinds of game prediction algorithms: neural network algorithm, AdaBoost algorithm based on Naive Bayesian (NB) classifier and decision tree algorithm. These three algorithms have their own advantages and disadvantages. The neural network model is suitable for the scene with large amount of data and the intrinsic relationship between parameters. Its advantage is that the parallel distributed processing ability is strong, it can extract data features and approximate complex nonlinear relations. The disadvantage is that the learning time is too long when a large number of parameters are needed. The learning process cannot be observed and the output results are difficult to explain. AdaBoost algorithm can take different classification algorithms as weak classifiers, which makes good use of weak classifiers to cascade. AdaBoost has high accuracy. Compared with bagging algorithm and random forest algorithm, AdaBoost fully considers the weight of each classifier. However, the problem is that the number of weak classifiers is not easy to set, so cross validation is needed to determine. And the data imbalance will lead to the decline of classification accuracy. The advantage of the decision tree algorithm is that it is convenient for us to intuitionistic decision rules, at the same time, it can deal with the nonlinear characteristics and consider the interaction between variables. The disadvantage is that it is easy to over fit and it is very difficult to deal with missing data. However, the rankings predicted by these algorithms are the final rankings at the end of the game, and they do not predict the behavior of the game in real time. The frequency of data monitoring required by real-time prediction is more difficult. Although the prediction of the results is more accurate, the requirements of the algorithm are also higher. The prediction needs to obtain the player's status at each time, including the equipment the player obtains, the player's behavior characteristics and so on. At the same time, there are some unpredictable and nonstandard factors for the results, such as the influence of random refresh mechanism on players' psychology, the influence of players' personal level, etc., which will cause deviation to the results. But the real-time prediction can dynamically display the competition situation. The real-time prediction takes into account the changes of the importance of each index in different stages of the competition with the development of the competition process (Ziegler & König, 2014). However, the current E-sports ranking prediction algorithm has not considered the real-time prediction problem, so this paper focuses on the real-time prediction of E-sports competition.

Before the real-time prediction, the real-time prediction algorithm must first get a weight model of the factors that influence the game results, and then put the data into the prediction according to the new method on the basis of this model. Therefore, the research stage is divided into two parts. In the first stage, the problem to be studied is to predict the players' final ranking according to the overall performance of the players in the game, and calculate the influence weight of the main factors in the game for the players to win. The second stage is to predict the players' game rankings in real time, that is, according to the players' performance in a short period of time, track the game rankings in real time and predict their final rankings. In real-time prediction, data acquisition and cleaning are also particularly important. The experimental data should ensure perfect

characteristics, uniform format, and enough data to support the accuracy of the results, excluding the influence of accidental events. Therefore, the difficulty of this study is dealing with the large amount of data in the original data set, and the calculation takes a long time, which has certain requirements for the performance of the algorithm. For the case of large number of features, it is necessary to weight different features according to their importance, or generate additional features through analysis. In the problem of model selection, ensemble learning is needed to improve the accuracy of the algorithm. The research on real-time prediction not only improves the theory of prediction algorithm in machine learning, but also promotes the development of e-sports industry. In recent years, with the rapid development of the electronic game industry (Rahman *et al.*, 2020), the e-sports industry is also developing in the direction of professional sports (Kinkade *et al.*, 2015). Many games have been held online and offline all over the world, and many games have been listed as official events in the Asian Games. Data analysis plays an extremely important role. The official team and professional team of each game need professional personnel to collect, process and analyze the game data, so as to adjust and optimize the game content or help the team win the game (Pluss *et al.*, 2019). Therefore, this paper aims to predict the player ranking in the game from a new perspective, so as to help the relevant personnel in the e-sports industry.

Firstly, this paper summarizes the main methods and existing problems of game prediction algorithm. Then, the design of our research (real-time prediction algorithm based on random forest) is described from four aspects: research ideas, experimental preparation, experimental process and experimental results. Finally, we evaluate our model algorithm from the aspects of accuracy, implementation ranking and prediction fluctuation, discuss the innovation points and shortcomings of this experiment, and put forward the areas that can be improved, and look forward to the future research.

LITERATURE REVIEW

At present, there are three kinds of game prediction algorithms: neural network algorithm, AdaBoost algorithm based on NB classifier and decision tree algorithm.

Neural Network Algorithm

At present, there are many directions of improvement about neural network prediction algorithm. Because sports competition and E-sports have a lot of similarities in competitive rules, this paper also refers to the prediction algorithm of team events in sports competition. Using the deep neural networks (DNNS) and artificial neural networks (ANN), MD. Ashiqur Rahman (Xiong *et al.*, 2014) established an effective framework to predict the results of football matches. The data set is used for ranking, team performance, results of all previous international football matches, etc. ANN and DNN are used to mine and process the motion data, and the predicted values are generated. The data set is divided into training, verification and testing. Using the proposed DNN structure, the corresponding model performs well in predicting the 2018 World Cup. The prediction accuracy of the model is 63.3%. From the perspective of prediction accuracy, it has reached the pass line, but due to the problems of data set selection and team information acquisition channel, the prediction accuracy is limited to a certain extent. This accuracy can be improved with appropriate data sets and more accurate team information.

AdaBoost Based on NB Classifier

Pulung Nurtantio Andono, Nanang Budi Kurniawan, Catur Supriyanto (Pereira *et al.*, 2016) used naive Bayes (NB) as classifier to predict the winning team in data mining algorithm. However, NB has some disadvantages such as data imbalance, so this study proposes some methods to implement AdaBoost based on NB, which are discretization and Gaussian distribution kernel function. Both are used to handle numeric properties. The experimental results show that the prediction accuracy of win with AdaBoost plus Gaussian distribution kernel can reach 80%. However, the training of AdaBoost algorithm is time-consuming, and the best segmentation point of current classifier needs to be re selected each time. It is time-consuming and laborious to train the model for many times to improve the prediction accuracy.

Decision Tree Algorithm

Firstly, the decision tree algorithm processes the data, generates readable rules and decision tree by inductive algorithm, and then analyzes the new data by using decision. As for the PUBG game, Yonghan Qiu uses classical machine learning algorithms such as linear regression and decision tree to analyze how different factors affect the winning rate of the game, and establishes a decision tree prediction model to predict the level of players. First of all, the author carries on the correlation analysis, obtains the data attribute which has the high correlation with the player rank. Then, due to the different types of players' data have some differences, these data reflect the level of players' game. According to the ranking score of each player, players are divided into four categories. In this paper, the decision tree is constructed based on the information gain value. By calculating the information entropy difference of different data sets to select the node to be split, the decision tree prediction model is successfully constructed and predicted. This is consistent with our research topic, but the author predicted the final ranking of players in the game, and did not track and predict players' behavior in real time.

RESEARCH METHOD

The research problem of this paper is the prediction of the electronic sports game - PUBG. The reason why we take PUBG as an example is that as a tactical competitive shooting sandbox game, PUBG has become popular all over the world. There are millions of active players every month, so we have a huge data base to support our experiments. At the same time, the research results are of great significance to many players and E-sports related personnel. The specific prediction direction is to predict the players' ranking in a game under the conditions of given equipment and landing point. We study the problem of regression,

y value is the prediction of the ranking. The first place is 1, the last one is 0, ranking as percentile. Because the actual competition contains too many factors, so our research is divided into two stages. In the first stage, the problem to be studied is to predict the player's final chicken eating ranking according to the player's overall performance in the game. At the same time, the weight of the main factors included in the game, such as the number of kills, the number of treatments, and the moving distance, is calculated. The second stage is the real-time prediction of players' chicken eating ranking. According to the players' performance in a short period of time, we can track the match rankings in real time and predict their final chicken eating ranking.

Data Sources

The data of stage 1 is from the real competition data provided by the open data set of Kaggle. The data set contains more than 65000 anonymous player data of games. The format of the training set data is that each row contains a player's post game statistical data, which is listed as the characteristic value of the data, with 29 data items. The data set includes all types of games: single row, double row, four row, but each game does not necessarily have 100 people, each team has up to 4 members. In the experiment, we will randomly scramble the data set and divide it into training set and test set according to the proportion of 70% and 30%. The method is to use the train in the sklearn Library of Python_ test_ Split() function. The data of stage 2 is from the JSON data of PUBG official API through crawler. First, determine the source platform and date of the game to obtain the match ID within 24 hours, then use the ID to obtain the match data of each game. Finally, the log JSON is obtained from the telemetry URL contained in the match data, which is the data set needed in stage 2. This data set has comprehensive features. There are 44 types of logs in a single game, the highest JSON file is 32MB, and the total number of 561 games is more than 8GB.

Assumptions

The main background and rules of PUBG are: in each competition, 100 players fly and are sent to different places on an island. Players are constantly shrinking and moving inside the "poison circle" while searching for materials, weapons and large escape with other players until the last person or team survives. In this game, PUBG has four maps: green land, desert, rain forest and snow. With different maps, the proficiency level of each team is different, and the ranking may be different. At the same time, there is an airdrop mechanism in the PUBG, and the team that grabs the airdrop has an absolute advantage in terms of materials due to its AWM, Groza and other air drop guns and three-level equipment. Another factor that needs to be considered is that the security zone will be refreshed randomly in the PUBG. The teams in the security zone have a natural advantage and can attack the teams entering the circle by blocking bridges or guarding the circle. Therefore, when forecasting, we should also consider whether we need to consider the factor of security zone refresh. Therefore, according to the above factors, the ranking prediction algorithm used in this paper is based on the following four prerequisites:

- 1) There are many data features generated in the game, but not all of them are related to the player's ranking. It is necessary to screen out some features that are not related to the prediction results or related but have repetition. After calculating the correlation, those less than 0.09 will be deleted and the features with greater relevance will be retained.
- 2) Since the data set of Kaggle does not include the data of weather, map type, player coordinates, poison ring coordinates, bombing area coordinates and weapon equipment types, the influence of these factors is not considered temporarily.
- 3) Without considering the influence of unpredictable factors such as player's personal factors, the result of game prediction is only related to the characteristics we set.
- 4) Players do uniform movement throughout the course. We don't consider the starting and ending time of walking, swimming and driving. The distance increases at a constant speed.

Research Design

In the first stage, we set up the random forest model (Carrillo Vera & Aguado Terrón, 2019), Light GBM model and GBR gradient enhanced regression tree model (Hamari & Sjöblom, 2017) to train the weight of various features in the PUBG game. We evaluate the advantages and disadvantages of different models through four evaluation indexes: accuracy, average absolute error, mean square error and goodness of fit, so as to select the most suitable model for our second stage and make the accuracy of the second stage real-time prediction accurate. Finally, we choose the random forest model from the comprehensive perspective of accuracy, mean absolute error, mean square error and goodness of fit.

In the second stage, taking all the members of "chicken eating" team as an example, the ranking prediction model trained by random forest algorithm is used. At the same time, the game log data is obtained from the official PUBG API, and each influencing factor in the data set is mapped and converted with the data items of the game log. Then extract the final player ranking data. Get each player's "winplace" data from match data. Determine the time interval, that is to define the "real-time prediction", put the data into the prediction, and get the ranking of each player. Compare the predicted results of each segment with the real ranking, evaluate and continue to train the model. The accuracy of the prediction results and its change trend with time were observed. Finally, the model was evaluated.

RESEARCH MODEL

Random forest (RF) is an ensemble classifier based on Bagging, which is composed of several fully grown decision trees (Chen *et al.*, 2019). In classification prediction, the class label of the sample is determined by the mode of the output class label of these decision trees (Jonasson & Thiborg, 2010). The training set of each decision tree in RF is generated by self-help resampling, that is, n samples are randomly selected from the original training set with N number. Some samples may be

extracted many times under self-service resampling, while others may not be extracted. According to statistics, the training set of each decision tree contains 2/3 samples of the original training set, while the remaining 1/3 samples which are not extracted form out of bag data (OOB data) to calculate the importance of features. When building a decision tree, random forest extracts \sqrt{d} attribute from d attributes randomly. Then, according to Gini gain maximization principle, it selects the attribute with the best classification ability as the splitting attribute, and divides the data of nodes into new sub nodes. Gini value is often used to measure the purity of data D , and its calculation formula is as follows:

$$Gini(D) = 1 - \sum_{k=1}^{|y|} p_k^2 \quad (1)$$

p_k represents the proportion of the k th class label in the data. $|y|$ is the number of category label values. $Gini(D)$ reflects the probability that two samples are extracted from data set D with different categories. Therefore, the smaller $Gini(D)$, the higher the purity of dataset D . Gini gain obtained by splitting data set D according to attribute a can be calculated as follows:

$$\Delta I_G(a) = Gini(D) - \sum_{v=1}^V \frac{|D^v|}{|D|} Gini(D^v) \quad (2)$$

V is the number of types of value a , and $|D^v|$ is the number of samples corresponding to the value of v . The Gini gain maximization principle is to calculate the Gini gain of all attributes of a node, and select the attribute with the largest Gini gain as the splitting attribute. According to this principle, the split attribute can make the sub node dataset with the highest purity, which shows that the classification performance of this attribute is the best. The better the classification performance, the more important the attribute is in the feature set, so the importance of the feature can be reflected according to the node division of the decision tree. However, due to the double random mechanism of random forest, it is not advisable to use the frequency of attributes in the random forest decision tree to reflect the importance of features. Therefore, in order to reflect the importance of features more accurately, this paper chooses the method based on the classification accuracy of verification set to measure the importance of features. Assuming that there are k decision trees in RF, the importance of feature a can be obtained by the following steps:

- 1) When $k = 1$, self-help resampling is used to generate training set and out of bag data set, and decision tree T_k is constructed on the training set;
- 2) Based on T_k , the OOB data are predicted and classified, and the number of samples with correct classification is counted as R_k ;
- 3) A new OOB sample set is obtained by disturbing the value of characteristic a in OOB. Then, T_k is used to classify and predict the new OOB sample set, and the number of correctly classified samples is counted and recorded as R'_k ;
- 4) Let $k=2, 3, \dots, K$, Repeat steps 1 to 3;
- 5) The importance of characteristic a can be calculated as follows:

$$IMP(a) = \frac{1}{K} \sum_{k=1}^K (R_k - R'_k) \quad (3)$$

If the value of feature a is disturbed, the classification accuracy does not change much before and after the disturbance, which indicates that feature a plays a small role in classification and the classification performance is low. At this time, the value of $R_k - R'_k$ will be very small, so the higher the $imp(a)$, the better the classification performance of feature a .

DATA ANALYSIS

Data Processing

After obtaining huge data, it is necessary to clean the data, otherwise it will affect the efficiency and results of the experiment. Due to the large amount of data collected, we import the data sets into the database on the cloud server, sort them according to the competition, and export the first 100000 pieces of data as experimental data sets. At the same time, we judge whether there is missing value through `is_null()` function. If there are less missing values in the experimental data set, the missing data will be deleted and the data will be re-selected if there are more. In the selected experimental data set, the result of missing value check is that there is no missing value. In order to ensure the uniqueness of the collected data, it is necessary to check the duplicate of the data. Because a player can only participate in one team in a game, a new data item can be formed by combining the player ID, team ID and game ID, and the duplicate can be checked through the data item. At the same time, not every game has 100 players. The difference in the number of participants will lead to different meanings of other features. Obviously, it is more difficult to knock down 5 players in a 90 player game than in a 100 player game, which means that the player's strength is stronger. Therefore, to deal with the distribution of the data items affected by the number of participants, the method of reassignment is to subtract the weight of the actual number of participants from 100 people.

The generation of outliers may be due to errors in the collection of data sets, or the use of plug-ins by players during the game. In this study, we do not study plug-ins, so we remove outliers directly from the data set. Because the data value of the data item

is 0, it is not suitable to use the box diagram method to detect the abnormal value. System data items and player's inherent data items should not have abnormal values, and the main object of processing is the data generated by players in the game. In the visualization process, there are obvious outliers in the data: kills is greater than 30, which is the level that ordinary players can't reach; the number of participants is less than 85, such a game has no reference value, so the data of these games are deleted. In addition to the outliers of individual data items, there are also data exceptions when discussing multiple data items. The solutions are as follows: 1) there is no movement in the whole game, but there is kill data. The created data item distance is the sum of ridedistance, swimmdistance and walkdistance, which represents the global moving distance. Find out the data whose kills is greater than 0 and distance is 0 and delete it. 2) The rate of head burst is high and the number of people killed is more. Create data item snapshot_Rate, which is the quotient of the number of hits and the number of kills. Find out that the kills are greater than 5_ Data with a rate equal to 1 and deleted.

In the experimental data set, there are many feature items, and some of them have little correlation with the research problem. We reduce irrelevant features and redundant features by feature selection. The method used is filter. A filtering method of "correlation statistics" is designed to calculate the features, set a threshold to select, and finally to train the learner. Because our problem is a regression problem, we choose to use the correlation coefficient method for feature selection. The correlation coefficient between each feature and winplaceperc (percentage ranking) was calculated. The threshold value was set as absolute value, and the correlation coefficient between 0-0.09 was no correlation. The final calculation results show that the characteristic items whose absolute value of correlation coefficient is less than 0.09 are killpoints, matchduration, maxplace, numgroups, rank points, road kills, team kills and vehicle destroys Therefore, these characteristics were excluded in the experiment.

Table 1: Characteristic correlation coefficient table

Characteristic item	correlation coefficient
assists	0.307821213
boosts	0.63847773
damageDealt	0.450121504
DBNOs	0.286132604
headshotKills	0.280731682
heals	0.431013528
killPlace	-0.726740931
killPoints	0.011517781
kills	0.430925331
killStreaks	0.374426971
longestKill	0.410889786
matchDuration	-0.002643288
maxPlace	0.036413025
numGroups	0.037417883
rankPoints	0.015676896
revives	0.243392452
rideDistance	0.354353049
roadKills	0.03527861
swimDistance	0.145687882
teamKills	0.015653821
vehicleDestroys	0.072103196
walkDistance	0.817316682
weaponsAcquired	0.619227354
distance	0.686146091
winPoints	0.005982689

Source: This study.

Experimental Process

In the first stage, the three models are operated in the same way and the results are compared. Firstly, the data set after data cleaning and feature selection are imported. We defined function, the data set is divided into training set and verification set. This experiment set "Val" _ Perc = 0.2 ", that is, the data set is divided into training set and verification set according to the ratio of 8:2. After the data set is divided into training set and verification set, the dimension of the data set is checked. And adjust the model parameters continuously. Adjust the parameters, run the model and get the results. Different features have different importance in the prediction model based on Stochastic Forest algorithm. By calculating the importance index of different features in the current model, the results show that the importance of "killplace", "ridedistance", "boosts" and "weapons acquired" is relatively high for the prediction model. However, the importance of "headshot kills" and "revives" to the prediction model is low. We set the importance index greater than 0.005 as the more important features, and retain these more important features. According to these important eigenvalues, a new data set is generated, and the training set and verification set are redesigned. Then the model algorithm is used to set the parameters, and finally the model training and prediction are carried out again.

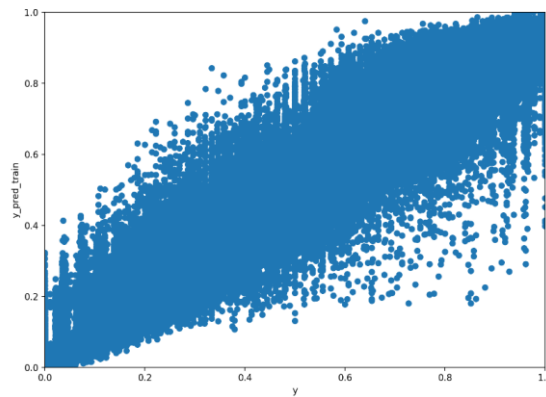

Source: This study.

Figure 1: Forecast results

In the second stage, we can only predict one player at a time, so we need to select some players for experiment. In this paper, we select the final chicken eating team (ranking first), predict the real-time ranking of each team member, and evaluate the results. First, the log events are mapped to the dataset to get the following table.

Table 2: Table log events correspond to datasets

Dataset1	Dataset2
assists	LOGPLAYERKILL
boosts	LOGPLAYERKILL
Damage Dealt	LOGPLAYERKILL
DBNOs	LOGPLAYERKILL
Head shot Kills	LOGPLAYERKILL
heals	LOGHEAL
killPlace	LOGPLAYERKILL
kills	LOGPLAYERKILL
killStreaks	LOGPLAYERKILL
LongestKill	LOGPLAYERKILL
revives	LOGPLAYERREVIVE
rideDistance	LOGVEHICLERIDE LOGVEHICLELEAVE
swimDistance	LOGSWIMEND LOGSWIMSTART
walkDistance	LOGPLAYERPOSITIN

	LOGPLAYERPOSITION
Weapons Acquired	LOGITEMPICKUPFROMLOOTBOX
	LOGITEMPICKUPFROMCAREPACKAGE
	LOGITEMPICKUP

Source: This study.

Then the log data of the target player is extracted, and the corresponding data items are obtained or calculated from the log data, and the time items are converted into formats. Finally, they are saved into different data item meta groups. Then get the start and end time and duration of the game. The next step is to encapsulate the function, which is called in real time during prediction. The function is to determine whether there are events in the time period. If so, the corresponding statistical items will be returned to form the data set of the input model. Then determine the time interval for real-time prediction and evaluate the results. Finally, we use Python's chicken diner and code base to visualize the log, generate game playback animation, and intuitively understand the game process.

Experimental Results

In the first stage, the prediction accuracy was 0.9068, MAE was 0.06917, MSE was 0.0087 and R² was 0.9068. After training, the prediction accuracy was 0.9084, MAE was 0.06873, MSE was 0.0086 and R² was 0.9084. To view the importance of different features in the current prediction model based on random forest algorithm, among the 16 features included in the data set, "killplace", "ridedistance", "boost", "weaponsacquired" and other features are more important for the prediction model. However, the importance of "headshot kills" and "revives" to the prediction model is low. The prediction accuracy and Mae error of Light GBM model are 0.8997 and 0.0735 respectively. The final prediction accuracy of GBR gradient enhanced regression tree model was 0.9026, MAE was 0.06977, MSE was 0.00877 and R² was 0.9063.

In the second stage, the final winning rate of four players is 0.9303726, 0.93701894, 0.92822162 and 0.89602357 respectively. The fluctuation chart of real-time winning rate is as follows: (the blue broken line is the final player ranking; the red broken line is our predicted real-time player ranking)

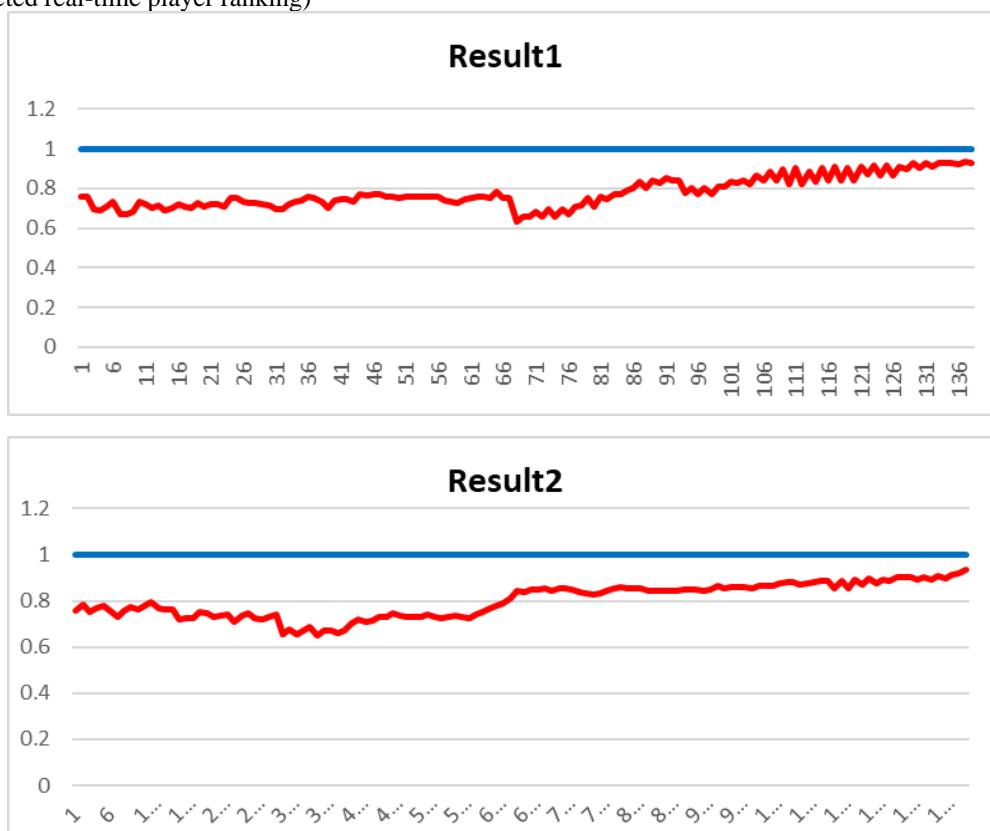

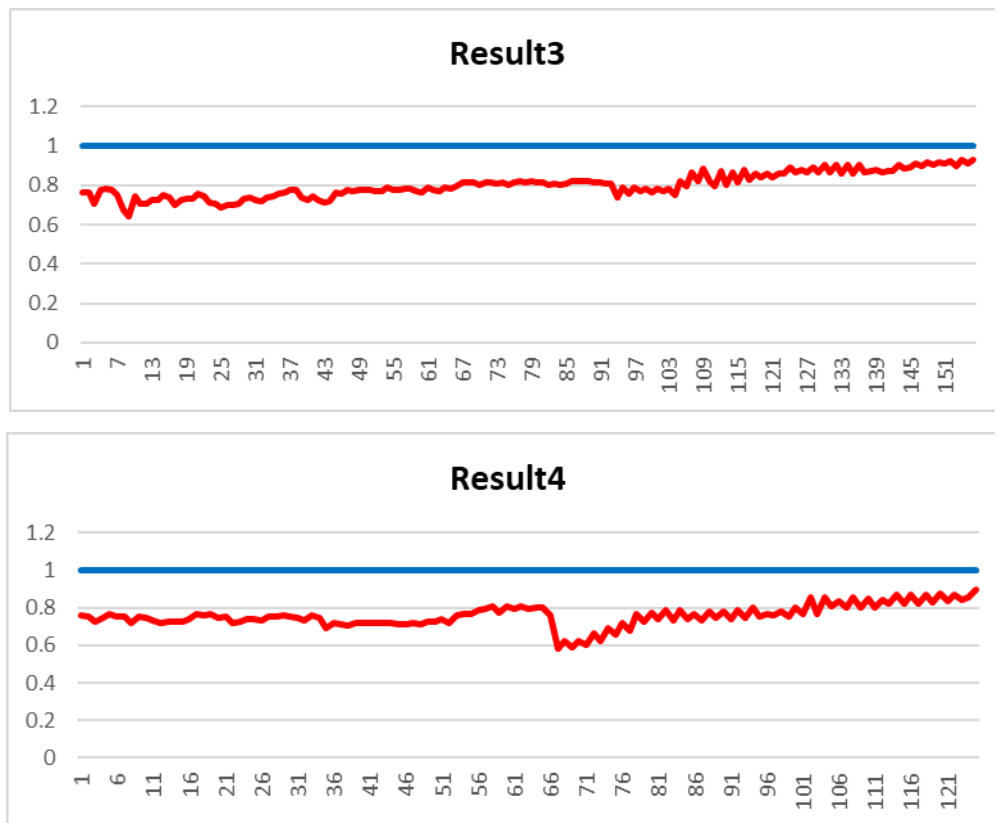

Source: This study.

Figure 2: The fluctuation chart of real-time winning rate

RESULTS AND DISCUSSION

After comparison, we finally choose the model of random forest. For the random forest, the first criterion for evaluating the model is whether the importance of features is distinguished in the process of training, and whether the accuracy of prediction results is improved. From the results, the accuracy of the first experiment is 0.9068. After improving the feature ratio, the accuracy is 0.9084. Compared with the first test, the accuracy is improved by 0.0016. In other words, through the training of random forest, our prediction accuracy has been improved. At the same time, root mean square error is also an important index in error analysis. MSE was 0.0087 after the first calculation and 0.0086 in the second calculation. In contrast, the error is reduced by 0.0001, so the error has been controlled by random forest training. As for the goodness of fit, the R^2 of the first calculation is 0.9068. Then we sift the features to see how much contribution each feature makes to each tree in the random forest, and then take an average value to compare the contribution between the features. In this process, the features of high shadow loudness are "killplace", "ridedistance", "boosts" and "weeks acquired", etc.; while the features of low influence degree are "headshot kills" and "revives". After removing unnecessary features and retaining the features with high correlation, the second calculation of R^2 is 0.9084, increased by 0.0016.

Table 3: Comparison table of prediction results of three models

prediction algorithm	Accuracy	MAE	MSE	R^2
Random forest	0.9084	0.0687	0.0086	0.9084
Light GBM	0.8997	0.0735		
GBR gradient enhanced regression tree	0.9026	0.0698	0.0088	0.9063

Source: This study.

In the aspect of real-time prediction, 10 seconds is taken as a time point to predict the player's ranking at this time. The average absolute error is obtained by comparing with the final ranking. We have got 4 result sets, and made a ranking fluctuation chart of players to analyze the factors affecting the fluctuation. As can be seen from the ranking fluctuation chart, there is a big gap between the real-time ranking and the final result at the beginning of the game. As time goes on, players' real-time ranking approaches the final ranking. This is because in the beginning of the game, players get less equipment, and the density of players is small in a large range of safety area. The probability of fire fighting between different teams is not as high as that of shrinking safety area in the later stage of the game. Therefore, in the process of ranking prediction, the feature related data acquisition is limited, which leads to a large error between the real-time ranking prediction and the final ranking in the early stage of the game, but very close to the final ranking in the later stage.

CONCLUSIONS AND RECOMMENDATIONS

For different features, we use random forest to screen out important features, and rank the features according to the influence degree to improve the algorithm. The results show that the "position of enemies", "moving distance", "number of props used", "degree of weapon destruction" are the most important features in the prediction ranking; the number of heads burst and the number of rescue members are the characteristics of lower importance in the prediction ranking. According to the experimental results, we get the final ranking of players under the given equipment and landing point, and the accuracy of prediction is about 92.29%.

we hope that the model can be further improved to make it more suitable for the actual situation, and the hypothesis premise in the hypothesis space can be more in line with our thinking mode when playing games.

CONTRIBUTIONS AND IMPLICATIONS

This paper aims to predict the player ranking in the game from a new perspective, so as to help the relevant personnel in the e-sports industry. The main contributions of this study are as follows:

Firstly, this paper proposes a real-time prediction method of E-sports. In the aspect of real-time prediction, we can see that the ranking of prediction is limited by the integrity of features at the beginning of the experiment, and the error is very large. In the process of the experiment, the predicted ranking tends to be stable and close to the actual ranking. We track the players in the game in real time, and analyze the impact of their behavior on the results, so as to help players adjust and improve their ranking in the game purposefully and strategically.

Secondly, this paper establishes a model of feature selection, and obtains the weight and change of the characteristics that affect the final ranking in the competition. From the results we get, the influence of characteristics on winning also changes with the number of features. In a certain range, the more weapons and healing items players pick up, the greater the proportion of winning; however, when the number exceeds this range, the winning proportion will not increase with the increase of the number of these two kinds of equipment. The weight of these characteristics and the situation of weight changing with the competition process are of great significance to guide the strategic selection of the team in the E-Competition (Sánchez-Ruiz & Miranda, 2017).

Thirdly, the research results have great practical significance for ordinary users of E-sports games, and can improve their understanding and experience of the game. At the same time, it can also consolidate the mass base of the e-sports industry and promote the development of the whole industry (Ding, 2018). For the e-sports industry, E-sports is an industry with a huge mass base and the number of people who pay attention to it continues to rise (Nascimento Junior *et al.*, 2017). Among various types of games, shooting games represented by "eating chicken" are welcomed by 48.4% of users, second only to MOBA games. We choose the prediction of e-sports, and the results can help a lot of people. For the vast number of game users, by helping users analyze the problems that may be encountered in the game, such as where the first jump is safer, where the materials are the most abundant, and what is the refresh rule of the security zone (Hapfelmeier & Ulm, 2013). The research results help game users improve their game experience. At the same time, it makes the game happy and simple, easier to score. For professional E-sports related personnel, data analysis provides some potential game information for professional players and clubs to help them get higher scores. E-games are becoming more and more popular, so for the spectators watching professional league matches (Jenny *et al.*, 2017), by analyzing the starting position of the team and obtaining material performance, they can more accurately carry out entertainment quiz.

LIMITATIONS AND FUTURE RESEARCH

But our research also has some limitations. Because there are uncontrollable interference factors in the game, such as players' psychological state, players' network fluctuation factors and so on. These data limit the accuracy of the prediction results to a certain extent. We can't get exact control when we control variables, so we don't include uncontrollable factors in this model. In the future research, the distribution, selection and definition of features in different maps should be updated with the updating of maps. And the source and collection of data set should be updated in time, so that the integrity of prediction results is better, the representativeness of training set is stronger, and the accuracy of test set is higher. To sum up, the research on real-time prediction of player's game ranking makes up for the deficiency of current game prediction algorithm to a certain extent, and provides help for the theoretical supplement of machine learning related algorithm and relevant personnel engaged in e-sports industry.

REFERENCES

- [1] Bosc, G., Kaytoue, M., Raïssi, C., Boulicaut, J. F., & Tan, P. (2014, August). Mining balanced sequential patterns in RTS games 1. In *ECAI 2014-21st European Conference on Artificial Intelligence*. <https://hal.inria.fr/hal-01100933/>
- [2] Breiman, L. (2001). Random forests. *Machine learning*, 45(1), 5-32.
- [3] Carrillo Vera, J. A., & Aguado Terrón, J. M. (2019). The eSports ecosystem: Stakeholders and trends in a new show business. *Catalan Journal of Communication & Cultural Studies*, 11(1), 3-22.
- [4] Chen, P., Niu, A., Jiang, W., & Liu, D. (2019, January). Air pollutant prediction: comparisons between LSTM, Light GBM and Random Forest. In *Geophysical Research Abstracts* (Vol. 21).
- [5] Ding, Y. (2018). Research on operational model of PUBG. In *MATEC Web of Conferences* (Vol. 173, p. 03062). EDP

- Sciences. <https://doi.org/10.1051/mateconf/201817303062>
- [6] Hamari, J., & Sjöblom, M. (2017). What is eSports and why do people watch it? *Internet Research*, 27(2), 211-232.
- [7] Hapfelmeier, A., & Ulm, K. (2013). A new variable selection approach using random forests. *Computational Statistics & Data Analysis*, 60, 50-69.
- [8] Jenny, S. E., Manning, R. D., Keiper, M. C., & Olich, T. W. (2017). Virtual(ly) athletes: where eSports fit within the definition of "Sport". *Quest*, 69(1), 1-18.
- [9] Jonasson, K., & Thiborg, J. (2010). Electronic sport and its impact on future sport. *Sport in society*, 13(2), 287-299.
- [10] Keiper, M. C., Manning, R. D., Jenny, S., Olich, T., & Croft, C. (2017). No reason to LoL at LoL: the addition of esports to intercollegiate athletic departments. *Journal for the Study of Sports and Athletes in Education*, 11(2), 143-160.
- [11] Kinkade, N., Jolla, L., & Lim, K. (2015). Dota 2 win prediction. *Univ Calif, I*, 1-13. <http://jmcauley.ucsd.edu/cse255/projects/fa15/018.pdf>
- [12] Nascimento Junior, F. F. D., Melo, A. S. D. C., da Costa, I. B., & Marinho, L. B. (2017, October). Profiling successful team behaviors in League of Legends. In *Proceedings of the 23rd Brazillian Symposium on Multimedia and the Web* (pp. 261-268).
- [13] Pereira, R., Wilwert, M. L., & Takase, E. (2016). Contributions of sport psychology to the competitive gaming: An experience report with a professional team of league of legends. *International Journal of Applied Psychology*, 6(2), 27-30.
- [14] Pluss, M. A., Bennett, K. J., Novak, A. R., Panchuk, D., Coutts, A. J., & Fransen, J. (2019). Esports: the chess of the 21st century. *Frontiers in psychology*, 10, 156.
- [15] Rahman, M. A. (2020). A deep learning framework for football match prediction. *SN Applied Sciences*, 2(2), 165.
- [16] Sánchez-Ruiz, A. A., & Miranda, M. (2017). A machine learning approach to predict the winner in StarCraft based on influence maps. *Entertainment Computing*, 19, 29-41.
- [17] Xiong, S., Zuo, L., & Iida, H. (2014). Quantifying engagement of electronic sports game. *Advances in Social and Behavioral Sciences*, 5, 37-42.
- [18] Ziegler, A., & König, I. R. (2014). Mining data with random forests: current options for real-world applications. *Wiley Interdisciplinary Reviews: Data Mining and Knowledge Discovery*, 4(1), 55-63.

Aging and Urban Mobility in Bandar Sunway: A Holistic Approach

(Full Paper)

Kasturi Rajandran, Monash University Malaysia Genomics Facility, School of Science, Malaysia
kasturi.rajandran@monash.edu

Muhammad Zarul Hanifah Md Zoqratt, Monash University Malaysia Genomics Facility, Malaysia
muhammad.zarul.hanifah@monash.edu

Dexter Shee Zhen Rong, Jeffrey Cheah School of Medicine and Health Sciences, Malaysia
dexter.shee@monash.edu

George Woon Lukic, School of Engineering, Monash University Malaysia
glwoo2@student.monash.edu

Kristel Tan, School of Business, Gerontechnology Laboratory, Monash University Malaysia
kristel.tan@monash.edu

Pei-Lee Teh, School of Business, Gerontechnology Laboratory, Monash University Malaysia
teh.pei.lee@monash.edu

Deepa Alex, Jeffrey Cheah School of Medicine and Health Sciences, Malaysia
deepa.alex@monash.edu

Vineetha Kalavally, School of Engineering, Monash University Malaysia
vineetha@monash.edu,

Shaun Lee Wen Huey, School of Pharmacy, Monash University Malaysia
shaun.lee@monash.edu

Alexandre Rene Schaefer, Jeffrey Cheah School of Medicine and Health Sciences, Malaysia
alexandre.schaefer@monash.edu

Jamuna Jairaman, Laboratory Services, Allied Health Services, Sunway Medical Centre, Malaysia
jamunaj@sunway.com.my

Chieh Lee Wong, Haematology Department, Sunway Medical Centre, Malaysia
wongchiehlee@hotmail.com

Qasim Ayub, Monash University Malaysia Genomics Facility, School of Science, Malaysia
qasim.ayub@monash.edu*

ABSTRACT

Human longevity is constantly changing the demographic outlook of the world's population and older people are projected to double in the next 30 years from 11% to 22% of the world's population. Malaysia is no exception and, like most western and developing nations, the number of Malaysians aged 60 years and above has been gradually rising from the 1970s onwards and is currently estimated to represent 10% of its population. This has created an urgent need to develop age-friendly cities, so that older individuals living in urban areas can have an improved life. It is important that the aging population continues to lead healthy and productive lives as far as possible. In this project, which is a work in progress, we surveyed a suburban community, aged 50 years and above, residing in Bandar Sunway and its vicinity in the state of Selangor Darul Ehsan, Malaysia. The aim was to assess their health and perceptions on mobility through targeted questionnaires, in-depth interviews and focus groups and identify the factors associated with healthy aging in a holistic manner. The overall goal is to promote a healthy mind in a healthy body despite the advancing years. In the preliminary phase we surveyed 73 participants aged between 52 – 85 years and compared responses and clinical parameters for individuals below (N = 36) and ≥ 65 years (N = 37) in age. Based on their Body Mass Index (BMI), the participants were generally healthy with a normal BMI (45%) or slightly overweight (41%) with a higher BMI and blood lipid levels. There were no significant differences in the cognitive assessments between the two age groups ($p = 0.945$). A majority (70%) of the participants were satisfied with their lives in Bandar Sunway, but some reported several health related issues and chronic diseases. However, this was not a factor that hindered their quality of life. Older adults in Bandar Sunway still preferred driving their own vehicles instead of taking public transports. This was due to several shortfalls in the transportation systems: pricing, schedules of transport, safety, and cleanliness. Preliminary results have identified several aspects of public transportation in urban areas that can be improved to better serve the aging community. In doing so, we anticipate the findings and recommendations will be applicable to a much wider community in Malaysia and other parts of the world. The project is aligned with the theme of improving health and well-being and will provide a model for understanding and dealing with aging in the local community.

Keywords: Gerontechnology, aging population, mobility, age-friendly city, health, Malaysia

*Corresponding author

INTRODUCTION

Population aging has been actively changing the world's demography. With the rapid advancements in medicine and technology, life expectancy has significantly increased and is projected to continue to rise. Coupled with the declining fertility rates and the aging of the "baby boom" generation, the older population is estimated to double in numbers from 11% to 22% by 2050 (Bloom *et al.*, 2011).

Malaysia, like the rest of the world, is rapidly facing an aging population. It has been estimated that there are about 3.5 million (10.7%) individuals aged 60 and above in the country in 2020 (Department of Statistics Malaysia, 2020). It is essential to ensure that the individuals in this age group continue to lead a healthy, productive, and comfortable life. Therefore, this study aimed to examine factors affecting urban mobility and healthy aging in the adult population aged 50 years and above. Healthy aging is defined as a dynamic process that facilitates wellbeing in old age, considering functional capacity as one of the core components in the health of older dwellers. Preservation, development, and rehabilitation of the functional capacity of aging people will assure them of the comfort of their daily life and routine, allowing them to live independently, even in the presence of health complications (Fogal *et al.*, 2019).

Older adults are prone to a multitude of health conditions in their lives, which comes with age and general lifestyle. Some common ailments include sensory changes like the loss of eyesight, hearing and cognitive decline. They also tend to experience loss of muscle strength and frailty. This is further enhanced if there is a lack of exercise or mobility. Chronic conditions such as cardiovascular diseases, hypertension, cancer, arthritis, and diabetes are also prevalent in older adults (Jaul and Barron 2017). Most older adults with a lack of physical activity and unhealthy lifestyle were found to be diabetic, which increases the risk factor for other somatic conditions, primarily cardiovascular diseases, and osteoarthritis (Kirkman *et al.*, 2012; Odden *et al.*, 2014). In previous studies other conditions, such as urinary incontinence, dementia and depression were found to be frequently diagnosed in older adults (Collerton *et al.*, 2010).

Mobility is important to health, even more so in older people. Moving even short distances at high frequencies daily were found to positively benefit the health of older individuals (Corran *et al.*, 2018). Mobility disability has been correlated with the possibility of experiencing a fall. In older adults, falls occur in about 30-40% of older adults each year and are a major cause of morbidity (He *et al.*, 2014). Urban environments present new challenges in mobility and safety for the older adults and this requires the implementation of novel measures to reduce the incidents of accidents and falls. In previous studies it has been highlighted that gender, employment status, lack of access to personal vehicles, lack of public transportations and disabilities were some of the key factors that influenced travel among older adults (Corran *et al.*, 2018; Koh *et al.*, 2015).

One of the ways of enhancing the lives of an aging population would be to build a city that would be friendly to them. This concept was highlighted by the World Health Organisation in 2006, to improve liveability of cities for an aging population as well as residents of all ages. This initiative is a 'place-based policy' and its interpretation varies from place to place but essentially, with the same goal (Murray, 2014). Our current study was localised to residents aged 50 and above living in Bandar Sunway (Sunway City), a suburban area in the Petaling District of Selangor Darul Ehsan state in Peninsular Malaysia. The study aimed to investigate the key issues faced by the older dwellers living in this city, and its vicinity, in relation to the urban mobility, and assess the health and wellbeing of the older dwellers to help develop a better understanding on the gap in the current urban mobility.

METHODS

Study area

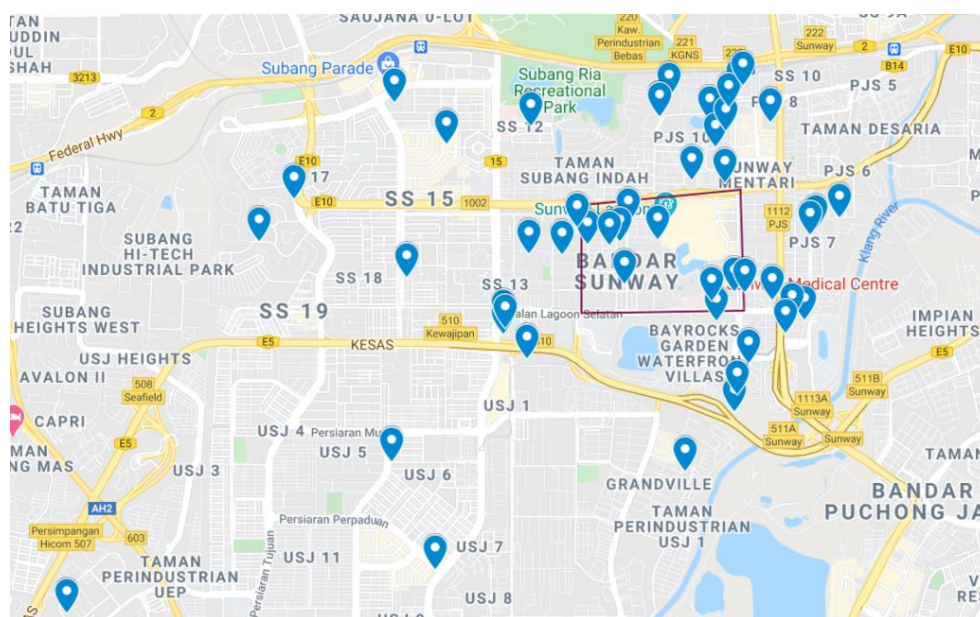

Figure 1: Map depicting Bandar Sunway (in red box) and its surrounding area with markers indicating the participant's residence

Residents living in Bandar Sunway or its vicinity were surveyed over a three-day period in December 2019 (Figure 1). The location is Malaysia's first integrated township located in the Klang Valley in the state of Selangor Darul Ehsan and was transformed from abandoned tin mining land. The area covers approximately 800 acres and includes a population of 200,000. The study was approved by the Monash University Human Research Ethics Committee (Ref #: 2020-19083-41584).

Study subjects and design

A total of 73 participants were recruited for this study using several means. These included placing posters at places frequented by the target group, approaching potential participants and organising a recruitment event on campus. The volunteers were then subjected to various tasks evaluating their physical health, cognition and other lifestyle aspects. These tasks were grouped into three work packages, discussed below.

Work package 1 - General survey questions: Participants were required to fill in a questionnaire with several sections encompassing different aspects of this study. The first part of the questionnaire consisted of demographic information, health status of participants and their mobility and modes of travelling in the city. The second part of the questionnaire aimed to understand the kind of lighting conditions that older residents are exposed to and prefer. The last part of the questionnaire was a psychometric analysis, consisting of a six-question scale measuring anxiety, the State-Trait Anxiety Inventory (STAI-6) and a 5-item scale measuring life satisfaction, the Satisfaction of Life Scale (SWLS) (Diener *et al.*, 1985; Tluczek *et al.*, 2009).

Work package 2 - Clinical laboratory testing and genetic analysis: Peripheral venous blood samples (5 ml) were collected by a certified phlebotomist after obtaining informed consent from each participant for lipid screening as well as vitamin B₁₂ quantification. The blood profiling was carried out at Sunway Medical Centre. Preliminary clinical results are presented here and detailed genomic analysis of genetic variation at selected loci on the Dopamine Receptor D4 (*DRD4*) and Apolipoprotein E (*APOE*) genes are in progress. These loci were selected based on their association with cognition and sensory perception.

Work package 3 - Cognitive assessment: Cognitive assessment of the participants was based on their ability to complete two tasks that are described below:

- **Task 1: Word recall test:** Participants were verbally presented a list of 16 words, read aloud one a time (with a 1 second interval in between word presentations) by the experimenter. The protocol used for this stage was modified from a previous study (Nieuwenhuis-Mark *et al.*, 2009). Their task was to memorize these words as best as they could, to be verbally recalled by them in any order at a later point in time. The first time point in which they were instructed to recall the words was immediately after the presentation of the list of 16 words, as described previously. The second time point is after the completion of Task 2, as described below.
- **Task 2: Tower of London:** In this task, three wooden pegs of different lengths mounted on a piece of wood and three coloured balls (red, blue, green) were used as manipulation pieces, for the purpose of measuring decision making and planning ability. Participants manipulated these three balls (known as a 'move') on the three pegs from an initial arrangement (known as the 'start state') to a desired outcome arrangement (known as the 'goal state'). There are several rules that defined how a 'move' could be made, which were adhered to by the participants (Kaller *et al.*, 2012).

For each trial, participants were verbally informed on the number of ideal 'moves', in which they were tasked to complete the trial (manipulating the coloured balls from the start state to the end state) within a given number of moves. There were a total of 16 trials, with 2 minutes given for each trial to be solved. Participants were also instructed on the importance of mentally planning the solution, before performing the execution of the series of moves. Lastly, they were informed and consented to be video recorded, for the purpose of collecting reaction time data and other parameters.

Data analysis

Statistical analysis was carried out using SPSS, version 26 to compare differences between two the cohort groups, those below the age of 65 and those aged 65 and above

RESULTS

In the preliminary phase a total of 73 participants aged between 52 – 85 years were recruited in this study after obtaining informed consent. The main demographic data of the participants are described in Table 1. Participant mean age was estimated to be 65.04 ± 6.63 (SD) years and so subsequent analysis was done comparing individuals below and above 65 years in age (Figure 2).

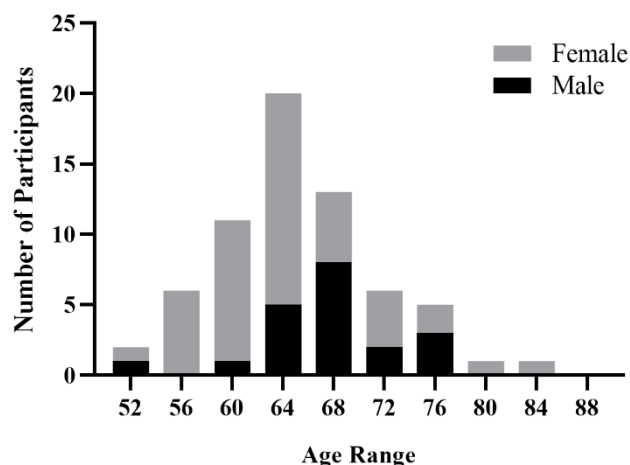

Figure 2: Age distribution of participants of this study, stratified by gender

Physical health and general wellbeing

The Body Mass Index (BMI) of the participants was calculated using the weight (kg) and height (m) data of the participants. Generally, a BMI between 19-23 is accepted as a normal range, with values below the range being underweight and above the range being overweight. Most participants were within the normal range ($N = 33$; 45%) (Table 2) and a similar proportion of them were overweight ($N = 30$; 41.1%). This was a concern as with increasing weight, especially in old age, there will be higher risks of developing certain somatic and physical conditions. Interestingly, 71.2% of participants described their health to be good, very good or excellent indicating that they have a rather positive outlook on their fitness but they did report that they were under medication for several conditions, notably hypertension, high cholesterol and diabetes (Figure 3).

Participants were also prompted to comment on their hearing, eyesight, and urinary incontinence. A total of 86.3% of participant's wear glasses for reading or distance vision with 92% of participants having had their eyesight examined in the last 5 years. On the other hand, only 28.8% of participants have had their hearing tested. About half the participants also reported that in the last week they had to frequently rush to the toilet to urinate during the course of the day, with 23 (36.5%) of them having had urine leak before getting to a toilet.

Table 1: Demographic data of the study participants.

Variable	Category	N = 73	%
Gender	Male	24	32.9
	Female	49	67.1
Marital Status	Not Married	11	15.1
	Married	51	69.9
	Widowed	9	12.3
	Divorced	1	1.4
	Living with a partner	1	1.4
	Highest Education	Primary and below	12
	Secondary	29	39.7
	Diploma/ Pre-University	14	19.2
	Bachelor's degree/ Professional Qualification	11	15.1
	Postgraduate	7	9.6
Ethnicity	Malay	2	2.7
	Chinese	57	78.1
	Indian	13	17.8
	Others	1	1.4
Employment Status	Employed, working full time	13	17.8
	Employed, working part time	6	8.2
	Unemployed	6	8.2
	Retired	41	56.2
	Disabled, not able to work	2	2.7
	Others	5	6.8

Health Perception	Excellent	4	5.5
	Very Good	17	23.3
	Good	28	38.4
	Fair	19	26.0
	Poor	3	4.1
	Don't Know	1	1.4
	Prefer not to answer	1	1.4

Table 2: Age group and Body Mass Index of the study participants.

Variable	Category	Age Group		Total
		Below 65	Above 65	
Body Mass Index (BMI) (weight in kg) / (height in m)²	<19	3	4	7
	19 - 21	7	6	13
	21 - 23	11	9	20
	>23	14	16	30
Total		35	35	70

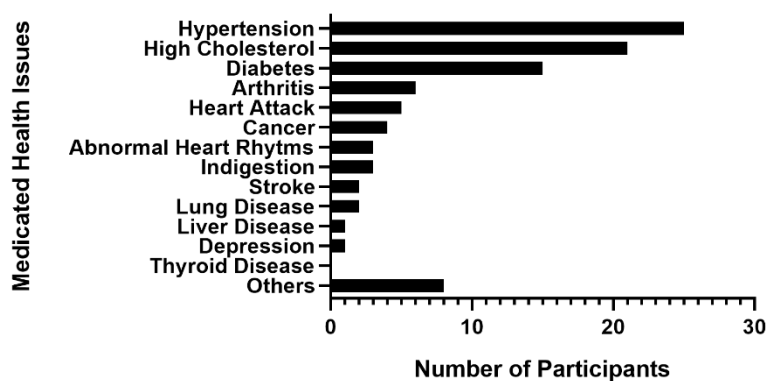

Figure 3: Health conditions that the participants take prescribed medication for.

Clinical laboratory testing

We also compared the lipid profile variation of the participants based on their age, gender, ethnicity, weekly activity, and BMI. The lipid profiles were generally similar between these variables and there were no significant differences observed with a multivariate analysis. However, on average participants had higher than normal levels of total cholesterol (6.56 ± 2.01 mmol/L), triglycerides (2.77 ± 1.52 mmol/L) and low-density lipoproteins (LDL) (3.94 ± 1.51 mmol/L) and low levels of high-density lipoproteins (HDL) (1.29 ± 0.37 mmol/L). The profile also indicated on average, a high risk of developing cardiovascular complications with a cholesterol ratio (5.22 ± 1.53 mmol/L). Out of the 52 participants who had very high total cholesterol levels, only 21 of them were under medication for high cholesterol (Figure 3).

Quality of life measurements

A majority (74%) of the participants described themselves as retired or not working. Despite that, participants from both age groups primarily reported themselves satisfied with their lives, being in good spirits, happy and full of energy. They were also still keen on their favourite activities and interests and very inclined to leave their homes to do outdoor activities. The responses between the two age groups in their self-reported quality of life assessments were synonymous. The responses to these questions were then compared between male and female participants, and for the question “are you afraid something bad is going to happen to you?”, female participants scored ‘yes’ significantly more often than the male participants ($(\chi^2(1) > 5.554, p = 0.018)$).

Question	Responses							
	Below 65				Above 65			
	Yes	%	No	%	Yes	%	No	%
Are you basically satisfied with your life?	34	94.4	2	5.6	35	94.6	2	5.4
Have you dropped many of your activities and interests?	9	25.0	27	75.0	13	35.1	24	64.9
Do you feel that your life is empty?	8	22.2	28	77.8	3	8.1	34	91.9
Do you often get bored?	8	22.2	28	77.8	7	18.9	30	81.1
Are you in good spirits most of the time?	33	91.7	3	8.3	33	89.2	3	8.1
Are you afraid that something bad is going to happen to you?	15	41.7	21	58.3	34	94.4	28	75.7
Do you feel happy most of the time?	34	94.4	2	5.6	32	86.5	4	10.8
Do you often feel helpless?	5	13.9	31	86.1	5	13.5	31	83.8
Do you prefer to stay at home, rather than going out and doing new things?	12	33.3	24	66.7	14	37.8	22	59.5
Do you feel you have more problems with memory than most?	11	30.6	25	69.4	9	24.3	27	73.0
Do you think it is wonderful to be alive now?	34	94.4	2	5.6	36	97.3	1	2.7
Do you feel pretty worthless the way you are now?	5	13.9	31	86.1	4	10.8	32	86.5
Do you feel full of energy?	29	80.6	7	19.4	29	78.4	8	21.6
Do you feel that your situation is hopeless?	2	5.6	34	94.4	1	2.7	36	97.3
Do you think that most people are better off than you are?	9	25.0	27	75.0	5	13.5	32	86.5

Table 3: Participant quality of life assessment.

Mental health and mental aging

Memory performance of the participants was assessed using the free recall task. There were two parts to this task: short-term delay recall (SDRGA) and long-term delay recall (LDRGA). It was found that the SDRGA was significantly positively correlated with the LDRGA ($r = 0.541$, $p < .05$) when this pair was compared (Table 4). There was also a significant average difference between performance in SDRGA and LDRGA ($t_{69} = 6.913$, $p < .05$). (Table 5)

Table 4: Paired Sample Correlation output for the SDRGA and LDRGA data.

Paired Samples	SDRGA Outliers and LDRGA Outliers	N	Correlation	Sig.
		70	0.541	0.000*

Paired Samples	SDRGA Outliers and LDRGA Outliers	95% Confidence Interval of the Difference							
		Mean	Std. Deviation	Std. Error Mean	Lower	Upper	t	df	Sig. (2 tailed)
		0.123	0.149	0.018	0.088	0.159	6.913	69	0.000*

Table 5: Paired Sample T-Test for the SDRGA and LDRGA data.

Participants were also required to complete the Tower of London assessment which functions to analyse the ability to plan. There were no significant differences between the age groups (above and below 65) in the Tower of London General Accuracy measure ($t_{70} = -.069$, $p = .945$). Vitamin B12 levels of the participants were also not significantly associated with the free recall task data and the Tower of London data.

As the last step of the questionnaire, participants filled in two sets of scales, measuring anxiety and satisfaction with life respectively. In the State-Trait Anxiety Inventory (STAI-6) scale analysis, there were no significant variance in participant responses between the two groups. The mean score for the below and above 65 groups were 11.77 and 10.97, respectively

(Table 6). This represents medium anxiety. On the other hand, the Satisfaction of Life Scale (SWLS) analysis also did not display any significant variances between the age groups. 66.67% of the participants below the age of 65 and 77.78% aged above 65 were satisfied with the life they are living (Table 7).

Table 6: State-Trait Anxiety Inventory (STAI-6) scale analysis data compared between the age groups; below and above 65

Age Group	Mean Score	Frequency					
		High anxiety	%	Medium Anxiety	%	No anxiety	%
Below 65	11.77	8	22.22	13	36.11	15	41.67
Above 65	10.97	6	16.22	20	54.05	11	29.73

Table 7: Satisfaction of Life Scale (SWLS) analysis data compared between the age groups; below and above 65

Scoring	Age Group			
	Below 65		Above 65	
	N	%	N	%
Extremely Satisfied	5	13.89	5	13.89
Satisfied	9	25.00	10	27.78
Slightly Satisfied	10	27.78	13	36.11
Neutral	3	8.33	1	2.78
Slightly Dissatisfied	6	16.67	5	13.89
Dissatisfied	3	8.33	2	5.56
Extremely Dissatisfied	0	0.00	0	0.00

Mobility

Mobility of older individuals are fairly influenced by their social and household environments. In our survey most participants (90.4%) lived with other adults in their homes, either a spouse, children, siblings, relatives, housemates, or domestic helpers with at least 57.6% of the participants living with 2 or 3 other adults. A majority (76.7%) of the participants also reported living in single or double story terrace houses. Most of the older adults also had either a car (79.5%) or a motorcycle license (13.7%) with 91.8% of them having at least one car in their household.

When travelling in Bandar Sunway, some participants reported that they were dissatisfied with the quantity of parking spaces (38.9%) and location of parking spaces (36.6%). They felt positively regarding the on-foot accessibility to parking places (38%), public transport stops accessibility (39.4%), quality of seating in public transports (37.6%) and quality of sidewalks (47.1%).

These participants were also not avid users of public transportation with most choosing to drive themselves to their destinations. The type of public transport and their usage frequency is depicted in Figure 4. Participants reported that they refrained from using public transport due to it being too expensive (9.6%), dirty (4.1%), not comfortable (15.1%), not safe (5.5%), information on transport schedule not easily available (16.4%), unreliable (12.3%), the transport not being frequent (19.2%), long waiting times (19.2%) and lack of knowledge (5.5%). The most common used public transport ticket among the participants was the Touch and Go card (49.3%) followed by MyRapid concession card (27.4%) (Figure 4)

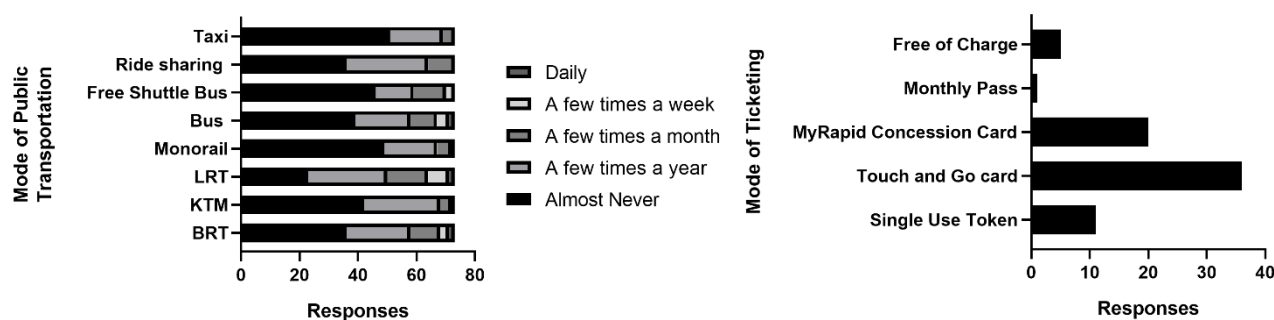

Figure 4: Usage frequency of different public transportations in Bandar Sunway (left) and types of transport tickets favoured by the participants (right).

Some aspects that the participants found were very important in choosing their mode of public transport included real-time updates on transport routes, punctuality of public transport, accessibility of the stops and stations, safety and security while in the transport. Other aspects that were of importance included cleanliness, availability of seats, comfort while waiting for the transport and while in the transport, ticket prices and simple ticketing.

Participants also reported on their frequency of walking around their housing area as well as in Bandar Sunway. Around 60% of the participants reported walking around their area at least a few times a week. The rest of the participants mentioned that they do not walk around their area due to there being too few sidewalks, sidewalks not being maintained, fear of personal attacks, lack of signposting directions and the canopy walk not being well-lit. Participants were also concerned about experiencing a fall, with 25% of them having had a fall in the past year. Among these individuals, 83.3% reported to have a fear of falling again.

Lighting study

We were also interested in examining lighting conditions that participants were exposed to regularly and preferred, and if they had any eyesight disorders. The most common eyesight disorder among both age groups was near-sightedness, far-sightedness, or a combination of both. However, even with these conditions, 64.4% of the participants reported that they did not have any issues with navigating around their homes and around 19.2% reported having some difficulty.

On the lighting study, the cohort from both age groups did not vary significantly on their responses and 86.2% of the participants reported that they generally were exposed to fluorescent or LED lights daily and preferentially use these kinds of lights in their homes. They also preferred to use bright lights in their homes (74%) but were interested in utilising ambient lighting in the future (53%). Most of the participants in this study enjoyed being outdoors and 86.1% of them reported to be exposed to at least 4 hours of sunlight each day. In terms of quality of sleep, 93.2% of them reported to sleep well, with 91.8% of them preferring to sleep with lights off. Additional data analysis is in progress.

DISCUSSION

This study was designed to understand the daily life of the older generation living in Bandar Sunway and on the issues they faced in terms of mobility within the city. We also identified the physiological and mental health of the participants as a holistic way in creating the ideal aging-friendly city. Preliminary analysis indicates that in general the participants are positive and happy with their lives and have a high interest in going out and socialising. They were also independent in their daily lives and were able to maintain their homes, cook meals, groom themselves and take their medications on their own. In the quality of life analysis, participants in both age groups were generally satisfied with their lives and were positive in responses. These responses could also probably be attributed to the participants not being isolated from others. Loneliness was found to be a key contributor in depressive states and a lower quality of life in older adults, in a study conducted in Singapore (Lim & Kua, 2011). However, for the question on if participants were anxious about something bad happening to them, female participants significantly said yes. This finding correlates to previous studies describing older females to be three times more likely to display signs of anxiety than their male counterparts (Vasiliadis *et al.*, 2020). The STAI-6 scale data also indicated that older individuals living in Bandar Sunway, do have mild anxiety but were still generally content with their life; 72.23% on the SWLS Scale.

Although most participants scored themselves as healthy, their BMI and lipid profiles indicated otherwise. High levels of body fat have a direct association with the presence of cardiovascular diseases and other comorbidities, such as diabetes and hypertension (de Souza *et al.*, 2015). Only a small fraction of the participants who had high risk lipid profiles were on medication for their condition. This presents an important area for improvement in the future, where yearly general health screening should be easily available to and recommended to older people.

Most participants reported to be bespectacled and some had hearing issues. Future planning for city upgrades should consider the physical disabilities of these individuals including having a larger font size in signboards and sound cues with vision cues at crossings. About half the participants also reported that they had to frequently urinate during the entire day. This could be a hindrance in quality of life, especially in individuals experiencing incontinence. They would be very limited in terms of their activity range and travel durations and distances. It would be important for these individuals to have access to a toilet when they need it.

In the Free Recall Task, we observed the expected difference between the SDRGA and LDRGA. Older participants were found to have difficulty in mentally 'going back in time' to when the words were recited to them, to recall the list, after some time has passed, unless they make significant emotional association with the words compared to recalling the word list in a short duration (Nieuwenhuis-Mark *et al.*, 2009). Tower of London analysis is a good indicator for the ability of individuals to visualise a problem and on planning to solve it. We did not find any significant differences between the age groups in this analysis, contrary to what we expected. We then compared the data from both the tasks with the participant's vitamin B₁₂ data, but it was not statistically significant. Vitamin B₁₂ plays an important role in neurological development, especially in older adults where a deficiency leads to an age-related cognitive decline (Stover, 2010). We expected participants who performed poorly in the tasks to also exhibit lowered vitamin B₁₂ levels, but this was not the case.

Mobility and physical activity in older adults are extremely important to their wellbeing, as it has a direct influence on the rate of decline in functional capacity (Fogal *et al.*, 2019). One of the major goals in creating an aging-friendly city is to facilitate an environment where older people will not feel reluctant to go about their daily lives. Most participants preferred driving to their destinations and occasionally used public transportation, even though they faced a lot of parking difficulties in the city. A key method to improving the public transportation structure to be attractive to older adults is to have a more straightforward system. Many of them refrained from using public transportation due to the lack of knowledge on the routes, schedules, frequency of service and ticket prices. These, along with comfort and safety are rated as factors that are important to older adults.

It was found in a previous study that the surrounding environment plays an important role in the functional capacity of older adults. Older people living in places that were more walkable had less functional disability as well as were healthier (lower cardiovascular risks) (Fogal *et al.*, 2019). In this study, most participants maintained a good level of physical activity with most of them walking at least 30 minutes, on average 5 times a week and moderate physical activities for 30 minutes on average 3 times a week. Several problems were brought to attention regarding the lack of walking paths and signposts, lighting, and physical safety. In future development projects, attention should be made to improving the sidewalks to better facilitate walking as well as maintaining it. The guarded canopy walk could also be improved with better lighting measures, utilising high-brightness LED lights to ensure comfort when navigating, especially in older people with eyesight disorders (White *et al.*, 2013). This will allow older people to be able to walk even at night in safety and avoid walking on pavements which can be unsafe in late hours.

Based on these findings there are some improvements that can be made in Bandar Sunway regarding enhancing the quality of life and mobility of older adults. However, the findings of this study have to be interpreted with caution due to some limitations. First, the sample analyzed is relatively small (N = 73) and future studies should collect more data including longitudinal data. Second, the sample was collected in a single country (i.e., Malaysia) and predominantly from a Chinese community in Malaysia and these insights might not be generalizable to other cities and ethnicities in the developed and developing countries. It would be essential to consider the general health and disabilities of the older people, while also not excluding people of other ages when making improvements in the city. It would be more beneficial to deliberate an age-friendly city rather than just an aging-friendly city, when planning the ultimate urban utopia for all. We encourage future research to investigate aging and urban mobility in other cities across the world.

ACKNOWLEDGEMENTS

This study was funded by a Sunway Community Grant (SCG-2018-02-SCI). The funders played no role in the conceptualization, design, decision to publish or preparation of the manuscript. Muhammad Zarul Hanifah Md Zoqratt was supported by Monash Malaysia R&D Sdn Bhd. We would also like to thank the following individuals from Monash University who volunteered their time and efforts to make this project a success; Daniel Prajogo, Department of Management, Faculty of Business and Economics; Lee Sui Mae, School of Science, Low Ver Nice, Research Assistant, School of Business, Gerontechnology Laboratory; Mohamed Shajahan Yasin, Jeffrey Cheah School of Medicine and Health Sciences; Motoki Watabe, School of Business; Pervaiz K. Ahmad, School of Business; Sadequr Rahman, School of Science, Tropical Medicine and Biology Multidisciplinary Platform; Susilawati, School of Engineering; Tan Chee Pin, School of Engineering; Yek Sze Huei, School of Science. We also acknowledge the following students who volunteered and assisted during the recruitment drive: Alysha Kaur Sachdev, Anas Mohamed, Annereena Ravichandran, Arjun Nagarajan, Celine Gan Chi Ching, Fadilla Ramadhani Wahyudi, Heerman Kumar Sandra Kumar, Lee Chuen Zhang, Lee Shan Neng, Lim Shu Yong, Nur Zawanah Zabidi, Rinako Cheah, Saw Yi Jiau, Sinthu Subramaniam, Sze Mei Lee and Wong Yen Jun. We also thank Chow Yock Ping and Norziha Zainul Abidin from the Sunway Medical Centre; Joyce Sin Tong Joo, Senior General Manager, Customer & Community Services, Sunway Integrated Properties Sdn Bhd. and Jaqueline Wong, Assistant Manager, Sunway Sustainability Solutions Sdn. Bhd. for their assistance.

Conflict of interest: The authors declare that there are no competing interests

REFERENCES

- [1] Bloom, D. E., Boersch-Supan, A., McGee, P., & Seike, A. (2011). Population aging: facts, challenges, and responses. *Benefits and compensation International*, 41(1), 22.
- [2] Collerton, J., Davies, K., Jagger, C., Kingston, A., Bond, J., Eccles, M. P., Robinson, L. A., Martin-Ruiz, C., von Zglinicki, T., James, O. F. W., & Kirkwood, T. B. (2009). Health and disease in 85-year olds: baseline findings from the Newcastle 85+ cohort study. *BMJ*, 339, b4904.
- [3] Corran, P., Steinbach, R., Saunders, L., & Green, J. (2018). Age, disability and everyday mobility in London: An analysis of the correlates of 'non-travel' in travel diary data. *Journal of Transport & Health*, 8, 129-136.
- [4] de Souza, J. D., Ribeiro, A. Q., Martinho, K. O., Franco, F. S., Martins, M. V., Rodrigues, M. G., ... & Tinôco, A. L. A. (2015). Lipid profile and associated factors among elderly people, attended at the Family Health Strategy, Viçosa/MG. *Nutricion hospitalaria*, 32(2), 771-778.

- [5] Department of Statistics Malaysia. (2020, 15 July). Current Population Estimates, Malaysia, 2020 [Press Release]. https://www.dosm.gov.my/v1/index.php?r=column/cthemByCat&cat=155&bul_id=OVByWjg5YkQ3MWFZRTN5bDJiaEVhZz09&menu_id=L0pheU43NWJwRWVSZklWdzQ4TlhUUT09
- [6] Diener, E. D., Emmons, R. A., Larsen, R. J., & Griffin, S. (1985). The satisfaction with life scale. *Journal of personality assessment*, 49(1), 71-75.
- [7] Fogal, A. S., Pessoa, M. C., Fernandes Filho, E. I., & Ribeiro, A. Q. (2019). Built urban environment and functional incapacity: enabling healthy aging. *Journal of Transport & Health*, 14, 100574.
- [8] He, W., & Larsen, L. J. (2014). *Older Americans with a disability, 2008-2012*. Washington, DC: US Census Bureau.
- [9] Jaul, E., & Barron, J. (2017). Age-related diseases and clinical and public health implications for the 85 years old and over population. *Frontiers in public health*, 5, 335.
- [10] Kaller, C. P., Unterrainer, J. M., & Stahl, C. (2012). Assessing planning ability with the Tower of London task: Psychometric properties of a structurally balanced problem set. *Psychological Assessment*, 24(1), 46-53.
- [11] Kirkman, M. S., Briscoe, V. J., Clark, N., Florez, H., Haas, L. B., Halter, J. B., ... & Pratley, R. E. (2012). Diabetes in older adults. *Diabetes care*, 35(12), 2650-2664.
- [12] Koh, P. P., Leow, B. W., & Wong, Y. D. (2015). Mobility of the elderly in densely populated neighbourhoods in Singapore. *Sustainable Cities and Society*, 14, 126-132.
- [13] Lim, L. L., & Kua, E. H. (2011). Living alone, loneliness, and psychological well-being of older persons in Singapore. *Current gerontology and geriatrics research*, 2011.
- [14] Murray, L. (2015). Age-friendly mobilities: A transdisciplinary and intergenerational perspective. *Journal of Transport & Health*, 2(2), 302-307.
- [15] Nieuwenhuis-Mark, R. E., Schalk, K., & de Graaf, N. (2009). Free recall and learning of emotional word lists in very elderly people with and without dementia. *American Journal of Alzheimer's Disease & Other Dementias®*, 24(2), 155-162.
- [16] Odden, M. C., Shlipak, M. G., Whitson, H. E., Katz, R., Kearney, P. M., Shastri, S., Sarnak, M.J., Siscovick, D.S., Cushman, M., Psaty, B.M., & Newman, A. B. (2014). Risk factors for cardiovascular disease across the spectrum of older age: The Cardiovascular Health Study. *Atherosclerosis*, 237(1), 336-342.
- [17] Stover, P. J. (2010). Vitamin B12 and older adults. *Current opinion in clinical nutrition and metabolic care*, 13(1), 24-27.
- [18] Tluczek, A., Henriques, J. B., & Brown, R. L. (2009). Support for the reliability and validity of a six-item state anxiety scale derived from the State-Trait Anxiety Inventory. *Journal of nursing measurement*, 17(1), 19-28.
- [19] Vasiliadis, H. M., Desjardins, F., Roberge, P., & Grenier, S. (2020). Sex Differences in Anxiety Disorders in Older Adults. *Current Psychiatry Reports*, 22(12), 1-9.
- [20] White, M. D., Ancoli-Israel, S., & Wilson, R. R. (2013). Senior living environments: Evidence-based lighting design strategies. *HERD: Health Environments Research & Design Journal*, 7(1), 60-78.

Application of Artificial Intelligence Technology in Baby Stroller Design

(Full Paper)

Hou Jianjun, Nanjing Institute of Technology, Cultural and Artistic Creativity Design Institute, Nanjing, China, houjianjun@njit.edu.cn

Xu Lijun*, Nanjing Institute of Technology, Nanjing, China, xulijun@njit.edu.cn

ABSTRACT

With the ever-improving development and advancement being made with artificial intelligence (AI) technology, AI has been gradually used to the field of maternal and infant products. This paper systematically studies the theoretical basis and market status of baby strollers, and analyzes the product functions and technical applications of existing strollers. The application of AI technology to baby stroller are summarized from four aspects: more safe protection system, more comfortable user experience, more intelligent use function and more convenient operation mode. Finally, this paper designs an intelligent multi-functional baby stroller which can be used in four ways: baby basket, baby car seat, baby stroller and baby rocking chair. The intelligent design application are added from the intelligent power, intelligent protection, intelligent recognition, intelligent security, intelligent voice, APP interface and sharing rental mode, so as providing theoretical basis and guidance for the design of baby stroller.

Keywords: Artificial intelligence; baby stroller; baby cradle; baby rocking chair.

*Corresponding author

INTRODUCTION

With the emergence and development of Internet technology, Big Data, Cloud Storage, Biochip and Artificial Intelligence (AI), intelligent technology has gradually applied to the field of maternal and infant products. Intelligence baby stroller which based on artificial intelligence technology can make real-time analysis and judgment on the baby's physiology and behavior, and feedback to the guardian through data in time. At the same time, it can make judgments and processing automatically by the surrounding environment.

LITERATURE REVIEW

The theoretical research of baby stroller mainly perspective at infant safety and ergonomic comfort. The main representative studies are as follows: The incidence of injury related to baby strollers among children under aged 5 in the United States from 1990 to 2010 which found that an average of 17187 children were injured by the baby stroller every year, most of which were hurt on head (44%) or face (43%) (Fowler et al., 2016). The main causes of infant injury are the design defects, product performance and guardian wrong use of baby stroller (Frisbee & Hennes, 2000; Powell, Jovtis & Tanz,2002). And the factors influencing the use of strollers are the time, the distance and the baby's preference (Birken, Lichtblau & Lenton-Brym, 2015).

CURRENT PRODUCTS

The brand status of baby stroller

At present, there are two mainly styles of baby stroller: European styles' stroller which is the birthplace of the stroller and dominating the global high-end market, has advanced technology, streamline shape, and the high-level unification of functional and aesthetic. Japanese styles' stroller likes small-sized, lightweight and easy to fold. At the same time, some of the chinese baby stroller brands have increased and occupied market gradually, such as GoodBaby, SeeBaby, Angel, 3Pomelos, etc. The famous brands of baby stroller as shown in Figure 1.



Figure 1: The famous brands of baby stroller

With the application of new material and technology in the baby stroller, the baby stroller is not only more dynamic and modern, also more convenient in operation, more diversified into functions and safer to use. At the same time, there also have the problems as the low rate of being used and few features. New materials, new structures, new functions, artificial intelligence technology and reuse mode are the new directions for baby stroller innovation.

The products of artificial intelligence baby stroller

In recent years, intelligent baby strollers have gradually become popular in the market. For example, the 4moms Origami electric baby stroller has innovative designed functions such as one button opening and automatic folding, built-in motor automatic power generation, body lighting system and LCD instrument panel. The 3pomelos baby stroller has intelligent pressure sensors and smart APP which can monitor the baby's status and remind the guardian at any time. The smartbe intelligent baby stroller has the functions of electronic temperature control baby basket, bottle heater, automatic rocking chair, automatic folding, music playing, electronic lock, anti-theft sensor and three different telescopic covers. The strollever concept stroller has a very science fiction appearance, equipped with gyroscopes inside, which can keep the balance of the vehicle under any external force interference. Nuna Demi Growth can be transformed into 23 modes which can meet the various possibilities of infant life and growth. The products of artificial intelligence baby stroller as shown in Figure 2.



Figure 2: The products of artificial intelligence baby stroller

APPLICATION OF AI TECHNOLOGY IN BABY STROLLER

This paper researched on the existing AI technology and found that the application in baby stroller can be reflected in: more secure protection system, more comfortable user experience, more intelligent use function, and more convenient operation mode. The application of artificial intelligence technology in stroller as shown in Figure 3.

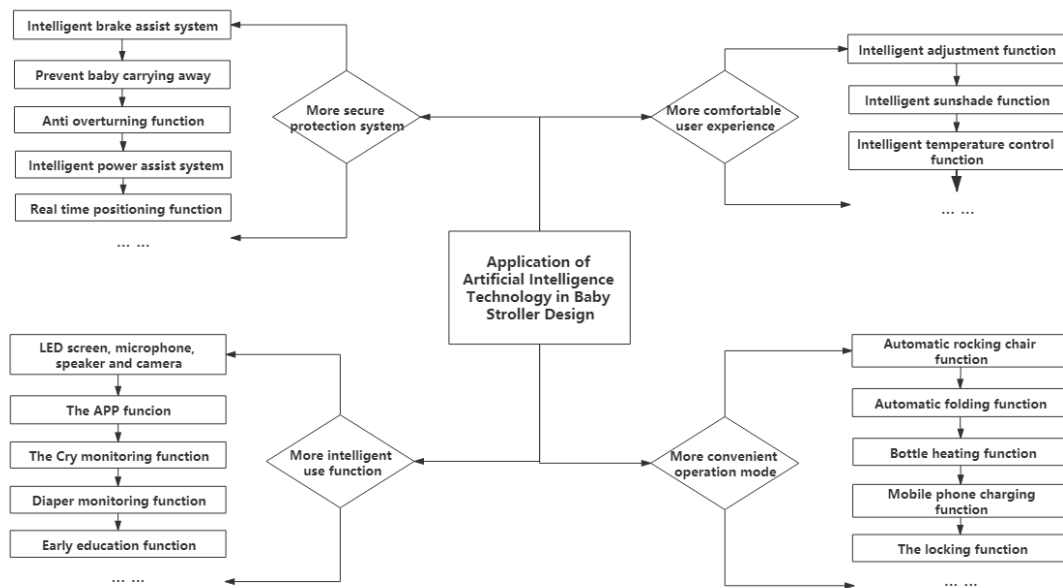

Figure 3: The application of artificial intelligence technology in stroller

More secure protection system

Intelligent brake assist system

The acceleration gravity sensor which can measure the components of the acceleration of gravity of the X-axis and the Y-axis of the acceleration sensor can calculate the angle of the stroller in the vertical direction. The two-axis acceleration sensor can use to measure the plane tilt angle. The three-axis acceleration sensor can use to measure the space tilt angle, and the gravity component of X, Y and Z axes are used to calculate the space tilt angle. When the angle exceeds the default value, the stroller stops and start alarm. The calculation principle of inclination angle θ as shown in Figure 4.

The space tilt angle formula is:

$$\alpha = \arctan\left(\frac{\sqrt{Ax^2 + Az^2}}{Ay}\right) \tag{1}$$

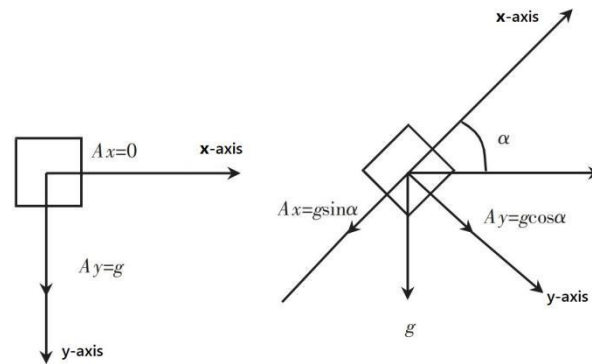

Figure 4: The calculation principle of inclination angle θ

The function of prevent baby from carrying away

The touch sensor on the handle can quickly identify the guardian, and the seat pressure sensor can sense the change of gravity. If a stranger forcibly carries the baby, the system will quickly send a warning signal to the guardian.

The anti-overturning function

The infrared sensor technology can detect obstacles in front of the baby stroller in real-time. If there have obstacle in front of the baby stroller, the infrared sensor will quickly send a signal to the motor, and the motor controls the brake to stop the stroller.

The speed adjustment and intelligent power assist function

The speed sensor technology can sense the change of speed, for example, if the speed of baby stroller is too fast, the speed sensor will give a warning and decelerate the speed. When the baby stroller goes uphill, the angle sensor can detect the angle and transmit signal to the motor, and the motor will give power to the baby stroller to help it go uphill.

The real time positioning function

The internal locator technology can view the real-time position or travel track through APP, and a key can start alarm system in case of emergency.

More comfortable user experience

The intelligent adjustment function

The voice sensor or APP interface can control the angle and height of baby stroller, and help baby change posture intelligently.

The intelligent sunshade function

The light sensor technology can detect the light intensity. When the sunlight intensity on the stroller is higher or lower than the present value, the sunshade will adjust the opening angle and sunshade area according to the light intensity and light direction.

The intelligent temperature control function

The temperature sensor technology can detect the internal temperature of the baby stroller and the baby's temperature. When the temperature is higher or lower than the pre-set value, it will send a prompt to the guardian immediately, and can also adjust the internal temperature of the baby stroller intelligently.

More intelligent use function

LED screen, microphone, speaker and camera

The display screen can monitor the baby's status and operate the baby stroller in real time, the microphone can realize the interaction between the guardian and the baby, the speaker can play the baby's favorite music, and the camera can realize the real-time monitoring and recording of the baby's growth.

The APP function

The guardian can operate the stroller by the display screen or remote control by the mobile APP.

The Cry monitoring function

The sound sensor can collect sound waves to detect the baby's cry and predict the baby's emotion.

The diaper monitoring function

The temperature and humidity sensor technology can sense the seat cushion and remind the guardian of the baby's diaper status in real time.

The early education function

The intelligent chip technology can accord to the physiological and psychological characteristics of baby's age push music, stories, nursery rhymes, etc. which can promote the brain development of babies.

More convenient operation mode

The automatic rocking chair function

The rocking chair function can be automatically turned on to comfort the baby, and the guardian also can use APP to open the rocking chair function.

The automatic folding function

The voice or APP operation can realize automatic folding function of baby stroller, which is convenient for storage or transportation.

The bottle heating function

The bottle heating and heat preservation function enables infants to drink warm milk at any time.

The mobile phone charging function

There have a charging hole is set on the stroller to help the guardian charge the mobile phone at any time.

The locking function

There is a touch sensor on the handle of the monitoring hand. When the monitoring hand touches the handle, the wheel is unlocked, and when the monitoring hand leaves the handle, the wheel is locked. At the same time, voice or APP control baby carriage lock or unlock function. The structure frame diagram of intelligent device as shown in Figure 5.

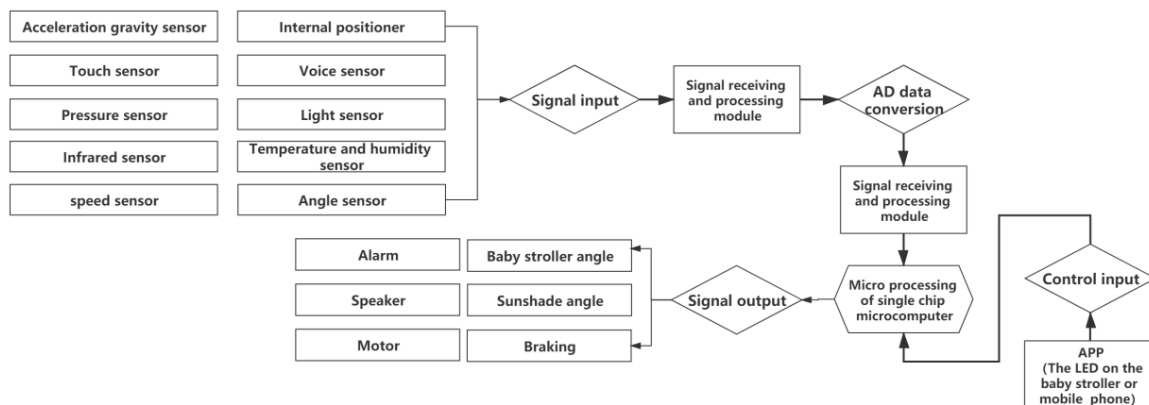

Figure 5: The structure frame diagram of intelligent device

THE DESIGN OF AI BABY STROLLER

The design renderings of AI baby stroller

This design is for infants aged 0-18 months who are delicate and need better protection. At the same time, this product is also designed for parents in the new era environment. Through the artificial intelligence system, it can better solve the communication barriers between parents and infants. This design has the modern design esthetic feeling and technology sense, the multi-function use way fits the baby different functionality. The design of AI baby stroller as shown in Figure 6.

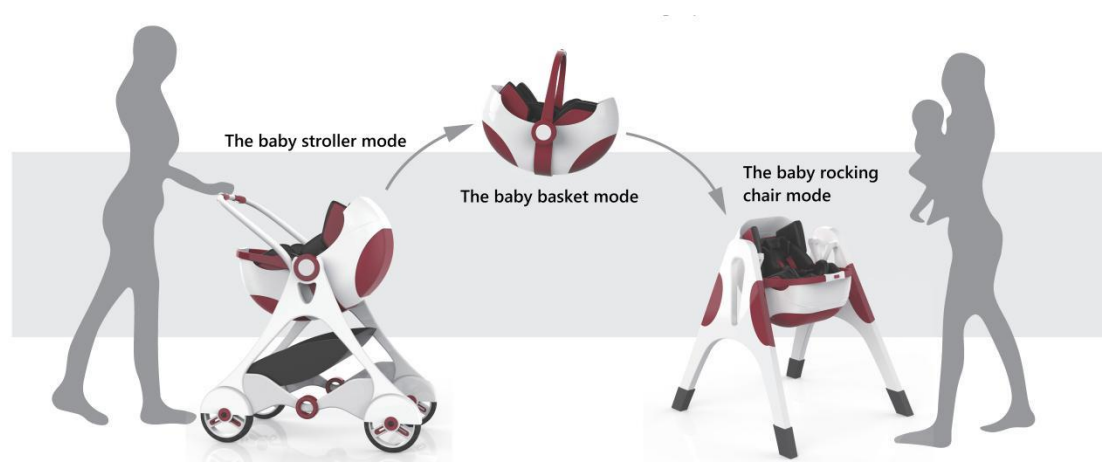

Figure 6: The design of AI baby stroller

There are three structures of this design, which are baby basket, trolley bracket and rocking chair bracket. The different combinations of the above structures can be used in four ways. The baby basket mode: The infants aged 0-18 months who have undeveloped muscles and bones are more suitable for lying down to reduce spinal pressure. When the baby lies in the baby's basket and fasten the five-point safety belt, the guardian can walk by hand through the basket. The car safety seat mode: When the baby lies in the basket and fasten the safety belt, the basket seat is placed on the back seat of the car in reverse. The car safety belt is fixed on the whole safety seat and inserted into the seat belt slot to ensure the safety of the baby when driving. The baby stroller mode: When the baby basket combines with the trolley bracket, the guardian can easily push the baby out for a walk or shopping. The baby rocking chair mode: When the baby basket combines with the cradle bracket, the baby rocking chair mode turns on which can change different speed and at same time plays some early education music. The structure of AI baby stroller design as shown in Figure 7.

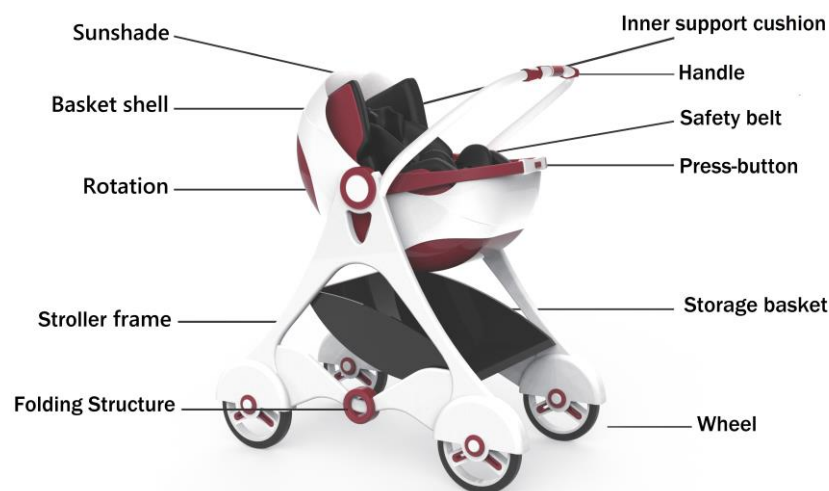

Figure 7: The structure of AI baby stroller design

The application of AI technology in design

This design is based on the existing artificial intelligence technology, according to the baby's physiological and psychological needs, the application of intelligent from the intelligent safety, intelligent power, intelligent protection, intelligent recognition and intelligent voice.

The intelligent security system

The intelligent security system includes fingerprint recognition, face recognition, speed recognition and obstacle recognition. It mainly realizes the functions of intelligent braking when sliding slope, preventing strangers from forcibly taking the baby, preventing the stroller from being too fast or overturn, realizing real-time positioning and set alarm.

The intelligent power system

The intelligent power system includes intelligent brake assist system and intelligent assist function. The baby stroller has two modes: The full-automatic walking mode which the baby stroller can always walk in front of the guardian. The semi-automatic walking mode which the stroller will recognize and move according to the moving speed of the guardian as long as the guardian holding hands on the handle and moves forward. The automatic and semi-automatic travel mode as shown in Figure 8.

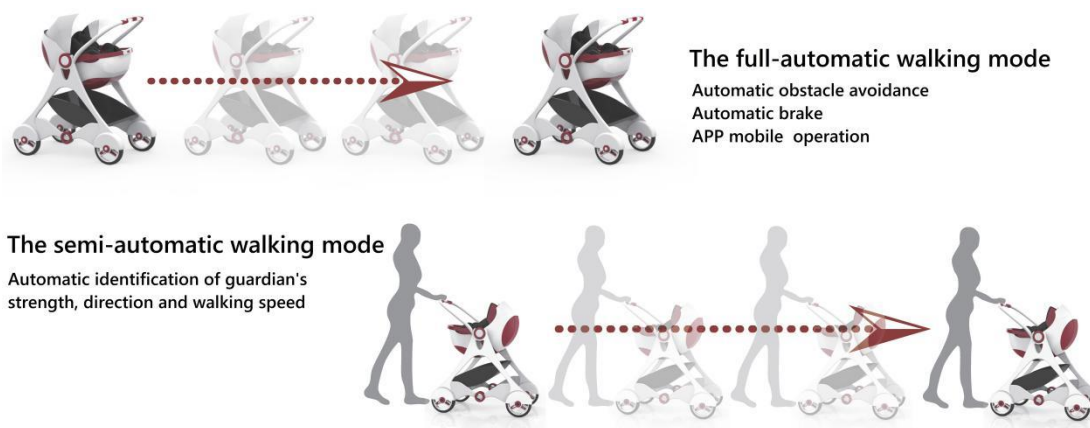

Figure 8: The automatic and semi-automatic travel mode

The intelligent protection system

The intelligent protection system includes intelligent sunshade, intelligent light and intelligent temperature control functions. When the sun radiation is higher than the acceptable safety value, the sunshade will open automatically, and the opening and closing angle of the sunshade can be adjusted according to the sunlight angle. At the same time, the sensor can also detect wind speed and air humidity, and combine with weather forecast to deal with the rain and wind in advance. The intelligent sunshade function as shown in Figure 9.

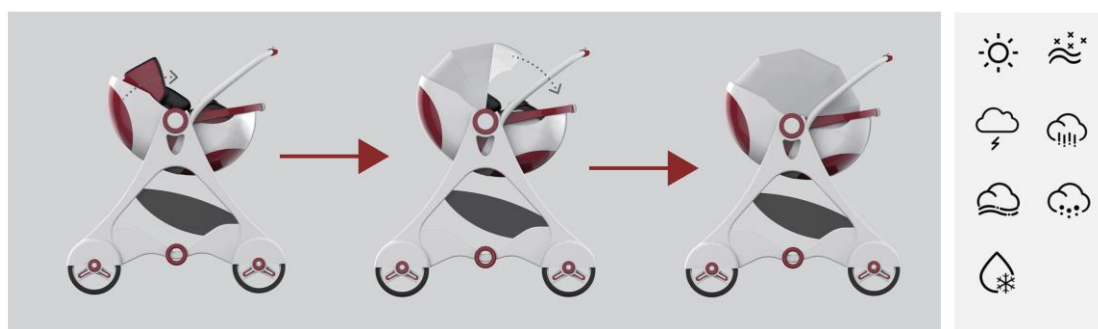

Figure 9: The intelligent sunshade function

The intelligent recognition system

The intelligent recognition system can adjust the angle of the seat cushion according to the baby's posture to make the baby more comfortable. At the same time, the baby's temperature and sweat can be detected, the seat temperature will be adjusted according to different conditions to provide a more comfortable environment for the baby. The baby's seat belt and the handle of the stroller have fingerprint identification function, which can be untied and pushed by the guardian who enters the fingerprint system. There is a sound sensor inside the baby stroller to collect sound waves. When the baby is crying, the rocking chair will automatically swing and play music. If the baby doesn't stop crying, it will send an alarm to the guardian. The details design of baby stroller as shown in Figure 10.

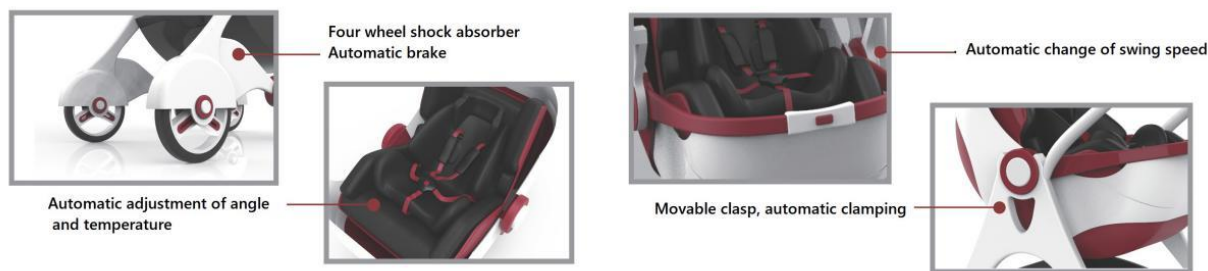

Figure 10: The details design of baby stroller

The intelligent voice system

This design has intelligent speech recognition function which can convert the input emotional voice signal (such as crying) into digital signal, and display it on APP, so as to realize the simple communication between the baby and the guardian.

App interface design

This design combines the various functions of the baby stroller to design the mobile APP interface which including information interface, function operation interface, baby status monitoring interface, intelligent early education and social platform interface, etc. The App interface design of baby stroller as shown in Figure 11.



Figure 11: The App interface design of baby stroller

The sharing mode of baby stroller

As the baby stroller is a short-term product which can only meet the needs of infants aged 0-18 months, the cost also increases by the AI technology which not only brings economic pressure to guardians, but also wastes social resources. Therefore, this design conceives a sharing business model. The company replaces the sales mode by rent mode: after the baby stroller is used, the company will recycle, upgrade the program, replace cushion and other vulnerable parts and disinfect the stroller. After the quality inspection is qualified, the stroller can rent to next user. This mode constructs a green commodity, improves product utilization and reduces environmental pollution.

CONCLUSION

With the continuous application of artificial intelligence technology in maternal and infant products, maternal and infant products are not only more intelligent to meet the physiological and psychological needs of infants and guardians, but also provide more secure protection system, more comfortable user experience, more intelligent use function and more convenient operation mode. This paper not only systematically studied the theoretical basis and market status of the baby stroller, but also analyzed the application of artificial intelligence technology in the baby stroller, and finally designed an intelligent multi-functional baby stroller which can be used in four ways. The intelligent baby strollers design greatly improves the overall safety for the baby and offers many features to help improve the communication between the baby and the guardian, make the overall use and operation of the product more convenient and enjoyable.

ACKNOWLEDGMENT

This research has been supported by the Ministry of Education Human Society project of China (No.20YJC760030), The Philosophy and Social Science project of Jiangsu Province (No.2018SJA0386), the key projects of Teaching Research and Teaching Reform of Nanjing Institute of Technology (No.JG2019009), the First Class Curriculum Construction project of Nanjing Institute of Technology (No.YZKC2019067), the Higher Education Research project of Nanjing Institute of Technology (No.2019YB26), and Cultural and Artistic Creativity Design Institute (No.CACD202003).

REFERENCES

- [1] Agrawal, V., Sharma, D., & Yadav, S. K. (2020). Letter to Editor: “Artificial intelligence, machine learning, deep learning and big data analytics for resource optimization in surgery”. *Indian Journal of Surgery*, 82, 1317–1318. doi: 10.1007/s12262-020-02643-8. Retrieved from <https://europepmc.org/article/MED/33106738>
- [2] Birken, C.S., Lichtblau, B., Lenton-Brym, T. (2015). Parents' perception of stroller use in young children: a qualitative study. *BMC Public Health*, 20 Aug 2015, Retrieved from <https://doi.org/10.1186/s12889-015-1989-6>
- [3] De Onis, M., Onyango, A. W., Borghi, E., Garza, C., Yang, H., & WHO Multicentre Growth Reference Study Group. (2006). Comparison of the World Health Organization (WHO) Child Growth Standards and the National Center for Health Statistics/WHO international growth reference: implications for child health programmes. *Public health nutrition*, 9(7), 942-947.
- [4] Fowler, E., Kobe, C., Roberts, K. J., Collins, C. L., & McKenzie, L. B. (2016). Injuries Associated with strollers and carriers among children in the United States, 1990 to 2010. *Academic pediatrics*, 16(8), 726-733. doi: 10.1016/j.acap.2016.07.002. Retrieved from <https://pubmed.ncbi.nlm.nih.gov/27402353/>
- [5] Frisbee, S. J., & Hennes, H. (2000). Adult-worn child carriers: a potential risk for injury. *Injury prevention*, 6(1), 56-58. doi: 10.1136/ip.6.1.56. Retrieved from <https://europepmc.org/article/med/10728544>
- [6] Hesketh, K. R., Lakshman, R., & van Sluijs, E. M. (2017). Barriers and facilitators to young children's physical activity and sedentary behaviour: a systematic review and synthesis of qualitative literature. *Obesity Reviews*, 18(9), 987-1017. doi:10.1111/obr.12562. Epub 2017 Jun 6. Retrieved from <https://pubmed.ncbi.nlm.nih.gov/28589678/>
- [7] Isaacs, D. (2020). Artificial intelligence in health care. *Journal of Paediatrics and Child Health*, 56(10), 1493-1495 doi: 10.1111/jpc.14828 Retrieved from <https://europepmc.org/article/MED/33099829>
- [8] Kerdlap, P., Gheewala, S. H., & Ramakrishna, S. (2020). To rent or not to rent: A question of circular prams from a life cycle perspective. *Sustainable production and consumption*, 26, 331-342. doi: 10.1016/j.sp.2020.10.008 Retrieved from <https://europepmc.org/article/MED/33072832>
- [9] Ren, M., He, W., Lu, M., & Yu, C. (2017). Intelligent Design of Baby Stroller for Personalization Production Mode. Retrieved from <https://www.researchgate.net/publication/309528631>
- [10] Mireault, G. C., Rainville, B. S., & Laughlin, B. (2018). Push or carry? Pragmatic opportunities for language development in strollers versus backpacks. *Infancy*, 23(4), 616-624. doi: 10.1111/infa.12238. Epub 2018 Apr 16. Retrieved from <https://pubmed.ncbi.nlm.nih.gov/30220884/>
- [11] Powell, E. C., Jovtis, E., & Tanz, R. R. (2002). Incidence and description of stroller-related injuries to children. *Pediatrics*, 110(5), e62-e62. doi: 10.1542/peds.110.5.e62. Retrieved from <https://pubmed.ncbi.nlm.nih.gov/12415068>
- [12] Sehat, A. R., & Nirmal, U. (2017). State of the art baby strollers: Design review and the innovations of an ergonomic baby stroller. *Cogent Engineering*, 4(1), 1333273. Retrieved from <https://doi.org/10.1080/23311916.2017.1333273>
- [13] Tremblay, M. S., LeBlanc, A. G., Carson, V., Choquette, L., Connor Gorber, S., Dillman, C., ... & Kho, M. E. (2012). Canadian sedentary behaviour guidelines for the early years (aged 0–4 years). *Applied Physiology, Nutrition, and Metabolism*, 37(2), 370-380. doi: 10.1139/h2012-019. Retrieved from <https://pubmed.ncbi.nlm.nih.gov/22448609/>
- [14] Wu, C. Y., Huang, H. R., & Wang, M. J. (2017). Baby carriers: a comparison of traditional sling and front-worn, rear-facing harness carriers. *Ergonomics*, 60(1), 111-117. doi: 10.1080/00140139.2016.1168871. Epub 2016 Apr 7. Retrieved from <https://pubmed.ncbi.nlm.nih.gov/27054475/>
- [15] Zhang, D., & Wei, B. (2020). Smart Sensors and Devices in Artificial Intelligence, *Sensors*, 20(20), 5945. doi: 10.3390/s20205945. Retrieved from <https://europepmc.org/article/MED/33096695>

Calm my Headspace: Motivations and Barriers for Adoption and Usage of Meditation Apps during Times of Crisis

(Full Paper)

MacKenzie Kellen, Trinity College Dublin, Ireland, kellenm@tcd.ie

Deepak Saxena*, Trinity College Dublin, Ireland and Birla Institute of Technology & Science Pilani, India, saxenad@tcd.ie

ABSTRACT

Meditation applications for smartphones have been steadily growing in popularity. During the current Coronavirus pandemic, usership of various meditation apps has grown to reach record levels. This study explores the motivations for and barriers to adoption and usage of meditation apps during times of crisis. The study is based on qualitative, semi-structured interviews conducted with seventeen participants. The interviews were audio recorded, transcribed verbatim, and coded using the NVivo software. Inductive thematic analysis identifies five themes: job-related factors, changing lifestyles, psychological conditions and worries, perceived outcomes, and price. All themes except for pricing were found to be motivators for use, while price was deemed a barrier to use. The themes align with the constructs from the Technology Acceptance Model (TAM), the Unified Theory of Acceptance and Use of Technology (UTAUT), and the Diffusion of Innovation (DOI) Theory, providing some useful guidance to meditation app providers.

Keywords: Meditation app, mindfulness app, motivation, barriers, calm, headspace.

*Corresponding author

INTRODUCTION

Meditation is an ancient practice that recently has seen an uptick in popularity in Western countries. This is in part due to the creation of a vast library of dynamic mobile applications (apps) that have transformed traditional meditative processes into accessible courses available at your fingertips. Between 2010 and 2020, record numbers of meditation apps were released in the iOS and Android app stores, with more than 1,500 meditation and mindfulness apps currently available (McGroarty, 2019). One such app, Headspace, launched in 2010, has thirty-five million users in 190 countries and earned \$56 million in revenue in 2019. Similarly, Calm, founded in 2012, reports over twenty-six million users with fifty-thousand new signups each day, and an estimated \$92 million in revenue in 2019 (Williams, 2020). These strong growth figures illustrate the popularity and draw of meditation apps.

In the year 2020, the growth in users of meditation apps has not only continued but also has been intensified by the current Coronavirus pandemic. Meditation and mindfulness app downloads in the iOS app store reached a weekly record of 750,000 during the week of March 29th, a twenty-five percent increase from one-month prior (Lerman, 2020). Increased societal fears, uncertainties, stress and anxiety levels, likely connected to the global spread of the pandemic, served as a catalyst for the jump in meditation app downloads.

This study aims to explore the factors that motivate or turn away millennial-aged individuals from using meditation apps during times of crisis. Specifically, the study addresses the following research question: *What are the motivations and barriers for the use of meditation apps during times of crisis?* In support of this research question, the remainder of the paper is organized as follows. Next section provides theoretical foundation of this study by discussing the benefits of meditation, and user perceptions and motivations for usage of health-related apps. This is followed by a discussion on research methodology employed in this study. Subsequent section outlines the themes identified based on the analysis. Thereafter, the findings are interpreted in light of relevant theories. This is followed by the practical implications of the findings. The concluding section outlines limitations and future work.

LITERATURE REVIEW

Benefits of Meditation

The benefits of meditation have been extensively studied in clinical and non-clinical settings. Meditation has been found to increase concentration and compassion (Baer *et al.*, 2012; Bennike *et al.*, 2017), reduce depression, anxiety and psychological distress (Boettcher *et al.*, 2014; Chen *et al.*, 2012; Grégoire *et al.*, 2015), reduce insomnia (Ong *et al.*, 2008), and increase overall wellbeing (Howells *et al.*, 2016; Ivtzan *et al.*, 2016). Perhaps the most relevant to the current Coronavirus pandemic are meditation's potential benefits on patients' immune systems and in stress reduction and patient outcomes for healthcare professionals. Davidson *et al.* (2003) report significant increases in antibody responses to influenza vaccine among subjects who participated in an eight-week meditation training program compared to a control group. Grepmaier *et al.* (2007) find that psychotherapists practicing Zen meditation had significantly higher therapeutic evaluations. Shapiro *et al.* (2005) support the efficacy of an eight-week meditation program in reducing stress and increasing self-compassion among healthcare

professionals. As the Coronavirus pandemic crisis continues to circulate around the globe, hospital workers and healthcare professionals are reporting symptoms of burnout and stress at record levels. Meditation or mindfulness training may be helpful in alleviating the dangerous psychological burden that has been placed on medical workers through this pandemic.

Meditation Apps

It is important to address the prior research done on mobile health and electronic health initiatives in order to contextualize the industry in which meditation apps have been released. Internet-based mindfulness treatment programs have been found to improve concentration (Bennike *et al.*, 2017) and decrease anxiety symptoms (Boettcher *et al.*, 2014). A meta-analysis by Portnoy *et al.* (2008) finds that Internet-delivered health interventions can treat a range of behaviors such as tobacco and substance use, and bingeing/purging episodes. Interestingly, remote delivery (Internet or mobile phone) of a mindfulness intervention does not seem to lessen its efficacy (Boettcher *et al.*, 2014). Wahbeh *et al.* (2014) examined preferences for the delivery of mindfulness meditation training and reported nearly half of all participants preferred the Internet format as their first choice, for reasons including convenience, privacy, and scheduling flexibility.

Studies have found that mobile apps are effective delivery mediums for mindfulness training. Morris *et al.* (2010) note that mobile apps can deliver psychotherapy and mental health interventions in a non-stigmatizing fashion to people who might not otherwise have accessed the therapy. Kazdin and Rabitt (2013) argue that mobile apps have the potential for success because of their reach, scalability, affordability, and flexibility. They are especially attractive with younger population since they often associate and express their identity with mobile devices (Longo & Saxena, 2020). Studies conducted with adolescents suggest that they find mobile phone delivery format relevant, familiar, and accessible (Chan *et al.*, 2017; Matthews & Doherty, 2011).

While many studies have been conducted on the efficacy of meditation practices, relatively less research is done on the motivators and barriers for the adoption and use of meditation apps. Laurie and Blandford (2016) report that enabling factors to use mobile meditation apps are positive attitudes towards mindfulness, realistic expectations, and positive social influences; barriers to use are busy lifestyles, lack of routine, and negative perception of mindfulness. Peng *et al.* (2016) find that the most common motivators to use health apps are social competition, intangible and tangible rewards, internal dedication and motivation. At the same time, some barriers to adoption are low awareness, lack of need, lack of app literacy, and cost. While other studies were conducted during normal times, this study seeks to investigate these factors during a time of crisis, using Coronavirus pandemic as a context.

METHODOLOGY

Since the research question (*what are the motivations and barriers for use of meditation apps during times of crisis?*) is exploratory in nature, an interpretive research approach was deemed necessary to identify themes, relationships, and patterns within the qualitative data. Twenty-three participants were recruited via Instagram Story posted by the first author on her personal Instagram account in May 2020. The Instagram Story asked if any followers have used meditation apps during quarantine, and, if so, requested them to contact the author to participate in the study. The compensation for participation was entry into a raffle to win a \$100 Amazon gift card. Since the study focused on motivations for adoption and usage of meditation apps during times of crisis, the inclusion criterion was that participants must have used a meditation app at least five times during quarantine. Of the twenty-three participants who were initially recruited, six did not meet the inclusion criterion, so the final number of participants was seventeen. These participants differ from those in previous studies in that they were specifically recruited as preexisting users of meditation apps, as opposed to participants who were asked to use a meditation app for the purpose of the study. The participants' ages ranged from twenty to twenty-seven. Of the seventeen participants, thirteen were female and four were male. Except for one French participant located in France, the rest were American citizens living in the USA. Fourteen participants were college graduates who had been employed in full-time jobs, and three were still attending college.

All interviews were one-on-one, in-depth, and semi-structured in nature. The interviews started with basic questions about participants' experiences with health apps and meditation in general, and moved to more focused, sensitive questions at the end, such as questions regarding participants' personal experiences during quarantine and any emotions that were felt during that time. Both authors have used meditation apps for many years prior to the current study, and during the research design phase, engaged in an autoethnography to frame the questions that would probe participant motivations. Pre-structured interview topics included: previous experience with health apps, previous experience with meditation or mindfulness training, meditation apps that have been used in the past or currently use, patterns of usage with meditation apps, and personal experience during quarantine/lockdown. Because of the exploratory nature of the study, the questions were positioned as open-ended as possible in order to delve into *why* and *how* participants chose and subsequently used certain meditation apps. To retain a natural setting, no specific apps were recommended for the study and the participants used the apps they preferred. Table 1 shows the list of meditation apps used by participants, in order of their prevalence. Mimicking the observations from Williams (2020), Headspace and Calm remain two most popular choices.

Table 1: Meditation apps used by the participants.

App	Usage among participants	Used for
Headspace	11	Anxiety & stress management, focus, mindfulness
Calm	9	Sleep, focus, stress management
Peloton	2	Focus, mindfulness, anxiety management
Relax Melodies	2	Sleep, stress management
Waking Up	2	Philosophical guidance, stress & anxiety management
YouTube	2	Mindfulness
Balance	1	Focus
Meditopia	1	Focus, mindfulness
Soul Time	1	Spiritual guidance, mindfulness
Spotify	1	Stress & anxiety management

With health and safety considerations in mind during Coronavirus crisis, interviews were conducted over mobile phone. The first few minutes of each call were spent making casual talk in order to build rapport with the interviewee. The interviewer then described the purpose of the study, the topics that the interview would cover, and briefly talked about her own experience with meditation and meditation apps in order to build trust. The participants were encouraged to speak openly and honestly. Probing questions were also asked to follow up on any insights generated from the main set of questions. While each interview was recorded, notes were also taken to support the data collection process.

The audio recordings of the interviews were uploaded to NVivo for transcription and analysis. To avoid the occasional errors made by the software, each transcript was carefully read to correct the errors as part of data cleaning. While reading through each transcript, various notes, annotations, and memos were added to keep track of trends and themes that were becoming apparent. In the initial open coding, key primary themes emerged based on the number of occurrences within the data. Thereafter, axial coding was conducted in which subthemes were identified along with the relationships between themes and categories of data. Throughout the coding process, data extracts were constantly reorganized and rearranged to fit new themes and hierarchies that became apparent. Results of the thematic analysis are presented in the next section.

ANALYSIS AND FINDINGS

Figure 1 shows the major themes identified in the study, which are job-related factors, changing lifestyles, perceived outcomes, psychological conditions and worries, and price.

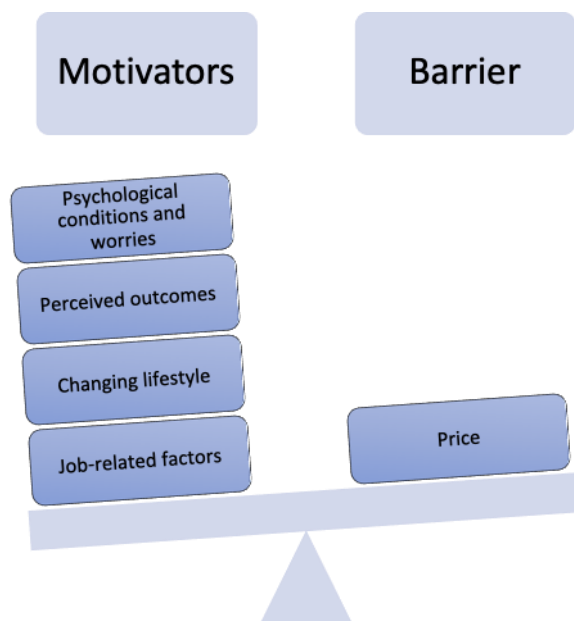

Figure 1: Motivator and Barriers of using meditation apps during a crisis.

Job-related Factors

At the time of the interviews, fourteen participants were working full-time or had been previously employed in a full-time position when the Coronavirus pandemic began. Motivators associated with job-related factors include subscription subsidized by employer, work stress, and layoffs.

Subscription subsidized by employer

Five participants had free access to an annual subscription to a meditation app that was subsidized by their employer. For these participants, the subscription was offered either by the employer directly, or through the health insurance provider. These participants noted that having access to a yearly subscription, free of charge, was a motivator for trying out the app, though not all of them remained consistent with their usage. As one participant notes:

I think if it wasn't being paid for, I might have downloaded and subscribed for a month, just to see what it's about. Definitely as long as it's supplied to me, I will absolutely continue to use it.

Some stated that because they were able to try out a subscription for free, they would be more likely to pay for a subscription themselves in the future. Of those who tried out the free subscription but did not continue, some acknowledged that they fell out of a routine with meditation altogether, while another stated that he had previously purchased a subscription to a different app that he liked more than the one offered by his employer. Regardless, of the five who had access to a subsidized annual subscription to an app, all had tried the app at least once. One participant describes the relationship between her employer-subsidized subscription and the increased stress that she and her coworkers felt during the early days of the pandemic:

I think it [the app subscription] definitely was in direct response to the pandemic. They [the HR department] understand it's been a more stressful time lately.

Many participants discussed utilizing their subsidized meditation app subscriptions to mitigate work-related stressors, which is discussed next.

Work stress

Work stress was discussed by many participants. Some worked in, or adjacent to, sectors and industries that had been negatively impacted by the pandemic, including hospitality, health, and airlines. In some cases, the participants in these sectors described how their client portfolios vanished 'overnight' and their subsequent scrambles to find business for their firms. Others discussed the long hours they worked as their jobs became busier with pandemic-related business, describing the expectations to be 'on call' at all times. In all cases of work-related stress, participants described this stress as manifesting in anxiety during daytime, or sleeplessness at night. These by-products of work-related stress were motivators for many participants to pursue meditation as a form of stress relief. Several other participants acknowledged that they used meditation as a break during the daytime, a respite from busy schedules and work stressors. One participant stated that if he felt stressed or anxious during work, he knew he could turn on a meditation and "chill out after that and get back to work and be more productive". Interestingly, one participant described how her meditation app usage dropped to zero during quarantine since the demands of her job increased and she became busier than ever before. However, she acknowledged that her history with meditation prior to the pandemic allowed her to become 'more aware' of fluctuations in her mental states and stress levels, noting that "I didn't necessarily meditate, but through different means I guess I was still able to do some form of self-care". This was only one of three instances in which a participant's meditation app usage dropped to zero, rather than increasing during quarantine.

Layoffs

Company layoffs was a theme that came up in several interviews. Participants described the stress and unease of layoffs occurring within their companies, seeing coworkers lose their jobs, and not knowing their own fates. Some participants, who were already laid off, discussed the difficulties they suddenly faced as being unemployed during the pandemic. Two participants said that losing their jobs in the beginning of the pandemic was the catalyst that spurred them to try a meditation app. As one participant describes:

I was laid off due to COVID, and I was feeling stressed out and felt like I needed to clear my mind. I had a lot of thoughts that were running through my head, about what I needed to be doing, you know, next steps, and to ease that, I looked into these apps. I think what triggered it was definitely losing my job.

Others spoke about the stress of watching coworkers being laid off and let go. One participant described constantly 'feeling scared', as his company had gone through several rounds of layoffs:

The pressure of my work performance, this crisis and how all of that could impact my performance, those were the main reasons I looked to meditation on a daily basis.

This participant acknowledged that he was uncertain about the future of his employment, but meditation helped to calm his uneasy thoughts.

Changing Lifestyles

As societies and communities around the world are making adjustments on a macro scale to accommodate the newfound risks of the Coronavirus, individuals are making adjustments at the micro level. Pre-pandemic lifestyles and routines have changed in countless ways as workers stopped going into their offices, businesses shuttered, and travel ground to a halt. Many participants discussed how they adjusted to this 'new normal' and how these changes affected their meditation practices. Subthemes that were noted within lifestyle changes include changes to living arrangements and restrictions on otherwise normal activities.

Changes to living arrangements

Changes in the living arrangements of participants were noted frequently during the interviews. Many talked about moving back home with their parents, either for a period of time during quarantine, or permanently. Participants who moved home permanently did so for a variety of reasons – to be with family during challenging times, lack of space for home office, or not

being able to afford rents. Participants described facing a loss of independence as they shared their personal spaces and altered their routines to fit into the homes of their parents. The majority who moved home stated that they increased their usage of meditation apps to cope with parental restrictions and living in a space that was not their own. One participant described how her mother's Coronavirus fears affected her while at home:

My mom is really intense about quarantining. She doesn't want me to see anyone, so I've been pretty isolated since February, super early in the pandemic. Meditation is what helps me break up the monotony, the isolation, and helps me have a routine.

In contrast, one participant stayed in his apartment throughout the initial quarantine period in his city and described the isolation and loneliness he felt as his roommates left to move back home with their families:

I just had a general feeling of both of my roommates being gone, and feeling a little down, feeling a little stressed out with work, and I was like, 'Okay, I'm not feeling as good as I would like to, and what can I do to improve that?'

He remembered what he had heard from friends over the years, attesting to the positive benefits of meditation, and said it was a combination of these two things (a suddenly altered living arrangement and recommendations from friends) that motivated him to try a meditation app during quarantine.

Restrictions on otherwise normal activities

A number of participants discussed changes to their lifestyles in the form of closures of offices, restaurants, bars, gyms, and yoga studios. These participants addressed the sudden void they felt as their "normal activities were taken away" as a result of the closure of these public spaces. Office closures and subsequently working from home came up in the interviews of every participant who was employed in a full-time position. Many said that they missed the social interactions of an office. One participant notes:

I'm used to working around a lot of coworkers in our office, and just having a more social setting. It's been a big adjustment working from home.

As the boundaries between working space and living space blurred, many participants turned to meditation to "break up the day" and create a routine during a time when normal routines were disrupted. Participants also discussed the boredom and excessive free time they faced as social spaces like bars, restaurants, gyms, and yoga studios closed due to pandemic restrictions. For many, this free time, coupled with being restricted to one's living space, encouraged meditation. As one participant describes:

I had so little going on with quarantine, and I was open to doing whatever I could to have new experiences. I had time on my hands, and I was happy to try something new and do something different.

Another participant spoke about how, with the absence of regular in-person yoga classes, she needed a new activity to create the same "mental feeling" that a yoga class provided:

Prior to COVID, I was lacking with my meditation, because I was going to yoga and grouping it all in the same category. And then when I couldn't go to yoga anymore, that's when I started meditating a lot more. Since COVID, I've got a lot more free time on my hands, as I think we all do, and it's forced me to look inwards.

Those who looked to meditation to fill a gap created by the absence of normal social activities reported varying results. Many discussed a sense of accomplishment they felt after meditating for multiple days in a row, while others stated that meditation seemed to make no difference on how they perceived their boredom and free time. Interestingly one participant reported her meditation app usage being dropped to zero throughout the entire quarantine period in her city because she "felt like [she] had nothing to meditate on. Nothing was happening". She felt that she would start meditating more regularly once quarantine restrictions lifted, as regular meditation had seemed to reduce her stress levels prior to the pandemic.

Psychological Conditions and Worries

Another set common motivators were psychological conditions and worries that had either been pre-existing or resulting from the pandemic. Anxiety, stress, and insomnia were frequently discussed during interviews, and are presented here as subthemes.

Anxiety

Symptoms of anxiety were mentioned by thirteen participants. Of those, several participants began using meditation apps prior to the pandemic because they were looking to calm anxiety symptoms. "When I went to college, I started to get some anxiety, and meditating totally helped with that", one participant notes. Two participants had meditation apps recommended to them by their respective therapists years ago. It is interesting to note that in both cases, these participants were initially against the advice of their therapists but acknowledged that they felt more motivated to meditate during the pandemic, as their anxiety levels had risen. Several other participants discussed using meditation apps in conjunction with therapy, medication or exercise. Two participants discussed creating a meditation practice to replace or work in tandem with their anxiety medications, with one noting:

As you decrease trying to medicate certain issues, there's a lot of behavioral therapy you can incorporate, and meditation has been pretty high up on the list of recommended ways to deal with general feelings of anxiety, outside of medication.

The combination of the therapy and meditation came up frequently during interviews; several participants talked about either currently seeing a therapist in addition to their meditation practice or expressing a desire to start seeing a therapist in addition to meditation. Others who may not have experienced symptoms of anxiety prior to the pandemic discussed feeling anxious during quarantine, and this was a motivator for them to try meditation. One participant recalls:

There was so much fear and anxiety, especially in March and April [2020], I needed to do something to take my mind off of the news.

Many spoke about how their anxiety levels had seemed to fluctuate over the course of the initial quarantine period, and their meditation app usage correlated with these fluctuations. One participant notes:

I don't have diagnosed anxiety or anything, but I noticed when I would feel more anxious and stressed, I definitely use the apps more.

Many participants who had tried meditation apps for managing anxiety reported perceiving a reduction in the strength and frequency of symptoms, even if it was temporary for some.

Stress

Many participants turned to meditation to manage rising stress levels they felt had resulted due to the pandemic. In addition to the previously discussed job stress among participants, some reported feeling a constant level of general stress throughout the beginning of the Coronavirus outbreak and quarantine. One participant spoke about the difference between her stress management abilities prior to using an app, compared to now:

Before, in high school and early in college, I would get so overwhelmed and freaked out that I would cry. Now, I'm able to look at myself and say, 'You need to calm down.' I'm more aware of myself now.

Even if some participants did not turn to meditation apps specifically to handle stress, the majority reported using meditations for stress at least once. Several participants acknowledged that they had become motivated to meditate not just during "the bad times," but in future post-pandemic life as well, in order to manage stress once normal ways of life resume. One participant observes:

I want to use it all the time now, even when I'm not stressed, because the benefit of it comes out when you are so in that habit, and something that might normally make you upset, doesn't anymore.

Others echo this sentiment about using meditation in the future to maintain positive coping mechanisms for difficult emotions. Many participants felt there was overlap or a correlation between their stress levels and not being able to sleep at night. This is discussed in the next subtheme.

Insomnia

A majority of participants turned to meditation apps to aid in sleeplessness and insomnia. As with the previous two subthemes, some participants acknowledged sleeping troubles that had existed prior to the pandemic, while others felt that sleeplessness was a new phenomenon that arose during the Coronavirus outbreak. One participant recalls:

I felt like my personal experience with stress, especially during quarantine, most definitely manifests in me having difficulty sleeping. I definitely get the most use out of the sleep features.

Others looked to meditation as a drug-free alternative to sleep aids like melatonin, and many reported falling asleep faster and feeling like they had gotten 'better' sleep on the nights they meditated. Many who used the Calm app talked about a feature called Sleep Stories, in which celebrities, athletes, and figures in popular culture read bedtime stories that are to be listened to in place of a meditation. This function was well-received by participants who had used Calm, and was a motivator in itself for some:

I kind of felt like I had gone through all of Headspace's programming by the time I stumbled upon Calm. And I wanted to hear someone else's voice besides the Headspace narrator. That's why I like Calm, is the variety of narrators, and the longer bedtime stories when I can't sleep.

Although the Sleep Stories were not designed as meditations, participants who used them reported similar feelings of calm, relaxation, and fewer intrusive thoughts. Nearly all the apps used by participants incorporate a sleep category into their functionality, however, Calm is the only app utilizing celebrity voices in its meditations.

Perceived Outcomes

Many participants were motivated to use meditation apps because they were aware of the potential benefits of meditation. There was a range of positive results and benefits that participants perceived to be possible from meditation. As discussed in the previous theme, a number of participants hoped to mitigate symptoms of psychological conditions and worries like anxiety, stress, and insomnia. Some wanted to be 'more mindful' in their daily routines:

It was honestly something that I read about, having a morning routine and starting your day without thinking of your to-do list, but being mindful and present. I think being mindful helps with overwhelm in general, and it's hard to feel overwhelmed if you're taking things one day at a time. This helps me focus on a few small things that I can control.

Other participants felt that meditation would help them become less distracted and more focused. "I wanted to try it so I could improve my concentration", one participant notes. Some felt that meditation would help them filter out the distractions of modern life, like social media, text messages, emails, and phone calls:

I was noticing how I was plugged in constantly and I was trying to focus on multiple things at once, and I wanted to have a part of my day where I could be alone with my thoughts.

Productivity was another perceived benefit to be gained from meditation:

I thought it would help organize my thoughts, like make me more productive. I wanted to slow down to then feel like I could complete my tasks in a better way.

Several other participants discussed their hope to become more self-reflective through regular meditation. "I guess I wanted a ritual of sorts to unwind and reflect on the day and practice more gratefulness", one stated. When prompted about their initial

learning of these potential benefits, some participants felt that the apps' marketing and advertising had contributed to their beliefs about the benefits, while others acknowledged that it was simply general knowledge they had accumulated or been exposed to over the years. For some, it was through recommendations by friends and coworkers. Other participants referenced specific anecdotal evidence they had received about the benefits of meditation that motivated them to try out an app. One participant adds:

I know some pretty high-powered businesspeople that are super into meditation, and they make time for it every single day, even when they're in the office. They rave about the benefits, and I felt like it was almost a trait of successful people, that they meditate.

Price

Most meditation apps follow a freemium pricing model, offering free trial periods and/or some basic functionality to entice users into paying for subscription. Participants took full advantage of these free periods by trying out different apps. When the trial periods ended, participants were forced into choosing one app to subscribe to. One participant recalls:

I was using the free trials of both Calm and Headspace, and when they ended, I felt like I could still get value out of Calm for free, but with Headspace they had barely any free content, which is why I chose to pay for it.

Price was identified as a barrier as the monthly subscription cost of some apps discouraged many participants. Interestingly, this also motivated the participants to seek other free options. Some looked for free content on streaming platforms like Spotify and YouTube: "I decided I didn't want to pay for any apps, because there is plenty of free content out there in the universe". Some participants acknowledged that their app usage tapered off or stopped around the time that the free trials ran out: "I was going to pay for a subscription, and then I didn't, and that's about when my usership dropped off". Many described their reluctance to pay for an entire year-long subscription, as they weren't sure if they would end up using the app consistently. "At the time, I wasn't sure I wanted to pay seventy-five dollars for something I wasn't sure that I would use", one said. Several participants who had been laid off during the pandemic expressed motivations to find free meditation content, as their financial status did not allow them to pay for a year-long subscription up-front. Overall, sentiments about the prices of different apps were negative; even those who paid for an annual subscription said they wished the prices were lower or that there was an app "that had everything for free".

INTERPRETING THE FINDINGS

Since the benefits of meditation are already established in the wellbeing literature (e.g., Baer *et al.*, 2012; Bennike *et al.*, 2017; Boettcher *et al.*, 2014; Chen *et al.*, 2012; Grégoire *et al.*, 2015; Howells *et al.*, 2016; Ivztan *et al.*, 2016; Ong *et al.*, 2008), in this section the findings are revisited from an interdisciplinary perspective. The findings closely relate to three theories that are widely used to explain technology acceptance, adoption, and usage: The Technology Acceptance Model (TAM), the Unified Theory of Acceptance and Use of Technology (UTAUT), and the Diffusion of Innovation (DOI) Theory.

Technology Acceptance Model

Two constructs from TAM, perceived ease of use and perceived usefulness (Lee *et al.*, 2003) clearly map to the findings of this study. The perceived usefulness construct, which measures a technology's value to an individual, can explain why so many participants were motivated to use a meditation app for the perceived benefits they believed to be possible. In TAM, perceived usefulness and perceived ease of use are found to be sufficient enough to predict the use of a system (Chuttur, 2009). Nearly all participants, when asked what they would change about the meditation apps they had used, reported no desired changes to the design and user experience of the apps. This demonstrates strong perceived ease of use among most participants, which, when coupled with perceived benefits as a main motivator, can explain their motivations. This outcome falls in line with the results from Peng *et al.* (2016), in which perceived usefulness was mapped to participant sentiments about needing health apps to establish healthy habits. The theme of perceived benefits from the current study also falls in line with the results from Laurie & Blandford (2016), in which perceived consequences of using the app was a facilitator for use of Headspace. Additionally, this finding reflects similar outcomes as Ahtinen *et al.* (2013), in which perceived benefits was found to be a primary motivator for use of a mindfulness training app.

Unified Theory of Acceptance and Usage of Technology

A number of constructs from UTAUT can be mapped to a number of themes from the current study. Facilitating conditions, which refers to an individual's perceptions of the resources and support available for technology use (Venkatesh *et al.*, 2012), describes why so many participants were motivated to use a meditation app because it had been subsidized by their employers. Interestingly, Peng *et al.* (2016) map the facilitating conditions construct to their finding that a lack of app literacy hinders health app use. This result demonstrates how poor facilitating conditions can lower motivations for use. The price value construct can explain why some participants were motivated towards certain apps due to price and turned away from others. Price value is consumers' cognitive tradeoff between the monetary cost for using the app and perceived benefits of the applications (Venkatesh *et al.*, 2012). Participants had differing opinions and beliefs of the perceived benefits of meditation apps. Some were more likely to pay for an annual app subscription, while others may have felt that the monetary cost was greater than the perceived benefits. This falls in line Peng *et al.* (2016), who report app cost as a hindering factor for health app use. Another UTAUT construct, hedonic motivation, can explain why participants turned to meditation apps in lieu of normal activities that had been shut down due to the pandemic. Hedonic motivation refers to the satisfaction or pleasure derived from using the technology (Venkatesh *et al.*, 2012). Those who suddenly found themselves lacking enjoyable, pleasure-inducing activities as a result of quarantine restrictions were likely more motivated to find replacements, and saw meditation apps as a

suitable, temporary yet novel alternative. Peng *et al.* (2016) find hedonic motivation to be a primary motivating theme, particularly for the younger generation. This finding is particularly relevant as the current study examined a population in the millennial age group.

Diffusion of Innovation Theory

DOI focuses on the way and means by which an innovation is disseminated (Chang, 2010). Through social channels, the novelty of an innovation is communicated, and its use becomes more widespread. Innovation characteristics, a construct within DOI, is particularly relevant to the current study, as it explains why some technologies become successful, while others never become popular (Kaminski, 2011). One such characteristic of innovation is compatibility, referring to the degree to which the innovation is perceived to be consistent with perceived needs and socio-cultural values (Kaminski, 2011), which can explain why changes to living arrangements was a motivation for use. Meditation apps may have not fit into participants' pre-pandemic needs, but once lifestyles began to change as participants moved in with their parents or lost roommates, meditation apps became compatible with perceived needs. Changes to living arrangements support the findings that context of use may facilitate or hinder meditation app use (Laurie & Blandford, 2016). Observability, another construct within DOI, can be mapped to the theme of psychological conditions and worries. Observability refers to the degree to which the benefits of an innovation are apparent to potential adopters (Kaminski, 2011). Many participants who used meditation apps to manage symptoms of anxiety, stress, and insomnia did so because of recommendations from other users, or because of anecdotal evidence and general knowledge of the benefits. The results of meditation apps in managing these conditions were visible to participants prior to adoption, which was a primary motivator for many.

PRACTICAL IMPLICATIONS

The constructs discussed in the previous section provide useful guidelines for the development of successful apps. Perceived benefits and observability of using a meditation app are a motivation for many participants. Thus, developers and marketers must seek to highlight these two constructs in order to adequately motivate users. While the design of the app needs to be more intuitive, the benefits should be observable to users (for instance, via user logs and weekly reports). The expectations of users in terms of perceived value must be met, otherwise usership will likely drop once the free trial period ends.

Facilitating conditions is another important construct that can be leveraged to promote usership. For some participants, having access to a subsidized annual subscription was the only motivation they needed to try the app. Of those who did not continue with usage, facilitating conditions can be further developed to promote user retention. For example, two participants reported a culture of mindfulness within their work environments, prior to the pandemic, with weekly scheduled meditation sessions and specific meditation rooms within their offices. These strong facilitating conditions had encouraged these participants to use their subsidized app subscriptions, and, over time, they had become more habitual users. Meditation app providers can promote stronger facilitating conditions through sponsored meditation sessions at work and via tie-up with mental health professionals. Employers can offer multiple app subscriptions to employees in order to cater to different individual needs.

Price was the only barrier to use that was discussed by several participants. Many expressed a desire for lower annual subscription prices, or subscriptions available on a monthly basis. Other participants expressed a desire for more health insurance companies to offer subsidized app subscriptions. Meditation app companies should take these suggestions into consideration when determining the pricing and subscription tiers. Interestingly, one participant even compared meditation apps with social services:

It would be interesting to see if this could be provided to more people as a social service, you know? I feel like if it helps mental health and overall health, then it's something that could ultimately drive down healthcare costs.

In light of the current Coronavirus pandemic, this sentiment is important. Millions of people across the world have lost their jobs due to the economic fallout of the pandemic, and the option to pay for an annual subscription to an app is now unattainable for many. Furthermore, levels of anxiety, depression, and stress are skyrocketing as healthcare systems become overburdened to their breaking points. Hence, policymakers may consider providing meditation apps as a social service to ensure wellbeing with justice (Krishnakumar & Nogales, 2015). Headspace has taken a lead in this regard by offering free premium subscription to the healthcare workers and those who lost jobs during the Coronavirus pandemic.

CONTRIBUTION, LIMITATIONS & FUTURE WORK

The current study contributes to the literature in a number of ways. First, pre-existing users of meditation apps were recruited for the study to explore their motivations in a natural way. The participants were not asked to use an app specifically for the study, and because of this, the motivations and barriers for use that this study has captured reflect entirely personal, real-time decisions. Second, the study was conducted in the context of a global crisis, the current Coronavirus pandemic. The themes that were found to be motivations for use are job-related factors, changing lifestyles, psychological conditions and worries, and perceived outcomes, while price is the only theme that is both a motivator and barrier to use.

Certain limitations of this study are to be noted. The current study explores motivations in a population of millennial-aged educated individuals. Because of this, results cannot be generalized to the general population, especially older generations and less-educated individuals. Future studies can improve on this by recruiting a diverse population with a range of ages, occupations, socioeconomic statuses, and levels of education. Because of the nature of the study, participants were asked to

recall their experiences with meditation apps, potentially creating recall biases as they answered questions relating to their experiences. However, to counter this limitation, the researchers sought to limit recall bias by asking non-leading questions.

As the current study aims to explore motivations for and barriers to usage of meditation apps *during* times of crisis, it is impossible to predict if participants will continue to use meditation apps *after* the pandemic has subsided. In order for app developers and marketers to gauge long-term usage patterns through crises such as the Coronavirus pandemic, future studies may incorporate longitudinal research methods to examine motivations for usage in the post-pandemic society.

REFERENCES

- [1] Ahtinen, A., Mattila, E., Välikkynen, P., Kaipainen, K., Vanhala, T., Ermes, M., ... & Lappalainen, R. (2013). Mobile mental wellness training for stress management: feasibility and design implications based on a one-month field study. *JMIR mHealth and uHealth*, 1(2), e11.
- [2] Baer, R. A., Lykins, E. L., & Peters, J. R. (2012). Mindfulness and self-compassion as predictors of psychological wellbeing in long-term meditators and matched nonmeditators. *The Journal of Positive Psychology*, 7(3), 230-238.
- [3] Bennike, I. H., Wieghorst, A., & Kirk, U. (2017). Online-based mindfulness training reduces behavioral markers of mind wandering. *Journal of Cognitive Enhancement*, 1(2), 172-181.
- [4] Boettcher, J., Åström, V., Pålsson, D., Schenström, O., Andersson, G., & Carlbring, P. (2014). Internet-based mindfulness treatment for anxiety disorders: a randomized controlled trial. *Behavior therapy*, 45(2), 241-253.
- [5] Chan, A., Kow, R., & Cheng, J. K. (2017). Adolescents' perceptions on smartphone applications (apps) for health management. *Journal of mobile technology in medicine*, 6(2), 47-55.
- [6] Chang, H. C. (2010). A new perspective on Twitter hashtag use: Diffusion of innovation theory. *Proceedings of the American Society for Information Science and Technology*, 47(1), 1-4.
- [7] Chen, K. W., Berger, C. C., Manheimer, E., Forde, D., Magidson, J., Dachman, L., & Lejuez, C. W. (2012). Meditative therapies for reducing anxiety: A systematic review and meta-analysis of randomized controlled trials. *Depression and anxiety*, 29(7), 545-562.
- [8] Chuttur, M. Y. (2009). Overview of the technology acceptance model: Origins, developments and future directions. *Working Papers on Information Systems*, 9(37), 9-37.
- [9] Davidson, R. J., Kabat-Zinn, J., Schumacher, J., Rosenkranz, M., Muller, D., Santorelli, S. F., Sheridan, J. F. (2003). Alterations in brain and immune function produced by mindfulness meditation. *Psychosomatic Medicine*, 65(4), 564-570.
- [10] Grégoire, S., Lachance, L., & Taylor, G. (2015). Mindfulness, mental health and emotion regulation among workers. *International Journal of Wellbeing*, 5(4), 96-119.
- [11] Grepmaier, L., Mitterlehner, F., Loew, T., Bachler, E., Rother, W., Nickel, M. (2007). Promoting mindfulness in psychotherapists in training influences the treatment results of their patients: A randomized, double-blind, controlled study. *Psychotherapy and Psychosomatics*, 76(6), 332-338.
- [12] Howells, A., Ivtzan, I., & Eiroa-Orosa, F. J. (2016). Putting the 'app' in happiness: a randomised controlled trial of a smartphone-based mindfulness intervention to enhance wellbeing. *Journal of Happiness Studies*, 17(1), 163-185.
- [13] Ivtzan, I., Niemiec, R. M., & Briscoe, C. (2016). A study investigating the effects of Mindfulness-Based Strengths Practice (MBSP) on wellbeing. *International Journal of Wellbeing*, 6(2), 1-13.
- [14] Kaminski, J. (2011). Diffusion of innovation theory. *Canadian Journal of Nursing Informatics*, 6(2), 1-6.
- [15] Kazdin, A. E., & Rabbitt, S. M. (2013). Novel models for delivering mental health services and reducing the burdens of mental illness. *Clinical Psychological Science*, 1(2), 170-191.
- [16] Krishnakumar, J., & Nogales, R. (2015). Public policies for wellbeing with justice: A theoretical discussion based on capabilities and opportunities. *International Journal of Wellbeing*, 5(3), 44-62.
- [17] Laurie, J., & Blandford, A. (2016). Making time for mindfulness. *International journal of medical informatics*, 96, 38-50.
- [18] Lee, Y., Kozar, K. A., & Larsen, K. R. (2003). The technology acceptance model: Past, present, and future. *Communications of the Association for information systems*, 12(1), 50 752-780.
- [19] Lerman, R. (2020, April 21). Feeling stressed? Meditation apps see surge in group relaxation. *Washington Post*. <https://www.washingtonpost.com/technology/2020/04/21/meditation-up-during-coronavirus/>
- [20] Longo, I. & Saxena, D. (2020, October). Self-brand connection in the digital age: a qualitative exploration of brand usage on instagram for identity creation among millennials. In Proceedings of *The 20th Portuguese Association for Information Systems Conference*, Universidade Portucalense, Porto, Portugal.
- [21] Matthews, M., & Doherty, G. (2011). *In the mood: engaging teenagers in psychotherapy using mobile phones*. In Proceedings of the SIGCHI Conference on Human Factors in Computing Systems (pp. 2947-2956). ACM.
- [22] McGroarty, B. (2019). *2019 Global Wellness Trends Report: Meditation Goes Plural*. Global Wellness Institute. <https://www.globalwellnesssummit.com/2019-global-wellness-trends/download-report/>.
- [23] Morris, M. E., Kathawala, Q., Leen, T. K., Gorenstein, E. E., Guilak, F., DeLeeuw, W., & Labhard, M. (2010). Mobile therapy: case study evaluations of a cell phone application for emotional self-awareness. *Journal of medical Internet research*, 12(2), e10.
- [24] Ong, J. C., Shapiro, S. L., & Manber, R. (2008). Combining mindfulness meditation with cognitive-behavior therapy for insomnia: a treatment-development study. *Behavior therapy*, 39(2), 171-182.
- [25] Peng, W., Kanthawala, S., Yuan, S., & Hussain, S. A. (2016). A qualitative study of user perceptions of mobile health apps. *BMC Public Health*, 16(1), 1-11.

- [26] Portnoy, D. B., Scott-Sheldon, L. A., Johnson, B. T., & Carey, M. P. (2008). Computer-delivered interventions for health promotion and behavioral risk reduction: A meta-analysis of 75 randomized controlled trials, 1988–2007. *Preventive medicine*, 47(1), 3-16.
- [27] Shapiro, S. L., Astin, J. A., Bishop, S. R., & Cordova, M. (2005). Mindfulness-based stress reduction for health care professionals: results from a randomized trial. *International journal of stress management*, 12(2), 164-176.
- [28] Venkatesh, V., Thong, J. Y., & Xu, X. (2012). Consumer acceptance and use of information technology: extending the unified theory of acceptance and use of technology. *MIS quarterly*, 36(1), 157-178.
- [29] Wahbeh, H., Svalina, M. N., & Oken, B. S. (2014). Group, one-on-one, or internet? Preferences for mindfulness meditation delivery format and their predictors. *Open medicine journal*, 1(1), 66-74.
- [30] Williams, K. (2020, January 31). *Mobile Users Spent \$195 Million in Meditation Apps Last Year, Up 52% Over 2018*. Sensor Tower. <https://sensortower.com/blog/meditation-apps-2019-revenue-downloads>.

Collaborative Platform Empowerment: Case Study in the Digital Transformation of the Interior Design Industry

(Full Paper)

Chia-Yu Jih*, National Chengchi University, Taiwan, 107356503@nccu.edu.tw

Wei-Hsi Hung, National Chengchi University, Taiwan, fhung@nccu.edu.tw

ABSTRACT

As the applications of digital technology matures, how to implement digital services and project management capabilities for interior design companies has become an important topic. This research is conducted with a case study method that solves the pain points of designers by introducing a digital empowerment platform as a collaborative service solution for designers. The research results show that the establishment of the platform for cross-industry collaborative mechanisms will reduce the construction period and internal management costs indirectly drive the overall operating efficiency of the interior design industry.

Keywords: Digital transformation, platform, platform empowerment, interior design industry

*Corresponding author

INTRODUCTION

The rapid development of digital technology has impacted all walks of life, and the company's management rethinks how to make internal innovations in response to the external market environment. In the long run, the strategic goals of these digital transformation are all hoping to increase the company's value creation (Chanias & Hess, 2016). The interior design market has been around for a long time. The Ministry of the Interior has registered 11,090 of the national interior decoration industry, with a total of 26,088 professional and technical personnel. Its composition structure is mostly small and medium-sized enterprises and micro-firms, and the annual output value of the industry has reached NT\$130 billion. This year the world has been affected by the COVID-19 pandemic and the continuation of the China-US trade war, which has driven many Taiwanese businessmen from all over the world to return to Taiwan. As a result, the demand for buying new houses and rebuilding houses has increased significantly (Chen, 2019). In addition, the demographic changes such as elder care issues and declining birth rates have also had significant impact on interior design, market behavior and the overall social development of the domestic economy (Xiao, 2004).

The B2C platform has developed maturely for interior design companies and consumers. Consumers with maintain houses or rebuilt needs can easily find designers or renovation worker through the platform, but in the management of B2B projects between interior design companies and outsourced workers are still in manual and paper operation mode currently. Although there have been attempts by information service providers to develop the interior design project management system in the past, but most of the construction workers were older and weak in information application capabilities, and were repulsive or fearful of technology products, which led to their low willingness to use, so it was not easy to implement, and promotion are not effective. To this end, this research aims at the project management requirements of the interior design outsourcing work category, including project schedule planning, outsourcing inquiries and quotations, cost summary, project progress management and project acceptance, administrative closing and other functions to carry out digital designer's discussion on service solutions and value creation models of empowerment platform.

LITERATURE REVIEW

Digitalization Brings Disruptive Innovation to Various Industries

Technology always renews itself and adapts to the needs of each generation. How an enterprise invests in innovation and strategic application and choice has a key impact on whether the enterprise can operate in a sustainable manner, and there is a high risk. Many unpredictable competitors based on technological innovation have disrupted the original rules of the game for prices, services and the industry, making the original traditional industry operators unexpected. Therefore, modern enterprises are experiencing the transformative effects of digitalization on technologies in the external environment, such as competitive dynamics or customer expectations, as well as their internal environment expectations—from related business models and services provided to the organization and product structure (Downes & Nunes, 2013; Lucas & Goh, 2009; Porter & Heppelmann, 2014). Terms such as "digitalization", "digitalization" and "digital transformation" describe the impact of how technology and processes are used that

affect our daily work and the way we conduct business (Zigurat, 2019). Digitization is about converting analog information and converting it into zeros and ones so that computers can process and transmit it (Bloomberg, 2018). From the perspective of digital transformation, the business perspective is about how to use digital technology and data to generate more revenue, improve the business and create a digital culture in the company (Hapon, 2018). Routine tasks can be automated, and if used properly, it can provide employees with a better working environment. Through digitization, other tasks (such as restoring and retrieving data) will become easier (Parviainen *et al.*, 2017).

Definition of Digital Transformation

The definition of digital transformation is as follows: "Using new digital technologies (social media, mobile, analytics or embedded devices) to achieve major business improvements" (Fitzgerald *et al.*, 2013, p. 4). In other words, digitization and digitalization are part of digital transformation. Digital transformation covers all aspects of the business, such as customer understanding and touch points, growth strategies, enterprise mobile applications, process digitization, employee capabilities, performance, new business models, etc. It brings a whole new market, as well as new customers and business realities.

COVID-19 Has Accelerated the Change of Industry Development and Consumer Behavior Patterns

There is a high degree of trust between interior design companies and decoration workers. For designers, the use of materials, construction quality, personnel management, and schedule coordination for the construction workers, they are the key to the success of the interior design. For the interior design industry, whether it is easy for the designer to communicate and coordinate, the execution of construction drawing revision, and the collaboration of multiple construction teams on the site will affect whether the interior design team can complete the work smoothly as scheduled. Designers generally have a certain degree of digitization. Usually, they only need a pen, a drawing board and a computer to go to the field to receive cases, and the mobility is high. But for workers, it is relatively difficult to move the tools required for construction. Especially for those who want to go to other counties and cities to accept cases or carry out construction, they must consider whether to accept increased travel and accommodation costs.

On the other hand, it is normal for a team of construction workers to conduct multiple designer cases in the same area at the same time. Unless it is a particularly high-budget interior design case or a designer's fixed contractor, frequent travel between multiple counties and cities will cause many questions. Affected by the Covid-19 epidemic, even if the designer can accept the case, the shortage of construction manpower and imported materials is still very serious (Chen & Huang, 2020). It is foreseeable that there will be delays in construction progress, shortage of materials, and even work difficulties in the future. This situation is likely to continue to intensify.

The Digital Transformation of the Interior Design Is a Top Priority

"My country's residential interior design industry will become one of the important construction industry categories, and it should be emphasized and in-depth research field" (Zeng & Jiang, 1985). Generally, interior design companies will propose complete life solutions and planning suggestions based on customer needs and side observations. The construction period may be 3 to 4 months, or even more than a year. Whether it is the communication of owner/customer needs, construction site measurement and evaluation, design drawings and construction drawings, outsourcer coordination, furniture configuration and purchase, kitchen and bathroom equipment installation, and even installation of IoT smart home appliances, all items and processes are equivalent complicated.

Although there are already many information service companies in the market that provide ERP systems for business operation management, the current project management in the interior design industry still relies on a large amount of manpower and paper operations. In addition, during the construction period, different outsourcers often need to enter the owner/client's home to work at the same time. How to properly dispatch manpower to control costs, and effectively connect the project and management progress, resulting in budget cost control and project connection, etc., for most the interior design companies have a heavy burden. In summary, the purpose of this research is to provide a better understanding of the phenomenon of digital transformation by providing basic insights into the interior design industry, assist the company in establishing business collaboration relationships with other companies, and focus on its core business to complete the mid- to long-term Project development strategy.

RESEARCH METHOD

A research question is a question that a researcher is set out to answer. It is the driving force for most empirical studies (Yin, 2014). For the phenomenon that occurs in real life background, case study is a more commonly adopted strategy (Yin, 2002). Case study is to clarify the problem, determine the proposition and design to be analyzed, and through collection, Analyze and interpret data to establish a rich theory (Benbasat, Goldstein & Mead, 1987). Therefore, the literature review of this study first, then uses the "systematic interview" in the case study of Yin (1984) as the main research method, and finally uses the analyst triangulation

method of Patton (1980) to conduct a holistic analysis of the interviews and collected data, and re-examine the research findings to obtain research results.

Interview and System Analysis

Firstly, we conducted individual interviews with 6 interior design companies and their construction workers, and summarized their common operating procedures, including: business opportunities, project opening, design content proposal, project planning, outsourcing inquiry and customer quotation, and the other detailed tasks such as cost summary, project start-up, project execution management, acceptance check, and administrative closing, see Figure 1.

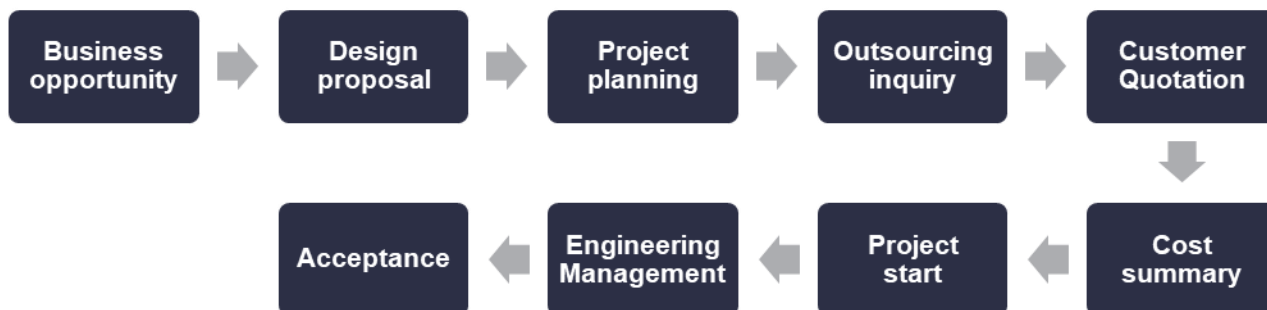

Source: This study.

Figure 1: The interior design operation process

Then discuss and determine several important nodes in the whole process with the system integrator (namely the case company), including: project schedule management, project cost management, subcontractor management, labor dispatch and scheduling, etc., and merge them into the collaborative project in the management model to simplify management operations, and digital services to improve operational management efficiency, see Table 1.

Table 1: Interior design camp work inventory

Management Item	The operation status
Project progress	<ul style="list-style-type: none"> Supervisors or designers need to ask the person in charge of each project to understand the progress of the project. The on-site construction supervisor arranges the paper records of the relevant project by manual work and reports orally by telephone.
Project cost	<ul style="list-style-type: none"> Collecting and issuing operation manually summarizes various outsourcing quotation data of the project, and summarizes it into an outsourcing cost table.
Outsourcer Information	<ul style="list-style-type: none"> Collected by the procurement personnel from the manufacturer from time to time, and the latest product and technical data are collected manually.
Vendor scheduling	<ul style="list-style-type: none"> When inquiring about the individual renovation projects, the designer’s purchaser/project management staff verbally asked the outsourcer about the available construction time. After all the outsourcers have confirmed their time, they will be manually compiled into a form.

Source: This study.

System Design and Platform Optimization

According to the above operating conditions, including system analysis, system architecture establishment, system function design, information flow design, collaborative management operations, etc. This research first compares the functions and execution systems of the existing project management platform of the case company. After upgrading and redesigning the platform interface, expand the inclusion of all stakeholders in the interior design industry, such as designers, construction workers, furniture dealers, kitchen and bathroom equipment manufacturers, air conditioners, lighting and electromechanical, smart home appliances, etc. To

improve the cross-domain integration of different industry processes, and by repositioning the service entry point of each industry in the interior design process, we have developed a cross-domain cooperation mechanism and platform viscosity, and developed a platform system solution that meets the characteristics of the interior design industry platform.

LINE Service Integration Applications

The interview results show that LINE has almost become the only communication channel in Taiwan's interior design industry. Designers and construction workers use LINE to communicate and transfer pictures so that they can interact and report the progress of the project at any time. Considering that construction workers are less likely or inconvenient to use technology products, traditional computer operations are difficult for interior design teams to adapt and operate, and to prevent preconceptions and resist the use of innovative platform service systems. This research also develops the LINE interface, which provides interaction between designers and construction workers and owners/customers as a gateway to information exchange and to the Web platform.

RESULTS AND DISCUSSION

This research sets designers as early users and provides their digital authorization platform service solutions for their project management, including project schedule, budget and outsourcer management, delivery project submission and communication channels for owners/customers. All records will be saved in the cloud database. On the other hand, for construction workers and other users with weak digital capabilities, it is planning to build the LINE@Designer authorized platform APP, and then import it back to the Web platform for use. Through the LINE @Richmenu service, we hope to use different digital levels, it is easy to collaborate and invite its customers to join and link to become an exclusive channel.

Up to now, the designer empowerment platform has completed the first phase of system testing, and its functional modules include:

- (1) Client login page: This is an entrance for designers to establish communication with owners/clients and reveal progress. After clicking, Client can directly log in to the account password set, browse project information and contact their designers. If the visitor is not a member yet, he can register directly here to obtain information about designers and the interior design industry.

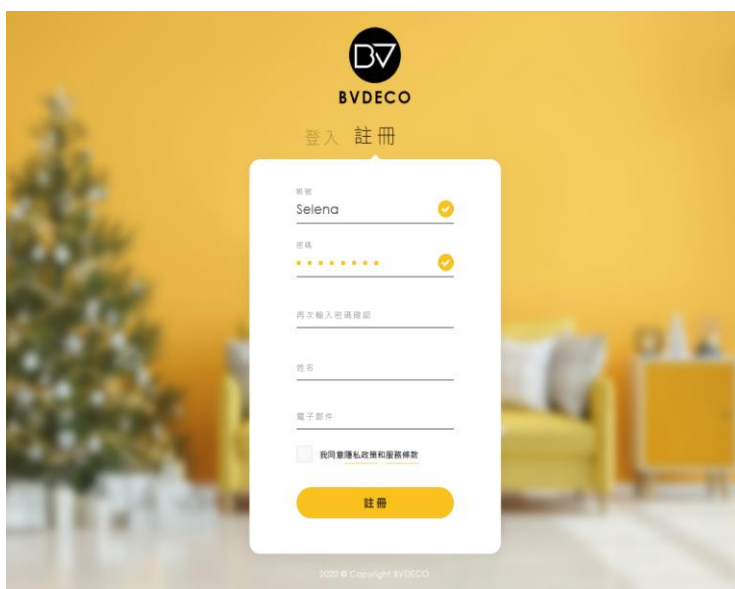

Source: This study.

Figure 2: Platform login page

- (2) Project schedule management module: This is a module that provides designers with internal project progress management. After clicking and logging in the account password, the designer or assistant can quickly enter the project status table (Dashboard), clearly sort the necessary project tasks, friendly interface reminders and when to-do items arrive, and intelligently track timetables and cost calculations. In addition, the designer can view all the work in progress at the same time, and can perform work shift manpower scheduling and schedule deployment at any time.



Source: This study.

Figure 3: Project progress page

- (3) Supplier material/construction worker shift list query and customer quotation module: This is a special module for commercial catalogs for designers and construction workers, as well as material suppliers. After the member clicks and logs in the account password, the material supplier can freely update the product and the latest quotation, and the designer can check the price according to the demand item at any time, browse the product catalog and inventory database. After the designer selects the item, the system will create an inquiry form to make an inquiry to the supplier/construction worker. After replying, the system will generate an email or line to automatically complete the process mechanism of the customer's quotation.

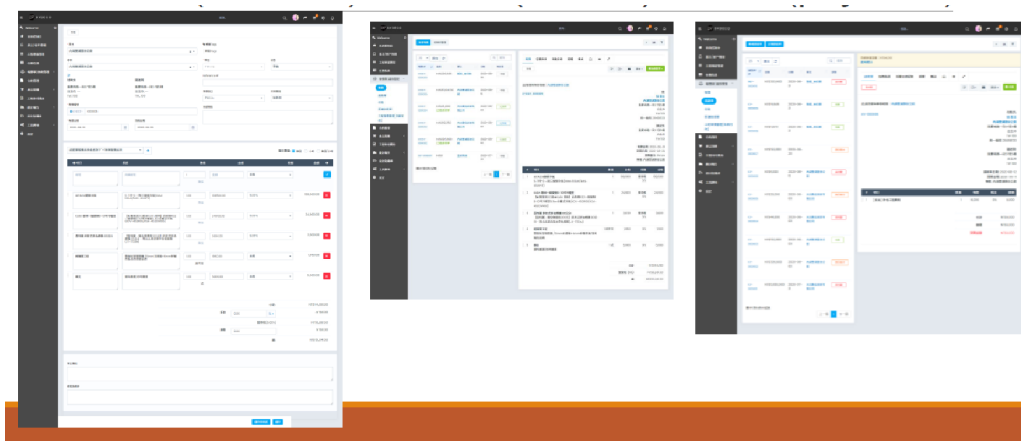

Source: This study.

Figure 4: Quotation/Request/Receipt page

- (4) Invoice issuance/receivable and payable management module: This is a module that provides designers with internal financial management. After clicking and logging in the account password, the designer or assistant can select the project progress item as completed status, submit the accountant to issue an invoice online, and record the content of the outsourcer's work and the delivery time of the product or construction. The system can also receive project revenue time comparison to ensure the balance of cash flow and revenue and expenditure, accurately grasp the financial status.

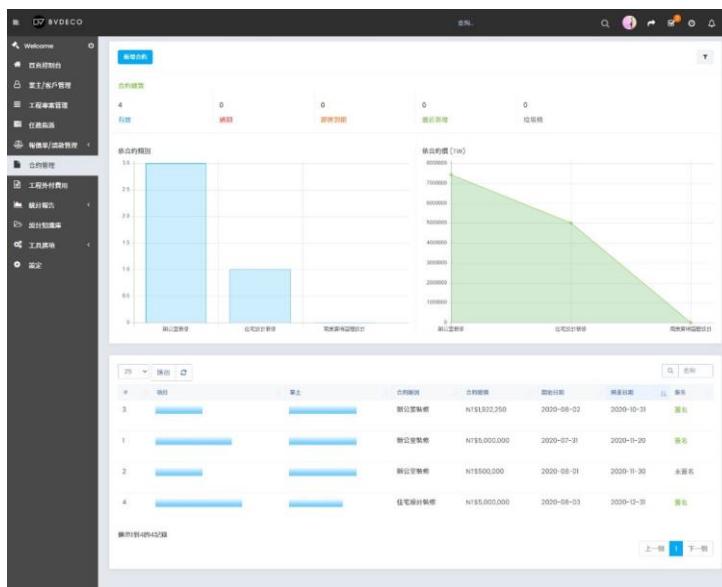

Source: This study.

Figure 5: Financial management page

- (5) Customized exclusive management platform: This is a mode that provides designers with self-configuring interfaces and functions. After the member clicks and logs in the account password, they can enter their exclusive account management platform to establish an interface style, and use his own logic to manage suppliers, customer information, project information, financial information, itinary management, product catalog management and other functions.

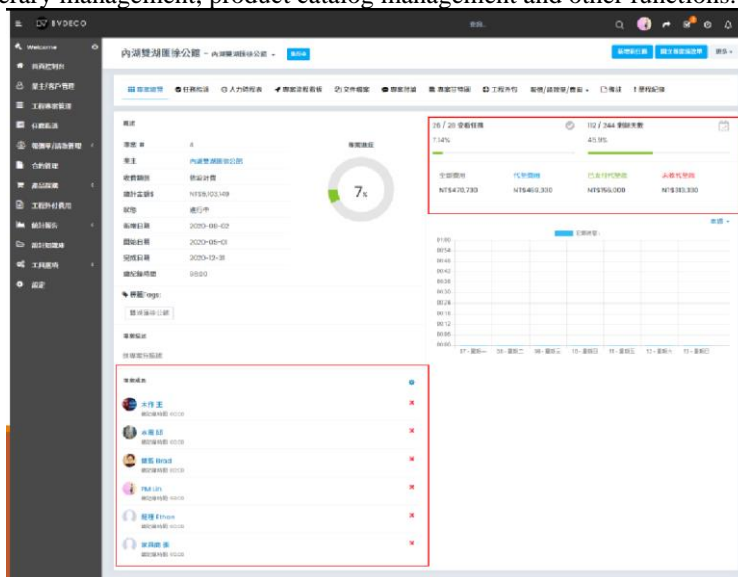

Source: This study.

Figure 6: Customized exclusive page

- (6) Smart Customer Service Assistant: This is a Line@ interface specifically for designers/construction workers/owners or customers. Members click to activate the LINE Bot robot AI to answer questions and guide each user to find the answer step by step. If each answer does not satisfy the question asked, you can send a message to the system personnel through LINE for manual customer service. Or, anyone can leave a comment or provide feedback to the system administrator through form data. This feature can make subsequent system iterations and services better.

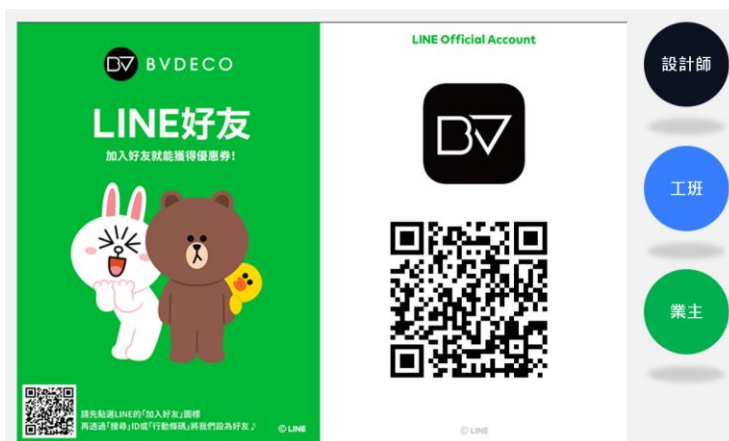

Source: This study.

Figure 7: Service entrance screen of the LINE Mini platform

In addition to the functional modules mentioned above, for the entire interior design industry, high mobility, simple operation and foolproof mechanisms are also necessary factors to increase the utilization rate of all practitioners. Therefore, the platform design must use RWD technology to upgrade the traditional operating mode of existing computer desktops or laptops to multiple carriers, such as smart phones and tablet computers, all of which have easy-to-use and easy-to-read operation interfaces.

CONCLUSION AND RECOMMENDATIONS

This research found that empirical results such as cross-industry design process integration research, system interface redesign, and end-user research that promote the interior design industry have all received positive responses from participants, indeed meeting the needs of designers. It also meets the expectations of the digital transformation of the interior design industry. For users with weak digital capabilities in the interior design industry, such as construction workers, they can connect to the system platform through an easy-to-learn interface to quickly manage various tasks, quotations and send messages, without having to search for information or products every time, and can quickly create themselves product database and catalog of LINE are very convenient. And the use channel of LINE built by the platform system allows users who do not use the system platform but can use LINE to use the menu guidance and smart customer service of LINE@. Learn new digital tools incrementally. For users with mature digital information technology, they can directly use the platform module to carry out project management, process management, drawing management, inquiry and quotation management, staff class management and other business management tools, and can further obtain many brand products Catalog information and dealer information, easy to manage quotations and costs.

In other word, the case study also confirmed that material suppliers and construction workers can actively create their own product lines and catalogs, which is very convenient for cross-industry business integration with interior designers. Anyone can easily connect to the system platform and quickly manage and execute various assigned tasks without changing habits and tool interfaces. It also proves that cross-industry platform collaboration has high business opportunities and important management implications.

Research restrictions include:

- (1) This research is a specific target (i.e., the designer has a certain reputation, the average private house receives a case amount of more than NT\$ 4 million, will use at least one design software such as AutoCAD, etc.), so the research results are divided by the number of samples Too little, further research is needed on the effectiveness of the research.
- (2) The platform system does not charge any fees during the demonstration process. Will the user feedback results be the same if the fees start in the future?

Future research directions:

- (1) It is recommended that the research objects in the future can be expanded. In addition to the designers, the construction workers and the owners/end-users can be added to further discuss the problems and needs of collaboration and use to increase the incentives for the use of digital tools.
- (2) The proposition of this research can be revised, and the research results can be confirmed by platform data or quantitative analysis.
- (3) Assist the case company to observe the use of the digital empowerment platform for a long time, and propose the use context and business model of the designer's digital empowerment platform. Through the interior design industry information platform and interface, construct an open and transparent online matching mechanism and profit-sharing model.

REFERENCES

- [1] Andrade, A. D., & Doolin, B. (2016). Information and communication technology and the social inclusion of refugees. *MIS Quarterly*, 40(2), 405–416. Doi: 10.25300/MISQ/2016/40.2.06
- [2] Benbasat, I., Goldstein, D.K., & Mead, M. (1987). The case research strategy in studies of information systems. *MIS Quarterly*, 11(3), 369-389.
- [3] Bloomberg, J., (2018). Digitization, digitalization, and digital transformation: confuse them at your peril. Retrieved from <https://www.forbes.com/sites/jasonbloomberg/2018/04/29/digitization-digitalization-and-digital-transformation-confuse-them-at-your-peril/?sh=7fd6c3fa2f2c> (accessed 1 October 2020).
- [4] Bockschecker, Alina, Hackstein, Sarah & Baumöl, Ulrike (2018). Systematization of the term digital transformation and its phenomena from a socio-technical perspective – A literature review. In *Proceedings of the 26th European Conference on Information Systems* (Research Papers. 43). ECIS, Portsmouth, UK, June 23–28. Retrieved from https://aisel.aisnet.org/ecis2018_rp/43 (accessed 1 October 2020).
- [5] Chanias, S., & Hess, T. (2016). Understanding digital transformation strategy formation: insights from Europe's automotive industry. *Proceedings of the Pacific Asia Conference on Information Systems*. College of Management, National Chung Cheng University, Chiayi, Taiwan, June27-July1. Retrieved from <https://aisel.aisnet.org/pacis2016/296> (accessed 1 October 2020).
- [6] Chen, M. L., & Huang, Q. Q. (2020). The problem of lack of labor and materials in the construction industry worsened. *Economic Daily*. Retrieved from <https://money.udn.com/money/story/5648/4487163> (accessed 4 April 2020).
- [7] Downes, L., & Nunes, P. (2013). Big bang disruption. *Harvard Business Review*, 44-56. Retrieved from <https://hbr.org/2013/03/big-bang-disruption>
- [8] Fitzgerald, M., Kruschwitz, N., Bonnet, D., & Welch, M. (2013). Embracing digital technology: A new strategic imperative. *MIT Sloan Management Review*, 55(2), 1-14.
- [9] Hapon, M., (2018). What is the difference between digitization, digitalization and digital transformation? *Netguru*. Retrieved from <https://www.netguru.com/blog/digitization-and-digitalization> (accessed 1 October 2020).
- [10] Huang, M. L., Ke, S. T., & Zheng, R. L. (2017). A Case Study of Parent-Teacher's Communication by Line APP. *Management Information Calculation*, 6(S1), 72-81. doi: 10.6285/MIC.6(S1).07
- [11] Lucas Jr, H. C., & Goh, J. M. (2009). Disruptive technology: How Kodak missed the digital photography revolution. *The Journal of Strategic Information Systems*, 18(1), 46-55. <https://doi.org/10.1016/j.jsis.2009.01.002> (accessed 1 October 2020).
- [12] Parviainen, P., Tihinen, M., Kääriäinen, J., & Teppola, S. (2017). Tackling the digitalization challenge: how to benefit from digitalization in practice. *International Journal of Information Systems and Project Management*, 5(1), 63-77. Doi: 10.12821/ijispm050104.
- [13] Porter, M. E., & Heppelmann, J. E. (2014). How smart, connected products are transforming competition. *Harvard Business Review*, 92(11), 64-88. Retrieved from <https://hbr.org/2014/11/how-smart-connected-products-are-transforming-competition>
- [14] Hung, S. C., & Tsai, B. F. (2006). Business entrepreneurship and growth: A comparative case study. *Management Review*, 14(1), 79-117. doi: 10.6160/2006.03.03 Retrieved from <https://www.airitilibrary.com/Publication/alDetailedMesh?docid=10232842-200603-14-1-79-117-a> (accessed 1 October 2020).
- [15] Xiao, J. B., Hua J. Q., Lu, B. Y., & Wang, J. R. (2004). Research on the estimation method of the residential decoration market scale (093-301070000G3-002), Institute of Architecture of the Ministry of the Interior. Retrieved from <http://www.abri.gov.tw/tw/research/show/687/p/print> (accessed 1 October 2020).
- [16] Yin, R.K. (2014). Case Study Research Design and Methods (5th edition.). *International Journal of the Canadian Journal of Program Evaluation*, 30(1), 282-287. Doi: 10.3138/CJPE.BR-240
- [17] Zeng, G. W., & Jiang, L. Q. (1985). Market-oriented value chain-residential interior decoration industry as an example, National Science Council of the Executive Yuan Special Research Project Results Report NSC 95-2221-E-224-093. Retrieved from <http://www.etop.org.tw/index.php?c=adm11252&m=getReportFile&d=adm&i=108991> (accessed 1 October 2020).
- [18] Zigurat Innovation & Technology Business School (2019). *How Digital Transformation Impacts Companies*. Retrieved from <https://www.e-zigurat.com/innovation-school/blog/how-digital-transformation-impacts-companies/> (accessed 1 October 2020).

Comparative Study of Business Models of European Micro-Mobility Online Services

(Full Paper)

Elena Vitkauskaitė*, Kaunas University of Technology, Lithuania, elena.vitkauskaite@ktu.edu

Eglė Vaičiukynaitė, Kaunas University of Technology, Lithuania, egle.vaiciukynaite@ktu.edu

ABSTRACT

The sharing economy is promoting sustainable usage of materials, equipment, and tools. Moreover, ride-sharing is a recognized means of sustainable mobility. Besides, in the wake of COVID-19 prevention measures, bicycles and e-scooters became encouraged transportation means to allow individual and non-crowded outdoor transit compared to other public transportation means. In this study, the authors aim to identify the core differentiating aspects of business models of European micro-mobility sharing online services (platforms). The Business Model Canvas framework proposed by Osterwalder and Pigneur (2010) was used as a basis to carry out the comparative analysis. The most popular European micro-mobility services were identified using the Crunchbase database, and the data on their business models was collected from secondary sources. The paper presents an analysis of four cases: Bolt (an international ride-hailing service), Nextbike (international bike-sharing service), CityBee (regional free-floating car-sharing service), and TIER Mobility (regional scooter sharing service). Future research will include a broader range of cases, interviews of the micro-mobility platform's representatives, surveys of their users, and more detailed case analysis.

Keywords: Sharing economy, Platforms, Business Models, Bike-sharing, Scooter sharing, micro-mobility, Europe.

*Corresponding author

INTRODUCTION

The sharing economy phenomenon is emerging and is driven by the rapid development and proliferation of information and communication (hereafter: ICT) enabled engagement platforms (Breidbach & Brodie, 2017). However, this phenomenon can involve different products/ services that can be accessed or delivered through collaborative practices (Netter *et al.*, 2019). As a result, the sharing economy can cover many sectors such as mobility, healthcare, hospitality, financial services, food, fashion, telecommunications, construction (Acquier *et al.*, 2019; Netter *et al.*, 2019).

The notion of sustainable mobility gained popularity recently, as well as the use of micro-mobility services. Sustainable mobility can be achieved through several key objectives: fewer trips, modal shift, distance minimization, and enhanced efficiency (Cohen & Kietzmann, 2014). Moreover, previous studies on micro-mobility services rely mainly on literature reviews rather than empirical research (Hesselgren *et al.*, 2020). Some studies have focused on a single mobility mode, such as bike-sharing (Si *et al.*, 2019; van Waes *et al.*, 2018). Meanwhile, micro-mobility might cover a more extensive list of micro-mobility services, including bike-sharing, scooter-sharing, moto-sharing and car-sharing. Hence, the single platform that integrates all diverse services has enabled the concept of Mobility as a service (MaaS) (Arias-Molinares & García-Palomares, 2020). Furthermore, all these services might have diverse business models. Indeed, as Cohen and Kietzmann (2014) have highlighted, car-sharing services can possess three unique business models such as business-to-customer (B2C), business-to-business (B2B), and peer-to-peer (P2P).

Notably, a study by Eckhardt *et al.* (2019) has highlighted that existing research studies in the sharing economy focus on business model innovations, mainly, diverse ways in which digital platforms entail value by empowering transactions between providers and users. Eckhardt *et al.* (2019) have noted that most sharing economy service providers do offer identical products or services through their digital platforms. Hence, the question remains what kind of features sharing-economy micro-mobility companies integrate into their business models? Research is needed to reveal the key attributes of their business models. The current study aims to compare European micro-mobility services' business models by applying the business model canvas framework proposed by Osterwalder and Pigneur (2010).

The paper is organized as follows. First, the literature review is presented on the research's main constructs, namely micro-mobility in the context of the sharing economy and business models. The latest research related to business models of micro-mobility platforms or services is reviewed as well. Next, the research methodology applied in this research is described. Following, the summary of the comparison of business models of selected European micro-mobility services is presented. At the end of the paper, concluding remarks are made and limitations of the research and future research directions identified.

LITERATURE REVIEW

The conceptualization of Mobility as a Service (MaaS) represents one central assumption that services are “bundled into service packages for monthly payment, as in the tele-communication or media service sector” (Pangbourne *et al.*, 2020, p. 35). Thus, MaaS is an innovative transport concept that involves a range of transport modes and services that offer a user-oriented service through a single solution (Jittrapirom *et al.*, 2018). MaaS has its centerpiece in most countries where the shared modes of public transport are provided (e.g., Uber) (Hensher, 2020). Hensher (2020) notes that micro-mobility modes include e-scooters and bicycles, car sharing, which are mainly limited to short trips. For instance, trips of e-scooters and bicycles possibly are up to 5 kilometers. Hesselgren *et al.* (2020) and Zhao *et al.* (2020) suggested the even more specific term “Corporate Mobility as a Service (CMaaS)” in a setting that uses a business-to-employee (B2E) service model instead of a general model of business-to-consumer (B2C) model.

Diverse MaaS definitions cover several key components, including several transport modes integrated with ICT solutions and a digital platform, using a user-centric approach that offers a “one-stop-shop” of mobility and requiring registration or subscription (Hesselgren *et al.*, 2020). Kamargianni & Goulding (2018) have proposed to define MaaS as “user-centric, multimodal, sustainable and intelligent mobility management and distribution system, in which a MaaS Provider brings together offerings of multiple mobility service providers (public and private) and provides end-users access to them through a digital inter-face, allowing them to seamlessly plan and pay for mobility”. Therefore, the concept of MaaS could play an essential role in the shift towards a more sustainable shared transport system (Hesselgren *et al.*, 2020).

Traditionally, the term “sharing” includes practices such as gifting, renting, swapping, or bartering and takes place at the individual or community level (Constantiou *et al.*, 2017). To indicate the entirety of actors and transactions occurring in the application of such practices, the “Sharing economy” term is often used. Sharing economy can also describe various organizations that connect users/renters and owner/providers via (digital) platforms either customer-to-customer (C2C) (e.g., Uber, Airbnb) or business-to-customer (B2C), enabling different users rentals in more flexible ways (Parente *et al.*, 2018). The notion of sharing economy can also be denoted as an umbrella term that entails various initiatives that create diverse economic, environmental, and social value (Acquier *et al.*, 2019). For example, ride-sharing platforms can promise reduced parking infrastructure in cities and create social interactions between strangers. Acquier *et al.* (2019) identified that narrow and broad approaches are used to define the sharing economy. The narrow definition states that “*tend to start from a normative characterization of sharing in order to frame the sharing economy as a more specific, restricted, and workable empirical object*” (Acquier *et al.*, 2019, p. 7). The broad definition includes both peer-to-peer (P2P) and business-to-peer (B2P) initiatives that entail market and non-market mechanisms (Acquier *et al.*, 2019).

Similarly, Netter *et al.* (2019), based on Acquier *et al.* (2017), have suggested that a definition of sharing economy should be considered as an umbrella construct that does not provide a universal definition and instead requires a detailed discourse about its different meanings and functions. According to the authors, the definition of the sharing economy needs more nuanced analysis and discussions. Therefore, Netter *et al.* (2019) have provided a new framework that emphasizes sharing models’ organizational characteristics (e.g., membership, hierarchy, rules, monitoring, sanctioning) within distinctions between user-driven/communal and platform-driven/commercial models (e.g., signing up).

According to Breidbach and Brodie (2017), the sharing economy context includes four key tenets such as access rather than ownership, the use of ICT enabled engagement platforms, financial rewards for resources’ sharing, and among numerous actors who engage in the exchange process through service ecosystems. Similarly, Parente *et al.* (2018) have proposed that there are three main characteristics of sharing economy companies: “(1) the business focuses in the unlocking the value of unused or underutilized assets; (2) consumers pay for temporary access instead of ownership using an internet-based platform and (3) it relies on network effects and social interactions between users/suppliers for growth” (p. 54). These definitions tend to follow the broad approach to the sharing economy and involve its complexity (e.g., includes both for-profit and non-profit initiatives, both B2B and B2C). In this research, we follow Netter *et al.* (2019) notion of sharing economy that is an umbrella construct for for-profit and non-profit, B2C, peer-to-peer (P2P) (also called C2C) models that allow the compartmentalization of usership and ownership of goods, services and skills.

Previous studies on micro-mobility related research focus mainly on literature reviews rather than empirical research (Hesselgren *et al.*, 2020). For instance, Mátrai and Tóth (2020) have done a scientometric analysis of 208 articles and identified four bike-sharing service clusters: purely public, purely private, mixed, and other. The public systems denote that both the operator and owner of the system are public institutions. In a similar vein, both the operator and owner of the system are private companies (Mátrai & Tóth, 2020). The mixed system represents a system when the system owner is a public entity (e.g., a city or transport operators) while the operators are private companies. The other system entails services that are not classified under the mentioned systems. For instance, Chinese companies operate differently due to their specific political structure (Mátrai & Tóth, 2020).

According to Si *et al.* (2019), the leading knowledge domains of the studies on bike-sharing published from 2010 to 2018 can be classified based on diverse generations of programs. The third and fourth generations of programs cover domains related to factors and barriers, system optimization, behavior and impact, safety and health (Si *et al.*, 2019). The fifth generation of programs covers domains classified into three types: factor and barriers, system optimization, and sharing economy (Si *et al.*, 2019). Indeed, previous studies have focused on many diverse issues related to bike-sharing, but not on bike-sharing BMs (Mátrai & Tóth, 2020). Consistent partially with (Zhao *et al.*, 2020), this research considers a business model (BM) perspective to investigate MaaS.

A growing body of literature on business models in the sharing economy emphasizes specific model attributes that companies make to run business. The business model represents “the logic and provides data and other evidence that demonstrates how a business creates and delivers value to customers. It also outlines the architecture of revenues, costs, and profits associated with the business enterprise delivering that value” (Teece, 2010, p. 173). In a business model design, diverse elements can be indicated, such as technologies selected and features that should be involved in products, benefits to customers from using these products, market segments that should be targeted, revenue streams, and mechanisms to capture value (Teece, 2010). Meanwhile, Osterwalder and Pigneur (2010) propose identifying the business model based on nine building blocks: Customer Segments, Value Propositions, Channels, Customer Relationships, Revenue Streams, Key Resources, Key Activities, Key Partnerships, and Cost Structure. This approach is further applied in this study, as it is the most used and widely cited framework for its practical relevance (Ritter & Schanz, 2019; Nußholz, 2017).

METHODOLOGY

This research aims to identify the core differentiating aspects of business models of European micro-mobility sharing platforms. The following sections provide details on selected approaches to compare the business models, selecting the cases of European micro-mobility online services and data collection.

Comparison criteria. The authors chose a comparative analysis based on the Business Model Canvas (Osterwalder & Pigneur, 2010) as the main framework. Thus, the comparison is based on these nine building blocks of Business Model Canvas as the main criteria. The selected cases were first analyzed separately to describe their business model and then developed business model canvases were compared.

Case selection. The cases were selected based on the following criteria: 1) they have to be providing micro-mobility service, 2) they have to be established in Europe; and 3) customers access the service using an internet-based platform. Crunchbase database was used to identify the cases for the analysis in this study. Crunchbase is a database of innovative start-ups and companies widely used by researchers due to the content provided on companies and linkability to other data sources (Dalle *et al.*, 2017; Ferrati & Muffatto, 2020). Query Builder of the database was used to filter the companies. First, the filter was applied to identify the companies related to micro-mobility by searching terms “Micro mobility,” “Micromobility” as well as more specific terms “Bike sharing,” “Bicycle sharing,” “Bikesharing,” and “Scooter sharing.” Next filter applied: headquarter location in Europe. Finally, expecting higher numbers of visits to platform-based service websites, a filter of monthly website visits was applied (greater or equal to 10,000). The search for the cases was carried out on 13/11/2020; search results are presented in Table 1.

Table 1: The selection of characteristics of the European micro-mobility sharing platforms using a Crunchbase database

Parameter	Rule	Restriction values	Number of results after each step	Query URL
Description	Contains any	Bike sharing; Bikesharing; Bicycle sharing; Scooter sharing; Micro mobility; Micromobility	206	https://www.crunchbase.com/search/organization.companies/96bb3b4d9b6a7bc5d728f2219ad37e29
Headquarters Location	Includes any	Europe	86	https://www.crunchbase.com/search/organization.companies/873f45c63aeb4ae0456cccd0baa8f78b
Web traffic by SEMrush: Monthly visits	Greater than or equal to	10,000	9	https://www.crunchbase.com/search/organization.companies/271f7599994962a9d0397e5666fd9b88

Source: This study.

For analysis in this paper, the top four services by monthly website traffic were selected (see Table 2): Bolt (an international ride-hailing service), Nextbike (international bike-sharing service), CityBee (regional free-floating car-sharing service), and TIER Mobility (regional scooter sharing service).

Table 2: Summary of European micro-mobility sharing companies identified on Crunchbase

Platform	Headquarters location	Monthly website visits*	Services	Geography
Bolt	Tallinn, Estonia	1,827,546	Core service: Ride-hailing. Other services: Scooter Sharing and Food Delivery	Global
Nextbike	Leipzig, Germany	158,003	Core service: Bike-sharing	Global
CityBee	Vilnius, Lithuania	51,567	Core service: Car sharing. Other services: Bike-sharing, Scooter sharing	Regional: Baltic Sea Region
TIER Mobility	Berlin, Germany	39,600	Core service: Scooter sharing	Regional: Europe
REKOLA Bikesharing	Praha, Czech Republic	13,708	Core service: Bike-sharing	Local: Czech Republic (little presence in Finland)
dott	Amsterdam, The Netherlands	13,643	Core service: Bike-sharing, Scooter sharing	Regional: Europe
Wind Mobility	Barcelona, Spain	12,014	Core service: Scooter sharing	Regional: Europe
Urent	Sovetskaya, Russian Federation	10,697	Core service: Scooter sharing	Russian Federation
Sherlock	Torino, Italy	15,192	Core service: Bike protection from theft solution.	

Source: This study. Note: *SEMrush data available on Crunchbase, as recorded on 13/11/2020.

Data collection. The qualitative research design was applied following Täuscher and Laudien (2018) to gain deep insights into business models of micro-mobility platforms. This approach ensures the collection of rich data and a more in-depth understanding of platform-based business models. Following Constantiou *et al.* (2017), the data was collected from diverse online sources.

To collect the data for the comparison of the selected cases, authors have searched titles, keywords, and abstracts for brand names of selected European micro-mobility cases (i.e., Nextbike, CityBee, “TIER Mobility”; in combination with Bolt brand name, it’s earlier brand name Taxify, and “scooter” was used in queries, as otherwise search resulted in too many sources not related to the brand, but rather to other subjects) and “business model” through Google Scholar. Researchers reviewed sources one by one and narrowed the list of references based on their availability, relevance to the study’s main focus, and ones that were more recent and up-to-date. For each case, the content of selected sources was analyzed and used until sufficient information for the description of nine building blocks of business models was reached. Additionally, the brand’s Crunchbase profile and information on their online properties (such as website, apps) were checked to ensure the resulting business model canvas is based on the business’s up-to-date state.

Table 3. An overview of secondary sources selected

Secondary sources	Bolt	Nextbike	CityBee	TIER Mobility
Research publications	Čulík <i>et al.</i> (2020); Joller (2020)	Bieliński <i>et al.</i> (2020); Petzer <i>et al.</i> (2020); Ritter & Schanz (2019)	N/A	N/A
Company’s online presence	Bolt (2020)	Nextbike (2020)	CityBee (2020); Modus Group (2019)	TIER (2020)
Crunchbase Company Profile	Crunchbase (2020a)	Crunchbase (2020b)	Crunchbase (2020c)	Crunchbase (2020d)

Source: This study. Notes: N/A – not available.

As seen from Table 3, this study uses various information sources sufficient to define business models (Hartmann *et al.*, 2016).

RESULTS SUMMARY

In this section, the authors summarize the outcomes of the analysis carried out on each case analyzed. First, we present the cases highlighting their micro-mobility services. Next, in Table 4, we summarize the key aspects of each case’s business model canvas.

Bolt (was known as Taxify until rebranding in 2019) is a global transportation platform offering ride-hailing, micro-mobility (primarily e-scooter sharing, introducing e-bike sharing as well), and food delivery from restaurants (Bolt, 2020). The company’s

legal name is Bolt Technology OÜ, established in 2013 with headquarters in Tallinn, Estonia. Currently, business counts “over 50M happy customers in 40+ countries, from Europe to Latam to Africa” (Crunchbase, 2020a). The company intends to become a micro-mobility leader in Europe by the end of 2021 by offering e-scooter sharing in over 100 cities (compared to 45 cities serviced by the end of 2019) and increasing the micro-mobility fleet to 130000 e-scooters and e-bikes (Bolt, 2020).

The primary customers of Bolt business are car-hailers on one side and car drivers to do the driving on the other side. Both are connected via the platform on an app, with trip route and price dynamically calculated in the back end (Joller, 2020). Company diversifies by providing other solutions like micro-mobility sharing (e-scooters, and since this year introducing e-bikes, serving short distance city riders) and food delivery (connecting restaurants, food orderers and couriers) to private customers, and possibilities to car or scooter fleet owners to “employ” their fleets and drivers for extra revenues, as well as franchise licenses. In car-hailing service, car maintenance costs fall under drivers responsibility, and Bolt pays the drivers only for the distance customers are driven. Čulík *et al.* (2020) research found out drivers driving for Bolt only start to pay off after more than one hundred riders per month. In micro-mobility sharing service, e-scooter and e-bike fleet development and its maintenance (distributing, charging, collecting, re-distributing, repairing, and replacing) is a significant part of costs.

Nextbike is the European market leader in bike-sharing (Nextbike, 2020). The company (legal name Nextbike GmbH) was established in 2004 with headquarters in Leipzig, Germany (Crunchbase, 2020b). Its micro-mobility systems are offered in over 300 cities worldwide. Nextbike develops and produces bicycles, rental station terminals, and related IT solutions. Nextbike (2020) claims that their business model does not rely on rental revenues of a single transaction model (as identified by Ritter & Schanz, 2019) only but is instead based on long-lasting B2B relationships with public transport operators, universities, or sustainability friendly employers. Since 2018 Nextbike added e-bikes to their bike-sharing solutions (Nextbike, 2020).

Nextbike offers a variety of tailored solutions to its B2B customers from advertising space on bicycles and mobile apps to advertisers, discounted usage fees for students of universities or employees of companies, sustainable first and last mile micro-mobility service complimenting intermodal public transportation system for public transport companies or cities and even regions (e.g., Bieliński *et al.*, 2020; Petzer *et al.*, 2020). Nextbike (2020) states that 90% of bike riders rent the bike using their app and have high satisfaction with the service, which is indicated with a 4.4 average App Store rating. The value creation side of the Nextbike business model is building on in-house development and production of high quality bikes and bike-sharing systems and maintaining the fleet throughout docked, dock-less, and virtual (free-floating) stations. The use of high-quality components (e.g., Shimano gear boxes, e-bikes engines produced by automotive supplier Brose) for bicycle production ensures the durability of bicycles, thus reducing fleet maintenance costs long term (Nextbike, 2020). Meanwhile, own production facilities allow fast and flexible production of customized designing of sponsored bike-sharing systems and placing advertising on bicycles.

CityBee (legal name Prime Leasing, Ltd) is primarily a car-sharing service provider, established in 2010 in Vilnius, Lithuania (Crunchbase, 2020c). It operates in Lithuania, Latvia, Estonia, and Poland by offering various free-floating cars (1300 cars, 150 vans) for short to long term rent. In 2019 CityBee had launched an electric scooter sharing service and became the leading micro-mobility service provider in the three Baltics countries: Lithuania, Latvia, and Estonia (Modus.group, 2019). Throughout the 2019 season, 156 thousand of CityBee’s scooter users made 468 700 trips. Bike-sharing was introduced in 2016 and originally initiated on a condition by Kaunas city municipality, who in return allowed free parking to the CityBee cars within the city. Currently, bike-sharing service is served by a fleet of 200 bicycles in some Lithuanian cities (CityBee, 2020).

CityBee (2020) app allows its users to locate and unlock the nearest available vehicle and pay for it. As users of the service are driving cars, registration requires a valid driving license. Use is charged in combining the subscription fee and usage fees (based on mileage for car renting and based on time for bike and e-scooter renting). Special prices and discounts are offered to users of business customers and in partnerships with various organizations. Vehicle maintenance, insurance, and fueling are taken care of by the company (CityBee, 2020). Meanwhile, the car fleet is sourced via dealers, while branded micro-mobility vehicles are sourced directly from producers.

TIER Mobility (also known as TIER or TIER Scooters) is a Berlin (Germany) based provider of micro-mobility sharing solutions established in 2018 (Crunchbase, 2020d). Since its establishment, it has deployed 60 000 e-scooter in 80 cities in ten countries (Ben-Hutta, 2020). In 2020 company launched an innovation – swappable batter on their micro-mobility vehicles, which can be swapped by a user at the nearest retailer shop on the Charging Network (TIER, 2020).

Business users can view and manage their employees’ usage of e-scooter renting via dedicated dashboards on the platform (TIER, 2020). Private and business users can locate, unlock, and pay for use via apps. Like Nextbike, the company cooperates with public transport companies or cities offering micro-mobility services to complement intermodal public transportation systems (Crunchbase, 2020d). The charging network offers retailers to install Charging boxes for swappable batteries. Installation and maintenance of the box are cost-free to the retailer (TIER Mobility even pays for electricity used to charge batteries). In return, it brings customers (the TIER (2020) estimates that installing the box brings on average 1,500 EUR more in revenues to the retail

location). Meanwhile, users get a discount in bonus ride time for changing the empty battery to a charged one. The solution helps the company reduce costs on maintaining their e-scooter fleet (TIER, 2020).

Table 4. Summary of European micro-mobility online services business model comparison

Business model building blocks	Bolt	Nextbike	CityBee	TIER Mobility
Customer Segments	Car drivers Private and business car-hailers Individual scooter riders Food orderers Couriers Restaurants Franchise/fleet owners	Universities Companies Municipalities Individual bike riders	Private and business car-renters Bike and scooter riders	Private and business scooter riders Companies
Value Propositions	Ride-hailing Extra income by driving/delivering Short distance mobility Food delivery service Extra revenues for employing own fleet of cars/drivers/scooters	(e-)Bike-sharing service Bike-sharing solution Advertising space (on bicycles and mobile apps)	Short to long term on-demand mobility with diverse vehicles (e.g., electric cars, cargo vans besides regular cars) Short distance mobility on scooters	Short distance mobility Customer traffic MyTIER Go e-scooters
Channels	Website/platform Apps (iOS, Android) for ride-hailing, scooters, and food Social media profiles	Website/platform Apps (iOS, Android, Microsoft) Terminals Bicycles Social media profiles	Website/platform Apps (iOS, Android) Social media profiles	Website/platform Apps (iOS, Android) Battery charging network Social media profiles
Customer Relationships	Automated & self-service Active social media communities	Automated & self-service Tailored business customer service Active social media communities	Automated & self-service B2B customer service Active and loyal social media community	Automated & self-service B2B customer service Active social media communities
Revenue Streams	Usage fee (dynamic car-hailing fee, scooter share charge time based) Franchise license fee	Subscription fees Usage fee (time-based) Sponsorship Advertising	Subscription fees in combination with usage fees (time/distance based)	Fixed unlock fee in combination with usage fees (time-based) E-scooter sales
Key Resources	Platform E-scooter/e-bike fleet Platform maintenance and customer relations staff	Production facilities and materials Platform Terminals (e-)Bicycle fleet IT and customer support staff	Platform Car/bike/e-scooter fleet Bike stations	Platform E-scooter (now e-moped also) fleet (with swappable batteries) Charging network (for swappable batteries)
Key Activities	Platform maintenance Marketing Scooter fleet maintenance	Development and production Platform maintenance Fleet maintenance and customization Rental terminal maintenance Marketing	Platform maintenance Fleet maintenance Customer relationships management/service Marketing	Platform maintenance Fleet maintenance Marketing Charging network maintenance
Key Partnerships	Municipalities Technology providers (51 diverse e-platforms/apps) Branded equipment producers (scooters, courier equipment)	Municipalities Public transport IT technology providers (29 diverse e-platforms/apps) Component/material providers (e.g., Shimano,	Municipalities Technology providers (41 diverse e-platforms/apps) Vehicle suppliers Car cleaning and repair service providers	Municipalities Technology providers (50 diverse e-platforms/apps) Producers of TIER equipment or components (batteries,

Business model building blocks	Bolt	Nextbike	CityBee	TIER Mobility
	Insurance providers	Brose)	Insurance providers Petrol station chain	scooters, charging boxes, helmets, etc.)
Cost Structure	Marketing Platform maintenance and customer relations Fleet maintenance	Marketing Platform maintenance and customer relations Bike fleet and terminal maintenance	Platform maintenance and customer relations Fleet maintenance Marketing	Platform maintenance and customer relations Fleet maintenance Marketing

Source: This study.

All four analyzed cases emphasize their contributions to sustainability goals by describing their ways and initiatives of staying carbon neutral (Bolt, 2020; Nextbike, 2020; CityBee, 2020; TIER, 2020). All four businesses also emphasize that as one of the core benefits for business customers, they use their services to show their customers and employees that they are responsible and aim to contribute to sustainability. As that is not unique to any of the cases, sustainability was not discussed separately.

CONCLUDING REMARKS

The findings reveal that European micro-mobility services are offered both as stand-alone core services (Nextbike and TIER Mobility) and additional offerings to supplement other urban mobility services (Bolt and CityBee). None of the companies analyzed rely on micro-mobility vehicle rent as the primary source of revenues. Companies with micro-mobility as a core service seem to rely stronger on business customers and partnerships with public transport companies. Naturally, the companies with micro-mobility as additional service balance out the bike and scooter usage off-season with revenues from their core activity. Micro-mobility equipment maintenance builds costs in case of all cases analyzed. However, TIER Mobility distinguishes itself with an innovative solution to reduce maintenance costs by installing swappable batteries on e-scooters, developing a charging network with local businesses, and transferring some of the efforts to charge e-scooters on users. The analysis also revealed that it is not an option in the European micro-mobility service landscape not to be sustainability conscious.

Limitations of this research are related to the scope and depth of the analysis. Business models of only four micro-mobility online services were compared: a comprehensive study of a larger sample of such platforms would lead to more conclusive findings of which aspects are most differentiating. The analysis relied on secondary sources only, and mostly only sources in English were accessed. Analysis of primary data and information available in local languages where companies operate would increase detail, especially revealing possible differences of service throughout the markets served. The study's authors intend to cover a broader range of cases, interviews of the micro-mobility platform's representatives, surveys of their users, and more detailed case analysis in future research.

REFERENCES

- [1] Acquier, A., Carbone, V., & Massé, D. (2019). How to create value (s) in the sharing economy: Business models, scalability, and sustainability. *Technology Innovation Management Review*, 9(2), 5-24.
- [2] Acquier, A., Daudigeos, T., & Pinkse, J. (2017). Promises and paradoxes of the sharing economy: An organizing framework. *Technological Forecasting and Social Change*, 125, 1-10.
- [3] Arias-Molinares, D., & García-Palomares, J. C. (2020). The Ws of MaaS: Understanding mobility as a service from a literature review. *IATSS Research*, 44, 253-263.
- [4] Ben-Hutta, A. (2020). Micro-mobility company TIER raises \$250 million series C. From *Coverager.com*. Retrieved from <https://coverager.com/micro-mobility-company-tier-raises-250-million-series-c/> (15 December 2020).
- [5] Bieliński, T., Dopierała, Ł., Tarkowski, M., & Ważna, A. (2020). Lessons from Implementing a Metropolitan Electric Bike Sharing System. *Energies*, 13(23), 6240.
- [6] Bolt (2020). Retrieved from <https://bolt.eu/en/> (15 December 2020)
- [7] Breidbach, C. F., & Brodie, R. J. (2017). Engagement platforms in the sharing economy: conceptual foundations and research directions. *Journal of Service Theory and Practice*, 27(4), 761-777.
- [8] CityBee (2020). Retrieved from <https://www.citybee.lt/en> (15 December 2020)
- [9] Cohen, B., & Kietzmann, J. (2014). Ride on! Mobility business models for the sharing economy. *Organization & Environment*, 27(3), 279-296.
- [10] Constantiou, I., Marton, A., & Tuunainen, V. K. (2017). Four models of sharing economy platforms. *MIS Quarterly Executive*, 16(4), 231-25.
- [11] Crunchbase (2020a). Bolt. Retrieved from <https://www.crunchbase.com/organization/mtakso> (15 December 2020)
- [12] Crunchbase (2020b). Nextbike. Retrieved from <https://www.crunchbase.com/organization/nextbike> (15 December 2020)
- [13] Crunchbase (2020c). CityBee. Retrieved from <https://www.crunchbase.com/organization/citybee-719c> (15 December 2020)

- [14] Crunchbase (2020d). TIER Mobility. Retrieved from <https://www.crunchbase.com/organization/tier-mobility> (15 December 2020)
- [15] Čulík, K., Kalašová, A., & Otahálová, Z. (2020). Alternative taxi services and their cost analysis. *Transportation Research Procedia*, 44, 240–247.
- [16] Dalle, J., M. den Besten and C. Menon (2017). Using crunchbase for economic and managerial research. *OECD Science, Technology and Industry Working Papers*, No. 2017/08, OECD Publishing, Paris.
- [17] Eckhardt, G. M., Houston, M. B., Jiang, B., Lamberton, C., Rindfleisch, A., & Zervas, G. (2019). Marketing in the sharing economy. *Journal of Marketing*, 83(5), 5-27.
- [18] Ferrati, F., & Muffatto, M. (2020). Using crunchbase for research in entrepreneurship: data content and structure. In *20th European Conference on Research Methodology for Business and Management Studies: ECRM 2020* (p. 342). Academic Conferences and publishing limited.
- [19] Hartmann, P. M., Zaki, M., Feldmann, N., & Neely, A. (2016). Capturing value from big data—a taxonomy of data-driven business models used by start-up firms. *International Journal of Operations & Production Management*, 36(10), 1382-1406.
- [20] Hensher, D. A. (2020). What might Covid-19 mean for mobility as a service (MaaS)? *Transport reviews* 2020, 40(5), 551-556.
- [21] Hesselgren, M., Sjöman, M., & Pernestål, A. (2020). Understanding user practices in mobility service systems: Results from studying large scale corporate MaaS in practice. *Travel Behaviour and Society*, 21, 318-327.
- [22] Jittrapirom, P., Marchau, V., van der Heijden, R., & Meurs, H. (2018). Dynamic adaptive policymaking for implementing Mobility-as-a Service (MaaS). *Research in Transportation Business & Management*, 27, 46-55.
- [23] Joller, L. (2020). Who is embracing the short-term rental of electric cars? A case study on Estonia. *Case Studies on Transport Policy*, 8(3), 796–811.
- [24] Kamargianni, M., & Goulding, R. (2018). The Mobility as a service maturity index: Preparing the cities for the mobility as a service era. *Transport Research Arena*, 7, 17-21.
- [25] Mátrai, T., & Tóth, J. (2020). Cluster analysis of public bike sharing systems for categorization. *Sustainability*, 12(14), 5501.
- [26] Modus.group (2019). CityBee completes its first electric scooter season, notes clear differences among the Baltic countries. In *modus.group*. Retrieved from <https://www.modus.group/News/CityBee-completes-its-first-electric-scooter-season%2C-notes-clear-differences-among-the-Baltic-countries> (27 December 2019)
- [27] Netter, S., Pedersen, E. R. G., & Lüdeke-Freund, F. (2019). Sharing economy revisited: Towards a new framework for understanding sharing models. *Journal of Cleaner Production*, 221, 224-233.
- [28] Nextbike (2020). Retrieved from <https://www.nextbike.de/en/> (15 December 2020)
- [29] Nußholz, J. L. (2017). Circular business models: Defining a concept and framing an emerging research field. *Sustainability*, 9(10), 1810, 1-16.
- [30] Osterwalder, A., & Pigneur, Y. (2010). *Business model generation: a handbook for visionaries, game changers, and challengers*. John Wiley & Sons.
- [31] Pangbourne, K., Mladenović, M. N., Stead, D., & Milakis, D. (2020). Questioning mobility as a service: Unanticipated implications for society and governance. *Transportation Research Part A: Policy and Practice*, 131, 35–49.
- [32] Parente, R. C., Geleilate, J. M. G., & Rong, K. (2018). The sharing economy globalization phenomenon: A research agenda. *Journal of International Management*, 24(1), 52-64.
- [33] Petzer, B. J. M., Wiczorek, A., & Verbong, G. (2020). Cycling as a service assessed from a combined business-model and transitions perspective. *Environmental Innovation and Societal Transitions*, 36, 255–269.
- [34] Ritter, M., & Schanz, H. (2019). The sharing economy: A comprehensive business model framework. *Journal of Cleaner Production*, 213, 320–331.
- [35] Si, H., Shi, J. G., Wu, G., Chen, J., & Zhao, X. (2019). Mapping the bike sharing research published from 2010 to 2018: A scientometric review. *Journal of cleaner production*, 213, 415-427.
- [36] Täuscher, K., & Laudien, S. M. (2018). Understanding platform business models: A mixed methods study of marketplaces. *European Management Journal*, 36(3), 319–329.
- [37] Teece, D. J. (2010). Business models, business strategy and innovation. *Long range planning*, 43(2-3), 172-194.
- [38] TIER (2020). Retrieved from <https://www.tier.app/> (15 December 2020)
- [39] van Waes, A., Farla, J., Frenken, K., de Jong, J. P., & Raven, R. (2018). Business model innovation and socio-technical transitions. A new prospective framework with an application to bike sharing. *Journal of Cleaner Production*, 195, 1300-1312.
- [40] Zhao, X., Vaddadi, B., Sjöman, M., Hesselgren, M., & Pernestål, A. (2020). Key barriers in MaaS development and implementation: Lessons learned from testing Corporate MaaS (CMaaS). *Transportation Research Interdisciplinary Perspectives*, 8, 100227.

Digital Transformation Research of Taiwan's Traditional Manufacturing Industry based on the Ecosystem Perspectives

(Full Paper)

Chia-Yu Jih*, National Chengchi University, Taiwan, 107356503@nccu.edu.tw

Wei-Hsi Hung, National Chengchi University, Taiwan, fhung@nccu.edu.tw

ABSTRACT

Taiwan's traditional manufacturing has great impact for the economic take-off, and is an important force for stabilizing the domestic social economy and livelihood. However, with the rapid development of liberalization and globalization, high-tech industries have emerging and replaced it. With recent domestic and international economic situations such as the US-China trade war, the low-price competition from emerging countries and the continued spread of the COVID-19 epidemic have made the traditional export-oriented manufacturing industry face more severe challenges. On the other hand, Taiwan's traditional manufacturing industry uses industrial clusters as the main operating mode, but emerging technology has brought disruptive innovations. So, many businesses look to develop new business models based on data. Due to cluster mode, this has driven many cross-industry and cross-field innovation ecosystems in Taiwan traditional manufacturing market and cascading to global industrial chains. The objective of this paper is to find out the paths for the digital transformation of Taiwan's traditional manufacturing industry. This study will use Jacobides, Cennamo, and Gawer's "Towards a theory of ecosystems" as the analysis framework to investigate the specific innovation or new value proposition of traditional manufacturers in Taiwan, as well as identify possible complementary support group relations and proposed a transition mode and from concept to enterprise management implications practice.

Keywords: Digital transformation, ecosystem, traditional manufacturing industry, strategy development

*Corresponding author

INTRODUCTION

Definition and Scope of Traditional Manufacturing Industries

There is no consistent classification definition statement for the traditional manufacturing agreed by the government and academic institutions in Taiwan. The definitions are mostly based on the purpose of data usage purpose and the difficulty of obtaining. According to the 2014 "Promotion Plan for Value-added Transformation of Traditional Industries" compiled by the Ministry of Economic Affairs, academic research advocates adopting "market-side" or "technical-side" as categories.

The basic "market-side" view is that the industry was once the economy with a contribution rate of at least 15-20% or more, but today's market position has declined to 5% or even below 1%, and should be classified as traditional industries. Therefore, traditional industries should belong to the "mature" period in the product life cycle. Those market shares will no longer increase or even have begun to decline (Cai, 2000). So, these industries are in the mature period and declining period. Scholars also have proposed that traditional industries must have two characteristics. First is the output value and profits of the industry show long-term decline; second, the cause of the decline or recession has no related to the business cycle. (Wang, 2001) There are also scholars who define any industries that are closely related to people's livelihood such as food, clothing, housing, construction, and automobiles, including upstream and downstream industries such as steel, petrochemical, mold, machinery, plastics, and building materials have categorized into traditional industry. (Xu & Liao, 2000)

The aspect of "technical side" view is to define high-tech industries first, which means to classify industries the electronics industry, finance and insurance industry, electrical machinery industry and construction industry, the rest of industries are categorized into traditional industries. The common categorization indicator is the ratio of research and development (R&D) expenses to the total sales output value, and the proportion of scientific and technical personnel in total employees. However, the government statistical department usually defines the scope of traditional industry based on the convenience of data collection and comparison. For instances, in the statistical data department of the General Accounting Office of the Executive Yuan, the following industries are mainly classified as the traditional manufacturing industry: (1). "Agriculture industry" - agriculture, forestry, fishery, animal husbandry, (2). "Manufacturing Industry" - mining, manufacturing, water, electricity and gas industry, construction industry, and (3). "Service industry". These three industries are generally known as primary, secondary and tertiary industries. In

2010, the Ministry of Economic Affairs formulated the "Plan for Improving the Competitiveness of Traditional Industries", which defined traditional industries as "industries other than strategically important emerging industries". The strategically important emerging industries which are selected and defined by the Ministry of Economic Affairs according to 2009 "Regulations on of Promoting Industrial Upgrading" as "the emerging important strategic industries that have significant benefits for economic development, high risks and urgently need to be supported". Any other not in such categories belong to traditional industries. So, accordingly, the 2012 "Research on Traditional Industry Renovation Strategies" proposed by the Economic Development Committee of the Executive Yuan has defined the traditional industries as the following table.

Table 1: Traditional industry listing in Taiwan

Categories	Classification.	Items
Manufacturing	Traditional manufacturing	Food industry, beverage industry, tobacco industry, textile industry, clothing and apparel products industry, leather, fur and its products industry, wood and bamboo products industry, pulp, paper and paper products industry, printing and data storage media reproduction industry, petroleum and media Product industry, chemical material industry, chemical product industry, pharmaceutical industry, rubber product industry, plastic product industry, non-metallic mineral product industry, basic metal industry, metal product industry, machinery and equipment industry, automobile and its parts industry, other transportation tools industry , Furniture industry, other manufacturing and industrial machinery and equipment maintenance and installation industry.
	Non-traditional manufacturing	Electronic components, computer electronic products and optical products, power equipment manufacturing
Services.	Non-knowledge-intensive services (traditional industries).	Wholesale and retail industry, transportation and storage industry, accommodation and catering industry, real estate industry, art, entertainment and leisure service industry.
	Knowledge-intensive services	Commodity brokerage, postal, telecommunications, computer system design services, portal operations, data processing, website hosting and related businesses, finance and insurance, professional scientific and technical services (excluding veterinary serv.
Agriculture	All belong to traditional industries	agriculture, forestry, fishery, animal husbandry

Source: The Council for Economic Planning and Development of the Executive Yuan, R.O.C. (Taiwan), 2012.

Due to the various definitions of traditional industries by academia and government agencies, the economic impact by industry types and company scales are also different. Therefore, the author summarizes the above-mentioned definitions to conclude the characteristics of traditional industries include: (1). the contribution of the economy to the economy has declined significantly under long-term observation, (2). the production technology has matured, and (3). R&D and equipment inputs do not account for a high proportion of output. To ensure that the research objects consistent with industry attributes, this study will use the industry categories proposed by the Economic Development Council in 2012.

The Realization of Ecosystem Innovation Viewpoints

"Ecosystem" has become an important term for industrial innovation, as well as a new way to describe the competitive environment. Despite there are different translations for "ecosystem" in Chinese, the main view of ecosystem means to break away from the traditional supply chain and value chain thinking, leading manufacturers to re-define the value proposition and pattern of corporate innovation. In the early stage of ecosystem planning, it needs to emphasize the innovative viewpoints of integrating overall service process and structure in order benefiting and connecting multiple stakeholders including customers in a high-level perspective. Effectively inlaid together to form a positive circulation and cooperation atmosphere with a suitable supply and demand (Chen & Chang, 2015). Ecosystem not only entered technology companies' mindset, but also entered mature industries such as financial services. (Deloitte, 2015)

Beside the popular business media reports, ecosystems have also been eagerly adopted by strategic areas. Teece (2014) proposed that “the concept of ecosystems can now replace industry analysis.” Although ecosystems have been considered in our research field for a while, there has been a boom in the academic research area in recent years. (Dhanaraj & Parkhe, 2006; Iansiti & Levien, 2004; Moore, 1993) Searching for the keyword ecosystem in the titles or abstracts of top strategic journals shows that its frequency has increased sevenfold in the past five years. Jacobides, Cennamo and Gawer (2018) believe that modularity of ecosystem can promote the emergence of ecosystems research which prompting the organization to coordinate newly completely planning for interdependent ordinance. In other words, the value of the ecosystem created by the leading manufacturer can coordinate its dependence on multilateralism through a series of similar roles, thereby avoiding the need to sign a customized contract agreement with each partner. Based on previous research output, this research will according to the ecosystem model proposed by Jacobides *et al.* (2018), discuss how to use the ecosystem to optimize the digital transformation of traditional manufacturing industry by rearrange or integrate the supply chain vertically, and to develop grouping relationships that may be recognized and complementary to support, to establish an ecosystem with strategic purpose.

PROBLEM STATEMENT

Despite the economic output, the number of traditional manufacturing company accounts for more than 90% of Taiwan enterprises that play an important role and position in economic and trade development which lead to an important force for stabilizing the social economy and people's livelihood. Since the 1970s, Taiwan's traditional manufacturing industries have adopted industrial clusters as the main operating mode. They exist in cities and towns geographically, but connected and allied to produce various in heterogeneous ways. The government vigorously promoted this operation mode over years. By participating in overseas exhibitions of public associations and jointly seeking OEM orders jointly shipped through capacity sharing, forming a unique development model for Taiwan's industrial exports, creating a world-famous economic miracle, and letting Taiwan Become a veritable manufacturing kingdom. According to the Swiss World Economic Forum (WEF) 2019's “The Global Competitiveness Report”, Taiwan ranked 4th position and continues to rank among the top four innovative countries, Taiwan also ranked 3rd position in “the degree of universality of development”. This ranking is mainly due to the “complete industrial clusters operation mode to create an innovation ecosystem for leading advantage”. Taiwan's traditional industry that is urban innovation ecosystem foundation affects the overall Taiwan economic innovation momentum. However, according to the Taiwan Economic Research Institute in November 2019, and observed that the last five-year export growth has stagnated for some traditional manufacturing industries, while China's export value has grown from 13.27 billion to 22.27 billion (+67.82%). It is obvious that Taiwan has the hidden concern of insufficient export momentum, possibly due to the degree of this innovation ecosystem.

The diversified and low-cost competition and rise of emerging countries were the challenges both in domestic and foreign economic conditions. Due to the production lines of some traditional industries were mostly moved to China or other Southeast Asian countries. The demographic advantage is gradually reduced, the human location no longer has advantages, and the Internet The rise and increase of owners are more likely to find competitors or alternatives in the same industry, causing companies to start cutting prices and competing for orders and are forced to sacrifice profits. Coupled with the recent continuous spread of the COVID-19 epidemic, it is not easy for outside factories to recruit (return) workers and relocate (expand) factories, raw material prices and production costs have increased significantly, and manufacturers' profitability and production efficiency are difficult to recover in the short term. The domestic environment is faced with high turnover rate, lack of professional managers, most unique knowledge is only passed on within the family, product improvement research and development momentum are limited, the industry lacks cross-field talents for cross-industry integration and design integration, and second-generation succession There are many problems to be overcome, such as innovative intentions or ideas but difficult to put into practice.

Under the influence of the global economy and the trend of digital transformation, more countries need to face the market competition, not limited to the technology, talents, and markets, but also the allocation of own resources and integration with other ecosystems need to be considered. The digital transformation process is highly risky, challenging, and staged, especially in facing unknown markets, cross-industry competitors, different thinking required in cross-fields, and even difficulties in obtaining information in the evaluation process, which will cause interpretation and difficulties in decision-making. Therefore, to help break through the challenged industrial survival dilemma, this research will focus on exploring the core roles established by traditional manufacturing industry knowledge, and use the ecosystem model to integrate and collaborate across business fields, and propose innovations in multi-fields. The development strategy recommendations for product domain services are expected to serve as a reference basis for the digital transformation model of the traditional industry.

RESEARCH METHODS

Recently, in many research strategies and practices, people's interest in "ecosystems" has surged, mainly focusing on what is an ecosystem and how it operates. According to a literature review conducted by Jacobides, Cennamo & Gawer (2018), the study supplements these documents by considering when, why and why the ecosystem is different from other forms of governance, and

incorporates them into the ecosystem. It is different from other business systems, including markets, alliances or hierarchical management of supply chains.

Therefore, this study uses the above three ecosystems with different value chain structures, including: (1) Business Ecosystem, centered on the company and the surrounding environment. (2) Innovation Ecosystem, around a specific innovation or new value proposition, and a specific group that agrees with its business values. (3) Platform Ecosystem, based on how participants develop around the platform, and on this basis, this research hopes to help Taiwan’s traditional manufacturing industry to further understand the development of different ecosystem strategies.

Business Ecosystem

Business ecosystem research mainly focuses on a single company or a new enterprise, which is an economic community of mutual influence participants. This kind of ecosystem influences each other through the activities of their respective enterprises, and even affects all relevant participants outside the scope of a single industry. The business ecosystem represents the environment that enterprises must monitor and respond to, which affects the dynamic capabilities of the enterprise itself and whether it is the ability to build sustainable competitive advantage (Teece, 2007). Despite the emphasis on corporate capabilities to work together, authors such as Iansiti and Levien (2004) emphasized ecosystem-led enterprises as a functional role to providing cooperation between members, but how do leading enterprises make knowledge flow, innovation proprietary and belonging, and how members adapt to maintain the stability of the network. Overall, there is a lack of supporting evidence from scholars and market experience in related literature studies.

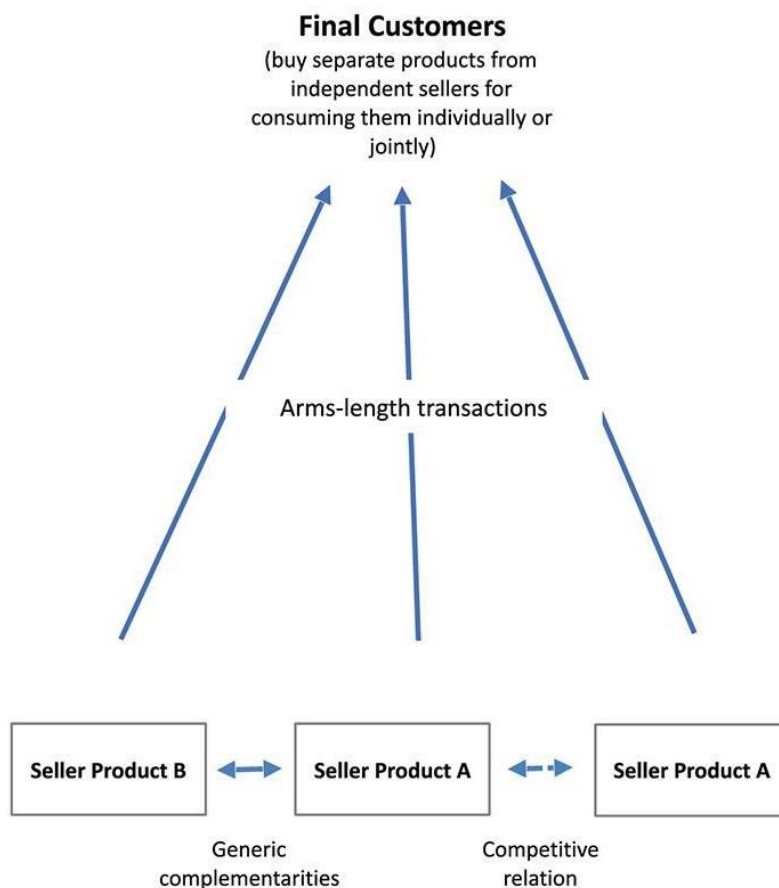
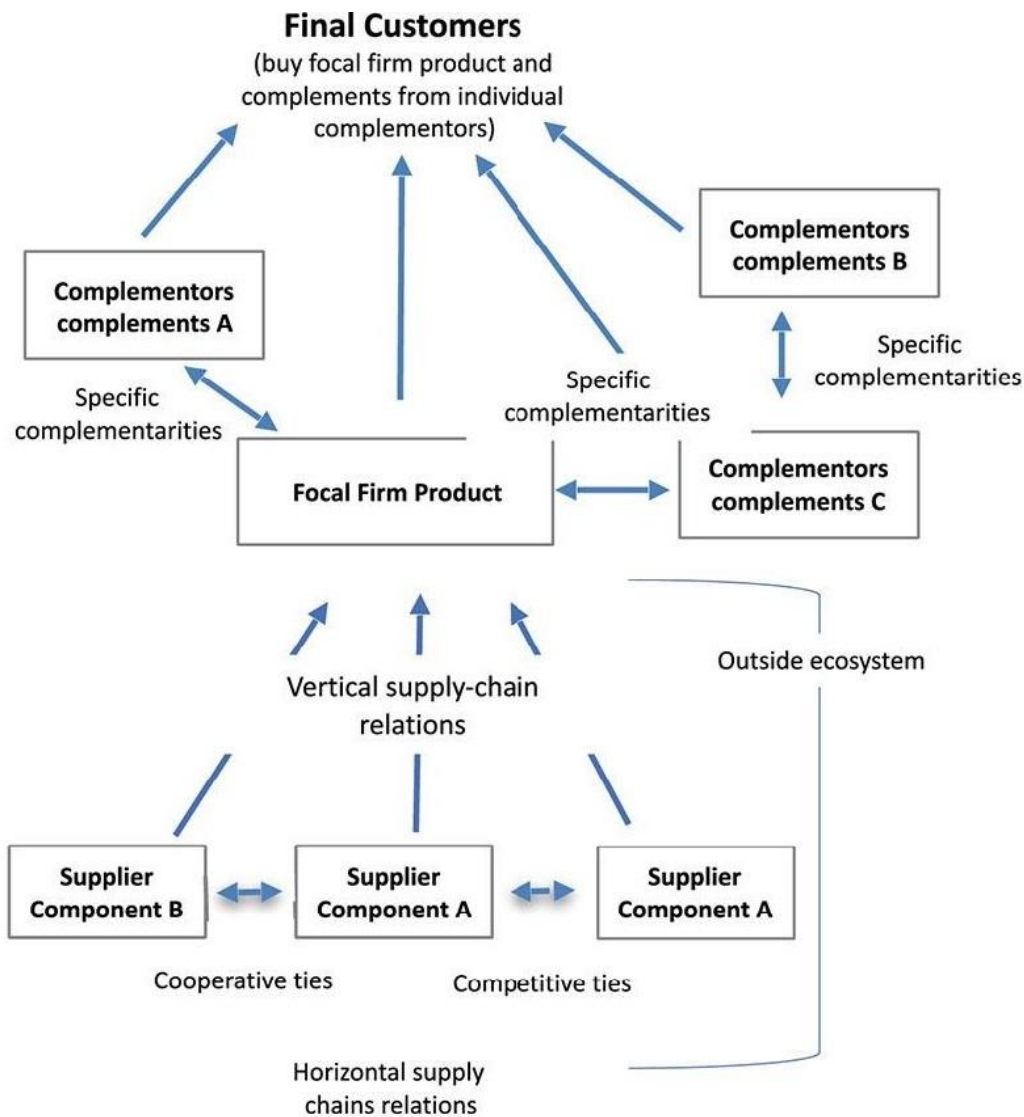

Figure from: https://www.researchgate.net/publication/323916602_Towards_a_Theory_of_Ecosystems
 Figure 1: Market-based value systems

Innovation Ecosystem

Innovation ecosystem focuses on key innovations and supports upstream entities that support innovation to supplement downstream entities. The entities, companies or government agencies, collaborate to produce value-added product and propose solutions to customers (Adner, 2006). The focus of innovation ecosystem is to understand how interdependent participants interact

with each other to create and commercialize to benefit end customers, and keep the coordination within the ecosystem for sustainability purpose. (Adner & Kapoor, 2010; Adner, 2012; Kapoor & Lee, 2013) Ecosystem development lies in establishing the relationship between co-created products and their components or complementary products or services to jointly add value to customers; the extent to which companies participating in the ecosystem adjust through different arrangements will affect their ability to ultimately create value for customers (Adner, 2017). The ecosystem can form a virtual network (Iyer *et al.*, 2006) to provide focused and complementary innovations. How to share knowledge will affect the strength of the relationship between enterprises, thereby affecting the strategy development of enterprises. (Alexy *et al.*, 2013; Brusoni & Prencipe, 2013; Frankort, 2013) How knowledge sharing within ecosystem affects the strength of the relationship between enterprises, and thus affects the development and status of ecosystem as whole. (Leten *et al.*, 2013; West & Wood, 2013).



Source: https://www.researchgate.net/publication/323916602_Towards_a_Theory_of_Ecosystems

Figure 2: Ecosystem-based value systems

Platform Ecosystem

Platform Ecosystem research focuses on specific types of platform technologies, and the interdependence between platform sponsors and their complements. Based on this point of view, the ecosystem includes platform sponsors and all supplementary suppliers who make the platform more valuable to consumers (Ceccagnoli *et al.*, 2012). In essence, the platform ecosystem tends

to be radial. In the form of development, various companies connect to the platform through shared or open source technologies and technical standards. Supplementary programs can not only generate complementary innovations, but also directly or indirectly gain access to platform customers. Therefore, the platform ecosystem is seen as a "semi-regulated market" (Wareham, Fox & Cano Giner, 2014) that promotes corporate actions under the coordination and guidance of platform sponsors, or as a realization between different user groups the "multilateral market" of transactions (Cennamo & Santaló, 2013).

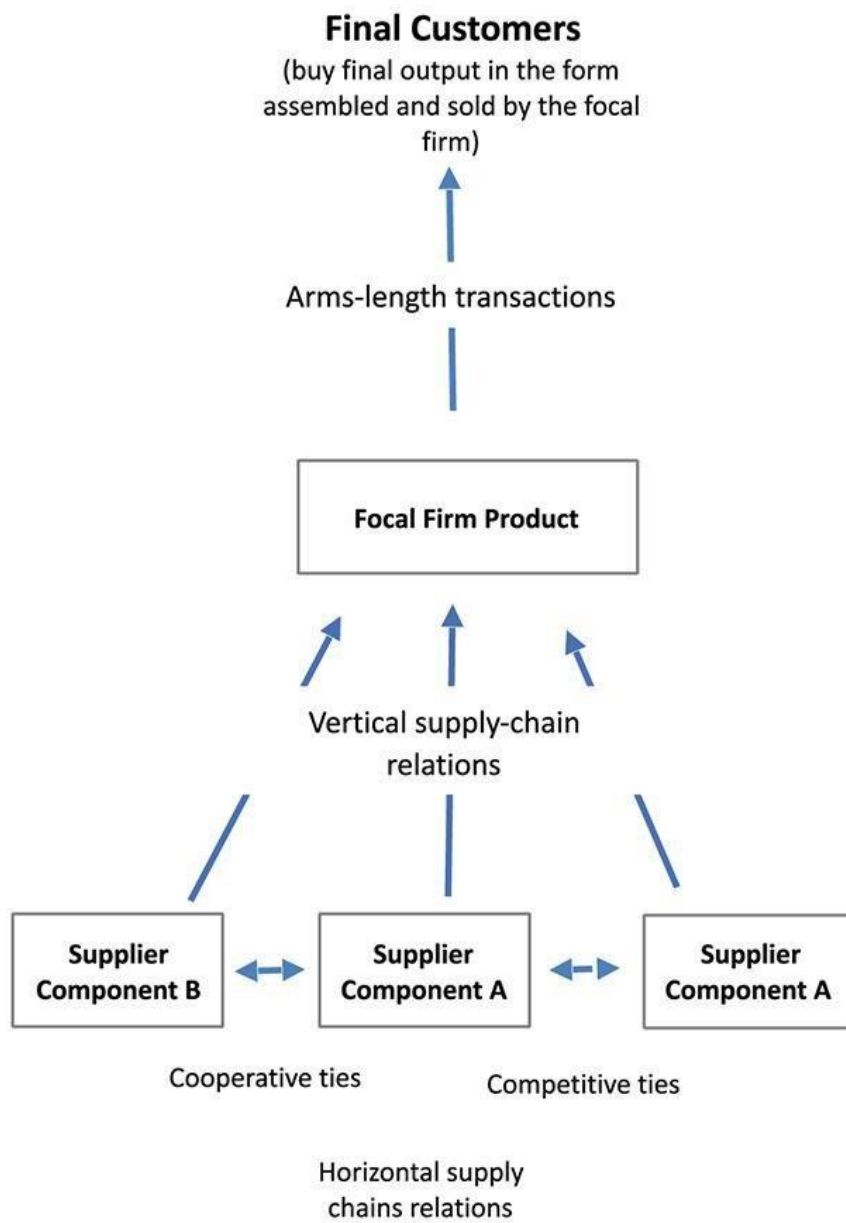

Source: https://www.researchgate.net/publication/323916602_Towards_a_Theory_of_Ecosystems

Figure 2: Hierarchy-based value systems

RESULTS AND DISCUSSION

The objective of this research is to assist Taiwan's traditional manufacturing industry in understanding the ecosystem, and to explore how to form an interdependent yet independent network by sorting out the complementarity and key issues of different types of ecosystems. In fact, the digital transformation of traditional industries or enterprises has considerable risks and challenges, especially in the face of unknown markets or cross-industry different thinking. It is difficult to obtain information in the evaluation process of digital transformation especially in ecosystem type strategy. So, it is relatively difficult to interpret and make decisions for the strategy forming. Based on the consideration of the past development and current situation of Taiwan's traditional manufacturing industry, strategic thinking should be more inclusive, rather than hope that a single element or component can be promoted. Based on this, this study suggests that Taiwan's traditional manufacturing industry at this stage should develop the "innovative ecosystem" strategic model.

According to the Brookings Institution (2017) the innovation study of North American regions pointed out that only a cluster of industries with an active innovation ecosystem can promote the sustainable development of sub regional towns. The key successful factors to the active innovation ecosystem are the three type of assets: physical assets, economic assets and network assets which interact with each other. Although this research discusses the digital transformation strategy of Taiwan's traditional manufacturing ecosystem, it is also important to point out a single company or enterprise needs to continuously invest in R&D and strengthen core capabilities to ensure irreplaceability in the ecosystem, or cross-domain to other the mobility of ecosystem cooperation.

CONCLUSION

At present, ecosystem research has not developed in the mainstream literature. No matter which type of ecosystem is, complementary innovation providers, products or services are required to emphasize that the output of the ecosystem must be unique or novel place. It is also the result based on this study show that the digital transformation for Taiwan's traditional manufacturing industry must shift from the import ecological view to ecosystem view. This strategy will lead enterprises to expand and promote the inclusion of different industries to cooperate, and not limited in traditional supply chain relationship. Moreover, important interdependence can still be established. However, due to the relatively complex sub-sectors of Taiwan's traditional manufacturing industry, issues such as core technology, digital application capabilities, leader behavior and intentions are needed to define by the coordination of a collection of multilateral partners interact to achieve the value propositions. Effectively balancing control of ecosystem governance and achieving the collective results have become key issues and challenges for follow-up research on ecosystem cooperation. Therefore, it is recommended that follow-up research can target specific companies as a hub, which can further deepen the network density and collaboration mode of the ecosystem. Discussing the companies increasingly participate in and respond to the growth of the ecosystem, the research results they provide will enrich the research on ecosystem types and enhance the value of mainstream strategy research for corporate transformation.

REFERENCES

- [1] Adner, R. (2006). Match your innovation strategy to your innovation ecosystem. *Harvard Business Review*, 84(4), 98-107.
- [2] Adner, R., & Kapoor, R. (2010). Value creation in innovation ecosystems: How the structure of technological interdependence affects firm performance in new technology generations. *Strategic Management Journal*, 31(3), 306-333.
- [3] Adner, R. (2012). *The Wide Lens: A New Strategy for Innovation*. Penguin, UK.
- [4] Adner, R. (2017). Ecosystem as structure: An actionable construct for strategy. *Journal of Management*, 43(1), 39-58.
- [5] Alexy, O., George, G., & Salter, A. J. (2013). Cui bono? The selective revealing of knowledge and its implications for innovative activity. *Academy of Management Review*, 38(2), 270-291.
- [6] Brusoni, S., & Prencipe, A. (2013). The organization of innovation in ecosystems: Problem framing, problem solving, and patterns of coupling. *Collaboration and Competition in Business Ecosystems (Advances in Strategic Management, Vol. 30)*, Emerald Group Publishing Limited, pp. 167-194.
- [7] Ceccagnoli, M., Forman, C., Huang, P., & Wu, D. J. (2012). Cocreation of value in a platform ecosystem! The case of enterprise software. *MIS Quarterly*, 36 (1), 263-290.
- [8] Cennamo, C., & Santaló, J. (2013), Platform competition: Strategic trade-offs in platform markets. *Strategic Management Journal*, 34(11), 1331– 1350.
- [9] Chen, X. H. & Chang, C.J. (2015). Further interpretation of ecosystem innovative views. *Economic Outlook*, 162, 113-116. Retrieved from <https://www.airitilibrary.com/Publication/alDetailedMesh?docid=10190376-201511-201512210014-201512210014-113-116> (accessed 1 October 2020).
- [10] Frankort, H. T. (2013). Open innovation norms and knowledge transfer in interfirm technology alliances: Evidence from information technology, 1980-1999. *Advances in Strategic Management*, 30, 239-282.
- [11] Iansiti, M., & Levien, R. (2004). *The Keystone Advantage: What the New Dynamics of Business Ecosystems Mean for Strategy, Innovation, and Sustainability*. Harvard Business Press, Boston, MA.
- [12] Iyer B, Lee CH, Venkatraman N. (2006), Managing in a small world ecosystem: some lessons from the software sector. *California Management Review*, 48 (3), 28-47.

- [13] Jacobides, M. G., Cennamo, C., & Gawer, A. (2018). Towards a theory of ecosystems. *Strategic Management Journal*, 39(8), 2255-2276.
- [14] Kapoor, R., & Lee, J. M. (2013). Coordinating and competing in ecosystems: How organizational forms shape new technology investments. *Strategic Management Journal*, 34(3), 274-296.
- [15] Leten, B., Vanhaverbeke, W., Roijackers, N., Clerix, A., & Van Helleputte, J. (2013). IP models to orchestrate innovation ecosystems: IMEC, a public research institute in nano-electronics. *California Management Review*, 55(4), 51-64.
- [16] National Development Council Department of Economic Affairs (2019), China ranks 12th in WEF's global competitiveness in 2019, continues to improve, rises one more place, and continues to rank among the top four innovators, 108-10-09, https://www.ndc.gov.tw/News_Content.aspx?n=114AAE178CD95D4C&s=E38618A0C03F7EC0
- [17] Porter ME. (1980). *Competitive Strategy: Techniques for Analyzing Industries and Competitors*. Free Press: New York.
- [18] Taiwan Economic Research Institute (2019). Assisting Small and Medium-Sized Enterprises to Develop Urban Innovation Ecosystems to Boost International Competitiveness. *Taiwan Economic Research Monthly*, 42(11), 6-7.
- [19] Taiwan Economics Editorial (2019), Building a strong and innovative power in the ecosystem. *Taiwan Economic Research Monthly*, January 2019, 6-7. <https://www.tier.org.tw/comment/tiermon201901.aspx>
- [20] Teece, D. J. (2007). Explicating dynamic capabilities: The nature and microfoundations of (sustainable) enterprise performance. *Strategic Management Journal*, 28(13), 1319-1350.
- [21] Wareham, J., Fox, P. B., & Cano Giner, J. L. (2014). Technology ecosystem governance. *Organization Science*, 25(4), 1195-1215.
- [22] West, J., & Wood, D. (2013). Evolving an open ecosystem: The rise and fall of the Symbian platform. *Advances in Strategic Management*, 30, 27-67. doi: 10.1108/S0742-3322(2013)0000030005.

Do Users Mind the Brand Engagement? The Effect of Brand Engagement in Knowledge Sharing Virtual Community

(Full Paper)

Xiaobei Liang, liangxiaobei@tongji.edu.cn

Ruohong Hao, 1930424@tongji.edu.cn

Hu Meng*, menghu@tongji.edu.cn

School of Economics and Management, Tongji University, China

ABSTRACT

Although previous studies have discussed antecedent mechanisms for user participation and the value it creates in the brand community. Few studies discuss the role of brands, communities, and users in the co-creation of value when virtual communities are established based on users' interests or needs. This paper explored the effect of brand participation on user community engagement intentions/behaviors in virtual communities. Data was collected from China by online survey and empirical analysis was used for hypotheses testing. The result shows that when brands participate in virtual communities, the higher the user's engagement intention, the easier it is for them to make knowledge contribution, which will promote the development and operation of virtual communities. What's more, in the context of brand participation, brand interactivity will affect the user's community engagement intention and thus the user's knowledge contribution, which will prompt the development of a virtual community. These findings confirmed that virtual community can help to implement circle marketing, interact with consumers, improve consumers' willingness to participate actively, and have positive practical significance for the government and firms.

Keywords: Virtual community, brand engagement, value co-creation, knowledge sharing.

*Corresponding author

INTRODUCTION

Virtual community is not the place only for consumers to share their thoughts and questions about brands (Muniz & O'Guinn, 2001), but a place for people to share knowledge or gather information (Chiu *et al.*, 2011). Users invest in focal resources in specific interactions, such as knowledge sharing, to realize their co-creation and interactive experience in the virtual community (Hollebeek, Juric, & Tang, 2017; Hollebeek, Srivastava, & Chen, 2019; Vargo & Lusch, 2016). According to past research, people are more concerned about the interaction between consumers and brands in the context of brand community and discussed what factors influenced user behavior in this type of virtual community. They believed that, compared with the unilateral communication of traditional media, brand communities can achieve consumer-brand interaction (Brodie, Ilic, Juric, & Hollebeek, 2013). In this interactive situation, consumers can not only spread brand-related information, such as Word-of-Mouth (Hollebeek & Chen, 2014), but also can generate their content (Hollebeek & Macky, 2019). In the process of brand interaction, users have invested a lot of resources and energy, and are willing to participate in the branding co-creation (Islam, Rahman, & Hollebeek Linda, 2017; Kaur, Paruthi, Islam, & Hollebeek, 2020). Prior researches more focused on the brand participation behavior of consumers in virtual community (Brodie, Hollebeek, Juric, & Ilic, 2011; Hollebeek *et al.*, 2017; Kaur *et al.*, 2020) while a few studies have focused on the influence of brand participation behavior itself. They discussed more on users' engagement in the context of the professional community (Chen, 2007; Chiu *et al.*, 2011; Hsu, Ju, Yen, & Chang, 2007), and focused more on the user's own behavior or intentions. That is to say that prior research paid less attention to the effect of brand engagement. What's more, the previous studies explored the relationship between consumers and brands, products, and other consumers in the online brand community (McAlexander, Schouten, & Koenig, 2002), or some antecedent mechanisms that influence user's participation (Tsai & Bagozzi, 2014; Wirtz *et al.*, 2013). However, the past researches have not taken the role of virtual community into consideration. Although the brand engages in the community is regarded as the guidance of consumer behavior, and discussed its influence on consumer participation behavior in the virtual community. However, in the knowledge-sharing community, the brand usually acts as a user to share their knowledge and put forward their questions. When brands act like community users, will consumers' community participation behavior be affected? Therefore, we believed that it is necessary and valuable to explore the effect of brand engagement on user behavior in the virtual community. The attempt of this study can not only expand the theoretical construction of how brand engagement affects user community engagement in the virtual community. From a practical perspective, it can also inspire brands which that want to obtain more user traffic from the virtual community and expand their customer base.

In addition, we also found that the interaction effect among user, brand and community when brand engages in the virtual community. The past researches stated that in the virtual community, the active participation of users can emerge benefits, such as

the realization of value co-creation between users and the community (Yen, Hsu, & Huang, 2011). Therefore, we would like to distinct that if brand, user and community can achieve value co-creation when brand involving the relationship between the virtual community and the user.

The possible contributions of this study are as follows: firstly, this study will explore the participation behavior of different types of users within the virtual community. Although scholars have a consensus on user types in the virtual community, there is still controversy over the contribution of different types of users to the virtual community. For example, some studies have found that lurkers do not generate content in the community, their presence is not conducive to the development of the virtual community as a result (Badreddine & Blount, 2019). However, it has been argued that although lurkers do not generate content, their reading behavior can facilitate the diffusion of knowledge and information (Antin, Cheshire, & Acm, 2010). Based on this, this study will further discuss whether different types of users can create value in their engagement from the perspective of value co-creation. Secondly, we will also analyze it from another view. That is, the effect of brand engagement on the value co-creation between community, brand and users in the virtual community which is formed by user interests or needs. While past researches on the virtual community have been discussed in terms of users, with little research revealing the role of community and brand mostly. Thirdly, most of the studies on user participation in the virtual community focused on the antecedents of user participation or the consequences of community engagement respectively. That is, users' virtual community engagement intentions or behaviors are treated as either independent or dependent variables. Few papers have discussed how the antecedents of user community engagement affect the outcomes. This study will try to dissect both the antecedents (user type) and the outcomes (value co-creation) of user engagement in the virtual community, enriching the theoretical extension.

Combined with the above considerations, this study will develop the hypotheses and theoretical model on the basis of the literature review of knowledge sharing in the context of the virtual community. Furthermore, the consumer data obtained from the experiment will be used for analysis and discussion later. Moreover, the theoretical and managerial implications will also be proposed to provide some references for other scholars or managers.

LITERATURE AND HYPOTHESES

Knowledge sharing plays a vital role in the development of the virtual community (Chiu, Hsu, & Wang, 2006; Zhang *et al.*, 2010). It is a critical factor to keeps the virtual community operate normally (Dholakia, Bagozzi, & Pearo, 2004). For example, Caterpillar has invested in building firm knowledge networks to facilitate knowledge sharing among employees, which ultimately achieving about 200% return on investment (Chiu *et al.*, 2011; Zhang *et al.*, 2010). In the past, the knowledge sharing behavior in the virtual community was mostly considered from the user's intrinsic motivation or social factors. Considering the internal motivation of user participation, self-expression and self-actualization affect the knowledge sharing behavior of users in the virtual community (Shao, 2009). In order to shape an individual's image, knowledge or experience is usually expressed to others through knowledge sharing in virtual communities. Studies have also shown that users are more willing to share knowledge, if they are confident that they can perform better and obtain a higher sense of self-efficacy from knowledge sharing (Hsu *et al.*, 2007). In addition, psychological safety is another vital factor that will influence users' knowledge sharing in the virtual community. When users perceived that it is safe to participate in a virtual community, they are more likely to express themselves, present themselves, and share their knowledge in a virtual community (Zhang *et al.*, 2010). From the perspective of social factors, social capital (Chang & Chuang, 2011; Wasko & Faraj, 2005), social interaction (Chen, 2007), social identity (Ma & Agarwal, 2007), user satisfaction with the community (Zhang *et al.*, 2010), and trust (Zhao, Wang, & Fan, 2015) will all have a significant effect on users' participation and knowledge sharing in the virtual community. While these studies illustrated which motivations for participation within virtual community's influence users' knowledge-sharing behaviors, it is limited to the participants themselves and does not consider the role of community or brand in these knowledge-sharing processes.

Knowledge sharing within the virtual community yields many outcomes. Past studies have suggested that brands can integrate knowledge within virtual communities to innovate new products (Tsai, Liao, & Hsu, 2015), improve operational efficiency (Revilla & Knoppen, 2015), enhance consumer contributions to collaborative product (Hollebeek & Chen, 2014). Also, for the community, users' participation in the community brings knowledge contributions (Chen, Yang, & Tang, 2013; Chou, Lin, & Huang, 2016) or spreads positive word of mouth (Mathwick, Wiertz, & De Ruyter, 2008). These studies suggested that it is necessary to promote the knowledge sharing behavior of users within the community, both for the community itself and for the brand. However, these studies only consider the contribution that user engagement behavior makes to community or brand development respectively. They do not consider the role of all three roles in value creation simultaneously. Therefore, we try to explore the role of the user, the brand, and the community simultaneously. What's more, we will also explore how the brand's intervention affects the user's intention to participate in the virtual community, and what value they create when all three work together.

Hence, we will next explore how brand engagement influences the knowledge-sharing behavior of different types of users, to achieve value co-creation between brands, users and the virtual community. It should be pointed out that the context of these discussions is a virtual community based on users' interests or needs.

User type

It plays an important role that the willingness of community members to participate, the information obtained and the content generated by others on the sustainable development of online communities (Fuller *et al.*, 2014). But different types of individuals have different willingness to participate in the virtual community (Akar & Mardikyan, 2018; Garnefeld, Iseke, & Krebs, 2012). According to user content generation behavior in knowledge sharing virtual community, users can be divided into two types: poster and lurker. The poster refers to the user who regularly logs into an online community and generates content for it, and has significant value to the ecosystem of the virtual community (Chen *et al.*, 2019). Most of the knowledge sharing content in the community is contributed by posters (van Mierlo, 2014). While lurkers always log in to the online community without any contribution of new content. Scholars take a different view of the contribution of lurkers to the virtual community. Some argued that lurkers do not generate content and that their actions undermine organizational civilization behavior in the community (Badreddine & Blount, 2019). However, some believed that although lurkers seem to be free-riders, their reading behavior has a positive effect on community development (Antin *et al.*, 2010). However, we believed that both posters and lurkers have different intention of community engagement. Compared to lurkers, posters share their knowledge to achieve a sense of self-worth (Bock, Zmud, Kim, & Lee, 2005), which could motivate them to engage in the virtual community. Thus, the following hypothesis is posited:

H1: Compared to lurkers, the poster has a positive intention of community engagement.

Value co-creation in virtual community

From a traditional product perspective, producers and consumers are separated. As the economy develops, people increasingly find that people are a critical factor in the consumption market. From a service-centric market perspective, consumers can always participate in value creation (Vargo & Lusch, 2004). In the process of interaction with consumers, the value co-creation of products or service are realized (Prahalad, 2004). The value co-creation is not limited to the interaction between the brand and the consumer, but different participants-suppliers, business partners, and allies- co-create value (Zhang *et al.*, 2020). Hence, we considered that when a brand engages in a virtual community, the co-creation of value will be generated between the user, the community and the brand.

User and Community. In a virtual community, value co-creation activities will bring the community economic or hedonic value. Members of the online healthy community can reduce the health care cost by various activities, which will generate economic value (Liu *et al.*, 2020). Users in the virtual community co-create the value with the community or other users by various activities. While the knowledge contribution and organizational citizenship behavior (Chen & Hung, 2010; Chiu *et al.*, 2011; Chou *et al.*, 2016; Dholakia *et al.*, 2004) were regarded as two typical and popular value co-creation behavior of users in the context of virtual community in the prior researches. Knowledge contribution was considered as an important user behavior, which can ensure the operation of the virtual community normal and organizational citizenship behaviors such as help and tolerance can maintain the order of the virtual community (Dholakia *et al.*, 2004).

Therefore, we believe that when brands engage in the virtual community through various activities, users' willingness to participate in the community is stronger. They are more inclined to share knowledge in virtual communities in order to maintain the community and ensure its normal operation, which will realize the value co-creation between users and the community.

User and Brand. Customer brand co-creation behavior is a customer-led interaction between customers and brands that assumes that customers are not passive purchasers of the brand, but that they actively participate in the creation of the brand experience (Prahalad & Ramaswamy, 2000; Vargo & Lusch, 2004). This brand co-creation behavior is mainly divided into direct creation and indirect creation, where direct value creation occurs directly between the customer and the brand and may include participation in an online competition for product improvement, and indirect value co-creation occurs indirectly between the customer and the brand and is a customer-led interaction that may include interaction with other customers, friends and family, and other networks (France, Merrilees, & Miller, 2015). By interacting with consumers in the virtual community, it helps brands to establish consumer loyalty for branding co-creation (Wang & Hajli, 2014). Thus, we suppose that:

H2: The intention of community engagement from different types of user, will influence (a) knowledge contribution, and (b) branding co-creation in the context of brand engagement in the virtual community.

Brand Engagement

Brand engagement refers to "A cognitive and affective commitment to an active relationship with the brand as personified by the website or other computer-mediated entities designed to communicate brand value" (Mollen & Wilson, 2010). Among them, brand interactivity is at the core of brand engagement, enhancing the effectiveness of brand engagement (Mangold & Faulds, 2009; Wirtz *et al.*, 2013). In the field of social media, brands engage in social media through different KOLs, thereby influencing consumer attitudes towards the brand (Hughes, Swaminathan, & Brooks, 2019). In the knowledge sharing virtual community, we regard

“brand engagement” as acting like a user. Thus, we believed that on the one hand, brand engagement enhances the interaction between the brand and users, which provides users with the power to share knowledge and promotes them to make knowledge contributions. On the other hand, brand interactivity can affect users' attitudes towards the brand, thereby encouraging them to spread the brand's positive word of mouth. That is:

H3: The brand interactivity will influence (a) knowledge contribution, and (b) branding co-creation by the users' community engagement, in the context of brand engagement in the virtual community.

Based on the above hypotheses, our research model is shown as Figure 1.

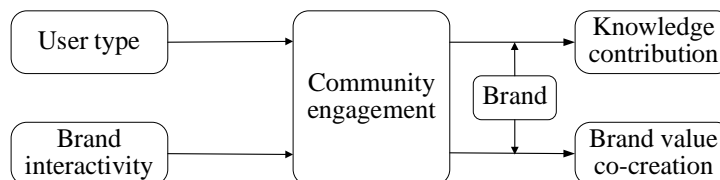

Figure 1: Theoretical model.

MEASUREMENT

Data collection

Participants. Data were collected from 73 participants from China through an online survey. There are 63 participants who provided usable information, representing a response rate of 86.3%. Among these remaining 63 participants, 10 are males and 53 are females. 49.2% are undergraduates and 49.2% are postgraduate. The degree of the remaining people is lower than the bachelor's degree. When asked whether to join into a virtual community ever before, 43 participants said yes and 31.7% of participants never participated in a virtual community.

Procedure and materials. We set two experimental scenarios with brand engagement (brand engagement: with brand vs. without brand), so as to explore whether and how brand engagement affects the intention of virtual community participation for different users and the value co-creation among users, communities and brands in the community ecology. Which that controlled other information was the same and asked participants to browse the virtual community set in the experiment and finish the questionnaires. In addition, to collect data better, we had conducted an online survey. On the one hand to provide a real experiment environment for the respondents- virtual communities are generally placing where users can perform activities online. On the other hand, more samples that meet the characteristics of netizens can be selected online, without being affected by the geographic location of the offline experiment which leads to large deviations in the experiment.

A knowledge-sharing virtual community is used for our experimental material. It is because that the content of knowledge sharing virtual community is mainly generated by users, and the knowledge sharing behavior of users will not be controlled by the brand. In a knowledge-sharing virtual community, brand participation can be regarded as an exogenous variable.

Each subject was randomly divided into two groups of experimental scenarios. Before the experiment, we will ask the subjects to imagine that they are browsing a knowledge sharing virtual community. Each subject was told as follows:

Imagine that you are browsing your favorite online virtual community and reading the following page (experiment scenarios). Then, please answer the following questions according to your real feelings.

Measures

All experimental questionnaire items were rated on a five-point Likert scale (1: strongly disagree, 5: strongly agree). All the details of the scale can be checked in Table 1.

User type. We believed that users in the virtual community can be divided into two types: Lurker and Posters. So that we included user type as a dummy variable: the type=1 if the respondent is a poster in the community and 0 if he/she is a lurker.

Community Engagement. We used the community engagement to measure the user's engagement intention in the virtual community. The four-item scale was developed by Algesheimer, Dholakia, and Herrmann (2005). A sample item from Community Engagement was “I benefit from following the virtual community's rules”. The Cronbach's alpha was 0.766.

Brand Interactivity. We used the Brand Interactivity to measure the users' perception of brand engagement in the virtual community. The three-item scale was developed by Cheung, Pires, Rosenberger, and De Oliverira (2020). A sample item from

Brand Interactivity was “The content about the brand X found in the virtual community seems interesting”. Cronbach’s alpha was 0.859 for brand interactivity.

Value Co-creation. We considered the value co-creation between users, brand and virtual community these three roles from both user-brand and user-community perspectives. Among these, user-community value co-creation is measured in terms of knowledge contribution. The three-item scale of Knowledge Contribution was developed by Hsu *et al.* (2007), Yi and Gong (2013), and Chou *et al.* (2016). A sample item from knowledge contribution was “I spend more time than I expected navigating the virtual community”. The Cronbach’s alpha was 0.7383. From the perspective of user and brand value co-creation, we used Branding Co-Creation to measure the value co-creation of customer and brand. A sample of branding co-creation was “I am willing to provide my experiences and suggestions when my friends want my advice on buying something from a brand I learned in the virtual community.”, which was decided by Wang and Hajli (2014). The Cronbach’s alpha was 0.915.

Table 1. Variables and their measures.

Variables	Measures
Community Engagement	I benefit from following the virtual community’s rules. I am motivated to participate in the virtual community’s activities because I feel better afterward. I am motivated to participate in the virtual community’s activities because I am able to support other members. I am motivated to participate in the virtual community’s activities because I am able to reach personal goals.
Brand Interactivity	The content about the brand X found in the virtual community seems interesting It is exciting to interact with brand X in the virtual community. It is fun to collect information on brand X in the virtual community.
Knowledge Contribution	I usually involve myself in discussions of various topics rather than specific topics. When discussing a complicated issue, I am usually involved in subsequent interactions. I said positive things about the virtual community to others.
Branding Co-Creation	I am willing to provide my experiences and suggestions when my friends want my advice on buying something from a brand I learned in the virtual community. I am willing to buy the products of a brand recommended by my friends in my favorite virtual community. I will consider the buying experiences of my friends in my favorite virtual community when I want to go for a brand I learned from the community.

RESULTS

Descriptive statistic

We concluded a confirmatory analysis (CFA) of a four-factor baseline model composed of community engagement, brand interactivity, knowledge sharing, and branding co-creation. The CFA results were shown in Table 2. We also performed rotational factor analysis and common method deviation analysis. The analysis results showed that the rotation factor load of each item of each factor is greater than 0.68. And Harman’s single factor test method tests the common variance, and the common method deviation of the questionnaire data is not serious.

Table 2. Model fitting results.

χ^2	df	p	χ^2/df	GFI	RMSEA	CFI	IFI
93.103	59	0.003	1.578	0.825	0.096	0.918	0.921

Table 3 listed the means, standard deviations and intercorrelation among variables in the experiment. Significantly, users’ type was correlated with community engagement ($r=.268$, $p<0.01$) only. Similarly, brand interactivity was correlated with community engagement ($r=.337$, $p<0.01$), knowledge contribution ($r=.327$, $p<0.01$) and brand co-creation ($r=.386$, $p<0.01$) respectively. In addition, the knowledge contribution was correlated with community engagement ($r=.319$, $p<0.05$) and brand interactivity ($r=.327$, $p<0.01$) respectively. The brand co-creation was correlated with community engagement ($r=.392$, $p<0.01$).

Table 3. Means, standard deviations, and intercorrelations.

Variables	Mean	SD	1	2	3	4	5	AVE	CR
UT	.508	.504	1						
CE	3.373	.707	.286*	1				0.484	0.775
BI	2.677	.863	.185	.337**	1			0.689	0.868
KC	3.191	.901	.150	.319*	.327**	1		0.563	0.777
BC	3.169	1.04	.172	.392**	.549**	.386**	1	0.792	0.919

Note: * $p<0.05$. ** $p<0.01$

Hypothesis Testing

We also examined the causal effect of different user types on their intention of community engagement. According to the different two types of users, we found that for the poster they have a positive intention to engage in the knowledge sharing community by ANOVA analysis ($p=0.023$). H1 was supported and the difference between two different types of users was presented in Figure 2.

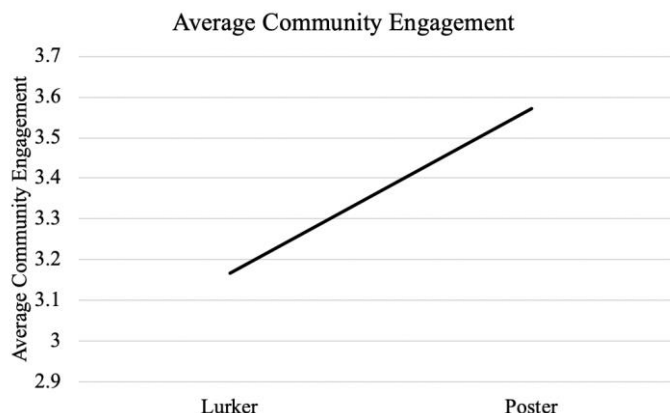

Figure 2. The Causal effect of user type on community engagement.

As for Hypothesis 2, we believed that when a brand engages in a virtual community, the intention of different users to participate will affect their knowledge contribution behavior and brand value co-creation. OLS method was used to test the hypothesis. According to results, we found that if we do not consider the influence of the brand, the influence of user type on their knowledge sharing behavior by community engagement intention is not significant (95% CI= [-1.836 .722] includes 0). However, when brands engage in the virtual community, the type of users will affect their intention to participate in the virtual community which will positively thus their knowledge contribution behavior (index of moderated mediation 95% CI= [.061 .999] excludes 0). So that the H2a was also supported. For H2b, we found that user types will affect their engagement intentions and the value co-creation behavior between them and the brand. However, the total effect of user type on brand value co-creation was not significant (total effect: 95% CI= [-.166 .875] includes 0; indirect effect: 95% CI= [.021 .534] excludes 0).

Table 4. The effect of user types on knowledge contribution and brand value co-creation.

Variables	Model 1	Model 2	Model 3	Model 4
	Knowledge Contribution		Brand Co-Creation	
User type	.115	-.007	.133	.064
Community Engagement	.383*	.500**	.004**	.583**
Brand		.048		.205
Brand × Community Engagement		.770*		.371
df	60	58	60	58
R ²	.106	.188	.157	.181

Note: * $p < .05$. ** $p < .01$.

When we considered the moderating effect of brand engagement, the interaction of brand and community engagement was not significant (index of moderated mediation 95% CI= [-.157 .862] includes 0). However, when the brand engages in the virtual community, the branding co-creation of different types of users is completely mediated by their intention to participate (95% CI= [.055 .942] excludes 0).

In Hypotheses 3, we argued that when brand engage in the virtual community, the brand interactivity will affect their behavior of knowledge sharing and brand value co-creation by their intention of community engagement. From Table 5, we also found that for the knowledge contribution behavior, the brand interactivity cannot promote people's value co-creation between users and the virtual community by affecting people's intention to engage. Although under the condition of a brand engagement, the interactivity of the brand can indirectly affect the user's knowledge contribution behavior through the user's intention to engage in the community (with the brand, the mediation 95% CI= [.085 .475] excludes 0), the moderation mediation is not significant (index of moderated mediation 95% CI= [-.045 .440] includes 0). Therefore, brand interactivity will influence the knowledge contribution by user's community engagement intention when the brand has already engaged in the virtual community. For brand value co-creation, the results showed that brand interactivity has a direct effect on brand value co-creation of users in the virtual community (95% CI= [.330 .824] excludes 0). When considered the engagement of the brand in the virtual community, we found that there was no significant evidence showing that the brand interactivity will affect the brand value co-creation by their intentions of community

engagement (Index of moderated mediation effects 95% CI= [-.217 .330] includes 0). Hence, the H3a was supported while H3b was not supported.

Table 5. The effect of brand interactivity on knowledge contribution and brand value co-creation.

Variables	Model 5	Model 6	Model 7	Model 8
	Knowledge Contribution	Knowledge Contribution	Brand Co-Creation	Brand Co-Creation
Brand Interactivity	.258	.183	.566***	.573***
Community Engagement	.301	.405*	.3431*	.308
Brand		.062		.253
Brand × Community Engagement		.644*		.003
df	60	58	60	58
R²	.114	.213	.349	.181

Note: *p < .05. **p < .01. ***p < 0.001

CONCLUSION

This paper focused on whether users will mind brand engagement in the virtual community. We explored how brand engagement affects the knowledge sharing behavior and brand value co-creation behavior of different types of users in the virtual community. Firstly, in the virtual community, different types of users have different intentions to engage. For the poster, the intention to participate in the virtual community is higher. In addition, when brands participate in virtual communities, different types of users will have different intentions to participate in the community, thereby promoting their knowledge contributions.

What's more, we also found that in the process of brand participation, interaction with the brand will positively affect the user's knowledge contribution by affecting the user's participation intention. Hence, we concluded that brand engagement in the virtual community will promote the knowledge sharing behavior of posters.

Theoretical Implication

This paper explored the effect of brand engagement on users' intention to engage, knowledge contribution behavior, and brand value co-creation in a knowledge-sharing virtual community. Firstly, the result confirmed that different types of users have different intentions to participate in the virtual community (Akar & Mardikyan, 2018). For active community users, they are more willing to participate in the virtual community. Because in the virtual community, the poster can participate to express themselves and realize themselves (Shao, 2009). In addition, this study also expanded the influence mechanism that affects users' intention of their community engagement. Prior researches have focused on exploring the antecedents or outcomes of participating behaviors (Chan, Zheng, Cheung, Lee, & Lee, 2014). However, this paper discussed the impact of user types on their intention to participate in the virtual community, and after the brand participates, the community engagement intention of different types of users affects their knowledge sharing with the community or the value co-creative behavior with the brand.

Secondly, this paper determined that brand engagement will positively influence people's knowledge contribution behavior, and filled the research gap about users' community engagement behavior in non-brand virtual communities. We found that when brands participate in a knowledge-sharing virtual community, the poster will show a more active intention to participate in the community and make knowledge contributions to promote the development and operation of the community. In addition, we also confirmed that in the context of brand participation, the willingness of posters to participate in the virtual community has a positive impact on brand value co-creation.

However, this paper had also reached inconsistent conclusions with past research on brand value co-creation. Although current researches have different opinions on the impact of brand engagement behavior, some people believed that brand engagement promotes the interaction between brands and consumers, and promotes brand-related investments in focus consumers. But some people believe that the negative word of mouth spread by consumers may reduce the others participation (Alexander, Jaakkola, & Hollebeek, 2018; Bowden *et al.*, 2017; Naumann, Bowden, & Gabbott, 2017). However, this study believed that the interactivity of brands will positively affect the value co-creation between users and brands in the context of virtual community. The higher the brand's interactivity, the easier it is for users to be converted into loyal users, and they are more willing to pass on the positive WOM of the brand to achieve co-creation of brand value. But this research did not get significant data results. It may be because the brand's participation in the experimental scene does not effectively affect the brand's interactivity.

Managerial Implication

The results of this paper have also positive implications for the brand influence of the currently popular non-brand community. Firstly, the results showed that users do not mind the participation of brands in knowledge-sharing communities. Even this brand participation behavior has a positive impact on promoting the operation of the virtual community. For brand managers, they can broaden the brand publicity channels to get closer to users through knowledge sharing and other behaviors, convert public domain

traffic in the virtual community into brand private domain traffic, and transform users in the virtual community into brand loyal users. Secondly, brands should pay more attention to the interaction with users in the virtual community. The research results of this paper showed that it is not the brands engagement that can have a positive impact on users' knowledge sharing behavior or brand value co-creation. Therefore, this article believed that brands should pay attention to participating in virtual communities. Thirdly, the research context of this research is a knowledge-sharing community. Users participating in this type of community prefer to collect information and share knowledge. The inspiration to managers is that in the future, brand marketing can focus on specific groups and adopt appropriate marketing activities according to the characteristics of different groups in the circle, such as LGBT groups.

Limitation and Further Research

Although this study confirmed that users do not mind brand engagement in knowledge-sharing communities, we believed that this study has some limitations. First, the amount of data in this study is relatively small, with only 63 valid test data. We believed that more participants can be invited to participate in our experiment in the future. In addition, there are still many questions about the relevant research on brand value co-creation in this article. Future research can focus on how brands interact with users in the virtual community to effectively affect their brand value co-creation. Another point, we think that the amount of data in this paper can be expanded. In the future, we can obtain data of the users' participation behavior in a knowledge-sharing virtual community in real-time, and the user's participation behavior can be confirmed through second-hand data.

ACKNOWLEDGMENT

This work was supported by the National Social Science Fund of China under Grant 20AZD059. The authors declare no conflict of interest.

REFERENCES

- [1] Akar, E., & Mardikyan, S. (2018). User roles and contribution patterns in online communities: a managerial perspective. *Sage Open*, 8(3), 2158244018794773. doi:10.1177/2158244018794773
- [2] Alexander, M. J., Jaakkola, E., & Hollebeek, L. D. (2018). Zooming out: actor engagement beyond the dyadic. *Journal of Service Management*, 29(3), 333-351. doi:10.1108/josm-08-2016-0237
- [3] Algesheimer, R., Dholakia, U. M., & Herrmann, A. (2005). The social influence of brand community: Evidence from European car clubs. *Journal of Marketing*, 69(3), 19-34. doi:10.1509/jmkg.69.3.19.66363
- [4] Antin, J., Cheshire, C., & Acm. (2010). *Readers are not free-riders: Reading as a form of participation on wikipedia*. Paper presented at the ACM Conference on Computer Supported Cooperative Work, Savannah, GA. <Go to ISI>://WOS:000286948800019
- [5] Badreddine, B. M., & Blount, Y. (2019). Understanding influential factors behind lurking behaviour in online cancer communities. *Behaviour & Information Technology*, 23. doi:10.1080/0144929x.2019.1709545
- [6] Bock, G. W., Zmud, R. W., Kim, Y. G., & Lee, J. N. (2005). Behavioral intention formation in knowledge sharing: Examining the roles of extrinsic motivators, social-psychological forces, and organizational climate. *MIS Quarterly*, 29(1), 87-111. doi:10.2307/25148669
- [7] Bowden, J. L. H., Conduit, J., Hollebeek, L. D., Luoma-aho, V., & Solem, B. A. (2017). Engagement valence duality and spillover effects in online brand communities. *Journal of Service Theory and Practice*, 27(4), 877-897. doi:10.1108/jstp-04-2016-0072
- [8] Brodie, R. J., Hollebeek, L. D., Juric, B., & Ilic, A. (2011). Customer engagement: conceptual domain, fundamental propositions, and implications for research. *Journal of Service Research*, 14(3), 252-271. doi:10.1177/1094670511411703
- [9] Brodie, R. J., Ilic, A., Juric, B., & Hollebeek, L. (2013). Consumer engagement in a virtual brand community: An exploratory analysis. *Journal of Business Research*, 66(1), 105-114. doi:10.1016/j.jbusres.2011.07.029
- [10] Chan, T. K. H., Zheng, X., Cheung, C. M. K., Lee, M. K. O., & Lee, Z. W. Y. (2014). Antecedents and consequences of customer engagement in online brand communities. *Journal of Marketing Analytics*, 2(2), 81-97. doi:10.1057/jma.2014.9
- [11] Chang, H. H., & Chuang, S. S. (2011). Social capital and individual motivations on knowledge sharing: Participant involvement as a moderator. *Information & Management*, 48(1), 9-18. doi:10.1016/j.im.2010.11.001
- [12] Chen, C. J., & Hung, S. W. (2010). To give or to receive? Factors influencing members' knowledge sharing and community promotion in professional virtual communities. *Information & Management*, 47(4), 226-236. doi:10.1016/j.im.2010.03.001
- [13] Chen, G. L., Yang, S. C., & Tang, S. M. (2013). Sense of virtual community and knowledge contribution in a P3 virtual community Motivation and experience. *Internet Research*, 23(1), 4-26. doi:10.1108/10662241311295755
- [14] Chen, I. Y. L. (2007). The factors influencing members' continuance intentions in professional virtual communities - a longitudinal study. *Journal of Information Science*, 33(4), 451-467. doi:10.1177/0165551506075323
- [15] Chen, X. Y., Li, X., Yao, D., & Zhou, Z. M. (2019). Seeking the support of the silent majority: are lurking users valuable to UGC platforms? *Journal of the Academy of Marketing Science*, 47(6), 986-1004. doi:10.1007/s11747-018-00624-8
- [16] Cheung, M. L., Pires, G., Rosenberger, P. J., & De Oliverira, M. J. (2020). Driving consumer-brand engagement and co-creation by brand interactivity. *Marketing Intelligence & Planning*, 38(4), 523-541. doi:10.1108/mip-12-2018-0587

- [17] Chiu, C. M., Hsu, M. H., & Wang, E. T. G. (2006). Understanding knowledge sharing in virtual communities: An integration of social capital and social cognitive theories. *Decision Support Systems*, 42(3), 1872-1888. doi:10.1016/j.dss.2006.04.001
- [18] Chiu, C. M., Wang, E. T. G., Shih, F. J., & Fan, Y. W. (2011). Understanding knowledge sharing in virtual communities An integration of expectancy disconfirmation and justice theories. *Online Information Review*, 35(1), 134-153. doi:10.1108/14684521111113623
- [19] Chou, E. Y., Lin, C. Y., & Huang, H. C. (2016). Fairness and devotion go far: Integrating online justice and value co-creation in virtual communities. *International Journal of Information Management*, 36(1), 60-72. doi:10.1016/j.ijinfomgt.2015.09.009
- [20] Dholakia, U. M., Bagozzi, R. P., & Pearo, L. K. (2004). A social influence model of consumer participation in network- and small-group-based virtual communities. *International Journal of Research in Marketing*, 21(3), 241-263. doi:10.1016/j.ijresmar.2003.12.004
- [21] France, C., Merrilees, B., & Miller, D. (2015). Customer brand co-creation: A conceptual model. *Marketing Intelligence & Planning*, 33(6), 848-864. doi:10.1108/mip-06-2014-0105
- [22] Fuller, J., Hutter, K., Hautz, J., & Matzler, K. (2014). User roles and contributions in innovation-contest communities. *Journal of Management Information Systems*, 31(1), 273-307. doi:10.2753/mis0742-1222310111
- [23] Garnefeld, I., Iseke, A., & Krebs, A. (2012). Explicit incentives in online communities: boon or bane? *International Journal of Electronic Commerce*, 17(1), 11-37. doi:10.2753/jec1086-4415170101
- [24] Hollebeek, L. D., & Chen, T. (2014). Exploring positively- versus negatively-valenced brand engagement: a conceptual model. *Journal of Product & Brand Management*, 23(1), 62-74. doi:10.1108/JPBM-06-2013-0332
- [25] Hollebeek, L. D., Juric, B., & Tang, W. Y. (2017). Virtual brand community engagement practices: a refined typology and model. *Journal of Services Marketing*, 31(3), 204-217. doi:10.1108/jsm-01-2016-0006
- [26] Hollebeek, L. D., & Macky, K. (2019). Digital content marketing's role in fostering consumer engagement, trust, and value: framework, fundamental propositions, and implications. *Journal of Interactive Marketing*, 45, 27-41. doi:10.1016/j.intmar.2018.07.003
- [27] Hollebeek, L. D., Srivastava, R. K., & Chen, T. (2019). S-D logic-informed customer engagement: integrative framework, revised fundamental propositions, and application to CRM. *Journal of the Academy of Marketing Science*, 47(1), 161-185. doi:10.1007/s11747-016-0494-5
- [28] Hsu, M. H., Ju, T. L., Yen, C. H., & Chang, C. M. (2007). Knowledge sharing behavior in virtual communities: The relationship between trust, self-efficacy, and outcome expectations. *International Journal of Human-Computer Studies*, 65(2), 153-169. doi:10.1016/j.ijhcs.2006.09.003
- [29] Hughes, C., Swaminathan, V., & Brooks, G. (2019). Driving brand engagement through online social influencers: an empirical investigation of sponsored blogging campaigns. *Journal of Marketing*, 83(5), 78-96. doi:10.1177/0022242919854374
- [30] Islam, J., Rahman, Z., & Hollebeek Linda, D. (2017). Personality factors as predictors of online consumer engagement: an empirical investigation. *Marketing Intelligence & Planning*, 35(4), 510-528. doi:10.1108/MIP-10-2016-0193
- [31] Kaur, H., Paruthi, M., Islam, J., & Hollebeek, L. D. (2020). The role of brand community identification and reward on consumer brand engagement and brand loyalty in virtual brand communities. *Telematics and Informatics*, 46, 12. doi:10.1016/j.tele.2019.101321
- [32] Liu, S., Xiao, W. Y., Fang, C., Zhang, X., & Lin, J. B. (2020). Social support, belongingness, and value co-creation behaviors in online health communities. *Telematics and Informatics*, 50, 18. doi:10.1016/j.tele.2020.101398
- [33] Ma, M., & Agarwal, R. (2007). Through a glass darkly: Information technology design, identity verification, and knowledge contribution in Online communities. *Information Systems Research*, 18(1), 42-67. doi:10.1287/isre.1070.0113
- [34] Mangold, W. G., & Faulds, D. J. (2009). Social media: The new hybrid element of the promotion mix. *Business Horizons*, 52(4), 357-365. doi:10.1016/j.bushor.2009.03.002
- [35] Mathwick, C., Wiertz, C., & De Ruyter, K. (2008). Social capital production in a virtual P3 community. *Journal of Consumer Research*, 34(6), 832-849. doi:10.1086/523291
- [36] McAlexander, J. H., Schouten, J. W., & Koenig, H. F. (2002). Building brand community. *Journal of Marketing*, 66(1), 38-54. doi:10.1509/jmkg.66.1.38.18451
- [37] Mollen, A., & Wilson, H. (2010). Engagement, telepresence and interactivity in online consumer experience: Reconciling scholastic and managerial perspectives. *Journal of Business Research*, 63(9-10), 919-925. doi:10.1016/j.jbusres.2009.05.014
- [38] Muniz, A. M., & O'Guinn, T. C. (2001). Brand community. *Journal of Consumer Research*, 27(4), 412-432. doi:10.1086/319618
- [39] Naumann, K., Bowden, J., & Gabbott, M. (2017). A multi-valenced perspective on consumer engagement within a social service. *Journal of Marketing Theory and Practice*, 25(2), 171-188. doi:10.1080/10696679.2016.1270772
- [40] Prahalad, C. K. (2004). The future of competition: Co-creating unique value with customers. *Research-Technology Management*, 47(3), 62-62.
- [41] Prahalad, C. K., & Ramaswamy, V. (2000). Co-opting customer competence. *Harvard Business Review*, 78(1), 79-+.
- [42] Revilla, E., & Knoppen, D. (2015). Building knowledge integration in buyer-supplier relationships The critical role of strategic supply management and trust. *International Journal of Operations & Production Management*, 35(10), 1408-1436. doi:10.1108/ijopm-01-2014-0030

- [43] Shao, G. S. (2009). Understanding the appeal of user-generated media: a uses and gratification perspective. *Internet Research*, 19(1), 7-25. doi:10.1108/10662240910927795
- [44] Tsai, H. T., & Bagozzi, R. P. (2014). Contribution behavior in virtual communities: Cognitive, emotional, and social influences. *Mis Quarterly*, 38(1), 143-+. doi:10.25300/misq/2014/38.1.07
- [45] Tsai, K. H., Liao, Y. C., & Hsu, T. T. (2015). Does the use of knowledge integration mechanisms enhance product innovativeness? *Industrial Marketing Management*, 46, 214-223. doi:10.1016/j.indmarman.2015.02.030
- [46] van Mierlo, T. (2014). The 1% rule in four digital health social networks: An observational study. *Journal of Medical Internet Research*, 16(2), 9. doi:10.2196/jmir.2966
- [47] Vargo, S. L., & Lusch, R. F. (2004). Evolving to a new dominant logic for marketing. *Journal of Marketing*, 68(1), 1-17. doi:10.1509/jmkg.68.1.1.24036
- [48] Vargo, S. L., & Lusch, R. F. (2016). Institutions and axioms: An extension and update of service-dominant logic. *Journal of the Academy of Marketing Science*, 44(1), 5-23. doi:10.1007/s11747-015-0456-3
- [49] Wang, Y., & Hajli, M. (2014). Co-creation in branding through social commerce: The role of social support, relationship quality and privacy concerns. *Social ence Electronic Publishing*.
- [50] Wasko, M. M., & Faraj, S. (2005). Why should I share? Examining social capital and knowledge contribution in electronic networks of practice. *MIS Quarterly*, 29(1), 35-57. doi:10.2307/25148667
- [51] Wirtz, J., den Ambtman, A., Bloemer, J., Horvath, C., Ramaseshan, B., van de Klundert, J., . . . Kandampully, J. (2013). Managing brands and customer engagement in online brand communities. *Journal of Service Management*, 24(3), 223-244. doi:10.1108/09564231311326978
- [52] Yen, H. R., Hsu, S. H. Y., & Huang, C. Y. (2011). Good soldiers on the web: Understanding the drivers of participation in online communities of consumption. *International Journal of Electronic Commerce*, 15(4), 89-120. doi:10.2753/jec1086-4415150403
- [53] Yi, Y., & Gong, T. (2013). Customer value co-creation behavior: Scale development and validation. *Journal of Business Research*, 66(9), 1279-1284. doi:10.1016/j.jbusres.2012.02.026
- [54] Zhang, T. T., Lu, C., Tones, E., & Cobanoglu, C. (2020). Value co-creation and technological progression: a critical review. *European Business Review*, 32(4), 687-707. doi:10.1108/eb-08-2019-0149
- [55] Zhang, Y. X., Fang, Y. L., Wei, K. K., & Chen, H. P. (2010). Exploring the role of psychological safety in promoting the intention to continue sharing knowledge in virtual communities. *International Journal of Information Management*, 30(5), 425-436. doi:10.1016/j.ijinfomgt.2010.02.003
- [56] Zhao, J., Wang, T., & Fan, X. C. (2015). Patient value co-creation in online health communities Social identity effects on customer knowledge contributions and membership continuance intentions in online health communities. *Journal of Service Management*, 26(1), 72-96. doi:10.1108/josm-12-2013-0344

Does COO really Matter in Value Co-Creation of Cross-Border E-Commerce?

(Full Paper)

Yan Ni*, Hubei Academy of Social Science, China, anne_hubei@foxmail.com

Zhen Qin*, Huazhong Agricultural University, China, qzwuhan@mail.hzau.edu.cn

Shumin Lv, Hubei Academy of Social Science, China, 2752928838@qq.com

ABSTRACT

The purpose of this paper is to explore the cross-border e-commerce value co-creation mechanism. We believe that the most significant factor affecting consumers' cross-border online shopping is online service quality. And the country of origin(COO) effect also plays an important role in the cross-border purchase intention. Therefore, this study built a proposed model of cross-border online purchase intention based on co-create theory and two-side market theory. For the case of online cross-border shopping, perceived value is very important which can directly determine the purchase intention of customers. Based on the related theory, three significant latent variables that can indirectly determine the purchase intention of customers as follows: consumer resource, platform service quality (or ESQ), and country of origin. According to our positive study, platform service quality is the most important factor, COO is the second one, and consumer expertise is the last one. All of the antecedent variables are significant according to statistical results. Then we made the conclusions and implications.

Keywords: COO, two-side market, value co-create, SEM, CMV.

*Corresponding author

INTRODUCTION

Despite recent trade frictions, those hopes have been borne out, with cross-border e-commerce sales through Amazon now raking in \$10, 000 a day on average. Under the background of the rapid development of information technology, e-commerce has become an important driver for the development of the world economy and has drawn great attention from various countries. China's e-commerce has a significant scale advantage in the world. As an important business model and trade method, cross-border e-commerce has become a new engine to promote the stable growth of foreign trade, promote the transformation and upgrading of foreign trade, and promote the overall economic development. Actively participating in and leading the development of international e-commerce rules has become an important strategic task in China's foreign trade field. In the future, digital trade will become the mainstream of international trade commerce, while traditional agriculture and manufacturing will benefit from this. Therefore, how to build a healthy and sustainable cross-border e-commerce value co-creation mechanism is of great significance (Gomez-Herrera, Martens & Turlea, 2014).

In recent years, value co-creation in the two-side market has become the focus of current theoretical and practical research. As the market competition environment changes, the role of customers in value creation has changed. Value is no longer created by the company alone, but is created by the interaction between the company and the customer through the internet platforms. Many domestic companies have achieved strong market competitive advantages through value co-creation. With the development of the network economy, the perspective of value co-creation has shifted from the dual interaction of enterprises and customers to the dynamic network interaction of multiple socio-economic participants.

Value co-creation in the two-side market is a new value creation model, and the influence mechanism of customer resources on the value co-creation ability has gradually attracted the attention of scholars and managers. In the S-D logic, the customer is the main body of value creation, and its role has changed from the passive participant to the dominant creator (Ng, Sweeney & Plewa, 2019). But in the two-side market, the platforms also played a significant role in the value co-created process. And there is less research on the value co-creation ability based on the two-side market, especially in cross border e-commerce market.

CONCEPTUAL BACKGROUND

Consumer Resource

In the case of shopping, consumers take advantage of relevant information previously stored in their brains (e.g., prior knowledge) and compare it to external sources of information search encountered when buying (Underwood, Klein & Burke, 2001). Consumer-related information about consumption products or services in brain memory, also known as consumer expertise (consumer expertise. At this time, consumers will rely less on external information, and instead, make consumption decisions based on their knowledge. When consumers can make consumption decisions, they will rely on their professional knowledge to connect with the external information of the product or service, comprehensively judge the effective filtering of external invalid information, and speed up the consumption decision. However, if consumers have almost prior knowledge,

their brain's ability to process attribute information of products or services will be reduced. Consumers' ability to process information about a product or service depends on how hard they work and their innate ability. The evaluation of the value of an online product or service depends on the consumer's recognition ability and prior knowledge, etc., which varies from person to person (Alba & Chattopadhyay, 1985).

Despite these results, as far as the authors are known, previous literature has not specifically emphasized that the level of consumer expertise can influence online consumption. This study assumes that consumer expertise will play a significant role in the valuation process of online purchasing of products or services.

Under the S-D logic theory, separated resources cannot create value. The value can be created only under the specific conditions of each resource's interaction and integration (Vargo & Lusch, 2008). Therefore, the S-D logic theory believes that consumers and enterprises can improve their situation and co-create value through resource integration. Traditional tangible product producers' single value creation theory is inconsistent with reality now. Even in the traditional tangible product industry, customers and companies are valued co-creation participants, and customers have a dominant position in presenting value propositions. The customers are unique value creators, and companies are only participants of value creation (Grönroos & Gummerus, 2014).

Arnould (2006) first proposed the concept of consumer resources, personal knowledge, technology, and social resources. Vargo and Lusch (2011) adopted a systemic view of value co-creation and reconstructs the concept of consumer resources. Expertise is based on cognitive structure and cognitive processes, which is the ability to perform product-related tasks (Alba & Hutchinson, 1987). There are five dimensions of consumer expertise as follows: cognitive effort, cognitive structure, analytical ability, advancement, and memory. Compared with newcomers, experts have stronger expertise. S-D logic theory argues that consumer expertise is the core of consumer-resource variables. Consumer expertise has a significant impact on consumers' collection and understanding of product or service information and psychological valuation of product and brand, as well as the consumer decision-making behavior.

However, nowadays the situation has been dramatically changed in two-side market. Companies have the opportunity to participate in value creation only by interacting with customers through online platforms, especially in cross-border e-commerce. Customers can obtain new resources in the service exchange system and integrate them into existing resources. In the process of resource integration, the value can be created. This study assumes that the cross-border e-commerce platform is the central hub for customers and companies to integrate resources and create value together.

Firm Resource

Not surprisingly, more and more research literature has developed the ESQ (electronic service quality) scale for e-commerce platforms and studied its relationship with consumer satisfaction, trust, and loyalty. However, the researchers also acknowledge that the nature and strength of the relationship between ESQ and loyalty vary from the context with differences between different cultures, different product categories, and different websites (Gupta, Reetika & Kabadayi, 2010). Therefore, it is important to further study the antecedents of the loyalty of electronic service platforms in different experience environments. Another research direction focuses on the conceptual definition and measurement of key dimensions of ESQ and the development of reflective and informative items of scales (Fassnacht, Martin & Koese, 2006). Moreover, many key unsolved issues have increased the importance of ESQ research. This study will contribute to the theory gap of cross-border e-commerce platform research based on co-create theory and two-side market theory.

Regarding the definition of ESQ, "the extent to which an online platform promotes effective and effective shopping, purchasing, and delivering products and services" was issued (Zeithaml *et al.*, 2002). And "the quality of network platform services is the degree to which network services can effectively and efficiently meet the needs of relevant customers" is more widely accepted, but still has some shortcomings. Therefore, in the context of our research, we define ESQ as the existing users' perception of the overall quality of the online platform.

Madhavaram and Hunt proposed the concept of operational resources in the form of corporate knowledge, technology, and innovation. And they did not make a further comprehensive systematic explanation of high-level enterprise resources variable, nor did they make a discussion from the perspective of e-commerce service quality (ESQ). ESQ is regarded as a significant factor for the success of Internet-based business models such as e-commerce platforms. It requires the full interaction and integration of various basic resources to form a joint force. ESQ's main factor is the enterprise resource. Higher-order enterprise resource is formed in a variety of collaborative tangible and intangible resources, such as market-oriented capabilities, power of pricing to market, consumer feedback response capability (Barrutia, Paredes & Echebarria, 2016).

The specific dimensions of ESQ are still controversial in the following aspects. First, some scholars believe that some of the original dimensions should be proposed, or new dimensions should be added. The two most controversial dimensions are system effectiveness and privacy. In empirical research, its explanatory power is weak, and the dimension of system effectiveness need not be considered. Moreover, e-commerce platform design and information have a significant impact on

ESQ (Fassnacht & Koese, 2006).

Second, In the process of e-commerce consumption, customers and suppliers are geographically separated, that is, customers cannot experience the goods before purchasing. This will lead to an increased probability of inconsistencies between e-commerce consumption results and consumption expectations (increasing quality uncertainty of the results). The probability that the customer's online consumption perception and the post-purchase consumption experience are significantly different increases (Collier & Bienstock, 2006).

Traditional ESQ definition After the rapid development of information technology and the evolution of consumer professional knowledge systems, traditional theories have fallen far behind reality, so ESQ should be redefined. The six dimensions of ESQ are as follows: security, reliability, page design, customer service, information volume, and customization (Theodosiou *et al.*, 2019). Quality is a key element of business success, and service quality is the customer's overall assessment of a customer's specific service. It is derived by comparing the performance of the company with the customer's general expectations of how the company in the industry should perform. Service quality plays a vital role in achieving companies' goals, including building trust, increasing satisfaction, and fostering loyalty, which are considered key factors for a company's competitiveness and success. Therefore, even though the service quality has been extensively studied in the traditional enterprise service environment, some standards for measurement have been changed. It is very important to study the new ESQ in the two-side market value co-create process. Finally, our study uses 3 dimensions to measure the ESQ, namely the platform service quality in this research.

COO

The effect of Country of origin (COO) is that are affected by stereotypes about that country and its products and services when consumers consider purchasing products or services from another country. COO can increase or decrease associations with individual products and brands (Suh, Hur & Davies, 2016). This study intends to conduct an empirical analysis of the country of origin effect of consumers purchasing foreign products on cross-border e-commerce platforms. The basis is the theory of stereotype (Hilton & Hoppel, 1996) and theory of positioning (Davies & Harré, 1990).

A national image (CI) is formed when a consumer's overall stereotype image of a particular country as a representative of a product or brand. This is based on the consumer's previous recognition of the advantages and disadvantages of a country or region's production and marketing. Consumers generate general views and opinions on products and services from this particular country. The impression is the result of a combination of the country's representative products, national characteristics, and political and economic environment. Each country has a unique national image in consumer perception. The national image can reflect both the advantages and disadvantages of the product or brand, and it may affect consumers' attitudes to the products of the country of origin. Consumers will expect products or services from technology-developed countries to be of higher quality and more reliable. In contrast, the national image of developing countries is often low quality, cheap, and not durable. Dichter(1962)first proposed the concept of COO. Country-of-origin effect generally means that consumers' value evaluation of a country's products or services or consumption intention is affected by consumers' stereotypes about the country, while country image (CI) generally refers to increased consumer willingness to buy (Correia & Kaufmann, 2017).

The impact of COO is important for countries that need to increase exports of manufactured goods (especially for resource-poor developing countries) and for companies purchasing products in different countries. First, the country of origin effect affects consumers' assessment of product quality, and ultimately affects their purchase possibilities and their willingness to pay. First, when consumers are unfamiliar with the product, they use the national image as a reminder. Second, when consumers are familiar with the product, they use the image to summarize their impression of the product in the country of origin and directly affect their attitude towards the product (Bhamjee, 2019). Based on the above discussion, this study uses COO as one of the independent variables.

Perceived Value

Consumer's perceived value refers to the overall evaluation of the effectiveness of the product or service obtained. Consumer's perceived value is S-D Logic result of the integration of consumers and enterprise resources. The above proposal is based on the S-D Logic. Value is perceived and determined by the beneficiaries. It is unique and phenomenological in the two-side market context, the concept of consumer perceives value can be divided by the significant factors which can affect customers, such as convenience, currency value, effort, and timeliness (Mpinganjira & Maduku., 2019).

Perceived value is defined as the overall assessment of the customers' utility of products and services. This study believes that consumer perceived value is the result of service and service encounters on the basis of value co-creation after enterprises and consumers have integrated their respective resources. Therefore, in this study, value is related to consumer perception in specific contexts. This view is consistent with the perspective of service science, and the value is always determined by the beneficiary based solely on phenomenology (Peng *et al.*, 2019). Then we measure perceived value with four items: convenience, cost performance, effort, and timeliness. These items are all based on the two-side market theory.

Purchase Intention

The willingness to buy online reflects the desire of customers to buy over the Internet. It is generally believed that when e-commerce websites or mobile applications provide shoppers with satisfactory services, consumers are more likely to purchase goods or services from virtual online stores. These services include product/service directories, search functions, online-trust, price comparison service, shopping cart service, online payment system, etc. (Grewal & Stephen, 2019). Therefore, considering the importance of each service in attracting consumers online, purchase intention is the psychological result of a particular behavior when a consumer decides to purchase a product or service. (Qin, Zhao & Ni, 2019) In terms of personality, the two main determinants of willingness to buy are as follows: customer attitudes and subjective norms. Online shopping willingness is the direction in which consumers tend to have specific behaviors in specific contexts (ie, online virtual stores). Combining the personality traits of internet users with their online technology cognition can better understand consumers' online shopping behavior (Frik & Mittone, 2019). On the basis of previous papers, this study combined with expert suggestions to give online purchase willingness items.

HYPOTHESIS DEVELOPMENT

Consumer Expertise is the Antecedent of Perceived Value

There are two differences between primary consumers and senior consumers: first, the knowledge structure is different; second, they use different knowledge in searching and choosing tasks and decision-making behaviors. Compared with novices, senior consumers know more about product categories, their cognitive structure is richer, and they are organized around more information. In an e-commerce environment, consumers have many choices, and consumers who lack the necessary knowledge and technology will be a loser at first. However, consumers with certain experience and knowledge can complete the purchasing task faster and more effectively through the e-commerce platform. Experienced customers get more value because they spend less energy (and cognitive effort) during the purchase process and can make better decisions. From a cost and workload perspective, experienced customers can perform online shopping tasks faster and easier. Moreover, experienced customers will better understand the meaning of product information and make informed decisions. Therefore, we assume:

H1: Consumer expertise will have a significant positive impact on consumers' perceived value.

Platform Service Quality is the Antecedent of Perceived Value

As mentioned in the previous section, this study takes the platform service quality as electronic-service quality. Cross-border e-commerce research shows that there is a positive correlation between the ESQ construct and customer value perception. Based on online interactive processes, e-commerce terminal descriptions of products or services, and logistics, the consumer can assess the perceived value of online shopping. We, therefore, propose the second hypothesis as follows.

H2: The quality of the platform service has a significant positive impact on the perceived value of consumers.

COO is the Antecedent of Perceived Value

The country of origin effect affects consumers' assessment of product quality, and ultimately affects their purchase possibilities and their "willingness to pay." First, when consumers are unfamiliar with the product, they use the national image as a reminder. When consumers are familiar with the product, they use the image to summarize their impression of the product in the country of origin and directly affect their attitude towards the product. In this study, the third hypothesis as proposed as followed,

H3: The COO has a significant positive impact on the perceived value of consumers.

The Mediation Effect of Perceived Value between the Antecedents and Purchase Intention

From a utilitarian perspective, perceived value is a trade-off between a bundle of benefits that buyers get. Given the intense competition and lower entry and exit barriers on the Internet, it is essential to study purchase intentions. We adopt this view and extend it by incorporating the effect of the above constructs as antecedents of perceived value. Therefore, we expect that:

H4: In two-side markets, the perceived value of a purchase is directly related to the willingness to buy; the higher the level of perceived value, the higher the level of willingness to buy.

H5: In two-side markets, there is the full mediation effect of perceived value between the antecedents and purchase intention

DATA COLLECTION AND RESEARCH METHODOLOGY

We developed preliminary measurement items and questionnaires based on previous research literature, and then made appropriate modifications under the guidance of experts based on the actual environment of this study. The purpose of the questionnaire is to analyze the impact of consumer resources, platform resources, and country of origin on consumer online shopping willingness under the value co-creation theory.

This research involves the collection of data about online cross-border purchase questionnaires. The study population is online cross-border shoppers in China. We use truncated sampling techniques to collect data. The sample size is calculated based on a 95% confidence level. According to the latest National Economic and Social Development Statistical Bulletin of Wuhan, Beijing, Shanghai, Guangzhou, and Shenzhen, Using those cities' population. According to the method of Frik & Mittone(2019): $n = N / (1 + Ne^2)$, at the significance of 5%, a survey sample size of 400 or more should be selected. Therefore, this study selected 525 samples in Beijing, Shanghai, Guangzhou, Shenzhen, and Wuhan based on sampling techniques. There were 469 valid samples, and the effective rate was 89.33%.

This study then used the social science statistical software packages SPSS22, AMOS22 and R to analyze the data. Perform descriptive statistical analysis, common method variation test, exploratory factor analysis (EFA), and confirmatory factor analysis (CFA) to identify latent variables (factors), Cronbach's alpha reliability test, composite reliability test, convergent validity test, and discriminant validity test. Finally, the mediating effects and the structural equation model were calculated.

Consistent with previous literature, our measurement of e-commerce platform service quality concepts includes multiple angles. Moreover, we use a second-order technique to build the construct. More specifically, the quality of e-commerce platform service is calculated as a second-order construct composed of dimensions of efficiency, design, and information accuracy.

For the measurement of consumer resources, we adopted the four-dimensional measurement standards proposed by Alba and Hutchinson, including cognitive effort, analysis, elaboration, and memory. We used these scales in combination with expert advices to adapt to new cross-border e-commerce scenarios.

In this study, various constructs in the more mature scale measurement models are selected. In order to ensure the validity of the questionnaire, each scale uses backward translation and contextualization methods to determine the description of each question. At the same time, the initial questionnaire for the study was formulated using cross-border e-commerce platform customer group interviews, etc. Based on the results of the pre-survey, combined with in-depth interviews with the experts, the questionnaire was further adjusted to form the final questionnaire for this study. The Likert five-point scale measures from the strongest disagreement to the strongest agreement with values from 1 to 5.

The research framework is shown in figure 1 as follows,

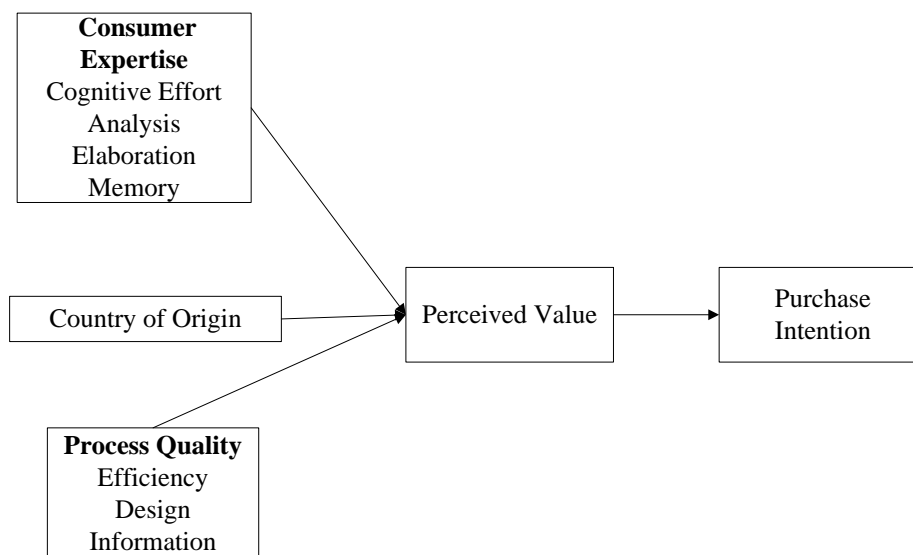

Figure 1: Research framework

EMPIRICAL RESULTS

Demographic Characteristics of the Sample

In this study, a total of 525 samples were collected from Chinese consumers. After removing invalid questionnaires such as incomplete filling and repeated filling, there were 469 valid samples, and the effective rate of collection was 89.33%. The descriptive analysis results of the Respondents were as follows: females accounted for 70.1%, males 29.9%, with a mean of

1.70 and a standard deviation of 0.49. Respondents had an average age of 35.61, a standard deviation of 3.63, and a mean cut-off of 35.19. Income is a categorical variable, with a mean of 3.95, a standard deviation of 0.39, and a tail-cut mean of 4.01. Respondents' educational background was classified as a categorical variable: junior high school or below, high school or junior high school, junior college, undergraduate, graduate, and above. The average educational background was 3.96, the standard deviation was 0.72, and the cut-off average was 3.79.

Table 1: Descriptive demographics of sample

Variable	n	mean	standard deviation	trimmed	min	max
Gender	469	1.70	0.49	1.75	1	2
Age	469	35.61	3.63	35.19	18	65
Education	469	3.95	0.39	4.01	1	5
Income	469	3.96	0.72	3.79	1	6

The Test and Control of Common Method Variance

The survey data was collected from July to August in 2019, and the respondents were located in Wuhan, Shanghai, Guangzhou, Shenzhen, and Beijing. The specific collection method is as follows: design and produce an electronic version of the questionnaire star website (<https://www.wjx.cn>). Through acquaintance relationships, teacher-student relationships, and campus-enterprise partnerships, we used WeChat electronic cash rewards to let their friends fill out online questionnaires. And we can use a special technique to identify the location of the respondents. For the sake of occurring probability of the common method variance in the study, the following methods were used in the process of questionnaire data collection for process control: First, the study used anonymous filling methods to allow respondents to fill in with confidence. Secondly, acquaintances who are directly looking for are not allowed to issue questionnaires in their work department or study class, to avoid suspicion of the interviewees that may affect the quality of the survey. Then, the respondents were asked to report whether they had seen or filled out this questionnaire before. This solution can avoid one person repeatedly filling in due to acquaintance relationships. Finally, there is no minimum requirement for the facilitator to collect questionnaire copies, so as not to put pressure on them.

Moreover, this study also uses statistical methods to test common method variation. Our study performed a Harman one-way test. The basic assumption of this technique is that if the common method variation problem is serious, when factor analysis is performed, either a single factor or a common factor accounts for most of the variable variation would be analyzed. If only one factor is isolated or a certain factor has great explanatory power, it can be determined that there is a serious common method variation problem. In this study, Harman's single factor test was performed first, and it was found that under the condition of no rotation, the variance (25.26) of the first principal component explanation of factor analysis did not account for the half (64.58%) of the total variance, which was less than the critical criterion. This shows that the common method deviation problem of this study is not obvious.

But it is only a diagnostic technique to evaluate the severity of the common method variation, and it is an insensitive test method, which does not have any effect to control the method effect. Therefore, the first common factor that has not been rotated is separated by exploratory factor analysis, and then the partial common relationship between the first common factor variable and the effect standard variable is calculated, and it is compared with the correlation coefficient of each variable of the original model. If the originally significant correlation coefficients are still significant, the effect of common method variation can be ignored. After analyzing the above steps, it was found that the variation of the common method in this study was not significant.

Table 2: Correlation coefficient matrix

Variable	(1)	(2)	(3)	(4)	(5)	(6)	(7)	(8)	(9)	(10)
Cognitive effort	0.773									
Analysis	0.349	0.654								
Elaboration	0.586	0.542	0.759							
Memory	0.451	0.594	0.448	0.732						
Efficiency	0.385	0.541	0.673	0.624	0.735					
Design	0.485	0.482	0.591	0.640	0.765	0.715				
Information	0.503	0.453	0.626	0.697	0.620	0.769	0.852			
COO	0.347	0.354	0.477	0.463	0.262	0.283	0.404	0.789		
Perceived value	0.417	0.492	0.641	0.607	0.505	0.467	0.555	0.365	0.757	
Purchase intention	0.559	0.619	0.659	0.614	0.677	0.625	0.644	0.489	0.574	0.686

Exploratory Factor Analysis

We employed the EFA first, the results are as followed in Table 3. Reliability and validity tests are very important for latent variable analysis. The Cronbach's alpha coefficient calculated by reliability analysis can measure the degree of internal consistency. If the Cronbach's alpha coefficient is between 0.6 and 0.8, the factor load should be 0.5 or higher, and the results at this time are credible. If the alpha coefficient value exceeds 0.8, it is more believable. Reliability results show that all variable values are reliable.

Validity testing is done through exploratory factor analysis. Exploratory factor analysis is considered as an important tool for the study of latent variable models. As shown, all factor loadings are above 0.5. The KMO value, which measures the adequacy of sampling, is higher than 0.6. The chi-square statistic value is significant at the level of 0.001. Therefore, the test results of this model show that all variables are valid and can be further analyzed.

Table 3: Exploratory factor analysis and reliability results

Variable	items	mean	Std.	Factor loading	Cronbach's α	KMO
CE	CE1	3.97	0.67	0.831	0.817	0.707
	CE2	2.99	0.99	0.873		
	CE3	2.85	0.96	0.742		
AN	AN1	3.76	0.90	0.891	0.871	0.691
	AN2	3.85	0.88	0.883		
	AN3	3.37	0.89	0.702		
EL	EL1	3.56	0.87	0.781	0.823	0.723
	EL2	3.57	0.89	0.863		
	EL3	3.00	0.90	0.861		
ME	ME1	4.06	0.75	0.812	0.809	0.699
	ME2	3.09	0.91	0.622		
EF	EF1	3.95	0.75	0.851	0.802	0.802
	EF2	3.81	0.82	0.776		
	EF3	3.70	0.81	0.691		
DE	DE1	3.77	0.79	0.744	0.882	0.782
	DE2	3.45	0.85	0.821		
	DE3	3.23	0.93	0.783		
IN	IN1	3.50	0.84	0.774	0.896	0.746
	IN2	3.63	0.78	0.883		
	IN3	3.95	0.95	0.636		
	IN4	3.54	0.82	0.684		
COO	COO1	3.25	0.99	0.866	0.813	0.903
	COO2	3.22	0.96	0.854		
	COO3	3.49	0.96	0.733		
	COO4	3.00	0.98	0.807		
	COO5	3.19	0.98	0.702		
PV	PV1	3.51	0.92	0.69	0.817	0.81
	PV2	3.38	0.86	0.79		
	PV3	3.36	0.88	0.80		
PI	PI1	3.98	0.71	0.653	0.824	0.724
	PI2	3.45	0.97	0.892		
	PI3	3.19	1.03	0.682		

Confirmative Factor Analysis

In this study, AMOS software was employed to perform confirmatory factor analysis (CFA) on the variables of the model. The results are shown in Table 4. The advantage of using CFA is that you can perform a factor loading test to check statistical significance. We tested the factor structure extracted by confirmatory factor analysis to improve the overall goodness of the model's fit. The result of confirmatory factor analysis showed that $(\chi^2/df) = 2.471$. The goodness of fit of the model GFI is 0.925, and the comparative fit index 0.971, GFI and CFI are higher than 90%, indicating that our model fits very well. The value of the Tucker-Lewis coefficient (TLI) is close to 1, and greater than 0.9, indicating that the fit is good. Besides, the approximate root means square error (RMSEA) of this model is 0.04, which is less than 0.05, indicating that the model fits well. All indicators show that the model fits well.

Table 4: Goodness of fit test results of CFA

GOF index	Acceptable value	CFA model
χ^2/df	<3	2.471
P	P<0.01	0.000
CFI	>0.9	0.971
TLI	>0.9	0.955
GFI	>0.9	0.925
AGFI	>0.9	0.912
SRMR	≤0.05	0.048
RMSEA	≤0.05	0.031

Composite reliability is a measure of internal consistency in scale items. Convergent validity refers to the convergence of items

of a certain variable or a high proportion of common variation. Convergent validity can be tested by observing the loading of the measurement items in the CFA test results. CR is an index that measures reliability and internal consistency based on the factor loading square of a variable. AVE is a measure of the convergence of the variable. This value should be greater than 0.7 and at least higher than 0.5. In addition to CR and AVE, there are tools that can be used to test reliability and validity. Such as MSV, Max R, and Max r of the model. Discriminant validity can be tested by the ratio of AVE and MSV. When this value is greater than 1, it indicates that the discriminant validity test has been passed. The results are shown in Table 5. The results show that implying that all four variables indicate strong composite reliability, convergent validity, and discriminant validity.

Table 5: Composite reliability, convergent validity, and discriminant validity tests

Variable	CR	AVE	MSV	AVE/MSV
Cognitive effort	0.845	0.697	0.315	2.213
Analysis	0.803	0.628	0.308	2.039
Elaboration	0.839	0.613	0.374	1.639
Memory	0.743	0.683	0.342	1.997
Efficiency	0.761	0.547	0.259	2.112
Design	0.843	0.691	0.394	1.754
Information	0.775	0.525	0.214	2.453
COO	0.895	0.689	0.304	2.266
Perceived value	0.712	0.536	0.218	2.459
Purchase intention	0.785	0.574	0.278	2.065

Note: CR > 0.7; AVE > 0.5; MSV < AVE.

Assessment of the Structural Model

The results of the structural equation model goodness of fit test results are shown in Table 6. In this study, AMOS software was used to estimate the structural equation model. The structural equation model goodness of fit test results showed that (χ^2/df) = 2.545. The goodness of fit of the model GFI is 0.912, and the CFI (comparison fit index) is 0.956. Both GFI and CFI are higher than 90%, indicating that our model fits very well. The Tucker-Lewis coefficient (TLI) is 0.941, and the value is close to 1, which is greater than 0.9, indicating that the fit is good. Also, the approximate root means square error (RMSEA) of this model is 0.033, which is less than 0.05, indicating that the model fits well. All indicators showed that the estimated results of the structural equation model meet the minimum requirements for acceptable values, indicating that the conceptual model in this study is consistent with the empirical data and the model fits well.

Table 6: Goodness of fit test results of SEM

GOF index	Acceptable value	SEM model
χ^2/df	<3	2.545
P	P<0.01	0.000
CFI	>0.9	0.956
TLI	>0.9	0.941
GFI	>0.9	0.912
AGFI	>0.9	0.908
SRMR	≤0.05	0.046
RMSEA	≤0.05	0.033

Results of the structural model estimations are shown in the Table 7 as follows. This model takes four factors of perceived value as independent variables and uses consumers' cross-border online purchase intention as the dependent variable to perform empirical analysis to test the impact of consumer resources, cross-border e-commerce platform services and COO on purchase intention through the perceived value. Through regression analysis, it is found that the value of the adjusted R-square is acceptable according to statistical standards, the Significant value of consumer resources is 0.003, the Significant value of cross-border e-commerce platform services is 0.004, the Significant value of COO is 0.002, and the Significant value of perceived value is 0.000. All of which are less than 0.01.

This conclusion further verified that customers' cross-border online purchase willingness will be affected by customers' expertise, platform service quality, and COO through perceivable value. From the regression coefficient, the three variables have indirect positive effects on customers' cross-border online shopping willingness. The coefficient of platform service quality is 0.322, the largest one among three variables, indicating that there is an increase on the consumer's willingness to purchase across borders when the platform delivers a higher level of service quality. The coefficient of COO is 0.322, indicating that there is the stronger the consumer's willingness to purchase across borders and perceived value when the effect of COO is stronger. Therefore, it is assumed that H1, H2, H3, and H4 are verified.

Table 7: Results of the structural model estimations

Hypothesis	Description/Path	Estimate B	P value	Results
H1	Consumer Expertise→PV	0.234	0.003	Supported
H2	Platform Service Quality→PV	0.322	0.004	Supported
H3	COO→PV	0.293	0.002	Supported
H4	PV→PI	0.893	0.000	Supported

Mediation Effect Test

The mediation effect mainly explores the indirect relationship between variables, that is, the dependent variable can be influenced by independent variables through one or more intermediate variables. For the theoretical model of this research, we can easily find that consumers' perceived value is a mediating variable between consumer's expertise, platform service quality, COO, and consumer's cross-border online shopping intention.

Therefore, we use the regression method as shown in Table 8 to test the mediation effect. Regression analysis is performed on the independent variable and the mediate variable simultaneously with the dependent variable. It is found that there is fully mediation effect between perceived resources, consumer resources, platform service quality, COO, and consumers' willingness to purchase online across borders. Table 15 shows the full mediating effect of perceived value between consumer expertise and willingness to buy.

Table 8: Fully mediating effect of perceived value between consumer expertise and purchase intention

	Dependent variable	Independent variables	Sig.
Model 1	Purchase intention	(Const)	0.000
		Consumer expertise	0.000
Model 2	Purchase intention	(Const)	0.0969
		Consumer expertise	0.9120
		Perceived Value	0.000

CONCLUSIONS AND IMPLICATIONS

Conclusions

The main purpose of this paper is to explore the influencing factors of consumers' willingness to purchase in the cross-border e-commerce websites and apps. We believe that the most significant factor affecting consumers' cross-border online shopping is online service quality. And the country of origin effect also plays an important role in the cross-border purchase intention. Therefore, this study built a proposed model of cross-border online purchase intention. For the case of online cross-border shopping, perceived value is very important which can directly determine the purchase intention of customers. Based on the related theory, there are three significant latent variables that can indirectly determine the purchase intention of customers as follows: consumer resource, platform service quality (or ESQ), and country of origin. According to our positive study, platform service quality is the most important factor, and COO is the second one. All of the antecedent variables are significant according to statistical results. Empirical test results are consistent with theoretical assumptions.

Firstly, the above empirical results show that platform service quality of the cross-border online websites and apps will significantly affect consumers' perceived value and their willingness to purchase, and both of which are significant at a high level. At the same time, consumers' perceived value has a fully mediating effect on the relationship between online service quality and cross-border online purchase intention. The validity of this conclusion has also been proved by some other scholars. Nowadays, cross-border online shopping is very hot, and a lot of related cross-border e-commerce platforms and small and medium-sized cross-border e-commerce companies are emerging one after another. After all, the development of a cross-border online shipping eco-system is too fast to be a mature one. Some cross-border e-commerce platforms and companies lack experience and prospects. Therefore, some customers are not satisfied with some cross-border e-commerce platforms and companies. Some customers maybe give up the shopping on the cross-border e-commerce websites and apps for the sake of low-quality level.

But for young or high-income groups, cross-border online shopping is easy to be accepted because of buying global and high-quality goods. In addition, the group who are pursuing new things feel that cross-border online shopping is a very fashionable shopping method. This group of the population will also perceive the value of cross-border online shopping. According to the above analysis, we found that different people have different perceptions of the value of cross-border e-commerce, which indirectly affects the online shopping intentions of different consumers.

Secondly, the effect of country of origin is crucial to the purchase willingness of cross-border e-commerce users. Through the

above data analysis, it can also be found that country of origin has a positive impact on consumers' perceived value and cross-border online purchase intention, and both of which are at a significantly high level. Then consumers' perceived value has a fully mediating effect on the relationship between country of origin and purchase intention.

For cross-border e-commerce websites and apps, the transaction process is more complicated than traditional domestic online shopping. Consumers need to provide more detailed information, such as payment information and logistics clearance information. Due to the international logistics and customs clearance, consumers need to verify the accuracy of the information, which puts a great challenge on the perceived value of the websites and apps' service. Then variable international tax rules also make the cross-border online shopping process more complicated than that of traditional one. The developed country can give consumers more sense of security, a high level of logistics and service quality, etc. So how to improve the country image is very important for the developing country which wants to export more from cross-border e-commerce platforms.

Finally, consumer expertise is also a very important impact factor to the purchase willingness of cross-border e-commerce customers. We also found that the consumer expertise has a positive impact on consumers' perceived value and online purchase intention, and both of which are at a significantly high level. Then consumers' perceived value has a fully mediating effect on the relationship between consumer expertise and purchase intention.

Compared with domestic online shopping, cross-border online shopping needs more expertise and experience as follows: the knowledge of authenticity and quality of goods sold on cross-border e-commerce platforms, the knowledge of logistics security issues (Customs maybe seize the goods in case of not fully clearance information, etc.), the knowledge of payment security and qualification verifying of cross-border e-commerce. Therefore, expertise and experience are important factors affecting consumers' cross-border perceived value and purchase intention.

Implications

According to the research conclusions obtained in the paper, based on the characteristics of domestic cross-border e-commerce platforms and companies, the implications are as follows.

Firstly, we found that it can improve online service quality by expanding the range of products and promoting the customer service level offered by cross-border e-commerce platforms and companies. The mainstream cross-border e-commerce platforms in China basically only provide hot-selling products such as maternal and child, cosmetics, and clothing as well. The single-selling products mainly based on "explosive product" are often sold in hot-selling categories, so that consumers are difficult to feel the value of cross-border e-commerce for a wider range of other products. And online cross-border platforms and companies need to pay attention to the following issues: the websites and apps design, order processing efficiency, better products featured, and customer service quality.

Secondly, we found that it can improve online service quality and country image by simplifying the cross-border shopping process on related websites and apps. Because cross-border online shopping will inevitably increase the complexity of shopping process due to the difficulties of product listing, the comprehensiveness of customs clearance, and the restrictions on payment terms. Therefore, it is necessary to simplify the cross-border online shopping process.

Thirdly, it can improve the country's image by increasing qualification displaying of the cross-border online shopping websites and apps. Consumers' perceived security will have an impact on their cross-border online shopping intentions. So cross-border online platforms and companies can cooperate with the famous brand and official brand to reduce the perceived risk of cross-border e-commerce consumers.

Finally, it is crucial to help customers to form the expertise of cross-border e-commerce brands which is focused on word-of-mouth promotion. Purchase intention is significantly affected by consumers' online, and online trust is also influenced by branding and word of mouth. As a cross-border e-commerce platform or company, it should increase its brand recognition level through different communication channels. On the other hand, for the reviews function inside the websites or apps, they should strengthen the customer service capabilities, responding promptly to problems generated by consumers, and giving consumers a positive brand impression through online reviews, etc.

ACKNOWLEDGMENT

This research was supported by China Agriculture Research System (CARS-50), Huazhong Agricultural University Shishan Thinktank Project (2020SSZK07).

REFERENCES

- [1] Alba, J. W. & Hutchinson, J. W. (1987). Dimensions of consumer expertise. *Journal of Consumer Research*, 13(4), 411–454.
- [2] Frik, A. & Mittone, L. (2019). Factors influencing the perception of website privacy trustworthiness and users' purchasing intentions: The behavioral economics perspective. *Journal of Theoretical and Applied Electronic Commerce*

- Research*, 14(3):89-125.
- [3] Bhamjee, Z. (2019). Global branding and country of origin: Creativity and passion. *Asia Pacific Business Review*, 25(1):154-156.
- [4] Collier, J.E. & Bienstock, C.C. (2006). Measuring service quality in e-retailing. *Journal of Service Research*, 8(1), 260-275.
- [5] Loureiro, S. M. C. & Kaufmann, H. R. (2017). Advertising and country-of-origin images as sources of brand equity and the moderating role of brand typicality. *Baltic Journal of Management*, 12(2), 153-170.
- [6] Davies, B. & Harré, R. (1990). Positioning. *Journal for the Theory of Social Behaviour*, 20(1), 43–63.
- [7] Gomez-Herrera, E., Martens, B. & Turlea, G. (2014). The drivers and impediments for cross-border e-commerce in the EU. *Information Economics and Policy*, 28(1), 83-96.
- [8] Fassnacht, M. & Koese, I. (2006). Quality of electronic services: Conceptualizing and testing a hierarchical model. *Journal of Service Research*, 9(1), 19-37.
- [9] Grönroos, C. & Gummerus, J. (2014). The service revolution and its marketing implications: Service logic versus service–dominant logic. *Managing Service Quality*, 24(3), 206-229.
- [10] Gupta, R. & Kabadayi, S. (2010). The relationship between trusting beliefs and web site loyalty: The moderating role of consumer motives and flow. *Psychology and Marketing*, 27(2), 166–85.
- [11] Hilton, J. L., & Von Hippel, W. (1996). Stereotypes. *Annual Review of Psychology*, 47(1), 237-271.
- [12] Barrutia, J. M., Paredes, M.R. & Echebarria, C. (2016). Value co-creation in e-commerce contexts: Does product type matter? *European Journal of Marketing*, 50(3-4), 442-463.
- [13] Grewal, L. & Stephen, A. T. (2019). In mobile we trust: the effects of mobile versus nonmobile reviews on consumer purchase intentions. *Journal of Marketing Research*, 56(5), 791-808.
- [14] Peng, L., Zhang, W. & Wang X. *et al.* (2019). Moderating effects of time pressure on the relationship between perceived value and purchase intention in social e-commerce sales promotion: Considering the impact of product involvement. *Information & Management*, 56(2), 317-328.
- [15] Theodosiou, M., Katsikea, E., Samiee, S., & Makri, K. (2019). A comparison of formative versus reflective approaches for the measurement of electronic service quality. *Journal of Interactive Marketing*, 47, 53-67.
- [16] Mpinganjira, M., & Maduku, D. K. (2019). Ethics of mobile behavioral advertising: Antecedents and outcomes of perceived ethical value of advertised brands. *Journal of Business Research*, 95, 464-478.
- [17] Qin, Z., Zhao L.W. & Ni, Y. (2019). The Influencing Factors on Consumers' Purchase Intention under the Cross-border E-commerce Platforms . In *Proceedings of The 19th International Conference on Electronic Business* (pp. 1-13). ICEB, Newcastle upon Tyne, UK, December 8-12.
- [18] Ng, S. C., Sweeney, J. C., & Plewa, C. (2019). Managing customer resource endowments and deficiencies for value cocreation: complex relational services. *Journal of Service Research*, 22(2), 156-172.
- [19] Suh, Y., Hur, J., & Davies, G. (2016). Cultural appropriation and the country of origin effect. *Journal of Business Research*, 69(8), 2721-2730.
- [20] Underwood, R. L., Klein, N. M., & Burke, R. B. (2001). Packaging communication: Attentional effects of product imagery. *The Journal of Product and Brand Management*, 10(7), 403-422.
- [21] Vargo, S. L., & Lusch, R. F. (2008). Service-dominant logic: continuing the evolution. *Journal of the Academy of Marketing Science*, 36(1), 1-10.
- [22] Zeithaml, V. A., Parasuraman, A., & Malhotra, A. (2002). Service quality delivery through web sites: a critical review of extant knowledge. *Journal of the Academy of Marketing Science*, 30(4), 362-375.

Dynamic Perturbation Grasshopper Optimization Algorithm for Engineering Design Problems

(Full Paper)

Yu Li, Henan University, China, leey@henu.edu.cn

Xuechen Tu, Henan University, China, 104753180946@vip.henu.edu.cn

Jingsen Liu*, Henan University, China, ljs@henu.edu.cn

ABSTRACT

This paper presents a dynamic perturbation grasshopper optimization algorithm for engineering design problems. Three effective strategies were proposed to avoid the drawbacks of the original GOA that falling into local optimum easily and had a slow convergence speed. First, a dynamic attenuation adjustment factor was introduced to balance the exploration and exploitation in the search space and accelerated the convergence speed. Then, Cauchy inverse cumulative distribution function was employed for modifying the grasshopper's position to increase the randomness of each grasshopper's movement and improved the algorithm on the global optimization ability. Finally, Gaussian mutation will take smaller steps allowing for every corner of the search space to be explored in a much better way. To testify the effectiveness of the proposed strategies to the algorithm improvement, the proposed DPGOA was tested by 17 benchmark functions and the statistical tests contain Friedman test and Wilcoxon rank-sum test. As the experimental results showed, the proposed DPGOA was significantly superior to other natural-inspired algorithms both in convergence speed and accuracy. Finally, the competitive results of two real-world engineering problems illustrates the proposed DPGOA can be deployed to constrained optimization problems or other fields for future work.

Keywords: Grasshopper optimization algorithm, dynamic attenuation adjustment factor, Cauchy inverse cumulative distribution, Gaussian mutation, engineering design problems.

*Corresponding author

INTRODUCTION

The concept of swarm intelligence comes from the observation of the population of social organisms in nature. The macro intelligent behavior characteristics of the population through cooperation are called swarm intelligence. Swarm intelligent optimization algorithm (Brownlee, 2011) mainly simulates the group behavior of insects, herds, birds and fish, etc., which search for food in a cooperative way. Swarm intelligent Optimization algorithm has always attracted the attention of scholars. Since Ant Colony Optimization (ACO) (Dorigo *et al.*, 1996) was proposed by Dorigo, swarm intelligent algorithm has been formally proposed as a theory. Subsequently, a number of intelligent Optimization algorithms have been proposed and widely applied in various fields, such as Particle Swarm Optimization Algorithm (PSO) (Eberhart & Kennedy, 1995; Lyu *et al.*, 2020), Simulated Annealing Algorithm (SA) (Kirkpatrick *et al.*, 1983), Cuckoo Search Algorithm (CS) (Yang & Deb, 2009), Bat Algorithm (BA) (Yang, 2010), Artificial Bee Colony Algorithm (ABC) (Karaboga & Basturk, 2007), Firefly Algorithm (FA) (Yang, 2009; Liu *et al.*, 2020), Flower Pollination Algorithm (FPA) (Liu *et al.*, 2019) and Harmony Search Algorithm (HS) (Jeong *et al.*, 2020). In recent years, a variety of new swarm intelligence optimization algorithms have emerged, such as Whale Optimization Algorithm (WOA) (Mirjalili & Lewis, 2016; Li *et al.*, 2019), Grey Wolf Optimization Algorithm (GWO) (Mirjalili, 2014), Emperor Penguin Optimization Algorithm (EPO) (Dhiman & Kumar, 2018), Ant-lion Optimization Algorithm (ALO) (Dorigo *et al.*, 2006), Moth-flame Optimization Algorithm (MFO) (Mirjalili, 2015), which have been proposed and applied to optimization problems.

In 2017, a new nature-inspired swarm intelligence optimization algorithm called Grasshopper Optimization Algorithm (GOA) (Saremi *et al.*, 2017) was proposed, which simulates the swarm behavior of grasshoppers in nature to solve the optimization problems. Many scholars have improved the shortcomings of GOA. Mirjalili *et al.* (2018) proposed a multi-objective GOA to make GOA optimize the multi-objective optimization problem, and the results showed that the proposed algorithm could obtain very competitive results in terms of the pareto optimal solution and its distribution accuracy. Tharwat *et al.* (2018) also proposed an improved multi-objective GOA (MOGOA), and the results showed that the effect of MOGOA was better than that of other peer algorithms for optimizing multi-objective problems. Ewees *et al.* (2018) introduced the OBL strategy in GOA, and 50% solutions of OBL strategy was remained in the exploration phase of GOA, and the results obtained excellent results in engineering optimization problems. To accelerate the global convergence speed of GOA, Arora and Anand (2019) introduced 10 chaotic maps into the optimization process of GOA, proving that chaotic maps, especially circle maps, can significantly improve the performance of GOA. Mafarja *et al.* (2018) introduced an improvement strategy called Evolutionary Population Dynamics (EPD), and the experimental results showed that EPD had a significant impact on the optimization performance of GOA.

GOA is also widely used in adjusting parameters of optimization problems: Montano *et al.* (2020) proposed that Grasshopper Optimization Algorithm (GOA) was accurately applied to estimate the optimal parameters of the single diode model (SDM) of photovoltaic modules from the experimental data, which verified the good relation between the computational time and the reliability of GOA's parameter estimation of photovoltaic modules. Barman *et al.* (2018) used GOA to evaluate the parameters of the hybrid STLF model and proposed a GOA-SVM model for short-term load prediction under local climatic conditions. Based on the seven unknown parameters of proton exchange membrane fuel cell (PEMFCs), El-Fergany (2017) uses GOA to optimize the unknown parameters and establish an appropriate model. Experimental results show the effectiveness of the proposed method. Jumani *et al.* (2018) develops an optimal control strategy for the voltage and frequency regulation of Photovoltaic (PV) based MG systems operating in islanding mode, which using Grasshopper Optimization Algorithm (GOA) to optimize the PI controller parameters, and the simulation results shows that the GOA can obtain a better solution.

Due to the slow convergence speed of GOA algorithm and easy to fall into local optimal, the effect of applying GOA directly to practical engineering problems is not very significant. Therefore, scholars proposed some improvement strategies for GOA to improve its performance in practical engineering problems. Several scholars have modified GOA to a binary version and applied it to optimization problems. Pinto *et al.* (2018) and Crawford *et al.* (2018) use a general binarization mechanism based on the percentile concept and apply it to the multi-dimensional knapsack problem (MKP) and set covering problem (SCP). In Mafarja's work (2019), binary variants of the GOA was proposed and employed to select the optimal feature subset for classification purposes within a wrapper-based framework, the results are superior compared to other similar techniques. In other practical engineering problems, Lukasik *et al.* (2017) applied GOA to data clustering, and the experimental results show that this method can achieve higher accuracy compared with the standard k-means method. Wu *et al.* (2017) applied adaptive GOA (AGOA) to the trajectory optimization of cooperative target tracking of solar UAVs in urban environment. Tumuluru and Ravi (2017) applied GOA to update depth believe the weights of neural network and applied to the cancer classification problem; In addition, GOA is also applied in vibration fault identification (Zhang *et al.*, 2018), partial shadow photovoltaic array optimization and reconstruction (Fathy, 2018), parameter optimization (Heidari *et al.*, 2018), PID controller parameter optimization (Guha *et al.* 2019), optimal load frequency control (Nosratabadi *et al.*, 2019), data clustering (Lukasik *et al.*, 2017) and other fields.

This study described an improved GOA called DPGOA to solve the disadvantages of slow convergence speed and easy to fall into local optimal, three improved strategies were applied to the algorithm. The first strategy is to change the parameter c of GOA as a dynamic attenuation adjustment factor to balance the optimization capability of the algorithm in the exploration and exploitation stage. The second strategy is to introduce the Cauchy inverse cumulative distribution function to increase the diversity of the population. The third strategy is to use the Gaussian function to perturb the target position to help the algorithm jump out of the local optimal. To demonstrate the performance of the proposed approach, the DPGOA is tested by seventeen standard mathematical functions and two statistical test methods contains Friedman test and Wilcoxon rank-sum test, which make progress among other state-of-art intelligent algorithms. Furthermore, the DPGOA for solving two engineering structural optimization problems shows the proposed methods can receive competitive results than the comparison optimization approaches.

For the rest of this paper, Section 2 introduces GOA algorithm composed of its biological principle and search mechanism, Section 3 describes the three enhanced methods proposed in this paper to improve GOA algorithm, including dynamic adjustment factor, inverse cumulative distribution function of Cauchy distribution and Gaussian mutation. Section 4 presents the simulation experiment results of benchmark functions and statistical test results. Section 5 applies DPGOA to two real-world engineering design problems. Finally, the conclusion of this paper and worthwhile work direction for further research are given in Section 6.

GRASSHOPPER OPTIMIZATION ALGORITHM (GOA)

GOA optimization algorithm was first proposed by Saremi (2017), which was inspired by the breeding, gathering, foraging and migration behaviors of grasshoppers in nature. This group behavior of grasshoppers corresponds to the exploration and exploitation of GOA. In the exploration phase of the algorithm, the search individual makes a sudden movement; in the exploitation phase of the algorithm, the search agent is more of a small range of movement. According to the mathematical model proposed by the GOA, the location of grasshoppers is mainly affected by three factors: social interaction, gravity and wind advection. The mathematical formula is as follows:

$$X_i = S_i + G_i + A_i \quad (1)$$

Where X_i is the position of the i th grasshopper, S_i is the social interaction, G_i is the gravity force and A_i is the wind advection. S_i is the key parameter to determine the location of grasshoppers, which is calculated by the following formula:

$$S_i = \sum_{\substack{j=1 \\ j \neq i}}^N s(d_{ij}) \frac{(x_j - x_i)}{d_{ij}} \quad (2)$$

$$d_{ij} = |x_j - x_i| \quad (3)$$

Where d_{ij} represents the distance between the i th and the j th grasshopper, s defines the social forces that is determined by the parameters f and l , which can be calculated by the following formula:

$$s(r) = f e^{-\frac{r}{l}} - e^{-r} \quad (4)$$

Where f is the intensity of attraction, l is the attractive length scale. It should be noted that, according to the original algorithm, if the distance between the grasshoppers is too long, social forces will not be able to provide a strong force on the grasshoppers. Therefore, GOA maps the distance between grasshoppers to an interval [1, 4]. The function s illustrated in Fig. 1 shows the influence of social forces on grasshoppers.

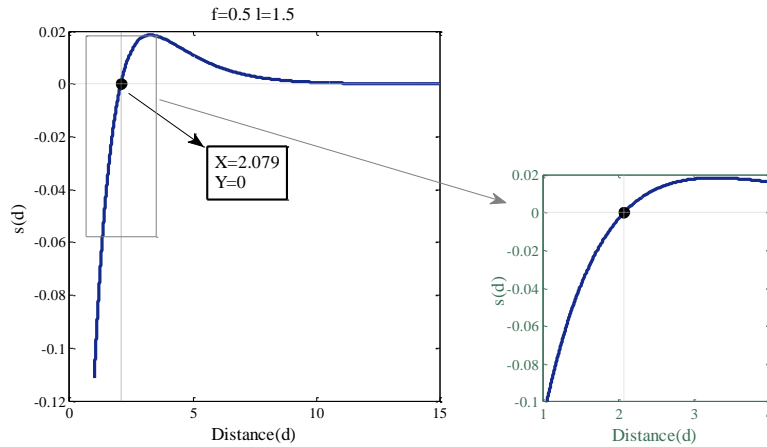

Source: This study.

Figure 1: (left) Function s when $f = 0.5$ and $l = 1.5$ (right) range of function s when x is in [1, 4].

The gravity force and wind advection of the grasshopper can be calculated by the following equations:

$$G_i = -g \hat{e}_g \quad (5)$$

$$A_i = u \hat{e}_w \quad (6)$$

Where g is the gravitational constant and \hat{e}_g is a unity vector towards the center of earth, u is a constant drift and \hat{e}_w is a unity vector in the direction of wind. It should be noted that this mathematical model cannot be directly used for optimization problems. Therefore, substituting Eq. (2) ~ Eq. (6) into Eq. (1), the mathematical model modified by the original author is as follows:

$$X_i^d = c \left(\sum_{j=1}^N c \frac{ub-lb}{2} s(|x_j - x_i|) \frac{x_j - x_i}{d_{ij}} \right) + \hat{T}_d \quad (7)$$

Where ub and lb indicate the upper and lower bound of the search space, \hat{T}_d is the value of the d th dimension which is the best solution found so far, c is a decreasing coefficient, which can be shown in Eq.(8).

$$c = cmax - t \frac{(cmax - cmin)}{t_{max}} \quad (8)$$

Where $cmax$ is the maximum value, $cmax = 1$, $cmin$ is the minimum value, $cmin = 0.00001$, t represents the current iteration, and t_{max} represents the maximum number of iterations.

DYNAMIC PERTURBATION GRASSHOPPER OPTIMIZATION ALGORITHM (DPGOA)

In subsections, this paper shows three aspects of improvement: First, a dynamic attenuation factor is introduced to improve grasshopper's local optimization ability; then, grasshopper position information of global search is mutated by Cauchy distribution accumulation function method to improve grasshopper's global search capability; finally, Gaussian mutation is used to create a new offspring near the target position.

Dynamic Attenuation Adjustment Factor (DA)

In the position update phase of the algorithm, parameter c is an important decreasing parameter that GOA affects the search agents in the search space. The parameter c in Eq. (7) is applied twice. The parameter c outside the parenthesis is similar to the inertia weight (w) in PSO, which can be seen from Eq. (8) that it is linearly decreasing. The parameter c in parenthesis helps reduce the attraction and repulsion between grasshoppers. If the parameter c drops too fast, the convergence in the early stage of GOA algorithm will be insufficient. Otherwise, the local search in the later stage of the algorithm will be unable to search accurately. Therefore, an improved strategy of dynamic attenuation adjustment factor is proposed to enhance the global searching ability in the early stage, and local searching ability in the later stage. The improved dynamic attenuation adjustment factor c is as follows:

$$c = cmin + (cmax - cmin) \times e^{-\frac{t^2}{(k \times t_{max})^2}} \quad (9)$$

In Eq. (9), $c_{max} = 1$, $c_{min} = 0.00001$, $k = 0.1$, and k is the curvature adjustment factor, which used to adjust the rate of change of the curve.

Inverse Cumulative Distribution Function of Cauchy Distribution (CD)

In this paper, Cauchy mutation operator was introduced to enhance the GOA algorithm. The Cauchy distribution has a smaller peak at the origin and two longer peaks at both ends, so the Cauchy mutation can make full use of the existing information of individual search agent, producing larger disturbance near the search agent. So this paper uses Cauchy inverse cumulative distribution function, which is as follows:

$$F^{-1}(p; x_0, \gamma) = x_0 + \gamma \cdot \tan\left(\pi \cdot \left(p - \frac{1}{2}\right)\right) \quad (10)$$

In Eq. (10), F^{-1} is the inverse cumulative distribution function of Cauchy distribution. x_0 is the position parameter defining the distribution peak position; γ is the scale parameter of half width at half of maximum value. In this paper, $x_0=0, \gamma=1$, F^{-1} is the standard Cauchy distribution. The "long-tail" characteristic of Cauchy distribution (Guo *et al.*, 2017) was used to enlarge the search range of grasshopper agents, which enhance the diversity of the population, making the algorithm easier to jump out of local optimal. Therefore, the inverse cumulative distribution function was selected in this paper to update the location of the grasshopper agents, which not only promote the global optimization ability, but also accelerates the convergence speed.

Gaussian Mutation (GM)

The Gaussian mutation strategy in this paper is derived from the Gaussian distribution, which is also known as normal distribution. It has a very wide practical background in mathematics, physics, engineering and other fields. The probability distribution of many random variables in production and scientific experiments can be approximately described by the normal distribution.

The curve of Gaussian distribution is high in the middle and narrow at both ends, so it has significant search ability in a small range, and it is easier to produce new offspring with less variation near the target location with a large probability. When applied to the update phase of the algorithm, the Gaussian mutation is to replace the original grasshopper position by adding a random disturbance following the Gaussian distribution. The Gaussian density function is given by:

$$f_{\text{gaussian}(\mu, \sigma^2)}(\alpha) = \frac{1}{\sqrt{2\pi\sigma^2}} e^{-\frac{\alpha-\mu}{2\sigma^2}} \quad (11)$$

Where μ refers to the mean value of Gaussian distribution, σ^2 is the variance of the Gaussian distribution, $\sigma^2 = 1$. A random number is obtained through the Gaussian distribution function, which is used to conduct a small range of perturbations at the target position. Fig. 1 shows the comparison between different values of the parameters μ and σ of Gaussian distribution. In this paper, $\mu = 0, \sigma = 1$.

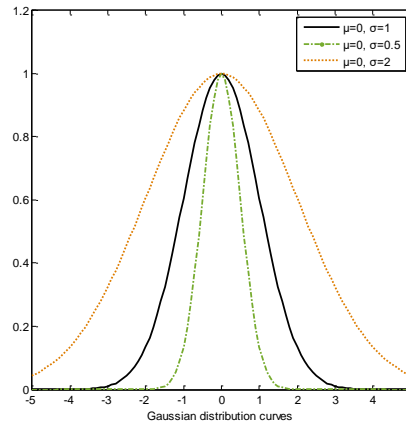

Source: This study.

Figure 2: Comparison of different values of parameters μ and σ .

The modified mathematical model improved by three strategies can be presented as follows:

$$X_i^d = c \oplus F^{-1}\left(\sum_{j=1}^N c \frac{ub-lb}{2} s(|x_j - x_i|) \frac{x_j - x_i}{d_{ij}}\right) + \widehat{T}_d \oplus G(\alpha) \quad (12)$$

The pseudo code of the DPGOA is shown in Algorithm 1:

Algorithm 1 Pseudo code of Dynamic perturbation Grasshopper Optimization Algorithm

- 1: Initialize the parameters: population size N , c_{max} , c_{min} and maximum iterations L ;
 - 2: Generate the initial swarm $X_i(i = 1, 2, \dots, n)$;
-

```

3: Calculate the fitness of each agent;
4: Set  $T$  as the best solution of all agents;
5: while  $l < L$  do
6:   Update  $c$  using Eq.(9);
7:   for  $i = 1:N$  do
8:     Normalize the distance between grasshopper in the interval [1,4];
9:     Update the position of the current agent using Eq.(12);
10:    Bring the current agent back if it goes outside the boundaries;
11:    Update  $T$  if there is a better solution;
12:  end for
13:   $l = l + 1$ ;
14: end while
15: Return  $T$ ;

```

EXPERIMENTS AND RESULTS

In this section, to test the performance of the proposed DPGOA, a series of experiments are evaluated on DPGOA on benchmark functions. To obtain statistically significant results, all experiments were conducted under the same conditions as follows: all experiments in this paper were performed using MATLAB 2014a software under a Windows 7 (64bit) operating system with Intel(R) Core (TM) i5-4210U CPU @ 1.70 GHz and 4 GB of running memory.; To maintain the principle of consistency, the population size $N = 30$, and the maximum iterations $t_{max} = 500$. Each approach was run independently for 30 times to ensure the fairness of the experiment.

Standard Benchmark Function

In this section, the performance of the proposed DPGOA will be tested using 17 benchmark functions including unimodal functions f_{1-11} , and multimodal functions f_{12-17} . Table 1 shows a brief description of the 17 benchmark functions and their theoretical optimal values.

Table 1: Benchmark functions.

Name	Function	Range	f_{min}
Sphere	$f_1(x) = \sum_{i=1}^n x_i^2$	[-100,100]	0
Schwefel 2.22	$f_2(x) = \sum_{i=1}^n x_i + \prod_{i=1}^n x_i $	[-10,10]	0
Schwefel 1.2	$f_3(x) = \sum_{i=1}^i (\sum_{j=1}^i x_j)^2$	[-100,100]	0
Schwefel 2.21	$f_4(x) = \max_i \{ x_i , 1 \leq i \leq n\}$	[-100,100]	0
Rotated hypr-ellipsoid	$f_5(x) = \sum_{i=1}^p (\sum_{j=1}^i x_j)^2$	[-100,100]	0
Sum-Square	$f_6(x) = \sum_{i=1}^p i x_i^2$	[-10,10]	0
Sum-Power	$f_7(x) = \sum_{i=1}^p x_i ^{i+1}$	[-1,1]	0
Noise	$f_8(x) = \sum_{i=1}^p i x_i^4$	[-1.28,1.28]	0
Cigar	$f_9(x) = x_1^2 + 10^6 \sum_{i=2}^p x_i^6$	[-100,100]	0
Tablet	$f_{10}(x) = 10^6 \cdot x_1^2 + \sum_{i=2}^p x_i^6$	[-1,1]	0
Step 2	$f_{11}(x) = \sum_{i=1}^p [x_i + 0.5]^2$	[-100,100]	0
Rastrigin	$f_{12}(x) = \sum_{i=1}^n [x_i^2 - 10 \cos(2\pi x_i) + 10]$	[-5.12,5.12]	0
Ackley	$f_{13}(x) = -20 \exp \left(-0.2 \sqrt{\frac{1}{n} \sum_{i=1}^n x_i^2} \right) - \exp \left(\frac{1}{n} \sum_{i=1}^n \cos(2\pi x_i) \right) + 20 + e$	[-32,32]	0
Griewank	$f_{14}(x) = \frac{1}{4000} \sum_{i=1}^n x_i^2 - \prod_{i=1}^n \cos \left(\frac{x_i}{\sqrt{i}} \right) + 1$	[-600,600]	0
Elliptic	$f_{15}(x) = \sum_{i=1}^p (10^6)^{\frac{i-1}{p-1}} x_i^2$	[-100,100]	0
Inverted Cosine Mixture	$f_{16}(x) = 0.1D - (0.1 \sum_{i=1}^p \cos(5\pi x_i) - \sum_{i=1}^p x_i^2)$	[-1,1]	0
Alpine	$f_{17}(x) = \sum_{i=1}^p x_i \cdot \sin(x_i) + 0.1x_i $	[-10,10]	0

Performance Measures

Three performance measures were selected to evaluate the performance of the proposed algorithm. The first performance indicator is the best value of the algorithm. The smaller the best solution is obtained by the proposed algorithm, the better the performance of the algorithm will be. The second performance indicator is the average value of the algorithm after different independent runs. The

third performance indicator is the standard deviation of the optimal solution of the algorithm. The function of standard deviation is to detect the dispersion degree of a data set. If the data dispersion degree is large, the algorithm is unstable; otherwise, the algorithm is stable.

The Influence of DA, CD and GM

In Section 3, three search strategies are proposed, namely dynamic attenuation adjustment factor (DA), Cauchy variation (CD) and Gaussian mutation (GM). To verify the influence of each strategy and the random combination of three strategies on the optimization performance of the GOA, three search strategies (DA, CD and GM) are combined with the basic GOA to generate seven combination schemes, which are respectively denoted as DPGOA1-7. For DPGOA1, it means that GOA only combines DA strategy. For DPGOA2, it means that GOA is only combined with CD strategy; For DPGOA3, it means that GOA is only combined with GM strategy; For DPGOA4, it means the combination of GOA with DA and CD strategies. For DPGOA5, it is a combination of GOA with CD and GM strategies. For DPGOA6, it is a combination of GOA with DA and GM strategies. The last DPGOA7 applies three strategies to GOA at the same time. Table 2 shows the results of DPGOA1-7 for the 17 benchmark functions when D=10; Table 3 shows the results when D=30, and table 4 shows the results when D=50.

Table 2: Comparison of various DPGOAs (D=10).

F	GOA			DPGOA1			DPGOA2		
	best	ave	std	best	ave	std	best	ave	std
f_1	1.28e-09	1.65e-08	1.56e-08	3.26e-19	4.26e-19	8.12e-20	1.78e-09	1.66e-08	2.29e-08
f_2	2.92e-05	1.81	2.26	2.49e-02	1.40	1.76	3.8e-03	2.35	2.94
f_3	7.63e-09	1.56e-05	6.08e-05	7.34e-09	6.0e-03	1.0e-02	6.67e-09	3.02e-08	2.31e-08
f_4	2.5e-05	5.73e-04	1.7e-03	3.08e-10	3.89e-10	5.48e-11	2.92e-05	6.88e-05	3.47e-05
f_5	0.15	0.25	0.11	16.18	68.90	103.40	1.20e-03	1.32e-02	1.47e-02
f_6	2.11e-06	7.12e-06	7.40e-06	9.91e-07	0.71	1.01	9.03e-08	1.97e-06	2.63e-06
f_7	5.97e-07	7.64e-07	1.92e-07	1.48e-06	1.71e-05	1.41e-05	5.50e-08	1.11e-07	4.42e-08
f_8	6.23e-19	4.49e-13	7.78e-13	2.25e-16	3.44e-12	2.99e-12	3.19e-20	4.06e-19	4.54e-19
f_9	794.92	2.16e+03	2.17e+03	1.16	2.47e+03	2.99e+03	12.53	1.86e+03	2.32
f_{10}	1.28e-06	3.91e-06	3.71e-06	1.25e-05	8.09e-05	4.68e-05	5.16e-09	3.64e-08	3.10e-08
f_{11}	1.98	2.33	0.57	0	1.60	1.14	0	0.80	1.30
f_{12}	4.19e-04	1.03e+01	7.78	3.24	1.09e+01	9.92	2.64	1.33e+01	1.13e+01
f_{13}	2.35e-05	6.28e-01	9.98e-01	3.02e-02	1.05	9.19e-01	9.6e-04	2.27	2.45
f_{14}	4.93e-02	1.45e-01	5.81e-02	4.44e-02	1.49e-01	8.48e-02	1.1e-01	2.38e-01	9.83e-02
f_{15}	7.46e+05	1.86e+06	1.35e+06	7.44e+05	2.93e+06	2.63e+06	4.98e+04	6.06e+05	5.39e+05
f_{16}	0.14	0.44	0.25	0.29	0.53	0.32	0.14	0.65	0.28
f_{17}	9.28e-02	0.12	2.92e-02	0.74	2.21	1.87	2.50e-03	1.83	1.87
F	DPGOA3			DPGOA4			DPGOA5		
	best	ave	std	best	ave	std	best	ave	std
f_1	3.63e-14	1.81e-13	2.07e-13	9.22e-25	4.88e-24	3.88e-24	8.73e-16	1.19e-14	1.55e-14
f_2	2.34e-09	8.08e-08	1.1e-07	5.32e-01	3.46	3.6	5.85e-09	1.57e-08	8.96e-09
f_3	2.77e-17	6.28e-13	9.52e-13	8.8e-16	4.9e-06	8.92e-06	9.86e-16	5.63e-14	6.09e-14
f_4	3.75e-08	3.86e-07	4.42e-07	2.88e-12	8.47e-07	1.05e-06	9.59e-09	1.54e-07	1.57e-07
f_5	6.13e-15	3.06e-12	5.93e-12	4.54	114.94	137.05	6.07e-17	1.08e-13	1.28e-13
f_6	1.79e-15	2.30e-13	4.72e-13	2.79e-02	1.25	2.05	1.72e-18	1.68e-14	3.70e-14
f_7	3.81e-28	4.65e-21	9.47e-21	5.51e-07	4.64e-06	8.02e-06	2.56e-24	6.84e-23	1.33e-22
f_8	1.39e-33	2.51e-30	5.24e-30	4.70e-15	5.59e-06	7.85e-06	3.62e-43	1.32e-35	2.53e-35
f_9	1.47e-20	4.62e-16	9.55e-16	1.84e+03	4.48e+03	2.73e+03	4.60e-20	7.65e-18	1.45e-17
f_{10}	6.69e-31	9.34e-22	1.32e-21	6.95e-06	7.47e-05	7.76e-05	1.45e-28	6.67e-23	1.44e-22
f_{11}	0	0	0	1.02	3.60	2.70	0	0	0
f_{12}	2.84e-14	1.21e-12	2.09e-12	3.42	1.09e+01	7.5	0	0	0
f_{13}	4.87e-09	3.62e-07	4.43e-07	1.27e-01	1.45	1.22	3.56e-09	7.81e-08	9.36e-08
f_{14}	1.26e-13	4.96e-12	4.95e-12	8.38e-02	1.65e-01	7.58e-02	9.54e-15	4.2e-13	5.35e-13
f_{15}	1.18e-09	6.42e-09	3.77e-09	1.58e+06	2.56e+06	1.28e+06	4.44e-14	1.61e-08	3.04e-08
f_{16}	0	9.99e-16	1.99e-15	0.14	0.41	0.24	0	8.88e-17	1.44e-16
f_{17}	6.29e-09	1.11e-08	6.20e-09	0.19	1.12	0.91	3.28e-10	9.88e-09	1.36e-08

F	DPGOA6			DPGOA7		
	best	ave	std	best	ave	std
f_1	1.76e-23	5.29e-21	5.46e-21	2.16e-28	2.36e-25	2.9e-25
f_2	1.55e-12	1.05e-11	1.06e-11	7.86e-16	4.56e-14	4.22e-14
f_3	1.23e-21	3.83e-21	2.73e-21	5.8e-26	4.42e-25	6.84e-25
f_4	2.37e-11	4.88e-11	1.78e-11	5.46e-14	1.52e-13	6.65e-14
f_5	6.33e-21	7.49e-20	5.90e-20	9.91e-27	3.52e-25	4.62e-25
f_6	9.95e-22	4.20e-21	3.15e-21	2.56e-27	5.31e-26	6.96e-26
f_7	2.17e-32	7.86e-31	1.20e-30	2.28e-35	9.83e-33	1.77e-32
f_8	8.78e-50	4.54e-48	5.34e-48	1.15e-58	1.28e-56	1.65e-56
f_9	1.69e-42	4.44e-31	8.37e-31	1.42e-37	1.46e-28	3.22e-28
f_{10}	5.33e-42	8.58e-40	1.31e-39	2.54e-51	9.25e-50	2.02e-50
f_{11}	0	0	0	0	0	0
f_{12}	0	0	0	0	0	0
f_{13}	1.87e-11	5.7e-11	2.85e-11	4.44e-15	1.92e-13	1.41e-13
f_{14}	0	0	0	0	0	0
f_{15}	1.95e-17	2.87e-16	3.45e-16	4.88e-21	2.01e-20	3.05e-20
f_{16}	0	0	0	0	0	0
f_{17}	1.78e-12	4.34e-12	1.84e-12	2.5e-16	1.73e-14	1.40e-14

Table 3: Comparison of various DPGOAs (D=30).

F	GOA			DPGOA1			DPGOA2		
	Best	ave	std	best	ave	std	best	ave	std
f_1	7.76	1.9e+01	4.2e+01	2.26e-04	2.69e-02	3.39e-02	9.99e-07	1.97e-06	1.46e-06
f_2	2.87	2.4e-03	2.5e-03	1.05e-01	8.03e-01	7.3e-01	5.03e-02	2.0	2.51
f_3	1.39e-01	2.22	3.28	4.05e+01	1.19e+02	1.12e+02	1.5e-03	6.0e-03	6.2e-03
f_4	1.09e-02	1.46e-01	7.85e-02	1.64e-01	1.49	1.63	3.3e-03	2.1e-02	1.7e-02
f_5	715.21	1.94e+03	1.06e+03	9.52e+03	9.98e+03	8.63e+02	501.65	615.44	160.92
f_6	10.95	36.60	23.40	122.25	153.20	213.20	1.44	1.58	0.21
f_7	8.06e-06	1.16e-05	5.96e-06	4.82e-05	6.69e-05	3.76e-05	2.23e-07	5.19e-07	4.18e-07
f_8	1.76e-06	1.17e-05	1.01e-05	9.50e-03	8.69e-02	6.49e-02	1.94e-10	1.95e-10	1.97e-12
f_9	1.12e+08	1.44e+11	2.48e+11	1.36e+10	1.90e+11	1.10e+13	8.71e+03	1.52e+05	2.03e+05
f_{10}	1.38e-04	2.28e-04	8.70e-05	3.40e-03	6.13e-03	1.98e-03	9.04e-07	1.42e-06	7.32e-07
f_{11}	31.68	112.96	103.79	3.05e+02	2.16e+03	1.36e+03	19.03	23.59	6.36
f_{12}	1.69e+01	2.98e+01	1.26e+01	1.59e+01	2.64e+01	1.22e+01	1.09e+01	3.46e+01	1.84e+01
f_{13}	1.3e-03	5.61e-01	7.85e-01	1.99	5.65	7.63	4.37e-04	1.39	1.09
f_{14}	1.01e-01	2.25e-01	1.03e-01	7.92e-02	1.53e-01	8.52e-02	6.69e-02	1.2e-01	3.83e-02
f_{15}	8.66e+06	1.30e+07	3.98e+06	1.75e+06	2.10e+06	1.26e+07	6.55e+06	7.12e+06	8.06e+05
f_{16}	1.34	1.51	0.22	2.24	2.68	3.49	1.03	1.62	0.83
f_{17}	8.21	8.88	1.02	15.54	17.69	10.36	3.22	5.56	3.29
F	DPGOA3			DPGOA4			DPGOA5		
	best	ave	std	best	ave	std	best	ave	std
f_1	8.74e-15	6.11e-13	1.12e-12	1.77e-05	2.48e-03	3.41e-03	3.59e-15	1.5e-13	1.71e-13
f_2	4.94e-09	1.67e-07	2.42e-07	1.18	3.49	2.55	5.16e-09	3.95e-08	4.81e-08
f_3	2.38e-14	2.88e-12	5.14e-12	9.16	5.65e+01	5.72e+01	8.72e-16	4.06e-13	5.38e-13
f_4	2.02e-07	5.8e-07	3.37e-07	1.9	3.99	3.63	7.59e-09	1.23e-07	1.36e-07
f_5	9.12e-12	1.32e-11	5.80e-12	1.41e+04	1.96e+04	1.32e+04	1.27e-13	1.06e-12	1.32e-12
f_6	4.04e-15	2.55e-12	3.60e-12	184.85	235.96	72.16	4.65e-15	1.57e-13	2.16e-13
f_7	9.43e-23	2.71e-20	3.82e-20	3.88e-06	6.43e-05	8.54e-05	2.72e-21	6.67e-21	5.58e-21
f_8	1.01e-30	1.21e-30	2.93e-31	1.02e-02	0.71	0.97	3.68e-34	7.19e-32	1.01e-31
f_9	7.75e-19	9.52e-17	1.33e-16	1.57e+13	6.26e+13	6.61e+13	6.34e-19	7.45e-18	9.64e-18
f_{10}	9.50e-29	1.27e-20	1.79e-20	1.31e-03	2.69e-03	1.70e-03	4.76e-27	1.82e-25	2.51e-25
f_{11}	0	0	0	1.67e+03	2.68e+03	1.43e+03	0	0	0

f_{12}	3.26e-13	2.8e-12	3.32e-12	2.88e+01	5.17e+01	1.79e+01	0	9.66e-14	1.79e-13
f_{13}	6.32e-08	5.45e-07	7.58e-07	5.5e-03	3.68	2.84	5.39e-09	3.65e-08	2.87e-08
f_{14}	5.55e-16	1.4e-11	2.35e-11	9.73e-02	2.17e-01	1.09e-01	7.32e-15	1.41e-13	2.85e-13
f_{15}	2.66e-07	5.28e-07	3.69e-07	2.04e+07	4.70e+07	3.75e+07	3.59e-11	3.77e-10	4.83e-10
f_{16}	0	7.32e-15	1.03e-14	3.34	3.57	0.32	0	0	0
f_{17}	4.03e-08	7.34e-08	4.68e-08	11.17	14.99	5.41	1.98e-08	2.60e-08	8.71e-09
F	DPGOA6			DPGOA7					
	best	ave	std	best	ave	std			
f_1	3.61e-21	2.24e-20	1.8e-20	1.19e-26	5.91e-25	8.6e-25			
f_2	2.28e-11	3.8e-11	1.1e-11	4.78e-15	1.58e-13	1.21e-13			
f_3	2.13e-20	7.15e-20	5.3e-20	9.91e-27	1.06e-24	1.38e-24			
f_4	2.1e-11	1.07e-10	8.57e-11	1.41e-14	3.36e-13	2.24e-13			
f_5	3.51e-19	6.95e-18	2.91e-19	5.84e-24	9.33e-23	8.49e-23			
f_6	2.73e-20	4.37e-19	6.19e-19	2.14e-26	5.46e-25	3.11e-25			
f_7	1.90e-32	8.49e-31	7.48e-31	7.92e-35	6.66e-34	4.19e-34			
f_8	9.05e-43	8.96e-42	6.13e-43	2.15e-55	6.33e-54	4.28e-54			
f_9	1.81e-28	2.68e-27	3.49e-27	1.22e-34	5.68e-33	6.50e-33			
f_{10}	1.48e-30	6.49e-27	5.28e-27	9.01e-52	8.40e-50	7.46e-50			
f_{11}	0	0	0	0	0	0			
f_{12}	0	0	0	0	0	0			
f_{13}	2.16e-11	7.27e-10	4.08e-11	7.99e-15	2.51e-13	1.55e-13			
f_{14}	0	0	0	0	0	0			
f_{15}	2.08e-15	8.23e-14	7.49e-14	3.84e-20	1.20e-19	1.13e-20			
f_{16}	0	0	0	0	0	0			
f_{17}	6.20e-12	5.86e-11	5.36e-11	9.83e-14	6.49e-13	7.86e-13			

Table 4: Comparison of various DPGOAs (D=50).

F	GOA			DPGOA1			DPGOA2		
	best	ave	std	best	ave	std	best	ave	std
f_1	8.2e+02	1.5e+03	6.37e+02	4.05e+03	7.06e+03	2.2e+03	3.47	7.23	2.58
f_2	2.52e+01	5.21e+01	3.53e+01	3.41e+01	7.07e+01	3.56e+01	8.64	1.61e+02	9.27e+01
f_3	9.08e+03	1.31e+04	5.1e+03	1.33e+04	1.88e+04	4.09e+03	1.41e+03	4.24e+03	2.68e+03
f_4	1.92e+01	2.22e+01	2.13	1.66e+01	2.64e+01	5.61	2.79e+01	3.45e+01	4.28
f_5	1.43e+04	1.60e+04	2.26e+03	1.21e+04	2.03e+04	8.81e+03	4.72e+03	5.68e+03	904.34
f_6	441.26	569.13	135.50	1.07e+03	1.60e+03	490.77	21.39	26.97	6.96
f_7	8.43e-06	9.03e-06	6.21e-07	2.12e-05	3.73e-05	1.97e-05	1.62e-07	3.41e-07	2.05e-07
f_8	8.90e-04	1.46e-03	7.35e-04	0.13	0.25	0.15	4.35e-07	3.08e-06	3.27e-06
f_9	1.61e+13	3.11e+13	1.33e+13	1.09e+14	5.22e+14	6.86e+14	7.42e+08	5.69e+09	5.59e+09
f_{10}	5.86e-04	6.36e-04	4.66e-05	7.41e-04	1.56e-03	1.11e-03	1.73e-06	1.02e-05	9.92e-06
f_{11}	1.12e+03	1.41e+03	282.99	5.49e+03	6.84e+03	1.23e+03	122.65	154.33	36.56
f_{12}	1.53e+02	1.85e+02	4.0e+01	3.12e+02	3.57e+02	7.67e+01	1.1e+02	2.62e+02	9.81e+01
f_{13}	8.5	1.06e+01	1.33	1.14e+01	1.2e+01	5.6e-01	7.64	8.37	9.23e-01
f_{14}	6.63	1.03e+01	2.56	3.15e+01	5.6e+01	2.16e+01	8.8e-01	1.00	7.34e-02
f_{15}	1.47e+07	2.56e+07	1.55e+07	2.95e+07	8.64e+07	5.83e+07	1.16e+07	1.31e+07	1.30e+06
f_{16}	3.28	3.59	0.37	3.73	3.99	0.32	2.66	3.01	0.31
f_{17}	13.95	15.93	2.62	21.57	26.73	7.57	12.33	22.76	10.49
F	DPGOA3			DPGOA4			DPGOA5		
	best	ave	std	best	ave	std	best	ave	std
f_1	8.74e-14	1.52e-11	2.32e-11	4.93e+03	8.8e+03	3.47e+03	9.37e-16	6.0e-14	1.25e-13
f_2	6.28e-08	1.0e-06	8.81e-07	2.55e+01	7.73e+01	6.7e+01	5.53e-08	3.73e-07	5.72e-07
f_3	2.59e-14	2.43e-10	5.25e-10	3.32e+04	4.18e+04	5.43e+03	2.06e-15	1.12e-12	2.21e-12
f_4	2.71e-08	5.13e-07	6.97e-07	3.74e+01	5.35e+01	1.01e+01	2.33e-08	1.08e-07	1.15e-07
f_5	2.01e-11	7.65e-11	5.81e-11	1.71e+04	2.94e+04	1.11e+04	2.64e-13	5.41e-12	5.03e-12

f_6	2.54e-14	2.29e-12	3.79e-12	463.35	1.79e+03	1.24e+03	6.59e-16	5.09e-14	5.60e-14
f_7	2.37e-21	3.66e-20	3.94e-20	2.41e-05	6.27e-05	4.28e-05	8.73e-27	1.18e-18	2.05e-18
f_8	1.38e-29	6.29e-29	7.21e-29	1.62	10.65	8.13	7.60e-38	5.17e-31	8.94e-31
f_9	1.17e-17	2.54e-16	3.38e-16	4.33e+13	2.67e+14	1.94e+14	5.62e-18	4.27e-16	6.41e-16
f_{10}	2.06e-29	1.19e-21	1.12e-21	3.18e-04	1.40e-02	1.54e-02	9.98e-29	5.85e-21	1.18e-20
f_{11}	0	0	0	8.42e+03	9.78e+03	1.72e+03	0	0	0
f_{12}	0	6.32e-11	1.41e-10	2.04e+02	3.89e+02	1.36e+02	0	1.13e-14	2.54e-14
f_{13}	2.63e-08	3.57e-07	3.18e-07	1.22e+01	1.37e+01	1.84	1.5e-08	9.26e-08	1.2e-07
f_{14}	1.47e-12	5.76e-11	7.12e-11	2.09e+01	4.51e+01	1.93e+01	9.21e-15	2.02e-13	4.0e-13
f_{15}	2.03e-07	7.81e-07	5.85e-07	6.91e+07	1.1e+08	3.85e+07	4.07e-10	1.97e-08	2.89e-08
f_{16}	0	2.96e-16	5.12e-16	3.28	4.12	0.84	0	0	0
f_{17}	8.12e-08	1.97e-07	1.01e-07	37.58	42.27	5.25	1.61e-09	1.78e-08	2.29e-08
F	DPGOA6			DPGOA7					
	best	ave	std	best	ave	std			
f_1	6.91e-21	3.62e-19	5.87e-19	2.78e-27	1.9e-24	1.54e-24			
f_2	3.12e-10	4.5e-10	1.25e-10	7.99e-15	2.65e-13	1.6e-13			
f_3	3.31e-19	2.44e-18	2.16e-18	4.76e-24	1.9e-20	1.54e-20			
f_4	7.71e-11	1.78e-10	1.27e-10	7.99e-15	2.53e-13	1.53e-13			
f_5	4.27e-19	1.91e-18	1.51e-18	2.33e-24	8.09e-23	1.09e-22			
f_6	1.81e-20	4.15e-20	3.6e-20	6.88e-26	2.41e-25	2.44e-25			
f_7	1.76e-33	23.1e-31	3.78e-31	1.43e-34	2.13e-34	9.82e-35			
f_8	5.79e-47	5.61e-46	5.72e-46	4.63e-56	8.97e-56	6.18e-56			
f_9	8.17e-29	3.54e-28	3.31e-28	8.41e-32	1.68e-31	1.19e-31			
f_{10}	2.62e-42	9.77e-38	1.69e-37	2.78e-54	3.04e-40	4.30e-40			
f_{11}	0	0	0	0	0	0			
f_{12}	0	0	0	0	0	0			
f_{13}	2.3e-11	5.67e-11	2.51e-11	7.96e-15	2.31e-13	1.36e-13			
f_{14}	0	0	0	0	0	0			
f_{15}	7.16e-16	5.24e-15	4.07e-15	1.16e-19	1.77e-19	8.65e-20			
f_{16}	0	0	0	0	0	0			
f_{17}	3.83e-12	2.64e-11	2.53e-11	1.71e-15	4.78e-14	6.53e-14			

It can be concluded from the table that with the increase of dimensions, GOA's optimization results become worse, falling into the disaster of dimensions. It is proved that GOA can only perform when the optimization problem is of low dimensions. Once the dimensions are increased, it shows the shortcoming of poor stability of GOA. However, with the increase of dimensions, the optimization accuracy of DPGOA7 has hardly changed, and its robustness is strong. It is proved that the proposed DPGOA7 strategy combination of DA, CD and GM can make the algorithm obtain more stable results in the optimization problem. In this paper, three improved strategies and their random combinations improve the algorithm in different degrees. With the increase of dimensions, DPGOA1-3 has the situation of "dimension disaster", indicating that these three strategies have certain improvement effects when applied separately, but not so significant. For DPGOA4, its robustness is not as strong as DPGOA5 and DPGOA6, indicating that the combination strategy of DA and CD is not as significant as the improvement effect of other two random combinations. Compared with DPGOA1-6, DPGOA7 achieve the most significant results on all 17 benchmark functions, and the increase of dimension does not affect the optimization accuracy of DPGOA7. The proposed DPGOA7 shows stability of performance, indicating that the combination of the three strategies can significantly improve the optimization performance of GOA in optimization problems. In the subsequent section, DPGOA is used to refer to DPGOA7 here.

Comparisons of DPGOA with Other Methods

In this experiment, the performance of the proposed DPGOA is compared with five other state-of-art optimization algorithms, including basic GOA, Dragonfly Algorithm (DA) (Mirjalili, 2016), Moth-flame Optimization (MFO) (Mirjalili, 2015), Sine-Cosine Algorithm (SCA) (Mirjalili, 2016) and Salp Swarm Algorithm (SSA) (Faris *et al.*, 2018) on 17 optimization problems. Table 5 shows the parameter settings of all comparison algorithms. The optimization results of the six algorithms to the benchmark function are shown in the Tables 6 to 8.

Table 5: The parameter settings of all comparison algorithms.

Algorithm	The parameter setting	The general setting
The proposed DPGOA	$c_{max} = 1$	The population size

Grasshopper optimization algorithm(GOA)	$c_{min} = 0.00001$ $k = 0.1$ $c_{max} = 1$ $c_{min} = 0.00001$	$N = 30$ The maximum iterations $t_{max} = 500$.
Dragonfly Algorithm(DA)	$w_{max} = 0.9$ $w_{min} = 0.4$	
Moth-flame Optimization(MFO)	$b = 1$	
Sine-Cosine Algorithm	$a = 2$	
Salp Swarm Algorithm(SSA)	$c_2, c_3 \in (0, 1)$	

Table 6: Comparison results of the methods involved in this study. (D=10)

F	DPGOA			GOA			DA		
	best	ave	std	best	ave	std	best	ave	std
f_1	1.63e-28	4.65e-25	5.27e-25	5.96e-07	2.48e-06	2.75e-06	1.02e-02	1.23e+01	1.32e+01
f_2	2.75e-14	1.54e-13	9.72e-14	4.5e-04	2.52e-03	2.18e-03	5.71e-02	1.49	1.22
f_3	1.86e-25	1.18e-24	7.32e-25	2.85e-01	1.96	2.1	1.17e+01	1.36e+02	1.76e+02
f_4	5.56e-15	5.16e-13	4.47e-13	7.82e-03	4.41e-02	2.12e-02	1.25	2.52	1.27
f_5	1.46e-25	3.13e-24	4.22e-24	2.75e-02	1.13	1.30	62.04	330.49	358.14
f_6	3.62e-27	2.98e-26	2.82e-26	6.41e-07	5.59e-06	4.97e-06	2.0e-03	1.28	1.22
f_7	2.27e-33	1.36e-32	1.41e-32	1.08e-06	4.65e-06	3.02e-06	1.24e-06	1.32e-05	1.74e-05
f_8	1.17e-58	1.32e-57	2.24e-57	9.24e-20	1.57e-17	3.20e-17	7.36e-07	1.87e-05	1.42e-05
f_9	9.75e-36	2.07e-31	2.86e-31	1.12e+03	3.95e+03	3.17e+03	2.12e+06	1.41e+09	1.86e+09
f_{10}	1.35e-52	1.69e-48	3.81e-48	2.15e-07	7.24e-07	4.04e-07	5.93e-06	4.78e-05	8.17e-05
f_{11}	0	0	0	0	1.40	1.34	7.02	47.2	70.26
f_{12}	0	0	0	1.09e+01	2.85e+01	1.54e+01	3.39e+01	3.72e+01	3.11
f_{13}	1.99e-13	3.28e-13	1.2e-13	5.93e-04	9.25e-01	9.68e-01	1.15	3.44	2.07
f_{14}	0	0	0	2.7e-01	3.25e-01	5.23e-02	1.11e-01	6.97e-01	4.21e-01
f_{15}	2.53e-21	1.28e-20	1.16e-20	5.37e+05	1.12e+06	4.68e+05	5.02e+04	1.92e+06	3.86e+06
f_{16}	0	0	0	0.15	0.62	0.35	6.7e-03	0.23	0.24
f_{17}	3.85e-15	1.19e-14	8.87e-15	4.19e-02	0.48	0.42	0.73	2.33	1.45
F	MFO			SCA			SSA		
	best	ave	std	best	ave	std	best	ave	std
f_1	3.9e-15	2.85e-13	3.63e-13	3.55e-14	5.54e-13	1.06e-12	6.34e-10	1.12e-09	3.28e-10
f_2	1.25e-09	4.0	5.47	8.17e-12	5.88e-10	1.15e-09	8.21e-06	1.48e-01	2.5e-01
f_3	4.58e-03	1.0e+03	2.23e+03	9.87e-08	1.04e-03	2.29e-03	2.16e-09	1.26e-06	2.77e-06
f_4	1.4e-03	9.89e-02	7.48e-02	8.87e-06	5.85e-04	9.87e-04	1.54e-05	2.14e-05	5.11e-06
f_5	1.60e-04	0.13	0.31	4.81e-08	4.3e-03	1.21e-02	1.62e-09	4.49e-07	8.26e-07
f_6	2.94e-16	2.28e-14	3.20e-14	1.04e-18	4.51e-13	1.37e-12	5.03e-11	1.06e-10	6.91e-11
f_7	4.06e-37	1.51e-33	3.13e-33	2.11e-35	2.57e-29	8.14e-29	1.06e-07	4.95e-07	3.31e-07
f_8	3.49e-30	9.79e-24	3.09e-23	2.83e-35	1.07e-23	2.17e-23	8.84e-27	3.60e-26	3.16e-26
f_9	9.23e-21	4.0e+03	5.16e+03	1.94e-25	8.11e-14	2.56e-13	56.65	1.56e+03	1.31e+03
f_{10}	4.45e-36	3.12e-33	4.27e-33	2.62e-44	4.69e-30	1.48e-29	9.0e-08	5.37e-07	4.13e-07
f_{11}	0	0	0	0	0	0	0	1.43	1.26
f_{12}	7.95	1.73e+01	8.99	0	1.66	3.72	7.95	1.33e+01	3.26
f_{13}	5.31e-08	1.31e-07	6.35e-08	2.47e-09	7.38e-07	1.15e-06	1.08e-05	2.31e-01	5.16e-01
f_{14}	5.9e-02	2.25e-01	2.87e-01	1.52e-05	1.35e-01	2.85e-01	8.37e-02	1.77e-01	1.57e-01
f_{15}	8.97e-12	1.37e+05	3.95e+05	5.54e-14	2.67e-09	7.63e-09	3.49e+04	5.25e+05	4.28e+05
f_{16}	0	2.96e-02	6.23e-02	0	7.83e-15	1.46e-14	1.07e-12	0.26	0.17
f_{17}	9.07e-11	0.44	1.40	9.31e-10	1.45e-06	3.63e-06	7.94e-02	0.35	0.29

Table 7: Comparison results of the methods involved in this study. (D=30)

F	DPGOA			GOA			DA		
	best	ave	std	best	ave	std	best	ave	std

f_1	2.33e-26	1.89e-24	3.6e-24	6.23	3.31e+01	2.28e+01	4.96e+02	1.93e+03	9.98e+02
f_2	8.01e-14	4.67e-13	3.43e-13	2.99	1.45e+01	1.65e+01	9.64e-01	1.49e+01	6.13
f_3	4.06e-27	1.01e-23	1.16e-23	9.67e+02	3.61e+03	1.75e+03	2.03e+03	1.52e+04	9.2e+03
f_4	4.63e-14	3.34e-13	2.43e-13	7.77	1.48e+01	4.2	1.59e+01	3.14e+01	9.54
f_5	7.37e-24	1.77e-23	1.69e-23	1.12e+03	2.18e+03	924.71	330.04	1.51e+04	1.12e+04
f_6	5.22e-27	2.84e-26	3.49e-26	27.74	44.97	17.98	49.43	187.48	117.43
f_7	2.31e-35	1.93e-34	2.86e-34	1.36e-06	3.91e-06	2.26e-06	2.01e-06	1.25e-04	1.40e-04
f_8	1.22e-56	1.43e-56	2.72e-57	2.32e-06	2.93e-06	5.29e-07	1.07e-02	0.26	0.25
f_9	7.94e-36	2.44e-29	2.19e-29	2.72e+08	3.26e+10	4.43e+10	4.09e+13	1.51e+14	1.15e+14
f_{10}	2.13e-52	2.07e-35	3.56e-35	7.69e-05	8.75e-05	9.78e-06	5.93e-04	1.3e-03	7.19e-04
f_{11}	0	0	0	92.13	122.34	34.58	1.79e+03	2.38e+03	837.03
f_{12}	0	0	0	3.26e+01	9.1e+01	2.87e+01	1.24e+02	1.73e+02	3.28e+01
f_{13}	2.93e-14	2.27e-13	2.14e-13	2.84	5.53	1.64	6.94	1.03e+01	1.9
f_{14}	0	0	0	9.07e-01	1.15	1.17e-01	7.73	1.71e+01	6.72
f_{15}	9.12e-20	2.88e-19	3.01e-19	8.41e+06	1.28e+07	7.03e+06	4.62e+06	2.03e+07	1.53e+07
f_{16}	0	0	0	1.18	1.36	0.23	1.42	2.45	0.77
f_{17}	6.31e-15	4.56e-14	6.52e-14	4.50	9.9	6.53	5.89	15.09	8.12
F	MFO			SCA			SSA		
	best	ave	std	best	ave	std	best	ave	std
f_1	5.96e-01	2.0e+03	4.83e+03	3.16e-03	1.23e+01	3.38e+01	2.82e-08	2.65e-07	4.11e-07
f_2	9.1e-02	3.07e+01	2.14e+01	2.0e-04	1.4e-02	1.87e-02	1.68e-01	2.08	1.85
f_3	2.17e+03	2.14e+04	1.27e+04	6.5e+02	1.04e+04	7.52e+03	3.78e+02	1.54e+03	1.07e+03
f_4	5.42e+01	6.93e+01	6.39	9.26	3.23e+01	1.15e+01	5.27	1.12e+01	3.43
f_5	9.07e+03	2.11e+04	9.66e+03	3.85e+03	8.69e+03	4.95e+03	499.32	1.83e+03	1.12e+03
f_6	0.36	550.20	670.32	1.98e-02	0.88	1.53	1.8e-03	2.03	3.09
f_7	2.48e-12	4.0e-10	7.75e-10	8.92e-11	4.54e-06	8.96e-06	4.54e-07	1.94e-06	1.12e-06
f_8	1.82e-05	2.14	4.34	2.75e-05	1.71e-02	2.46e-02	7.22e-17	1.17e-13	3.52e-13
f_9	1.14e+09	5.86e+11	1.72e+12	1.45e+09	3.71e+14	8.92e+14	11.90	765.20	1.22e+03
f_{10}	2.93e-09	1.55e-06	4.36e-06	1.55e-09	5.04e-05	5.51e-05	8.23e-06	1.72e-05	6.63e-06
f_{11}	2.0	1.03e+03	3.16e+03	0	14.20	20.25	6.0	16.1	5.97
f_{12}	8.7e+01	1.6e+02	3.77e+01	6.9e-02	4.11e+01	3.47e+01	2.88e+01	5.78e+01	2.1e+01
f_{13}	1.82	1.45e+01	6.96	4.94e-02	1.22e+01	8.94e	9.31e-01	2.52	8.6e-01
f_{14}	5.2e-01	2.49e+01	5.25e+01	2.03e-01	1.03	5.01e-01	1.32e-03	2.01e-02	1.48e-02
f_{15}	8.56e+05	2.69e+07	2.89e+07	31.27	583.16	835.59	2.35e+06	6.11e+06	3.75e+06
f_{16}	0.15	0.61	0.23	1.30e-05	3.8e-03	8.80e-03	0.44	1.03	0.33
f_{17}	2.58e-02	8.24	8.82	2.1e-03	0.81	1.22	1.73	3.46	1.59

Table 8: Comparison results of the methods involved in this study. (D=50)

F	DPGOA			GOA			DA		
	best	ave	std	best	ave	std	best	ave	std
f_1	7.61e-26	2.76e-24	3.42e-24	3.59e+01	6.63e+02	7.58e+02	2.97e+03	5.59e+03	2.43e+03
f_2	3.39e-13	8.83e-13	4.06e-13	9.4e+01	3.65e+02	4.12e+02	1.46	1.82e+01	1.13e+01
f_3	6.42e-27	5.35e-24	6.12e-24	9.67e+03	1.61e+04	6.75e+03	5.13e+03	1.49e+04	9.88e+03
f_4	2.48e-14	1.23e-13	2.15e-13	1.36e+01	1.4e+01	2.21	1.46e+01	2.74e+01	8.97
f_5	3.53e-24	7.69e-23	1.12e-22	1.07e+04	1.31e+04	2.29e+03	7.99e+03	4.69e+04	3.11e+04
f_6	7.13e-26	2.46e-25	1.99e-25	337.43	391.53	83.92	841.21	1.73e+03	1.21e+03
f_7	1.34e-34	2.96e-34	9.67e-35	2.18e-06	5.31e-06	2.92e-06	5.91e-06	3.33e-05	1.96e-05
f_8	5.13e-56	9.17e-56	6.03e-56	5.77e-04	1.2e-03	6.28e-04	0.51	1.56	0.85
f_9	7.98e-32	1.66e-31	1.12e-31	1.45e+13	2.06e+13	5.46e+12	3.66e+14	1.21e+15	7.87e+14
f_{10}	2.78e-54	3.11e-42	4.16e-41	2.25e-04	3.66e-04	2.12e-04	5.30e-03	1.28e-02	1.07e-02
f_{11}	0	0	0	1.52e+03	2.99e+03	1.37e+03	4.63e+03	7.26e+03	2.65e+03
f_{12}	0	0	0	3.26e+01	1.1e+02	8.17e+01	1.49e+02	1.98e+02	4.68e+01
f_{13}	8.13e-14	4.68e-13	3.18e-13	8.19	1.32e+01	1.64	7.44	1.32e+01	2.64

f_{14}	0	0	0	7.03	1.65e+01	2.11	8.02	1.89e+01	7.45
f_{15}	1.13e-19	1.49e-19	8.93e-20	2.08e+07	4.43e+07	3.71e+07	3.72e+07	7.27e+07	3.71e+07
f_{16}	0	0	0	2.65	3.17	0.54	3.22	5.09	1.40
f_{17}	1.65e-15	4.83e-14	6.71e-14	9.40	17.99	10.64	27.70	31.68	3.29
F	MFO			SCA			SSA		
	best	ave	std	best	ave	std	best	ave	std
f_1	8.01e+02	1.51e+04	1.52e+04	2.78e+01	8.83e+02	8.55e+02	2.03e-01	6.73e-01	4.96e-01
f_2	4.32e+01	9.99e+01	5.14e+01	3.0e-01	1.91	1.48	6.24	1.36e+01	7.18
f_3	4.7e+04	6.97e+04	2.31e+04	3.62e+04	4.81e+04	9.82e+03	2.76e+03	7.33e+03	3.66e+03
f_4	7.92e+01	8.56e+01	4.0	5.29e+01	6.74e+01	9.72	1.32e+01	1.91e+01	5.42
f_5	3.73e+04	6.68e+04	2.39e+04	3.81e+04	5.36e+04	8.90e+03	3.39e+03	9.29e+03	5.72e+03
f_6	590.99	2.263+03	1.91e+03	8.68	93.71	67.73	10.15	22.42	15.33
f_7	5.93e-08	3.85e-06	5.82e-06	1.21e-04	7.6e-03	1.29e-02	4.93e-07	3.89e-06	4.25e-06
f_8	0.23	19.09	17.18	2.68e-02	3.92	3.81	9.13e-08	5.99e-05	5.65e-05
f_9	6.96e+14	3.62e+15	3.45e+15	7.95e+15	1.25e+17	2.29e+17	4.54e+08	8.19e+09	8.43e+09
f_{10}	3.57e-04	0.11	0.31	5.04e-04	5.65e-02	5.87e-02	6.94e-05	1.31e-04	7.33e-05
f_{11}	386.0	9.95e+03	1.08e+04	49.1	1.55e+03	1.65e+03	61.1	121.7	48.6
f_{12}	2.76e+02	3.45e+02	6.49e+01	1.7e+01	1.11e+02	6.62e+01	5.97e+01	9.39e+01	2.43e+01
f_{13}	1.37e+01	1.79e+01	2.52	1.75e+01	1.98e+01	1.31	2.48	4.9	2.02
f_{14}	6.09	9.69e+01	5.68e+01	1.42	5.51	3.82	1.89e-01	5.18e-01	3.18e-01
f_{15}	3.18e+07	2.77e+08	1.89e+08	5.68e+03	2.04e+05	2.41e+05	9.50e+06	2.07e+07	1.71e+07
f_{16}	1.38	1.99	0.56	1.08e-02	0.40	0.70	1.33	2.13	0.58
f_{17}	1.75	10.31	6.03	0.36	5.26	3.71	5.57	9.09	3.36

Tables 6 to 8 show the comparisons between the proposed DPGOA and the comparison algorithms in different dimensions (when $D=10, 30,$ and 50). It can be seen that the fitness values of the unimodal functions (f_1-f_{11}) and the multimodal functions ($f_{12}-f_{17}$) are significantly higher than those of other algorithms, proving that the three improved mechanisms in DPGOA have superior performance in the recent emerging algorithms. With the increase of dimensions, the optimization accuracy of DPGOA also remains stable. Other comparison algorithms have gradually lost the optimization ability to varying degrees, and the optimization accuracy obviously cannot achieve the ability of optimization problem. For f_{11}, f_{12}, f_{14} and f_{16} , the proposed DPGOA can converge to the theoretical optimal value, and even the SSA algorithm with the best performance among all the comparison algorithms still fails to achieve better optimization performance.

Convergence Curve Analysis

Fig. 3 shows the part of the convergence curve of the proposed DPGOA and other comparison algorithms on the benchmark functions when $D=30$. It can be seen from the figure that the proposed DPGOA has the best convergence in all the functions. When other algorithms fall into the local optimal situation, DPGOA has the ability to jump out of the local optimal and maintain search ability. The convergence result shows that the proposed three strategies can significantly improve the convergence of DPGOA.

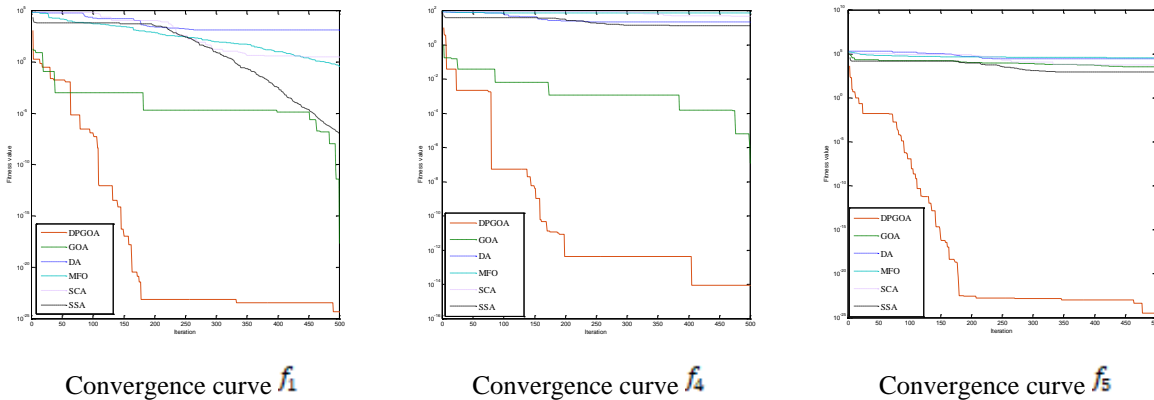

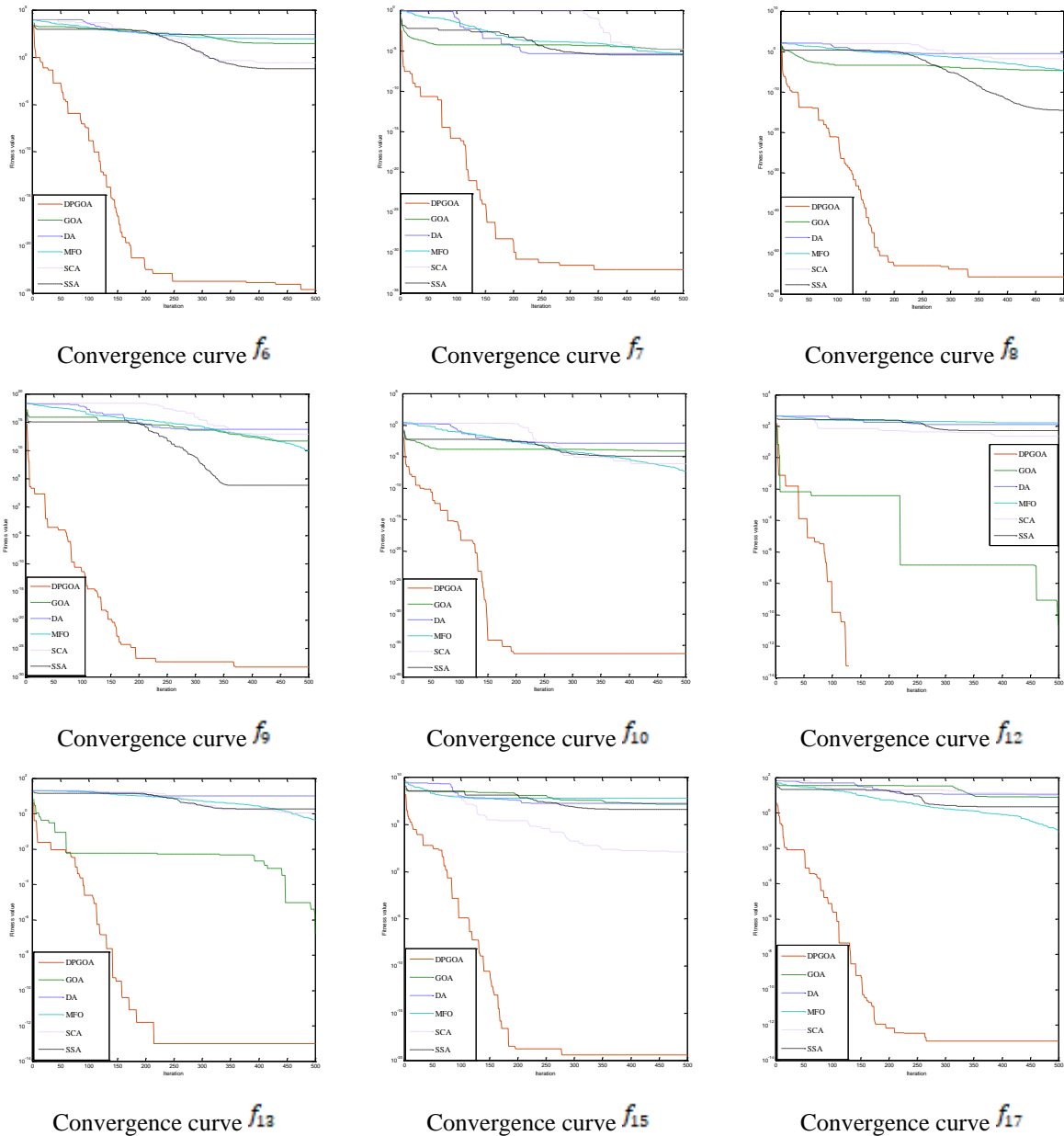

Source: This study.
 Figure 3: Convergence curve for the six algorithms for benchmark functions.

The Scalability Test

In this section, scalability tests will be performed to test the effectiveness of DPGOA compared to other approaches. For the results obtained in Section 4.3-4.4, IBM SPSS Statistics 22 was used for Friedman test and Wilcoxon rank-sum test. The significance level was set at 5%. When $p\text{-values} < 0.05$, it is a statistically significant difference between the results of DPGOA and the comparison method. When $p\text{-values} > 0.05$, there is no statistically significant difference between these methods.

The Friedman test result of DPGOA7 and DPGOA1-6

In Table 2-4 from Section 4.3, Friedman test was conducted on the random combination of the three improved strategies and the average value of the results of 30 independent runs of the original GOA. The results can be seen from the comparison between the random combination of DPGOA1-DPGOA7 and the original GOA:

When $D=10$, the average rank of the algorithms in Table 8 is 6.06(GOA), 6.47(DPGOA1), 6.12(DPGOA2), 3.62(DPGOA3), 6.76(DPGOA4), 3.03(DPGOA5), 2.09(DPGOA6) and 1.85(DPGOA7), the priority order is as follows: DPGOA7>DPGOA6>DPGOA5>DPGOA3>GOA>DPGOA2>DPGOA1>DPGOA4.

When D=30, the average rank of the algorithms in Table 9 is 6.12(GOA), 6.94(DPGOA1), 5.41(DPGOA2), 3.47(DPGOA3), 7.53(DPGOA4), 2.82(DPGOA5), 2.00(DPGOA6) and 1.71(DPGOA7), the priority order is DPGOA7>DPGOA6>DPGOA5>DPGOA3>DPGOA2>GOA>DPGOA1>DPGOA4.

When D=50, the average rank of the algorithms in Table 10 is 5.76(GOA), 7.00(DPGOA1), 5.41(DPGOA2), 3.47(DPGOA3), 7.82(DPGOA4), 2.82(DPGOA5), 1.97(DPGOA6), 1.74(DPGOA7), the priority order is DPGOA7>DPGOA6>DPGOA5>DPGOA3>DPGOA2>GOA>DPGOA1>DPGOA4.

The Friedman test result of DPGOA and comparison methods

Take the mean value of 30 independent runs of DPGOA and other emerging algorithms in Table 6-8 from Section 4.4 for Friedman test. The results show that DPGOA is compared with other emerging algorithms:

When D=10, the average rank of the algorithms in Table 11 is 1.32(DPGOA), 4.59(GOA), 5.76(DA), 3.47(MFO), 2.38(SCA), 3.47(SSA), and the priority order is DPGOA>SCA>SSA>MFO>GOA>DA.

When D=30, the average rank of the algorithms in Table 12 is 1.00(DPGOA), 3.82(GOA), 5.24(DA), 5.00(MFO), 3.35(SCA), 2.59(SSA), and the priority order is DPGOA>SSA>SCA>GOA>MFO>DA.

When D=50, the average rank of the algorithms in Table 13 is 1.00(DPGOA), 3.68(GOA), 4.50(DA), 5.53(MFO), 3.94(SCA), 2.35(SSA), and the priority order is DPGOA>SSA>GOA>SCA>DA>MFO.

Wilcoxon rank sum test was applied to verify the numerical results in Table 3 and Table 7, as shown in Table 9 and Table 10. When the p-values<0.05, there is a significant difference with other test methods, otherwise, there is no significant difference.

Table 9: The rank-order results of Table 3.

Algorithm	P-value	h
DPGOA7 vs GOA	6.91e-07	1
DPGOA7 vs DPGOA1	6.91e-07	1
DPGOA7 vs DPGOA2	6.91e-07	1
DPGOA7 vs DPGOA3	4.93e-04	1
DPGOA7 vs DPGOA4	6.91e-07	1
DPGOA7 vs DPGOA5	1.56e-02	1
DPGOA7 vs DPGOA6	0.41	0

Table 10: The rank-order results of Table 7.

Algorithm	P-value	h
DPGOA7 vs GOA	6.91e-07	1
DPGOA7 vs DA	6.91e-07	1
DPGOA7 vs MFO	6.91e-07	1
DPGOA7 vs SCA	6.91e-07	1
DPGOA7 vs SSA	1.17e-07	1

It can be seen from Table 9 that, DPGOA6 and DPGOA7 has no significant difference in the random combination of the three improved strategies, but the convergence precision of DPGOA7 is slightly better than DPGOA6. Table 10 shows that in the comparison between DPGOA and other emerging algorithms, all p-value<0.05 represents the significant difference between DPGOA and other algorithms, which is the same as the results of Friedman's test. From the above extended tests, it can be seen that DPGOA has a statistically significant difference in the random combination of improved strategies and other algorithms, and has a better ability to optimize problems.

DPGOA FOR ENGINEERING DESIGN PROBLEMS

The application of engineering problems is a method to verify the performance of the proposed algorithm, which provides a direction for the application of the proposed algorithm in the future. In this section, two constrained engineering design problems were performed to verify the efficiency and performance of the proposed DPGOA: three-bar truss design problem and welded beam design problem. For DPGOA, the population size N=30, the number of iterations t_{max} =500.

Three-bar Truss Design Problem

The optimization goal of three-bar truss design problem is to minimize the weight of the truss by calculating the optimal value of two key parameters A_1, A_2 . Fig. 4 shows the structural drawing of the truss and its parameters. The mathematical form of three-bar truss design problem is as follows:

$$\begin{aligned} \text{Consider} \quad & \vec{x} = [x_1 \ x_2] = [A_1 \ A_2], \\ \text{Minimize} \quad & f(\vec{x}) = L \times (2\sqrt{2}x_1 + x_2), \end{aligned}$$

Subject to $g_1(\vec{x}) = \frac{\sqrt{2}x_1 + x_2}{\sqrt{2}x_1^2 + 2x_1x_2} P \leq \sigma,$

$g_2(\vec{x}) = \frac{x_2}{\sqrt{2}x_2 + x_1} P \leq \sigma,$

Variable range $0.01 \leq x_1 \leq 1, 0.01 \leq x_2 \leq 1,$

Where $L = 100 \text{ cm}, P = 2 \text{ km/cm}^2, \sigma = 2 \text{ km/cm}^2.$

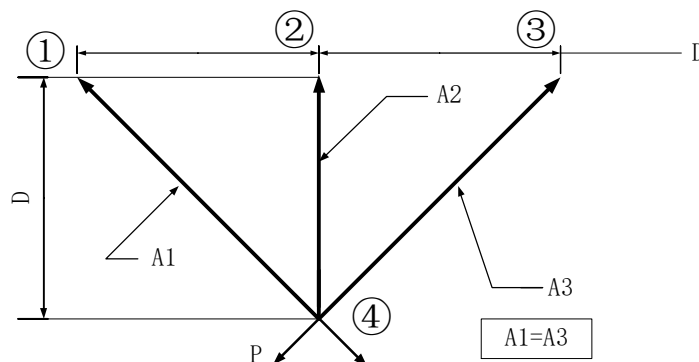

Source: This study.
Figure 4: Schematic of Three-bar truss design problem.

To evaluate the performance of the proposed DPGOA in solving three-bar truss design problem, the results are compared with the following methods: the original GOA, Cuckoo Search (CS) (Gandomi, 2013), Ray and Saini(Ray & Saini, 2001), and Tsai(Tsai, 2005). Table 16 shows that the result of three-bar truss design problem and the key parameters of the optimal cost obtained by the proposed DPGOA.

Table 11 shows the results of the proposed DPGOA compared with other methods, the proposed DPGOA is more competitive than other algorithm. The optimal solution of the three-bar truss problem is 263.9029 by DPGOA, and two parameters are 0.78972 and 0.40636.

Table 11: Comparison of result on three-bar truss design problem.

Method	Optimal values for variables		Optimal cost
	x_1	x_2	
DPGOA	0.78972	0.40636	263.9029
GOA	0.77863	0.43893	264.1221
CS	0.78867	0.40902	263.9716
Ray and Saini	0.795	0.395	264.3
Tsai	0.788	0.408	263.68

Welded Beam Design Problem

In this section, welded beam design problem (Coello, 2000) was used to test the performance of the proposed DPGOA. Welded beam design problem is to minimize the fabrication cost by calculating the optimal value of four key parameters as shown in Fig.5. The four key parameters are thickness of the bar (b), thickness of the weld (h), height of the bar (t), and length of attached part of bar (l). The mathematical form of welded beam design problem is as follows:

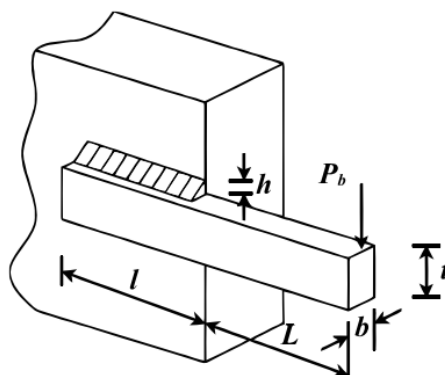

Source: This study.
Figure 5: Schematic of welded beam design problem.

Consider $\vec{x} = [x_1 \ x_2 \ x_3 \ x_4] = [h \ l \ t \ b]$,
 Minimize $f(\vec{x}) = 1.10471x_1^2x_2 + 0.04811x_3x_4(14.0 + x_2)$,
 Subject to $g_1(\vec{x}) = \tau(\vec{x}) - \tau_{max} \leq 0$,
 $g_2(\vec{x}) = \sigma(\vec{x}) - \sigma_{max} \leq 0$,
 $g_3(\vec{x}) = \delta(\vec{x}) - \delta_{max} \leq 0$,
 $g_4(\vec{x}) = x_1 - x_4 \leq 0$,
 $g_5(\vec{x}) = p - p_c(\vec{x}) \leq 0$,
 $g_6(\vec{x}) = 0.125 - x_1 \leq 0$,
 $g_7(\vec{x}) = 1.10471x_1^2 + 0.04811x_3x_4(14.0 + x_2) - 5 \leq 0$,
 Variable range $0.1 \leq x_1 \leq 2, 0.1 \leq x_2 \leq 10, 0.1 \leq x_3 \leq 10, 0.1 \leq x_4 \leq 2$,
 Where $\tau(\vec{x}) = \sqrt{(\tau')^2 + 2\tau'\tau''\frac{x_2}{2R} + (\tau'')^2}, \tau' = \frac{P}{\sqrt{2}x_1x_2}, \tau'' = \frac{MR}{J}$
 $M = P(L + \frac{x_2}{2}), R = \sqrt{\frac{x_2^2}{4} + (\frac{x_1+x_3}{2})^2}, J = 2\{\sqrt{2}x_1x_2[\frac{x_2^2}{4} + (\frac{x_1+x_3}{2})^2]\}$,
 $\sigma(\vec{x}) = \frac{6PL}{x_4x_3^2}, \delta(\vec{x}) = \frac{6PL^3}{Ex_4x_3^2}$,
 $p_c(\vec{x}) = \frac{4.013E\sqrt{\frac{x_3^2x_4^6}{36}}}{L^2}\left(1 - \frac{x_3}{2L}\sqrt{\frac{E}{4G}}\right)$,
 $P = 6000lb, L = 14 \text{ in.}, \delta_{max} = 0.25in.$
 $E = 30 \times 10^6 \text{ psi}, G = 12 \times 10^6 \text{ psi},$
 $\tau_{max} = 13600 \text{ psi}, \sigma_{max} = 30000 \text{ psi}.$

The four key parameters and optimal values of the welded beam design problem are estimated by the proposed DPGOA, and the results are compared with eleven methods: Genetic Algorithm (GA) (Deb, 2000), Particle Swarm Optimization (PSO) (He *et al.*, 2004), Interior Search Algorithm (ISA) (Gandomi, 2014), Tree-seed Algorithm (TSA) (Babalik *et al.*, 2018), Harmony Search(Lee & Geem, 2005), Simulated Annealing Processing(Atiqullah & Rao, 2000), Socio-behavioural Simulation Model(Akhtar *et al.*, 2002), Novel Orthogonal Simulated Annealing (Liu, 2005), Derivative-free Filter Simulated Annealing (Hedar & Fukushima, 2006) and Effective Multiagent Evolutionary Algorithm(Zhang *et al.*, 2009). The solution is reported in Table 17, the DPGOA optimal solution of each function is bold.

Table 12 shows the comparison of the proposed DPGOA with the results of the other 11 methods, indicating that the proposed DPGOA outperform the other algorithm in solving the welded beam design problem. The optimal value obtained by the proposed DPGOA is 1.8043, the four parameters are set as h=0.20305, l=4.0429, t=9.0802, b=0.20556.

Table 12: Comparison of result on welded beam design problem

Method	Optimal values for variables				Optimal cost
	x_1	x_2	x_3	x_4	
DPGOA	0.20305	4.0429	9.0802	0.20556	1.8043
GA	0.2489	6.1730	8.1789	0.2533	2.4331
IPSO	0.2444	6.2175	8.2915	0.2444	2.3810
ISA	0.2443	6.2199	8.2915	0.2443	2.3812
MTSA	0.24415742	6.22306595	8.29555011	0.24440474	2.38241101
HS	0.2442	6.2331	8.2915	0.2443	2.3807
SA	0.2471	6.1451	8.2721	0.2495	2.4148
SBM	0.2407	6.4851	8.2399	0.2497	2.4426
NOSA	0.2444	6.2175	8.2915	0.2444	2.3810
DFSA	0.2444	6.2152	8.2939	0.2444	2.3811
EMEA	0.2443	6.2201	8.2940	0.2444	2.3816

CONCLUSION

This paper presents an improved GOA called DPGOA, which employed dynamic attenuation adjustment factor, Cauchy mutation, and Gaussian mutation to enhance the global and the local exploration capabilities of original GOA. 17 classical benchmark functions are used to verify the effectiveness of the improved method. Experimental study of the effects of these three strategies on the performance of DPGOA revealed that the dynamic attenuation adjustment factor strategy has a crucial influence on the improvement of the performance of DPGOA and the performance of original GOA can be significantly improved by properly combining all three strategies. Second, compared with the well-known algorithms, such as DA, MFO, GOA, SCA and SSA,

DPGOA perform a relatively good performance. DPGOA has faster convergence speed and with a relatively high stability, and can provide more competitive results on the 17 classical benchmark functions. In addition, The Friedman test and Wilcoxon rank sum test were used for significance analysis of the algorithms and obtained competitive results. Finally, two real-world engineering problems are also applied to demonstrate the performance of the DPGOA. The results of DPGOA on the three-bar truss design problem and the welded beam design problem show that DPGOA have the vastly potential ability to solve real-world problems as well.

Although the proposed DPGOA was proved to perform effectively on function optimization and engineering design problems, there are some potential direction can be reference in the future work: Because of the search mechanism of GOA algorithm extend the time of the calculation of the algorithm, there are certain limitations in solving high-dimension optimization problems. The research on the search mechanism of DPGOA algorithm is in prospect. Therefore, the combination of the proposed DPGOA and other intelligent optimization algorithms is also a worthwhile research direction. Additionally, the proposed methods in this algorithm be applied to multi-objective problems, constrained and unconstrained optimization problems, and solving more complex real-world engineering problems may be focused for further work.

ACKNOWLEDGMENT

This study is supported by the National Natural Science Foundation of China (No. 71601071), the Science & Technology Program of Henan Province, China (No. 182102310886 and 162102110109), MOE Youth Foundation Project of Humanities and Social Sciences (No. 15YJC630079) and the Postgraduate Meritocracy Scheme (No. SYL19060145) of Henan University.

REFERENCES

- [1] Arora, S., & Anand, P. (2019). Chaotic grasshopper optimization algorithm for global optimization. *Neural Computing and Applications*, 31(8), 4385-4405. doi: 10.1007/s00521-018-3343-2
- [2] Barman, M., Choudhury, N. D., & Sutradhar, S. (2018). A regional hybrid GOA-SVM model based on similar day approach for short-term load forecasting in Assam, India. *Energy*, 145, 710-720. doi: 10.1016/j.energy.2017.12.156
- [3] Brownlee, J. (2011). *Clever Algorithms: Nature-Inspired Programming Recipes*. Jason Brownlee.
- [4] Crawford, B., Soto, R., Peña, A., & Astorga, G. (2018, April). A binary grasshopper optimisation algorithm applied to the set covering problem. In *Computer Science On-line Conference* (pp. 1-12). Springer, Cham. doi: 10.1007/978-3-319-91192-2_1
- [5] Dhiman, G., & Kumar, V. (2018). Emperor penguin optimizer: A bio-inspired algorithm for engineering problems. *Knowledge-Based Systems*, 159, 20-50. doi: 10.1016/j.knsys.2018.06.001
- [6] Dorigo, M., Birattari, M., & Stutzle, T. (2006). Ant colony optimization - Artificial ants as a computational intelligence technique. *IEEE Computational Intelligence Magazine*, 1(4), 28-39. doi: 10.1109/MCI.2006.329691
- [7] Dorigo, M., Maniezzo, V., & Colomi, A. (1996). Ant system: optimization by a colony of cooperating agents. *IEEE Transactions on Systems, Man, and Cybernetics, Part B (Cybernetics)*, 26(1), 29-41. doi: 10.1109/3477.484436
- [8] Eberhart, R., & Kennedy, J. (1995, October). A new optimizer using particle swarm theory. In *MHS'95. Proceedings of the Sixth International Symposium on Micro Machine and Human Science* (pp. 39-43). IEEE. doi: 10.1109/MHS.1995.494215
- [9] El-Fergany, A. A. (2017). Electrical characterisation of proton exchange membrane fuel cells stack using grasshopper optimiser. *IET Renewable Power Generation*, 12(1), 9-17. doi: 10.1049/iet-rpg.2017.0232
- [10] Ewees, A. A., Abd Elaziz, M., & Houssein, E. H. (2018). Improved grasshopper optimization algorithm using opposition-based learning. *Expert Systems with Applications*, 112, 156-172. doi: 10.1016/j.eswa.2018.06.023
- [11] Jeong, Y. W., Park, S. M., Geem, Z. W., & Sim, K. B. (2020). Advanced Parameter-Setting-Free Harmony Search Algorithm. *Applied Sciences*, 10(7), 2586. doi: 10.3390/app10072586
- [12] Jumani, T. A., Mustafa, M. W., Md Rasid, M., Mirjat, N. H., Leghari, Z. H., & Saeed, M. S. (2018). Optimal voltage and frequency control of an islanded microgrid using grasshopper optimization algorithm. *Energies*, 11(11), 3191. doi: 10.3390/en11113191
- [13] Karaboga, D., & Basturk, B. (2007). A powerful and efficient algorithm for numerical function optimization: artificial bee colony (ABC) algorithm. *Journal of Global Optimization*, 39(3), 459-471. doi: 10.1007/s10898-007-9149-x
- [14] Kirkpatrick, S., Gelatt, C. D., & Vecchi, M. P. (1983). Optimization by simulated annealing. *Science*, 220(4598), 671-680. doi: 10.1126/science.220.4598.671
- [15] Li, Y., Li, X., Liu, J., & Ruan, X. (2019). An improved bat algorithm based on lévy flights and adjustment factors. *Symmetry*, 11(7), 925. doi: 10.3390/sym11070925
- [16] Liu, J., Liu, L., & Li, Y. (2019). A Differential Evolution Flower Pollination Algorithm with Dynamic Switch Probability. *Chinese Journal of Electronics*, 28(4), 737-747. doi: 10.1049/cje.2019.04.008
- [17] Liu, J., Mao, Y., Liu, X., & Li, Y. (2020). A dynamic adaptive firefly algorithm with globally orientation. *Mathematics and Computers in Simulation*, 174, 76-101. doi: 10.1016/j.matcom.2020.02.020
- [18] Lyu, D., Wang, B., & Zhang, W. (2020). Large-Scale Complex Network Community Detection Combined with Local Search and Genetic Algorithm. *Applied Sciences*, 10(9), 3126. doi: 10.3390/app10093126

- [19] Mafarja, M., Aljarah, I., Heidari, A. A., Hammouri, A. I., Faris, H., Ala'M, A. Z., & Mirjalili, S. (2018). Evolutionary population dynamics and grasshopper optimization approaches for feature selection problems. *Knowledge-Based Systems, 145*, 25-45. doi: 10.1016/j.knosys.2017.12.037
- [20] Mirjalili, S. (2015). Moth-flame optimization algorithm: A novel nature-inspired heuristic paradigm. *Knowledge-Based Systems, 89*, 228-249. doi: 10.1016/j.knosys.2015.07.006
- [21] Mirjalili, S. Z., Mirjalili, S., Saremi, S., Faris, H., & Aljarah, I. (2018). Grasshopper optimization algorithm for multi-objective optimization problems. *Applied Intelligence, 48*(4), 805-820. doi: 10.1007/s10489-017-1019-8
- [22] Mirjalili, S., & Lewis, A. (2016). The whale optimization algorithm. *Advances in Engineering Software, 95*, 51-67. doi: 10.1016/j.advengsoft.2016.01.008
- [23] Mirjalili, S., Mirjalili, S. M., & Lewis, A. (2014). Grey wolf optimizer. *Advances in Engineering Software, 69*, 46-61. doi: 10.1016/j.advengsoft.2013.12.007
- [24] Montano, J., Tobón, A. F., Villegas, J. P., & Durango, M. (2020). Grasshopper optimization algorithm for parameter estimation of photovoltaic modules based on the single diode model. *International Journal of Energy and Environmental Engineering, 1*-9. doi: 10.1007/s40095-020-00342-4
- [25] Pinto, H., Peña, A., Valenzuela, M., & Fernández, A. (2018, April). A binary grasshopper algorithm applied to the knapsack problem. In *Computer Science On-line Conference* (pp. 132-143). Springer, Cham. doi: 10.1007/978-3-319-91189-2_14
- [26] Saremi, S., Mirjalili, S., & Lewis, A. (2017). Grasshopper optimisation algorithm: theory and application. *Advances in Engineering Software, 105*, 30-47. doi: 10.1016/j.advengsoft.2017.01.004
- [27] Tharwat, A., Houssein, E. H., Ahmed, M. M., Hassanien, A. E., & Gabel, T. (2018). MOGOA algorithm for constrained and unconstrained multi-objective optimization problems. *Applied Intelligence, 48*(8), 2268-2283. doi: 10.1007/s10489-017-1074-1
- [28] Yang, X. S. (2009, October). Firefly algorithms for multimodal optimization. In *International Symposium on Stochastic Algorithms* (pp. 169-178). Springer, Berlin, Heidelberg. doi: 10.1007/978-3-642-04944-6_14
- [29] Yang, X. S. (2010). A new metaheuristic bat-inspired algorithm. In *Nature Inspired Cooperative Strategies for Optimization (NICSO 2010)* (pp. 65-74). Springer, Berlin, Heidelberg. doi: 10.1007/978-3-642-12538-6_6
- [30] Yang, X. S., & Deb, S. (2009, December). Cuckoo search via Lévy flights. In *2009 World Congress on Nature & Biologically Inspired Computing (NaBIC)* (pp. 210-214). IEEE. doi: 10.1109/NABIC.2009.5393690

(*Full reference list is available upon request from the corresponding author.)

E-commerce and Fashion Retail Industry: An Empirical Investigation On the Online Retail Sector in the Gulf Cooperation Council (GCC) Countries

(Full Paper)

Prakash Rao, BITS Pilani, Dubai Campus, UAE, p20170001@dubai.bits-pilani.ac.in
Nitin Simha Vihari, BITS Pilani, Dubai Campus, UAE, nitinvihari@dubai.bits-pilani.ac.in
Shazi Shah Jabeen, BITS Pilani, Dubai Campus, UAE, shazi@dubai.bits-pilani.ac.in

ABSTRACT

The aim of this study is to examine the digitalization factors affecting Ecommerce in the fashion retail industry and propose an expanded model for a behavioral intention to use the e-commerce shopping channel that incorporates the Theory of Reasoned Action (TRA) and its extensions of Technology Acceptance Model (TAM) and Theory of Planned Behavior (TPB). A data of 872 respondents was collected, who were fashion retail customers in Gulf Cooperation Council Countries of United Arab Emirates (UAE), The Kingdom of Saudi Arabia (KSA), Oman, Kuwait, Bahrain and Qatar. Structural Equation Modeling using AMOS and Sequential Mediation Analysis using Process Macro were used to validate the proposed conceptual framework. Furthermore, a comprehensive demographic analysis was conducted using ANOVA at the respondent's country level. Findings include age and university education of the consumer did moderate the relationship between the study constructs, whereas gender, income level and work location did not moderate. Trust and perceived utility of e-commerce channels acts as sequential mediators between perceived ease of use, subjective norms and behavioral intention to use respectively. Future studies will need the behavior models to be extended to incorporate the fundamental changes in consumer behavior to the pandemic. This research builds on the existing studies on online shopping intentions by including a comprehensive model incorporating all the constructs affecting online shopping continuance. It is one of the few comprehensive studies in the GCC region which is the stronghold of Brick & Mortar (B&M) shopping.

Keywords: E-commerce, Retail Fashion, GCC, Technology Acceptance Model, Theory of Reasoned Action, Theory of Planned Behavior

*Corresponding author

INTRODUCTION

Ecommerce is the business of selling, buying, logistics, or other transactions via the internet and it relates to technology mediated exchanges between parties (individuals and/or organizations) (Zwass, 1996). The global retail landscape is facing a significant shift in the retail value chain as new retail business models and competitors are emerging, and traditional brick-and-mortar store-based retailers are facing threats from all directions. This is primarily due to the emergence of ecommerce under the rising influence of digitalization and the overall effect is downward pressure on revenues and profits for the brick and mortar retailers. In 2017, the ecommerce industry made a significant impact when it crossed 10% of all global retail sales. (*E-commerce in MENA: Opportunity Beyond the Hype*, 2019). Today, ecommerce market share is \$2.2 trillion, and it is growing at a compounded annual growth rate (CAGR) of 24%, compared to the global retail sector growth as a whole, this is at-least four times faster. Ecommerce is seen now as the key growth engine for global retail, its share has grown from 7% in 2012 to 39% in 2017, and is expected to cross 50% by 2020. In developed economies of the West, ecommerce is growing at a CAGR of 20%. The proportion of ecommerce retail to the Gross Domestic Product (GDP) for Western Europe is in double digits for many countries. The annual fashion sales revenue in the Middle East's Gulf Cooperation Council (GCC) countries of United Arab Emirates (UAE), The Kingdom of Saudi Arabia (KSA), Oman, Kuwait, Bahrain and Qatar total approximately to \$50 billion, reflecting the region's significant market for retail fashion. Approximately one third of the ecommerce spends are in the fashion retail category. It is safe to conclude that the retail industry in the Middle East and North Africa (MENA) inclusive of the GCC is on the verge of a decisive shift (The State of fashion 2020, 2020). Ecommerce is a reality, remapping the customers' path to purchase, reinventing customer experiences, disrupting legacy business models, and fostering new growth opportunities for retailers across all sizes, as well as for an emerging generation of pure play ecommerce companies like Noon and Jumia. The GCC consumers are also becoming increasingly connected, with digitalization solutions and adoption on the uptrend. As shoppers migrate into online, corporations typically follow suit, fostering a gradual and irreversible development of the digital environment in areas such as media and ecommerce (Lin, 2007). Corporations started to see digitalization taking a more crucial role in business strategy post 2010, with media leading from the front. Within the duration of just five years, the portion of digital media shot up from less than 10% in 2012 to more than 30% by 2017. Internet penetration is very high in the UAE and KSA at 99% and 89% respectively, compared to this China is just at 57%. Dubai in

UAE is the GCC region's retail fashion shopping capital, but other GCC markets are growing fast, with KSA taking a place at the top of the table. Dubai is the flagbearer and benchmark for retail fashion and will continue to play the leading role as the GCC's window to the fashion world, supported by modern world-class malls offering a top-end consumer experience. The GCC fashion companies are therefore required to adapt to the changing social reforms, with fashion designers, social platforms, social media stars and influencers, and local style trends starting to feature consistently and significantly more in the global fashion platforms and narratives. The GCC is experiencing a tectonic shift from being a traditional importer of fashion trends to an emerging exporter. In the GCC, the shopping mall with the Brick and Mortar (B&M) stores are a part of the shopping and family entertainment culture but even in the GCC the effects of digitalization are revolutionizing the way the consumers shop (*Retail Disruption - What's the outlook for the ME*, 2017). A spate of new online portals, acquisitions, marketplace explosions into the GCC ecommerce space, improved mobile technology, explosion of digital content and increased confidence in transacting online has contributed to this growth. The top two online spenders in the GCC are consumers in the UAE and the KSA. It's clear that ecommerce is a fast-growing business in UAE and KSA, market supply is dominated by cross-border players and pure-play platforms. According to a report (*E-commerce in MENA: Opportunity Beyond the Hype*, 2019) the market size for ecommerce is expected to reach AED 32 billion and AED 36 billion in UAE and KSA by 2022 with the CAGR in excess of 30%. For fashion categories the penetration for ecommerce is estimated to range between 10 to 13% for UAE and KSA by 2022.

Impact of covid-19

B&M retail sector is currently going into a tailspin because of the coronavirus pandemic and the resulting lockdown worldwide of retail outlets. The sharpest drops in the initial months of lockdown were at fashion retailers, electronics stores, furniture stores and restaurants. Consumers are going to ecommerce retailers for groceries, cleaning products, fashion, cosmetics, home decor, fitness equipment and other products. A long-standing migration of consumers towards ecommerce is accelerating (Kim, 2020). The coronavirus pandemic has changed the way we consume and relate to the world around us. A metamorphosis in consumption trends had been underway even before the health crisis - the pandemic merely sped some of these up. In this aspect, corporations have been inclined to make substantial changes to their business processes. Overnight, operations and processes of many companies had to go virtual. It is uncertain whether and how many consumers will return to traditional means of shopping after the pandemic ends. Some transformations may be long-lasting even after the pandemic situation eases (Shetty *et al.*, 2020). Digitalization is an obvious play and retailers had been turning to online platforms even before COVID-19, the only difference was that it was not a matter of life and death, which could possibly be the case now, given that most people are still staying indoors. Researchers have examined the effects of the pandemic causing a structural change in consumption and accelerating the digital transformation in the marketplace. Retailers may acclimatize to the digital transformation in the marketplace to recover or even use this to grow further after COVID-19 (Kim, 2020). COVID - 19 has disrupted consumer lives from all the fronts. Corporations and global commerce will embrace new processes once the world recovers post COVID - 19. Multiple new developments in retail like Direct to Consumer Model (D2C), Omni-Channel (OC) Fulfillment, etc. would materialize in the retailers of tomorrow. Retailers that identify these shifts proactively will be the winners in the post COVID-19 era. Some scholars have analyzed these multifaceted scenarios in Fast Moving Consumer Goods (FMCG) and retail companies of India, and have enumerated developments in these markets and potential policies companies must implement in order to recover in the post pandemic phase (Shetty *et al.*, 2020). Mobile phones have become a new mask, almost, enabling people to socially connect without the risk of catching the virus, and that has fueled a lot of new consumption habits. In a global consumer insights survey (PWC, 2020), it has been highlighted that the use of mobile payments by Middle Eastern respondents had increased from 25% in 2018 to 45% – a bigger increase than any other region. Unlike the Western world, mobile shopping is a growing trend here in the GCC. It therefore appears certain that digital engagement by Middle East shoppers will become stronger and more widespread, even after the lifting of current social distancing measures.

THEORETICAL BACKGROUND AND CONCEPTUAL FRAMEWORK

The theoretical models to explain behavioral intention to use the ecommerce channel have measures relating to user acceptance, user behavior and adoption of technology. The models also address hedonic and utilitarian motivation. Hedonic Motivation relates to adventure, social norms and gratification needs from channel use, whereas Utilitarian Motivation relates to efficiency of transactions and value from use of the channel. The most commonly used conceptual theories for examining behavioral intention in technological studies were the Technology Acceptance Model (TAM; Davis *et al.*, 1989), Theory of Planned Behavior (TPB; Ajzen;1991) and Theory of Reasoned Action (TRA) by Fishbein and Ajzen in (1975). Rouibah, Lowry, and Hwang (2016) compared the three models TRA, TPB and TAM for e-banking adoption in Malaysia. Amresh (2016) applied a five-factor e-shopping adoption model based on TAM with addition of an additional construct of trust. Kim *et al.* (2009) used the models of TAM and TRA to explore the impact of ease of use, usefulness, and enjoyment, and subjective norm regarding the intention to use mobile channel technology for shopping. By using a composite integrated model of TPB and TAM, these studies examined the associations between attitude, subjective norm, perceived behavior control, Perceived Utility (PU) and Perceived Ease of Use (PEU) towards intention and ecommerce purchasing behavior (Lin, 2007; Yayla & Hu, 2007; Sentosa &

Mat, 2012). Brosdahl and Moudi (2013) used the Extended Ecommerce Technology Acceptance Model and examined what customers from both KSA and the United States (U.S) perceived about using technology for ecommerce shopping as well as their perceptions of the online shopping risk. In the GCC, there are still significant gaps in terms of a comprehensive evaluation of all the variables affecting ecommerce, hence there is a requirement for a comprehensive analysis of the consumer behavior activity on choice of the shopping channel when all the digitalization related variables are taken together. The current behavior models like the TRA and TAM do not cover all the constructs leading to shopping intention in the GCC. Constructs and attributes relating to local laws/regulations, customer experience, Omni channel capability, infrastructure and GCC social norms are not covered in existing studies. In the GCC, the aspects of the shopping culture and use of malls as family entertainment centers needs to be studied. The effect of the demographic diversity on ecommerce adoption must be studied critically. External variables included in PU include the effect of the nascent legal/tax/government regulations framework in this region and its effect on ecommerce.

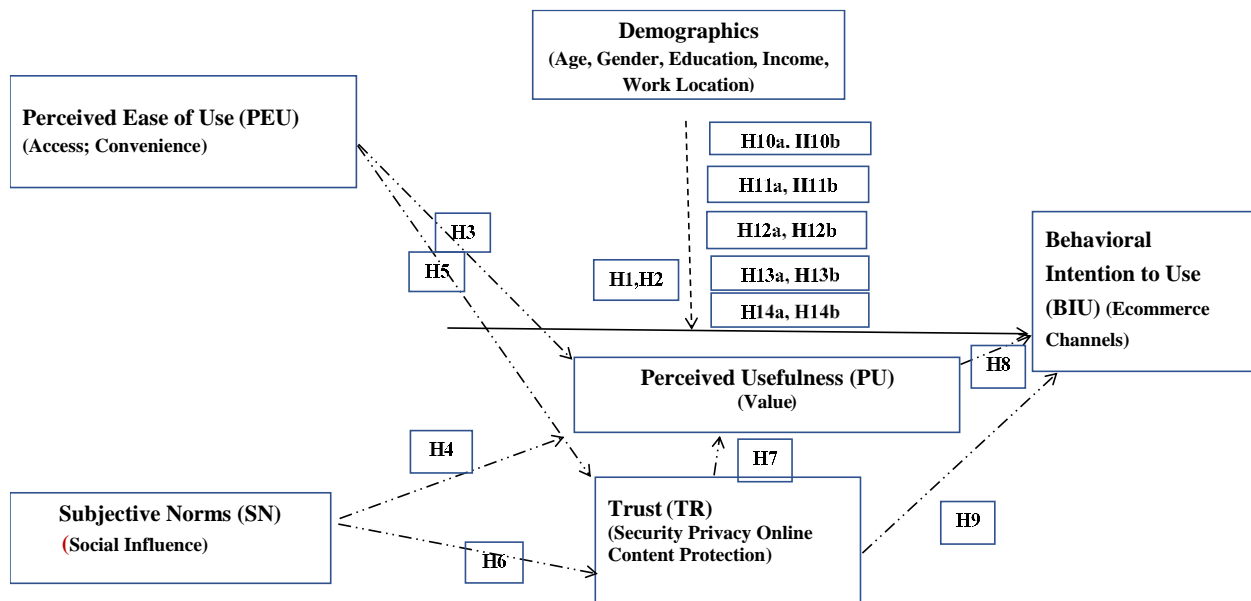

Figure 1: Proposed Hypothesized Framework

RESEARCH METHODOLOGY

The research was conducted for the Fashion Retail Industry (Apparel, Footwear, Accessories) in the Gulf Cooperation Council (GCC) countries. Stratified random sampling and convenience sampling techniques was used to select the participants for the study (Chin 1998; Hair *et al.* 2017). A quantitative technique was applied involving an online survey being administered randomly to 1274 residents of GCC countries. Of those approached, 891 completed the questionnaire and therefore, formed the research sample. Structural Equation Modelling and Sequential Mediation Analysis were used to validate the proposed research framework. Considering the measurement model, the psychometric properties of the construct measures in terms of its internal consistency reliability, convergent validity and discriminant validity was assessed. Furthermore, the study has tested for the moderating effects of the demographic variables such as Gender, Age, Educational level and Monthly Income in the formation of e-commerce behavioral intention to use. A multisampling analysis was performed to create a multi group result of casual relationships, by making the entire dataset into four sub samples each for the four demographic characteristics considered. In order to ensure that all the study constructs were perceived by all the categories of consumer demographics in a similar way, factorial invariance and structural invariance was measured using the Lagrange Multiplier (LM) test (Lee & Strazicich, 2004). The test compares the chi-square improvements values and their p-values of all the casual relationships among the four demographic categories. The presence of factorial invariance is confirmed when study results indicate a non-significant chi-square improvement and vice-versa for the presence of structural invariance. Table 1 shows the basic descriptive measures such as Mean, Standard Deviation and Inter-construct correlations of all the latent constructs given in the model.

Table 1: Descriptive Statistics

Constructs	Mean	SD	PEUEC	SNEC	TREC	PUEC	BIUEC
PEUEC	4.06	0.89	0.88				
SNEC	2.77	1.004	0.26**	0.86			
TREC	3.41	0.85	0.56**	0.45**	0.92		
PUEC	3.56	0.88	0.51**	0.32**	0.59**	0.82	
BIUEC	3.75	0.89	0.58**	0.33**	0.64**	0.62**	0.78

A correlation matrix (shown in table 2) is computed among all the latent constructs and the demographic variables. It is observed that Gender is negatively correlated in call cases, Age is only positively correlated with Perceived Ease of use and Non-GCC retails consumers have negative association with only Perceived Usefulness.

Table 2: Correlation Matrix

Constructs/Demographics	Gender	Age	Education	Income	GCC	Non-GCC
PEUEC	-0.12	0.09	0.21	0.14	0.05	0.12
SNEC	-0.09	-0.11	-0.06	-0.1	0.18	0.19
TREC	-0.06	-0.14	-0.15	-0.32	0.23	0.05
PUEC	-0.14	-0.17	0.17	0.25	-0.11	-0.28
BIUEC	-0.19	-0.08	0.12	-0.22	-0.16	0.16

The presence of common method bias was evaluated via Harman's single-factor test and achieved a single un rotated factor resulted in a less than 50% variance explained. In order to evaluate the significant differences among the retails consumer of GCC on the various predictors of the behavioral intension to use ecommerce channels, the study has looked into their dependence on the demographic variables such as Age, Gender, Education, Monthly Income levels and home country (GCC and Non-GCC). The results in table 3 have revealed that significant difference existed in the way men and women perceived PEUEC (mean men= 4.35 vs. mean woman= 4.08; $F = 2.63$, p -value <0.05), SNEC (mean men= 2.89 vs. mean woman= 2.67; $F = 11.35$, p -value <0.05), TREC (mean men= 3.46 vs. mean woman= 3.37; $F = 2.35$, p -value <0.05), PUEC (mean men= 3.54 vs. mean woman= 3.39; $F = 3.62$, p -value <0.05) and BIUEC (mean men= 3.78 vs. mean woman= 3.43; $F = 2.43$, p -value <0.05). It appears that men perceived significantly better than women with respect to all the constructs.

Furthermore, retail consumers with different age groups rated their intention to e-commerce adoption in different ways such as PEUEC (mean 18-50 years= 3.96 vs. mean > 50 years =3.32; $F = 4.18$, p -value <0.05), SNEC (mean 18-50 years= 2.56 vs. mean > 50 years = 2.71; $F = 3.91$, p -value <0.05), PUEC (mean 18-50 years= 3.68 vs. mean > 50 years = 3.19; $F = 2.63$, p -value <0.05). TREC (mean 18-50 years= 3.52 vs. mean > 50 years =2.40; $F = 2.45$, p -value > 0.05), BIUEC (mean 18-50 years= 3.72 vs. mean > 50 years=3.03; $F = 2.17$, p -value > 0.05). It can be concluded that significant differences can be seen in the way consumers perceived usefulness, perceived ease of use and subjective norms. And, there is no significant differences observed the ways consumer evaluated trust and behavioral Intention to use constructs. All in all, consumers within the age bracket of 18-50 are better motivated to using ecommerce services.

The study has classified the education level of the consumers into two different groups such as university and non-university. Consumers rated the constructs as PEUEC (mean university= 4.05 vs. mean non-university = 3.29; $F = 2.98$, p -value <0.05), SNEC (mean university= 3.10 vs. mean non-university = 2.83; $F = 6.7$, p -value <0.05), TREC (mean university= 3.51 vs. mean non-university = 3.14; $F = 2.2$, p -value <0.05), PUEC (mean university= 3.58 vs. mean non-university = 3.19; $F = 2.9$, p -value <0.05) and BIUEC (mean university= 3.73 vs. mean non-university = 3.22; $F = 3.45$, p -value <0.05). There is a significant difference between the consumers with and without university education and the consumers with university education have better motivation and less doubtful towards consumer ecommerce resources. Next, consumers with diverse income groups ($\leq 20K$ & $>20K$ AED) and work location (GCC & Non GCC) have also been studied. The results show that there is a significant difference between the motivation to consumers based on their income groups and work location. Consumers with more than AED 20K disposable income rated the ecommerce option better than the other channels and

consumers whose work location is in NON-GCC areas have rated high on ecommerce channels when compared to their counterparts in GCC.

Table 3: ANOVA Results

Variable	Categories	N	PEUEC		SNEC		TREC		PUEC		BIUEC	
			Mean	SD	Mean	SD	Mean	SD	Mean	SD	Mean	SD
Gender	Men	541	4.35	0.95	2.89	1.03	3.46	0.88	3.54	0.93	3.78	0.92
	Women	349	4.08	0.84	2.67	0.96	3.37	0.82	3.39	0.83	3.43	0.85
	F-stat	-	2.63*	-	11.35*	-	2.35**	-	3.62*	-	2.43**	-
Age	18-50	794	3.96	1.97	2.56	1.50	3.52	1.73	3.68	1.73	3.72	2.08
	>50	96	3.32	0.92	2.71	0.94	2.40	0.88	3.19	0.89	3.03	0.93
	F-stat	-	4.18*	-	3.91*	-	2.45	-	2.63*	-	2.17	-
Educational Level	University	628	4.05	0.91	3.10	1.07	3.51	0.90	3.58	0.89	3.73	0.96
	Non-University	262	3.29	1.00	2.83	1.05	3.14	0.94	3.19	0.96	3.22	0.88
	F-stat	-	2.98**	-	6.7*	-	2.2*	-	2.9*	-	3.45**	-
Income	<= 20000 AED	594	3.82	0.90	2.28	0.99	3.62	0.84	3.58	0.83	3.75	0.91
	> 20000 AED	296	4.05	0.95	3.24	1.04	3.27	0.88	3.55	0.98	3.83	0.87
	F-stat	-	2.34**	-	11.56*	-	4.36*	-	1.87**	-	3.68*	-
Work Location	GCC	376	4.04	0.73	2.36	0.68	3.23	0.61	3.64	0.66	3.77	0.71
	Non-GCC	514	4.73	0.31	2.56	0.19	3.42	0.29	4.00	0.67	4.33	0.58
	F-stat	-	1.62*	-	2.51*	-	2.42*	-	2.31*	-	1.58*	-

The study used the Lagrange Multiplier (LM) test in order to test the moderating role of the demographic characteristics such as age, gender, income level, education level and work location. The results of the LM test provided the chi-square differences and their corresponding significance values of all the five demographic characteristics such as gender ($\chi^2_{diff} = 2.83$; p -value >0.05), age ($\chi^2_{diff} = 3.68$; p -value <0.05), university education ($\chi^2_{diff} = 2.27$; p -value <0.05), income ($\chi^2_{diff} = 4.35$; p -value >0.05) and Work Location ($\chi^2_{diff} = 4.17$; p -value >0.05). It can be concluded that, age and university education of the consumer did moderate the relationship (H10a, H10b, H12a, H12b) between the study constructs, whereas gender, income level and work location did not moderate. Thus, the hypotheses were not supported (H11a, H11b, H13a, H13b, H14a, H14b). Next, an evaluation of Average Variance Extracted (AVE) was computed using factor loadings to check the convergent validity of the construct measures. It was observed that Composite Reliability is more than 0.7, and the AVE values are more than 0.50, which indicate that convergent validity is observed to be accomplished and the measurement items had a good fit to the respective variables (Fornell and Larcker 1981; Hair *et al.* 2017). Discriminant validity was also inspected by comparing the shared variance between factors with the square root of the AVE values as per Fornell Larcker criteria, which states that square root of AVE of each of these correlations should more than inter-item correlation values in that respective column (Fornell and Larcker 1981). Table 4 confirms that the first was lower than the latter. Thus, discriminant validity was achieved.

Table 4: Discriminant & Convergent Validity

Constructs	AVE	CR	PEUEC	TREC	PUEC	BIUEC	SNEC
PEUEC	0.53	0.92	0.72				
TREC	0.56	0.91	<i>0.56**</i>	0.74			
PUEC	0.65	0.92	<i>0.51**</i>	<i>0.59**</i>	0.81		
BIUEC	0.57	0.82	<i>0.58**</i>	<i>0.64**</i>	<i>0.62**</i>	0.75	
SNEC	0.61	0.86	<i>0.26**</i>	<i>0.45**</i>	<i>0.32**</i>	<i>0.33**</i>	0.78

Note: Bold values are AVE square root values and Italicized are total inter-item correlation values. * $p < 0.05$, ** $p < 0.01$

The study used a two stage approach of Structural Equation Modeling (SEM) using Amos 20 to validate the proposed research framework.

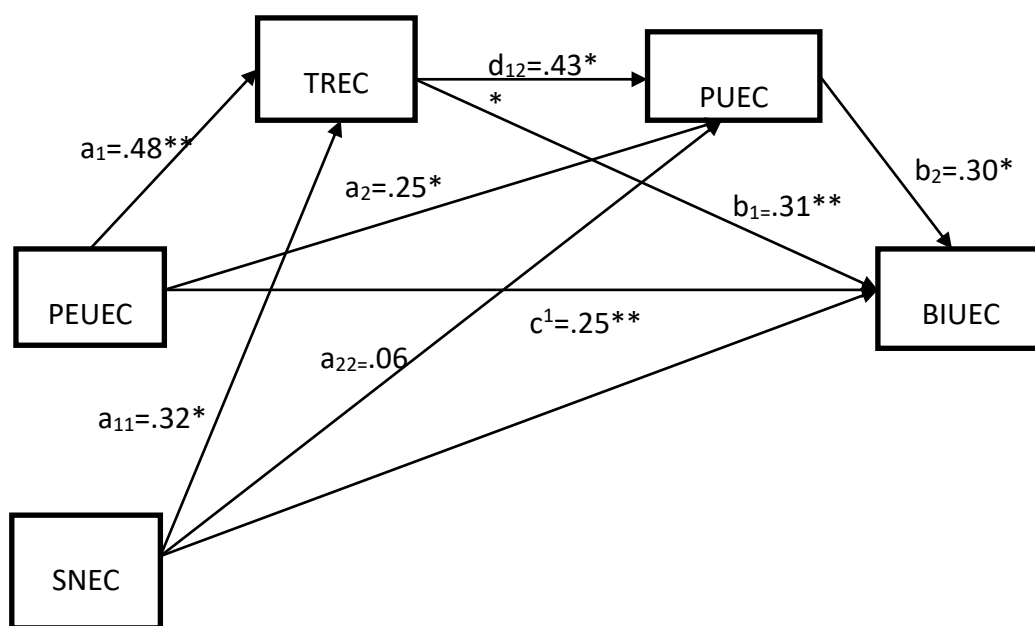

Fig 2: Structural Model

Confirmatory Factor Analysis (CFA) was carried out with all the latent constructs and the results revealed that the non-centrality value (χ^2/df) is 4.3 is significant at $p < 0.01$ and the other fit indexes such as NFI (0.92), SRMR (0.07), GFI (0.93), AGFI (0.91) have exceeded the recommended limits, thereby indicating good model fit (Hair et al, 2010). Furthermore, the results of the structural model also showed an acceptable fit to the data (Chi-square = 589.3, $df = 125$, $p < 0.01$; $NC = 4.7$; CFI = 0.91; NFI = 0.88; SRMR = 0.07; AGFI = 0.93). The values of the fit indices show an adequate fit of the structural model with the data and all the parameters are within acceptable limits (Hair et al., 2010).

The study has conducted sequential mediation analysis twice to predict the Behavioral Intention to Use the e-commerce channels with PEUEC, TREC, PUEC as one set of predictors (table no 5) and SNEC, TREC and PUEC as the second set (table no). Model 6 of Hayes Process macro was used to perform the analysis (Hayes, 2013). The overall regression model predicting Behavioral Intention to Use the e-commerce channels from PEUEC, TREC and PUEC was found to be significant with $F(887) = 355.95$, $p < 0.01$ and 54% of variance explained (see table). The indirect path from PEUEC to BIUEC through TREC ($\beta = 0.15$, $SE = .07$, $LLCI = -0.083$, $ULCI = 0.324$) and PUEC ($\beta = 0.08$, $SE = .04$, $LLCI = -0.065$, $ULCI = 0.318$) was found to be significant. The direct relationship between TREC and BIUEC ($b_1 = .31$, $SE = .05$, $LLCI = 0.357$, $ULCI = 0.726$, $p < 0.01$) and between PUEC and BIUEC ($b_2 = .30$, $SE = .04$, $LLCI = 0.313$, $ULCI = 0.429$, $p < 0.01$) were found to be significant. The confidence intervals of the indirect paths from PEUEC to BIUEC through PUEC (coefficient = 0.08, $SE = 0.04$, $LLCI = 0.412$, $ULCI = 0.728$) and from PEUEC to BIUEC through both TREC and PUEC (indirect effect coefficient = 0.03, $SE = 0.02$, $LLCI = 0.361$, $ULCI = 0.527$) did not contain zero. The total effect of PEUEC on BIUEC was found to be statistically significant ($c = .46$, $SE = .06$, $LLCI = 0.622$, $ULCI = 0.915$, $p < 0.01$), after controlling for TREC and SNEC, this relationship has reduced but remained significant ($c^1 = .25$, $SE = .04$, $LLCI = 0.269$, $ULCI = 0.403$, $p < 0.01$), indicating partial mediation.

Table 5: Results of Mediation Analysis (a)

Antecedent	Consequent								
	TREC			PUEC			BIUEC		
	Coeff.	SE	<i>p</i>	Coeff.	SE	<i>p</i>	Coeff.	SE	<i>p</i>
PEUEC	0.48	0.02	<0.01	0.25	0.03	<0.05	0.25	0.02	<0.05
TREC	-	-	-	0.43	0.03	<0.01	0.31	0.32	<0.01
PUEC	-	-	-	-	-	-	0.30	0.02	<0.01
	R2= 0.32			R2= 0.39			R2= 0.54		
	F(889)= 419.56, p<0.001			F(888)= 295.09, p<0.001			F(887)= 355.95, p<0.001		

The overall regression model predicting Behavioral Intention to Use the e-commerce channels from SNEC, TREC and PUEC was found to be significant with $F(887) = 303.3$, p -value < 0.01 and 51% of variance explained (see table 6). The indirect path from SNEC to BIUEC through TREC ($\beta = 0.11$, $SE = .07$, $LLCI - 0.078$, $ULCI - 0.147$) and PUEC ($\beta = 0.02$, $SE = .04$, $LLCI - 0.259$, $ULCI - 0.415$) was found to be significant. The direct relationship between TREC and BIUEC ($b_1 = .31$, $SE = .05$, $LLCI - 0.357$, $ULCI - 0.726$, $p < 0.01$) and between PUEC and BIUEC ($b_2 = .30$, $SE = .04$, $LLCI - 0.313$, $ULCI - 0.429$, $p < 0.01$) were found to be significant. The confidence intervals of the indirect paths from SNEC to BIUEC through PUEC (coefficient = 0.02, $SE = 0.04$, $LLCI - 0.307$, $ULCI - 0.547$) and from SNEC to BIUEC through both TREC and PUEC (coefficient = 0.04, $SE = 0.03$, $LLCI - 0.581$, $ULCI - 0.963$) did not contain zero. The total effect of SNEC on BIUEC was found to be statistically significant ($c = .42$, $SE = .08$, $LLCI - 0.072$, $ULCI - 0.327$, $p < 0.01$), after controlling for TREC and SNEC, this relationship has reduced but remained significant ($c^{11} = .02$, $SE = .16$, $LLCI - 0.762$, $ULCI - 1.205$, $p < 0.05$), indicating partial mediation.

Table 6: Results of Mediation Analysis (b)

Antecedent	Consequent								
	TREC			PUEC			BIUEC		
	Coeff.	SE	<i>p</i>	Coeff.	SE	<i>p</i>	Coeff.	SE	<i>p</i>
SNEC	0.32	0.02	<0.001	0.06	0.02	<0.05	0.02	0.02	<0.001
TREC	-	-	-	0.43	0.03	<0.001	0.31	0.32	<0.001
PUEC	-	-	-	-	-	-	0.30	0.03	<0.001
	R2= 0.21			R2= 0.36			R2= 0.51		
	F(889)= 228.11, p<0.001			F(888)= 248.52, p<0.001			F(887)= 303.3, p<0.01		

CONCLUSION AND IMPLICATIONS

This paper offers a framework to understand and predict consumer behavior using ecommerce in the context of shopping for fashion goods. In addition, the present study contributes to academia by applying TAM, TPB and TRA to the technologically advanced retailing channel. This study provides an understanding of the consumer's attitude and behavioral intention to use the ecommerce channel for fashion retail industry. Our findings also suggest that the proposed research model was a very useful framework to test the effects of consumers' perceptions, attitudes and intention for using the ecommerce channel for shopping in the fashion retail industry. Results of the data analysis finds that perceived ease of use and subjective norm of e-commerce positively influence customer's behavioral intention to use (H1 and H2 supported). Perceived ease of use is also positively

influence perceived usefulness and trust towards e-commerce (H3 and H5 supported). Subjective norms of e-commerce positively influence perceived usefulness and trust towards e-commerce (H4 and H6 supported). Trust factor has a positive influence on perceived usefulness of e-commerce (H7 supported); both of them acts as sequential mediators between perceived ease of use – behavioral intention to use and subjective norms - behavioral intention to use (H8 and H9 supported). The outcomes of this study have both practical and theoretical implications. The most important contribution of this study is to illustrate the adoption process of the ecommerce channel through the PEU, SN constructs mediating through TR and PU by extending the TRA /TAM models. From a practical viewpoint, fashion retailers should enhance the construct related to ease of use aspects of technology related to access and convenience. Another focus area is the construct related to trust associated with safety and security related to using the ecommerce channel. Focusing on ease of use and trust will enhance the usefulness of using this channel leading to the BIU the channel. Thus, it is important for fashion retailers to build favorable consumer attitudes toward ecommerce, which furthermore influence their positive ecommerce behaviors. Future research may consider examining other industry verticals apart from fashion retail and also examine sustainability as one of the independent variables in the conceptual model. The COVID-19 pandemic is an external variable that has the potential to trigger a massive growth for the ecommerce channel and platforms. Future studies will need to incorporate this external variable in the conceptual model and study the effects thereof on the BIU the ecommerce channel. The complex emerging picture of the post-lockdown balance between B&M and ecommerce shopping in the Middle East, in a retail setting where COVID-19 is a continuing threat and social distancing measures remain in force can be incorporated as external variables in this model. Middle East retailers must respond to COVID-19's impact on consumer behavior by pursuing their customers both online and offline. Post-pandemic, consumer-facing businesses should keep a close watch on several trends that have accelerated since the pandemic has reached this region and can use this paper to advance the findings. Above all, the key watchwords for Middle East retailers following the pandemic will be agility and resilience. Coming out of lockdown, businesses that successfully pursue consumers who are increasingly at ease with online shopping will emerge as winners in a challenging market where customer loyalty cannot be taken for granted.

REFERENCES

- [1] Ajzen, I. (1991). The theory of planned behavior. *Organizational behavior and human decision processes*, 50(2), 179-211.
- [2] Amed I., Balchandani A., Berg A., Hedrich S., Poojara S., Rölkens F. (2020). The State of fashion 2020. McKinsey. <https://www.mckinsey.com/industries/retail/our-insights/the-state-of-fashion-2020-navigating-uncertainty> (Accessed on 11 March 2020).
- [3] Kumar, A., Sikdar, P., & Alam, M. M. (2016). E-retail adoption in emerging markets: Applicability of an integrated trust and technology acceptance model. *International Journal of E-Business Research (IJEER)*, 12(3), 44-67.
- [4] Brosdahl, D., Almousa, M. (2013). Risk perception and internet shopping: comparing United States and Saudi Arabian consumers. *Journal of Management and Marketing Research*. 13(1).
- [5] Charbel S., Tanmay D., Josette G., Cyrille F., Anne-Laure M. (2019). E-commerce in MENA: Opportunity Beyond the Hype. Bain and Company. <https://www.bain.com/insights/ecommerce-in-MENA-opportunity-beyond-the-hype/>. Accessed on 10 January 2020.
- [6] Chin, W. (1998). The partial least squares approach for structural equation modeling. In G.A. Marcoulides (Ed.), *Methodology for business and management. Modern methods for business research* (p. 295–336). Lawrence Erlbaum Associates Publishers.
- [7] Davis, F.D. (1989). Perceived usefulness, perceived ease of use and user acceptance of information technology. *MIS Quarterly*. 13(3), 319-40.
- [8] Fishbein, M., Ajzen, I. (1975). *Belief, Attitude, Intention, and Behavior: An Introduction to Theory and Research*. Addison-Wesley, Reading, MA.
- [9] Fornell, C., Larcker, D. F. (1981). Evaluating structural equation models with unobservable variables and measurement error. *Journal of Marketing Research*, 18(1), 39–50.
- [10] Hair, J., Hollingsworth, C. L., Randolph, A. B., & Chong, A. Y. L. (2017). An updated and expanded assessment of PLS-SEM in information systems research. *Industrial Management & Data Systems*, 117(3), 442-458.
- [11] Hair, J. F., Ringle, C. M., & Sarstedt, M. (2011). PLS-SEM: Indeed a silver bullet. *Journal of Marketing theory and Practice*, 19(2), 139-152. https://www.researchgate.net/publication/283715295_Risk_perception_and_internet_shopping_comparing_United_States_and_Saudi_Arabian_consumers. Accessed on 1 Jan 2020.
- [12] Sentosa, I., & Mat, N. K. N. (2012). Examining a theory of planned behavior (TPB) and technology acceptance model (TAM) in internet purchasing using structural equation modeling. *Researchers World*, 3(2 Part 2), 62.
- [13] Kim, J., Ma, Y. J., & Park, J. (2009). Are US consumers ready to adopt mobile technology for fashion goods? *Journal of Fashion Marketing and Management: An International Journal*, 13(2), 215–230.

- [14] Kim, R. Y. (2020). The Impact of COVID-19 on Consumers: Preparing for digital sales. *IEEE Engineering Management Review*, 48(3), 212-218. <https://ieeexplore.ieee.org/abstract/document/9076>. Accessed on 1 May 2020.
- [15] Lin, H. F. (2007). Predicting consumer intentions to shop online: An empirical test of competing theories. *Electronic Commerce Research and Applications*, 6(4), 433-442.
- [16] PWC (2020). How resilient Middle East consumers have responded to COVID-19. Retrieved from <https://www.pwc.com/m1/en/publications/how-resilient-middle-east-consumers-have-responded-covid-19.html> (December 1, 2020).
- [17] Rouibah, K., Lowry, P. B., & Hwang, Y. (2016). The effects of perceived enjoyment and perceived risks on trust formation and intentions to use online payment systems: New perspectives from an Arab country. *Electronic Commerce Research and Applications*, 19, 33-43.
- [18] Shetty, G., Nougaraheya, S., Mandloi, D., Sarsodia, T. (2020). COVID-19 and global commerce: An analysis of FMCG, and retail industries of tomorrow. SSRN Electronic Journal. <https://ssrn.com/abstract=3603028>. Accessed on 15 May 2020.
- [19] Taki N., Nader K., Vincent G., Rand S. (2017). Retail disruption - What's the outlook for the ME. PWC. 2017. <https://www.pwc.com/m1/en/publications/total-retail-2017/total-retail-middle-east-2017.pdf>. Accessed on 19 January 2020.
- [20] Yayla, A. & Hu, Q. (2007). User acceptance of e-commerce technology: a meta-analytic comparison of competing models. *ECIS 2007 Proceedings*. 5. <http://aisel.aisnet.org/ecis2007/5> (Accessed on December 1, 2020)
- [21] Zwass V. (1996). Electronic Commerce: Structures and Issues. *International Journal of Electronic Commerce*. 1(1): 3-23.

Experiential Learning through Role-Playing in the Digital Technology for Business Course

(Full Paper)

Mathupayas Thongmak*, Thammasat Business School, Thammasat University, Thailand,
mathupayas@tbs.tu.ac.th

ABSTRACT

The purpose of this paper is to investigate the use of role-playing in an introductory course. A study of how new pedagogical approaches affect students' learning is crucial due to the change of learning environments, the more disengaged students, and enrollment declines. A survey of 103 undergraduate students from two classes of the Digital Technology for Business course, who joined the role-playing activities in 2018 and 2019, were collected. The role-playing activities were conducted six rounds for each class, yielding 458 records for data analysis. Results from the nonparametric test equivalent to the dependent t-test indicate that experiential learning through role-playing activities improves students' perceived usefulness (understanding, problem-solving skills, creativity, and topic interests) and their engagement intention (role-playing engagement intention, class attendance intention, and class participation intention) in all aspects. The content analysis of the open-ended question also reveals key comments from students in terms of the received emotions/ feelings, benefits for audiences, general expectations, and expectations about role-playing. Lecturers could apply role-playing to enhance their classrooms and engage more students. The role-playing activities are fewer applied to technology-related courses. This work shows the effectiveness of role-playing and offers the guideline to implement role-playing in courses.

Keywords: Role-playing, IS education, experiential learning, active learning.

*Corresponding author

INTRODUCTION

There are growing concerns in the graduate and enrollment declines of students in Computer and Information Science/ Systems (CIS), including Computer Science (CS), Information Technology (IT), and Management Information Systems (MIS). The CIS communities are thus focused their efforts on response to those problems in various ways (Akbulut-Bailey, 2019; Becerra-Fernandez, Elam, & Clemmons, 2010; Buhl & Lehnert, 2012; Marshall, Cardon, & Godin, 2014; Rouibah, 2012). One of the common approaches to attract students is redesigning curricula (Frost & Pels, 2010; Marshall *et al.*, 2014). An introductory course, which is innovated and interesting, is also used as a recruiting strategy to get more students (Frost & Pels, 2010; Marshall *et al.*, 2014). To make an introductory course achieve the recruitment goal, the course has to engage, interest students, and make them enjoy learning, using the pedagogical design (Frost & Pels, 2010; Rouibah, 2012). Moreover, students are more demotivated and less engaged in their class nowadays (Alabbasi, 2017). In terms of MIS, helping students understand the integration of information systems into a business is another primary concern (Kerr, Troth, & Pickering, 2003). Redesigning curricula and learning experiences to increase participative, experiential, and learners-centered help to develop students' competencies (de Villiers & Botes, 2014). Self-directed learning, incorporating new technologies and tools, is also suggested to transform the MIS courses (Kenny, Lyons, & Lynn, 2017).

The Millennials have been found to enjoy teamwork and collaboration in learning (Alabbasi, 2017). Promoting students' cooperative and teamwork, encouraging active learning, and providing students opportunities to learn in different ways are part of learning-centered classes (de Villiers & Botes, 2014). Active learning has become increasingly acknowledged to enhance higher education students' involvement, motivation, and responsibility (Westrup & Planander, 2013). Higher education has adapted non-traditional methods, practical approaches, and pedagogical tools to provide experiential learning (Karia, Bathula, & Abbott, 2015; Saptono, 2010). Experiential learning approaches have become more popular in business education (Barnabè, 2016; Piercy, 2013). It takes experiences as a basis for learning and gives the importance of students' being active in their learning (Alkan, 2016; Yan & Cheung, 2012). In experiential learning, a teacher's role has changed to the role of coach and students have considerable responsibility for their learning (Alkan, 2016; de Villiers & Botes, 2014). Role-playing is an activity simulating the behavior of a person who has a particular role in a specific situation (Sulaiman *et al.*, 2017). It is one of the learning methods/ practical approaches in experiential learning and active learning (Alkan, 2016; Baglione, 2006; Barnabè, 2016; Crow & Nelson, 2015; Karia *et al.*, 2015; Saptono, 2010; Yan & Cheung, 2012). It is appropriate for both graduate and undergraduate classes and both introductory and advanced classes (Baglione, 2006). It makes learning unstructured and informal, creating a pleasant experience for students (Adams & Mabusela, 2013). It is supported to be a frequently used active learning instructional strategy and a successful tool used in education (Crow & Nelson, 2015; Ponsa, Vilanova, & Amante, 2010; Svensson & Regnell, 2017).

Although role-playing has been applied in various disciplines, it is under-utilized in the classroom (Regnell, 2017)(Alkan, 2016; Baglione, 2006). Besides, there are limited reports of the experiences of using experiential approaches and role-playing in business education and there is little research empirically evaluating its effectiveness (de Villiers & Botes, 2014; Piercy, 2013; Svensson & Regnell, 2017). There is a potential for experiential learning in other business subjects such as MIS to increase the overall quality of business degree programs as well (Karia *et al.*, 2015). Therefore, the purpose of this study is to evaluate the perceived usefulness and engagement intention of an introductory MIS course: digital technology for business taught in an undergraduate business program at a university in Thailand. This work addresses the following research questions: 1. Do the perceived usefulness of role-playing and students' engagement intention increase after being exposed to peer-led role-playing? 2. What are the opinions of students (as audiences) towards the role-playing activities in the class?

LITERATURE REVIEW

Kerr *et al.* (2003) applied a role-playing approach to present information systems cases with 32 university freshmen. Results revealed that students considered the role-play approach superior to the traditional case-study discussions. Saptono (2010) conducted a classroom action research using role-playing in accounting education study program. Findings showed the increase in students' enjoyment level and test scores in the role-playing class, compared to the control class. Adams and Mabusela (2013) explored how role-playing could be adapted in university settings to let students practice and apply knowledge about Learners with Special Educational Needs (LSEN). Findings presented both advantages and disadvantages of role-playing activity such as pleasant and the value of using it. Westrup and Planander (2013) discussed how and why role-playing facilitate students in understanding complex leadership situations. Findings indicated that role-playing supported students by portraying them to understand a human resource management issue from diverse perspectives, generating a collective understanding of a situation. Crow and Nelson (2015) utilized a mixed-method to examine the use of role-playing in an undergraduate course to prepare students to be public school coaches and physical education teachers. Results pointed out that students exhibited skill in the solutions, gained more confidence after participating in the role-playing, and overwhelmingly preferred role-playing over traditional lecture methods. Shen, Nicholson, and Nicholason (2015) employed a group role-playing exercise to engage students in the Enterprise Resource Planning (ERP) course. Findings supported students' positive perceptions of the group role-playing exercise and the improvement of students' knowledge of key business processes and ERP system's roles. Sulaiman *et al.* (2017) explored the effectiveness of role-playing in teaching Arabic. Findings revealed that, in students' opinions, their speaking ability and confidence were enhanced by role-playing. Svensson and Regnell (2017) applied role-playing to requirement engineering education. Results showed a significant difference in students' performance (grade) between those getting higher and lower role-playing project scores. Fominykh, Leong, and Cartwright (2018) investigated experiential learning and role-playing employed in an immersive virtual environment for a professional counseling distance course. Results emphasized the value of experiential learning and role-playing as a potential teaching method for a distance course from the participants' view.

RESEARCH HYPOTHESES

Perceived Usefulness

Understanding

Experiential learning is found to deeply enhance students' comprehension of knowledge (Alkan, 2016). Experiential learning as a classroom activity leads to a better understanding of the subject content (Adams & Mabusela, 2013). Students report that experiential learning boosts the understanding of the subject area and offers an intensive to learn more than traditional lectures (Piercy, 2013). Role-playing provides various advantages for learners and educators (Adams & Mabusela, 2013). It is reported to be positive for students' learning (Shen *et al.*, 2015; Westrup & Planander, 2013). A case study role-playing technique is recommended to be used to facilitate learning and improve understanding in real environments (Baglione, 2006). Role-playing could improve students' understanding of abstract concepts (Svensson & Regnell, 2017). It could help students to comprehend the information systems use in business and enhance their learning and understanding of the course (Kerr *et al.*, 2003). The implementation of role-playing in an accounting class significantly increases students' test scores, compared to the control class (Saptono, 2010). Role-playing enables more reflective views and a chance to foster deep understanding (Westrup & Planander, 2013). Most of the participants in the study of Adams and Mabusela (2013) indicate that role-playing activity yields a better understanding of the course content and more comprehending on how to deal with LSEN. A group role-playing exercise is an effective method to help students understand cross-functional business processes and ERP system's role in cross-functional business processes (Shen *et al.*, 2015).

Problem-Solving Skill

Experiential learning supports students to deeply analyze complex situations. It is an effective model to improve student-teachers scientific process skills (Alkan, 2016). Past studies also indicate that role-playing could broaden students' set of skills for future development such as skills in conflict resolution, decision-making skills (Adams & Mabusela, 2013; de Villiers & Botes, 2014; Svensson & Regnell, 2017; Westrup & Planander, 2013). Role-playing prepares students to create a deeper understanding, which could be applied to current or future decision-making (Fominykh *et al.*, 2018). Role-playing is a

methodological tool to lead students to an appreciation of issues and problems relating to engineering requirements in a real framework (Ponsa *et al.*, 2010). Students are more engaged in critical thinking during role-playing than lectures (Crow & Nelson, 2015). In role-playing, students are not passive observers, so they make decisions, solve problems, and react to the decision results actively (Crow & Nelson, 2015). Role-playing could make students realize the importance of understanding a problem from diverse perspectives. The involvement of students in role-playing exercise increases their thoughtfulness and ability to understand various interpretations and solutions to the problem (Westrup & Planander, 2013). Role-playing could help students develop and practice skills necessary for coping stressful, unfamiliar, complex, or controversial situations (Baglione, 2006).

Creativity

Experiential learning offers the greatest degree of creativity in the classroom (Lazar, 2014). It enhances the linkage of knowledge and creativity at a high level (Alkan, 2016). Role-playing significantly improves students' creativity in handling a crisis (Baglione, 2006). Role-playing is a successful tool to train creativity for undergraduate students (Crow & Nelson, 2015). The acting of role-playing could stimulate students' creativity (Westrup & Planander, 2013). Students could be forced to be creative by case role-playing (Baglione, 2006).

Topic Interests

Innovative pedagogical techniques have a strong association with student interests (Frost & Pels, 2010). Role-playing offers several advantages for both learners and educators including the increase of interest in the subject matter (Svensson & Regnell, 2017). Role-playing is one of the non-traditional methods that can gain more students' interest (Saptono, 2010). Students, both participants and observers, specify that role-playing makes the exercise more real and meaningful for them so making them think more about the issues. This advantage is also stronger for participants (Kerr *et al.*, 2003). Role-playing stimulates students' future interest in the subject (Westrup & Planander, 2013). The group role-playing exercise encourages students' interest to learn more about cross-functional business processes and the roles of an ERP system to support cross-functional business processes (Shen *et al.*, 2015).

Considering the above reasoning, the following hypotheses are proposed:

H1: There is a significant difference between the ratings of role-playing observers' perceived usefulness (a) understanding, b) problem-solving skills, c) creativity, and d) topic interests) before and after joining the role-playing activity in the classroom by peers.

Engagement Intention

Role-Playing Engagement Intention

The experiential learning approach provides active involvement for students in their learning process. The challenge of actually doing an activity significantly increases their motivation (Piercy, 2013). Role-playing is experience-based learning, which engages an individual to the intellect, feels, and sense. Students' acceptance of drama, appreciation of industry roles, empathy through drama, motivational/ enriching virtues of drama for students personally are benefits reflected by students experiencing educational drama (de Villiers & Botes, 2014). Role-playing provides a high degree of student involvement. The use of active learning techniques improves the chance of matching students with different learning styles. All students are normally actively participated in a role-play (Westrup & Planander, 2013). In a role-playing activity, students do not want to take a break to have more time for negotiation. Several past studies indicate that students enjoy role-playing and believe that teachers should use them in their learning (Svensson & Regnell, 2017). Students have a positive attitude towards the active participation required by role-playing (Westrup & Planander, 2013). Compared to traditional methods of teaching, students express more interest in role-playing (Crow & Nelson, 2015). Students want to be participants than observers in role-playing and comment that more research for each business case is needed before the exercise starts (Kerr *et al.*, 2003).

Class Attendance Intention

The experiential learning exercise provides an incentive to learn the subject area better than traditional lectures. Findings support that experience-based or experiential learning is superior to passive modes of learning, emphasizing the inclusion of workshop exercise in business education. In students' viewpoints, experiential learning in the business context enables their satisfaction, the value of business understanding, the value of diversity, learning performance, learning incentive, and group working (Piercy, 2013). Students think that role-playing enables them to become more involved in the case (Kerr *et al.*, 2003). Role-playing promotes better student-teacher interactions. Improving a better student-teacher relation lets exchanging ideas come naturally in a more relaxed environment for students (Svensson & Regnell, 2017).

Class Participation Intention

Experiential learning activities in the classroom could increase involvement (Adams & Mabusela, 2013). Experiential learning is a teaching strategy that ensures active participation and enhances more conceptual learning, compared to other passive techniques (Alkan, 2016). Experiential learning approaches allow students to participate in an activity or event. Such approaches help students to connect theoretical knowledge and their own experiences in a range of subjects. Students indicate

that exercise is a positive experience. It is a valuable opportunity for them to work as a group with students from different backgrounds (Piercy, 2013). Role-playing is an appropriate strategy to facilitate pre-service teachers' active participation in learning. The majority of students feel more engaged but do not volunteer to role-play in front of the class during role-playing, compared to traditional lecture styles (Crow & Nelson, 2015). Role-playing raises students' motivation and effort although the heavy workload is associated (Svensson & Regnell, 2017). It also stimulates students to take a more active role in activities, listen more actively, and pay more attention to the stage (Westrup & Planander, 2013).

Hence, the following hypotheses are developed:

H2: There is a significant difference between the ratings of role-playing observers' engagement intention (a) role-playing engagement intention, b) class-attendance intention, and c) class participation intention) before and after joining the role-playing activity in the classroom by peers.

RESEARCH METHOD

Active learning and student-centered pedagogy were strongly supported by the university. Data was collected from a purposive sample of undergraduate students undertaking the Digital Technology for Business course, an introductory MIS course, who took part in this study during the 2018–2019 academic years. Steps in the role-playing assignment were adapted from generic steps in the study of Shen *et al.* (2015), Lazar (2014) and Crow and Nelson (2015). First, the preparation phase, an instructor introduced the role-playing concept and examples and explained the details of the student-led role-playing assignment specified in the course syllabus. Then, all students were divided into six groups voluntarily. Each group was assigned to lead a role-play related to each course topic differently. Students were free to design their role-playing activities for audiences (students in other groups as observers) because role-playing could be simple or complex, spontaneous or planned, using a fictional or real-life scenario (Lazar, 2014; Svensson & Regnell, 2017; Westrup & Planander, 2013). All students were designed to involve as both role-players and audiences because the study of Kerr *et al.* (2003) emphasized that observers of role-playing were not enthusiastic as much as participants and the study of Kerr *et al.* (2003) specified that all students should participate in role-playing exercises. An instructor taught each topic according to the course outline. Second, the enactment phase, each group conducted role-playing after a teacher taught that topic. Role-playing was suggested by Adams and Mabusela (2013) to be used as a complement of traditional teaching formats not to replace them. The duration for each role-playing was around 35-40 minutes. Five minutes for audiences to answer quick questions in Kahoot. An instructor was a facilitator in this phase, conforming to the suggestions of Svensson and Regnell (2017) and Alkan (2016). Last, the reflection phase, an instructor would let observers evaluate the performance of their peers and give feedback through an online questionnaire, taking around 5 minutes to complete. According to Crow and Nelson (2015), students were more likely to become and remain engaged in role-playing if they were directly assigned to observe and critique others rather than just watching it.

The experimental one-group retrospective pre-post research design was applied. The retrospective pre-post method was the assessment of learners' self-reported changes in their perceptions such as attitudes or behaviors. Both before and after information was gathered at the same time to minimize pretest sensitivity and the response shift bias (over or underestimation of their perception changes) (Sánchez-Mendiola, Morales-Castillo, Torruco-García, & Varela-Ruiz, 2015). One questionnaire was given to the students after each role-playing activity in the reflection phase for each subject topic. It included multiple-choice questions using a six-point Likert scale to solicit feedback from students (observers), for instance, after watching role-playing, what is your level of understanding of this topic (1-lowest, 6-highest)? There were 14 questions for pre- and post-tests for perceived usefulness (understanding, problem-solving skills, creativity, and topic interests) and engagement intention (role-playing engagement, class attendance intention, and class participation intention). One open-ended question was added at the end of each questionnaire to ask for comments, feedback, and additional suggestions for role-players to improve the overall satisfaction of audiences. All responses did not negatively affect students' scores, so they were free to show their true opinions. Demographics were not a part of the subject of investigation, so they were not collected. This study is a sub-project of the EXPERIENTIAL LEARNING project.

DATA ANALYSES

There were 103 undergraduate students from two sections of the Digital Technology for Business course, who participated in the role-playing activities in 2018 and 2019. Seventy-eight students were females, whereas twenty-five of them were males. Most of them were freshmen, only some of them (17 students) were sophomores. The six rounds of role-playing activities for each class generated 458 self-reported records for data analysis. Most groups normally reviewed the course content using PowerPoint presentations and/ or video clips together with role-playing. Students role-played course topics to represent not only persons, for instance, people in a traditional company vs. people in a company using IS/ IT, people in a manufacturing company who sold fruits, people in a company who sold notebook, and people who facing computer crime issues, but also things e.g. data elements in database and nodes in different network types. For some groups, they let observers join their role-playing activities or additional games introduced by the presented group. The paired-samples t-test was planned to be conducted to examine changes in their perceived usefulness and engagement intention from the close-ended questions. However, because the pre- and post-test scores of observers were not normally distributed, the nonparametric test equivalent to the dependent t-test (the Wilcoxon signed-rank test) was applied instead. Data from an open-ended question in the survey were processed using content analysis.

RESULTS AND DISCUSSION



Figure 1. The holistic view of students' comments

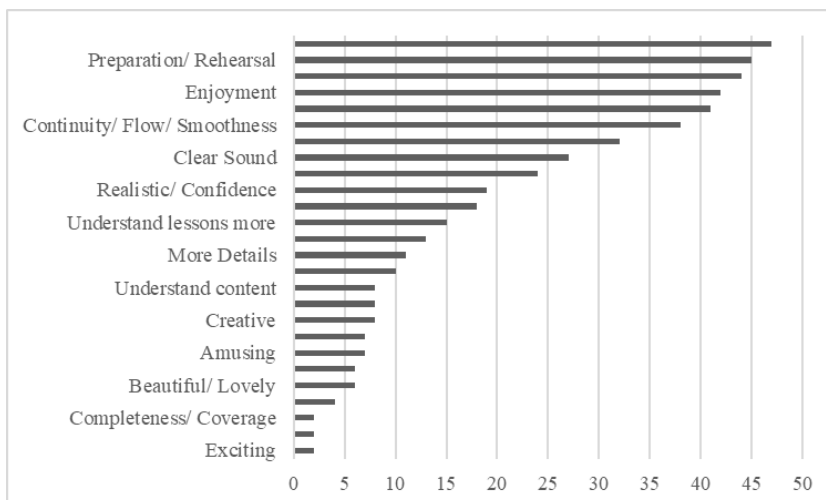

Figure 2. Key findings for role-playing show sorted by the number of occurrences

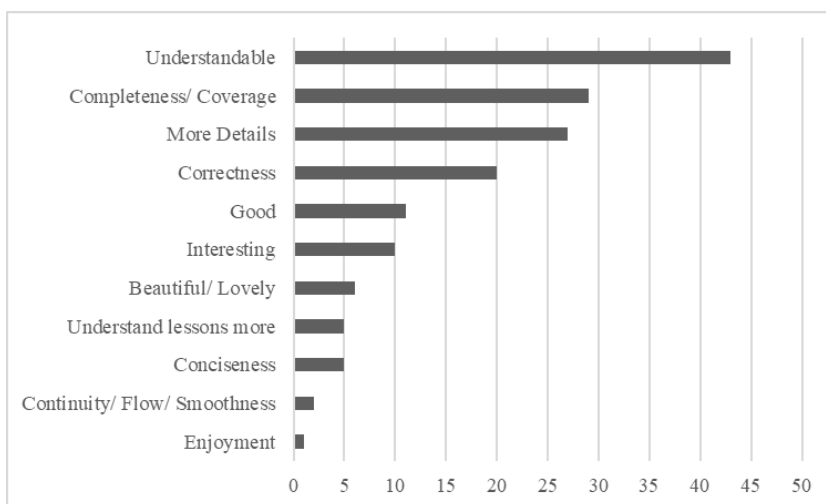

Figure 3. Key findings for content and slides sorted by the number of occurrences

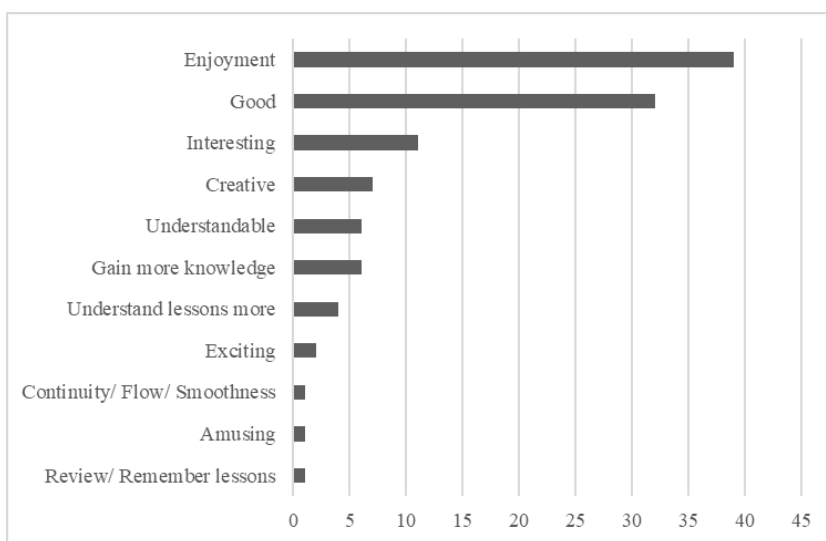

Figure 4. Key findings for overview of students' presentation sorted by the number of occurrences

Hypothesis Testing

A Wilcoxon Signed-Ranks Test indicated that post-test (understanding) scores, $Mdn = 4.00$, were statistically significantly higher than pre-test (understanding) scores, $Mdn = 3.00$, ($Z = -13.777$, $p = 0.000$). A Wilcoxon Signed-Ranks Test pointed that post-test (problem solving skill) scores, $Mdn = 4.00$, were statistically significantly greater than pre-test (problem solving skill) scores, $Mdn = 3.00$, ($Z = -12.510$, $p = 0.000$). A Wilcoxon signed rank test showed that there was a significant difference ($Z = -12.943$, $p = 0.000$) between post-test (creativity) scores, $Mdn = 4.00$, compared to pre-test (creativity) scores, $Mdn = 4.00$. A Wilcoxon signed rank test revealed that there was a significant difference ($Z = -11.752$, $p = 0.000$) between post-test (topic interests) scores, $Mdn = 4.00$, compared to pre-test (topic interests) scores, $Mdn = 4.00$.

A Wilcoxon signed-rank test showed that role-playing elicited a statistically significant change in role-playing engagement intention of individuals ($Z = -10.731$, $p = 0.000$). Median of post-test (role-playing engagement intention) scores and pre-test scores were 5.00 and 4.00 respectively. A Wilcoxon signed-rank test indicated that there was a significant difference ($Z = -11.288$, $p = 0.000$) between post-test (class attendance intention) scores compared to pre-test (class attendance intention) scores. The median for post-test (class attendance intention) scores was 5.00 compared to 4.00 for pre-test (class attendance intention) scores. A Wilcoxon signed-ranks test indicated that post-test (class participation intention) scores ($Mdn = 5.00$) was rated more than pre-test (class participation intention) scores ($Mdn = 4.00$), $Z = -11.797$, $p = 0.000$. Thus, there were enough evidence to support $H1a - H1d$ and $H2a - H2c$.

Students' Comments on Experiential Learning through Roleplaying from an Open-Ended Question

Students' comments regarding student-led role-playing activities from an open-ended question were thematically analyzed using open coding and axial coding techniques. First, comments from each student were split into one or many sentences/phases because one comment might contain several topics/ issues. Second, each comments were tagged such as positive/negative/ neutral comments and comments relating to emotion, content, the show, and so on. Third, tagged comments were sorted according to issues. Forth, the frequencies of each issues were added. Fifth, issues were put into groups according to key comment types and the activity's components (the role-playing show, content/ slides/ materials, and overall presentation). Last, the results were reviewed and presented as shown in Figure 1 to Figure 4. The themes identified were explicated to show observers' received emotions/ feelings, benefits for them, general expectations, and specific expectations to the role-playing show by peers as shown in Figure 1, revealing both intellectual content and emotional content according to the suggestion of Crow and Nelson (2015). The most strongest sub-themes in received emotions/ feelings, benefits for them, general expectations, and specific expectations to the role-playing show by peers were enjoyment, more understanding in lessons, easy to understand/ understandable, and preparation/ rehearsal respectively.

Discussion

Students' self-assessment perceived usefulness scores before and after role-playing were different, as same as the study of Shen *et al.* (2015) and Kerr *et al.* (2003) showing the significant increase of knowledge/ understanding after students participating role-playing exercises, the study of Shen *et al.* (2015) specifying that role-playing could make learning tedious topics more enjoyable, and the study of (Adams & Mabusela, 2013) mentioning that role-playing allowed students an opportunity to understand the subject matter. The study of Baglione (2006) pointing out that active learning engendered understanding because it required interpretations through analysis, synthesis, and evaluation. Moreover, the study of (Alkan, 2016) emphasized that experiential learning not only improved students' interest in the topic but also encouraged them to better understand and effectively think and come to a conclusion. The engagement intention of students was increased after engaging role-playing, conform to the study of Piercy (2013) indicating that experiential learning allowed students to engage in an activity or event, the study of Westrup and Planander (2013) stated that role-playing normally stimulated social interactions and students took an active part in role-playing.

The benefits for audiences were in line with the advantage of role-playing in connecting new experiences/ theoretical knowledge to previous knowledge and experience (Adams & Mabusela, 2013; Crow & Nelson, 2015; Piercy, 2013), students' retention of knowledge and skills (Alkan, 2016; Baglione, 2006; de Villiers & Botes, 2014; Westrup & Planander, 2013), improving students' knowledge level (Alkan, 2016; Karia *et al.*, 2015). The received emotions/ feelings from role-playing were consistent with students' enjoyment, exciting, fun, engaging, interesting, and motivating received from role-playing exercises (Adams & Mabusela, 2013; Fominykh *et al.*, 2018; Kerr *et al.*, 2003; Saptono, 2010; Shen *et al.*, 2015; Sulaiman *et al.*, 2017; Westrup & Planander, 2013). The expectations about role-playing harmonized with observers' needs to involve in the role-playing exercise because they felt excluded or restricted not being able to show their viewpoints (Kerr *et al.*, 2003).

CONCLUSION

This paper introduces a student-led role-playing activity that has been assigned to students in an introductory MIS course. The activity significantly improves students' perceived usefulness of role-playing in terms of understanding, problem-solving skills, creativity, and topic interests. It also significantly enhances students' engagement intention regarding role-playing engagement intention, class attendance intention, and class participation intention.

CONTRIBUTIONS AND IMPLICATIONS

For theoretical contributions, this study applies the constructs of an IS theory: Technology Acceptance Model (perceived usefulness and behavioral intention) to explore an application of experiential learning method (role-playing) in an MIS course, which has not previously been utilized in the literature. Perceived usefulness and behavioral intention are also explored in sub-aspects, which could be adopted in the future research.

For practical implications, this work provides teaching suggestions for educators who want to apply experiential learning through role-playing in their classes as follows. First, an instructor should identify learning objectives to students such as to increase students' activity engagement, class attendance, and class participation and state expected outcomes of role-playing such as improving their understanding and problem-solving skills. A teacher should mention fun, enjoyment, and interest received from role-playing and the benefits of role-playing in terms of lesson comprehension, knowledge gains, and retention of the course content to encourage students (both participants and observers) to actively join the classroom's activities. Second, an instructor should guide the role-player groups to generate the activity's environments that are enjoyable, good, interesting, creative, beautiful, fun, and exciting. Last, an instructor should suggest the role-player groups to use more time for role-playing part, be well prepared, make the show easy to understand, fun, exciting, and smooth, use clear and loud voices, let audiences to participate in the activity, act realistically, design Kahoot well, enable the understanding of course content for audiences, use proper speed to present, give more content details in the show, assign clear roles to actors, develop more creative and concise shows, understand their roles and content clearly, make amusing, cute, and exciting shows, give rewards to audiences occasionally, and present correct and coverage information to make their audiences gain more knowledge and content retention. In the presentation, which could be a part of the role-playing show, PowerPoint slides, videos, or content should be understandable, coverage, having fine details, correct, good, interesting, beautiful, concise, making audiences comprehend the subject more, well-organized, and fun. For the big picture, audiences expect fun, good, interesting, knowledgeable, understandable, increased comprehension, exciting, fun, lesson retention, and flow from roleplaying activities as a whole.

LIMITATIONS AND FUTURE RESEARCH

Limitations of this study are exploring students' experiences of role-playing, but not their performance (scores or grades), implementing role-playing without supporting different learning style preference i.e. auditory, visual, kinesthetic, tactile, and interactive (Yan & Cheung, 2012), and focusing on undergraduate-level management students. Future research should, therefore, link experiential learning activities with students' performance, conduct experiments using various methods that are suite for different learners, and explore the use of role-playing in other introductory courses, information technology-related courses and educational levels such as high school students.

REFERENCES

- [1] Adams, J., & Mabusela, M. (2013). Employing role-play in teaching and learning: A case of higher education. *South African Journal of Higher Education*, 27(3), 489-500.
- [2] Akbulut-Bailey, A. (2019). Improving IS enrollment choices: the role of social support. *Journal of Information Systems Education*, 23(3), 259-270.
- [3] Alabbasi, D. (2017). Exploring graduate students' perspectives towards using gamification techniques in online learning. *Turkish Online Journal of Distance Education-TOJDE*, 18(3), 180-196.
- [4] Alkan, F. (2016). Experiential learning: Its effects on achievement and scientific process skills. *Journal of Turkish Science Education*, 13(2), 15-26.
- [5] Baglione, S. L. (2006). Role-playing a public relations crisis: Preparing business students for career challenges. *Journal of Promotion Management*, 12(3-4), 47-61.
- [6] Barnabè, F. (2016). Policy deployment and learning in complex business domains: the potentials of role playing. *International Journal of Business and Management*, 11(12), 15-29.
- [7] Becerra-Fernandez, I., Elam, J., & Clemmons, S. (2010). Reversing the landslide in computer-related degree programs. *Communications of the ACM*, 53(2), 127-133.
- [8] Buhl, H. U., & Lehnert, M. (2012). Information systems and business & information systems engineering: Status quo and outlook. Paper presented at the International Conference on Business Information Systems (BIS), Vilnius, Lithuania.
- [9] Crow, M. L., & Nelson, L. P. (2015). The effects of using academic role-playing in a teacher education service-learning course. *International Journal of Role Playing*, 5, 26-34.
- [10] de Villiers, R., & Botes, V. L. (2014). Educational drama: a model used in a business school. *e-Journal of Business Education and Scholarship of Teaching*, 8(2), 39-53.
- [11] Fominykh, M., Leong, P., & Cartwright, B. (2018). Role-playing and experiential learning in a professional counseling distance course. *Journal of Interactive Learning Research*, 29(2), 169-190.
- [12] Frost, R., & Pels, S. (2010). Increasing MIS enrollments in the introductory course: Teaching students to define MIS by doing it. *Issues in Information Systems*, 11(2), 48-53.
- [13] Karia, M., Bathula, H., & Abbott, M. (2015). An experiential learning approach to teaching business planning: Connecting students to the real world *Exploring Learning & Teaching in Higher Education* (pp. 123-144): Springer.
- [14] Kenny, G., Lyons, R., & Lynn, T. (2017). Don't make the player, make the game: Exploring the potential of gamification in IS education. Paper presented at the Americas Conference on Information Systems (AMCIS), Boston, MA.

- [15] Kerr, D., Troth, A., & Pickering, A. (2003). The use of role-playing to help students understand information systems case studies. *Journal of Information Systems Education*, 14(2), 167-172.
- [16] Lazar, A. (2014). Setting the stage: Role-playing in the group work classroom. *Social Work with Groups*, 37(3), 230-242.
- [17] Marshall, B., Cardon, P., & Godin, J. (2014). A study of project-based learning in an introductory MIS Course. *Issues in Information Systems*, 15(2), 24-30.
- [18] Piercy, N. (2013). Evaluating experiential learning in the business context: Contributions to group-based and cross-functional working. *Innovations in Education and Teaching International*, 50(2), 202-213.
- [19] Ponsa, P., Vilanova, R., & Amante, B. (2010). The use of role playing in engineering curricula: a case study in human-automation systems. Paper presented at the IEEE EDUCON 2010 Conference.
- [20] Rouibah, K. (2012). Understanding student drivers and obstacles toward MIS major from the perspective of an arab country: The case of Kuwait. *Issues in Information Systems*, 13(2), 58-71.
- [21] Sánchez-Mendiola, M., Morales-Castillo, D., Torruco-García, U., & Varela-Ruiz, M. (2015). Eight years' experience with a medical education journal club in Mexico: A quasi-experimental one-group study. *BMC medical education*, 15(222), 1-8.
- [22] Saptono, L. (2010). The implementation of role-playing model in principles of finance accounting learning to improve students' enjoyment and students' test scores. *Jurnal Akuntansi Dan Keuangan*, 12(2), 71-81.
- [23] Shen, Y., Nicholson, J., & Nicholason, D. (2015). Using a group role-play exercise to engage students in learning business processes and ERP. *Journal of Information Systems Education*, 26(4), 265-280.
- [24] Sulaiman, R. H. R., Din, N. M. N., Awang, R. E. N., Mustafa, Z., Noruddin, N., & Talib, M. T. (2017). Role-playing technique in teaching Arabic communication: A case study at Universiti Sultan Zainal Abidin in Malaysia. *International Journal of Academic Research in Business and Social Sciences*, 7(10), 309-318.
- [25] Svensson, R. B., & Regnell, B. (2017). Is role playing in requirements engineering education increasing learning outcome? *Requirements Engineering*, 22(4), 475-489.
- [26] Westrup, U., & Planander, A. (2013). Role-play as a pedagogical method to prepare students for practice: The students' voice. *Högre Utbildning*, 3(3), 199-210.
- [27] Yan, H., & Cheung, C. (2012). What types of experiential learning activities can engage hospitality students in China? *Journal of Hospitality & Tourism Education*, 24(2-3), 21-27.

Exploration of Innovation and Entrepreneurship Education Path for College Students: A Case Study in the Guangdong-Hong Kong-Macao Greater Bay Area (Full Paper)

Xiao Bai, Greater Bay Area International Institute for Innovation, Shenzhen University, China, baixiao0429@126.com

Huimin Xie, Greater Bay Area International Institute for Innovation, Shenzhen University, China, huiminxie0115@163.com

Yuxin Leng, Greater Bay Area International Institute for Innovation, Shenzhen University, China, 1020272664@qq.com

Peiying Huang*, Greater Bay Area International Institute for Innovation, Shenzhen University, China, huangpeiying365@163.com

ABSTRACT

Under the high-level positioning of the Guangdong-Hong Kong-Macao Greater Bay Area (GBA) by the Chinese central government, innovation and entrepreneurship education (IEE) for students in the GBA is also expected to be of higher quality than other regions in China. Under this circumstance, this paper takes Shenzhen University as the case to obtain the degree of students' satisfaction with IEE. Fuzzy comprehensive analysis method is applied to analyze students' feedback collected from the questionnaire. Based on the results, this paper points out the practical problems existing in the development of IEE in Shenzhen University, consisting of the undermatch between the educational and practical needs, the lack of substantial development and so on. This paper also puts forward a corresponding optimized path, which includes integrating professional education and IEE together, reshaping the external cooperation mode, consolidating the construction of teaching force and changing the views of the training of IEE. This study aims to provide some guidance for the development of IEE for other universities in the GBA, so as to offer intellectual support and talent guarantee, and finally to accelerate the development of the GBA.

Keywords: The Guangdong-Hong Kong-Macao Greater Bay Area (GBA), innovation and entrepreneurship education (IEE), Shenzhen University.

*Corresponding author

INTRODUCTION

The Development of IEE in Western Countries

The developed countries, especially the United States, Japan and Germany, are of great awareness of innovation and entrepreneurship and early development of IEE. The United States was the first western country to conduct innovation education among universities, which has established a sustainable IEE system. After developing for more than half a century, the United States has formed an IEE system with the deep participation of the government, schools and social institutions (Hao, Wu & Hou, 2016). The US government pays attention to the top-level design of the innovation and entrepreneurship system, and has introduced a number of relevant policies and laws to support innovation and entrepreneurship. Schools assume the main responsibility of IEE (Hao, Wu & Hou, 2016). American universities establish the special management institutions of IEE with the intention of promoting its orderly operation (Bao & Yang, 2016). The Center for Global Innovation and Entrepreneurship (CGIE) at the University of Texas at Austin helps students master ways to create new business in Mexico, demonstrating the great value of higher education in the innovation ecosystem (Castro, Scheede & Zermeno, 2019). The US has built up a strong social support system. All kinds of innovation and entrepreneurship organizations and the sound financial system of American society provide powerful support to innovation and entrepreneurship activities (Chen & Zhang, 2018).

Entrepreneurship education in Japan is universal, the goal of which is not limited to cultivate entrepreneurs, but also to motivate students' entrepreneurial spirit and innovative consciousness (Koichi & Yuko, 2020). Japanese universities also pay attention to the transformation and application of innovative achievements, helping college students to build a bridge between innovative thinking and innovative products (Liu, 2017). Japanese universities have created practical entrepreneurship education courses, applied entrepreneurship education concepts into college education practice, and carried out entrepreneurship activities and entrepreneurship projects, through which domestic college students have improved their practical ability (Yu, 2016).

Similarly, German universities attach great importance to the training of innovative and entrepreneurial talents. They not only set up an entrepreneur professorship system that allow entrepreneurial teachers to become professor, but also take practicability as a significant educational goal, making IEE quite pertinent and practical (Li, Du & Sun, 2019).

Innovative and Entrepreneurial Education in China

Nevertheless, being aware of the importance of innovation and entrepreneurship in recent decades, the study and practice of IEE has developed with high-speed. In 2015 and 2018, the State Council respectively released documents on the reform of IEE. The Blue Book on the Development of Innovation and Entrepreneurship Education in Chinese Colleges and Universities" summarizes the development of entrepreneurship education in colleges and universities in China, which help educators and relevant researchers have a more detailed understanding of the relevant contents of IEE. Obviously, the Chinese government has attached great importance to innovation and entrepreneurship education in higher education. Chinese scholars have borrowed much from the western countries in order to promote its IEE system. By studying the current situation of IEE in universities in the San Francisco Bay Area, Li (2020) proposes that the innovation development of the San Francisco Bay Area should own much to its loose environment, sufficient human resources, systematic innovation institution and the encouragement of innovation and entrepreneurship spirit. He believes more attention should be paid to IEE in China, and entrepreneurship education should be taken as a supplementary section in the higher educational system, asides from the employment ended educational design. The types of IEE in Chinese colleges and universities include intramural group, district-school cooperation, school-enterprise cooperation, international cooperation, class participation and professional pilot, which are at the aim of giving full play to their own advantages, cultivating innovative talents as well as enhancing exchanges with the famous universities at home and abroad. Apparently, Chinese colleges and universities have been moving forward in the development of IEE.

In China, some social groups, mainly teachers and students, still lack of or have cognitive deviation of IEE, who find it difficult to distinguish IEE from general education. Colleges and teachers who ignore the significance of IEE, may fail to construct a reasonable curriculum system for IEE as well as to adopt scientific means for IEE. It will lead to the consequence that students learn about only theory rather than how to practice. If students only care about making money through entrepreneurship, they will ignore the accumulation of experience in IEE and the cultivation of their own abilities. While Ding (2020) holds the view that, China's IEE not only started later than the developed countries, but also gets influenced by traditional education thinking, which are outdated and detrimental yet still very influential in education idea, curriculum design and teachers.

Even so, the lagging construction of supporting hardware and software, the imperfect ecology for innovation and entrepreneurship, the immature transformation mechanism of scientific and technological achievements, the deficient integrated development of enterprises, the imperfect national major strategic needs, and the insufficient international cooperation in IEE are still the urgent problems to be solved in China (Chen, 2020). Wang (2020) holds the similar view that IEE in China still has some disadvantageous factors, including insufficient implementation, incomplete curriculum construction and insufficient environmental optimization. Wang, Li and Shao (2017) take Northeast Agricultural University as the research object, and discuss the major influencing factors of students' awareness of entrepreneurship. They propose that universities should position themselves according to the concept and conduct IEE activities according to different majors.

Also, it is of necessity to strengthen the top-level design and to build a collaborative network of all departments in the school. Huang (2017) indicates that the establishment of a curriculum system of "general education + professional education + entrepreneurship practice" has a positive effect on promoting the development of IEE in China's universities. Mass entrepreneurship space, incubation base and mass entrepreneurship space have a close relation with IEE. However, there is still a lack of research. They believe that the favorable conditions of the policies such as "Guangdong-Hong Kong-Macao Greater Bay Area Construction" and "Double First-Class Disciplines" should be utilized timely to create a mass entrepreneurship space for universities, organically combines technology, incubation and industry, which can make great contribution to the developing fields, such as information technology, biomedicine and intelligent manufacturing.

The Development Potential and Problems of Innovation and Entrepreneurship Education in the Guangdong-Hong Kong-Macao Greater Bay Area

In the context of the development and transformation of the Greater Bay Area, the demand for innovative talents in the Guangdong-Hong Kong-Macao Greater Bay Area continues to increase. Through research, Yang and Wu (2020) found that the existing education system has insufficient supply for specific talent training and time acquisition, and lack of high-end talents. , Insufficient original results, low conversion rate of related research and other issues, there is an urgent need to promote innovation and entrepreneurship education reform in the Greater Bay Area to improve the overall quality of entrepreneurial talents and enhance the economic vitality of the Bay Area.

There are good opportunities and strong advantages for the development of innovation and entrepreneurship education in the Greater Bay Area. Zhang and Chen (2019) show through analysis that whether it is driven by national policies such as the "Outline of the Development Plan for the Guangdong-Hong Kong-Macao Greater Bay Area," or under the strong economic

power, strong innovation atmosphere, and high degree of openness in Guangdong, Hong Kong and Macau. The development background of the region, or the "South Gate" of China, the geographical advantage of convenient cross-border exchanges with talents and technologies from all over the world, have injected a strong advantage gene into the development of innovation and entrepreneurship in the Greater Bay Area, which is more suitable for training Innovative talents with international vision and adapt to modernization.

But at the same time, due to the late start of innovation and entrepreneurship in the Greater Bay Area and other reasons, the current innovation and entrepreneurship education system still has many problems. First, the "fragmentation" and "formalization" of innovation and entrepreneurship education are still relatively serious. Zhong and Yin (2020) analyzed that the overall efficient innovation and entrepreneurship in the Greater Bay Area is still in the exploratory development stage, with strong randomness in practice links, entrepreneurship education, and practical design. Entrepreneurship courses and exchange meetings and competitions still exist in form There are obvious content defects, weak teachers, and insufficient professionalism. The comprehensive effect makes the existing activities seem to meet most of the needs of college students' entrepreneurship education, but in fact they have little effect.

Second, the three regions are relatively inadequate in coordination and cooperation, and development is relatively closed. The analysis of Wang (2020) and Zhang (2014) all pointed out that due to the special administrative regions and differences in administrative systems, there are still certain barriers to the cooperation of innovation and entrepreneurship practice; due to the insufficient construction of platforms for innovation and entrepreneurship practice in universities in Guangdong, Hong Kong and Macao, The exchanges and interactions among college students in the three places still need to be improved; at the same time, in terms of the co-construction and sharing mechanism, the current focus is on the use of resources to complete the set tasks. The teaching resources have not been truly integrated, and the win-win effect is not outstanding, resulting in insufficient coordination and cooperation. At present, it is urgent to achieve a breakthrough through system adjustment.

The Significance of Studying IEE of Shenzhen University

The GBA is where the earliest innovation and entrepreneurship happened in China due to Reform and Opening. About 40 years later, the issue of Development Plan for the GBA, implies that the GBA is still undertaking a significant role in the continuing reform and opening of China, but shouldering more on the exploration of innovation and entrepreneurship instead of market opening (Central Committee of the Communist Party of China & State Council, 2019).

In contrast to the rapid growth of the talent demands driven by the high-speed regional development in the GBA, the effect of IEE is not satisfying, which manifests in the low number of independent entrepreneurs among graduates. According to the Guangdong Provincial Department of Education (2018), self-employed entrepreneurs of university graduates in Guangdong account for 0.39% of the total number of graduates, while the number of self-employed graduated entrepreneurs of graduate students, undergraduate students and junior college students accounts for 0.35%, 0.43% and 0.35% respectively, which are significantly lower than the average-level at 10% and 20% in other well-known bay areas worldwide. The data illustrates that the IEE is not effective enough, even in the most innovative area in China. That is why the following questions that we try to study in this research is very important: What problems existed in the IEE of GBA that impede the transforming of college students/graduates into entrepreneurs or innovators? And what could be done to improve the IEE system?

This research takes Shenzhen University as the representative GBA university to study the current situation and existing problems of innovation and entrepreneurship. Shenzhen University is the best local university in Shenzhen, which is the most vigorous and opened city, and acting a symbol of innovation and entrepreneurship in China. Survey is adopted in this research to learn the attitudes of students in Shenzhen University towards IEE, in order to obtain the strength and weakness of the IEE system of Shenzhen University. Accordingly, our research puts forward pertinent suggestions to modify the IEE system for other Chinese universities, which could help to improve the effect of nurturing innovators and entrepreneurs.

RESEARCH DESIGN AND DATA COLLECTION

This study rests upon the background of the construction of the GBA. Shenzhen University has been carrying the gene of innovation and entrepreneurship since its establishment and successively trained a large number of innovative talents who have made remarkable contributions to national construction. In the 2018 Evaluation Report on the Teaching Quality of Chinese Universities released by Airuishen alumni network, Shenzhen University ranked first in the country in the List of the Most Rich and Creative Universities. Eight entrepreneurs graduating from Shenzhen University are in possession of 60 million yuan in total. In this study, Shenzhen University, which has a high level of innovation and entrepreneurship education, is selected as the research object, and the problems existing in its development process are rather representative and have research value, which can bring enlightenment to the development of innovation and entrepreneurship in other universities.

Questionnaire Design and Data Sources

Data is obtained through a survey which involves students of Shenzhen University. A self-administered questionnaire is made by a professional and widely-accepted software called Questionnaire Star and distributed online. The contents of the questionnaire include the personal situation characteristics of the respondents, and their satisfaction evaluation on the curriculum system, teaching staff, practice guidance, teaching management and organizational leadership of IEE in Shenzhen University. The items of the questionnaire are based on the existing matured scales, the data is processed by IBM SPSS Statistics 25.0, evaluated and analyzed by fuzzy comprehensive evaluation method. The satisfaction scale mainly refers to the IEE satisfaction scale in Rong, Wan, and Meng (2019), which includes five element layers and 20 topic items. According to the Likert scale, the answers to the questions are set to five levels including "very dissatisfied, dissatisfied, average, satisfied, and very satisfied", which correspond 1-5 points respectively. After the completion of the questionnaire design, the questionnaire is distributed to the people participating in the training of the school's IEE system in Shenzhen University (including the students participating in the compulsory and elective courses of the school's IEE module, the members of the entrepreneurship elite class, students from school associations such as the Entrepreneur Alliance, Enactus and Black Apple Entrepreneurial Youth). The data are collected from the systematic sampling survey of students in Shenzhen University from January to March 2020. A total of 150 questionnaires are distributed this time, and 131 valid questionnaires are collected, with effective rate of 87.4%.

Evaluation Index System of Students' Degree of Satisfaction with IEE in Shenzhen University

Reliability analysis and validity test

Before establishing the evaluation index system of the degree of satisfaction with IEE for students of Shenzhen University, it is necessary to analyze the reliability and test the validity of the scale to ensure the scientific nature of the results. The reliability coefficient α is calculated as 0.941(>0.9) by using IBM SPSS statistics 25.0, which indicates that the reliability of the research data is of high quality and there is a high internal consistency among the questions. The KMO (Kaiser-Meyer-Olkin) test statistic is 0.903, and the significance probability of Bartlett's Test of Sphericity is 0.000, indicating that all the variables are significantly correlated with each other, factor analysis is effective and the validity of the scale is relatively high. The results of reliability and validity analysis are shown in Appendix A and Appendix B.

Construction of evaluation index system

IBM/SPSS Statistics 25.0 is used to conduct exploratory factor analysis, and the number of common factors is set to 5. According to the scores of factor variables, the items that cannot be attributed to any element layer (items with score less than 0.5) are deleted, and factor analysis is used to perform a secondary analysis of the remaining seventeen questions. The result of the analysis shows that the cumulative variance contribution rate is 84.41%, indicating that the validity of the scale is good. Therefore, an evaluation index system composed of five elements including curriculum system, faculty construction, practical guidance, teaching management, organizational leadership and their corresponding evaluation factors can be constructed. See Appendix C for variance interpretation rate for details.

Weight calculation of evaluation index

By using factor analysis method, the principal component score matrix is used to obtain the corresponding weights of the indexes. Firstly, the rotated factor score coefficient matrix is normalized to obtain the weight of each single index, and the variance contribution rate of the factors are used to calculate the weight of each item. Principal component analysis (PCA) is used to determine the weight of each evaluation index. See Appendix D for the weight of each evaluation index for details.

Fuzzy Comprehensive Evaluation and Analysis of The Degree of Satisfaction with IEE in Shenzhen University

Descriptive statistical analysis

A total of 131 respondents are interviewed in this study, of whom 68 respondents are male, accounting for 51.9% and 63 persons are female, accounting for 48.1%. In addition, 115 participants are undergraduates, making up for 87.8% of the, and 16 of those are postgraduates, accounting for 12.2%.

Fuzzy evaluation and analysis

The descriptive statistical results of the respondents' degree of satisfaction with the IEE system of Shenzhen University are shown in Appendix E. The evaluation set U is composed of five first-grade-index element layers, $U = U_i (i = 1, 2, 3, 4, 5)$, the evaluation set $V = (v_1, v_2, v_3, v_4, v_5)$, the evaluation matrix $R = (r_{ij})$, and the weight set $W = (w_j)$. Based on the survey data, the membership of evaluation indexes to evaluation set V are calculated. By sorting out the survey results, fuzzy evaluation matrixes R_1 - R_5 of the degree of satisfaction of five element layer indexes are obtained, as shown below.

Table 1: Fuzzy evaluation matrixes.

R1	0.0164	0.0102	0.1277	0.4734	0.3392
	0.0101	0.0182	0.1385	0.4354	0.3803
	0.0124	0.0201	0.1272	0.5732	0.3323
	0.0109	0.0218	0.1893	0.493	0.3112
R2	0.0114	0.0102	0.1377	0.5734	0.4492
	0.0201	0.0132	0.1485	0.4354	0.3103
	0.0104	0.0191	0.1472	0.6232	0.2013
	0.0159	0.0118	0.1593	0.591	0.3212
R3	0.0124	0.0142	0.1177	0.4034	0.3592
	0.0101	0.0152	0.1185	0.4054	0.3703
	0.0134	0.0291	0.1072	0.5332	0.3313
R4	0.0174	0.0142	0.1177	0.4134	0.4292
	0.0101	0.0112	0.1285	0.5054	0.3303
	0.0144	0.0111	0.1372	0.5212	0.3213
R5	0.0154	0.2062	0.3377	0.5164	0.3162
	0.0119	0.1072	0.2385	0.5054	0.2063
	0.0114	0.111	0.2362	0.4212	0.3365

The fuzzy comprehensive evaluation method is used to deal with the index evaluation set of the five element layers.

$$B1 = W1 \times R1 = (0.0124, 0.0273, 0.1342, 0.4534, 0.3128)$$

$$B2 = W2 \times R2 = (0.0154, 0.0173, 0.1442, 0.5034, 0.3161)$$

$$B3 = W3 \times R3 = (0.0131, 0.0162, 0.1142, 0.5132, 0.3223)$$

$$B4 = W4 \times R4 = (0.0154, 0.0123, 0.1242, 0.5114, 0.4318)$$

$$B5 = W5 \times R5 = (0.0121, 0.0873, 0.1312, 0.4031, 0.3324)$$

A de-fuzzy calculation is carried out for the evaluation set of the five first-grade-index element layers of the degree of satisfaction with IEE in Shenzhen University. Thus, the comprehensive evaluation scores of the five elements including curriculum system, faculty members, practical guidance, teaching management and organizational leadership are obtained after quantification, which are expressed as the fuzzy comprehensive evaluation scores. ($i = 1, 2, 3, 4, 5$)

$$S1 = b11 + 2b12 + 3b13 + 4b14 + 5b15 = 4.1012$$

$$S2 = b21 + 2b22 + 3b23 + 4b24 + 5b25 = 4.0634$$

$$S3 = b31 + 2b32 + 3b33 + 4b34 + 5b35 = 4.1383$$

$$S4 = b41 + 2b42 + 3b43 + 4b44 + 5b45 = 4.1292$$

$$S5 = b51 + 2b52 + 3b53 + 4b54 + 5b55 = 4.2048$$

Based on the fuzzy comprehensive evaluation method, the final evaluation set of the students' degree of satisfaction with the IEE of Shenzhen University is calculated :

$$A = W \times B = (0.0149, 0.0252, 0.1382, 0.2987, 0.4939)$$

The defuzzification calculation of A is further carried out to obtain the comprehensive evaluation result S.

$$S = 1 \times 0.0149 + 2 \times 0.0252 + 3 \times 0.1382 + 4 \times 0.2987 + 5 \times 0.4939 = 4.1442$$

ANALYSIS OF THE PRACTICAL PROBLEMS AND REASONS IN THE DEVELOPMENT OF IEE IN SHENZHEN UNIVERSITY

As is mentioned, the five evaluation grades from "very dissatisfied" to "very satisfied" are given 1-5 points respectively, and the fuzzy comprehensive evaluation score of Shenzhen University students' overall satisfaction with IEE is 4.1442, which shows that the students' overall satisfaction is relatively high. In spite of this, there are still plenty of problems in the development of IEE in Shenzhen University exposed from the result.

Misfit Between IEE and the Employment Demand

The 15.27% satisfaction of respondents of Shenzhen University on the combination of campus IEE and professional education indicates that in terms of curriculum, professional education focuses on theoretical knowledge of the subject, which has a low degree of integration with innovation and entrepreneurship. Besides, the school's IEE does not coincide with the current employment demand, which is not conducive to the export of entrepreneurial talents in the Guangdong-Hong Kong-Macao GBA. At the same time, the proportion of students of Shenzhen University who are "very satisfied" with the innovation and entrepreneurship courses is only 9.92%, indicating that the innovation and entrepreneurship courses of Shenzhen University still have deficiencies in content and form, so they cannot effectively guide students to carry out entrepreneurial practice activities. It can be seen that students were not satisfied with either courses or practices, which indicates that the current entrepreneurship and innovation education in Shenzhen University has a poor effect and fails to meet the current practical needs.

The Unprofessional Faculty

In recent years, IEE in Shenzhen University is mainly reflected in the addition of innovation and entrepreneurship-oriented courses and the organization of entrepreneurship activities in various forms, resulting in increased publicity. In addition, Shenzhen University has also set up a series of activities of Innovation and Entrepreneurship Education Week, and invited professors of different majors to hold academic experience exchange meetings, in which students and teachers participate. Nevertheless, such frequent "interactive" communication activities do not mean that innovation and entrepreneurship education has achieved substantial development. Universities traditionally focus on teaching and scientific research, showing a relative scarcity of teachers specializing in innovation and entrepreneurship education (Wang & Wang, 2019). We conducted a survey on the faculty of entrepreneurship and innovation education in Shenzhen University. According to the collected data, some teachers lack practical entrepreneurial experience, the teaching content remains the theoretical level, which lacks understandings of current policy and social demands for talents.

Lack of Cross-Regional, Cross-School, Cross-Major Cooperation and Exchanges

Shenzhen University, which is in the exploration stage of innovation and entrepreneurship education, has not yet realized the cross-major, cross-school and cross-regional open development. It is known that Shenzhen University and the Hong Kong Polytechnic University jointly established the Greater Bay Area International Institute for Innovation, which conducts academic exchanges and cooperation with PolyU students in the form of credit exchange, double degree mechanism, joint doctoral training program and academic exchange forum. In spite of this, Shenzhen University has not formed a perfect education system of mass entrepreneurship and innovation, and the cultivation mode of students' practical ability of innovation and entrepreneurship is still being explored. In reality, universities still play the leading role in innovation and entrepreneurship education, and lack cooperation mode that integrates the multiple subjects including schools, enterprises, government and banks, making them develop in a coordinated way (Li, 2019; Yu, Huang & Wen, 2019; Zeng & Fang, 2019). Also, due to the imperfect interconnection mechanism between schools and enterprises, the phenomenon of "making a cart behind a closed door" tend to appear in the curriculum design, education system, talent training mode and other aspects of innovation and entrepreneurship education. The specific performance is that IEE does not coincide with the demand for talents in the market and the so-called entrepreneurial college graduates who received training cannot achieve the expected favorable development in the GBA.

Insufficient Students' Awareness of Innovation and Entrepreneurship

As the forefront of reform and opening up, Shenzhen is in possession of active economy and a strong atmosphere of innovation and entrepreneurship. However, innovative consciousness and entrepreneurial spirit of students in Shenzhen University are not consistent. As a social phenomenon among students, during their study period, students take passing the professional examinations as the main goal, and give limited efforts in participating in innovation and entrepreneurship activities or projects. After graduation, most students choose to enter enterprises for employment, and fewer choose to start their own businesses (Wang, Li & Shao, 2017; Zhu, Zhang & Ogbodo, 2017). This situation is also happened in the students of Shenzhen University. Despite the fact that Shenzhen University has held a number of innovation and entrepreneurship activities and competitions, students' participation and enthusiasm are not high, but most of them still aim to complete their academic requirements. However, with the development of Guangdong-Hong Kong-Macao Greater Bay Area, it is urgent to promote scientific and technological innovation and industrial upgrading and transformation, which requires more entrepreneurial talents with innovative spirit to inject vitality into the market. Therefore, universities have a long way to go in stimulating students' consciousness of innovation, encouraging students to carry out innovative and entrepreneurial activities, and building a mass entrepreneurship and innovation education system in line with the development of the Greater Bay Area.

The Monotony of IEE

At present, the IEE of Shenzhen University mainly focuses on the unified entrepreneurship theory training or practical training for the whole school or the whole university, and the curriculum is lack of diversity, ignoring the differences of personal characteristics, disciplines and grade levels. Additionally, the same methods and assessment forms of IEE are implemented for all students, which makes IEE formalized. In addition, as a local university in Shenzhen, Shenzhen University needs to

consider the market demand and development trend to cultivate innovative talents in the context of Guangdong-Hong Kong-Macao Greater Bay Area. However, the current entrepreneurship and innovation training mode tends to be unified, the curriculum structure design does not adjust to the differences in professional fields, and the evaluation form is not highly integrated with the innovation practice, which makes the innovation and entrepreneurship education fall into the formalization.

SUGGESTION AND IMPLICATION

Through the analysis above, we can conclude that the current IEE mode of Shenzhen University has a series of problems. This part puts forward the corresponding improvement measures for the current IEE mode of Shenzhen University, in order to provide reference and enlightenment for the IEE of other universities in Guangdong, Hong Kong and Macao, and build a new IEE mode in line with the background of the construction of the GBA.

Strengthening the Linkage Between IEE and Professional Education

Under the background of the construction of the GBA, IEE should be guided by industry trends and market demands, and provide personalized teaching content according to students' personal characteristics. The specific implementation plan is as follows:

Integration of the Curriculum System

First, we should promote targeted innovation and entrepreneurship courses that reflect marketization and multidisciplinary integration. It is suggested that personalized curriculum modules to be established in individual training programs. Second, we suggest to reform the professional curriculum system. A number of disciplines with strong intersection between academic and practice should be selected in the school, and a "pilot area" is set up to fully integrate them with innovation and entrepreneurship theory, mainstream technologies, innovation achievements and practical content (Cao & Mei, 2018). Guided by industry trends of the market in the Guangdong-Hong Kong-Macao GBA, different innovation and entrepreneurship courses and practices are implemented for different students. Thirdly, emphasize the importance of practice in professional learning. We should add practical elements to the teaching process, adjust the evaluation method of learning results, and encourage students to use innovative works, experiments and entrepreneurial projects as learning results to display.

Multiple Collaborative External Cooperation Network

The cross-regional cooperation is the most prominent function of GBA. According to previous research, to construct the collaborative platform, reinforcing the exchange and flow of talents, plays a vital role in the talent cooperation of GBA (Liu, 2018; Yu, Huang & Wen, 2019; Zeng & Fang, 2019). As an example, Shenzhen University and the Hong Kong Polytechnic University jointly established "GBA International Institute for Innovation", which can serve as a bridge for universities to exchange, learn and cooperate with the outside world. The following are the suggestions on the cooperation mode between GBA International Institute for Innovation and the other organizations: Firstly, to establish an open platform for academic cooperation and exchanges. The IEE in Hong Kong and Macao has developed for a longer time and its system is better than that in mainland universities. GBA International Institute for Innovation (GBAI³) of Shenzhen University can introduce high-quality entrepreneurial teachers and entrepreneurship education modes from universities in Hong Kong and Macao, and carry out academic exchanges and cooperation with the Hong Kong Polytechnic University in the form of credit transformation, double degree mechanism, joint doctoral training program, academic exchange forum and so on. Secondly, to jointly build an innovation and entrepreneurship youth community in the GBA. It can deepen the sense of identity of students in Guangdong, Hong Kong and Macao to GBAI³. Besides, it also provides them with a platform for innovation and entrepreneurship exchange, forming a unique regional culture in the GBA. Thirdly, to develop international cooperation networks. GBAI³ should grasp the strategic layout of opening up, and strengthen the utilization and cooperation of external resources by introducing foreign teachers of innovation and entrepreneurship education, jointly establishing innovation and entrepreneurship institutions, and participating in entrepreneurship practice activities and entrepreneurship competitions of international organizations.

Construction of Teaching Force for Innovation and Entrepreneurship Education

At present, since teaching activities and academic research results remain the main indicators of evaluation and promotion, practice-based projects have not been paid enough attention, resulting in a general lack of entrepreneurial practice experience among university teachers. To address that, specific suggestions are given:

Firstly, to update the system of recruitment and performance evaluation. Schools should formulate a performance evaluation system which is applicable to the teaching staff of IEE, including scientific research projects, patent results, teaching reform projects and other activities. Secondly, to optimize the teaching teams by the introduction of talents. Universities can adopt various forms including salary incentive, award of honorary title and collaborative entrepreneurship to attract talents from all fields to act as part-time teaching teachers. In addition, establish an elimination mechanism based on teaching performance in order to ensure the professionalism and effectiveness of the teaching staff for IEE. Thirdly, to improve teachers' ability regarding IEE. Universities can hold their own entrepreneurship competitions for teachers, encourage teachers to use their

personal research outcomes to participate in the competitions, and encourage students' involvement, so as to promote teaching and learning through the competitions.

Transformation of Concepts and Stimulate the Vitality of Innovation and Entrepreneurship Education

We should change the traditional concept of IEE, shift its purpose for college students from the promotion of employment to individual quality improvement of graduates. According to Bezanilla *et al.* (2020), entrepreneurship is significantly correlated to a university's mission, tactics, policies and procedures. Up to now, the IEE in universities has been focusing more on the cultivation of future independent entrepreneurs and taking the proportion of independent entrepreneurs among graduates as the evaluation index used to judge its effectiveness. However, for the students who lack entrepreneurial resources and practical experience, the number of students who are willing to start their own businesses is relatively small, which leads to the small audience of IEE in universities, and the lack of internal motivation for the reform and innovation. Therefore, universities should encourage students to establish the new concept of innovation and entrepreneurship. In the aspect of educational concept of cultivating innovative and entrepreneurial talents, the promotion of entrepreneurial awareness should be linked with students' career planning. Instead of taking choosing entrepreneurship as the starting point for IEE, students should be encouraged to face their career with entrepreneurial mentality and innovative thinking, so as to form a well prevailing custom and strong atmosphere of innovation and entrepreneurship in universities, contributing to the development of the GBA.

CONCLUSION

In the context of the development of the GBA, taking Shenzhen University as an example, this paper conducts a satisfaction survey on the students participating in the innovation and entrepreneurship training system. Through fuzzy comprehensive analysis, this paper concludes the problems in the IEE of Shenzhen University, such as scanty match between the education and practical needs, lack of substantial development, self-closure in cooperation and exchanges, insufficiency in students' awareness and so on. Additionally, it puts forward the corresponding resolutions, as well as the optimized path that other universities in the GBA can learn from, including the integration of professional education and IEE, reshaping the external cooperation mode, and strengthen the ranks of teachers and so on, so as to provide corresponding reference for the development of IEE for college students under the background of the GBA.

ACKNOWLEDGMENT

Acknowledgements. This work is partially supported by 2019 Guangdong Soft Science Project (2019A101002075), Guangdong Education Science Plan 2019 University Employment and Entrepreneurship Research Project (2019JKCY010).

REFERENCES

- [1] Bao, S. M. & Yang, D. (2016) The basic characteristics and inspirations of the development of innovation and entrepreneurship education in American colleges and universities: Taking MIT, Stanford university and Babson college as examples. *Higher Education Exploration*, 11, 62-70. (in Chinese) <https://kns.cnki.net/kcms/detail/detail.aspx?dbcode=CJFD&dbname=CJFDLAST2017&filename=GJTA201611012&v=G2vaDlcKgVvLmAT%25mmd2BEhSkgha8p0HyqjkayMFCYJakRiVsnx0SHGWaxYQxWu7AYpbO>
- [2] Bezanilla, J. M., García-Olalla, A., Paños-Castro, J. & Attruti, A. (2020). Developing the entrepreneurial university: factors of influence. *Sustainability*, 12(3), 842-858.
- [3] Cao, Z. & Mei, Z. (2018). Research on the innovation and entrepreneurship education mode in colleges and universities based on entrepreneurial ecosystem theory. *Educational Sciences: Theory & Practice*, 18(5), 1612-1619.
- [4] Castro, M.P., Scheede, C.R. & Zermeno, M.G.G. (2019). The impact of higher education on entrepreneurship and the innovation ecosystem: A case study in Mexico. *Sustainability* (Basel, Switzerland), 11(20), 5597.
- [5] Central Committee of the Communist Party of China, State Council (2019). Outline Development Plan for the Guangdong-Hong Kong-Macao Greater Bay Area. Beijing, China. (in Chinese) https://www.bayarea.gov.hk/filemanager/sc/share/pdf/Outline_Development_Plan.pdf
- [6] Chen, S. H. & Zhang, L. X. (2018) The international model, experience and reference of college students' innovation and entrepreneurship education — Based on the comparison of the United States, Germany and Japan. *Continue Education Research*, 01, 115-120. (in Chinese) <https://kns.cnki.net/kcms/detail/detail.aspx?dbcode=CJFD&dbname=CJFDLAST2018&filename=JIXE201801024&v=RHfAVvkphArr5%25mmd2F6rkldy150H6mxbZPNM66SH%25mmd2BuQbmbxRrrng5iJhfDQZ27NqmCcI>
- [7] Ding, J. Q. (2020). Inspirations from the differences between innovation and entrepreneurship education in universities at home and abroad. *Contemporary Education Research and Teaching Practice*, 2, 135-136. (in Chinese) doi: 10.16534/j.cnki.cn13-9000/g.2020.0187
- [8] Education Department of Guangdong Province (2018). Annual Report on Employment Quality of College Graduates in Guangdong Province in 2019. Guangdong Province: Department of Education. http://edu.gd.gov.cn/gtgz/bysjyzd/content/post_2137054.html
- [9] Hao, J., Wu, A. H. & Hou, Y. F. (2016) Construction and enlightenment of the innovation and entrepreneurship education system in America. *Research in Higher Education of Engineering*, 02, 7-12. (in Chinese) <https://kns.cnki.net/kcms/detail/detail.aspx?dbcode=CJFD&dbname=CJFDLAST2016&filename=GDGJ201602002&v=C6JsLRoUG0HCdiV%25mmd2BvI3rbCAFPVmZu%25mmd2BDKAmBJKN%25mmd2FpjF98UtH5pUGa9e0u2dNgd3KO>

- [10] Huang, Z. X. (2017). Transformation and development of innovation and entrepreneurship education in Chinese universities. *China Higher Education*, 7, 45-47. (in Chinese) <https://kns.cnki.net/kcms/detail/detail.aspx?dbcode=CJFD&dbname=CJFDLAST2017&filename=ZGDJ201707017&v=qUXgFTAT2Uu8fz8q4q8CTPDssvVxL6JU50fBYVB%25mmd2FbV8ftW4FTlwUf7YewZiqP4eN>
- [11] Koichi, N. & Yuko, N. (2020). The development of social entrepreneurship education in Japan. *Entrepreneurship Education*, 3 (1), 95-117.
- [12] Li, J. (2019). The promotion of collaborative and innovative development of higher education in the Guangdong-Hong Kong-Macao Greater Bay Area. *The Modern Education Journal*, 1, 11-13, 19-20. (in Chinese) <https://kns.cnki.net/kcms/detail/detail.aspx?dbcode=CJFD&dbname=CJFDLAST2019&filename=XDJY201901005&v=jUDKN3DwddOuriH216rZUUX7tHMxuCPN3vAuGDCtweI2%25mmd2BXyU98OFOCJLLLvn6>
- [13] Li, X. P., Du, X. & Sun, Y. (2019). Research on innovation and entrepreneurship education in German Universities: A case study of "Management Plus" training program in Technical University of Munich. *The Education of Innovative Talents*, 4, 83-88. (in Chinese) <https://kns.cnki.net/kcms/detail/detail.aspx?dbcode=CJFD&dbname=CJFDLAST2020&filename=CXRC201904017&v=Osiw6A58KZrQLHXr%25mmd2BvVrdntHn%25mmd2Fgx%25mmd2FdNt7kfjhnkgkPSuIb4m4vcP6Mv8k%25mmd2B13F7Ye>
- [14] Li, Y. H. (2020). The inspiration of the collaborative innovation between government, industry, universities and research institutes in the San Francisco Bay Area to the Guangdong-Hong Kong-Macao Greater Bay Area. *Journal of South China University of Technology (Social Science Edition)*, 22 (01), 1-11. (in Chinese) <https://kns.cnki.net/kcms/detail/detail.aspx?dbcode=CJFD&dbname=CJFDLAST2020&filename=HNLS202001002&v=dUcOWxsYOMwak9BQbzy3T2MDJ7F9OjQ0C9J33Sk76JL0rW0WN7Hdn9ui%25mmd2FzleSylh>
- [15] Liu, R. (2017) The characteristics and enlightenment of innovation and entrepreneurship education in American and Japanese universities. *The Party Building and Ideological Education in Schools*, 03, 94-96. (in Chinese) <https://kns.cnki.net/kcms/detail/detail.aspx?dbcode=CJFD&filename=XXDJ201703028&v=MTI3NzIUNFRYUFPMRzRIOWJNckk5SGJJUUtESDg0dII0VDZqNTRPM3pxcUJ0R0ZyQ1VSN3FIWmVsSdUZ5em1WcnI=>
- [16] Liu, Y. (2018). Research on innovation of talent cooperation and exchange system in Guangdong-Hong Kong-Macao Greater Bay area. *China Economic & Trade Herald*, 29, 26-28. (in Chinese) <https://kns.cnki.net/kcms/detail/detail.aspx?dbcode=CJFD&dbname=CJFDLAST2018&filename=JMDL201829010&v=ai1scDa5G25wehXW7ofWLjeILgevcOSyd9%25mmd2Boxp6eh0MFysWGXsGbz6WP4wqq1xR>
- [17] Rong, X. X., Wan, X. L. & Meng, Q. C. (2019). Research on the degree of satisfaction of college students toward entrepreneurship education based on fuzzy comprehensive evaluation. *Heilongjiang Researches on Higher Education*, 4, 116-120. (in Chinese) <https://kns.cnki.net/kcms/detail/detail.aspx?dbcode=CJFD&dbname=CJFDLAST2019&filename=HLJG201904024&v=uuO9hLADahYUsZ%25mmd2FRDLNSujfCGI%25mmd2BP%25mmd2BKHJ4wgDE7pF3bEvwd%25mmd2FxiEXr%25mmd2F9axnC5vA1iw>
- [18] Wang, D., Li, H. & Shao, J. T. (2017). The problems and solutions of innovation and entrepreneurship education in Chinese colleges and universities. *Heilongjiang Animal Science and Veterinary Medicine*, 18, 223-227, 234. (in Chinese) <https://kns.cnki.net/kcms/detail/detail.aspx?dbcode=CJFD&dbname=CJFDLAST2017&filename=HLJX201718085&v=ouZI6QDpqrQYOUY4eRhVscNWN80dUBk4tgaOTtTsgUE9bgEEfHhuqTJ4vcY%25mmd2BY4V>
- [19] Wang, L. Y., Wang, J. P. (2019). The present situation, predicament and countermeasures of the construction of the teaching staff of innovation and entrepreneurship education in colleges and universities. *Vocational Education Research*, 03, 49-53. (in Chinese) <https://kns.cnki.net/kcms/detail/detail.aspx?dbcode=CJFD&dbname=CJFDLAST2019&filename=JLKF201903011&v=IfXb4VpcJy4s1fy7afsNWGQ25DSyUWFy%25mmd2BPtcUGyes76W2NiMKX6BKR2Bc7pQBvMy>
- [20] Wang, X. K. (2020). Research on the path of college students' innovation and entrepreneurship education. *Open Journal of Social Sciences*, 8(3), 298-305.
- [21] Wang Y. X. & Yu Z. Q. (2020). Research on the practice mode of innovation and entrepreneurship education in universities in the Guangdong-Hong Kong-Macao Greater Bay Area. *Laboratory Research and Exploration* (07), 240-243+299. <https://kns.cnki.net/kcms/detail/detail.aspx?dbcode=CJFD&dbname=CJFDLAST2020&filename=SYSY202007054&v=veQ51yQxZgUsFab4At88EqWoecGGEgjB%25mmd2BRVnLB2DIU9v99jPsG1KKa2wPPopeFOI>
- [22] Yang, T. R. & Wu J. (2020). Institutional changes and governance requirements: the transformation and upgrading of innovation and entrepreneurship education in universities in the Guangdong-Hong Kong-Macao Greater Bay Area. *China Audio-visual Education* (8). <https://kns.cnki.net/kcms/detail/detail.aspx?dbcode=CJFD&dbname=CJFDLAST2020&filename=ZDJY202008010&v=Q9%25mmd2FZQLFYrrBIU854J7GDMpHRZIUb2jVINPan%25mmd2BKCUyQ9hcfq%25mmd2FX3zWpLbtCcPn28DA>
- [23] Yu, B. Y., Huang, H. & Wang, J. W. (2019). Inspiration from the development experience of scientific and technological talents in international bay areas to the Guangdong-Hong Kong-Macao Greater Bay Area. *Strategy for Innovation and Development of Science and Technology*, 03, 45-50. (in Chinese) <https://kns.cnki.net/kcms/detail/detail.aspx?dbcode=CJFD&dbname=CJFDLAST2019&filename=KCFZ201903007&v=0e%25mmd2BxCn6yBEMfdQTNgoOb2%25mmd2B%25mmd2FpZI6VPyEcR1JC18NSwKBHOcyyEJ2NTWCEgajW1kh0>
- [24] Yu, M. (2016) Analysis and reference of innovation and entrepreneurship education in Japanese universities. *Anhui Literature*, 05, 146-147. (in Chinese) <https://kns.cnki.net/kcms/detail/detail.aspx?dbcode=CJFD&dbname=CJFDLAST2016&filename=AHWA201605066&v=HY8HSAGpm38wojBGwEPXZRIQ60r7ORhTEmZT6kAKeHf4vN%25mmd2F%25mmd2BaDTGzO8qZG%25mmd2Bks2t>

- [25] Zeng, J. X. & Qi, F. Y. (2019). The construction of world-class universities in the Guangdong-Hong Kong-Macao Greater Bay Area with the experience of the international bay area for reference. *China Higher Education Evaluation*, 30(04), 36-47. (in Chinese) <https://kns.cnki.net/kcms/detail/detail.aspx?dbcode=CJFD&dbname=CJFDLAST2020&filename=GJPG201904007&v=NyaAKT8DHQkFzd46SM8ElaW%25mmd2FSLs9bD5HF5OkG%25mmd2Bu1XPiiIjYTyD69zghgc1HzT3z4>
- [26] Zhang H. J. & Chen J. (2019). Research on the effective path of innovation and entrepreneurship education in universities in the Guangdong-Hong Kong-Macao Greater Bay Area. *Reading Digest* (8). <https://kns.cnki.net/kcms/detail/detail.aspx?dbcode=CJFD&dbname=CJFDLASN2019&filename=DSWZ201908037&v=vL6ARBEMfeNiVMpVDpv8TeS%25mmd2FTGHDm0gv0gZX16BoXh0nbrY0kDOjAuS1MqCZi2AO>
- [27] Zhang W. N. (2014). Development of entrepreneurship education in my country's schools: Forms, problems and paths. *Educational Development Research* (03), 49-55. <https://kns.cnki.net/kcms/detail/detail.aspx?dbcode=CJFD&dbname=CJFD2014&filename=SHGJ201403012&v=NtfKdOTW2jvjBu1wr4AGN9UqMMEwaOXbuuz5PYbi5yJtTG1wvaVPSXcSiCQbu2mt>
- [28] Zhong J. H. & Yin D. M. (2020). Analysis on the realization path of innovation and entrepreneurship education in colleges and universities in the Guangdong-Hong Kong-Macao Greater Bay Area. *China Business Review*, 000(006), P.241-242. <https://kns.cnki.net/kcms/detail/detail.aspx?dbcode=CJFD&dbname=CJFDLAST2020&filename=ZGSM202006108&v=1wFayhMuEtyCbbAgYQQQ%25mmd2FuiFiff%25mmd2FbyN9c9WXjXGLYO9Oy10DypxVqy8HyHphO%25mmd2FyK>
- [29] Zhu, H. B., Zhang, K. & Ogbodo, U. S. (2017). Review on Innovation and Entrepreneurship Education in Chinese Universities during 2010-2015. *Eurasia Journal of Mathematics, Science and Technology Education*, 13(8), 5939-5948.

APPENDIX A: Cronbach Reliability Analysis

Name	Correction item total correlation (CITC)	Alpha factor with item deleted	Cronbach α coefficient
Satisfaction with compulsory courses of innovation and entrepreneurship	0.488	0.937	0.937
Satisfaction with elective courses of innovation and entrepreneurship	0.608	0.935	
Satisfaction with the form of innovative and entrepreneurial courses (MOOC, practice, etc.)	0.652	0.934	
Satisfaction with the organic combination of professional education and innovation and entrepreneurship education	0.654	0.934	
Satisfaction with the professional level of teachers in innovation and entrepreneurship courses	0.74	0.933	
Satisfaction with the source and comprehensive quality of part-time teachers in innovation and entrepreneurship education	0.678	0.934	
Satisfaction with the number allocation of teachers in innovation and entrepreneurship education	0.662	0.934	
Satisfaction with the guidance level of innovation and entrepreneurship teachers	0.78	0.932	
Satisfaction with innovation and entrepreneurship practice activities in the school	0.591	0.935	
Satisfaction with guidance and support provided by innovation and entrepreneurship associations	0.548	0.936	
Satisfaction with the construction of Students Pioneer Park in the school	0.404	0.939	
Satisfaction with practical opportunities such as research on off-campus entrepreneurship and enterprise visits	0.552	0.936	
Satisfaction with the assessment method of innovative and entrepreneurship courses	0.85	0.931	
Satisfaction with the scholarship system for innovation and entrepreneurship	0.536	0.936	
Satisfaction with institutional support for innovation and entrepreneurship	0.595	0.935	
Satisfaction with the class form of innovation and entrepreneurship courses	0.733	0.933	
Satisfaction with the functions of the Expert Steering Committee on innovation and entrepreneurship education	0.733	0.933	
Satisfaction with the construction of the school's innovation and entrepreneurship guidance platform	0.697	0.933	
Satisfaction with the publicity and guidance of School's innovation and entrepreneurship education	0.664	0.934	
Satisfaction with school's innovation and entrepreneurship exchange activities	0.689	0.933	
Standard Cronbach α coefficient: 0.941			

APPENDIX B: KMO and Bartlett's Test

KMO and Bartlett's Test		
Kaiser-Meyer-Olkin: Measure of Sampling Adequacy.		0.903
Bartlett's Test of Sphericity	Approx. Chi-Square	842.293
	df	190
	Sig.	0

APPENDIX C: Total Variance Explained

Component	Initial Eigenvalues			Extraction Sums of Squared Loadings			Rotation Sums of Squared Loadings		
	Total	% of Variance	Cumulative %	Total	% of Variance	Cumulative %	Total	% of Variance	Cumulative %
1	9.608	48.042	48.042	9.608	48.042	48.042	4.903	24.514	24.514
2	2.759	13.797	61.839	2.759	13.797	61.839	3.834	19.168	43.682
3	2.019	10.096	71.935	2.019	10.096	71.935	3.543	17.714	61.396
4	1.525	7.626	79.561	1.525	7.626	79.561	2.372	11.858	73.254
5	0.969	4.846	84.407	0.969	4.846	84.407	2.23	11.151	84.405

APPENDIX D: Evaluation Index Weight

First-level Indicators	Second-level Indicators	Weight	Factor Loading	Total Weight
Curriculum System	Satisfaction with compulsory courses of innovation and entrepreneurship	0.0132	0.121	0.1748
	Satisfaction with elective courses of innovation and entrepreneurship	0.0174	0.187	
	Satisfaction with online courses of innovation and entrepreneurship	0.0908	0.876	
	Satisfaction with the organic combination of professional education and innovation and entrepreneurship education	0.0534	0.563	
The Construction of Teaching Force	Satisfaction with the comprehensive quality of full-time teachers in innovation and entrepreneurship education	0.0594	0.459	0.3661
	Satisfaction with the source and comprehensive quality of part-time teachers in innovation and entrepreneurship education	0.1307	1.432	
	Satisfaction with the number allocation of teachers in innovation and entrepreneurship education	0.1298	1.564	
	Satisfaction with innovation and entrepreneurship teachers' temporary study in enterprises and other units	0.0462	0.545	
Practical Guidance	Satisfaction with innovation and entrepreneurship practice activities in school	0.0619	0.785	0.1917
	Satisfaction with guidance and support provided by innovation and entrepreneurship associations	0.0756	0.823	
	Satisfaction with practical opportunities such as research on off-campus entrepreneurship and enterprise visits	0.0542	0.564	
Teaching Management	Satisfaction with assessment methods of innovation and entrepreneurship courses	0.0514	0.534	0.1224
	Satisfaction with the scholarship system for innovation and entrepreneurship	0.0187	0.158	
	Satisfaction with class form of innovation and entrepreneurship courses	0.0523	0.541	
Organizational Leadership	Satisfaction with the functions of the Expert Steering Committee on innovation and entrepreneurship education	0.0598	0.598	0.1451
	Satisfaction with the construction of the school's innovation and entrepreneurship guidance platform	0.0356	0.324	
	Satisfaction with the publicity and guidance of School's innovation and entrepreneurship education	0.0497	0.432	

APPENDIX E: Descriptive Statistics of Satisfaction

First-level Indicators	Second-level Indicators	Very dissatisfied	Dissatisfied	General	Satisfied	Very satisfied
Curriculum System	Satisfaction with compulsory courses of innovation and entrepreneurship	2	9	20	63	37
	Satisfaction with elective courses of innovation and entrepreneurship	4	11	35	71	10
	Satisfaction with the form of innovation and entrepreneurship courses (MOOC, practice, etc.)	6	7	30	75	13
	Satisfaction with the organic combination of professional education and innovation and entrepreneurship education	4	9	31	67	20
The Construction of Teaching Force	Satisfaction with the professional level of teachers in innovation and entrepreneurship courses	3	8	27	88	5
	Satisfaction with the source and comprehensive quality of part-time teachers in innovation and entrepreneurship education	7	7	22	77	18
	Satisfaction with the number allocation of innovation and entrepreneurship teachers	6	8	21	79	17
	Satisfaction with the guidance level of innovation and entrepreneurship teachers	3	10	41	54	23
Practical Guidance	Satisfaction with innovation and entrepreneurship practice activities in school	5	8	11	55	52
	Satisfaction with guidance and support provided by innovation and entrepreneurship associations	4	9	29	44	45
	Satisfaction with the construction of Students Pioneer Park in the school	3	8	14	63	43
Teaching Management	Satisfaction with practical opportunities such as research on off-campus entrepreneurship and enterprise visits	4	6	25	75	21
	Satisfaction with the scholarship system for innovation and entrepreneurship	6	5	19	78	23
	Satisfaction with class form of innovation and entrepreneurship courses	5	12	29	50	35
Organizational Leadership	Satisfaction with the functions of the Expert Steering Committee on innovation and entrepreneurship education	4	9	49	52	17
	Satisfaction with the construction of the school's innovation and entrepreneurship guidance platform	7	8	47	44	25
	Satisfaction with the publicity and guidance of School's innovation and entrepreneurship education	6	9	11	89	16

APPENDIX F: Questionnaire of Shenzhen University Students' Satisfaction on Innovation and Entrepreneurship Education

Hello! The main purpose of this survey is to understand the current situation of IEE in Shenzhen University and the suggestions and opinions of students on the current IEE in Shenzhen University under the background of the Guangdong-Hong Kong-Macao GBA, so as to provide scientific and feasible references for the improvement of IEE in Shenzhen University and even other universities in Guangdong-Hong Kong-Macao region. Thank you for your support and cooperation!

Fill in the Blanks

Sex		College	
Major		Grade	

Scale

Title number	Title	1	2	3	4	5
1	Satisfaction with compulsory courses of innovation and entrepreneurship	Very dissatisfied	Dissatisfied	General	Satisfied	Very satisfied
2	Satisfaction with elective courses of innovation and entrepreneurship	Very dissatisfied	Dissatisfied	General	Satisfied	Very satisfied
3	Satisfaction with the form of innovation and entrepreneurship courses (MOOC, practice, etc.)	Very dissatisfied	Dissatisfied	General	Satisfied	Very satisfied
4	Satisfaction with the organic combination of professional education and innovation and entrepreneurship education	Very dissatisfied	Dissatisfied	General	Satisfied	Very satisfied
5	Satisfaction with the professional level of teachers in innovation and entrepreneurship courses	Very dissatisfied	Dissatisfied	General	Satisfied	Very satisfied
6	Satisfaction with the source and comprehensive quality of part-time teachers in innovation and entrepreneurship education	Very dissatisfied	Dissatisfied	General	Satisfied	Very satisfied
7	Satisfaction with the number allocation of teachers in innovation and entrepreneurship education	Very dissatisfied	Dissatisfied	General	Satisfied	Very satisfied
8	Satisfaction with the guidance level of innovation and entrepreneurship teachers	Very dissatisfied	Dissatisfied	General	Satisfied	Very satisfied
9	Satisfaction with innovation and entrepreneurship practice activities in school	Very dissatisfied	Dissatisfied	General	Satisfied	Very satisfied
10	Satisfaction with guidance and support provided by innovation and entrepreneurship associations	Very dissatisfied	Dissatisfied	General	Satisfied	Very satisfied
11	Satisfaction with the construction of Students Pioneer Park in the school	Very dissatisfied	Dissatisfied	General	Satisfied	Very satisfied
12	Satisfaction with practical opportunities such as research on off-campus entrepreneurship and enterprise visits	Very dissatisfied	Dissatisfied	General	Satisfied	Very satisfied
13	Satisfaction with assessment methods of innovation and entrepreneurship courses	Very dissatisfied	Dissatisfied	General	Satisfied	Very satisfied
14	Satisfaction with the scholarship system for innovation and entrepreneurship	Very dissatisfied	Dissatisfied	General	Satisfied	Very satisfied
15	Satisfaction with institutional support for innovation and entrepreneurship	Very dissatisfied	Dissatisfied	General	Satisfied	Very satisfied
16	Satisfaction with class form of innovation and entrepreneurship courses	Very dissatisfied	Dissatisfied	General	Satisfied	Very satisfied
17	Satisfaction with the functions of the Expert Steering Committee on innovation and entrepreneurship education	Very dissatisfied	Dissatisfied	General	Satisfied	Very satisfied
18	Satisfaction with the construction of the school's innovation and entrepreneurship guidance platform	Very dissatisfied	Dissatisfied	General	Satisfied	Very satisfied
19	Satisfaction with the publicity and guidance of School's innovation and entrepreneurship education	Very dissatisfied	Dissatisfied	General	Satisfied	Very satisfied
20	Satisfaction with school's innovation and entrepreneurship exchange activities	Very dissatisfied	Dissatisfied	General	Satisfied	Very satisfied

Guidance in the Network Jungle - A Typology of Inter-Company Innovation Networks

(Full Paper)

Johannes Trenkle, Technical University of Munich, Munich, Germany, j.trenkle@tum.de
Carl-Philipp Beichert*, Technical University of Munich, Munich, Germany, c.beichert@tum.de

ABSTRACT

Inter-organizational networks are recognized as a collaborative means of enabling small and medium-sized enterprises to compete and innovate in a dynamic environment. Previous studies have analyzed network types and their characteristics, yet there is no empirically grounded network typology combining and integrating these lone-standing attributes from either an academic or a practitioner-oriented point of view. By applying an explorative, sequential, mixed methodology approach, we provide the first typology of innovation networks based on both previous theories and newly generated empirical data. We conduct a directed content analysis to compile a comprehensive data set and apply a hierarchical, agglomerative clustering approach using the Ward linking method. We contribute to existing academic network research by providing the first compelling, generic typology of inter-organizational innovation networks and thereby offer guidance to practitioners and policy makers in the jungle of word creations around innovation networks. We identify and describe 11 types of formal inter-organizational innovation networks: Avid Persuaders, Value Chain Drivers, Collective Facilitators, Niche Specialists, Lateral Thinkers, Transnational Opportunity Seekers, Financially Resilient Connectors, Local Trend Sponsors, Regional Activists, Associated Industry Supporters, and Dynamic Research Groups.

Keywords: Inter-organizational networks; innovation networks; SME; cluster analysis

*Corresponding author

INTRODUCTION

Digitalization and fast-paced company environments are increasing the competitive pressure on companies (BMW, 2018). In order to succeed, companies aim to include collaborative activities in their innovation strategies, thereby executing a change in paradigms as companies and organizations transform their innovation processes from privately conducted research to collaborative behavior, from closed to open innovation (Chesbrough, 2003). Within this change, engagement in innovation networks increases, which plays a crucial role in innovation strategies for almost all kinds of companies. The firms seek collaboration through networks to overcome limited resources as well as to share risks incorporated in research and development (R&D) activities (Sydow, 2001).

Networks are of particular relevance to small and medium-sized enterprises (SMEs). SMEs are bound by limited financial as well as human resources in seeking innovation (Mieke, 2008). Other than large enterprises, SMEs do not have a regular exchange with partners from science or engage in common R&D partnerships (Rammer, Gottschalk, Peters, Bersch, & Erdsiek, 2016). Therefore, networks and collaborative activities are recognized as playing a crucial role in enabling SMEs to compete and innovate in a dynamic environment (Valkokari & Helander, 2007). Nevertheless, the participation of SMEs in innovation networks is still significantly lower than for large companies (BMW, 2018; Buhl, Sedlmayr, & Meier, 2019; Mieke, 2008; Rammer *et al.*, 2016). In order to support SMEs in their collaboration efforts, policy makers aim to further promote the engagement of SMEs in innovation networks. Therefore, it is of interest which innovation networks are available for SMEs to promote these networks in a directed manner and to offer companies guidance when defining an innovation strategy.

Previous literature has identified a variety of network types based on different, non-consistent sets of characteristics, including direction of collaboration (e.g. Hagenhoff, 2008; Killich, 2011; Morschett, 2003; Payer, 2008), geographical orientation (e.g. Killich, 2011; Morschett, 2003; Payer, 2008), the intensity of collaboration (Killich, 2011), the commitment of the involved parties (Hagenhoff, 2008; Killich, 2011), duration (e.g. Hagenhoff, 2008; Killich, 2011; Morschett, 2003), goal identity among actors (Killich, 2011), and departments or functions involved (e.g. Hagenhoff, 2008; Killich, 2011). Thus, existing studies are either bound to common limitations of qualitative studies, especially the lack of generalizability, or suffer from a limited range of network characteristics they take into account. This has led to the emergence of various network typologies (see, e.g., Provan & Kenis (2008), Inkpen & Tsang (2005), Cooke *et al.* (1997), Bau *et al.* (2014)), which are especially lacking in their underlying empirical database. To address this gap in the literature, we combine previously identified, lone-standing characteristics and attributes of networks to create a comprehensive typology for formal inter-organizational innovation networks. We ask: What are the predominant types of formal inter-organizational innovation networks and how can they be characterized?

To address this question, we apply an exploratory, sequential, mixed method approach. We conduct a directed content analysis using a framework of network characteristics and attributes derived from previous research to compile a comprehensive data set of innovation networks. Subsequently, we apply hierarchical agglomerative clustering (HAC), building on similarities and differences across the identified network attributes. As a result, we observe 11 general types of networks with distinctive characteristics that constitute our typology of formal inter-organizational innovation networks. We compare our typology with previously existing literature and identify potential research directions for further analysis.

The remainder of this study is structured as follows. In section 2, we give an overview of the research background, deriving the study's relevance from potential benefits that SMEs can realize from collaboration within network integration, and give an overview on formal networks and related typologies. Section 3 shows our sample and data construction and introduces our sequential use of qualitative content analysis and quantitative clustering. Section 4 introduces and describes our 11 network types, which we discuss in section 5. Section 6 concludes the study, explicates implications as well as limitations, and sheds light on avenues for further research.

BACKGROUND

The theoretical background sheds light on the broad area of networks and educates the reader on previous research. We outline the need for collaboration for SMEs and their motivation to join network solutions. We provide an overview of the variety of existing studies targeting network typologies and characteristics and identify the need for an empirically grounded network model. We further define our research focus by giving a definition of formal inter-organizational innovation networks and formulate our research question.

SMEs' benefits from collaboration and network integration

SMEs show great innovation capabilities and quality, as they strive to gain competitive advantages through innovative products, manufacturing technologies, and services. The development of such innovations ties up considerable resources and requires special know-how, both being limited factors especially in SMEs (Mieke, 2008). Furthermore, SMEs have significant limitations in terms of their ability to internationalize, innovate, and cope with competitive and environmental pressures (Agostini & Nosella, 2019). At the same time, the competitive pressure on SMEs is increasing nowadays, boosted by the development of digital technologies. As an example, the share of implemented digital processes is comparatively lower for SMEs than for large companies (BMW, 2018). The era of digitization forces companies more than ever to develop and implement new processes and products or to adapt their business models to changing market environments.

In order to meet future challenges, a high degree of innovation orientation of SMEs in Germany is reflected in their business strategies. A large proportion of German SMEs, however, carry out technological innovation activities without internal R&D activities, particularly because of barriers that have recently arisen in terms of high economic risks, innovation costs, and lack of financial resources (Rammer *et al.*, 2016). This can be regarded as an indicator of a great need to access external know-how (Mieke, 2008). Barriers can be overcome by collaborative activities and networks, as they can reduce the need for capital as well as the strategic risk (Sydow, 2001). Collaborative activities and networks are suitable for SMEs to compete and innovate in dynamic business environments (Valkokari & Helander, 2007). Policy makers are already taking the need for collaboration into account by offering public funding and various support programs to promote engagement in networks (Rammer *et al.*, 2016). The promotions target the technology transfer at the interface of industry and research with a special focus on the integration of SMEs into initiative programs (BMW, 2020). Technology-open promotions and support programs are intended to strengthen and expand competitiveness, networking, innovative strength, and employment among SMEs (Buhl, Sedlmayr, & Meier, 2019).

Formal inter-organizational innovation networks

In contrast to simple forms of dyadic collaboration, a network is generally characterized by complex relationships between several entities involved. Owing to the broad, cross-disciplinary use of terms referring to networks, such as collaboration, network, and cluster, various definitions exist for networks. Within the heterogeneous spectrum of definitions, many terms are used differently depending on the individual definition of the author (Frieze, 1998). Therefore, it is crucial to first define the scope of networks under analysis in this study.

Participation in a network reflects a strategic decision by organizations seeking to exchange resources and gain a competitive advantage that they could not obtain alone (Child, Faulkner, & Tallman, 2005; Sydow, 2001; Wissema & Euser, 1991). Previous research discusses different approaches and theories dealing with the motivation, emergence, and processes of networks, resulting in two commonly accepted approaches (Casals, 2011). The Transaction Cost approach explains collaboration with the aim of minimizing costs, whereas the Resource Based View explains collaboration as the bundling of resources (Williamson, 1981). As internal resources are limited, the Resource Based View approach suggests that, in order to exploit all existing resources and to develop a long-term competitive advantage, firms need to access external knowledge (e.g. Williamson, 1981). To reduce the uncertainty of resource availability, organizations can either acquire them or access them through collaboration (Sydow, 1992). Access through collaborative activities and networks offers the opportunity to increase strategic flexibility and, furthermore, to reduce capital requirements. In contrast, the resulting risks include a loss of strategic autonomy and a potential increase in coordination costs (Sydow, 2001).

Different types of collaboration and networks are hybrid forms of coordinating economic activities between the two established paradigms of market and hierarchy. Networks combine market and hierarchical, competitive and collaborative elements (Sydow, 1992). In contrast, Powell (1990) claimed that networks have to be seen as an independent form of coordination besides the forms of market and hierarchy. As this assumption would imply that only one general form of networks exists, other studies disprove this view and suggest network typologies to differentiate forms of collaboration accounted for as networks (Provan, Fish, & Sydow, 2007; Provan & Kenis, 2008). As all forms of collaboration and networks share different market- and hierarchical-oriented characteristics, we consider that different types of networks can be positioned within the spectrum of market and hierarchy, influencing, e.g., network governance (Friese, 1998; Sydow, 1992). This, furthermore, implies that networks can “produce positive outcomes that would not be possible in a market or a hierarchy” (Provan & Kenis, 2008, p. 5), fostering beneficial expectations for network engagement among SMEs.

Networks are an organizational form of economic activity aimed at realizing competitive advantages that are characterized by complex reciprocal, collaborative rather than competitive and relatively stable relationships, whereas involved entities are legally independent, but economically mostly dependent enterprises and organizations (Sydow, 1992). Reciprocal behavior suggests that social exchange always leads to an immediate or later counter-exchange; however, the motivation is based on a social norm rather than on a contract (Gouldner, 1960). As collaboration can exist between two entities, networks consist of multiple organizations linked through multilateral ties that result in a group of three or more organizations. The connections are created in order to facilitate the achievement of a common goal (Provan *et al.*, 2007) that can vary, e.g., from access to new or complementary knowledge, marketing, the increase in economies of scale, and risk sharing (Mariti & Smiley, 1983). Members of a network usually aim for a combination of different objectives (Morschett, 2003). Provan, Fish, & Sydow, 2007, distinguish inter-organizational and intra-organizational networks. For this study, we only consider inter-organizational networks of at least three organizations interacting across their organizational boundaries (Provan *et al.*, 2007). Networks can emerge between organizations resulting from business transactions without being created by any kind of authority. These networks are described as informal networks, but lack visibility and publicly available data (Cross, Nohria, & Parker, 2002). On the other hand, networks can be created and managed by either a hierarchical or a heterarchical structure (Sydow, 2001). Networks are established by collaborative actions and fixed by an explicit collaboration agreement (Van Aken & Weggeman, 2000). In order to ensure consistent data availability, we limit our study to formalized networks.

Especially in R&D, which is assumed to play a crucial role in the value creation process and can determine the competitiveness of companies, collaborations can lever product innovation and market success of new products (Hottenrott & Lopes-Bento, 2016). Collaboration is therefore usually determined by a combination of the different skills and knowledge bases of the partners involved. Collaborative networks are the most significant source of innovation that leverage resources and capabilities across multiple organizations (Schilling, 2013). Networks offer vast opportunities, e.g., to enhance the use of tacit specialist knowledge, overall competence exchange, and dynamic technological innovation (Powell, 1990). Innovation networks are characterized by organizations that are engaged in product, process, or service innovation (Van Aken & Weggeman, 2000). For this study, we include networks in which organizations or departments of companies are involved that focus on R&D projects. We do not limit our focus to inter-firm R&D partnerships (Hagedoorn, 2002), but rather regard networks consisting of different organizations that share research or development activities toward their common objectives.

In order to narrow our research focus, we determine a working definition of formal inter-organizational innovation networks based on the previously presented literature and research: *Formal inter-organizational innovation networks are multiple legally independent organizations linked through multilateral ties in order to achieve common process, product, or service innovation. The linkages and activities between the organizations are aligned and coordinated by a management, organization, or authority.*

Particularly occurring in high-technology sectors, collaboration is often facilitated by geographical proximity, which can lead to regional technology clusters (Schilling, 2013). The interaction between firms tends to be more intense when they share some type of similarity, such as geographical or technological proximity (Schilling & Phelps, 2007). Regional knowledge networks of related organizations are often referred to as “clusters” (Vieregge, 2011). This term was coined by Porter (1998, p.78), who defined clusters as “(...) geographic concentrations of interconnected companies and institutions in a particular field.” Clusters can consist of competitors, suppliers, customers, and other entities such as governmental organizations, research institutes, universities, and trade associations (Porter, 1998). In contrast to clusters as local agglomerations, formal networks are not necessarily linked to specific locations and are actively controlled by an authority or management. However, for the purpose of this study, our definition includes clusters that also share the characteristics of formal inter-organizational networks with strong regional ties.

Typologies of networks

Even though some preliminary literature on inter-organizational networks exists, yet no consistent typology of networks grounded in empirical data is established. Existing analyses based on qualitative methodologies such as case studies and semi-structured interviews from company perspectives are limited in their ability for generalization (see, e.g., Bau, Bentivegna, & Forster, 2014). Still, academic predecessors provide a number of network typologies and give a broad selection of distinctive network characteristics, able to distinguish between networks (Payer, 2008). As definitions of network types are often based on their characteristics, previously identified network types can differ significantly and lack comparability. Some are defined

based on one specific key characteristic, and others refer to a set of selected characteristics. A proposed morphological box of collaboration characteristics by Killich (2011) summarizes common characteristics in Figure 1, independent of the type of collaborative activities. Within the morphological box, a variety of different features of the respective characteristics are suggested.

Characteristic	Features					
Direction	Horizontal		Vertical		Lateral	
Geographical extension	Local	Regional		National		Global
Intensity	Low		Moderate		High	
Commitment	Agreement		Contract		Capital commitment	
Duration	Temporary			Unlimited		
Goal identity	Redistributive			Reciprocal		
Collaborative departments	R&D	Sales	Procurement	Marketing	Production	Other

Figure 1: Morphological box of collaboration characteristics, based on Killich (2011, p. 18).

The direction indicates the value creation stage at which collaboration partners operate. Horizontal collaboration is conducted between partners at the same stage, whereas vertical collaboration includes partners from different stages in the value chain. Lateral collaboration can include partners from different value chains as well (e.g., Hagenhoff, 2008; Killich, 2011; Morschett, 2003; Payer, 2008). Geographical activities of collaboration can be distinguished between very locally concentrated up to global spanning collaboration (e.g. Killich, 2011; Morschett, 2003; Payer, 2008). The intensity of collaboration describes the degree to which activities need to be coordinated with partners (Killich, 2011). Another key characteristic is the commitment, which can extend from loose agreements up to signed contracts or monetary investments (e.g. Hagenhoff, 2008; Killich, 2011). Therefore, the duration is also often regarded, but is only distinguished between temporary and unlimited time horizons (e.g. Hagenhoff, 2008; Killich, 2011; Morschett, 2003). A crucial characteristic for collaboration is the goal identity, which describes the benefit the actors aim to achieve. A distinction is made between the pooling of resources with the same intention, a redistributive goal identity, and an exchange of services to achieve individual but complementary goals, namely reciprocal goal identity (Killich, 2011). Additionally, collaboration can be characterized by the departments or functions actively involved (e.g. Hagenhoff, 2008; Killich, 2011).

Academically identified characteristics are complemented by additional network characteristics and typologies. Although typologies should ideally be free of overlaps, previous research indicates that transitions between network types are often fluent and not precisely determinable (Schuh *et al.*, 2011). Sydow (2001) has already described the opportunities for creating typologies of inter-organizational networks as infinite and provides a list of 26 different possibilities to distinguish network types based on their characteristics. A review of empirical research about inter-organizational networks by Provan, Fish, & Sydow (2007) has already identified a general focus on network governance and network structure. Following on from this, Provan & Kenis (2008) differentiate networks according to their form of governance, resulting in three types of networks: Participant-Governed Networks, Lead Organization-Governed Networks, and Network Administrative Organization. Network types are further determined based on their structure, as some are dominated by a focal organization and others have polycentric structures (e.g. Child *et al.*, 2005; Sydow, 2001). Sydow (2001) suggests a typology of networks based on the type of control (hierarchical—heterarchical) and the stability of relationships (stable—dynamic) and derives four types: Strategic Networks, Regional Networks, Project Networks, and Virtual Undertakings. Networks are also observed regarding the positioning of the actors in the value chain. A commonly identified network type is the collaboration of partners with a vertical relationship in the value chain, referred to as vertical integration or vertical partnerships (e.g. Bau *et al.*, 2014; Dussauge & Garrette, 1999; Sydow, 2001). As local agglomerations are associated with networks, previous studies also described networks by their local and regional focus (e.g. Inkpen & Tsang, 2005; Payer, 2008; Porter, 1998; Sydow, 2001, 2010). Cooke, Gomez Uranga, & Etxebarria (1997) established the theory of Regional Innovation Systems. Regarding innovation, networks have been observed in terms of their purpose and the common objectives of their actors. A series of previous studies identified several different network types that aim to foster innovation among their actors (e.g. Bau *et al.*, 2014; Lyytinen *et al.*, 2016; Priestley & Samaddar, 2007; Wissema & Euser, 1991). To mention one example that is directing our analysis, Bau, Bentivegna, & Forster (2014) conducted a quantitative analysis of network characteristics to identify types of informal innovation networks. However, as they collected secondary data from semi-structured interviews with company representatives, their typology solely reflects the company perspective. Based on a consecutive cluster analysis, a typology of five innovation network types with their corresponding characteristics is suggested: Knowledge and Learning, Financial Procurement, Vertical Integration, International Scope, and Isolate Islands.

To summarize, the existing literature provides a large selection of network characteristics to describe and differentiate possible network types. This results in a wide variety of independent network typologies. Provan *et al.* (2007) have already proposed the combination of previously gained insights with an analysis at a network level. They formulated the need to study inter-organizational networks using a qualitative and quantitative approach. Yet a considerable number of qualitative studies contribute to the area of network types and characteristics, whereas only a few conducted a mixed method approach to structure previous insights and provide a framework. In an attempt to build a comprehensive framework based on a mixed method approach, e.g., Bau *et al.* (2014) used secondary data from a multiple case study and conducted a quantitative cluster analysis in order to generate their typology. Comparably, existing typologies are based on the derivation of individually

conceptualized matrices that consist only of selected network features from theory. Thus, existing typologies are difficult to compare and are not comprehensively grounded in empirical data. As reflected by Provan *et al.*, (2007), this represents only individual perspectives on networks, yet the existing literature does not provide a comprehensive generalizable classification.

Therefore, we recognize a need to combine previously identified, lone-standing network types and attributes into a comprehensive typology with a solid empirical foundation. Taking into account network characteristics and attributes from existing literature, we aim to identify and analyze types of formal inter-organizational innovation networks in order to derive a comprehensible, generally applicable typology, thereby answering the question: *What are the predominant types of formal inter-organizational innovation networks and how can they be characterized?*

RESEARCH DESIGN, SAMPLE, AND METHODS

Research design

We conduct a qualitative content analysis followed by a quantitative cluster analysis, inspired by previous research about innovation networks by Bau *et al.* (2014), the applied clustering approach of Delgado, Porter, & Stern (2016), and the applied mixed method approach of Täuscher & Laudien (2018). Our methodology represents an exploratory sequential mixed method approach (Creswell, 2014). We first use directed content analysis to compile a comprehensive data set (Hsieh & Shannon, 2005). Subsequently, we apply a hierarchical clustering approach using Ward's linkage method to cluster the results from our content analysis (Ward, 1963). In the following section, we describe our sampling procedure and applied methods.

Sample

In order to identify networks in a structured manner, we use a large online listing of networks provided by "Clusterplattform Deutschland" (BMWi, 2020). This guarantees a structured sampling procedure as well as networks of sufficient quality. The term cluster can be misleading, as the focus of the platform is not limited to clusters in a narrow sense. The listed networks on the platform, so-called cluster initiatives, are supported by funding programs to foster the development of cluster and network structures. The networks are subject to the assumption that the actors involved are key players in the innovation process and thus make a decisive contribution to innovation and value creation (Buhl *et al.*, 2019).

As we generate our sample data, all entries from the online listing of "Clusterplattform Deutschland" are retrieved, resulting in a list of 463 networks. Within a first screening process, the entries are tested in terms of consistency with our previously formulated definition of formal inter-organizational innovation networks. Following this, some identified networks do not match our definition and are excluded from the sample. Furthermore, several entries are removed, as they either do not provide sufficient information to fulfill the purpose of a content analysis or represent duplicates. After this process, our sample consists of 300 formal inter-organizational innovation networks.

The resulting sample of networks shows the following characteristics. As we retrieve the networks from a German online listing, the sample is geographically limited. Besides, no further limitations are made regarding the networks' locations across Germany as well as the age or size of the networks. A distribution across the 16 federal states of Germany can be observed, as presented in Figure 2. A few states, namely Baden-Wuerttemberg and Lower Saxony ("Niedersachsen") are represented with more networks in our sample, but we did not include aspects of representativeness in our analysis. This issue is not solely present in our final sample, but also reflects the initial distribution of networks on "Clusterplattform Deutschland" (BMWi, 2020) before our exclusions.

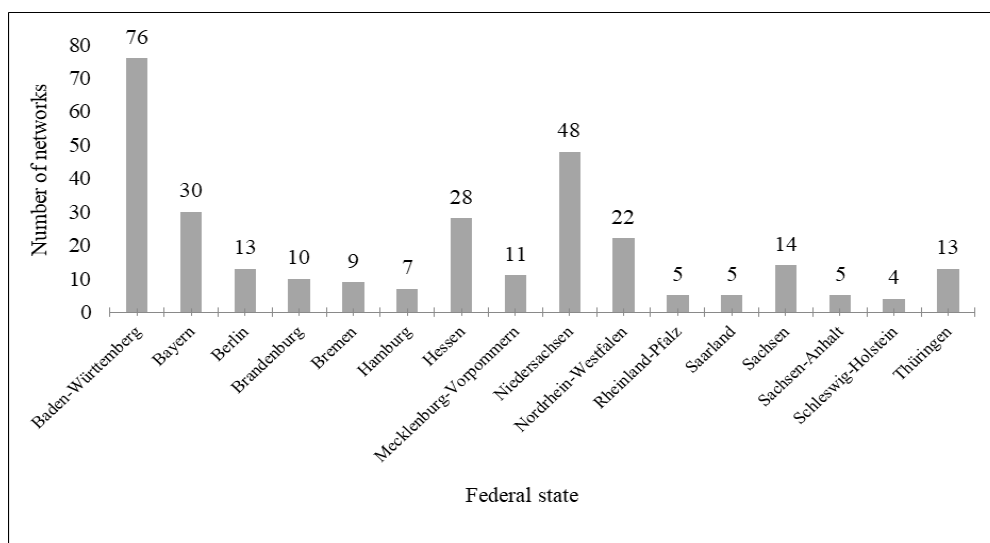

Figure 2: Distribution of analyzed networks by federal state.

We use the number of actors involved in a network to describe the size of the networks. No information or an exact number of actors could be found for 26 networks, marked as N/A in Figure 3. As illustrated, most of the networks range between 10 and 100 actors. Only very few networks consist of less than 10 or more than 500 actors.

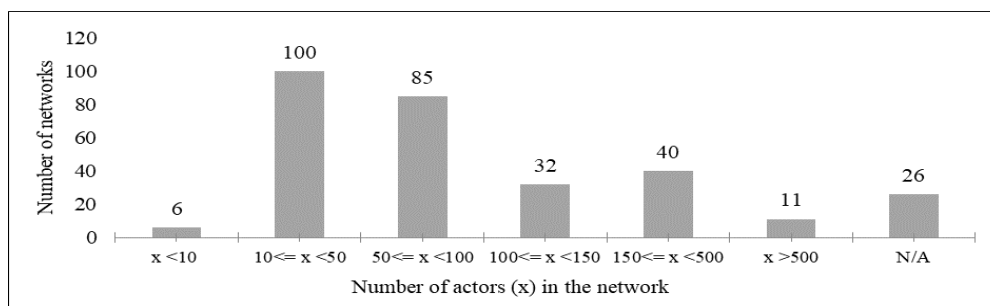

Figure 3: Distribution of analyzed networks by size (number of actors).

Qualitative content analysis

In order to generate a comprehensive data set, we conduct a qualitative content analysis using a directed approach. The purpose of this content analysis is to translate qualitative information into numerical data, which can be analyzed consecutively using a quantitative method (Potter & Levine-Donnerstein, 1999).

For a directed content analysis, codes are first derived from theory and relevant research findings and are adapted during the analysis (Hsieh & Shannon, 2005). We first consider a selection of network and collaboration characteristics based on previous literature as initial coding categories (Potter & Levine-Donnerstein, 1999). The coding process is conducted based on publicly available information on the websites of the identified networks, complemented by information provided by “Clusterplattform Deutschland” (BMW, 2020). The set of characteristics and features is continuously adapted during this process (Hsieh & Shannon, 2005). An overview of our initial set of characteristics is given in Appendix 4.1. Characteristics that appear to be less appropriate, difficult to interpret, or that can only be determined based on highly subjective assessments are removed from the data set. Furthermore, characteristics must be removed if sufficient information cannot be retrieved from publicly available sources.

The final set of characteristics we take into account for the quantitative cluster analysis covers a wide range of potential factors, able to explain differentiated types of networks. Origin explains whether the network is created top-down by one or more entities or emerged through the relationships of several organizations. Control captures the expected weighting of management influence among the partners in the network, i.e., whether a network is managed via a focal company or controlled by several entities. Governance, in contrast, describes the stringency of administration throughout the network and in relation to the partners involved. Network identity evaluates the objectives of the network and its members. Geographical extent covers the geographical range of the network. The positioning of actors in the value chain describes the relationship of the network partners with regard to their process of value creation. Commitment depicts the binding nature by which network partners enter to become network members, i.e., an agreement, a contract, or even an equity contribution. Initiators of the network include a range of organizations that kick-off and thereby initiate networks. Actors in the network, on the other hand, can be companies, scientific institutions, and others at an appropriate level of explanation depth. Further single features target special foci such as a special industry, start-ups, physical premises, lobbying, and technology. The final characteristics and features of the sample are presented in Table 1 together with the corresponding description.

Table 1: Definition of network characteristics for survey during the directed content analysis.

Characteristic	Feature	Description
Origin	Top-down	The network is either created top-down by one or more entities or
	Bottom-up	emerged through the relationships of several organizations.
Control	Hierarchical	Hierarchically managed networks are characterized by the existence of a focal company.
	Heterarchical	Heterarchical networks are controlled by several entities.
Governance	Lead organization	A focal organization is leading the network or is determining the management.
	Network administration	An independent management is set up to manage and control the network.
	Shared	Decentralized and joint coordination by many or all members.
Network identity	Reciprocal	Equalization of one's own weaknesses through the strengths of complementary capabilities from partners.
	Redistributive	Equalization of common weaknesses through the bundling of resources.
Geographical extent	Local	The network activities are concentrated in one city.
	Regional	The network focus is set on one region.
	State	The network activities concentrate within a federal state.
	National	The network activities are nationwide.
Positioning of actors in the value chain	International	The network activities are across national borders.
	Horizontal	The actors are positioned at the same stage within the same value chain.
	Vertical	The network includes actors in upstream and downstream stages of the value chain.
Commitment	Lateral	Actors from different value chains and stages are involved.
	Arrangement	Loose collaboration based on verbal agreements.
	Contract	The membership of a network requires the signing of a contract.
Initiators of the network	Equity	The membership of a network requires a monetary investment.
	University/R&D institutes	Research institutes or universities are among the initiators.
	Association	Associations are among the initiators.
	Company	Companies are among the initiators.
	Chamber	Chambers are among the initiators.
	Network	Another (established) network is among the initiators.
	Local development organization	A local development organization is among the initiators.
Actors in the network	Public institution	A public institution is among the initiators.
	Companies	Companies are active in the network.
	Universities/R&D institutes	Universities or research institutes are active in the network.
Single features	Other	Other organizations, not further specified, are active in the network.
	Industry focus	The common objectives of the network target an industry.
	Start-up support	The network interacts with start-ups.
	Common premises	The network offers common premises, such as co-working spaces or think labs.
	Lobbying	The network actively engages in lobbying activities for its actors.
	Technology focus	The network focuses on the development of a specific technology.

The preselected characteristics are transferred into binary variables to assess whether a network fulfills a feature or not. During the coding process, a "1" is assigned for each existing feature and a "0" for every feature that is not fulfilled by an observed network. In order to reduce elements of subjective interpretations during the coding process, the coding of qualitative information is partially counter-tested vice versa by the authors.

Quantitative cluster analysis

We apply a quantitative cluster analysis to identify groups of networks with similar features in the previously generated binary data set (Backhaus, Erichson, Plinke, & Weiber, 2018). Before conducting a cluster analysis, crucial decisions regarding the measure of proximity, clustering method, and number of clusters are made. Before all this, the sample variables must be prepared to guarantee interpretable results (Everitt, Landau, Leese, & Stahl, 2011).

First, each feature is assigned to a cluster variable for the cluster analysis. As the cluster variables represent the network characteristics and features, we ensure that the variables are of sufficient quality. We conduct a frequency analysis to identify characteristics that occur rarely. They are considered less appropriate for the cluster analysis and are removed. Not all variables within the same characteristic sum up to 100% as multiple feature selection is considered for certain characteristics. Moreover, variables indicating a doubled characteristic are omitted. Variables representing a feature of a hybrid characteristic are merged. Thus, for a hybrid characteristic, a “1” can represent the first feature and a “0” represents the second. The merged variables are listed in Table 2. This modification reduces the number of variables from 35 to 32.

Table 2: Merged cluster variables

Characteristic	Original variable	Original feature	Merged variable	Merged feature
Origin	C_orig_topdown	Top-down	C_origin	1 = Top-down
	C_orig_bottomup	Bottom-up		0 = Bottom-up
Control	C_control_hier	Hierarchical	C_control	1 = Hierarchical
	C_control_heter	Heterarchical		0 = Heterarchical
Network identity	C_ident_reciproc	Reciprocal	C_identity	1 = Reciprocal
	C_ident_redistr	Redistributive		0 = Redistributive

Highly correlated cluster variables lead to an overrepresentation of the underlying aspects as they provide redundant information. In order to guarantee a high quality of cluster variables, we conduct a correlation analysis of the 32 remaining variables, where we classify a correlation coefficient above 0.9 as critical. No critical correlation was observed between the sample variables; therefore, our final set of characteristics for analysis consists of 32 variables, which are shown in Table 3.

We apply hierarchical agglomerative clustering (HAC) methods, as they appear to be most suitable for our research purpose (Bau *et al.*, 2014; Delgado *et al.*, 2016; Täuscher & Laudien, 2018). HAC offers the advantage that it provides cluster solutions, but can also be used to determine the optimal number of clusters (Kassambara, 2017). In order to conduct a structured cluster analysis, we follow the approach suggested by Backhaus *et al.* (2016), which contains three steps. At first, a proximity measure is chosen, which is required for the selection of the cluster method that represents the clustering algorithm. Finally, the optimal number of clusters is determined to conduct the cluster analysis.

Therefore, we first select a distance measure and linkage method that determines how the algorithm combines the objects in our data set into clusters. The selection of a suitable method is of the utmost importance as the results can vary on the same data (Everitt *et al.*, 2011). For the comparison of absolute data, it is suggested to use a distance measure instead of similarity measures as a proximity measure (Backhaus *et al.*, 2018). We apply Ward.D2 as a linkage method in combination with the Euclidean distance as both aim to maximize the homogeneity within the clusters and generate clusters that are as different as possible from one another (Backhaus *et al.*, 2018; Ward, 1963). This is a crucial characteristic of the underlying algorithm, as we aim to achieve more easily interpretable results. Network types are generally assumed to have fluent transitions and are therefore difficult to distinguish (Schuh *et al.*, 2011). The third step in the cluster analysis represents the determination of the optimal number of clusters, referred to as k . As the determination of k has a great impact on the final cluster solution, we apply various methods to indicate an optimal k ; as yet there is no optimal method suggested in the literature. We apply an indicator method by Han, Kamber, & Pei (2012), and compare this number with the Elbow Method, Silhouette Method, and Gap Statistic Method (e.g. Everitt *et al.*, 2011; Kassambara, 2017). Based on the results of the conducted methods, we consider $k=11$ as an optimal number of clusters for the following analysis. After determining the optimal number of clusters, we conduct a hierarchical agglomerative clustering analysis. The cluster analysis is performed using the Ward.D2 method as the algorithm to combine objects into clusters based on the generated Euclidean distance matrix (Ward, 1963). We use the programming language R to perform the cluster analysis. Following the cluster analysis, we review each group of networks in terms of their characteristics and features in order to identify distinctive characteristics for each cluster. Therefore, the frequencies of the cluster variables are calculated within each cluster. Through an iterative process, followed by a profound discussion between the authors, we define network types by choosing concise and appropriate names to reflect the networks in the respective clusters.

Table 1: Final set of cluster variables

Characteristic	Variable	Feature
Origin	C_origin	1 = Top-down 0 = Bottom-up
Control	C_control	1 = Hierarchical 0 = Heterarchical
Governance	C_gov_lead	Lead organization
	C_gov_admin	Network administration
	C_gov_shared	Shared
Network identity	C_identity	1 = Reciprocal 0 = Redistributive
Geographical extent	C_geo_local	Local
	C_geo_regio	Regional
	C_geo_state	State
	C_geo_natio	National
	C_geo_intern	International
Positioning of actors in the value chain	C_vchain_horiz	Horizontal
	C_vchain_vertic	Vertical
	C_vchain_lat	Lateral
Commitment	C_commit_arrange	Arrangement
	C_commit_contract	Contract
	C_commit_equity	Equity
Initiators of the network	C_init_uni	University/research institutes
	C_init_assoc	Association
	C_init_comp	Company
	C_init_chamber	Chamber
	C_init_netw	Network
	C_init_devorga	Local development organization
	C_init_pub	Public institution
Actors in the network	C_act_comp	Companies
	C_act_uni	Universities/R&D institutes
	C_act_other	Other
Industry focus	C_industryspecific	1 = existent 0 = non-existent
Start-up support	C_founders	1 = existent 0 = non-existent
Common premises	C_premises	1 = existent 0 = non-existent
Lobbying	C_lobbying	1 = existent 0 = non-existent
Technology focus	C_technologyfocus	1 = existent 0 = non-existent

RESULTS: TYPES OF NETWORKS

In the following section, we present the results of our HAC analysis. We describe common results and characteristics of the clusters and identify distinctive characteristics that we define as key characteristics for each group of networks. In order to create a comprehensive typology, we name every group of networks after their specific characteristics and provide a concise description.

As the optimal number of clusters is determined within our method, we observe 11 groups of networks. The number of networks defines the cluster size and is illustrated in Figure 4. The average cluster size is 27.27 networks per cluster, whereas the median is 17. Only three clusters are above the average size, of which cluster #3 represents the largest with 86 networks. The other eight clusters range from seven to 26 networks. The smallest cluster is represented by cluster #8 with seven networks.

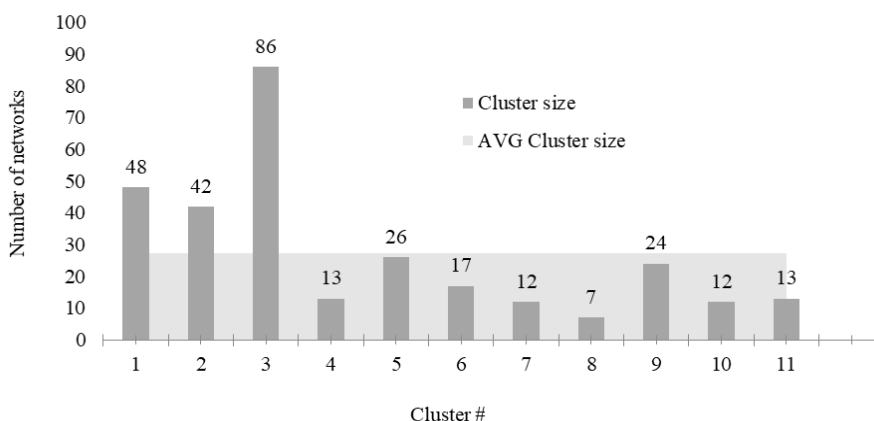

Figure 1: Cluster size: distribution of networks by cluster size (number of member networks).

Avid Persuaders

The first cluster represents 48 networks. The networks in the cluster show a diverse set of actors that are committed via either arrangements (54.17%) or contracts (43.75%). The networks are mostly controlled via hierarchical structures (95.83%). Complementarily, the governance of the network is determined by a leading organization (85.42%). Distinctive from other clusters, the networks in cluster #1 are partially initiated by chambers of commerce (27.08%). This is complemented by a comparably high frequency of engagement in lobbying activities (43.75%). However, the networks are not solely positioned in one value chain but are rather distributed across different stages in several value chains (70.83%) with a strong focus on a certain technology (91.67%).

Based on the previously described characteristics and features, we identify the following key characteristics for the networks in cluster #1:

- Engagement in lobbying activities
- Managed by a lead organization
- Hierarchical control structures

According to their key characteristics, we call the networks in cluster #1 the Avid Persuaders. The networks are focally initiated and managed and engage in start-up support and lobbying activities. The network is generally initiated by large focal organizations that seek to identify or develop new technologies. The objective of the network is clearly determined and tailored to the individual needs of the focal organization. The interactions and activities of the network are geared toward access to external resources that represent complementary capabilities not only for the leading organization, but also for the other network actors. However, other actors are not necessarily fully committed to the network via contracts.

Value Chain Drivers

The second cluster comprises 42 networks. The networks in cluster #2 are determined by shared governance forms (73.81%), which enable members to engage on equal participation rights within the network. This is also reflected by the high commitment of the members in the networks by contracts (92.86%). With a feature frequency of 73.81%, most of the network activities are concentrated within a single federal state. The actors in the networks are solely active across different stages within the same value chain (83.33%). Different from other clusters, the networks in cluster #2 also have redistributive (42.86%) goal identities as they aim for resource bundling to overcome common weaknesses. The networks are initiated either top-down (45.24%) or bottom-up (54.76%). Mostly, companies (64.29%) are involved in the initiation process; other actors are universities and public institutions (38.10%) as well as R&D institutes (26.19%).

Following the above-mentioned characteristics and features, we define the following key characteristics for the networks in cluster #2:

- Vertical positioning of actors within the same value chain
- Shared governance forms
- Geographical concentration in federal states

We call this group of networks the Value Chain Drivers that are characterized by joint decision makers who foster the development of value chains, concentrated within federal states. The organizations in a network are positioned within the same value chain. The networks follow objectives that target structural challenges and key technological changes for the value chain in order to stay competitive.

Collective Facilitators

With 86 networks, the third cluster represents the largest identified group of networks. Most of the networks in cluster #3 are emergent networks that are formed bottom-up by several organizations (79.09%). Complementary distinct characteristics of the networks are heterarchical (81.40%) structures and shared governance forms (94.19%). In most initiations of the networks, companies are engaged (77.91%) that are also present in every network (100%). A comparable high share of universities and R&D institutes (41.86%) is engaged in the initiation process as well. They also represent actors in the network in 93.02% of the networks. The actors in the network are positioned across different value chains as well as value chain stages (95.35%). All actors in the networks are committed by a binding contract (100%). The strong reciprocal network identity (90.70%) as well as the technology focus (74.42%) is consistent with the common characteristics of all clusters. Additionally, networks within this cluster partially engage in lobbying (37.21%) and start-up support activities (38.37%). The activities of the networks are often focused on a specific industry (59.30%).

With the above-described characteristics and features, we recognize the following key characteristics for the networks in cluster #3:

- Emergent formation (bottom-up)
- Heterarchical control structure
- Shared governance
- Lateral positioning of actors in the value chains

We call this group of networks the Collective Facilitators that are characterized by emergent formations with equal participation rights to increase the scope of action beyond value chain boundaries. The networks on the one hand aim to actively support companies, R&D facilities, and other institutions in order to facilitate connections and partnerships. Innovations, projects, and solutions are jointly developed and implemented. On the other hand, they promote general trends and technology developments. For example, the establishment of standards for new technologies

Niche Specialists

The fourth cluster represents 13 networks from our sample. Most networks in this cluster are top-down (92.31%) initiated by already established networks (100%). Complementary to the origin of the networks, the control structure is hierarchically organized (84.62%). However, a governance structure that is determined by a leading organization occurs in only 53.85% of the networks in this cluster. We further observe a geographical concentration of network activities within federal states (84.62%). The objectives of the networks are mainly reciprocal (84.62%). The actors in the networks are mostly committed with contracts (84.62%) and are rather positioned across different value chains and value chain stages (69.23%). The networks share a common technology focus (76.92%) and a comparably weak industry focus (30.77%).

Based on the previously described characteristics and features, the following key characteristics for the represented networks in cluster #4 are defined:

- Top-down initiated by established networks
- Tight technology focus
- Geographical concentration on federal states

We call this group of networks Niche Specialists that are described as network-initiated formations to foster specialized technologies within federal states. The integration of leading technology experts into the management of the networks ensures the achievement of long-term objectives. Target-oriented structures are established to achieve generally valid regulations and standardizations that are required for new technologies. The networks aim to develop and establish new key technologies.

Lateral Thinkers

The fifth cluster consists of 26 networks from our sample. In every network in cluster #5, companies (100%) as well as universities and research institutes are involved (100%). Both companies (73.08%) and universities and R&D institutes (34.62%) are engaged in the initiation process, complemented by public institutions (30.77%). The actors are positioned across different stages and value chains (92.31%) and share a reciprocal goal identity (92.31%). The networks are mostly managed very independently and are characterized by a network administration (80.77%). The initiation was conducted either top-down (46.15%) or bottom-up (53.85%). Control structures are slightly more hierarchical (65.38%). The cluster represents the highest specific technology focus (96.15%) as well as industry focus (92.31%) of all clusters. The networks in the cluster can be distinguished further as they provide support for their members to connect with start-ups or support start-ups directly (80.77%).

Regarding the previously described characteristics and features, we distinguish the following key characteristics for the networks in cluster #5:

- Network administration
- Positioning of actors across value chains and value chain stages (lateral)
- Strong industry and technology focus

- Interaction with start-ups

We call this group of networks the Lateral Thinkers that are characterized by independent industry centers seeking to identify innovative solutions through interaction with start-ups. Publicly funded non-profit associations foster the exchange of experience, knowledge, contacts, and ideas within a regional scope. The networks build an interface for entrepreneurs, scientists, technology seekers, as well as business angels to promote new technologies, which are of great relevance for the specialized companies that were already engaged in the establishment of the network. High-tech companies and start-ups in fast-growing industries represent the members. Companies are supported across all maturity phases of company development.

Transnational Opportunity Seekers

The sixth cluster comprises 17 networks. The networks in this cluster are rather initiated bottom-up (64.71%) and described by heterarchical structures (76.47%). Shared governance (52.94%) represents the preferred form of control by the networks and their actors. The networks within the cluster share common characteristics with other clusters such as a reciprocal network identity (94.12%) and actors committed by contracts (88.34%). The actors within the networks are rather positioned across stages on different value chains (64.71%) and are represented by companies (100%) as well as universities and R&D institutes (94.12%). Companies (82.35%), universities and R&D institutes (41.18%), as well as public institutions (47.06%) are engaged in the initiation process of the networks. A significant feature is observed within this cluster as all networks are engaged in international activities (100%) or relate to international partners. The networks are further characterized by a high technology (88.24%) and industry focus (58.82%).

Based on the previously described characteristics and features, the following key characteristics for the networks in cluster #6 are recognized:

- International scope
- Initiated by companies
- Strong reciprocal network identity

We call this group of networks the Transnational Opportunity Seekers that are jointly initiated by companies to achieve complementary capabilities across national borders. Registered non-profit associations aim to foster technology and market-oriented collaboration in science, research, and economics within an international scope. The actors intensify joint R&D activities with the possibility of opening new business fields. The network further represents its actors to the public and supports them in identifying experts as well as acquiring funds from the European Union.

Financially Resilient Connectors

The seventh cluster contains 12 networks, which are described by hierarchical structures (83.33%) and top-down (66.67%) initiation. All members are committed to the networks by monetary equity investments (100%). This enables the network to enhance innovation partnerships driven by connections with start-ups (50%). The cluster shares the characteristics of a strong technology focus (91.67%) and a reciprocal network identity (83.33%). Furthermore, companies (66.67%), public institutions (50%), as well as universities and R&D institutes (33.33%) are involved in the initiation of the networks. The positioning of the actors is a rather lateral (66.67%) distribution of the actors across value chains. The networks are primarily concentrated in regions (41.67%) or within a single federal state (33.33%). We also observe that especially small networks are represented within cluster #7.

Based on the above-described characteristics and features, we identify the following key characteristics for the networks represented in cluster #7:

- Actors are committed through equity
- Interaction with start-ups
- Strong technology focus

We call this group of networks Financially Resilient Connectors that we describe as purpose-driven enablers of financially sustainable innovation partnerships. The networks are initiated as limited liability companies and funded by public institutions and the European Union, together with partners from industry and science. They serve as a regional competence center to strengthen the region and entire industry. The networks reveal regional R&D capacities to promote and strengthen innovations and start-ups on behalf of the public sector. The partners from industry, research, and universities develop supra-regionally oriented forums, workshops, and working groups on current development trends in various fields of technology.

Local Trend Sponsors

With seven networks, the eighth cluster represents the smallest identified group of networks. Most networks within this cluster are initiated top-down (85.71%) by public institutions (71.43%). The networks are locally (100%) concentrated as many of them offer common premises (42.86%) for their members and partners. The clusters share common cluster characteristics of reciprocal goal identities (71.43%) as well as commitments based on contracts (71.43%). The actors within the networks are mainly based within the same value chain at different stages (71.43%), but also share common connections to start-ups

(57.14%). The networks seem generic as they have a comparably low technology focus (28.57) and are not specialized on specific industries (14.29%).

Based on their characteristics and features, we identify the following distinctive key characteristics for the networks in cluster #8:

- Local concentration
- Common premises
- Initiated by public institutions
- Vertical positioning of actors within the same value chain

We call this group of networks Local Trend Sponsors that are described as concentrated, publicly initiated, local interfaces for companies of all sizes. Public institutions that aim to shape and promote local industry districts or science parks determine the networks. The networks offer a meaningful point of contact for companies from different industries and sizes and act as a mediator with municipal partners. The networks draw attention to strategic trends and current developments at an early stage in order to involve actors in the development. A close network is offered by providing common premises and interaction with start-ups.

Regional Activists

The ninth cluster represents 30 networks. The networks within this cluster are top-down (95.83%) initiated by local development organizations (95.83%). Consistently, they have a hierarchical structure (91.67%) and are led by an organization (62.50%). They focus on several industries (41.67%) across different value chains (75%). Furthermore, the networks within this cluster share a reciprocal network identity (87.50%). Companies (100%) and universities and R&D institutes (87.50%) are among the actors in the networks. The networks also represent the interests of their actors as they engage in lobbying activities (50%). The technology focus of the networks is rather low (45.83%) compared with other clusters.

Regarding the above-mentioned characteristics and features, the following distinctive key characteristics for the networks in cluster #9 are determined:

- Top-down initiated by local development organizations
- Lobbying activities
- Strong local concentration

We call this group of networks Regional Activists that we describe as regional platforms to promote and foster selected business sectors holistically. The networks are based on initiatives from the federal states founded as collaborations to strengthen economic sectors within a region. They support actors in networking and development as well as in innovation and settlement projects. The networks bundle and coordinate resources between the actors for the purpose of knowledge transfer, exchange of experience, and initiation of joint projects. Therefore, they act as a mediator between politics, administration, and practitioners from industry, trade, and the service sector.

Associated Industry Supporters

The tenth cluster comprises 12 networks. Even though all the networks are at least partly initiated by associations (100%), they are not necessarily created top-down (58.33%). They also rather have a shared governance form (58.33%). Consistently with the large share of initiations by associations, many networks are engaged in lobbying activities (83.33%). Within the cluster, a high share of networks has an industry focus (91.67%). The scope of network activities is rather concentrated within federal states (66.67%). The actors consist of companies (100%) as well as universities and R&D institutes (91.67%). The positioning of the actors within a value chain is not specified as they are either at different stages of the same value chain (50%) or across different value chains (50%). As in the other clusters, the networks share common characteristics of a reciprocal goal identity (91.67%) as well as contract-based commitments (91.67%). The networks interact with start-ups (41.67%).

Based on the previously described characteristics and features, we identify the following distinctive key characteristics for the networks in cluster #10:

- Initiated by associations
- Lobbying activities
- Industry focus within federal states

We call this group of networks the Associated Industry Supporters. We describe this network type as sector-specific associations, based on company engagement to promote relevant topics, strengthen networks, and foster companies. With contacts from business, science, and politics, the associations represent an industry and form the interface between industry and politics. Additionally, projects are developed and implemented together with companies, research institutes, and local authorities to increase regional value added and competitiveness.

Dynamic Research Groups

The 11th cluster consists of 13 networks. The networks within this cluster are mainly initiated top-down (69.23%) by universities and research institutes (69.23%) as well as public institutions (30.77%). The formations have either a lead (46.15%) or shared (46.15%) governance form. Contrary to the common characteristics of other clusters, the actors in the networks within this cluster are mostly represented by universities and R&D institutes (92.31%), but only a few companies are involved (7.69%). Consistently, many actors are positioned at the same stage within the same value chain (53.85%). Additionally, a high degree of industry specialization (61.54%) as well as technology focus (84.62%) is observed. The commitment, however, is rather loose, as it is mostly based on arrangements (69.23%). The networks are primarily concentrated within federal states (76.92%).

Following the above-mentioned characteristics and features, we distinguish the following key characteristics for the networks in cluster #11:

- Commitment of actors via arrangements
- Initiated by universities and R&D institutes
- Actors are represented by universities and R&D institutes

We call this group of networks the Dynamic Research Groups that are characterized by university-driven, topic-specific centers to engage in multi-disciplinary research primarily in academic fields, including companies as sparring partners. The networks provide a collaboration platform for joint basic as well as applied research at the interface between science and industry. Interdisciplinary research activities are bundled for future-oriented complex topics. Institutes of universities as well as other research institutes in the region combine resources as well as know-how.

DISCUSSION

We identify 11 differential types of formal, inter-organizational innovation networks along a selection of distinctive characteristics. By ascribing each type, a unique name, we propose a comprehensive typology of formal inter-organizational innovation networks. Our proposed typology is presented in Table 4, which lists each network type with its key characteristics and a concise description. Furthermore, examples of networks are provided from our sample. The following section serves as a comparison of our defined network types with typologies and networks from previous studies. Thus, we fill existing gaps from previous research and identify possible discrepancies for further research. We might exclude networks from previous research that are not relevant in our typology, as we limit our observations to formalized innovation networks that focus on inter-organizational interaction

Table 4: Typology of formal inter-organizational innovation networks

Network name	Key characteristics	Description	Example networks
Avid Persuaders	<ul style="list-style-type: none"> • Engagement in lobbying activities • Managed by a lead organization • Hierarchical control structures 	Focally initiated and managed, engaged in start-up support and lobbying activities.	<ul style="list-style-type: none"> • Nutzfahrzeuge Schwaben • AQUANET Berlin Brandenburg • BIO.NRW
Value Chain Drivers	<ul style="list-style-type: none"> • Positioning of actors across value chain stages • Shared governance form • Geographical concentration on federal states 	Joint decision makers who foster the development of value chains, concentrated within federal states.	<ul style="list-style-type: none"> • AVIASPACE BREMEN • Netzwerk Logistik Mitteldeutschland • SolarInput
Collective Facilitators	<ul style="list-style-type: none"> • Emergent formation (bottom-up) • Heterarchical control structure • Shared governance • Lateral positioning of the actors in value chains 	Emergent formations with equal participation rights to increase the scope of action beyond value chain boundaries.	<ul style="list-style-type: none"> • Landesnetzwerk Mechatronik BW • Energieagentur Region Göttingen • PolymerMat
Niche Specialist	<ul style="list-style-type: none"> • Top-down initiated by established networks • Tight technology focus • Geographical concentration on federal states 	Network-initiated formations to foster specialized technologies within federal states.	<ul style="list-style-type: none"> • Wasserstoff- und Brennstoffzellen-Initiative Hessen • ikt.saarland • Competence Center Aerospace Kassel-Calden

Table 4 continued from previous page

Network name	Key characteristics	Description	Example networks
Lateral Thinkers	<ul style="list-style-type: none"> • Network administration • Lateral positioning of the actors in value chains • Strong industry and technology focus • Interaction with start-ups 	Independent industry centers seeking to identify innovative solutions through interaction with start-ups.	<ul style="list-style-type: none"> • IT-Forum Rhein-Neckar • Virtual Reality Berlin-Brandenburg • CyberForum
Transnational Opportunity Seekers	<ul style="list-style-type: none"> • International scope • Initiated by companies • Strong reciprocal network identity 	Jointly initiated by companies to achieve complementary synergies across national borders.	<ul style="list-style-type: none"> • Innovationszentrum Bahntechnik Europa • BalticNet - PlasmaTec • BioLAGO
Financially Resilient Connectors	<ul style="list-style-type: none"> • Committed by equity • Interaction with start-ups • Strong technology focus 	Purpose-driven enablers of financially sustainable innovation partnerships.	<ul style="list-style-type: none"> • Kompetenz-Netzwerk Mechatronik in Ostbayern • BIOPRO Baden-Württemberg • BioRegio STERN Management
Local Trend Sponsors	<ul style="list-style-type: none"> • Local concentration • Common premises • Initiated by public institutions • Vertical positioning of actors within the same value chain 	Concentrated, publicly initiated, local interface for companies of all sizes.	<ul style="list-style-type: none"> • Cluster Green City Freiburg • Cluster Medizintechnologie • Hamburg Kreativ Gesellschaft
Regional Activists	<ul style="list-style-type: none"> • Top-down initiated by local development organizations • Lobbying activities • Strong local concentration 	Regional platforms to promote and foster selected business sectors holistically.	<ul style="list-style-type: none"> • Forst und Holz Allgäu-Oberschwaben • Digitale Wirtschaft Schleswig-Holstein • Cluster Gesundheitswirtschaft Berlin-Brandenburg
Associated Industry Supporters	<ul style="list-style-type: none"> • Initiated by associations • Lobbying activities • Industry focus within federal states 	Sector-specific associations, based on company engagement to promote relevant topics, strengthen networks, and foster companies.	<ul style="list-style-type: none"> • media:net berlinbrandenburg • deENet Kompetenznetzwerk dezentrale Energietechnologien • BTS – Rail Saxony
Dynamic Research Groups	<ul style="list-style-type: none"> • Commitment via arrangements • Initiated by universities and R&D institutes • Actors represented by universities and R&D institutes 	University-driven, topic-specific centers to engage in multi-disciplinary research primarily in academic fields, including companies as sparring partners.	<ul style="list-style-type: none"> • Bremen Research Cluster for Dynamics in Logistics • COALA Kompetenzzentrum • Niedersächsisches Forschungszentrum Fahrzeugtechnik

As we focus on the identification of different types of innovation networks, it is not surprising that most networks within the sample indicate a strong technology focus. Consistently with the definition of networks by Sydow (1992), we observe a high frequency of reciprocal network identities among our networks. As all observed networks have a diverse actor structure, the prerequisite for inter-organizational interaction is well met. Table 5 summarizes network types from previous literature for which we assume overlapping characteristics with our identified networks.

Table 5: Assignment of the identified networks to previous literature

Networks identified within this study	Networks with similar characteristics from previous literature	Reference
Avid Persuaders	Dominated Networks	(Child <i>et al.</i> , 2005)
	Lead Organization-Governed Networks	(Provan & Kenis, 2008)
	Federated Innovation Networks	(Lyytinen <i>et al.</i> , 2016)
Value Chain Drivers	Vertical Partnerships	(Dussauge & Garrette, 1999)
	Clan Innovation Networks	(Bau <i>et al.</i> , 2014)
	Vertical Integrations	(Lyytinen <i>et al.</i> , 2016)
Collective Facilitators	Cross-Industry Agreements	(Dussauge & Garrette, 1999)
	Equal Partner Networks	(Child <i>et al.</i> , 2005)
	Participant-Governed Networks	(Provan & Kenis, 2008)
	Knowledge and Learning	(Bau <i>et al.</i> , 2014)
	Anarchic Innovation Network	(Lyytinen <i>et al.</i> , 2016)
Niche Specialist	N/A	N/A

Table 5 continued from previous page

Networks identified within this study	Networks with similar characteristics from previous literature	Reference
Lateral Thinkers	Structure-based Innovation Networks	(Wissema & Euser, 1991)
Transnational Opportunity Seekers	Clan Innovation Networks	(Dussauge & Garrette, 1999)
Financially Resilient Connectors	Strategic Alliances	(Child <i>et al.</i> , 2005)
	Financial Procurement	(Bau <i>et al.</i> , 2014)
Local Trend Sponsors	Regional Innovation Systems	(Cooke <i>et al.</i> , 1997)
	Clusters	(Porter, 1998)
	Industrial Districts	(Inkpen & Tsang, 2005)
Regional Activists	Regional Innovation Systems	(Cooke <i>et al.</i> , 1997)
	Regional Networks	(Sydow, 2001)
Associated Industry Supporters	Associations as Innovation Platforms	(Mieke, 2008)
Dynamic Research Groups	Dynamic Networks	(Snow, Miles, & Coleman, 1992)
	R&D Partnership	(Hagedoorn, 2002)
	R&D Network	(Priestley & Samaddar, 2007)

Avid Persuaders

We identify the Avid Persuaders as equivalent to the Dominated Network described by Child *et al.* (2005) as well as the Lead-Organization-Governed Network defined by Provan & Kenis (2008). The network is initiated, managed, and controlled by a focal organization. Additionally, we identify significant engagement in lobbying activities and interactions with start-ups. The focal organization is suspected to have high bargaining power; however, the other organizations are not necessarily committed by contracts. Thus, they are rather loose collaboration partners based on agreements. Lyytinen *et al.* (2016) describe this organizational form as the Federated Innovation Network, which consists of a heterogeneous set of actors, integrated into a hierarchical control structure.

Value Chain Drivers

Value Chain Drivers are characterized by collaboration of actors within the same value chain, which are concentrated in a single federal state. The focus within these networks is on innovation among the value chain and does not necessarily include usual business relations between actors in the value chain. Dussauge & Garrette (1999) describe Vertical Partnerships between non-competing firms as a form of strategic alliances. However, we do not generally exclude competitors from Value Chain Drivers. A crucial aspect is mentioned as vertical partnerships might create conflicts as a result of different bargaining powers of the partners (Dussauge & Garrette, 1999). This issue is possibly targeted within the Value Chain Drivers, as we observe a high frequency of shared governance forms. As Bau, Bentivegna, & Forster (2014) identify the informal innovation network of Vertical Integration, we observe a strong consistency with the Value Chain Drivers, as both act along the value chain and are geographically limited to national borders or federal states. We assume that the Value Chain Drivers represent a formalized pendant to Vertical Integration. Additionally, Lyytinen *et al.* (2016) define the Clan Innovation Network, which shares common characteristics with the Value Chain Drivers, such as a homogeneous set of actors that are driven by common interests while no hierarchical control structure is established.

Collective Facilitators

We regard the Collective Facilitators as the most common type of formal innovation networks occurring in Germany, as they represent the largest group in our sample. The network is an emergent formation with equal participation rights that enables its actors to increase their scope of action beyond their value chain boundaries. This network type indicates similarities to the Equal-Partner Network described by Child, Faulkner, & Tallman (2005) as well as the Participant-Governed Network defined by Provan & Kenis (2008). The network is set up and controlled by multiple actors. The power is shared among different actors, which does not necessarily imply that all network members have equal power (Child *et al.*, 2005). The actors within Collective Facilitators aim to leverage their complementary capabilities. Thus, actors from different industries build lateral connections, which corresponds to Cross-Industry Agreements from Dussauge & Garrette (1999). We further observe overlapping features with the informal innovation network Knowledge and Learning described by Bau, Bentivegna, & Forster (2014). Both are characterized by a very diverse and large set of actors who aim to access external knowledge and bridge internal knowledge gaps. We further indicate overlapping characteristics with the Anarchic Innovation Network described by Lyytinen *et al.* (2016). A high level of knowledge heterogeneity and the absence of hierarchical control structures characterize this network.

Niche Specialists

The Niche Specialists represent a group of networks that are initiated by established networks in order to occupy a niche for a specialized technology. A generalist network initiates a special purpose-focused network benefiting from its existing network

structures. Company-wide initiatives and networks also initiate subordinated networks that are targeted at certain regions or technologies (BMW, 2020).

Lateral Thinkers

The Lateral Thinkers are independent industry centers seeking to identify innovative solutions primarily through interaction with start-ups. The governance form of this network is comparable with the network administrative organization of Provan & Kenis (2008). The strong industry and technology focus represents similarities to Strategic Alliances that aim to access and establish new technologies (Child *et al.*, 2005; Dussauge & Garrette, 1999). The Lateral Thinkers inhibit characteristics of Cross-Industry Agreements described as collaboration “(...) formed by companies from totally different industries which seek to diversify their activities by leveraging their complementary capabilities” (Dussauge & Garrette, 1999, p. 55). Different from this definition, the actors within our Lateral Thinkers have their origin within the same industry. This is also reflected by Structure-Based Innovation Networks defined by Wissema & Euser (1991), in which companies from a sector interact to achieve common innovation.

Transnational Opportunity Seekers

We identify the Transnational Opportunity Seekers as networks that are jointly initiated by companies in order to achieve complementary synergies across national borders. Similar to the informal innovation network type International Scope described by Bau *et al.* (2014), Transnational Opportunity Seekers can be represented by large projects that are promoted by the European Union. This is also assumed to be a motivational factor to participate in such networks to get access to public funding.

Financially Resilient Connectors

We identify networks that consist solely of equity-committed actors. We call these networks Financially Resilient Connectors that represent a purpose-driven enabler of financially sustainable innovation partnerships. Even though these networks represent Joint Ventures of different organizations, they do not necessarily share the common characteristics of described forms of Joint Ventures in previous research (e.g. Dussauge & Garrette, 1999; Killich, 2011). We observe similarities to the informal innovation network, called Financial Procurement, described by Bau *et al.* (2014). As the networks rather consist of a small number of actors, they share a strong common objective. This is represented by the strong technology focus of the Financially Resilient Connectors. To access and achieve new innovations, the networks seek connections with other innovators and start-ups. As access to financial resources for innovation projects is limited, the network management can access the equity committed by its actors to initiate projects.

Local Trend Sponsors

The Local Trend Sponsors are highly concentrated networks that are initiated by public institutions to offer a local interface for companies of all sizes. The networks can include local hubs or innovation and technology centers that also offer common premises for their members. The innovation centers are politically supported and therefore initiated by public institutions, but also involve local universities and R&D institutes. The benefits of local concentration of companies are widely accepted and seen as a driver for the direction and pace of innovation (Porter, 1998). We find Local Trend Sponsors related to Industrial Districts, described by Inkpen & Tsang (2005). Their Industrial Districts consist of independent firms that operate in the same or related market segments and benefit from agglomeration effects. Cooke *et al.* (1997) describe such local concentrations as Regional Innovation Systems that are also regarded as inter-organizational networks for SMEs (Kofler & Marcher, 2018).

Regional Activists

We identify a group of networks that we call the Regional Activists. These networks are focused regional platforms to promote and foster selected business sectors holistically. Contrary to Regional Networks defined by Sydow (2001), the Regional Activists are described by hierarchical control structures. We assume that this results from the engagement of local development organizations during the initiation process of the networks. We see these organizations as the determining actors within the network. They can also be highly influenced by political initiatives and programs. The Regional Activists correspond to Regional Innovation Systems (Cooke *et al.*, 1997). Owing to the strong local focus, we assume a high relevance for SMEs (Kofler & Marcher, 2018).

Associated Industry Supporters

We identify Associated Industry Supporters as sector-specific networks that promote relevant topics, strengthen networks, and foster interaction between companies. They also represent the common interests of the actors within the network. Mieke (2008) has already described industry associations as a platform for innovations, especially for SMEs. They form a forum for discussion and joint processing of innovation-oriented technological areas. According to Mieke (2008), industry associations can bring together companies with complementary information channels and assessment skills that are willing to provide early information and thus contribute to a more active involvement in future technological issues. Based on the insights given by Mieke (2008), we assume that the Associated Industry Supporters benefit from the involved skill set and connections of the engaged industry associations. We suppose that the Associated Industry Supporters can play a crucial role within the innovation process of SMEs.

Dynamic Research Groups

We describe rather loose forms of research collaborations between actors from the research and university environment as Dynamic Research Groups. Previous research has already identified several different collaboration forms for R&D. Priestley & Samaddar (2007) describe R&D Networks as having a decentralized governance structure and a low intensity of competition. Dynamic Research Groups consist mainly of relations between universities and research institutes that maintain only a few relations with single, selected industry partners. Therefore, we have to make a differentiation from common R&D Partnerships that consist of inter-firm relations (Hagedoorn, 2002). The rather loose form of collaboration of Dynamic Research Groups is mainly based on agreements. Such loose formations are also described as Dynamic Networks, which inhibit the possibility of continuous network adaptations (Snow *et al.*, 1992).

Based on the number of members, our typology includes three major network types, Collective Facilitators, Avid Persuaders, and the Value Chain Drivers. Each type follows a different approach to enhance the exchange of knowledge among its actors and to enable access to external resources. We find that most of these network types are open to include SMEs, which does not necessarily mean that they are also the most suitable approaches for SMEs. Large networks with a broad focus could offer opportunities to internationalize or to enter new markets. As the business activities of SMEs are often geographically concentrated, we assume that especially networks with a regional and local focus, such as Regional Activists, Associated Industry Supporters, and Local Trend Sponsors, could enhance interaction with partners from science and industry to foster innovation. The Financially Resilient Connectors require a monetary investment that could indicate a barrier for SMEs to enter these networks. Capital provided by state initiative programs could reduce this barrier. Thus, this network could also reflect a very interesting approach to foster innovation among SMEs.

CONCLUSION, CONTRIBUTION, AND LIMITATIONS

Our study serves as guidance for researchers, practitioners, and policy makers in the jungle of innovation networks. We address the lack of a comprehensive typology of innovation networks that combines the lone-standing attributes of previous studies into a holistic network typology. To our knowledge, we offer the first comprehensive typology of formal inter-organizational innovation networks that is grounded in theory as well as empirical data. As we find a clear answer to our formulated research question on the identification of different types of innovation networks, we can give several theoretical and practical implications. We believe that the mixed method approach including a cluster analysis suits the purpose of this paper very well. However, there are various limitations resulting from our applied methods and sampling procedure.

We contribute to the literature by introducing the first comprehensive, empirically grounded network typology. Thereby, we confirm previously identified typologies and networks and reveal differences by comparing our findings with existing literature. Furthermore, we find a new network type—Niche Specialist—and refine and clarify existing types. Methodically, we contribute to the field of network research by applying a mixed method approach. We recommend this method as a very suitable approach to identify and verify network types based on their empirically identifiable characteristics. Previous studies analyze network types and their characteristics using qualitative data, yet there is no empirically grounded network model combining and integrating these lone-standing attributes from either an academic or a practitioner-oriented point of view. By applying an exploratory sequential mixed method approach, we provide a typology of innovation networks that takes into account previous theory as well as purposefully generated empirical data. Our typology of innovation networks is therefore well suited to serve as a basis for further research. It enables scholars to analyze networks and related topics like network performance or network benefits based on a precise model including clearly defined and delineated network types. So far existing typologies are not able to deliver a common basis for analysis and discussion, as they are not comprehensively depicting the empirical reality of networks.

The typology provides guidance for all actors already involved in innovation networks or striving to engage in networks in line with their innovation strategy. As every organization possesses a different set of resources, the need to access external resources is widely diverse across companies and sectors. Our typology can enable organizations to identify suitable networks regarding their individual needs, based on, e.g., geographical considerations, the ability and willingness to take individual influence or responsibility, or the aspired business support focus. Companies can choose network involvement targeting research and development and scientific partnerships, marketing, or a combination of motives. They can purposefully enter in networks that foster political contacting or that focus on business partnerships in privately administered associations. The typology can thereby be applied across industries as well as actor perspectives. The framework also serves as an orientation guide for the initiation of new networks or in formalizing existing informal innovation networks. As many networks are supported and funded by public institutions, federal administrations, or the German and European governments, this typology provides guidance for policy makers. The typology can be applied to better implement political and economic instruments to promote selected network types. We propose reducing barriers for SMEs to enter innovation networks by offering financial and organizational support.

Our study incorporates certain limitations resulting from the applied sampling procedure and methods. As all considered networks are identified from the online listing provided by “Clusterplattform Deutschland”, we are aware of possible exclusions of network types that might not meet the benchmark of the platform. The listing enables a structured sampling procedure to identify formalized networks at a comparable level of data and information quality. Still, we cannot ensure our typology to be complete. Nevertheless, we assume it is unlikely that other forms play a crucial role in undermining our results,

if they occur rarely. Furthermore, we cannot exclude the possibility that our sampled networks are more actively influenced by political interventions than networks not listed on the platform. Additionally, our data set is geographically limited to Germany. We do not include observations regarding location, founding year, and size in our analysis. Therefore, we do not control for correlations between these characteristics and the network types. Public funding programs as well as technological, economic, and environmental developments might influence the time of foundation. Furthermore, promotions of federal states could influence the location, size, and emergence of specific network types. Nevertheless, we do not regard these aspects as important in influencing our typology.

The selection of network characteristics and features as well as the coding process within the qualitative content analysis underlie critical subjective elements of interpretation. To reduce this, the coding process is partially counter-tested among the authors. Nevertheless, certain elements of subjective interpretation could remain. We excluded networks during the coding process, as insufficient data were accessible through publicly available resources at the time of the analysis. By excluding these networks, we possibly limit the outcome of the cluster analysis as well as the resulting typology. By only considering publicly available sources, we may lack information that would provide additional insights into the observed networks.

As networks play a crucial role in innovation strategies as well as economic developments, we suggest the analysis of the performance and effectiveness of different network types. The influence of specific characteristics on the performance of a network is of particular interest, as it could lead to contributions to steer the outcome of networks. Thus, it could support practitioners and policy makers during the initiation and promotion of certain network types.

By enriching the existing data set of identified formal, inter-organizational innovation networks, we expect to gain possible insights into the actor structure, the degree of involvement, geographical connections, as well as the temporal development of different network types. Additionally, private information from the networks could validate our findings and generate additional insights into the observed networks. We propose to analyze the identified networks in terms of their relevance and benefits for SMEs from both the network as well as the company perspectives. As our data set is geographically limited, we suggest enriching the data set by additional data from Germany as well as from other European countries. This could yield more insights regarding national or regional differences in network types.

REFERENCES

- [1] Agostini, L., & Nosella, A. (2019). Inter-organizational relationships involving SMEs: A bibliographic investigation into the state of the art. *Long Range Planning*, 52(1), 1–31. <https://doi.org/10.1016/j.lrp.2017.12.003>
- [2] Bau, F., Bentivegna, T., & Forster, M. (2014). Ad-hoc innovation networks of European SMEs. A typology of networks based on a multiple case study. Retrieved from https://www.researchgate.net/profile/Frank_Bau/publication/268895381_Ad-hoc_Innovation_Networks_of_European_SMEs_A_typology_of_networks_based_on_a_multiple_case_study/links/547ad3400cf2a961e487b6e7/Ad-hoc-Innovation-Networks-of-European-SMEs-A-typology-of-networks-based-on-a-multiple-case-study.pdf
- [3] Child, J., Faulkner, D., & Tallman, S. (2005). *Cooperative strategy: managing alliances, networks and joint ventures* (2nd ed.). New York: Oxford University Press.
- [4] Cooke, P., Gomez Uranga, M., & Etzebarria, G. (1997). Regional innovation systems: Institutional and organisational dimensions. *Research Policy*, 26(4–5), 475–491. [https://doi.org/10.1016/S0048-7333\(97\)00025-5](https://doi.org/10.1016/S0048-7333(97)00025-5)
- [5] Delgado, M., Porter, M. E., & Stern, S. (2016). Defining clusters of related industries. *Journal of Economic Geography*, 16(1), 1–38. <https://doi.org/10.1093/jeg/lbv017>
- [6] Dussauge, P., & Garrette, B. (1999). *Cooperative strategy: Competing successfully through strategic alliances*. Chichester: John Wiley & Sons, Ltd.
- [7] Everitt, B., Landau, S., Leese, M., & Stahl, D. (2011). *Cluster analysis* (5th ed.; D. Balding, N. Cressie, G. Fritzmaurice, H. Goldstein, G. Molenberghs, D. Scott, ... S. Weisberg, Eds.). London: John Wiley & Sons, Ltd.
- [8] Friese, M. (1998). *Kooperation als Wettbewerbsstrategie für Dienstleistungsunternehmen* (M. Kleinaltenkamp, H. Engelhardt, A. Meyer, H. Mühlbacher, & B. Stauss, Eds.). <https://doi.org/10.1007/978-3-663-01487-4>
- [9] Hagedoorn, J. (2002). Inter-firm R&D partnerships: an overview of major trends and patterns since 1960. *Research Policy*, 31(4), 477–492. [https://doi.org/10.1016/S0048-7333\(01\)00120-2](https://doi.org/10.1016/S0048-7333(01)00120-2)
- [10] Hagenhoff, S. (2008). *Innovationsmanagement für Kooperationen: Eine instrumentenorientierte Betrachtung*. Göttingen: Universitätsverlag Göttingen, 369 p.
- [11] Inkpen, A., & Tsang, E. (2005). Social capital, networks, and knowledge transfer. *The Academy of Management Review*, 30(1), 146–165.
- [12] Killich, S. (2011). Formen der Unternehmenskooperation. In *Netzwerkmanagement* (pp. 13–22). Springer, Berlin, Heidelberg. https://doi.org/10.1007/978-3-642-19333-0_2
- [13] Kofler, I., & Marcher, A. (2018). Inter-organizational networks of small and medium-sized enterprises (SME) in the field of innovation: A case study of South Tyrol. *Journal of Small Business & Entrepreneurship*, 30(1), 9–25. <https://doi.org/10.1080/08276331.2017.1401202>
- [14] Lyytinen, K., Yoo, Y., & Boland, R. J. (2016). Digital product innovation within four classes of innovation networks. *Information Systems Journal*, 26(1), 47–75. <https://doi.org/10.1111/isj.12093>
- [15] Mieke, C. (2008). Branchenverbände als Innovationsplattform. In *Produkt- und Prozessinnovationen in Wertschöpfungsketten* (1st ed., pp. 107–124). https://doi.org/10.1007/978-3-8349-9765-4_6

- [16] Morschett, D. (2003). Formen von Kooperationen, Allianzen und Netzwerken. In *Kooperationen, Allianzen und Netzwerke* (pp. 387-413). Gabler Verlag, Wiesbaden. https://link.springer.com/chapter/10.1007/978-3-322-99865-1_16
- [17] Payer, H. (2008). Netzwerk, Kooperation, Organisation - Gemeinsamkeiten und Unterschiede. In S. Bauer-Wolf, H. Payer, & G. Scheer (Eds.), *Erfolgreich durch Netzwerkkompetenz* (pp. 5–22). <https://doi.org/10.1007/978-3-211-73127-7>
- [18] Porter, M. E. (1998). Clusters and the new economics of competition. *Harvard Business Review*, 76(6), 77–90.
- [19] Powell, W. (1990). Neither market nor hierarchy: Network forms of organization. In *Research in Organizational Behavior* (Vol. 12, pp. 295–336). <https://doi.org/10.1590/s1415-65552003000200016>
- [20] Priestley, J. L., & Samaddar, S. (2007). Multi-organizational networks: three antecedents of knowledge transfer. *International Journal of Knowledge Management (IJKM)*, 3(1), 86-99. <https://doi.org/10.4018/jkm.2007010106>
- [21] Provan, K. G., Fish, A., & Sydow, J. (2007). Interorganizational networks at the network level: A review of the empirical literature on whole networks. *Journal of management*, 33(3), 479-516. <https://doi.org/10.1177/0149206307302554>
- [22] Provan, K. G., & Kenis, P. (2008). Modes of network governance: Structure, management, and effectiveness. *Journal of public administration research and theory*, 18(2), 229-252. <https://doi.org/10.1093/jopart/mum015>
- [23] Schilling, M. A., & Phelps, C. C. (2007). Interfirm collaboration networks: The impact of large-scale network structure on firm innovation. *Management science*, 53(7), 1113-1126. <https://doi.org/10.1287/mnsc.1060.0624>
- [24] Snow, C. C., Miles, R. E., & Coleman, H. J. (1992). Managing 21st century network organizations. *Organizational Dynamics*, 20(3), 5–21.
- [25] Sydow, J. (1992). *Strategische Netzwerke: Evolution und Organisation* (Vol. 100). Springer-Verlag. <https://doi.org/10.1007/978-3-322-86619-6>
- [26] Sydow, J. (2001). Management von Netzwerkorganisationen—Zum Stand der Forschung. In *Management von Netzwerkorganisationen* (pp. 293-339). Gabler Verlag. https://doi.org/10.1007/978-3-322-91999-1_11
- [27] Täuscher, K., & Laudien, S. M. (2018). Understanding platform business models: A mixed methods study of marketplaces. *European Management Journal*, 36(3), 319-329. <https://doi.org/10.1016/j.emj.2017.06.005>
- [28] Ward Jr, J. H. (1963). Hierarchical grouping to optimize an objective function. *Journal of the American statistical association*, 58(301), 236-244. <https://doi.org/10.1080/01621459.1963.10500845>
- [29] Williamson, O. E. (1981). The economics of organization: The transaction cost approach. *American journal of sociology*, 87(3), 548-577. <https://doi.org/10.1086/227496>
- [30] Wissema, J. G., & Euser, L. (1991). Successful innovation through inter-company networks. *Long Range Planning*, 24(6), 33-39. [https://doi.org/10.1016/0024-6301\(91\)90041-L](https://doi.org/10.1016/0024-6301(91)90041-L)
- (*Full reference list is available upon request from the corresponding author.)

APPENDIX A: Initial network characteristics considered in the qualitative content analysis

Characteristic	Features
Origin	Top-down Bottom-up
Network positioning	Superior network Sub-network Independent
Network cooperations	1=existent 0=non-existent
Legal structure	Registered association (e.v.) GmbH GmbH & Co. KG GbR Foundation "Körperschaft des öffentlichen Rechts" Project or initiative by an organization
Legal representation (imprint)	Special purpose vehicle SPE by another organization/company Organization for local development Natural person from board Research facility or university Company Corporation under public law Chamber of commerce
Power distribution	Focal Polycentric
Control	Hierarchical Heterarchical
Governance	Lead organization Network administration Shared
Network management	Independent management University/research organization Local development organization Company representatives Chamber representatives Association representatives Public institution
Network identity	Reciprocal Redistributive
Structure	Simple Complex
Geographical extent	Local Regional State National International
Duration	Temporary No limit
Functional purpose	Procurement Production Marketing Customer R&D
Direction	Horizontal Vertical Lateral
Membership	Open Closed Partly open
Requirements for membership	Industry specific Branch location No requirements
Bond intensity	Low Medium High

Table continued from previous page.	
Characteristic	Features
Commitment	Arrangement Contract Equity
Initiators of the network	University/research institute Association Company Chamber Cluster/network Local development organization Public institution
Actors in network	Companies Universities/R&D institutes Other
Supporting the search for skilled workers	1=existent 0=non-existent
Industry specific	1=existent 0=non-existent
Start-up support	1=existent 0=non-existent
Common premises	1=existent 0=non-existent
Lobbying	1=existent 0=non-existent
Technology focus	1=existent 0=non-existent

Song, S.J. & Peng, W. (2020). How do price promotion and donation promotion affect consumer's impulsive buying behavior? Based on face awareness and regulatory focus to the interaction of promotion patterns. In *Proceedings of The 20th International Conference on Electronic Business* (pp. 164-172). ICEB'20, Hong Kong SAR, China, December 5-8.

How Do Price Promotion and Donation Promotion affect Consumers' Impulsive Buying Behavior?: Based on Face Awareness and Regulatory Focus to the Interaction of Promotion Patterns

(Full Paper)

Sujuan Song*, School of Business, Sichuan Agricultural University, Chengdu, China,
songsujuan9695@163.com

Wei Peng, School of Business, Sichuan Agricultural University, Chengdu, China, pw7@163.com

ABSTRACT

This study aims to investigate the impact of price promotion and donation promotion on consumers' impulsive buying behavior, and analyze the interaction effect of face awareness and regulatory focus in the above effects by using the situational simulation and questionnaire methods. According to the results, the price promotion can stimulate consumers to produce impulsive buying behavior more than donation promotion. Through the two-factor analysis of variance to test the interaction effect, it is concluded that in the situation of price promotion, there is no significant difference between the likelihood of impulsive buying behavior between high face awareness consumers and low face awareness consumers; However, in the situation of donation promotion, high face awareness consumers are more likely to produce impulsive buying behavior than low face awareness consumers; And whether in the situation of price promotion, or in the situation of donation promotion, prevention focus consumers are more likely to produce impulsive buying behavior than promotion focus consumers. The conclusions of this study are of reference significance for revealing the factors that affect consumers' impulsive buying behavior and helping companies to formulate promotional strategies.

Keywords: Price promotion, donation promotion, face awareness, regulatory focus, impulsive buying behavior.

*Corresponding author

INTRODUCTION

In today's fierce market competitive environment, sellers usually take promotional measures to gain more market share. Promotion, as the most commonly used marketing method, is a kind of comprehensive strategic activity that sellers transmit relevant information to the market to promote or create the demand for the products, so as to stimulate consumers' purchase desire (Kotler, 2009). According to whether it is directly related to money, some scholars divide promotion into monetary promotion and non-monetary promotion. Price promotion and donation promotion are typical representatives of both (Campbell & Diamond, 1990). The research on sales promotion has become a hot topic in academic circles. In recent years, domestic and foreign scholars mainly focus on the impact of sales promotion on consumer decision-making. For example, some scholars have empirically analyzed the influence of factors such as promotion frequency and promotion intensity on consumers' impulse purchase intention (Kalwani & Yim, 1992; Mela, Gupta & Lehmann, 1997; Sun, Li & Wang, 2007). However, most of these studies are based on the interests of consumers themselves. With the advancement of society and the enhancement of consumers' awareness of social responsibility, consumers no longer only pursue their own interests, but also hope to take social interests into account, which has led to the continuous emergence of promotional modes for donations (Duan *et al.*, 2018), in which donation promotion is a typical embodiment of such a promotion mode. However, few scholars have made a comparative study of price promotion and donation promotion, and lack of theoretical research and empirical analysis on consumer impulsive buying behavior from the perspective of consumer psychology and personality traits. Then, how does sales promotion work as an effective tool for sellers to attract customers and stimulate consumers to purchase? What are the different effects of price promotion and donation promotion on consumers' impulsive buying behavior? How do face awareness and regulatory focus affect consumers' impulsive buying behavior in the situation of price promotion and donation promotion respectively? In order to get the answers to the above questions, this paper attempts to explore the different psychological decision-making mechanisms of consumers in the situation of price promotion, donation promotion, face awareness and regulatory focus, so as to supplement the research in related fields.

LITERATURE REVIEW

Impulse Buying Behavior

As early as 60 years ago, consumer impulse buying behavior has become one of the hot topics in academic circles. The early researches on consumer impulse buying behavior mainly focused on the definition of its concept (Li & Jing, 2014). For example, DuPont (2014) initially defined impulsive buying behavior as unplanned purchase, which laid the foundation for the definition of impulsive purchase. Rock (1987) thinks that impulsive purchase cannot be equated with unplanned purchase, and defines impulsive purchase from the perceptual perspective, that is, impulsive purchase is an irresistible buying behavior accompanied by strong emotional experience and hedonic demand, which is caused by the failure of self-control. After the

1990s, many scholars began to explore which factors would affect consumers' impulse buying behavior, and some scholars summarized these factors into internal factors (consumers' impulsive buying intention, self-control ability, etc.) and external environmental factors (marketing incentives) (Li & Jing, 2014). In recent years, domestic and foreign scholars have further deepened the research on consumers' impulsive buying behavior, such as exploring the influence of promotion time on consumers' impulsive purchase (Liu *et al.*, 2012), the influence of product types on consumers' impulsive purchase (Mishra & Mishra, 2010), and the influence of consumers' emotion on impulsive purchase (Sohn & Lee, 2017). Through the analysis of literature, it is not difficult to find that more existing studies from the perspective of marketing incentives and consumer impulse buying intention propensity to analyze the factors affecting consumer impulse purchase, and constantly explore, deepen and integrate these factors. However, there is a lack of research on the factors influencing consumers' impulsive buying behavior from the perspective of consumers' psychology and personality traits. In order to narrow this gap, this study respectively explores the influence of consumers' psychological level -- face awareness and personality trait -- regulatory focus on consumers' impulsive buying behavior on the basis of promotional incentives, in order to enrich the research on consumers' impulsive buying behavior.

Research on Promotion Effect

Promotion is a marketing activity that can accelerate consumer willingness-to-buy or increases the short-term sales volume of seller's products. It is an inducement for sellers to stimulate consumers to purchase a certain product (Li & Jing, 2014). Previous studies have shown that sales promotion significantly affect consumers' impulsive buying behavior. Scholars such as Luo *et al.* (2010) proposed that greater the perceived value brought to consumers by product advertising, price reduction and sales promotion, the greater the likelihood that consumers are to produce impulsive buying behavior.

With the development of commercial economy, there are more and more kinds of promotion patterns, including price promotion, gift promotion, full discount promotion and full delivery promotion, etc., among which price promotion and gift promotion are the most commonly used promotion patterns. However, studies have shown that price promotion and gift promotion have different effects on consumer decision-making. For example, Zhang (2007) proposed that different promotion expressions of the same product would bring consumers different perceived benefits and buying intentions. Zeng and Hao (2015) further proposed that under the same promotional value, price promotion brings consumers greater perceived value than gift promotion. In addition, different promotional intensities also have a significant impact on consumers' purchasing decisions. Hao proposed that under the normal promotional intensity of sellers, consumers can reduce expenditures and have higher perceived value, so the possibility of purchase is greater. When the promotion intensity exceeds the normal range, consumers will have doubts about the product quality, thus reducing the possibility of purchase (Hao, Gao & Jia, 2008).

Face Awareness

Compared with Western consumers who advocate individualism culture, they value personal reputation and social status, while eastern consumers who are nurtured by collectivism culture pay more attention to face (Zhang Cao & Grigoriou, 2011; Wan, Poon & Yu, 2016). Face refers to the social and open self-image cognition aroused by the attitude and behavior of others in the process of getting along with other individuals in the society (Bao, Zhou & Su, 2003). The face awareness is an individual's desire to maintain and improve face and prevent loss of face, resulting in social behaviors related to others (Zhang, Cao & Grigoriou, 2011). People with higher face awareness usually show higher social needs when making purchase decisions, and pay more attention to the external attributes of the product (such as brand, price, etc.) and the impact of purchasing the product on others.

Impression management theory is the theoretical basis to explore the influence of face awareness on consumer behavior. When people *get along* with others, they tend to take the initiative to manage and spread their good self-image (Grant & Mayer, 2009). The motivation of impression management stimulates consumers to produce pro-social behavior and consumers' awareness of face care, finally produces impulsive buying behavior. At the same time, in terms of sales promotion, compared with price promotion, the donation promotion is directly related to the interests of others and the society, and has a stronger pro-social nature, so it can attract consumers' attention more. That is, the pro-sociality of the donation promotion can get others' recognition and praise more, thus improving the face.

Regulatory Focus

The theory of regulatory focus refers to a certain way or tendency taken by individuals to achieve a specific behavior or goal (Yuan, 2017). The theory of regulatory focus distinguishes two different regulatory focuses: one is the promotion focus related to growth and development; the other is the prevention focus related to prevention and protection. In the process of achieving the goal, promotion focus consumers are more likely to imagine the desired goal state as a success, and more concerned about whether there is a positive outcome. Prevention focus consumers tend to think of the desired target state as safety and responsibility, and care more about whether there will be negative results. Aaker *et al.* (2001) first introduced the theory of regulatory focus into the consumption situations, and then a large number of empirical studies in the field of consumption behavior emerged. These studies focus on two aspects: on the one hand, regulatory focus can directly affect consumers' purchase decisions as their own characteristics. For example, consumers with different regulatory focus characteristics have significant differences in shopping decision-making. On the other hand, regulatory focus can lead to consumer persuasion knowledge, thus affecting the effect of consumers' persuasion, that is, different characteristics of regulatory focus consumers will produce different behaviors and results in the face of different information situations. Regulatory focus can have an indirect impact on consumers' decision-making. For example, Simmons *et al.* (2016) believes that the matching of regulatory

focus and information framework has an impact on the persuasive effect of consumers. When exploring the relationship between sales promotion and consumers' characteristics, Shi *et al.* (2013) found that in the situation of gift promotion, promotion focus consumers has higher purchase intention; in the situation of price promotion, prevention focus consumers have higher purchase intention. Therefore, this paper will focus on the matching effect of different characteristics regulatory focus consumers in the face of different promotional information, and refer to the existing research to divide consumers into promotion focus consumers and prevention focus consumers.

RESEARCH HYPOTHESIS

Price promotion and gift promotion are two typical representatives of price-oriented promotion and non-price-oriented promotion respectively (Liu *et al.*, 2012), among which donation promotion is a special form of gift promotion. Price promotion emphasizes practical benefits for buyers themselves, while donation promotion emphasizes practical benefits for sellers or social undertakings other than buyers. Previous studies have found that price promotion can bring more benefits to sellers than gift promotion. In the sales promotion, promotion revenue is the most intuitive perception of consumers. Combined with the rational "economic man" point of view, compared with the reputation value of donation promotion to consumer, the reduction of product price will make consumers feel higher cost saving and more likely to stimulate consumers' impulsive buying behavior. Based on this, this research proposes:

Hypothesis 1: Compared with the donation promotion, price promotion is more likely to stimulate consumers to produce impulsive buying behavior.

Face awareness is a relatively stable and long-term personality characteristic, which is closely related to promotion patterns. Since face depends on others' views on themselves, and the donation promotion is a cognitive process of connecting with other groups in the society through donation and other ways, so as to enhance the individual image of consumers (Arora & Henderson, 2007), Obviously, in the situation of donation promotion, high face awareness consumers are more likely to produce impulsive buying behavior in order to improve their image. In the situation of price promotion, consumers can perceive the value of money and reputation at the same time. Under the joint effect of these two values, the effect of face awareness on consumers' impulsive buying behavior may not be significant. Based on this, this research proposes the following hypotheses:

Hypothesis 2: There is a significant difference in the possibility of impulse buying behavior between high face awareness consumers and low face awareness consumers.

Hypothesis 2a: The interaction between promotion patterns and face awareness has a significant impact on consumers' impulsive buying behavior

Hypothesis 2b: In the situation of price promotion, there is no significant difference in the possibility of producing impulse buying behavior between high face awareness consumers and low face awareness consumers.

Hypothesis 2c: In the situation of donation promotion, consumers with high face awareness are more likely to produce impulsive buying behavior than those with low face awareness.

By exploring the regulatory focus research in the consumer field, we find that: regulatory focus has an impact on consumers' decision-making from two paths. One is that regulatory focus directly affects consumer decision-making as an independent variable. For example, consumer with different characteristics of regulatory focus shows different intentions in the process of purchasing decision-making. The other is that regulatory focus and other factors jointly influence consumer decision-making. For example, some scholars proposed that consumers with two different focuses, promotion and prevention, can produce different results when faced with different promotional information. Scholars also pointed out that the interaction between regulatory focus and information framework significantly affects consumers' purchase intention. Combined with the previous research results on price promotion and gift promotion, this paper puts forward the promotion framework of this research by sorting out and summarizing the concepts of existing literature: the price promotion situation is matched with the prevention focus consumers, and the donation promotion situation is matched with the promotion focus consumers. Based on this, this paper puts forward the following hypothesis:

Hypothesis 3: There is a significant difference between the possibility of promotion focus consumers and prevention focus consumers to produce impulsive buying behavior.

Hypothesis 3a: The interaction of promotion patterns and regulatory focus has a significant impact on consumers' impulsive buying behavior.

Hypothesis 3b: In the situation of price promotion, prevention focus consumers are more likely to produce impulsive buying behaviors than promotion focus consumers.

Hypothesis 3c: In the situation of donation promotion, promotion focus consumers are more likely to produce impulsive buying behavior than prevention focus consumers.

To sum up, on the basis of sales promotion stimulus, this paper explores the influence of consumers' psychological level - face awareness and personality traits - regulatory focus on consumers' impulsive buying behavior under the two situations of price promotion and donation promotion. According to the relationship and hypothesis between the variables, the relevant theoretical model framework is constructed, as shown in Fig 1.

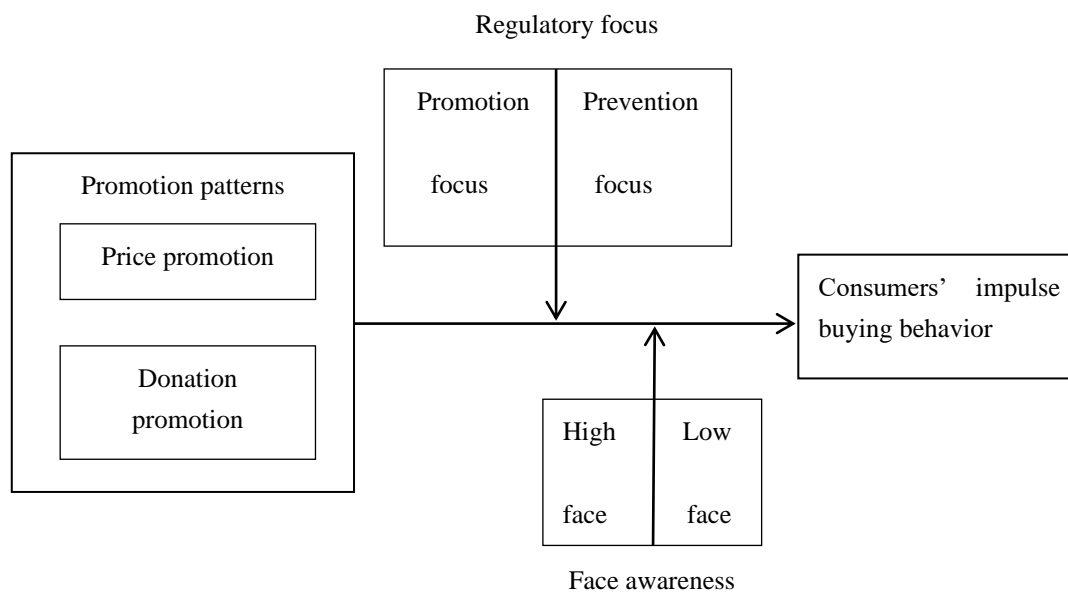

Figure 1: Theoretical framework of the model

RESEARCH METHODOLOGY

Data Collecting

This study used 2 (promotion patterns: price promotion, donation promotion) x 2 (face awareness: high face, low face) x 2 (regulatory focus: promotion focus, prevention focus) three factor experiment design. The inter group design was adopted for promotion patterns, and intra group design was used for face awareness and regulatory focus. Two situational questionnaires were formed. In order to ensure the randomness of the questionnaire survey, the subjects were randomly assigned to one of the two groups of situation questionnaires, and were asked to respond to the options in the questionnaire concerning promotion patterns, face awareness and regulatory focus after reading the description of the situation. The respondents are mainly college students, because college students are sensitive to sales promotion and they are the main consumer group of online shopping (Zeng, Hao & Yu, 2018). However, not all college students can be regarded as qualified research objects, so in order to exclude samples such as "have not done online shopping" and "have not participated in sales promotion", this study set questions such as "have done online shopping" and "have participated in sales promotion" at the end of the questionnaire for screening. In addition, considering that the participating individuals will be affected by different brands, this research adopts a fuzzy treatment on the brands.

In the survey of this study, based on the review of the existing literature, a total of 400 questionnaires were distributed in electronic and paper forms, and questionnaires filled in by consumers who have not done online shopping or participated in sales promotion and whose answers are incomplete are excluded. Finally, 323 valid questionnaires were obtained, and the effective recovery rate was 80.8%. Referring to the practices of existing scholars (Palazon & Delgado-Ballester, 2011), this paper chooses coffee as the target product because coffee products are often purchased by consumers, especially college students. At the same time, in real life, coffee sellers often use sales promotion to stimulate consumers' purchase, and male consumers and female consumers have no special preference for coffee products. It is a product that does not rely on price to shape their own image, which can bring benefits to consumers and stimulate consumers' interest. Therefore, this study takes coffee as the goal product. Finally, after all data collection is completed, the final valid data will be imported into the software for analysis and verification.

Measures

In this study, the manipulation of independent variable promotion patterns mainly refers to the research of Nunes *et al.* (2003). The product value is consistent, and two forms of price promotion and donation promotion are selected. Experimental situation: Suppose the seller is promoting coffee products. Under the price promotion situation, the coffee price is reduced by 25 yuan. Under the situation of donation promotion, buy coffee and give away one public welfare product (value: 25 yuan). For the setting and measurement of variable face awareness, we mainly refer to the research of Chan (2009) and Yu *et al.* (2019), including "I care about the attitude of others towards me", "I care about the praise and criticism of others to me", etc. For the measurement of variable regulatory focus, academia has formed a set of relatively mature scales. The scale in this study mainly refers to the regulatory focus scale proposed by Haws *et al.* (2010) which has good reliability and validity. Consumer impulse buying behavior as dependent variable was mainly measured according to the study of Dholakia (2000) with questions such as "I often buy things that I do not intend to buy online" and "I almost never buy goods that I do not plan to buy online". The reliability coefficients of all latent variables in the scale are all over 0.7, so the values obtained from the measured items can be averaged (Ryu & Feick, 2007). In this experiment, except for the general options, the remaining questions were measured by Likert scale of 7, in which 1 means "extremely disagree" and 7 means "extremely agree". At the end of the questionnaire,

demographic variables were measured, including income, age, gender, education experience, etc.

RESULTS

Manipulation Test

Spss22.0 software was used as the basic analysis tool for all data analysis in experiment 1. First of all, we tested whether the manipulation of promotion patterns was successful by measuring consumers' attitudes towards promotion patterns. The results showed that the score of price promotion ($M_{\text{price promotion}} = 5.22$) was significantly higher than that of donation promotion ($M_{\text{donation promotion}} = 4.60$) ($F = 28.012, P < 0.001$), the manipulation was successful. Then, referring to the practice of Wirtz (2002) and Zeng, Hao and Yu (2018), this study calculated the mean value of the items of face awareness, took 4 as the critical value, regarded those who score higher than 4 in the questionnaire as high face awareness consumers, used "1" to indicate, regarded those equal to or less than 4 as low face awareness consumers, and used "0" to express them. After the change of face awareness, this paper conducted the manipulation test, and found that the average score of consumers with high face awareness ($M_{\text{high face awareness}} = 5.31$) was significantly higher than that of consumers with low face awareness ($M_{\text{low face awareness}} = 3.04$) ($F = 498.115, P < 0.001$), so the manipulation was successful. Finally, for the measurement of regulatory focus, we refer to Li *et al.*'s research (2017). First, the average scores of the subjects in the questionnaire in the two dimensions of promotion focus and prevention focus were taken as the difference, and the median of the difference was calculated to be 1. Then we regarded the subjects who were greater than or equal to 1 as the promotion focus consumers and those less than 1 as the prevention focus consumers. After the completion of the regulatory focus group, the manipulation test was conducted. It was found that there was a significant difference in the mean value of regulatory focus between the promotion focus consumer group and the prevention focus consumer group ($F = 57.245, P < 0.001$), which indicated that the manipulation was successful.

Hypothesis Test

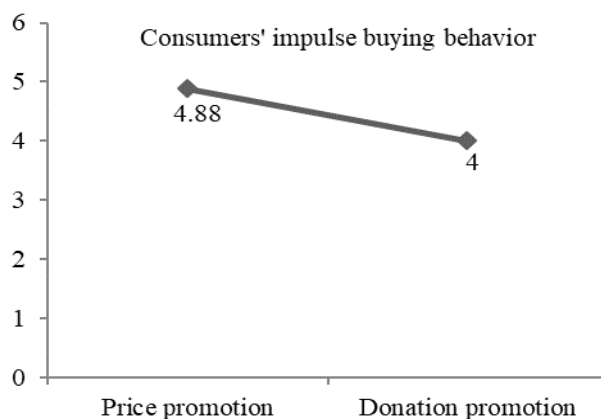

Figure 2: The effect of promotion patterns on consumers' impulsive buying behavior

Through the analysis of variance of promotion patterns, it is found that compared with the situation of donation promotion, consumers are more likely to produce impulsive buying behavior under the situation of price promotion ($M_{\text{price promotion}} = 4.88$, $M_{\text{donation promotion}} = 4.00$; $F = 48.801, P < 0.001$), the results also showed that the difference in the likelihood of consumers' impulsive buying behaviors was statistically significant under the two situations of price promotion and donation promotion. Hypothesis 1 holds, the results are shown in Fig 2.

Similarly, we conducted ANOVA on face awareness and regulatory focus, and found that there were significant differences between high face awareness consumers and low face awareness consumers in the possibility of impulsive buying behaviors ($F = 23.856, P < 0.001$). There is also a significant difference between the possibility of impulsive buying behavior of consumers who have promotion focus and that of consumers who have prevention focus ($F = 16.397, P < 0.001$). Suppose H2 and H3 hold.

Then, we test the interaction of variables in this study. First, we analyze the interaction between promotion patterns and face awareness. The results are shown in Table 1, the interaction between promotion patterns and face awareness on consumers' impulsive buying behavior is significant, and hypothesis H2a holds.

Table 1: Analysis of variance between promotion patterns and face awareness on consumers' impulse buying behavior

Source	Dependent variable	Type III sum of squares	df	Mean square	F	Sig
Promotion patterns* Face awareness	Consumers' impulse buying behavior	4.641	1	4.642	6.698	.009

Next, we divided the promotion patterns into two situations: the price promotion and donation promotion. The results show that there is no significant difference between the possibility of impulsive buying behavior of consumers with high face awareness and that of consumers with low face awareness under the price promotion ($M_{\text{high face awareness consumers}} = 4.09$, $M_{\text{low face}}$

awareness consumers = 3.86; $F = 2.477$, $P = 0.118$). However, in the situation of donation promotion, consumers with high face awareness ($M_{\text{high face awareness consumers' impulsive buying behavior}} = 4.34$) were more likely to produce impulsive buying behavior than those with low face awareness ($M_{\text{low face awareness consumers' impulsive buying behavior}} = 3.62$) ($F = 24.254$, $P < 0.001$). H2b and H2c hold, the results are shown in Fig 3.

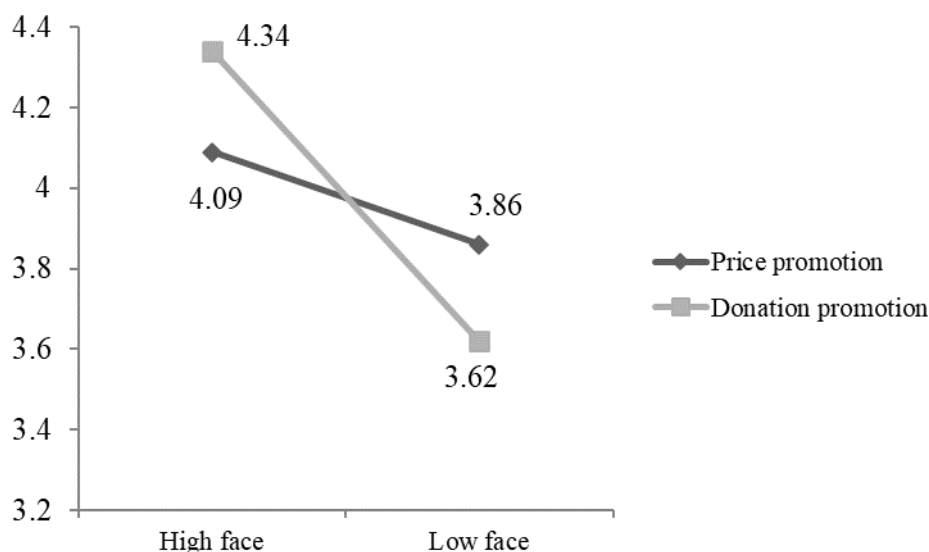

Figure 3: The influence of promotion patterns and face awareness on consumers' impulsive buying behavior

Then, we analyze the interaction between promotion patterns and regulatory focus. The results are shown in Table 2. The interaction between promotion patterns and regulatory focus is significant, H3a holds.

Table 2: Analysis of variance between promotion patterns and regulatory focus on impulse buying behavior of consumers

Source	Dependent variable	Type III sum of squares	df	Mean square	F	Sig
Promotion patterns*	Consumers' impulse buying behavior	50.283	1	50.283	76.658	.000
Regulatory focus						

Next, we also divide the promotion patterns into two situations: price promotion and donation promotion. The results show that in the situation of price promotion, prevention focus consumers ($M_{\text{prevention focus consumers}} = 4.15$) are more likely to produce impulsive buying behavior than promotion focus consumption ($M_{\text{promotion focus consumers}} = 3.81$) ($F = 6.702$, $P = 0.011$, $P < 0.05$), which is consistent with our hypothesis that prevention focus consumers are more inclined to avoid risks, H3b holds. However, in the situation of donation promotion, the results show that prevention focus consumers ($M_{\text{prevention focus consumers}} = 4.09$) are more likely to produce impulsive buying behavior than promotion focus consumers ($M_{\text{promotion focus consumers}} = 3.65$) ($F = 9.489$, $P = 0.002$); this is contrary to our hypothesis, that is, H3c does not hold. One reason may be that prevention focus consumers imagine the expected target status as responsibility to a greater extent, and participation in donation promotion activities can be seen as a manifestation of consumers' fulfillment of responsibility. Another reason may be that other personal characteristics of consumers play a role in the influence of promotion patterns and regulatory focus on consumer impulsive buying behavior. Scholars such as Duan *et al.* (2018) have proposed that for consumers who rely on self-construction, prevention focus information is more convincing, so they are more inclined to donate promotion. Future research further explore the factors that lead to the hypothesis failure. The results are shown in Fig 4.

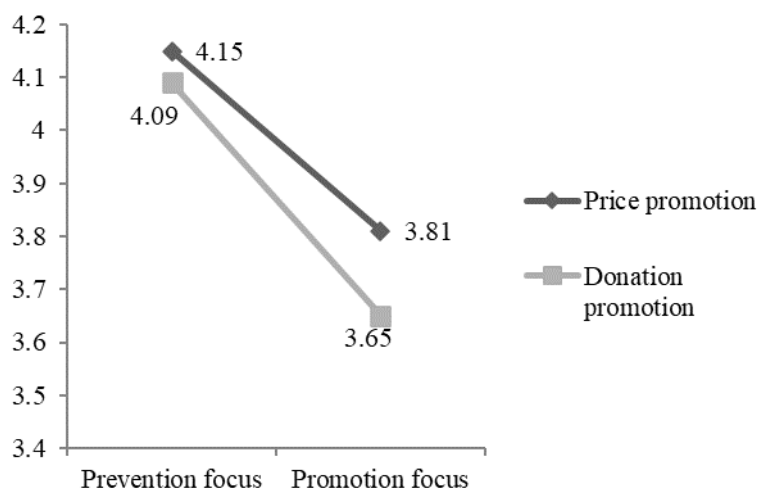

Figure 4: The influence of promotion patterns and regulatory focus on consumers' impulsive buying behavior

CONCLUSION

By using the method of situational experiment, this paper reveals the influence mechanism of promotion patterns, face awareness and regulatory focus on consumers' impulsive buying behavior.

The experimental results show that price promotion is more likely to lead to impulsive buying behavior than donation promotion, which is consistent with the research results of Zeng and Hao (2015). In the situation of price promotion, there is no significant difference between the impulsive buying behavior of high face awareness consumers and that of low face awareness consumers. This may be due to the fact that consumers can perceive the value of money and reputation in the situation of the price promotion, and the inconsistency between the two value motives triggers consumers' entanglement psychology, which leads to insignificant differences in the possibility of impulsive buying behavior between consumers with high face awareness and consumers with low face awareness. In the situation of donation promotion, consumers with high face awareness are more likely to produce impulsive buying behavior than those with low face awareness. This is because high face awareness consumers pay more attention to self-image management, and the prosocial nature of donation promotion can improve customer image. Therefore, consumers with high face awareness are more likely to produce impulsive buying behavior in the situation of donation promotion. However, in both price promotion and donation promotion, prevention focus consumers are more likely to produce impulsive buying behaviors than the promotion focus consumers. This conclusion is consistent with the content that different regulatory focus consumers pay attention to.

Managerial Implication

The conclusion of this study provides guidance for seller promotion strategy. First of all, in terms of the impact of face awareness on consumers' impulsive buying behavior, sellers that launch sales promotion of donation should pay more attention to consumers with high face awareness, and improve their intention to participate in sales promotion of donation by stimulating their face awareness. Secondly, in terms of communication strategies, sellers can use the advantage of donation promotion to maintain their image to induce consumers to purchase, such as publicizing the benefits of participating in sales promotion of donation for others, making consumers feel the expectations of people around them, so as to stimulate consumers' awareness of face rather than simply emphasizing product functions. Then, in the face of price promotion and donation promotion, from the social point of view, it is suggested to choose the promotion patterns of donation, and sellers should pay attention to the selection of gifts in marketing practice. Finally, sellers can carry out bundling marketing to a certain extent. Compared with price promotions, such bundled marketing activities of donation promotion not only make sellers obtain profits, but also support the development of poor areas, which is conducive to the long-term development of sellers.

Limitation and Suggestion

There are also some limitations in this study. Firstly, this study mainly analyzes the impact of price promotion and donation promotion on consumers' impulsive buying behavior, but does not explore other types of promotion patterns. In the future, we can conduct a more comprehensive and in-depth study in order to improve the universality of the conclusion. Secondly, this paper only compares the difference between price promotion and donation promotion. As a special form of gift promotion, whether some conclusions can be directly applied to general gift promotion needs to be further verified. In future research, we can compare the two promotion patterns to reveal their commonness and characteristics. Thirdly, this paper chooses coffee as the target product. It is a product that does not rely on increasing the price to shape its image. However, for the products that are easily affected by price changes, how the price of products affects consumers' impulse buying behavior is not explored in this paper. Future research can make targeted analysis on this.

REFERENCES

- [1] Aaker, J. L., & Lee, A. Y. (2001). "I" seek pleasures and "we" avoid pains: The role of self-regulatory goals in information processing and persuasion. *Journal of Consumer Research*, 28(1), 33-49. doi:10.1086/321946
- [2] Arora, N., & Henderson, T. (2007). Embedded premium promotion: Why it works and how to make it more effective. *Marketing Science*, 26(4), 514-531. doi:10.1287/mksc.1060.0247
- [3] Bao, Y., Zhou, K. Z., & Su, C. (2003). Face consciousness and risk aversion: do they affect consumer decision-making? *Psychology & Marketing*, 20(8), 733-755. doi: 10.1002/mar.10094.
- [4] Campbell, L., & Diamond, W. D.(1990). Framing and sales promotions: The characteristics of a "good deal". *Journal of Consumer Marketing*, 7(4), 25–31. doi: 10.1108/EUM0000000002586
- [5] Chan, H., Wan, L. C., & Sin, L. Y. (2009). The contrasting effects of culture on consumer tolerance: Interpersonal face and impersonal fate. *Journal of Consumer Research*, 36(2), 292-304. doi: 10.1086/597329
- [6] Chunling, Y., Xiaodong, Z., Xia, W., & Yifei, Z. (2019). Face Consciousness and Green Buying Intention: The Moderating Effect of Consumption Context and Mediating Effect of Price. *Management Review*, 31 (11), 139.
- [7] Dholakia, U. M. (2000). Temptation and resistance: An integrated model of consumption impulse formation and enactment. *Psychology & Marketing*, 17(11), 955-982. doi: 10.1002/1520-6793(200011)17:113.0.CO;2-J
- [8] Duan, S., Wang, D.H., Yao, T. & Qiu, Q. (2018). The influence of self-construction on the consumers' promotions preference. *Journal of Management Science*, 31(6), 128-144. Retrieved from http://glkx.hit.edu.cn/glkxcn/ch/reader/view_abstract.aspx?file_no=201708102&flag=1
- [9] Grant, A. M., & Mayer, D. M. (2009). Good soldiers and good actors: prosocial and impression management motives as interactive predictors of affiliative citizenship behaviors. *Journal of Applied Psychology*, 94(4), 900-912. doi: 10.1037/a0013770
- [10] Hao, L., Gao, C., & Jia, J. (2008). A case study on the impact of the way of the price discount presentation on the effectiveness of sales promotion. *Management World*, 10, 106-126.
- [11] Haws, K. L., Dholakia, U. M., & Bearden, W. O. (2010). An assessment of chronic regulatory focus measures. *Journal of Marketing Research*, 47(5), 967-982.
- [12] Kalwani, M. U., & Yim, C. K. (1992). Consumer price and promotion expectations: An experimental study. *Journal of Marketing Research*, 29(1), 90-100. doi: 10.2307/3172495
- [13] Kotler, P. & Keller, K.L. (2009). *Marketing Management*. Upper Saddle River, N.J. : Pearson Prentice-Hall.
- [14] Li, Q.G., Zhao X.H., Yu M.Y. (2017). Research on the influence of online review information structure and consumer regulation focus on the perceived usefulness of reviews. *Journal of Shanghai Jiaotong University (Philosophy and Social Sciences)*, 25(004):87-96. doi: 10.13806/j.cnki.issn 1008-7095.2017.04.010
- [15] Li, Y. (2015). Impact of impulsive buying behavior on postimpulsive buying satisfaction. *Social Behavior and Personality: An International Journal*, 43 (2), 339-351.
- [16] Liu, H. Y., Li, A. M., Wang, H. Z., & Wei, H. Y. (2012). The effect of promotion types on consumers' purchase decisions: From the perspective of construal level theory. *Acta Psychologica Sinica*, 44 (8), 1100-1113.
- [17] Luo, X., Homburg, C., & Wieseke, J. (2010). Customer satisfaction, analyst stock recommendations, and firm value. *Journal of Marketing Research*, 47(6), 1041-1058. doi: 10.1509/jmkr.47.6.1041
- [18] Mela, C. F., Gupta, S., & Lehmann, D. R. (1997). The long-term impact of promotion and advertising on consumer brand choice. *Journal of Marketing Research*, 34(2), 248-261. doi: 10.1177/002224379703400205
- [19] Mishra, A., & Mishra, H. (2010). We are what we consume: The influence of food consumption on impulsive choice. *Journal of Marketing Research*, 47(6), 1129-1137. doi: 10.1509/jmkr.47.6.1129
- [20] Nunes, J. C., & Park, C. W. (2003). Incommensurate resources: Not just more of the same. *Journal of Marketing Research*, 40(1), 26-38.
- [21] Palazon, M., & Delgado-Ballester, E. (2011). The expected benefit as determinant of deal-prone consumers' response to sales promotions. *Journal of Retailing and Consumer Services*, 18(6), 542-547. doi: 10.1016/j.jretconser.2011.07.004
- [22] Rook, D. W. (1987). The buying impulse. *Journal of Consumer Research*, 14(2), 189-199. doi: 10.1086/209105
- [23] Ryu, G., & Feick, L. (2007). A penny for your thoughts: Referral reward programs and referral likelihood. *Journal of Marketing*, 71(1), 84-94. doi: 10.1016/j.ejor.2011.05.042
- [24] Simmons, S. A., Carr, J. C., Hsu, D. K., & Shu, C. (2016). The regulatory fit of serial entrepreneurship intentions. *Applied Psychology*, 65(3), 605-627. doi: 10.1111/apps.12070
- [25] Sohn, H. K., & Lee, T. J. (2017). Tourists' impulse buying behavior at duty-free shops: The moderating effects of time pressure and shopping involvement. *Journal of Travel & Tourism Marketing*, 34(3), 341-356. doi: 10.1080/10548408.2016.1170650
- [26] Sun, Y., Li, S. & Wang, Y. (2007). A review of psychological and behavioral research on promotion. *Chinese Journal of Ergonomics*, (4), 48-50+54. doi: 10.3969/j.issn.1006-8309.2007.04.015
- [27] Wan, L. C., Poon, P. S., & Yu, C. (2016). Consumer reactions to corporate social responsibility brands: the role of face concern. *Journal of Consumer Marketing*, 33(1), 52-60. doi: 10.1108/JCM-03-2013-0493
- [28] Wang, H. & Yang, F.L. (2014). Research on the Impact of Online full sales promotion on impulsive buying behavior. *Journal of Northeast Agricultural University (Social Science Edition)*, (6): 8-14. doi: 10.3969/j.issn.1672-3805.2014.06.002
- [29] Wirtz, J., & Chew, P. (2002). The effects of incentives, deal proneness, satisfaction and tie strength on word-of-mouth behaviour. *International Journal of Service Industry Management*, 13(2), 141-162.
- [30] Zeng, H., & Hao, L.G. (2015). The impact of the way of promotion presentation on customer brand loyalty. *Soft Science*,

- (5), 25.
- [31] Zeng, H., Hao, L.G. & Yu, Z.P. (2018). Can Reward Change Consumers' Online Reviews? —The Impact of Reward Program on E-word of Mouth. *Management Review*, 30 (2), 117-126 http://journal05.magtech.org.cn/jweb_glp/EN/Y2018/V30/I2/117. (in Chinese).
- [32] Zhang, L., Fan, T.T. & Wang, W.B. (2007). Price perception and purchasing intention under different discount presentations. *Nankai Business Review*, 3, 19-28. http://en.cnki.com.cn/Article_en/CJFDTotal-LKGP200703004.htm
- [33] Zhang, X. A., Cao, Q., & Grigoriou, N. (2011). Consciousness of social face: The development and validation of a scale measuring desire to gain face versus fear of losing face. *The Journal of Social Psychology*, 151(2), 129-149.

Impact of Corporate Social Responsibility on Consumers' Purchase Behavior in the E-commerce Environment

(Work in Progress)

Li Xiaolin, Sichuan Agricultural University, China, 57929606@qq.com

Huang Dunhu*, Sichuan Agricultural University, China, 1287301356@qq.com

Guo Mengqian, Sichuan Agricultural University, China, 1766457224@qq.com

ABSTRACT

The development of the Internet has promoted the prosperity of e-commerce, and has a great impact on today's consumers' consumption concepts. For e-commerce platform, this is not only an opportunity, but also a challenge. If we gain advantages in the fierce competition environment, it will become the leader in the e-commerce environment. Corporate social responsibility has a significant impact on the operation and development of enterprises. With the increasing attention of society to corporate social responsibility, social responsibility is gradually becoming an important factor in determining the value of enterprises, which is also the case for e-commerce platforms. In order to provide a new way for the development of e-commerce platform, this paper analyzes the impact of corporate social responsibility on consumer purchasing behavior, and discusses the significance of corporate social responsibility on e-commerce platform.

Keywords: E-commerce, corporate social responsibility, consumer sentiment, consumer behavior.

*Corresponding author

INTRODUCTION

In recent years, with the continuous development and popularization of the Internet, e-commerce platforms are becoming more and more mature, and the competition between platforms is becoming more and more fierce. How to stand out in this fierce competition is the focus of all platforms. The success of e-commerce platform depends not only on consumers' favor for their products and services, but also on the social responsibility of enterprises for many consumers. Ren is also a point that cannot be ignored, such as Pinduoduo and Taobao to help solve the problem of unsalable agricultural products; Jingdong launched the "Love Charity Sale" activities, which are all examples of e-commerce platforms actively taking social responsibility. Corporate social responsibility can not only enhance the bottom line profitability of e-commerce platform, but also provide competitive advantage.

In this paper, we believe that consumers' perception of corporate social responsibility will have an impact on their emotional bias. In this case, no matter whether consumers are benefited or not, they will think it is beneficial to the society, so they will have a positive emotion, and this feeling will also affect consumers' purchasing behavior, and consumers will purchase more actively with social responsibility. However, consumers' perception of product quality and service experience of e-commerce platform may affect the effect of corporate social responsibility. At present, scholars' research perspective on corporate social responsibility has not focused on the e-commerce platform, and the development of e-commerce is in a new stage. In view of this, this study, starting from consumer perception and experience, explores whether the e-commerce platform can effectively influence consumers' purchasing behavior through social responsibility activities, and in the context of e-commerce, corporate social responsibility will be affected by some factors, the influence of corporate social responsibility on consumers is weakened. The research results will help the e-commerce platform to understand the importance of social responsibility and how social responsibility affects consumers' purchase behavior, and finally provide a new direction in competition.

THEORETICAL BASIS AND RESEARCH HYPOTHESIS

This study examines the impact of corporate social responsibility on consumers' purchase. It examines the relationship between consumers' emotion and purchase intention when e-commerce platforms participate in social activities and undertake social responsibility, and whether consumers' emotion is affected by their whole shopping experience, and whether this shopping experience weakens corporate social responsibility effect. In this study, we focus on consumers' emotion and experience after perceived corporate social responsibility, and the process of behavior change.

Consumers in E-commerce Environment

The competition of e-commerce industry is becoming more and more fierce. The major e-commerce platforms are also gradually focusing on the cities below the third tier. The development speed has also changed from rapid development to stable development. The market share is getting smaller and smaller, and new markets and flows are needed. The development of the Internet has gradually changed the consumer psychology of customers, and quality is no longer the only standard for purchasing. Under this environment, the behavior of consumers can be summarized as follows: 1. Segmentation of the consumer market; 2. Service demand becoming the mainstream; 3. The expansion of the scope of choice and the emotional

behavior of consumers (Liu, 2015). However, it is more and more difficult to develop the market and optimize the service, so the sensibility of consumers has become a direction of our thinking. Through the literature, we find that consumers pay more and more attention to social problems, such as environmental pollution, unsalable agricultural products, etc. However, in order to attract consumers' attention through these contents, the social responsibility of enterprises becomes more and more important. On the one hand, such a theme will attract consumers. On the other hand, it will also affect consumers' purchase behavior to a great extent. This paper focuses on the latter, mainly on the impact on consumer behavior. The era of e-commerce is known as the "customer-centered era" because it requires us to carry out various activities around this center. We should take into account any factors related to customers. Sometimes, some subtle factors will determine success or failure.

Corporate Social Responsibility

Corporate social responsibility refers to that enterprises should be responsible for the whole society while creating profits. It can make consumers have positive evaluation of enterprises and then turn into positive evaluation of products, which will naturally affect their purchase intention and behavior. In the past, scholars have carried out a lot of research on this, and found and discussed the factors affecting corporate social responsibility and the impact of practicing corporate social responsibility. For example, if enterprises undertake social responsibility, consumers will feel grateful (Kim & Park, 2020). At present, corporate social responsibility is also regarded as a strategic goal to achieve. At the same time, the strategy of changing the world requires enterprises to change the idea of taking profit as the only goal, emphasizing the attention to human value in the production process, and the contribution to the environment, consumers and society. Some scholars take the concept of corporate social responsibility rooted in the theory of sustainable development, so as to bring social, economic and environmental issues into the operation of enterprises (Hardjono & Marrewijk, 2001). Some scholars review the relevant literature on consumer behavior of corporate social responsibility and find that the relationship between them is not a simple indication (Green & Peloza, 2015), that is to say, some variables can play a mediating and regulating role. Consumer integrity reduces the impact of corporate social responsibility on the degree of admiration. Therefore, for consumers with higher integrity, the relationship is stronger, while consumers with lower integrity are weaker (Castro-González, Bande & Fernández-Ferrín, 2019). For example, launching a corporate social responsibility campaign will generate more favorable consumer attitudes towards the company and its products, leading to higher willingness to buy (Sen, Du & Bhattacharya, 2016). Therefore, the hypothesis is put forward:

H1: corporate social responsibility has a positive relationship with consumers' purchase behavior.

Gratitude Inspired by Corporate Social Responsibility

Consumers' gratitude

As a form of emotion, emotion is an important factor affecting consumers' purchase intention. Through the literature, we know that emotions are divided into positive and negative, and even contradictory emotions (Williams, Bannister, & Arribas-Ayllon, 2015). Positive and positive emotions have attracted the attention of psychologists. The enthusiasm in corporate social responsibility activities can make consumers have a positive view of the companies that implement these behaviors. Extensive research shows that CSR efforts of companies can lead to various positive consumer reactions. A large number of literature studies has found that corporate social responsibility has a specific impact on consumer cognition (Park, Kim, & Kwon, 2017), such as loyalty and satisfaction. In this paper, the practice of corporate social responsibility organizations aims to improve social, environmental or economic conditions. We believe that when enterprises carry out corporate social responsibility activities, they will reflect the corporate ethics, and attract the attention of consumers. Consumers will think that corporate social responsibility activities are positive, and will produce a positive emotion, and this emotion is actually coming from the recognition of enterprises, when consumers perceive that the social responsibility activities participated by enterprises are beneficial to the society, even if they have no actual benefits to themselves, they will support and thank them for making the society better (Romani, Grappi, & Bagozzi, 2013). In this paper, we call this positive emotion "gratitude", which not only reflects the consumer's sense of identity, but also reflects that the consumer's response to corporate social responsibility is related to certain values and orientations. Combing the literature, we find that in the current e-commerce environment, through a series of social responsibility activities, each e-commerce platform can get good comments and word-of-mouth from consumers and the influence of emotion is the most important. Therefore, the hypothesis is put forward:

H2: when enterprises practice social responsibility, consumers will feel grateful.

The influence of gratitude on consumers' purchase intention

Gratitude is a kind of prosocial emotion, because people who experience gratitude think that they are the beneficiaries of other people's praiseworthy behavior (Duprey, McKee, & O'Neal, 2020), so gratitude can transform other positive emotions into other forms of prosocial behavior (Bartlett & DeSteno, 2006). Therefore, when the e-commerce platform is doing something beneficial to the society, consumers may appreciate their contributions to the society, and support and reward them in some other ways, such as purchasing products with relevant social responsibility or producing positive evaluation, and such gratitude will affect consumers' perception of negative information of the e-commerce platform. Gratitude can not only bring consumers a good impression on the e-commerce platform, but also promote the transformation of this goodwill into behavioral impulse. For example, if the platform holds an activity related to social responsibility, consumers will feel grateful for this kind of activity which is beneficial to the society, and then this gratitude will extend to consumers' cognition of the whole corporate image, products and services. As a positive positive emotion, gratitude will also make consumers have a more positive cognition of the enterprise, thus arousing consumers' purchase willingness. Experience shows that the judgment of consumers'

dislike is accompanied by the judgment process of liking, otherwise, it is not. This shows that people should consider the reason of liking a thing when considering whether they like it or not (Xie, Bagozzi & Grønhaug, 2018). That is to say, for the e-commerce platform, the gratitude of consumers aroused by their implementation of corporate social responsibility plan may become an important factor for consumers to evaluate them, and the love for an e-commerce platform will naturally lead to the promotion of purchase intention. Therefore, the hypothesis is put forward:

H3: consumers' gratitude positively influences purchase intention.

Customer Experience

Customer experience has always been an important research content in the field of marketing, because it can let consumers feel the value of products and services most directly (Novak, Hoffman, & Yung, 2000). In today's e-commerce platform, customer experience is affected by a variety of factors, such as the interaction of cross-border e-commerce websites, category diversity and convenience, which will affect customers' online shopping experience (Kwak & Yoo, 2014), but at the same time, these factors are also important factors to increase the income of e-commerce platforms. In this paper, customer experience is simply interpreted as platform experience and product experience. The form of experience is often divided into five types: sensory experience, emotional experience, thinking experience, action experience and related experience (Hoyer, Kroschke, & Schmitt, 2020). In addition, the participation of corporate social responsibility will enhance consumers' trust in enterprises, and the quality of platform experience and product experience will affect consumers' trust in enterprises (Castro-González, Bande, & Fernández-Ferrín, 2019). The quality of customer experience will affect gratitude, good experience will strengthen the emotion of "gratitude" and improve the influence of "gratitude" on purchase intention, while bad experience will weaken the influence of positive emotion of gratitude on purchase intention, and ultimately improve or reduce the purchase intention of consumers. For example, when customers get a good experience, their sense of identity will be strengthened, they will recognize the value concept and orientation of the enterprise, recognize the behavior of the enterprise, and will feel that the enterprise is beneficial to the society. This emotion gratitude will also be stimulated to a greater extent, so the impact on the purchase intention will be more profound. On the contrary, if the customer experience is poor, it will affect consumers' recognition of enterprises from many aspects, such as reducing trust, thus weakening the "gratitude" of consumers caused by enterprises in the practice of social responsibility, which will naturally have an impact on the purchase intention. Here, the main purpose of this paper is to express that the quality of customer experience will affect the degree of consumers' gratitude to purchase intention. Therefore, the hypothesis is put forward:

H4: customer experience plays a moderating role in consumer gratitude and purchase intention

Purchase Intention

Willingness represents the degree to which an individual intends to perform a specific behavior. In Information Systems Science, the significant effect of willingness on behavior has long been proposed and confirmed. We believe that in the e-commerce environment, consumers' purchase intention will have a positive impact on subsequent purchase behavior. Therefore, the hypothesis is put forward:

H5: purchase intention positively affects purchase behavior

RESEARCH MODEL

Through literature review, this study proposes a conceptual model based on social identity theory and attribution theory. Social identity theory was first proposed by Tajfel, mainly used to explain group behavior. Social theory is established by classification, identification and comparison. In the field of consumers, social identity theory is also widely used. In the process of consumption, consumers need to meet the needs of self-definition. With the development and progress of society, when consumers purchase products, they not only pay attention to whether the products can meet their actual needs, but also pay attention to the characteristics of enterprises. Corporate social responsibility has gradually become an important way for consumers to understand corporate culture and values. As a form of moral norms, it can also represent a positive corporate image. When consumers perceive that the enterprise is practicing social responsibility, good corporate image is also perceived, and their sense of identity with the enterprise is strengthened. Therefore, they will have a stronger desire to purchase the products of the enterprise. According to attribution theory, people usually try to explain social behavior consciously or unconsciously. When consumers evaluate corporate social responsibility behavior, they will infer the motivation behind their behavior. However, corporate social responsibility behavior belongs to a kind of behavior in the moral category, and consumers often think it is positive. Therefore, they will perceive that corporate social responsibility is beneficial to the society. They will recognize this behavior and form a positive emotion - "gratitude". The model of this paper is shown in Figure 1.

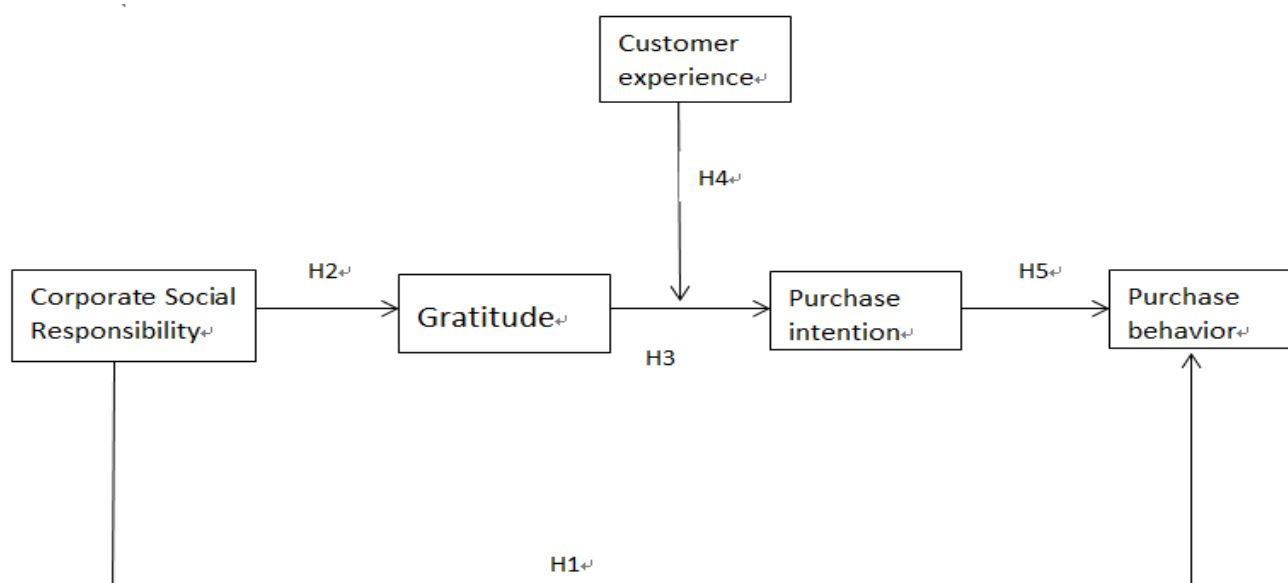

Figure 1: Research Model.

RESEARCH DESIGN

This study explores the impact of corporate social responsibility on consumer behavior from the perspective of e-commerce environment. Therefore, this paper adopts the way of questionnaire to conduct a series of research. The questionnaire includes two parts: the questionnaire and the questionnaire. The questionnaire was produced and distributed through the "questionnaire star" platform.

Variable Measurement

The scales used in this study are all based on the developed scales and modified appropriately on the existing ones. The specific scales used are as follows: (1) the scale of corporate social responsibility mainly refers to the scale developed by Kim and Park (2020) and their related scales. In this paper, the specific measurement is modified according to the required content, and finally, four measurement items are sorted out. For example, "the role of enterprises in our society has gone beyond just a generation.". (2) Gratitude refers to Ohanian's scale (1990), which has been widely used. Finally, three measurement items are sorted out, such as "I am grateful for the efforts made by the platform to contribute to society." (3) Purchase intention refers to the scale of Chen (2020), etc., which is sorted out and modified, and finally gives four items, such as "I am more willing to try to buy new products and services launched by the platform", "the platform is my first choice to purchase such products". (4) The purchase behavior was based on the scale of Zheng (2020). There are three items in total, such as "I will participate in product purchase under social responsibility activities" (5) Finally, customer experience is based on Lu's (2018) scale, and then according to the needs of this paper to select and change, and finally give six items. The questionnaire used Five-level Likert scale to score the questions of the questionnaire. 1 means very disagreed, 5 means very agree, and finally there are five variables

Sample Description

This study mainly takes the public consumers on the Internet as the survey sample. The questionnaire was published online, and 232 copies were finally received. Except some invalid questionnaires, 207 valid questionnaires were finally recovered, with a recovery rate of 89%. In the valid samples: (1) the gender distribution is as follows: 90 males, accounting for 43.5% of the total, and 117 females, accounting for 56.5% of the total. (2) Age distribution: most of them are 18-28 years old, accounting for 52% of the total number, while a small number of them are 29-44 years old and above 45 years old, accounting for 27% and 21% of the total. (3) Distribution of education level: there are 101 students with bachelor's degree, accounting for 48% of the total, while the proportion of junior high school and below, senior high school, junior college, master's degree and above are 12, 24, 37 and 33 respectively, accounting for 6%, 12%, 18% and 16% of the total. (4) Monthly income: there are 31 respondents with monthly income below 1000 Yuan, accounting for 15% of the total; 84 respondents with monthly income of 1000-2000 account for 41%; 52 respondents with monthly income of 2000-3000 account for 25% of the total; 40 respondents with monthly income above 3000 account for 19% of the total. Sample statistics are shown in Table 1.

Table 1: Sample demographic information.

Demographics	Project breakdown	Number of people	percentage
Gender	Man	90	43.5%
	Woman	117	56.5%
Age	≤17	0	0
	18-28	108	52%
	29-44	55	27%

education	≥45	44	21%
	Less than Junior high school	12	6%
	High school	24	12%
	Training school	37	18%
	Undergraduate	101	48%
Monthly income	Master degree or above	33	16%
	≤1000	31	15%
	1000-2000yuan	84	41%
	2000-3000yuan	52	25%
	≥3000yuan	40	19%

Reliability and Validity Analysis of Questionnaire

Before testing the hypothesis, we should analyze the reliability and validity of our questionnaire data.

According to the previous literature and research, internal consistency is often used as the test method, and then Cronbach's α value is used as the test index. In this study, SPSS 22.0 was used as a tool to test the variables and the whole questionnaire. 4.4 empirical analysis based on structural equation model. Table 2 shows the values of Cronbach's α .

Table 2: The Cronbach's α value of variable.

variable	Corporate Social Responsibility	Gratitude	Purchase intention	Customer experience	Purchasing behavior
Cronbach's α	0.893	0.911	0.859	0.932	0.876

It can be seen from the above table that the Cronbach's α values of the five variables are all greater than 0.85, and the Cronbach's α values are greater than 0.7, which can meet the requirements of internal consistency and high data reliability.

The validity test is mainly to test the validity of the questionnaire, which is measured by Amos. 22.0. It can be seen from the table below that the item factor load in the scale is greater than 0.5, which indicates that the items are valid. The combination reliability C.R of each dimension in the scale is higher than 0.7, and the average extraction variance of the five dimensions ave is higher than 0.5, which means that the following five dimensions have good aggregate validity. We can see the relevant indicators by observing Table 3 and Table 4. To sum up, we can judge that the scale has good validity.

Table 3: Related indicators of validity test.

variable	Item	Standard load	C.R	AVE
Corporate Social Responsibility	Q1.1	0.869	0.8940	0.6804
	Q1.2	0.918		
	Q1.3	0.797		
	Q1.4	0.699		
Gratitude	Q2.1	0.867	0.9138	0.7802
	Q2.2	0.965		
	Q2.3	0.811		
Purchase intention	Q3.1	0.720	0.8643	0.6154
	Q3.2	0.746		
	Q3.3	0.847		
	Q3.4	0.818		
Customer experience	Q5.1	0.849	0.8763	0.7025
	Q5.2	0.851		
	Q5.3	0.814		
Purchasing behavior	Q5.1	0.845	0.9324	0.6972
	Q5.2	0.809		
	Q5.3	0.871		
	Q5.4	0.841		
	Q5.5	0.776		
	Q5.6	0.864		

Table 4: Correlation analysis.

	1	2	3	4	5
1 Corporate Social Responsibility	0.8249				
2 Gratitude	0.660	0.8833			
3 Purchase intention	0.604	0.604	0.7845		

4 Purchasing behavior	0.548	0.579	0.688	0.8382	
5 Customer experience	0.458	0.491	0.483	0.545	0.8349

Empirical Analysis Based on Structural Equation Model

After testing the reliability and validity, this study uses AMOS 22.0 software to draw theoretical graphics and import the questionnaire data to test the above hypotheses. We use Cmin / DF, GFI, AGFI, NFI, IFI, CFI, RMSEA and other seven indicators to verify the fitting of the model. The results showed that Cmin / DF was 2.553, which was less than 3, indicating that it was acceptable; RMSEA was 0.087, less than 1, and the model fitness was acceptable. The following table is the model fitting value, the indexes in the table are acceptable if within the range of 0.7-0.9, and above 0.9 is ideal.

Table 5: Model fit index.

index	Model fitting value	evaluate
GFI	0.885	acceptable
AGFI	0.834	acceptable
NFI	0.915	ideal.
IFI	0.946	ideal.
CFI	0.946	ideal.

After the reliability and validity test and the model fitting results are good, it can be used to test the research hypothesis. Using Amos software, the final results show that all hypotheses are confirmed. The path coefficients are shown in the Table 6, and the model of test results is shown in Figure 2.

Table 6: Path analysis.

Research hypothesis	Path coefficient
H1 There is a positive relationship between corporate social responsibility and consumers' purchase behavior.	0.14*
H2 When enterprises practice social responsibility, consumers will feel grateful.	0.71***
H3 Consumers' gratitude positively influences purchase intention.	0.70***
H5 Purchase intention positively affects purchase behavior.	0.74***

Note: ***It means significant at 0.01 level, * represents significant at 0.05 level

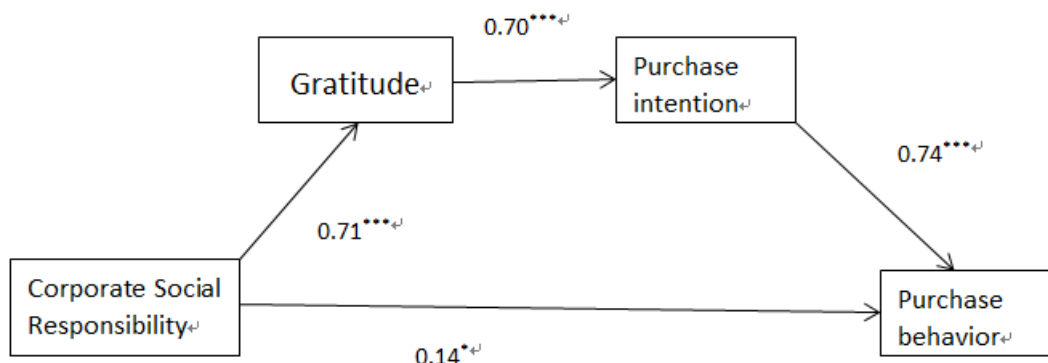

Figure 2: Model test results.

Regulatory Effect Test

In this study, H4 is the customer experience, which plays a moderating role in consumer gratitude and purchase intention. Here, we use SPSS hierarchical regression to test the significance of R2 change. If it reaches the preset significance level, it can prove the moderating effect. The final result shows that the value of SIG f change is greater than 0.05, which proves that customer experience does not play a significant moderating role in consumer gratitude and purchase intention.

Table 7: Model summary.

Model	R	R squared	Adjusted R square	Adjusted R square	Change statistics				
					R square change	F value change	Df1	Df2	Significant f-value change
1	0.640a	0.410	0.404	0.57727	0.410	70.816	2	204	0.000
2	0.641b	0.411	0.402	0.57822	0.001	0.333	1	203	0.565

Table 8: The results of coefficient test.

Model		Coefficient of non-standardization		Standardization coefficient	T	Significance
		B	Standard error	Beta		
1	constant	0.828	0.254		3.262	0.001
	Consumer experience	0.395	0.064	0.372	6.155	0.000
	CSR	0.363	0.058	0.377	6.233	0.000
2	constant	1.139	0.596		1.910	0.058
	Consumer experience	0.316	0.152	0.298	2.084	0.038
	CSR	0.260	0.187	0.271	1.394	0.165
	JHX	0.025	0.044	0.159	0.577	0.565

Note: Customer Experience is the adjustment variable, CSR is the independent variable, JHX is the interaction term between customer experience and CSR

Results Discussion

The final experimental results show that corporate social responsibility has a significant impact on consumers' purchase behavior (0.14*), and it also has a significant impact on consumers' gratitude (0.71**). Gratitude has a positive impact on consumers' purchase intention (0.70**), and consumer purchase intention has a significant impact on consumer purchase behavior (0.74**). Finally, the moderating effect of customer experience on consumers' gratitude and purchase intention was not found to be significant (0.565 > 0.05). It may be that when customers are inspired by gratitude, product experience and platform service are not the most important factors for them, and psychological identification may be the core factor influencing their purchase.

RESEARCH SUMMARY AND PROSPECT

Research Significance

First of all, although there are not a few literatures on social corporate responsibility and consumer behaviors in the literature, few authors put forward the concept of "consumer gratitude", and then discuss the impact of gratitude aroused by corporate social responsibility on consumer behavior. Our research fills up the gap in e-commerce research, and we provide research ideas for this important but lack of representative consumer purchase scenarios.

In addition, in a practical sense, it is a good way for major e-commerce platforms to attract consumers' attention by practicing social responsibility activities. Moreover, the effect does not only stay at the level of attracting consumers, but also has an important impact on consumers' purchase. Therefore, the platform should pay attention to the influence of corporate social responsibility, correctly perform its own social responsibility, pay attention to the social responsibility activities in the society, and be responsible for the whole society in order to bring better development for platform itself.

Insufficient Research

The deficiency lies in the fact that there is no segmentation of customer experience, such as product experience and platform service experience, but simply categorizing these experiences into one category, without discussing to what extent these different experience methods will weaken the effect of corporate social responsibility, which may also be the reason why the final result is not significant. In addition, consumers' purchase behavior has not been further considered under different circumstances. For example, the impact of corporate social responsibility on consumers' purchase behavior is different between products with normal price and products with premium. Finally, the depth of gratitude research on purchase intention is not enough, and the relationship between them should be more specific.

Research Prospects

Future research should be more in-depth analysis of customer experience, mining the different effects of different experiences and considering some preconditions of consumer purchase behavior. On the other hand, we should strengthen the research on consumer psychology and emotion, conduct a deeper research on consumer gratitude, grasp the difference between the impact of consumer gratitude on consumer purchasing behavior and traditional factors, and find out whether the influence of this emotion will be affected by some external factors.

REFERENCE

- [1] Bartlett, M. Y., & DeSteno, D. (2006). Gratitude and prosocial behavior: Helping when it costs you. *Psychological Science*, 17 (4), 319-325.
- [2] Castro-González, S., Bande, B., Fernández-Ferrín, P., & Kimura, T. (2019). Corporate social responsibility and consumer advocacy behaviors: The importance of emotions and moral virtues. *Journal of Cleaner Production*, 231, 846-855.
- [3] Duprey, E. B., McKee, L. G., O'Neal, C. W., Algoe, S. B., & Campos, B. (2020). Stressors, resources, and mental health among Latino adolescents: The role of gratitude. *Journal of Applied Developmental Psychology*, 70, 101191.
- [4] Green, T., & Pelozo, J. (2015). How did the recession change the communication of corporate social responsibility activities? *Long Range Planning*, 48 (2), 108-122.
- [5] Hardjono, T. W., & van Marrewijk, M. (2001). The social dimensions of business excellence. *Corporate Environmental Strategy*, 8 (3), 223-233.
- [6] Hoyer, W. D., Kroschke, M., Schmitt, B., Kraume, K., & Shankar, V. (2020). Transforming the customer experience through new technologies. *Journal of Interactive Marketing*, 51, 57-71.
- [7] Kim, J., & Park, T. (2020). How corporate social responsibility (CSR) saves a company: The role of gratitude in buffering vindictive consumer behavior from product failures. *Journal of Business Research*, 117, 461-472.
- [8] Kwak, S., & Yoo, S. G. (2014). A probe study on global cross-border B2C e-commerce. *The e-Business Studies*, 15 (5), 211-228.
- [9] Liu, J.G. (2015). The influence of consumer behavior characteristics on e-marketing in e-commerce environment. *Management Observation*, (17), 176-177. doi: 10.3969/j.issn.1674-2877.2015.17.071. (In Chinese)
- [10] Novak, T. P., Hoffman, D. L., & Yung, Y. F. (2000). Measuring the customer experience in online environments: A structural modeling approach. *Marketing Science*, 19 (1), 22-42.
- [11] Park, E., Kim, K. J., & Kwon, S. J. (2017). Corporate social responsibility as a determinant of consumer loyalty: An examination of ethical standard, satisfaction, and trust. *Journal of Business Research*, 76, 8-13.
- [12] Romani, S., Grappi, S., & Bagozzi, R. P. (2013). Explaining consumer reactions to corporate social responsibility: The role of gratitude and altruistic values. *Journal of Business Ethics*, 114 (2), 193-206.
- [13] Sen, S., Du, S., & Bhattacharya, C. B. (2016). Corporate social responsibility: A consumer psychology perspective. *Current Opinion in Psychology*, 10, 70-75.
- [14] Williams, L., Bannister, C., Arribas-Ayllon, M., Preece, A., & Spasić, I. (2015). The role of idioms in sentiment analysis. *Expert Systems with Applications*, 42 (21), 7375-7385.
- [15] Xie, C., Bagozzi, R. P., & Grønhaug, K. (February 2019). The impact of corporate social responsibility on consumer brand advocacy: The role of moral emotions, attitudes, and individual differences. *Journal of Business Research*, 95, 514-530.

Impacts of Competitive Uncertainty on Supply Chain Competence and Big Data Analytics Utilization: An Information Processing View

(Full Paper)

Wei-Hsiu Weng*, National Chengchi University, Taiwan, wengvictor@gmail.com

ABSTRACT

Research advancements in big data analytics have invoked tremendous attention from both academics and industries. Many researchers refer that the adoption and application of big data analytics could lead to performance impact to organizations, and therefore further affect organizational adoption intention of this technology. However, few studies discuss the association between business strategy and big data analytics adoption under uncertainty such as pandemics or disasters. Furthermore, the role of firms' functional activities such as supply chain operations has seldom been addressed in the adoption considerations of big data analytics under abnormal situations. In this research, empirical data from enterprises were collected and analyzed to assess the impact of competitive strategy uncertainty on big data analytics adoption and the possible effect of supply chain competence in the linkage. The results supported positive effects of strategy practices and supply chain competence on big data analytics utilization. The implications for management decisions are then elaborated.

Keywords: Big data analytics, information processing view, uncertainty, supply chain competence, competitive strategy.

*Corresponding author

INTRODUCTION

Big data is characterized by scholars and practitioners with three Vs: Volume, or the large amount of data that either consume huge storage or entail of large number of data records; Velocity, which is the frequency or the speed of data generation, data delivery and data change; and Variety, to highlight the property that data are generated from a large variety of sources and formats, and contain multidimensional data fields including structured and unstructured data (Fosso Wamba *et al.*, 2015; Hashem *et al.*, 2015; McAfee & Brynjolfsson, 2012). Big data analytics refers to the methods, algorithms, middleware and systems to discover, retrieve, store, analyze and present big data, in order to generate the fourth V: Value for business.

The development of big data analytics is a response to the world of fast accumulating data, such as social media data, electronic commerce data, geographical data, multimedia streaming data, and many others generated from personal and organizational applications (Weng & Lin, 2013, 2014c). Other emerging technologies, such as cloud computing and internet of things, also enhanced the needs of big data analytics (Weng & Lin, 2014a, 2014d, 2015b). For example, with the rapid pace of development in cloud computing, data centers of both public clouds and private clouds are continuing to accumulate enormous volumes of data; as a result, big data analytics and its applications are becoming ever more noticed (Agrawal, Das, & Abbadi, 2011; Hashem *et al.*, 2015).

While the influences of big data analytics on enterprise performance were explored in previous studies (Fosso Wamba *et al.*, 2015), the essential issue of whether firms will adopt big data analytics remains unresolved, and factors associated with enterprise adoption intention of big data analytics have not been comprehensively investigated. Studies of organizational information processing theory (Galbraith, 1974; Tushman & Nadler, 1978) have shown that the uncertainty that firms encounter when formulating and executing business strategy is an important factor for firms' adoption of innovative information technologies (Koo, Koh, & Nam, 2004; Porter & Millar, 1985; Smith, McKeen, & Singh, 2007). This result leads to the speculation that business strategy pursuit is associated with big data analytics adoption intention. However, so far studies of possible relationships between big data analytics adoption and firms' business level strategies are rare in the literature.

Furthermore, when facing uncertain situations such as a global pandemic or a financial turmoil, supply chain competence is particularly noticeable as a possible factor for big data analytics adoption for several reasons (Hazen *et al.*, 2014; Waller & Fawcett, 2013). First, the growing data volume in supply chain operations. This is because supply chain activities need to be collaborated with all other trading partners across corporate boundary, and supply chains need to be integrated with value chains of all participating parties (Cheung, Myers, & Mentzer, 2010; Cook, Heiser, & Sengupta, 2011). Second, the increasing data velocity in supply chain operations. Many organizations are gradually aware of that they must compete, as part of a supply chain against other supply chains, to quickly reflect customers' changing demands (Wu & Chuang, 2010). And third, the expanding data variety in supply chain operations. Supply chain management is closely integrated with more and more other functions such as production, marketing and information systems (Dong, Xu, & Zhu, 2009; Kozlenkova *et al.*, 2015). For these reasons, this research intends to investigate the linkage between business strategy and big data analytics adoption, and the effect of supply chain competence in this linkage.

The paper begins with a review of the relevant literature about the relationships between business strategy, supply chain competence and big data analytics. Then it proposes a model which links these variables. Following that, the model is tested

using a sample of large Taiwanese companies with global operations. Finally, the findings are presented along with the managerial implications of the study and recommendations for future work.

LITERATURE REVIEW AND HYPOTHESES DEVELOPMENT

Big Data Analytics and Information Processing View

Big data analytics is used to store, convert, transmit and analyze large quantities of dynamic, diversified data, which may be structured or unstructured data, for the purpose of business benefit (Borkar, Carey, & Li, 2012; Chen, Chiang, & Storey, 2012). Big Data processing requires tools and techniques that leverage the combination of various IT resources: processing power, memory, storage, network, and end user devices to access the processed outcomes. Efficient analytical tools are developed to process the large amounts of unstructured heterogeneous data collected continuously in various formats such as text, picture, audio, video, log file and others (Babiceanu & Seker, 2016). Current examples of such tools include the Hadoop Distributed File System (HDFS) (Shafer, Rixner, & Cox, 2010), the parallel processing system MapReduce (Glushkova, Jovanovic, & Abelló, 2017), the non-relational database system NoSQL (Stonebraker, 2010), and others. These tools provide processing functionality for big data which are beyond the application scope of traditional data mining and business analytics tools (Gupta & George, 2016).

Studies of organizational information processing theory (Galbraith, 1974; Tushman & Nadler, 1978) have revealed that the uncertainty that firms confront when pursuing and developing business strategy is an important factor for firms' adoption of innovative information technologies (Koo *et al.*, 2004; Porter & Millar, 1985; Smith *et al.*, 2007). Information processing theory views firms as information processing systems which help firms deal with uncertainty in business decisions and actions. Nowadays, organizations are facing even greater challenge in decision making than before, as the information to be processed is growing rapidly in volume, velocity and variety. This challenge motivated the study and utilization of big data analytics (Bharati & Chaudhury, 2018; Shirish *et al.*, 2018; Wang *et al.*, 2018).

Competitive Uncertainty and Supply Chain Competence

Porter's framework for business strategy of competition is one of the most widely accepted typology of business competition models (A. Miller & Dess, 1993; Porter, 1980). Porter's research in industrial economics suggested two fundamental types of generic business level strategies for achieving above average rates of return: cost leadership and differentiation (Porter, 1980, 1985). Porter proposed that to succeed in business, a firm must pursue one or more of these generic business strategies, and that a firm's strategic choice eventually determines its competitiveness and profitability (D. Miller, 1988). Other scholars argued that the two types of business strategies are not strictly mutual exclusive. Firms adopting cost leadership strategy may seek to deliver distinctive products or services under the main theme of low cost thinking. Firms with differentiation strategy could also attempt low cost operations as long as the uniqueness of products or services is maintained (Hill, 1988; Murray, 1988). Competitive uncertainty triggers firms to adopt contingent and hybrid strategies (Wernerfelt & Karnani, 1987). Competitive uncertainty may be caused by several different types of sources: demand structure, supply structure, competitors and externalities (Wernerfelt & Karnani, 1987). Thus both the supply chain situations of a firm and the external events such as a global pandemic may affect a firm's strategic posture and sustained competitive advantage (Dreyer & Grønhaug, 2004; K.-J. Wu, Tseng, Chiu, & Lim, 2017).

The successful implementation of the business strategies relies on making right decisions on core functions of a firm, such as human resource management, production, marketing, research and development, sales, information systems, and supply chain management. These functions form a value chain and all have a role in lowering the cost structure and increasing the value of products through differentiation (Porter, 1985). A firm's ability to acquire superior functional efficiency, including supply chain competence, will determine if its product offering is differentiated from that of its competitors, and if it has a low cost structure simultaneously. Firms that increase the utility consumers get from their offerings through differentiation, while at the same time lowering their cost structure, can create more value than their rivals, and will acquire a competitive advantage, superior profitability, and profit growth (Hill, 1988; Huo *et al.*, 2014).

Cost leadership strategy is pursued through low cost operations in each segment of supply chain activities, including production scheduling, demand management, sourcing and procurement, inventory management, distribution and delivery (Huan, Sheoran, & Wang, 2004; Lockamy & McCormack, 2004). For differentiation strategy, the principal thinking in these operations are geared towards the design and delivery of distinctive products and services. Differentiation may also eventuate in unique methods or channels of sourcing or delivery, in innovative manufacturing processes or inventory operations in a supply chain (Wagner, Grosse-Ruyken, & Erhun, 2012). Thus, the following two hypotheses are proposed:

- H1. Cost efficiency under competitive uncertainty is positively associated with supply chain competence.
- H2. Differentiation proficiency under competitive uncertainty is positively associated with supply chain competence.

Competitive Uncertainty and Big Data Analytics Utilization

From the information processing view (Galbraith, 1974), an organization is an imperfect decision-making system due to incomplete knowledge. Therefore, firms seek to systematically progress to support decision-making when facing increased uncertainty. Uncertainty is associated with inadequate information related to decision-making. The competitive information

extracted from big data comprises information of sales and marketing, research and development, manufacturing and production, finance and accounting, human resources, and similar data from the other competitors (Tushman & Nadler, 1978). This information can be acquired and processed by applying big data analytics. Organizing and leveraging these big data analytics from functional operations up the hierarchy and systematically using it to ascertain the competitive situation along with the formation of business strategies involve the essence of the managerial decisions on competition (Mathews, 2016). Furthermore, business strategies of most organizations are frequently a combination of their intended strategies and the emergent strategies (Mintzberg, 1985). Firm leaders need to analyze the process of emergence and to make strategy adjustment when appropriate (Mintzberg & Waters, 1985). For this purpose, big data analytics could also serve as the tool to facilitate the strategic decisions to be accurately aligned with competition changes (Aker *et al.*, 2016; Janssen, van der Voort, & Wahyudi, 2017).

Big data analytics with the 3Vs (Volume + Velocity + Variety) provides a clear picture of product use, showing instantly which features customers prefer or dislike, by means of the increased volume, velocity and variety of data collected from customer responses. An example is the effects of word of mouth created by a large number of online visitors on consumer's purchase preference for manufacturers and retailers (Wien & Olsen, 2017; Xie *et al.*, 2016). By analyzing and comparing more dimensions of usage patterns, firms can do much precise customer segmentation, by industry, geography, age, income, and even more granular attributes. Decision makers can apply this deeper knowledge to tailor special offers or after-sale service packages, create features for certain segments, and develop more sophisticated pricing strategies that better match price and value at the segment or even the individual customer level (Qi *et al.*, 2016). These price and value analytics further forms the basis for decisions of differentiation and cost structure.

For companies pursuing cost leadership strategy, cost analytics of all levels is more accurately analyzed to maintain a viable leading cost structure. For firms pursuing differentiation strategy, customer preference analytics determines the need to differentiate their products against the need to keep their cost structure under control in order to offer a product at a competitive price (Xie *et al.*, 2016). In summary, we propose the following hypotheses:

H3. Cost efficiency under competitive uncertainty is positively associated with big data analytics utilization intensity.

H4. Differentiation proficiency under competitive uncertainty is positively associated with big data analytics utilization intensity.

Supply Chain Competence and Big Data Analytics Utilization

Supply chain operations generate and utilize large-scale heterogeneous data with time-varying nature (Gunasekaran, Patel, & Tirtiroglu, 2001). The timely and accurate flow of information is a necessity for successful supply chain operations (White, Daniel, & Mohdzain, 2005). The evolution of big data analytics is expected to transform enterprises' managerial paradigm, including supply chain management (Waller & Fawcett, 2013). The relationships between supply chain competence and information technology adoption have been widely studied. The findings suggest that IT advancement and IT alignment can facilitate the development of supply chain competence (DeGroot & Marx, 2013; Qrunfleh & Tarafdar, 2014; Vijayasarathy, 2010; Wu *et al.*, 2006). These results lead to the conjecture of the association between supply chain competence and big data analytics (Schoenherr & Speier-Pero, 2015; Waller & Fawcett, 2013). The possible association between supply chain competence and big data analytics adoption has thus become a crucial topic to both academics and practitioners (Hazen *et al.*, 2014).

The efficiency considerations in supply chain operations mainly centers around time efficiency, cost efficiency and flexibility (Beamon, 1999; Gunasekaran, Patel, & McGaughey, 2004). The time efficiency in supply chain includes reducing lead time, response time and delivery time of products and services. The cost efficiency consideration in supply chain comprises lowering the costs of materials, inventory, distribution and transportation, and information exchange among various sites in supply chain. The flexibility of supply chain is enhanced by instant adjustment to changes from customer requirements, supplier and distributor conditions, and any other possible events such as natural disasters (Beamon, 1999; Gunasekaran *et al.*, 2004).

The 3Vs capability of big data is desired for efficient supply chain operations. The efficiency in supply chain operations is supported by prompt interchange of status data among parties participating in the supply chain. As the supply chain competence keep enhancing, data volume may grow from more detailed information regarding price, quantity, items sold, time of day, date, customer data, and inventory at more locations and a more dispersed level. Data velocity is also increased because of the frequent updates of sales orders, inventory status and transportation time. Data variety is amplified since the attributes of products, channels of procurement and methods of delivering products and services become more versatile (Robak, Franczyk, & Robak, 2013). These 3Vs of big data are also amplified by joining applications of other emerging technologies such as cloud computing, RFID, and Internet of Things in the supply chain (Angeles, 2005; Atzori, Iera, & Morabito, 2010; Cegielski *et al.*, 2012). Thus, to pursue supply chain competence, firms will intend to adopt big data analytics. Therefore, the hypothesis of this research suggests that:

H5. Supply chain competence is positively associated with big data analytics utilization intensity.

METHOD

Research Framework

Based on our proposed hypotheses, the research framework is illustrated in Figure 1. The main constructs for competitive strategy contingency are cost efficiency and differentiation proficiency. Supply chain competence is the construct for functional operations under uncertainty. Big data utilization intensity is the construct for complex information processing to cope with uncertainty. In addition to the main constructs, control variables of firm size, IT department size, and industry sector are included as these variables may affect firms' intention to adopt information technologies.

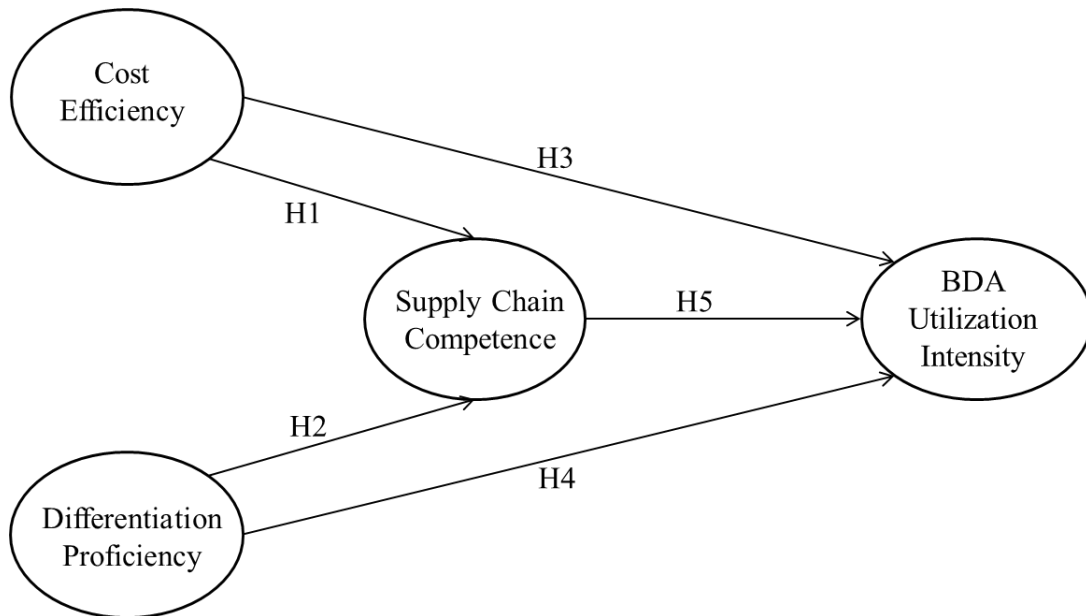

Source:

This

study.

Figure 1: Research framework.

Survey Instrument

The survey instrument was developed using questions derived from the literature on Porter's competitive strategies, the supply chain competence framework, and big data analytics utilization intensity discussed previously. We operationalized the study variables by using multi-item reflective measures on a 7-point scale (1 – strongly disagree; 7 – strongly agree) (Jarvis, MacKenzie, & Podsakoff, 2003). Table 1 presents the construct and item description.

Table 1: Constructs and items used in the survey.

CEF: Cost efficiency under competitive uncertainty
The construct of cost efficiency under competitive uncertainty (CEF) was measured using four items that reflect the extent to which a firm practices cost efficiency. Cost efficiency refers to the generation of higher margins than those of competitors by achieving lower operation costs. CEF1: Operational efficiency CEF2: Economy of scale CEF3: Learning curve of productivity CEF4: Agility and leanness
DFP: Differentiation proficiency under competitive uncertainty
The differentiation proficiency under competitive uncertainty construct (DFP) was measured using four items that reflect the extent to which a firm conduct differentiation. Differentiation entails being unique or distinct from competitors, for example, by providing superior quality, information, prices, distribution channels, and prestige to the customer. DFP1: Quality DFP2: Innovation DFP3: Customization DFP4: Marketing intelligence
SCC: Supply chain competence

The construct of supply chain competence (SCC) was measured using six items. Respondents rated their strength of supply chain operations. The rating included the measurement of resources, output, and flexibility as the strategic goals of supply chain operations.

SCC1: Lead time

SCC2: Response time

SCC3: Inventory control

SCC4: Flexibility

SCC5: Supply side relationship

SCC6: Demand side relationship

BDA: Big data analytics utilization intensity

The big data analytics utilization intensity construct (BDA) served as the dependent variable and was measured using three items by the subjects' responses to whether, if given the opportunity, they would adopt big data analytics for their respective firm to cope with uncertainty.

BDA1: Big data analytics utilization for data volume

BDA2: Big data analytics utilization for data velocity

BDA3: Big data analytics utilization for data variety

Control Variables

Firm size, IT department size, and industry sector are employed as control variables, as these factors have been noted in several studies to affect the intention to adopt information technologies.

Source: This study.

Sample and Data Collection

Empirical data for testing the hypothesized relationships were obtained by conducting a survey of large Taiwanese companies. A questionnaire developed in accordance with Table 1 was implemented as the survey instrument. It was pretested in an iterative manner among a sample of 15 executives and managers. The questionnaire items were revised on the basis of the results of the expert interviews and refined through pretesting to establish content validity. The pretesting focused on instrument clarity, question wording, and validity. During the pretesting, members of the testing sample were invited to comment on the questions and wording of the questionnaire. The comments of these respondents then provided a basis for revisions to the construct measures.

A marketing research organization publishes comprehensive data of the 1,000 largest corporations in Taiwan. Most of these companies are public listed corporations with global transactions. After the pretesting and revision, survey invitations and the questionnaires were mailed to these 1,000 companies. Follow-up letters were sent approximately 15 days after the initial mailing. Data were collected through responses from executives and managers of the companies. Data collection was completed in two months. In total, 201 valid questionnaires were obtained, with a valid response rate of 20.1%. We compared respondent and non-respondent firms in terms of industry, size (number of employees) and revenue. These comparisons did not show any significant differences, suggesting no response bias.

RESULTS

Reliability and Validity

To test the hypothesized research model, partial least square - path modeling (PLS-PM) was applied (Ringle, Wende, & Will, 2005). Table 2 reports the quality indicators of the PLS-PM model.

Table 2: Constructs reliability and validity.

	AVE	CR	CA	VIF	R ²	Latent variable correlations			
						BDA	CEF	DFP	SCC
BDA	0.734	0.892	0.819		0.347	(0.857)			
CEF	0.714	0.909	0.867	1.697		0.504	(0.845)		
DFP	0.727	0.914	0.875	2.022		0.507	0.606	(0.853)	
SCC	0.683	0.928	0.907	1.838	0.456	0.502	0.551	0.644	(0.826)

AVE = average variance extracted, CR = composite reliability, CA = Cronbach's alpha, VIF = variance inflation factor, (···) = square root of AVE

Source: This study.

Composite reliability scores for all indicators are greater than 0.70 and AVE for all scales exceed 0.50. Thus, the test of convergent validity is acceptable (Nunnally & Bernstein, 1994). The Cronbach's alpha was the assessment of the reliability which was scored as > 0.7. This value indicates that there is a positive internal consistency among latent variables and manifest

variables. The VIF values of exogenous latent variables are all less than 5.0, indicating low collinearity among the variables. Successively R² has been estimated to verify the quantity of variance of endogenous variables in relation to exogenous variables. The value of R² results as moderate for all endogenous variables.

Tests of Hypotheses

Test results are shown in Figure 2. All of the hypotheses in the research model are tested significant, providing sufficient support to the hypotheses.

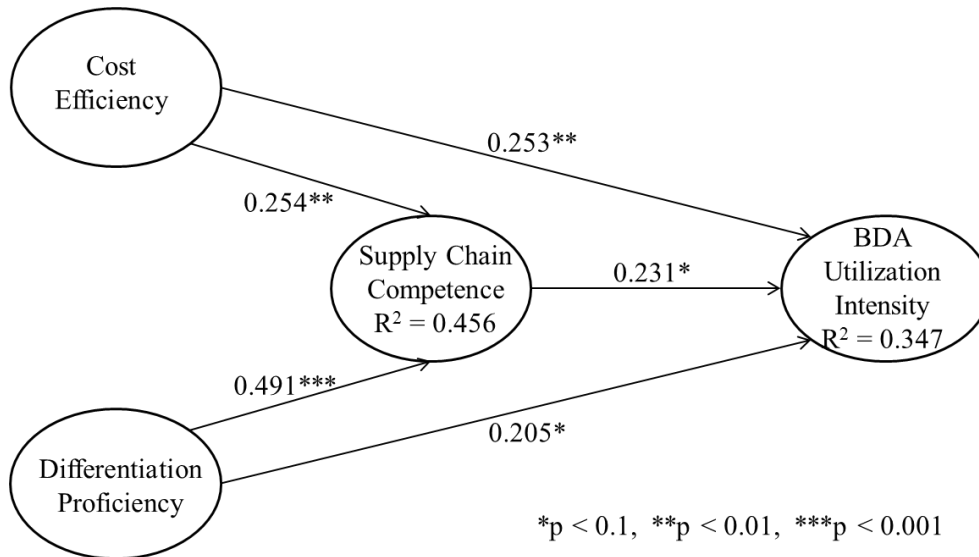

Source: This study.

Figure 2: Results of research model.

Table 3 shows the significance test results of the partial effects in the PLS model using bootstrapping. The VAF (variance accounted for) value for the indirect effect DFP → SCC → BDA is between 0.2 and 0.8, which indicate the partial mediation effect of SCC in the link (Hair *et al.*, 2016; Preacher & Hayes, 2008).

Table 3: Significance tests of effects.

Path	Effect type	Effect	t value	p value	* level	VAF
CEF → BDA	Total effect	0.312	4.396	0.000	***	
DFP → BDA	Total effect	0.318	4.206	0.000	***	
CEF → BDA	Effect without SCC	0.319	4.692	0.001	**	
DFP → BDA	Effect without SCC	0.325	4.348	0.000	***	
CEF → SCC → BDA	Indirect effect	0.059	1.800	0.073	*	0.188
DFP → SCC → BDA	Indirect effect	0.113	2.267	0.024	*	0.356

VAF = variance accounted for
*p < 0.1, **p < 0.01, ***p < 0.001

Source: This study.

The effects of paths in the research model are summarized in Table 4.

Table 4: Significance tests of effects.

Hypothesis	path	Effect from test results
H1	CEF → SCC	Direct effect supported
H2	DFP → SCC	Direct effect supported
H3	CEF → BDA	Direct effect supported Partial mediation of SCC not supported
H4	DFP → BDA	Direct effect supported

		Partial mediation of SCC supported
H5	SCC → BDA	Direct effect supported

DISCUSSION AND CONCLUSIONS

This study investigated the impact of a firm's competitive strategy practices on big data analytics adoption, and tested the possible mediating role of supply chain competence. The results validated our hypotheses that both cost efficiency and differentiation proficiency are positively associated with supply chain competence. Competitive strategy practices concern the competitive positioning, market segmentation and industry environment of a company (Porter, 1980). To survive, grow and sustain, a firm needs to constantly monitor its internal and external status for possible changes. Thus the formulation and execution of a business strategy rely heavily on the collection, extraction, analyze, interpretation and prediction on internal and external status data of a company, in order to make accurate managerial decisions (Claver-Cortés, Pertusa-Ortega, & Molina-Azorín, 2012; McAfee & Brynjolfsson, 2012). Since the supply chain unit of a firm is the operation unit which interact with internal and external partners, its role is critical for competitive strategy practices.

The results also indicate that both cost efficiency and differentiation proficiency are positively associated with big data analytics utilization. For enterprises, big data analytics adoption may facilitate and enhance information processing and exchange. Big data analytics can undertake real-time and high-complexity analytics of vast amounts of operational data, to help enterprises perform strategic decision-making within critical timeframe (Bryant, Katz, & Lazowska, 2008). The 3Vs capability of big data analytics is well aligned for responding to the changes of competitive environment (McAfee & Brynjolfsson, 2012; Waller & Fawcett, 2013). Therefore, big data analytics adoption in a firm is expected to produce significant results concerning competitive strategy practices.

The next critical observation is that the direct effect of supply chain competence on big data analytics adoption intention was positive and significant. This suggests that supply chain competence has direct impacts on big data utilization. From the information processing view (Galbraith, 1974; Tushman & Nadler, 1978), this finding indicates that the perceived complexity and uncertainty for supply chain operations are significant for firms (Waller & Fawcett, 2013), and the information requirement involved may impel firms for big data analytics adoption. A managerial implication here is that a supply chain operation unit of a firm is good at understanding the outside environment because of its participation and collaboration with the other organizations in the supply chain. Therefore, a supply chain operation unit in a firm becomes critical for a firm to make its strategic decisions fit with its surroundings, including technology adoption decisions. This is particularly critical for uncertain situations such as a disastrous pandemic. As the data volume, data velocity, and data variety in supply chain operations continue advancing under uncertainty, the intensity of big data analytics utilization may also keep growing. The supply chain competence is therefore a significant predictor for big data analytics utilization.

Moreover, our empirical results indicate that the link between a firm's differentiation practice and its big data analytics use was partially mediated by the supply chain competence of the firm. This result is not observed for cost efficiency practice. In other words, the link between differentiation and big data analytics adoption is not only direct, but also indirect. This finding suggests that the supply chain management department of a firm may play a key role in the use of big data analytics for differentiation practices. This result provides a valuable reference for firms making management decision on adopting innovative information technologies. This also demonstrates that the complexity of a multi-faceted differentiation practice is more complicated for firms to perform than a cost efficiency practice, and thus required stronger supports of supply chain operations with big data analytics capability.

Further research efforts which focus on collecting more empirical evidences for assessing and validating firm data are recommended to extend the present study. Such research is suggested to address how other emerging technologies relate to business strategies and functional operations. For example, emerging technologies such as internet of things (IoT) (Weng & Lin, 2015a) and augmented reality (AR) (Weng & Lin, 2014d) have received inadequate attention from strategic considerations and technology adoption theories (Weng & Lin, 2014b, 2014d, 2015b). In addition, special attention could be focused on data collected in various sub-industries or specific contexts over an extended period of time. The analysis of such data may enable conclusions to be drawn about more generalized relationships among business level strategies, functional level strategies, and innovative technology adoption.

REFERENCES

- [1] Agrawal, D., Das, S., & Abbadi, A. E. (2011). Big data and cloud computing: Current state and future opportunities. Paper presented at the ACM EDBT, Uppsala, Sweden.
- [2] Akter, S., Wamba, S. F., Gunasekaran, A., Dubey, R., & Childe, S. J. (2016). How to improve firm performance using big data analytics capability and business strategy alignment? *International Journal of Production Economics*, 182, 113-131. doi: 10.1016/j.ijpe.2016.08.018
- [3] Angeles, R. (2005). Rfid Technologies: Supply-chain applications and implementation issues. *Information Systems Management*, 22(1), 51-65. doi: 10.1201/1078/44912.22.1.20051201/85739.7

- [4] Atzori, L., Iera, A., & Morabito, G. (2010). The internet of things: A survey. *Computer Networks*, 54(15), 2787-2805. doi: 10.1016/j.comnet.2010.05.010
- [5] Babiceanu, R. F., & Seker, R. (2016). Big Data and virtualization for manufacturing cyber-physical systems: A survey of the current status and future outlook. *Computers in Industry*, 81, 128-137. doi: 10.1016/j.compind.2016.02.004
- [6] Beamon, B. M. (1999). Measuring supply chain performance. *International Journal of Operations & Production Management*, 19(3), 275-292. doi: 10.1108/01443579910249714
- [7] Bharati, P., & Chaudhury, A. (2018). Assimilation of big data innovation: Investigating the roles of IT, social media, and relational capital. *Information Systems Frontiers*, 1-12. doi: 10.1007/s10796-018-9839-6
- [8] Borkar, V., Carey, M., & Li, C. (2012). Inside "big data management": Ogres, onions, or parfaits? Paper presented at the ACM EDBT/ICDT Joint Conference, Berlin, Germany.
- [9] Bryant, R. E., Katz, R. H., & Lazowska, E. D. (2008). Big-data computing: Creating revolutionary breakthroughs in commerce, science, and society. Paper presented at the Computing Research Initiatives for the 21st Century.
- [10] Cegielski, C. G., Allison Jones-Farmer, L., Wu, Y., & Hazen, B. T. (2012). Adoption of cloud computing technologies in supply chains: An organizational information processing theory approach. *The International Journal of Logistics Management*, 23(2), 184-211. doi: 10.1108/09574091211265350
- [11] Chen, H., Chiang, R. H. L., & Storey, V. C. (2012). Business intelligence and analytics: From big data to big impact. *MIS Quarterly*, 36(4), 1165-1188.
- [12] Cheung, M.-S., Myers, M. B., & Mentzer, J. T. (2010). Does relationship learning lead to relationship value? A cross-national supply chain investigation. *Journal of Operations Management*, 28(6), 472-487. doi: 10.1016/j.jom.2010.01.003
- [13] Claver-Cortés, E., Pertusa-Ortega, E. M., & Molina-Azorín, J. F. (2012). Characteristics of organizational structure relating to hybrid competitive strategy: Implications for performance. *Journal of Business Research*, 65(7), 993-1002. doi: 10.1016/j.jbusres.2011.04.012
- [14] Cook, L. S., Heiser, D. R., & Sengupta, K. (2011). The moderating effect of supply chain role on the relationship between supply chain practices and performance. *International Journal of Physical Distribution & Logistics Management*, 41(2), 104-134. doi: 10.1108/09600031111118521
- [15] DeGroot, S. E., & Marx, T. G. (2013). The impact of IT on supply chain agility and firm performance: An empirical investigation. *International Journal of Information Management*, 33(6), 909-916. doi: 10.1016/j.ijinfomgt.2013.09.001
- [16] Dong, S., Xu, S. X., & Zhu, K. X. (2009). Research note—information technology in supply chains: the value of IT-enabled resources under competition. *Information Systems Research*, 20(1), 18-32. doi: 10.1287/isre.1080.0195
- [17] Dreyer, B., & Grønhaug, K. (2004). Uncertainty, flexibility, and sustained competitive advantage. *Journal of Business Research*, 57(5), 484-494.
- [18] Fosso Wamba, S., Akter, S., Edwards, A., Chopin, G., & Gnanzou, D. (2015). How 'big data' can make big impact: Findings from a systematic review and a longitudinal case study. *International Journal of Production Economics*. doi: 10.1016/j.ijpe.2014.12.031
- [19] Galbraith, J. R. (1974). Organization design: an information processing view. *Interfaces*, 4(3), 28-36.
- [20] Glushkova, D., Jovanovic, P., & Abelló, A. (2017). Mapreduce performance model for Hadoop 2.x. *Information Systems*. doi: 10.1016/j.is.2017.11.006
- [21] Gunasekaran, A., Patel, C., & McGaughey, R. E. (2004). A framework for supply chain performance measurement. *International Journal of Production Economics*, 87(3), 333-347. doi: 10.1016/j.ijpe.2003.08.003
- [22] Gunasekaran, A., Patel, C., & Tirtiroglu, E. (2001). Performance measures and metrics in a supply chain environment. *International Journal of Operations & Production Management*, 21(1/2), 71-87. doi: 10.1108/01443570110358468
- [23] Gupta, M., & George, J. F. (2016). Toward the development of a big data analytics capability. *Information & Management*, 53(8), 1049-1064. doi: 10.1016/j.im.2016.07.004
- [24] Hair, Jr., J. F., Hult, G. T. M., Ringle, C., & Sarstedt, M. (2016). *A primer on partial least squares structural equation modeling (PLS-SEM)*: Sage publications.
- [25] Hashem, I. A. T., Yaqoob, I., Anuar, N. B., Mokhtar, S., Gani, A., & Ullah Khan, S. (2015). The rise of "big data" on cloud computing: Review and open research issues. *Information Systems*, 47, 98-115. doi: 10.1016/j.is.2014.07.006
- [26] Hazen, B. T., Boone, C. A., Ezell, J. D., & Jones-Farmer, L. A. (2014). Data quality for data science, predictive analytics, and big data in supply chain management: An introduction to the problem and suggestions for research and applications. *International Journal of Production Economics*, 154, 72-80. doi: 10.1016/j.ijpe.2014.04.018
- [27] Hill, C. V. L. (1988). Differentiation versus low cost or differentiation and low cost: A contingency framework. *Academy of Management Review*, 13(3), 401-412.
- [28] Huan, S. H., Sheoran, S. K., & Wang, G. (2004). A review and analysis of supply chain operations reference (SCOR) model. *Supply Chain Management: An International Journal*, 9(1), 23-29. doi: 10.1108/13598540410517557
- [29] Huo, B., Qi, Y., Wang, Z., & Zhao, X. (2014). The impact of supply chain integration on firm performance. *Supply Chain Management: An International Journal*, 19(4), 369-384. doi: 10.1108/scm-03-2013-0096
- [30] Janssen, M., van der Voort, H., & Wahyudi, A. (2017). Factors influencing big data decision-making quality. *Journal of Business Research*, 70, 338-345. doi: 10.1016/j.jbusres.2016.08.007
- [31] Jarvis, C. B., MacKenzie, S. B., & Podsakoff, P. M. (2003). A critical review of construct indicators and measurement model misspecification in marketing and consumer research. *Journal of Consumer Research*, 30(2), 199-218.
- [32] Koo, C. M., Koh, C. E., & Nam, K. (2004). An examination of Porter's competitive strategies in electronic virtual markets: A comparison of two on-line business models. *International Journal of Electronic Commerce*, 9(1), 163-180.

- [33] Kozlenkova, I. V., Hult, G. T. M., Lund, D. J., Mena, J. A., & Kekec, P. (2015). The role of marketing channels in supply chain management. *Journal of Retailing*, 91(4), 586-609. doi: 10.1016/j.jretai.2015.03.003
- [34] Lockamy, A., & McCormack, K. (2004). Linking SCOR planning practices to supply chain performance. *International Journal of Operations & Production Management*, 24(12), 1192-1218. doi: 10.1108/01443570410569010
- [35] Mathews, J. (2016). An information processing view of competition analysis. *IUP Journal of Business Strategy*, 13(1), 7-25.
- [36] McAfee, A., Brynjolfsson, E., Davenport, T. H., Patil, D. J., & Barton, D. (2012). Big data: the management revolution. *Harvard business review*, 90(10), 60-68.
- [37] Miller, A., & Dess, G. G. (1993). Assessing Porter's (1980) model in terms of generalizability, accuracy, and simplicity. *Journal of Management Studies*, 30(4), 553-585.
- [38] Miller, D. (1988). Relating porter's business strategies to environment and structure: analysis and performance implications. *Academy of Management Journal*, 31(2), 280-308.
- [39] Mintzberg, H. (1985). Strategy formation in an adhocracy. *Administrative Science Quarterly*, 30(2), 160-197.
- [40] Mintzberg, H., & Waters, J. A. (1985). Of strategies, deliberate and emergent. *Strategic Management Journal*, 6(3), 257-272.
- [41] Murray, A. I. (1988). A contingency view of Porter's "generic strategies". *Academy of Management Review*, 13(3), 390-400.
- [42] Nunnally, J. C., & Bernstein, I. H. (1994). *Psychometric theory* (3 ed.). New York: McGraw-Hill.
- [43] Porter, M. E. (1980). *Competitive strategy*. New York: Free Press.
- [44] Porter, M. E. (1985). *Competitive advantage*. New York: Free Press.
- [45] Porter, M. E., & Millar, V. E. (1985). How information gives you competitive advantage. *Harvard Business Review*, 63(4), 61-78.
- [46] Preacher, K. J., & Hayes, A. F. (2008). Asymptotic and resampling strategies for assessing and comparing indirect effects in multiple mediator models. *Behavior research methods*, 40(3), 879-891.
- [47] Qi, J., Zhang, Z., Jeon, S., & Zhou, Y. (2016). Mining customer requirements from online reviews: A product improvement perspective. *Information & Management*, 53(8), 951-963. doi: 10.1016/j.im.2016.06.002
- [48] Qrunfleh, S., & Tarafdar, M. (2014). Supply chain information systems strategy: Impacts on supply chain performance and firm performance. *International Journal of Production Economics*, 147, 340-350. doi: 10.1016/j.ijpe.2012.09.018
- [49] Ringle, C. M., Wende, S., & Will, A. (2005). *SmartPLS 2.0. M3*. Hamburg: SmartPLS.
- [50] Robak, S., Franczyk, B., & Robak, M. (2013). Applying big data and linked data concepts in supply chains management. Paper presented at the Proceedings of the 2013 Federated Conference on Computer Science and Information Systems, Krakow, Poland.
- [51] Schoenherr, T., & Speier-Pero, C. (2015). Data science, predictive analytics, and big data in supply chain management: Current state and future potential. *Journal of Business Logistics*, 36(1), 120-132. doi: 10.1111/jbl.12082
- [52] Shafer, J., Rixner, S., & Cox, A. L. (2010). The hadoop distributed filesystem: Balancing portability and performance. Paper presented at the Performance Analysis of Systems & Software (ISPASS), 2010 IEEE International Symposium on.
- [53] Shirish, J., Rameshwar, D., J., C. S., Thanos, P., David, R., & Anand, P. (2018). Impact of big data and predictive analytics capability on supply chain sustainability. *The International Journal of Logistics Management*, 29(2), 513-538. doi: doi: 10.1108/IJLM-05-2017-0134
- [54] Smith, H. A., McKeen, J. D., & Singh, S. (2007). Developing information technology strategy for business value. *Journal of Information Technology Management*, 18(1), 49-58.
- [55] Stonebraker, M. (2010). SQL databases vs NoSQL databases. *Communications of the ACM*, 53(4), 10-11. doi: 10.1145/1721654.1721659
- [56] Tushman, M. L., & Nadler, D. A. (1978). Information processing as an integrating concept in organizational design. *Academy of Management Review*, 3(3), 613-624.
- [57] Vijayasathy, L. R. (2010). An investigation of moderators of the link between technology use in the supply chain and supply chain performance. *Information & Management*, 47(7-8), 364-371. doi: 10.1016/j.im.2010.08.004
- [58] Wagner, S. M., Grosse-Ruyken, P. T., & Erhun, F. (2012). The link between supply chain fit and financial performance of the firm. *Journal of Operations Management*, 30(4), 340-353. doi: 10.1016/j.jom.2012.01.001
- [59] Waller, M. A., & Fawcett, S. E. (2013). Data science, predictive analytics, and big data: A revolution that will transform supply chain design and management. *Journal of Business Logistics*, 34(2), 77-84.
- [60] Wang, Y., Kung, L., Wang, W. Y. C., & Cegielski, C. G. (2018). An integrated big data analytics-enabled transformation model: Application to health care. *Information & Management*, 55(1), 64-79. doi: <https://doi.org/10.1016/j.im.2017.04.001>
- [61] Weng, W. H., & Lin, W. T. (2013). A Big Data technology foresight study with scenario planning approach. *International Journal of Innovation in Management*, 1(2), 41-52.
- [62] Weng, W. H., & Lin, W. T. (2014a). Development assessment and strategy planning in cloud computing industry. *International Journal of Electronic Commerce Studies*, 5(2), 257-266. doi: 10.7903/ijecs.1158
- [63] Weng, W. H., & Lin, W. T. (2014b). Development assessment and strategy planning in mobile computing industry. Paper presented at the 2014 IEEE International Conference on Management of Innovation and Technology, Singapore.
- [64] Weng, W. H., & Lin, W. T. (2014c). Development trends and strategy planning in big data industry. *Contemporary Management Research*, 10(3), 203-214. doi: 10.7903/cm.12288

- [65] Weng, W. H., & Lin, W. T. (2014d). A scenario analysis of wearable interface technology foresight. Paper presented at The International Conference on Electronic Business (ICEB), Taipei.
- [66] Weng, W. H., & Lin, W. T. (2015a). A mobile computing technology foresight study with scenario planning approach. *International Journal of Electronic Commerce Studies*, 6(2), 223-232. doi: 10.7903/ijecs.1242
- [67] Weng, W. H., & Lin, W. T. (2015b). The impact of internet of things technologies on supply chain performance: The mediating role of competitive strategy. Paper presented at the The International Conference on Electronic Business (ICEB), Hong Kong.
- [68] Wernerfelt, B., & Karnani, A. (1987). Competitive strategy under uncertainty. *Strategic Management Journal*, 8(2), 187-194.
- [69] White, A., Daniel, E. M., & Mohdzain, M. (2005). The role of emergent information technologies and systems in enabling supply chain agility. *International Journal of Information Management*, 25(5), 396-410. doi: 10.1016/j.ijinfomgt.2005.06.009
- [70] Wien, A. H., & Olsen, S. O. (2017). Producing word of mouth – a matter of self-confidence? Investigating a dual effect of consumer self-confidence on WOM. *Australasian Marketing Journal (AMJ)*, 25(1), 38-45. doi: 10.1016/j.ausmj.2017.01.005
- [71] Wu, F., Yenyurt, S., Kim, D., & Cavusgil, S. T. (2006). The impact of information technology on supply chain capabilities and firm performance: A resource-based view. *Industrial Marketing Management*, 35(4), 493-504. doi: 10.1016/j.indmarman.2005.05.003
- [72] Wu, I.-L., & Chuang, C.-H. (2010). Examining the diffusion of electronic supply chain management with external antecedents and firm performance: A multi-stage analysis. *Decision Support Systems*, 50(1), 103-115. doi: 10.1016/j.dss.2010.07.006
- [73] Wu, K.-J., Tseng, M.-L., Chiu, A. S., & Lim, M. K. (2017). Achieving competitive advantage through supply chain agility under uncertainty: A novel multi-criteria decision-making structure. *International Journal of Production Economics*, 190, 96-107.
- [74] Xie, K., Wu, Y., Xiao, J., & Hu, Q. (2016). Value co-creation between firms and customers: The role of big data-based cooperative assets. *Information & Management*, 53(8), 1034-1048. doi: 10.1016/j.im.2016.06.003

Improvement of Market Economy Management Measures for Innovative Enterprises under Block Chain Technology

(Full Paper)

Xiuming Guan, Business School of Macau University of Science and Technology, China,
guanxiuming406@126.com

Rongyu Zhang*, Nanyang Technological University, China, rzhang022@e.ntu.edu.sg

ABSTRACT

In order to solve the financing difficulties of innovative Small and Medium Enterprise (SMEs) in the financial and economic field, this research proposes a market economy management measure for innovative enterprises, namely the enterprise credit information sharing model based on block chain technology. Firstly, the problems existing in the sharing model based on block chain technology are analyzed, and the basic model framework of block chain is adopted to improve the sharing model. Secondly, according to the improved Practical Byzantine Fault Tolerance (PBFT) consensus mechanism, the simulation experiment design of the credit information sharing model of enterprise market economy management measures is carried out. Finally, the improved sharing model proposed in this research is evaluated in terms of fault tolerance and throughput. The results show that the improved market economy management measures based on block chain technology in this research can meet certain fault tolerance rate, and the throughput is relatively stable. To some extent, it can meet the needs of credit information trading and sharing, and solve the difficulties of enterprise information sharing and low efficiency of data exchange.

Keywords: Block chain Technology, Improve Finance for Enterprise, PBFT, Credit Reporting

*Corresponding author

INTRODUCTION

With the continuous development of credit economy, China's innovative SMEs not only have the problem of financing difficulties, but also often don't enjoy the financial services provided by Banks or other financial institutions. Nowadays, the market demand for credit information sharing is very large. As a very important link in China's financial economy, the problem of credit information sharing has not been fully solved (Saber *et al.*, 2019). In addition, the information of innovative SMEs is not transparent, the financial management system is not clear, leading to the enterprise credit information access more difficult. Although China has established a large scale, wide coverage and the most comprehensive credit investigation system (Navadkar *et al.*, 2018), in the innovative Internet field, there are a large number of debt personnel outside of licensed financial institutions whose debt information is not included (Peck, 2017). Therefore, only when the credit information sharing mechanism is perfect, innovative SMEs can conduct credit evaluation on their own enterprises, help enterprises to obtain financing, and realize the steady improvement and development of market economy management (Liu *et al.*, 2011).

In recent years, with the continuous innovation and development of blockchain technology, as a decentralized distributed database, the application scope of blockchain is expanding, involving enterprise supply chain management, government public management and social security, financial market, digital asset transaction, etc. (Zhang *et al.*, 2017). Block chain technology is a kind of chained data structure combining data blocks in chronological order, and ensuring that they are not tampered or forged by means of encryption (Visvizi *et al.*, 2018). Blockchain technology has successfully affected the economic strategic plans of enterprises, but has not completely solved the difficulty of providing credit information for enterprises to share (Puthal *et al.*, 2018). From the perspective of the use of corporate credit data, the secondary use of data is likely to cause corporate privacy leakage or resale. In the era of big data, data privacy protection has become a new challenge (La Monaca *et al.*, 2010). From the perspective of data management, user data may be tampered with or deleted, resulting in the unguaranteed ownership of user data in the enterprise. However, blockchain technology has the advantages of being trustworthy and not tampered with, so the birth of blockchain technology provides solutions and directions for information sharing (Mengelkamp *et al.*, 2018). Most of the existing block chain models are designed for the public chain, because the public chain mechanism requires mining, resulting in a large amount of resource waste and throughput is difficult to meet the needs of credit information trading and sharing. Although the Byzantine algorithm has certain consensus efficiency, due to the limitations of the algorithm itself, it can't be directly applied to the block chain model.

To sum up, this research designs an improved information sharing model based on block chain technology. By combining with the Shared environment, the block chain framework model is improved. It is beneficial to solve the problem of quantity and quality of data information in the management measures of market economy of enterprises, serve for the improvement and enrichment of credit investigation products of enterprises and individuals, and further promote the sustainable development of national economy and the rationalization construction of social credit system.

METHODS

Analysis of sharing model based on block chain technology

Enterprise economic management activities will produce a variety of credit records, the effective information sharing mechanism is currently facing great challenges. Part of the block chain design can't be fully applied to the enterprise credit information sharing model, the main reasons include the following: I: As the underlying technology of bitcoin, blockchain is essentially a decentralized distributed database (Taleb, 2019). Most of the models composed of block chain technology adopt the architecture of public chain, which requires a large number of nodes to ensure its normal operation (Lewis *et al.*, 2017). In addition, the way the public chain architecture maintains the blockchain is proved by the workload, which causes a great waste of resources. A large number of nodes will not participate in the block chain model of credit information sharing. Only some enterprises requiring credit investigation will supervise and maintain the block chain of information investigation. II: The block chain technology is open to the public, and the data on it is open and transparent. All members can query the data and relevant development information on the block chain through the open interface. However, the confidentiality of information should be guaranteed during the sharing of credit data. As the credit investigation data is very large, it can't be transmitted directly through block transactions, but only through the chain (Crosby *et al.*, 2016). Therefore, the current problem for enterprise credit investigation agencies is how to use new technology to manage and maintain the shared data.

Improved design of sharing model based on block chain technology

The credit status of enterprises is usually reflected by the basic information and credit information of enterprises, which usually comes from government departments, commercial Banks, trust companies, and leasing companies. In addition, more and more non-traditional data are also gradually collected and used as credit information, such as public information of government departments, electricity, communication and water charges, and even e-commerce transaction data and social data (Kwok *et al.*, 2019). However, these huge credit data resources are relatively dispersed, and new market economy management measures need to be developed and applied urgently. This paper takes the enterprise credit investigation agency as the demand side of the enterprise confidence sharing platform. When it is necessary to collect personal credit investigation information, the enterprise credit investigation agency needs to ensure the authenticity of the information. As shown in Figure 1, the model designs the roles of the information subject, including the information subject, credit reference agency, credit information provider, cloud service provider, and regulatory agency.

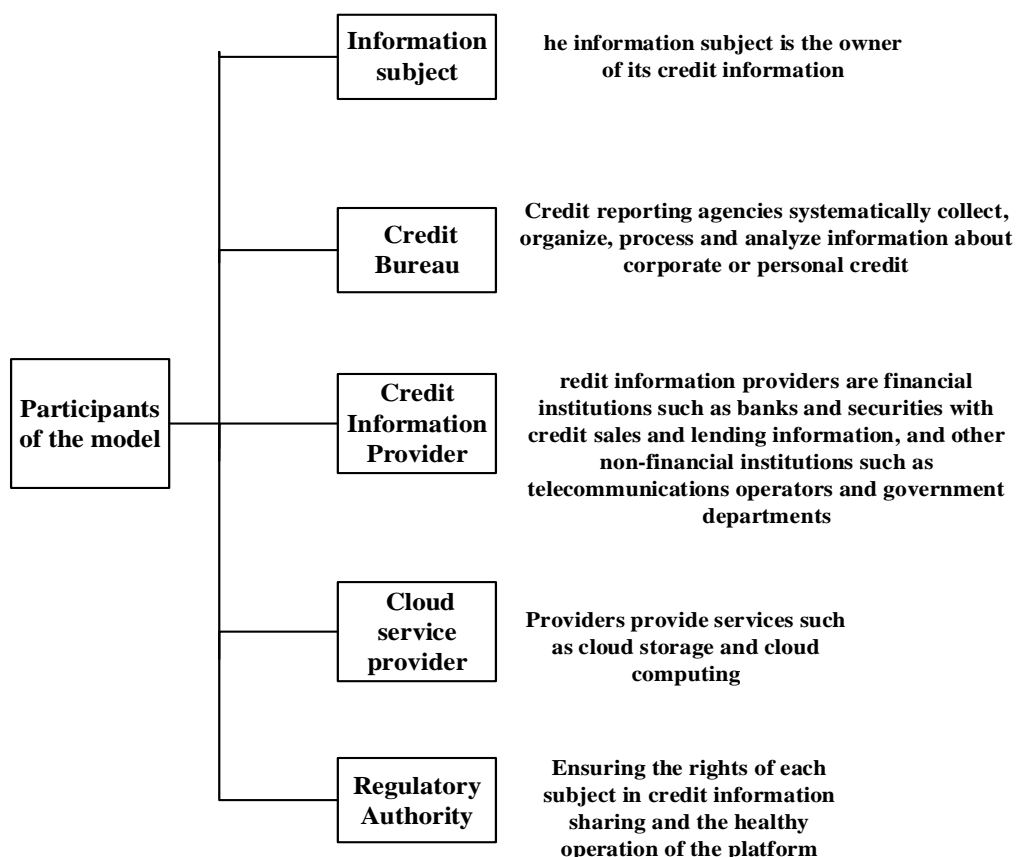

Figure 1: Role classification of information subject in model design

The design of the model framework adopts the basic framework of the block chain model, as shown in Figure 2, including P2P network, message transmission mechanism, block data structure and the new basic framework (Hong, 2020). These new basic frameworks include: the interaction between enterprise credit bureaus and principals, between cloud servers, and between supervisory agencies.

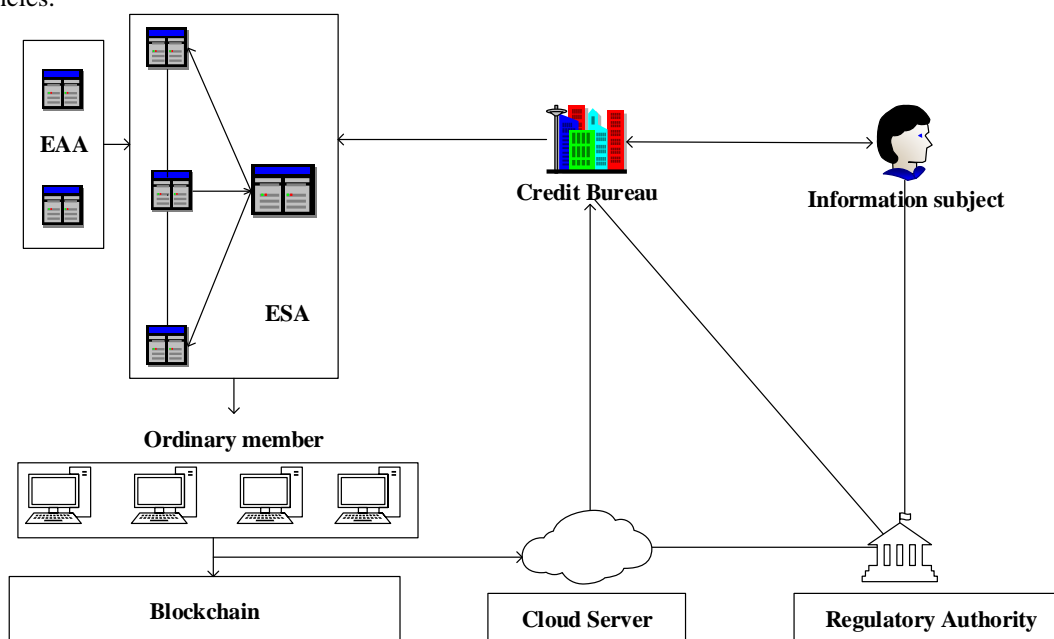

Figure 2: Block chain technology based on the enterprise credit agency information sharing model framework

Among them, the realization of the interaction between the enterprise credit investigation agency and the information subject requires the authorization of the user for the requested data. Then, the enterprise credit investigation agency uses the authorization information signed by the information subject to initiate a request to the credit information provider to obtain the corresponding data (Lemieux, 2016). The interaction between the enterprise credit investigation agency and the cloud server requires the credit information provider to encrypt and upload relevant data to the cloud server according to certain data format requirements after receiving the request. In order to protect the rights and interests of the credit information provider, the credit information provider initiates the transaction containing the summary of uploaded data, the request object, metadata and other information to the block chain node to obtain the upload certificate (Niranjanamurthy *et al.*, 2019). The request records of user authorization and credit information agencies, as well as data uploaded by credit information providers, are recorded on the block chain, providing a fair and credible credit information sharing environment. The interaction between enterprise credit investigation agencies and regulatory agencies is to solve some disputes in the sharing of credit investigation information. The establishment of regulatory agencies in this model protects the rights and interests of each participant.

The design of the consensus mechanism in market economy management measures of enterprises adopts improved PBFT algorithm (Gao *et al.*, 2019). The complexity of the original PBFT algorithm is reduced from exponential to polynomial, which solves the low efficiency of the original Byzantine fault-tolerant algorithm (Yeoh *et al.*, 2017). However, this algorithm is proposed based on C/S architecture, while block chain is proposed based on P2P network architecture. Due to the obvious difference between the two, there are many problems if the original PBFT algorithm is directly applied to the block chain model. Therefore, the original PBFT algorithm and algorithm protocol need to be improved appropriately, and the roles of the client and server of the original PBFT algorithm should be changed accordingly. Based on this, an improved PBFT consensus mechanism is designed. The improvement idea is to limit the transfer nodes and redefine the number of participating consensus nodes in the block chain network, so as to avoid the network channel blockage caused by too many nodes. Furthermore, on the basis of the improved PBFT algorithm, the verification function of the primary node is separated from other functions to reduce the task load of the primary node and improve the performance of the improved model. The main operating process of the improved consensus mechanism is shown in Figure 3.

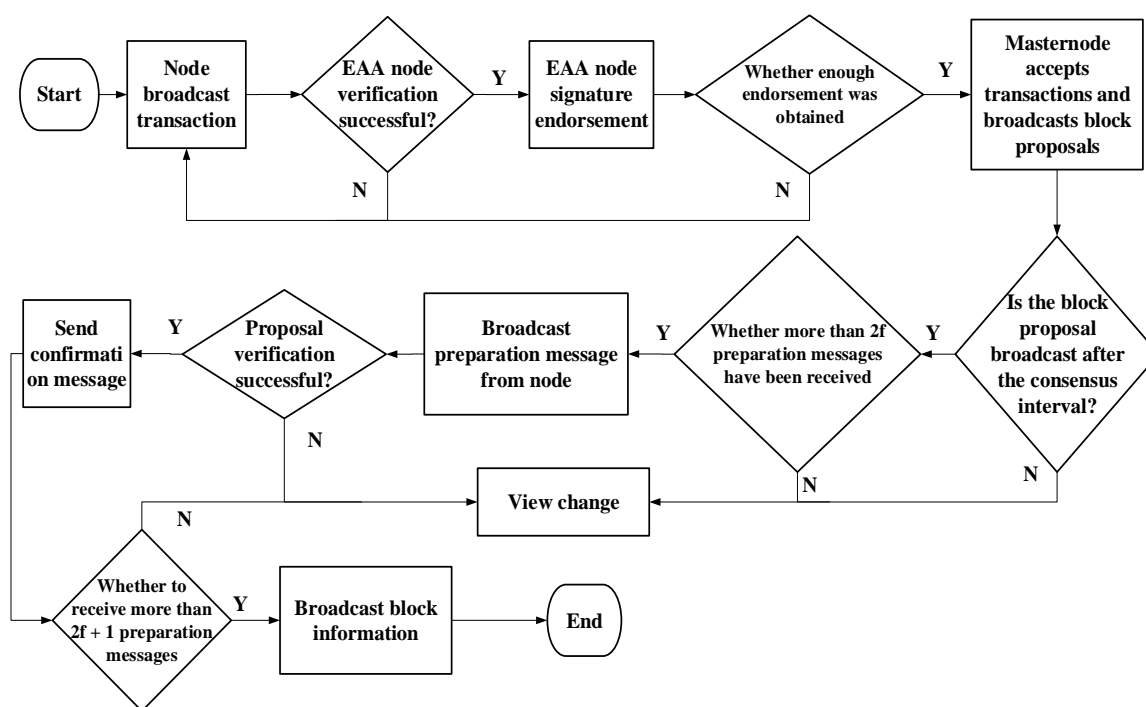

Figure 3: The improved consensus mechanism flowchart

The basic process design of the consensus mechanism in the improved market economy management measures is mainly composed of three parts. The user authorization, publish requests, and upload information are obtained. The agency needs authorization from the information body to issue the relevant task request. In this process, the enterprise needs to release the data source (Company Name), main content (Resource), Purpose (Purpose), Scope (Scope) and Public Key (Public Key) to the information body. The purpose is to explain the information collected and its purpose. After authorization, the information subject returns SIGSI (hash(m)) of its signed authorization information to the enterprise credit investigation agency. Corporate credit bureaus issue sharing requests to the network through clients. These include request type V and request time T, lock time T, get user authorization phase message m, and authorization letter. After verifying the signature of the information subject, the client outputs the signature result Veried-m and publishes the Request.

C→S: m, among them, m= (Company Name, Resource, Purpose, Scope, Public Key)

S→C: SIGSI (hash(m))

Request= (V, T, t, Public Key, input (), output ())

Among them, input= (m, SIGSI (hash(m)), SIGCB (hash(m))), output=(Veried-m)

According to the sharing request, the provider of credit information needs to upload the data to the block chain network in a certain format or upload the encrypted data to the cloud server, so that the data summary, metadata and other credit information can be broadcast to the block chain network through transactions. The specific block chain model workflow is shown in Figure 4. After obtaining user authorization, publishing the SHARED request, and broadcasting the transaction, the EAA (Enterprise Audit Alliance) node is used to verify whether the transaction information is uploaded and whether the data transaction format is correct. If the verification passes, then the EAA node signature endorsement is carried out. Only when the EAA node signature is endorsed by a sufficient number of rows can it be considered as a legitimate transaction, so as to carry out the master node packaging link of ESA (Enterprise Service Alliance) node and enter the three-stage consensus link. After the completion of the task, each node adds the block to the ledger maintained by itself. When the transaction appears on the block chain, it means that the requested task has been uploaded and completed. At this point, the enterprise credit investigation agency can access the Shared data through the key.

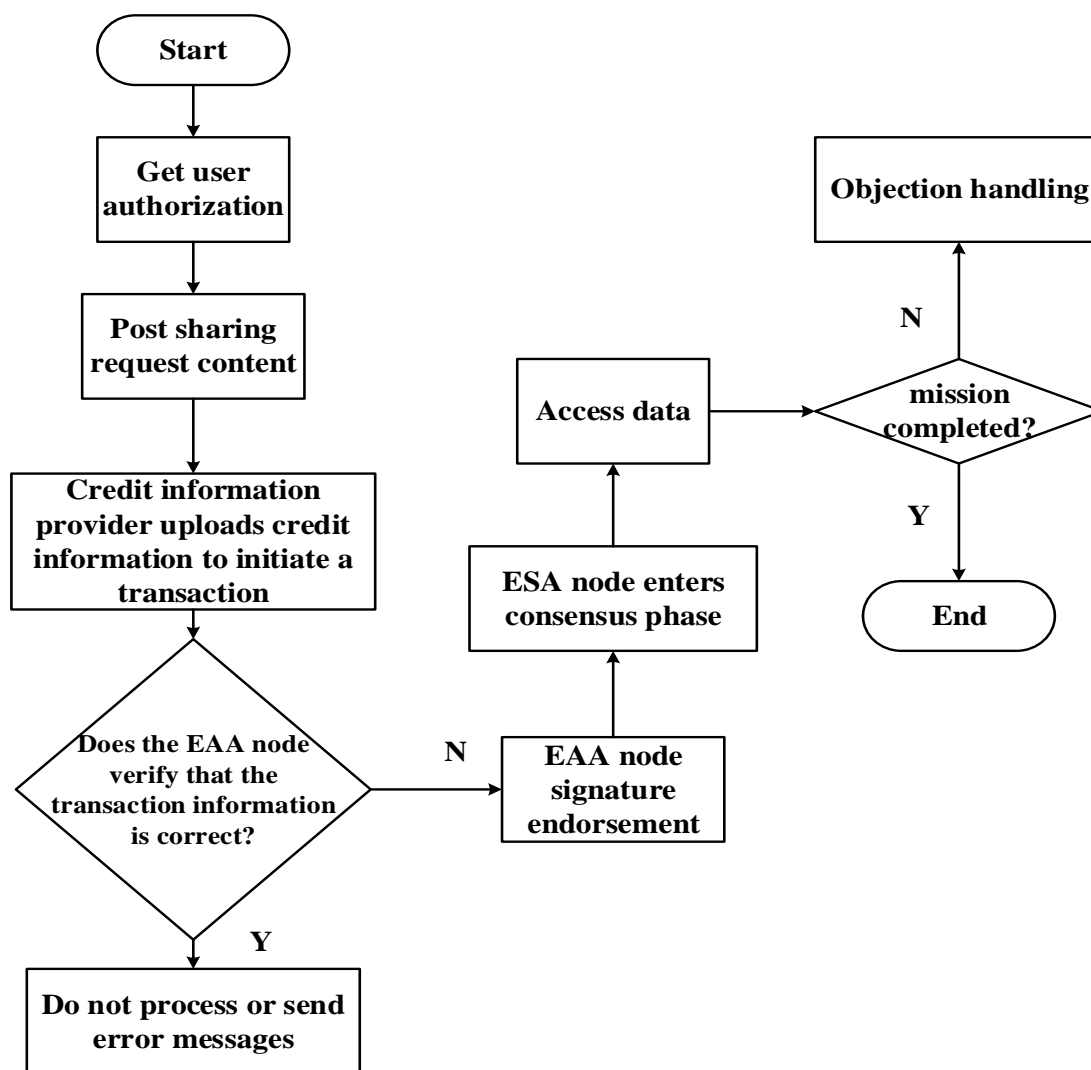

Figure 4: Block chain simulation basic workflow flowchart

In order to achieve the control of access to credit data, but also prevent information providers to upload the same data encryption information with the increase of data demand, the block chain data sharing scheme based on proxy re-encryption is used to share the data of the cloud server. A protocol scheme is provided for proxy re-encryption, in which the primary node acts as the proxy for the re-encryption operation. The specific protocol is divided into the following steps: step 1: the key is generated: $\text{KeyGen}(1k) \rightarrow (pki, ski)$. A pair of public and private keys (pki, ski) of user i is output according to the security parameter $1k$. Step 2: the re-encryption key is generated: $\text{ReKeyGen}(pkA, skA, pkB, skB) \rightarrow rA \rightarrow B$. According to the public key and private key of information provider A and the public key of enterprise credit investigation agency B, the proxy re-encryption key is output. Step 3: based on the public key and credit information, the information provider outputs the ciphertext of the credit information and then transmits it to the cloud server: $\text{Encrypt}(pkA, m) \rightarrow cA$. Step 4: $\text{ReEncrypt}(rkA \rightarrow B, cA) \rightarrow rA \rightarrow B$ credit information provider transmits the re-encryption key $rA \rightarrow B$ of its agent to the block chain by means of transaction. The consensus node verifies the transaction, and the master node performs the re-encryption operation. According to the agent re-encryption key $rA \rightarrow B$ and cA of A, the heavy encrypted ciphertext cB is output for B. Step 5: $\text{Decrypt}(skB, cB) \rightarrow m$ is decoded. Enterprise credit machine uses its private key skB and ciphertext cB to output original plaintext m .

The simulation experiment design of the improved information sharing model

The simulation experiment in this paper is to simulate the credit investigation process of an enterprise in a stand-alone environment, including four processes: enterprise registration, Shared data item design and upload, transaction transmission, and consensus realization. Enterprise registration starts the process through ports from 5000 to 5005, and 5 blockchains are constructed through Flask framework to simulate 5 registered enterprises. Sharing credit investigation enterprises can encrypt relevant information and upload it to the cloud server, and then upload the summary and metadata of the encrypted credit investigation data to the block chain network through transactions. Due to the different purposes of credit investigation, the collected data are not the same. Five enterprises in the simulation experiment upload the data to be shared to the cloud server using aes-128 encryption and initiate the transaction through the block chain network.

Five companies in the simulation upload their own credit data and then initiate five transactions. Firstly, the transaction passes through the EAA node, which verifies the accuracy of the transaction structure and uploaded data. After successful verification, the transaction signature is carried out, and the transaction data is encapsulated and broadcast to the master node in ESA. Figure 5 shows the specific transaction validation process for the EAA node. The master node in ESA collects the transaction after the signature of the previous section and verifies it, and the transaction is legal when the verification passes. Finally, the block is packaged and generated, and the consensus process is conducted through ESA, as shown in Figure 6.

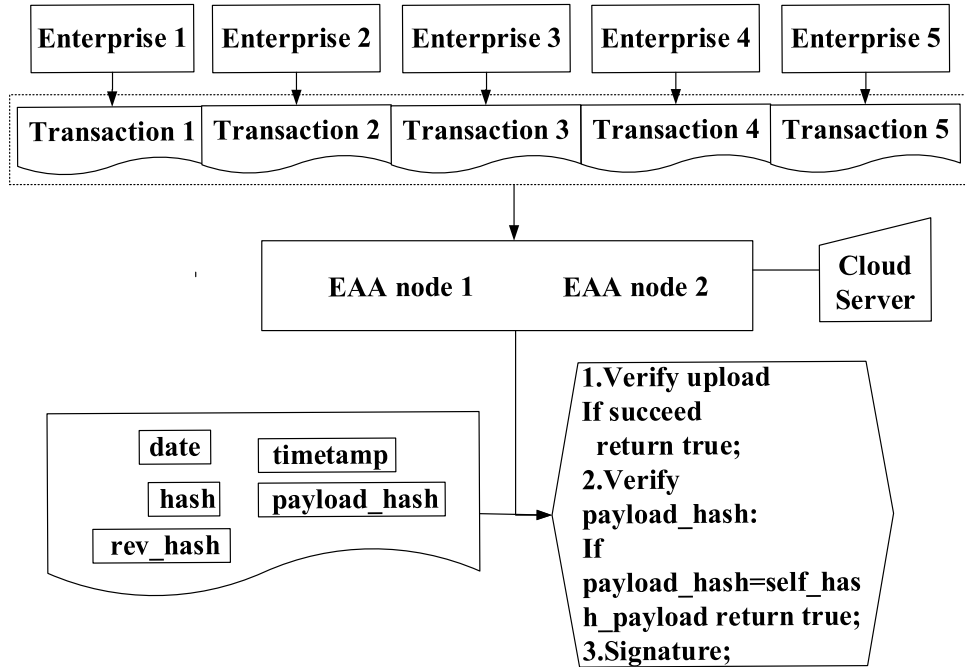

Figure 5: Transaction verification process

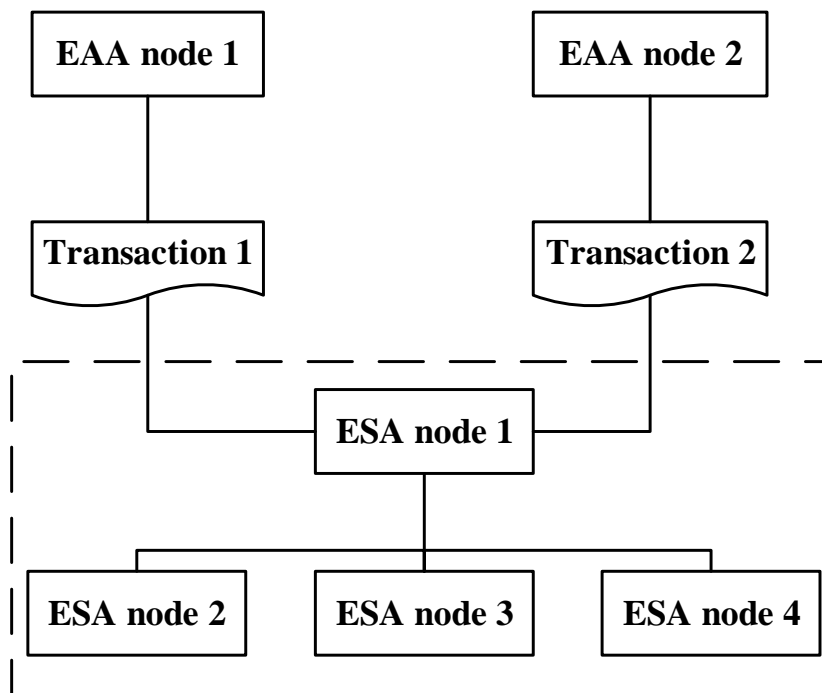

Figure 6: Block generation and consensus process

RESULTS

Analysis of the advantages of the improved sharing model

Based on the market economy management measures designed based on the combination of block chain technology and enterprise credit information sharing scenario, the improved PBFT consensus algorithm is adopted. Through the design of EAA nodes and ESA nodes, the number of consensus nodes and the communication between nodes can be reduced to improve the consensus efficiency. The functional advantages of its model are shown in Table 1.

Table 1: The advantages of credit information sharing model

Advantages	Specific manifestations
Protecting the ownership and rights of user data	Authorizing all actual actions and information before collecting credit information related to the user. In the sharing process, objection records on the block chain are processed by regulators.
Solving the problem of data abuse and low exchange efficiency	The sharing model established through the block chain technology completely records the transaction information. And the transaction data can't be tampered with, and any participant in the sharing can't deny its actions. The transaction information is uploaded to the cloud database through encryption to ensure the authenticity of the Shared data.
Solving the problem of information sharing difficulty and data forming island	By sharing information on a trusted credit information sharing platform, the willingness of credit information providers to share can be promoted.

Performance analysis of experimental results of the improved Shared model

The maximum number of node errors that can be tolerated by the improved PBFT algorithm is:

$$f = \lfloor (n-1) / 3 \rfloor \quad (1)$$

Fault tolerance represents the important performance of the distributed system implementation, that is, when the node fails, it can recover itself without affecting the overall performance of the system. When f is 0, 1, 2, 3, 4, the maximum node fault-tolerant test results are shown in Table 2.

Table 2: Fault tolerance test results

Fault tolerance	Test results	Failure node
0	Success	None
1	Success	Primary node, slave node 1,2,3
2	Success	Master node + slave node 1, slave node 1+ slave node 2
3	Failure	Any node other than the master node, except one slave node
4	Failure	Any node other than the master node, except one slave node

When the improved PBFT algorithm performs view replacement, it indicates that the primary node is invalid, and the new primary node is selected to continue the consensus operation. It can be concluded from the experimental results that when the number of consensus nodes is 4, the number of failed nodes is only one. No matter which node fails, the final agreement can be

reached. When the failure node is 2, the consensus result cannot be reached. Therefore, the improved PBFT algorithm designed in this paper meets certain fault-tolerant performance.

Whether the improved PBFT algorithm can efficiently process transaction requests per unit time is calculated as follows:

$$TPS_{\Delta t} = \frac{Transactions_{\Delta t}}{\Delta t} \quad (2)$$

In Eq. 2, Δt is the time interval between the start of the transaction and the block confirmation. $Transactions_{\Delta t}$ is the total volume of transactions in a block. The JMeter performance testing tool simulates that 60 users simultaneously send simulated corporate credit information to a transaction process in a single machine. When the time interval between the start of the transaction and the end of the confirmation block is 10s, 20s, 30s, 40s, 50s and 60s, each transaction volume is repeated for 25 times, and the measurement results are shown in Figure 7.

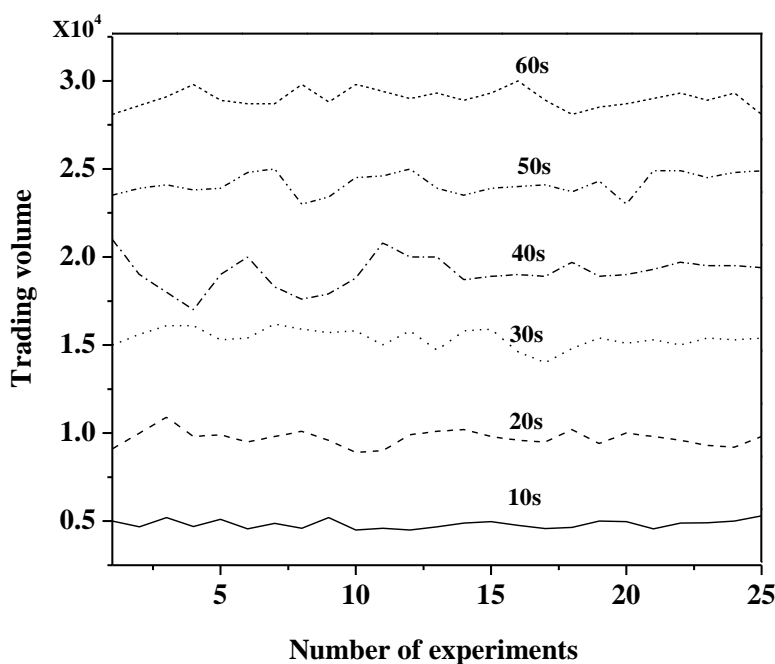

Figure 7: Trading volume test results at different time intervals

It can be concluded from the test results that the improved PBFT algorithm has stable throughput at each time interval and can meet commercial applications to a certain extent.

DISCUSSION

Due to its advantages of decentralization and tamper-proof, blockchain technology has become the focus of more and more researchers, and its potential has been highly valued by the government, especially financial regulators. Some researchers in China have realized the availability of block chain technology in the sharing of enterprise credit information and proposed to apply the block chain technology to the construction of enterprise credit system. Sun *et al.* (2018) proposed a data trading model at the regulatory level based on the block chain technology. Morkunas *et al.* (2019) proposed the application of block chain technology to the data trading market framework of credit investigation industry based on the core data problem of credit investigation innovation in Europe. Suggestions and ideas are provided for the establishment of this model, but its feasibility needs to be further analyzed. In this study, block chain technology is applied to the establishment of enterprise credit sharing model by referring to its data trading ideas, and an improved PBFT consensus algorithm is added on the basis of the optimized sharing model to further integrate block chain technology and information sharing mechanism. Wang *et al.* (2019) upgraded the block chain technology to a "decentralized + centralized" "two-channel" credit investigation technology based on big data, providing effective solutions for Internet economic management, but problems in risk control need to be solved urgently. In this study, the block chain model and information sharing are perfectly integrated through the improved Byzantine algorithm, and data sharing and information management are realized at the same time. Compared with the "double channel" credit investigation technology, it effectively solves the problem of large credit investigation data and complicated Shared data management during the transmission. In addition, the cloud server is used to store the Shared data, and the scheme of privacy protection and Shared access is also designed to solve the risk control problem of the credit investigation platform proposed by other scholars to ensure credit information provider uploads data successfully and credit enterprises successfully receive the corresponding credit information (Kuo *et al.*, 2020).

CONCLUSION

In order to solve the problem that PBFT consensus mechanism of credit information in enterprise market economy management measures is difficult to be directly applied to block chain model, based on the block chain technology, the PBFT consensus algorithm is improved, and the EAA node and ESA node as well as the sharing model to reduce the number of consensus nodes are designed. Through comparative analysis with the original model, it is found that the improved model can guarantee the ownership of user data and has the advantage of high data exchange efficiency. Through the evaluation of the improved model, it is found that when the improved PBFT algorithm changes the view, the failure of single node won't lead to the model error. Moreover, it can be tried to start the switching protocol and reach a consensus again, which indicates that the model can meet a certain fault tolerance rate. It can be concluded from the measurement results of transactions at various time intervals that the transaction curve trend is relatively stable, which proves that the throughput of this model is relatively stable. Therefore, the improved model proposed in this research gives full play to the feasibility of market economy management measures and can meet certain commercial applications.

However, the enterprise credit information sharing model proposed in this research based on the block chain technology is not enough to completely protect the enterprise privacy. Therefore, on the premise of realizing credit information sharing, it is necessary to improve and further study the security and privacy protection of user data.

REFERENCES

- [1] Crosby, M., Nachiappan, Pattanayak, P., Verma, S., & Kalyanaraman, V. (2016). Blockchain technology: Beyond Bitcoin. *Applied Innovation Review*, June(2), 6-19.
- [2] Gao, S., Yu, T., Zhu, J., & Cai, W. (2019). T-PBFT: An EigenTrust-based practical Byzantine fault tolerance consensus algorithm. *China Communications*, 16(12), 111-123.
- [3] Hong, S. (2020). P2P networking based internet of things (IoT) sensor node authentication by Blockchain. *Peer-to-Peer Networking and Applications*, 13(2), 579-589.
- [4] Kuo, T. T., Kim, J., & Gabriel, R. A. (2020). Privacy-preserving model learning on a blockchain network-of-networks. *Journal of the American Medical Informatics Association*, 27(3), 343-354.
- [5] Kwok, A. O., & Koh, S. G. (2019). Is blockchain technology a watershed for tourism development? *Current Issues in Tourism*, 22(20), 2447-2452.
- [6] La Monaca, G., & Schiralli, I. (2010). Data protection, privacy. *La Clinica Terapeutica*, 161(2), 189-191.
- [7] Lemieux, V.L. (2016). Trusting records: is Blockchain technology the answer? *Records Management Journal*, 26(2), 110-139.
- [8] Lewis, R., McPartland, J., & Ranjan, R. (2017). Blockchain and financial market innovation. *Economic Perspectives*, 41(7), 1-17.
- [9] Liu, Y. M., Yin, F. F., & Fu, X. Z. (2011). Analysis of information sharing mechanism in the food industry green supply chain management and operation process. *Asian Agricultural Research*, 3(1812-2016-142862), 86-90.
- [10] Mengelkamp, E., Notheisen, B., Beer, C., Dauer, D., & Weinhardt, C. (2018). A blockchain-based smart grid: towards sustainable local energy markets. *Computer Science-Research and Development*, 33(1-2), 207-214.
- [11] Morkunas, V. J., Paschen, J., & Boon, E. (2019). How blockchain technologies impact your business model. *Business Horizons*, 62(3), 295-306.
- [12] Navadkar, V. H., Nighot, A., & Wantmure, R. (2018). Overview of blockchain technology in government/public sectors. *International Research Journal of Engineering and Technology*, 5(6), 2287-2292.
- [13] Niranjnamurthy, M., Nithya, B. N., & Jagannatha, S. (2019). Analysis of Blockchain technology: pros, cons and SWOT. *Cluster Computing*, 22(6), 14743-14757.
- [14] Peck, M. E. (2017). Blockchain world-Do you need a blockchain? This chart will tell you if the technology can solve your problem. *IEEE Spectrum*, 54(10), 38-60.
- [15] Puthal, D., Malik, N., Mohanty, S. P., Kougianos, E., & Yang, C. (2018). The blockchain as a decentralized security framework [future directions]. *IEEE Consumer Electronics Magazine*, 7(2), 18-21.
- [16] Saberi, S., Kouhizadeh, M., Sarkis, J., & Shen, L. (2019). Blockchain technology and its relationships to sustainable supply chain management. *International Journal of Production Research*, 57(7), 2117-2135.
- [17] Taleb, N. (2019). Prospective Applications of Blockchain and Bitcoin Cryptocurrency Technology. *TEM Journal*, 8(1), 48-55.
- [18] Visvizi, A., Lytras, M. D., Damiani, E., & Mathkour, H. (2018). Policy making for smart cities: Innovation and social inclusive economic growth for sustainability. *Journal of Science and Technology Policy Management*, 9(2), 126-133.
- [19] Wang, R., Lin, Z., & Luo, H. (2019). Blockchain, bank credit and SME financing. *Quality & Quantity*, 53(3), 1127-1140.
- [20] Yeoh, P. (2017). Regulatory issues in blockchain technology. *Journal of Financial Regulation and Compliance*, 25(2), 196-208.
- [21] Yi, S. U. N., Lingjun, F. A. N., & Xuehai, H. O. N. G. (2018). Technology Development and Application of Blockchain: Current Status and Challenges. *Strategic Study of CAE*, 20(2), 27-32.
- [22] Zhang, Y., & Wen, J. (2017). The IoT electric business model: Using blockchain technology for the internet of things. *Peer-to-Peer Networking and Applications*, 10(4), 983-994.

Internet of Things Utilization in Marketing for Competitive Advantage: An Organizational Capability Perspective

(Full Paper)

Wei-Hsiu Weng*, National Chengchi University, Taiwan, wengvictor@gmail.com

ABSTRACT

Innovative developments in the Internet of Things (IoT) have invoked tremendous attention from both academics and industries. Studies suggest that IoT not only serves as an innovative tool for enterprise operations but also triggers impacts on business performance. As researchers increasingly raise interest about IoT and its applications in marketing and competitive strategy, this study examines its direct and indirect managerial effects by investigating the link between IoT, marketing, and competitive strategy performance. From the organizational capability perspective, this study constructed a research framework in which marketing intelligence capability mediates the effect of IoT capability on business strategy performance. This research conducted an empirical survey and analyzed the data to test the hypotheses in the research framework. The results confirmed the partial mediating effect of marketing intelligence capability in the link between IoT capability and business strategy performance. The paper then discussed the test results and elaborated on the managerial implications.

Keywords: Internet of Things, marketing intelligence, competitive strategy, organizational capability.

*Corresponding author

INTRODUCTION

Recent development of the extensive global pandemic has caused business environments to change rapidly and enormously. To respond effectively to the changing internal situations and external environments, a firm must interact closely with changes through its distinctive capabilities to form a highly robust organization. Pursuing a robust organization makes a firm's organizational capabilities especially critical, because organizational capabilities are the source of competitive advantage (Barney, 1995; Day, 1994, 2011; Grant, 1991, 1996; Teece, Pisano, & Shuen, 1997).

Many organizations consider the evolution of the Internet of Things (IoT) as "the next big thing" of information technology (Borgia, 2014; Miorandi *et al.*, 2012). Firm managers expect the development of various IoT related technologies to affect enterprises' managerial paradigm and business strategy. IoT attracted attention as a possible source of strategic advantage for firms (Porter & Heppelmann, 2014). It may provide business opportunities for companies, and may even change the future market (Iansiti & Lakhani, 2014). Therefore, aligning with the development of IoT has become critical for the formulation and execution of a firm's business strategy. The perceived capability of IoT implies that firms make strategic decisions more efficiently. By employing IoT, firms should be able to recognize new business opportunities, identify possible threats, and maintain competitiveness. However, studies of the relationship between IoT and business capability are rare in the literature so far. To fill this gap, this study intends to investigate the link between IoT and business capability.

Moreover, a firm is a value chain with various value activities (Porter, 1985). Among these value activities, marketing plays a crucial role in shaping the overall business strategy of a firm (Day & Wensley, 1983; Dobni & Luffman, 2003). However, during abnormal time such as a disastrous pandemic, business operations of firms are severely restricted because of quarantine measures and traffic blocking. As a critical business function, marketing is also under serious restraint. Furthermore, in a firm's marketing operations, marketing intelligence is the foundation of overall marketing activities, because marketing decisions rely on the capability of acquiring and interpreting accurate marketing intelligence (Trainor, Krush, & Agnihotri, 2013). As IoT enabled products and services have the potential of transforming marketing paradigm (Bulearca & Tamarjan, 2010; Porter & Heppelmann, 2014; Zancul *et al.*, 2016), the objective of this research is to investigate the linkages among IoT, marketing intelligence and sustainable competitive advantage under uncertain situations. The paper begins with a review of the relevant literature about the relationships between the Internet of Things, marketing intelligence, and business strategy. Then it proposes a model that links these three variables. Following that, the paper describes the procedure that tests the model using a sample of Taiwanese companies with global operations. Finally, the paper presents the findings along with managerial implications and recommendations for future work.

LITERATURE REVIEW AND HYPOTHESES DEVELOPMENT

Internet of Things and Organizational Capability

Several researchers have elaborated on the technological features of the Internet of Things (Agarwal & Brem, 2015; Atzori, Iera, & Morabito, 2010; Borgia, 2014; Bradley *et al.*, 2015; Gubbi *et al.*, 2013; Krotov, 2017; Miorandi *et al.*, 2012; Porter & Heppelmann, 2015). These features are classified and summarized as follows.

- Ubiquitous sensing

This is the mechanism that the “things” or devices in IoT perceive the surrounding physical environment, detect and record the changes in the environment, and respond to the changes. Ubiquitous sensing is enabled by wireless sensor network (WSN) technologies (Borgia, 2014; Bradley *et al.*, 2015; Gubbi *et al.*, 2013).

- Pervasive connectivity
IoT contains multiple layers of communication networking infrastructure to provide the pervasive communications between people and people, people and things, and things and things, to form a smart environment (Atzori *et al.*, 2010; Gubbi *et al.*, 2013; Weng & Lin, 2015).
- Embedded computing
IoT devices contain embedded hardware and software to work intelligently within the environment. The embedded hardware includes processor chips, data storage units, and power units. The embedded software includes embedded operating systems, mobile apps, and middleware. In particular, IoT devices can be embedded further in other devices (Gubbi *et al.*, 2013; Krotov, 2017; Weng & Lin, 2014b).
- Real-time analytics
IoT monitored and detected information is invisibly embedded in the environment around users, results in the generation of big data in real-time, which is distributed, stored, processed, presented, and interpreted in a seamless, efficient, and easily understandable form (Gubbi *et al.*, 2013; Krotov, 2017; Weng & Lin, 2014c).
- Cloud support
IoT systems deploy cloud services to assist the processing and storage of IoT analytics, and provide IoT users ubiquitous access to supporting services initiated by IoT devices around the smart environment (Atzori *et al.*, 2010; Bradley *et al.*, 2015; Gubbi *et al.*, 2013; Weng & Lin, 2014a).
- Intelligent user interface
Visualizing, touching, and listening are critical for an IoT application as these functions allow the IoT users to be aware of the IoT environment. 3D viewing and printing technologies, personal mobile assistants, wearable devices, and augmented-reality systems provide a novel interface for users to interact with the smart environment (Bradley *et al.*, 2015; Gubbi *et al.*, 2013; Weng & Lin, 2014d).
- Interconnected smart products
IoT enables the evolution of various products such as smart home appliances, robots, drones, crewless cars, automated factory machines and business equipment, and many other innovative devices (Krotov, 2017; Miorandi *et al.*, 2012; Porter & Heppelmann, 2015; Weng & Lin, 2014b, 2015).
- Cyber-physical convergence
The convergence of computer network, telecom network, and IoT triggers further convergence of cyberspace and physical space, and results in various smart spaces, such as smart home, smart office, smart factory, smart laboratory, smart store, smart marketplace, smart hospital, smart museum and smart city (Agarwal & Brem, 2015; Bradley *et al.*, 2015; Gubbi *et al.*, 2013; Miorandi *et al.*, 2012).

In the information technology capability context, IoT capability refers to the firms’ ability to integrate resources and skills arising from IoT to align with the firms’ strategic directions (Bharadwaj, 2000; Grant, 1996). IoT capability enables an organization to exploit and incorporate the above IoT technological features for business value. By using IoT, firms can identify new business opportunities and potential threats, and maintain competitiveness, thus establishing the IoT capability to be a source of competitive advantage (Yu, Nguyen, & Chen, 2016). A firm with IoT capability is competent in developing or deploying IoT core components for business applications, making or using IoT connected products for business benefits, and implementing IoT enabled environments for business value (Porter & Heppelmann, 2014, 2015).

Internet of Things and Sustainable Competitive Advantage

From the strategic management perspective, cost leadership and differentiation are two essential approaches to competitive advantage and basic choices of business strategy (Porter, 1980; Porter & Millar, 1985). Furthermore, researchers have argued that cost leadership and differentiation are not mutually exclusive, but rather are compatible approaches to dealing with external situations, and a combination of strategies could lead to success in various circumstances (Hill, 1988; Li & Li, 2008; Murray, 1988). In the IoT context, whether a firm wants to achieve cost advantage, differentiation advantage, or a combination of both through its IoT capability is a strategic intent, which causes the firm to formulate and implement IoT facilitated cost leadership strategy, differentiation strategy, or a combination of both types of strategy.

Cost leadership strategy requires organizational capabilities to achieve operational efficiency, including time efficiency, cost efficiency, and flexibility. The problem is that employees have spare time and imperfect accuracy, and therefore, they are not very accurate at capturing information about things in the physical world. The IoT sensor technology enables connected devices to sense, observe, and understand the physical world – without the limitations of human entered data (Haddara & Elragal, 2015). Furthermore, enterprises will be flexible enough to respond to production changes swiftly with IoT capability. The functions of IoT-enabled smart factory can integrate technologies of many disciplines. IoT capability helps an enterprise to make extensive use of artificial intelligence, simulation, automation, robotics, sensors, data collection systems, and networks towards advanced engineering and precision machining. These systems make possible the establishment of efficient, collaborative, and sustainable industrial production to achieve sustainable cost advantage (Benias & Markopoulos, 2017).

Differentiation strategy requires organizational capabilities to achieve product or service uniqueness for higher customer premiums. Firms realize products or services differentiation through innovation or customization. IoT capability provides higher accuracy on analyzing and identifying distinctive customer preferences through hidden analytics of interconnected products. Sensor-based information collected through IoT embedded products covers actions of customer purchase and use, and can be analyzed to obtain a much more precise and complete picture of the customer's characteristics and preferences (Ng *et al.*, 2015). Smart laboratories can provide test fields for innovative products and services before delivery to customers. Customer feedbacks are collected and transmitted in real-time through various sensor networks and supportive cloud services for further refinement of innovation or customization. Thus IoT capability could expand opportunities for product or service differentiation, moving competition away from cost alone. This effect is particularly crucial under uncertainty. Therefore, this study proposes the following two hypotheses:

H1a. IoT capability is positively associated with cost performance under uncertainty.

H1b. IoT capability is positively associated with differentiation performance under uncertainty.

Internet of Things and Marketing Intelligence

Effective marketing requires adequate information for planning and allocating resources to different markets, products, territories, and marketing tools (Kotler, 1977). Marketing intelligence is systematically collected and extracted information for making marketing decisions. Marketing intelligence is a critical component for the overall marketing activities of a firm. Acquisition and effective use of marketing intelligence are vital in shaping the firm's sustainable competitive advantage (Jaworski & Kohli, 1993; Kohli & Jaworski, 1990). Marketing intelligence capability concerns a firm's ability to learn about customers, competitors, channel members, and the broader market environment in which it operates (Day, 1994; Morgan, Slotegraaf, & Vorhies, 2009).

IoT capability can enhance marketing intelligence capability because IoT capability enables a firm with a better ability to sense and collect information from customers and competitors (Yu *et al.*, 2016). IoT capability indicates the ability to merge the digital world with the world of things. It involves the ability of convergence of the manufacturing systems with the power of cloud computing, big data analytics, pervasive sensing, and internet connectivity (Agarwal & Brem, 2015). For a firm with IoT capability, large scale real-time customer surveys can be conducted with the assistance of sensing and recognition technology. Augmented reality enhanced user interface allows users to view and test products and services using their smartphones, tablets, or 3D viewing glasses. The big data from IoT connected products provide a clear picture of product use, showing the features customers prefer. By comparing usage patterns, firms can identify more precise market segmentation information (Porter & Heppelmann, 2015). Firms can then apply this knowledge to generate more valuable intelligence and develop more sophisticated pricing strategies that better match price and value at the market segment.

IoT capability also facilitates collaborations between firms and business partners. Information sharing in the IoT can occur among people, among people and things, and among things. Firms with IoT capability are more convenient to form virtual alliances or virtual groups with partners. These partners could be customers, suppliers, intermediaries, governments, and competitors, all of which are important in the IoT context (Yu *et al.*, 2016). Sensing a predefined incident is often the beginning for information sharing. Information sharing can enhance situational awareness and support collaboration (Lee & Lee, 2015). This cycle of sensing, sharing, and collaboration is the essence of marketing intelligence. As such, IoT capability can enhance a firm's marketing intelligence acquisition efforts, representing the extent to which they can generate and disseminate marketing intelligence, and which may lead to novel interpretations and recombination of prompt responses to marketing situations. Thus with IoT capability, a firm can transform marketing intelligence capability and enhance marketing results. In summary, we propose the following hypotheses:

H2. IoT capability is positively associated with marketing intelligence capability.

Marketing Intelligence and Sustainable Competitive Advantage

A business strategy includes mission and goal clarity, situation analysis, comprehensiveness of alternative evaluation, and strategy formation process (Slater, Olson, & Hult, 2006). A business strategy concerns the competitive positioning, market segmentation, and industry environment of a company (Porter, 1980). To survive, grow, and sustain, a firm needs to monitor its internal and external status for possible changes. Thus the formulation and execution of a business strategy rely heavily on the collection, extraction, analysis, interpretation, and prediction of internal and external status data of the company (Claver-Cortés, Pertusa-Ortega, & Molina-Azorín, 2012; McAfee & Brynjolfsson, 2012). Therefore, a firm's marketing intelligence capability is critical in facilitating its business strategy formation. Business strategies of most companies are frequently a combination of their intended strategies and the emergent strategies (Mintzberg, 1985). Business leaders need to analyze the status information of emergence and to make strategy adjustments when appropriate (Mintzberg & Waters, 1985). For this purpose, marketing intelligence capability is also essential as the capability for the strategic decisions to be accurately updated and aligned with competition changes (Aker *et al.*, 2016; Janssen, van der Voort, & Wahyudi, 2017).

Marketing intelligence capability enables a firm to acquire and analyze the cost structures and distinctive features of products and services of peers in the marketplace. It helps the firm to determine which market segments are suitable for cost leadership, and which market segments are feasible for differentiation. Marketing intelligence about cost analytics of all levels needs to be

collected and accurately analyzed for a firm to maintain a viable leading cost status. Marketing intelligence regarding customer preferences and distinctive features are required for a firm to determine the need to differentiate its products against the need to keep its cost structure under control in order to offer a unique product at a competitive price (Slater *et al.*, 2006; Xie *et al.*, 2016). In unusual events such as a serious epidemic, marketing intelligence capability is especially crucial for a firm to continue its marketing operation under uncertainty. Therefore, the author proposes the following two hypotheses:

H3a. Marketing intelligence capability is positively associated with cost performance under uncertainty.

H3b. Marketing intelligence capability is positively associated with differentiation performance under uncertainty.

Research Framework

Based on our proposed hypotheses, the research framework is illustrated in Figure 1.

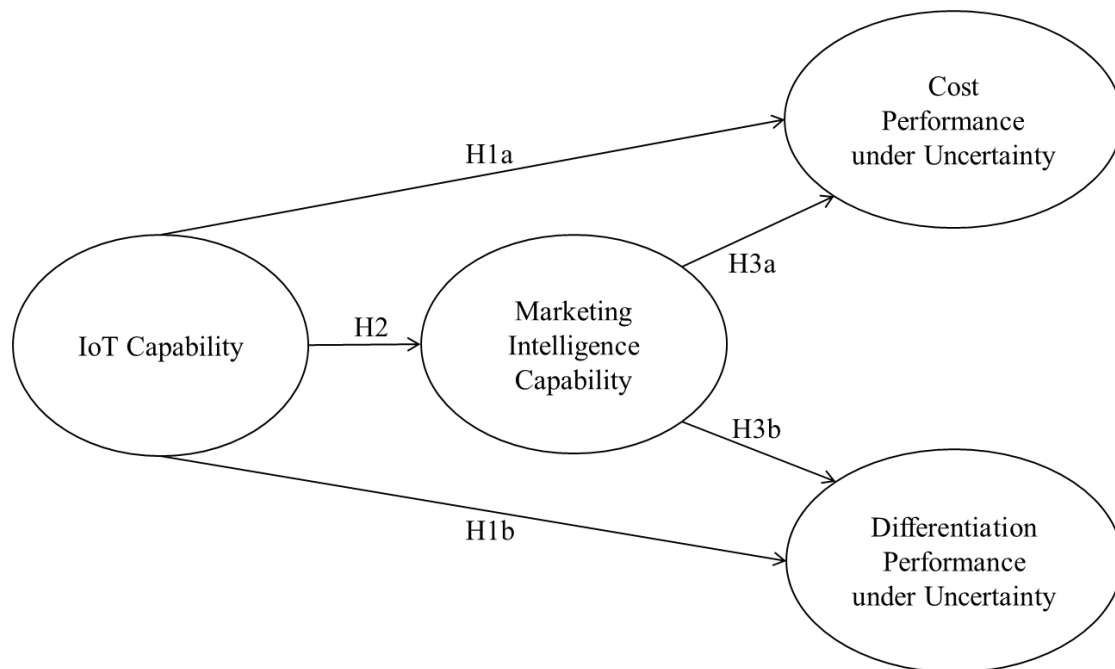

Figure 1: Research framework.

METHOD

Survey Instrument

The survey instrument uses questions derived from the literature on information technology capabilities, marketing capabilities, and Porter's typology of competitive strategies discussed previously. We operationalized the study variables by using multi-item reflective measures on a 7-point scale (1 – strongly disagree; 7 – strongly agree) (Jarvis, MacKenzie, & Podsakoff, 2003). Table 1 presents the construct and item description.

Table 1: Constructs and items used in the survey.

Construct	Items
IoT capability (IoT)	Following the definition of information technology capability by Bharadwaj (2000), a firm's IoT capability is measured here by its ability to develop or deploy IoT based resources, which include the tangible IoT resources, the intangible IoT resources, and the human IoT resources. The tangible IoT resources are tangible things such as IoT components, IoT connected products, and IoT enabled smart environments. The intangible IoT resources are assets such as knowledge, know-how, and synergy about IoT. The human IoT resources comprise technical and managerial IoT staffs. Thus we measure the core capability arising from IoT with three items according to the utilization of the three types of IoT based resources.
Marketing intelligence capability (MIC)	A firm's marketing intelligence capability concerns its competency in intelligence generation, intelligence dissemination, and responsiveness (Kohli & Jaworski, 1990; Kohli, Jaworski, & Kumar, 1993). Marketing intelligence capability is operationalized as the accessibility and utilization of resources and activities within a firm to collect and analyze market information and utilize it to develop effective marketing programs. The ability to effectively gather and disseminate customer and competitor information is critical for marketing intelligence capability (Kohli <i>et al.</i> , 1993; Narver & Slater, 1990). This four-item scale was from Vorhies, Morgan, and Autry (2009) and Trainor <i>et al.</i> (2013).

Cost performance under uncertainty (CSP)	The construct of cost performance under uncertainty was measured using four items that reflect the extent to which a firm performs a cost efficient strategy. The formation of a cost leadership strategy aims at achieving low manufacturing and distribution costs (Dess & Davis, 1984; Narver & Slater, 1990; Porter, 1980). The third item was the economic scale. A firm can usually lower costs through economies of scale or superior manufacturing processes (Porter, 1980, 1985). Finally, the formation of cost leadership often reflects a lower price of products or services (Dess & Davis, 1984; Robinson & Pearce, 1988).
Differentiation performance under uncertainty (DFP)	The construct of differentiation performance under uncertainty was measured using four items that reflect the extent to which a firm performs a differentiation strategy. Differentiation implies being unique or distinct from competitors by providing superior functionality or customized feature within products or services to customers (Porter, 1980; Wu, 2004). Extending Porter's business strategy framework, Miller (1988) discriminated differentiation strategy based on innovation from that based on intensive marketing (Miller, 1986, 1988). This distinction forms two items included in the construct.
Control Variables	Firm size, IT department size, and industry sector were used as control variables, as these variables have been noted in several studies to affect the deployment of information technologies (Liu <i>et al.</i> , 2010; Teo, Wei, & Benbasat, 2003).

Source: This study.

Sample and Data Collection

Enterprises operating in Taiwan were surveyed in order to test the hypotheses. A questionnaire designed following Table 1 above was implemented as the survey instrument. It was then pretested with 13 business executives and managers. The pretesting focused on instrument clarity, wording, and validity. Members of the pretesting sample were invited to comment on the questions and wording of the questionnaire. The comments of these respondents then provided a basis for revisions to the questionnaire to establish content validity.

A sample of 1,000 firms was randomly selected from the top 5,000 list of the largest companies in Taiwan published by a Taiwanese market research organization. Most of the companies on the list are public listed corporations with international operations. On the questionnaire we asked for top MIS managers or CIO level to answer our survey questions. The survey, which took three months to complete, was initially conducted by postal mail and e-mail, and then followed up with telephone calls and in-person visits. A total of 233 responses were received, of which 30 were unusable and eliminated. The remaining 203 responses were used in this study, for a response rate of 20.3%.

The mean differences between responding and non-responding firms were compared along with firm attributes using t-tests, and all statistics were non-significant ($p > 0.5$). Furthermore, the responses were classified into two groups to examine whether there was any response bias. The responses received during the first two months were classified as early returns, and those received during the last months as of late returns. The two groups were then compared for any significant difference in responses using the chi-square test of independence. No significant difference was found between these two groups, supporting that response bias is not an issue in this study (Armstrong & Overton, 1977).

RESULTS

Reliability and Validity

To test the hypothesized research model, partial least square - path modeling (PLS-PM) was performed (Ringle, Wende, & Will, 2005). Table 2 reports the quality indicators of the PLS-PM model.

Table 2: Constructs reliability and validity.

Variable	AVE	Composite Reliability	R ²	VIF
IoT	0.719	0.884		1.159
MIC	0.738	0.918	0.113	1.172
CSP	0.695	0.901	0.463	
DFP	0.690	0.899	0.471	

Source: This study.

The AVE (average variance extracted) values of the four variables are all above 0.50, indicating the acceptable explanation powers of the four latent variables towards their measuring items (Hair *et al.*, 2016). The composite reliability are all above 0.7. The values of R² of the three endogenous latent variables show medium predictability. The VIF (variance inflation factor) values of IoT and MIC are both less than 5.0, indicating low collinearity between the two variables (Hair *et al.*, 2016).

Table 3 summarizes the correlations among different factors. We also assessed discriminant validity based on the construct correlation that Campbell and Fiske (1959) proposed. The values in the diagonal are the square root of AVE (average variance

extracted), which should exceed the inter-construct correlations for adequate discriminant validity. The tests indicated acceptable results concerning discriminant validity.

Table 3: Construct correlation.

Construct	1	2	3	4	5	6	7
1. IoT	0.848						
2. MIC	0.336	0.859					
3. CSP	0.368	0.659	0.834				
4. DFP	0.371	0.668	0.621	0.831			
5. Firm Size	0.112	0.021	0.063	0.036	1.000		
6. IT Size	0.063	-0.067	0.017	-0.026	0.400	1.000	
7. Industry	0.041	-0.121	-0.034	-0.043	-0.083	-0.242	1.000

Source: This study.

Tests of Hypotheses

The computation result of the model using partial least square algorithm is shown in Figure 2. All of the hypotheses in the research model are tested significant, providing sufficient support to the hypotheses.

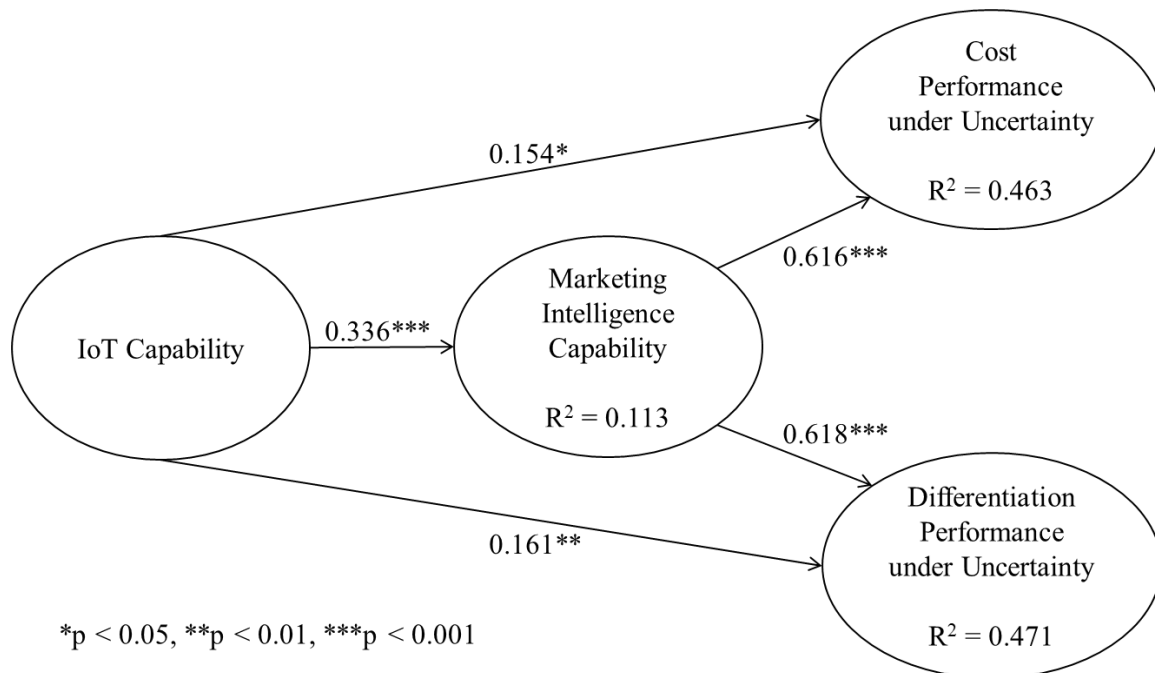

Figure 2: Results of research model.

Table 4 shows the significance test results of the path coefficients in the PLS model using bootstrapping. All of the path coefficients in the PLS model are tested significant.

Table 4: Significance tests of path coefficients.

Path	Path coefficient	t value	p value
IoT → CSP	0.154	2.508	0.013*
IoT → DFP	0.161	2.688	0.008**
IoT → MIC	0.336	4.519	0.000***
MIC → CSP	0.616	9.859	0.000***
MIC → DFP	0.618	9.373	0.000***

*p < 0.05, **p < 0.01, ***p < 0.001

Source: This study.

Table 5 shows the significance test results of the partial effects in the PLS model using bootstrapping.

Table 5: Significance tests of partial effects.

Path	Effect type	Effect	t value	p value	VAF
IoT → CSP	Total effect	0.361	4.767	0.000***	
IoT → DFP	Total effect	0.368	5.352	0.000***	
IoT → CSP	Effect without MIC	0.397	6.087	0.000***	
IoT → DFP	Effect without MIC	0.378	5.444	0.000***	
IoT → MIC → CSP	Indirect effect	0.207	4.453	0.000***	0.573
IoT → MIC → DFP	Indirect effect	0.207	4.411	0.000***	0.563

*p < 0.05, **p < 0.01, ***p < 0.001

Source: This study.

The VAF (variance accounted for) values for the two indirect effects in Table 5 are between 0.2 and 0.8, which verify the partial effects of MIC in the two links (Hair *et al.*, 2016; Preacher & Hayes, 2008).

The causal effects of paths in the model are summarized in Table 6.

Table 6: Causal effects of paths in the hypothesized model.

Hypothesis	Path	The causal effect from test results
H1a	IoT → CSP	Direct effect supported Partial mediation of MIC supported
H1b	IoT → DFP	Direct effect supported Partial mediation of MIC supported
H2	IoT → MIC	Direct effect supported
H3a	MIC → CSP	Direct effect supported
H3b	MIC → DFP	Direct effect supported

Source: This study.

DISCUSSION AND CONCLUSIONS

This study investigated the impact of a firm's IoT capability on business strategy performance and tested the possible mediating role of marketing intelligence capability. By supporting the research hypotheses, this study can help business managers and strategy practitioners realize the links between organizational capabilities and business strategy performance.

First, the cultivation of organizational capabilities, in general, is expected to enhance an organization's business strategies and further elevate its competitive advantage (Day, 1994; Grant, 1991; Ravichandran, Lertwongsatien, & Lertwongsatien, 2005). This study substantiates the positive correlation between a firm's organizational capabilities and business strategy performance. In particular, our results support the positive correlations between two different organizational capabilities and the performance of two types of business strategies. The findings demonstrate that both IoT capability and marketing intelligence capability can have positive effects on the performance of both cost leadership strategy and differentiation strategy, which could further lead to competitive advantage (Porter, 1980, 1985). Therefore, the study serves to inform business managers that firms should do more than just invest in innovative technologies or marketing operations. They need to identify and build distinctive capabilities and put them in productive use. This study suggests that both IoT capability and marketing intelligence capability are worthy of attention in this regard. The findings that these capabilities may impact business strategy performance indicate that their influence on a firm are cross-functional and may transcend managerial hierarchy.

Second, this study identifies a mediator in the association between IoT and business strategy performance. While IoT capability influences business strategy performance positively, our findings also point out that the link between IoT capability and business strategy performance is partially mediated by marketing intelligence capability. Our study is unique in that it explores the link between IoT capability and marketing intelligence capability. The results reveal the mediating role of marketing intelligence capability on the relationship between IoT capability and business strategy performance. For the partial mediation effect, both of the links between IoT capability and marketing intelligence capability and between marketing intelligence capability and business strategy performance need to be significant, and the influence of IoT capability on business strategy performance is alleviated with the presence of marketing intelligence capability (Baron & Kenny, 1986). That is, in

addition to the direct effect of IoT capability on business strategy performance, there is also an indirect effect through marketing intelligence capability. These two effects contribute to the total effect of IoT capability on business strategy performance. The extant literature seldom elaborates on what happens to the inside of a firm with the introduction of IoT. Most of the present research draws more attention to the analysis of how IoT could influence business performance. This study points out how IoT could influence the business strategy performance through the mediating role of marketing intelligence. Our findings support not only the marketing orientation concept of Jaworski and Kohli (1993), but also the hierarchy model of capabilities of Grant (1996). From the managerial implication perspective, the marketing department in a firm is skillful at sensing and understanding the outside environment. If a business strategy of a firm can fit into its surroundings, its performance is usually enhanced. Thus, a marketing department in a firm becomes critical for a firm to make its business strategies fit with its surroundings. Our findings suggest that IoT capability can facilitate the marketing department of a firm for the generation, dissemination, and analysis of marketing intelligence to shape the firm's business strategy for competitive advantage.

In essence, IoT capability and its output, pervasive sensing and connectivity with embedded analytics, enable firms to deploy and operate in smart environments and thus could enhance the functional level operations with efficiency and flexibility to achieve cost leadership or differentiation, or a combination of both. It is also because of the cross-functional nature of pervasive sensing and connectivity with embedded analytics, IoT capability can have a positive influence on some other organizational capabilities, such as marketing intelligence capability. Marketing intelligence capability and its output, marketing intelligence, enable firms to anticipate and understand better the customer needs and the competitive situation, to deal with this information faster, and to develop products and services with lower cost or with differentiated features, which empower firms to sustain a competitive advantage. In conclusion, during the recent abnormal time of global epidemic while in-person and face-to-face contacts are restricted and marketing activities are limited, our results indicate that IoT utilization for marketing intelligence provides a possible capability toward sustainable competitive advantage.

Further research efforts that focus on accumulating more empirical evidence for assessing and validating empirical data are recommended to overcome the limitations of the present study. Such research is required to address how other emerging technologies are related to business strategies and functional operations. For example, wearable interface technology (Chan *et al.*, 2012; Chen *et al.*, 2015; Gruebler, Berenz, & Suzuki, 2012; Weng & Lin, 2014d) and augmented reality technology (Chung, Han, & Joun, 2015; Meža, Turk, & Dolenc, 2015; Petersen & Stricker, 2015) have received inadequate attention from strategic considerations and organizational capability theories. Moreover, special attention could be focused on data collected in various sub-industries or specific contexts over an extended period. The analysis of these data may enable conclusions to be drawn about more generalized relationships among business-level strategy, functional-level strategy, and technology-based organizational capability.

REFERENCES

- [1] Agarwal, N., & Brem, A. (2015). Strategic business transformation through technology convergence: Implications from General Electrics industrial internet initiative. *International Journal of Technology Management*, 67(2/3/4), 196-214.
- [2] Akter, S., Wamba, S. F., Gunasekaran, A., Dubey, R., & Childe, S. J. (2016). How to improve firm performance using big data analytics capability and business strategy alignment? *International Journal of Production Economics*, 182, 113-131. doi:10.1016/j.ijpe.2016.08.018
- [3] Armstron, J. S., & Overton, T. S. (1977). Estimating nonresponse bias in mail surveys. *Journal of Marketing Research*, 14(3), 396.
- [4] Atzori, L., Iera, A., & Morabito, G. (2010). The Internet of Things: A survey. *Computer Networks*, 54(15), 2787-2805. doi:10.1016/j.comnet.2010.05.010
- [5] Barney, J. B. (1995). Looking inside for competitive advantage. *The Academy of Management Executive*, 9(4), 49-61.
- [6] Baron, R. M., & Kenny, D. A. (1986). The moderator–mediator variable distinction in social psychological research: Conceptual, strategic, and statistical considerations. *Journal of Personality and Social Psychology*, 51(6), 1173-1182. doi:10.1037/0022-3514.51.6.1173
- [7] Benias, N., & Markopoulos, A. P. (2017). A review on the readiness level and cyber-security challenges in Industry 4.0. Paper presented at the Design Automation, Computer Engineering, Computer Networks and Social Media Conference (SEEDA-CECNSM), 2017 South Eastern European.
- [8] Bharadwaj, A. S. (2000). A resource-based perspective on information technology capability and firm performance: an empirical investigation. *MIS Quarterly*, 24(1), 169-196.
- [9] Borgia, E. (2014). The Internet of Things vision: Key features, applications and open issues. *Computer Communications*, 54, 1-31. doi:10.1016/j.comcom.2014.09.008
- [10] Bradley, D., Russell, D., Ferguson, I., Isaacs, J., MacLeod, A., & White, R. (2015). The Internet of Things – The future or the end of mechatronics. *Mechatronics*, 27, 57-74. doi:10.1016/j.mechatronics.2015.02.005
- [11] Bulearca, M., & Tamarjan, D. (2010). Augmented reality: A sustainable marketing tool? *Global Business and Management Research*, 2(2/3), 237-252.
- [12] Campbell, D. T., & Fiske, D. W. (1959). Convergent and discriminant validation by the multitrait-multimethod matrix. *Psychological Bulletin*, 56(2), 81-105.

- [13] Chan, M., Esteve, D., Fourniols, J. Y., Escriba, C., & Campo, E. (2012). Smart wearable systems: current status and future challenges. *Artif Intell Med*, 56(3), 137-156. doi:10.1016/j.artmed.2012.09.003
- [14] Chen, B., Wang, X., Huang, Y., Wei, K., & Wang, Q. (2015). A foot-wearable interface for locomotion mode recognition based on discrete contact force distribution. *Mechatronics*, 32, 12-21. doi:10.1016/j.mechatronics.2015.09.002
- [15] Chung, N., Han, H., & Joun, Y. (2015). Tourists' intention to visit a destination: The role of augmented reality (AR) application for a heritage site. *Computers in Human Behavior*, 50, 588-599. doi:10.1016/j.chb.2015.02.068
- [16] Claver-Cortés, E., Pertusa-Ortega, E. M., & Molina-Azorín, J. F. (2012). Characteristics of organizational structure relating to hybrid competitive strategy: Implications for performance. *Journal of Business Research*, 65(7), 993-1002. doi:10.1016/j.jbusres.2011.04.012
- [17] Day, G. S. (1994). The Capabilities of market-driven organizations. *Journal of Marketing*, 58(4), 37-52. doi:10.2307/1251915
- [18] Day, G. S. (2011). Closing the Marketing Capabilities Gap. *Journal of Marketing*, 75(4), 183-195.
- [19] Day, G. S., & Wensley, R. (1983). Marketing theory with a strategic orientation. *Journal of Marketing*, 47(4), 79-89. doi:10.2307/1251401
- [20] Dess, G. G., & Davis, P. S. (1984). Porter's (1980) Generic strategies as determinants of strategic group membership and organizational performance. *Academy of Management Journal*, 27(3), 467-488. doi:10.2307/256040
- [21] Dobni, C. B., & Luffman, G. (2003). Determining the scope and impact of market orientation profiles on strategy implementation and performance. *Strategic Management Journal*, 24(6), 577-585.
- [22] Grant, R. M. (1991). The resource-based theory of competitive advantage: Implications for strategy formulation. *California Management Review*, 33(3), 114-135.
- [23] Grant, R. M. (1996). Prospering in dynamically-competitive environments: Organizational capability as knowledge integration. *Organization Science*, 7(4), 375-387.
- [24] Gruebler, A., Berenz, V., & Suzuki, K. (2012). Emotionally assisted human-robot interaction using a wearable device for reading facial expressions. *Advanced Robotics*, 26(10), 1143-1159. doi:10.1080/01691864.2012.686349
- [25] Gubbi, J., Buyya, R., Marusic, S., & Palaniswami, M. (2013). Internet of Things (IoT): A vision, architectural elements, and future directions. *Future Generation Computer Systems*, 29(7), 1645-1660. doi:10.1016/j.future.2013.01.010
- [26] Haddara, M., & Elragal, A. (2015). The readiness of ERP systems for the factory of the future. *Procedia Computer Science*, 64, 721-728.
- [27] Hair, Jr., J. F., Hult, G. T. M., Ringle, C., & Sarstedt, M. (2016). *A Primer on Partial Least Squares Structural Equation Modeling (PLS-SEM)*: Sage publications.
- [28] Hill, C. V. L. (1988). Differentiation versus low cost or differentiation and low cost: A contingency framework. *Academy of Management Review*, 13(3), 401-412.
- [29] Iansiti, M., & Lakhani, K. R. (2014). Digital ubiquity - How connections, sensors, and data are revolutionizing business. *Harvard Business Review*, November, 91-99.
- [30] Janssen, M., van der Voort, H., & Wahyudi, A. (2017). Factors influencing big data decision-making quality. *Journal of Business Research*, 70, 338-345. doi:10.1016/j.jbusres.2016.08.007
- [31] Jarvis, C. B., MacKenzie, S. B., & Podsakoff, P. M. (2003). A critical review of construct indicators and measurement model misspecification in marketing and consumer research. *Journal of Consumer Research*, 30(2), 199-218.
- [32] Jaworski, B. J., & Kohli, A. K. (1993). Market Orientation: Antecedents and Consequences. *Journal of Marketing*, 57(3), 53-70. doi:10.2307/1251854
- [33] Kohli, A. K., & Jaworski, B. J. (1990). Market Orientation: The Construct, Research Propositions, and Managerial Implications. *Journal of Marketing*, 54(2), 1-18. doi:10.2307/1251866
- [34] Kohli, A. K., Jaworski, B. J., & Kumar, A. (1993). MARKOR: A Measure of Market Orientation. *Journal of Marketing Research*, 30(4), 467-477. doi:10.2307/3172691
- [35] Kotler, P. (1977). From sales obsession to marketing effectiveness. *Harvard Business Review*, November-December, 67-75.
- [36] Krotov, V. (2017). The Internet of Things and new business opportunities. *Business Horizons*, 60(6), 831-841. doi:https://doi.org/10.1016/j.bushor.2017.07.009
- [37] Lee, I., & Lee, K. (2015). The Internet of Things (IoT): Applications, investments, and challenges for enterprises. *Business Horizons*, 58(4), 431-440. doi:10.1016/j.bushor.2015.03.008
- [38] Li, C. B., & Li, J. J. L. (2008). Achieving superior financial performance in China: Differentiation, cost Leadership, or both? *Journal of International Marketing*, 16(3), 1-22.
- [39] Liu, H., Ke, W., Wei, K. K., Gu, J., & Chen, H. (2010). The role of institutional pressures and organizational culture in the firm's intention to adopt internet-enabled supply chain management systems. *Journal of Operations Management*, 28(5), 372-384. doi:10.1016/j.jom.2009.11.010
- [40] McAfee, A., & Brynjolfsson, E. (2012). Big data - The management revolution. *Harvard Business Review*, 90(10), 60-68.
- [41] Meža, S., Turk, Ž., & Dolenc, M. (2015). Measuring the potential of augmented reality in civil engineering. *Advances in Engineering Software*, 90, 1-10. doi:10.1016/j.advengsoft.2015.06.005
- [42] Miller, D. (1986). Configurations of strategy and structure: Towards a synthesis. *Strategic Management Journal*, 7(3), 233-249.
- [43] Miller, D. (1988). Relating porter's business strategies to environment and structure: analysis and performance implications. *Academy of Management Journal*, 31(2), 280-308.
- [44] Mintzberg, H. (1985). Strategy formation in an adhocracy. *Administrative Science Quarterly*, 30(2), 160-197.

- [45] Mintzberg, H., & Waters, J. A. (1985). Of strategies, deliberate and emergent. *Strategic Management Journal*, 6(3), 257-272.
- [46] Miorandi, D., Sicari, S., De Pellegrini, F., & Chlamtac, I. (2012). Internet of things: Vision, applications and research challenges. *Ad Hoc Networks*, 10(7), 1497-1516. doi:10.1016/j.adhoc.2012.02.016
- [47] Morgan, N. A., Slotegraaf, R. J., & Vorhies, D. W. (2009). Linking marketing capabilities with profit growth. *International Journal of Research in Marketing*, 26(4), 284-293.
- [48] Murray, A. I. (1988). A contingency view of Porter's "generic strategies". *Academy of Management Review*, 13(3), 390-400.
- [49] Narver, J. C., & Slater, S. F. (1990). The Effect of a Market Orientation on Business Profitability. *Journal of Marketing*, 54(4), 20-35. doi:10.2307/1251757
- [50] Ng, I., Scharf, K., Pogrebna, G., & Maull, R. (2015). Contextual variety, Internet-of-Things and the choice of tailoring over platform: Mass customisation strategy in supply chain management. *International Journal of Production Economics*, 159, 76-87. doi:10.1016/j.ijpe.2014.09.007
- [51] Petersen, N., & Stricker, D. (2015). Cognitive Augmented Reality. *Computers & Graphics*, 53, 82-91. doi:10.1016/j.cag.2015.08.009
- [52] Porter, M. E. (1980). *Competitive Strategy*. New York: Free Press.
- [53] Porter, M. E. (1985). *Competitive Advantage*. New York: Free Press.
- [54] Porter, M. E., & Heppelmann, J. E. (2014). How smart, connected products are transforming competition. *Harvard Business Review*, 92(11), 64-88.
- [55] Porter, M. E., & Heppelmann, J. E. (2015). How smart, connected products are transforming companies. *Harvard Business Review*, 93(10), 96-16.
- [56] Porter, M. E., & Millar, V. E. (1985). How information gives you competitive advantage. *Harvard Business Review*, 63(4), 61-78.
- [57] Preacher, K. J., & Hayes, A. F. (2008). Asymptotic and resampling strategies for assessing and comparing indirect effects in multiple mediator models. *Behavior Research Methods*, 40(3), 879-891.
- [58] Ravichandran, T., Lertwongsatien, C., & Lertwongsatien, C. (2005). Effect of information systems resources and capabilities on firm performance: A resource-based perspective. *Journal of Management Information Systems*, 21(4), 237-276. doi:10.1080/07421222.2005.11045820
- [59] Ringle, C. M., Wende, S., & Will, A. (2005). *SmartPLS 2.0. M3*. Hamburg: SmartPLS.
- [60] Robinson, R. B., & Pearce, J. A. (1988). Planned patterns of strategic behavior and their relationship to business-unit performance. *Strategic Management Journal*, 9(1), 43-60.
- [61] Slater, S. F., Olson, E. M., & Hult, G. T. M. (2006). The moderating influence of strategic orientation on the strategy formation capability-performance relationship. *Strategic Management Journal*, 27(12), 1221-1231.
- [62] Teece, D. J., Pisano, G., & Shuen, A. (1997). Dynamic capabilities and strategic management. *Strategic Management Journal*, 18(7), 509-533.
- [63] Teo, H. H., Wei, K. K., & Benbasat, I. (2003). Predicting intention to adopt interorganizational linkages: an institutional perspective. *MIS Quarterly*, 27(1), 19-49.
- [64] Trainor, K. J., Krush, M. T., & Agnihotri, R. (2013). Effects of relational proclivity and marketing intelligence on new product development. *Marketing Intelligence & Planning*, 31(7), 788-806. doi:http://dx.doi.org/10.1108/MIP-02-2013-0028
- [65] Vorhies, D. W., Morgan, R. E., & Autry, C. W. (2009). Product-market strategy and the marketing capabilities of the firm: impact on market effectiveness and cash flow performance. *Strategic Management Journal*, 30(12), 1310-1334.
- [66] Weng, W. H., & Lin, W. T. (2014a). Development assessment and strategy planning in cloud computing industry. *International Journal of Electronic Commerce Studies*, 5(2), 257-266. doi:10.7903/ijecs.1158
- [67] Weng, W. H., & Lin, W. T. (2014b). Development assessment and strategy planning in mobile computing industry. Paper presented at the *2014 IEEE International Conference on Management of Innovation and Technology*, Singapore.
- [68] Weng, W. H., & Lin, W. T. (2014c). Development trends and strategy planning in big data industry. *Contemporary Management Research*, 10(3), 203-214. doi:10.7903/cm.12288
- [69] Weng, W. H., & Lin, W. T. (2014d). A scenario analysis of wearable interface technology foresight. Paper presented at *The International Conference on Electronic Business (ICEB)*, Taipei.
- [70] Weng, W. H., & Lin, W. T. (2015). A mobile computing technology foresight study with scenario planning approach. *International Journal of Electronic Commerce Studies*, 6(2), 223-232. doi:10.7903/ijecs.1242
- [71] Wu, J.-J. (2004). Influence of market orientation and strategy on travel industry performance: an empirical study of e-commerce in Taiwan. *Tourism Management*, 25(3), 357-365. doi:10.1016/s0261-5177(03)00144-4
- [72] Xie, K., Wu, Y., Xiao, J., & Hu, Q. (2016). Value co-creation between firms and customers: The role of big data-based cooperative assets. *Information & Management*, 53(8), 1034-1048. doi:10.1016/j.im.2016.06.003
- [73] Yu, X., Nguyen, B., & Chen, Y. (2016). Internet of things capability and alliance. *Internet Research*, 26(2), 402-434.
- [74] Zancul, E. d. S., Takey, S. M., Barquet, A. P. B., Kuwabara, L. H., Cauchick Miguel, P. A., & Rozenfeld, H. (2016). Business process support for IoT based product-service systems (PSS). *Business Process Management Journal*, 22(2), 305-323.

Issues and Path Selection of Artificial Intelligence Design Talents Training in applied Undergraduate Universities in Smart City

(Full Paper)

Lijun Xu*, Institute of Art and Design, Nanjing Institute of Technology, Nanjing, China,
xulijun@njit.edu.cn

Jianjun Hou*, Institute of Art and Design, Nanjing Institute of Technology, Nanjing, China,
178385883@qq.com

Zhe Chen, Institute of Art and Design, Nanjing Institute of Technology, Nanjing, China,
864871359@qq.com

Jun Gao, Siemens Ltd., China Jiangsu Branch Co., Ltd., Nanjing, China,
gaoshou729@163.com

ABSTRACT

The widespread popularity and application of artificial intelligence technology requires technological innovation, of which talent training is an important content. The lack of professional talents has greatly restricted the development of the artificial intelligence industry to some extent. How to train industrial design talents with comprehensive qualities of "artificial intelligence design talents" in universities has now become the most important topic. Carry out university teacher training based on the industrial design profession, carry out the "collaborative education" innovation model based on "university-enterprise-government", innovative ability and awareness training curriculum system, and use artificial intelligence talent training goals and curriculum system for the construction and practice of goals. Analyze the current plight of artificial intelligence design talent training in applied general universities, clarify the current types and status quo of artificial intelligence design talents, and propose specific ways to solve the current artificial intelligence design talent training. There are few relevant talents for artificial intelligence design professionals who can combine their ideas and technology in actual production. The lack of design talents has greatly limited the development of their industries to some extent. The current application-oriented undergraduates Colleges and universities should explore specific paths for the training of artificial intelligence design talents, and the construction and practice of related curriculum systems should also be gradually revised during practical exploration, so as to realize innovative education through educational innovation.

Keywords: Artificial intelligence technology, design talent training, curriculum system, teacher training

*Corresponding author

INTRODUCTION

In recent years, the Ministry of Industry and Information Technology has emphasized that the in-depth integration of artificial intelligence with the real economy and manufacturing, the development of smart products and smart equipment, and the promotion of the overall upgrade of our country's manufactured products and equipment to the "smart generation" is the implementation of "Made in China 2025" One of the keys. In the context of artificial intelligence, research on the cultivation of industrial design talents based on artificial intelligence technology is of great significance for the further development of intelligent design, industrial design transformation, humanized design, interactive design, and design service industries.

The term "artificial intelligence" was first proposed at the Dartmouth Society in 1956. Artificial Intelligence (AI) is a branch of computer science that explores the essence of intelligence, creating human intelligence that can respond in a way similar to the purpose of an intelligent machine (Pu, 2018). Artificial intelligence is the closest relationship between scientific and philosophical topics. Its research results bring together cognitions from psychology, linguistics, neuroscience, logic, mathematics, computer science, robotics, economics, sociology and other disciplines (Chen, 2017a; Chen, 2017b). The research of artificial intelligence is not only to make machines have the ability to solve problems, but also to pay attention to the research of machines with self-learning ability, so that machines can accumulate life experience and wisdom like intelligent creatures, constantly sum up lessons, correct mistakes, improve performance, and adapt.

Among them, training of personnel is an important content. Although artificial intelligence technology has been emerging in our country for some time, there is still a certain gap compared with some foreign developed countries. Among them, the shortage of professional design talents has greatly restricted the development of this industry to some extent. Among them, there are very few relevant talents who can combine ideas and technologies in actual production. Currently, applied undergraduate colleges and universities are actively exploring training programs for artificial intelligence design talents. In addition, our country's artificial intelligence technology also lacks some problems in terms of policies. Among them, the training and support of professional talents greatly restrict the development and progress of the industry. According to statistics

from relevant agencies, at this stage, our country has an urgent need for talents in the artificial intelligence industry. The smart manufacturing industry and IT communication industry have the greatest demand for talents in the application of artificial intelligence technology. Among them, the biggest demand for artificial intelligence design and application talents is the industry of industrial design and intelligent design, and this number is constantly increasing every year. Therefore, it is the goal of this research to clarify the types and status quo of the current artificial intelligence design talents, analyze the current application-oriented colleges and universities of artificial intelligence talent training, and propose a specific path to solve the current artificial intelligence technology talent training.

Intelligent tutoring systems may outwardly appear to be monolithic systems, but for the purposes of conceptualization and design, it is often easier to think about them as consisting of several interdependent components. Previous research by Woolf (Woolf, B. 1992) has identified four major components: the student model, the pedagogical module, the domain knowledge module, and the communication module. We have identified a fifth component, the expert model. Woolf includes this component as part of the domain knowledge, but we feel that it is a separate entity.

DEMAND TYPES OF ARTIFICIAL INTELLIGENCE DESIGN TALENTS

In the past two years, the artificial intelligence industry has developed rapidly. Technically, from the application of single-point technology such as speech control and face recognition, to the multi-modal computing design interaction industry that integrates vision, voice, and semantics; in the application, the historical transformation power of artificial intelligence is accelerating its penetration into all walks of life. From product services, to production, operation, and decision-making, it plays an effective role in reducing costs and risks, shortening processes, bringing value-added income, and improving the production efficiency of enterprises. In terms of policies, artificial intelligence has also risen to the country’s strategic position. Relevant policies have appeared frequently to encourage industrial development from the national level (Yang, Ma & Sun, 2017). The troika of technological development, application landing, and policy support jointly drives the rapid development of artificial intelligence. Artificial intelligence changes the way we interact with machines, affects our lives, and redefines our relationship with machines. In the era of artificial intelligence, the transformation of the industrial design industry is not an evolution, but a reconstruction. It will reconstruct the tools, productivity, life and even machine aesthetics around us (Shan, 2017).

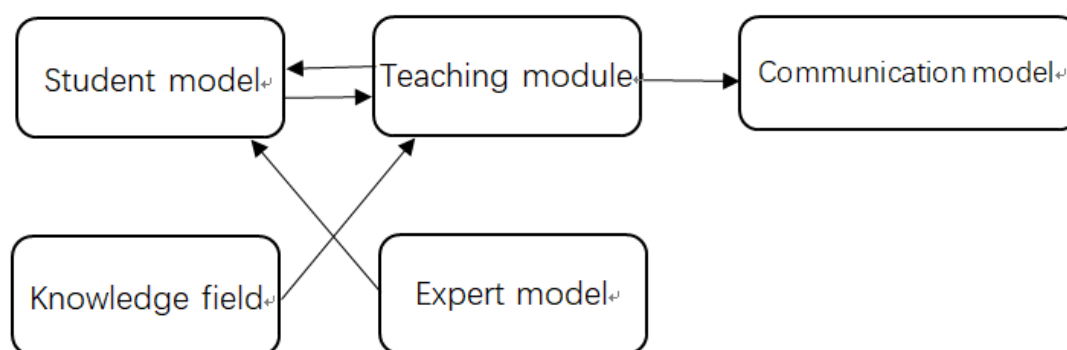

Source: This study.

Figure 1: Component interaction in intelligent teaching system

Within education curricula, Information Technology has made a great impact expedited by the advent of the World-Wide-Web and the consequent cultural information explosion. IT is a generic expression that can include any form of technology (equipment and technique) used by people to collect, store, control, generate and communicate information. It is clear that the advance of AI technology has been assisted by developments in Information. Chen (2017) Technology and many parallels can be drawn between these sciences. ‘Smart Technology’ is an unfortunate term that has been used in a somewhat cavalier manner, mainly due to media hype and commercial exploitation. In the mid-Eighties the development of shape memory alloys led to the tag ‘Smart Materials’ (Weiss, 2000). This was followed by ‘Smart Cards’ a simple memory device on a piece of plastic the size of a credit card which contained user profiles to operate user dependent machinery such as bank teller machines. Since then a whole manner of devices and products have been designed and marketed bearing the label ‘smart’, or even more misleading, ‘intelligent’. There are examples where IT has been merged with common domestic products, for instance by allowing Internet access via an LCD screen in the door of a microwave, or by installing a bar code reader and Internet access in a fridge, whereupon these humble kitchen appliances are apparently rendered ‘intelligent’. A common misconception is that AI and Smart technology is one and the same thing. The understanding and appreciation of AI as a philosophical science and an engineering discipline should, however, refute this, e.g., Figure 1 provides a view of the interactions between the modules. The proposed model illustrated in Figure 1 aims to create a more usable definition for distinguishing AI and Smart Technologies

from an application based engineering perspective. Beal (2013) If we consider Tesler’s theorem then legitimate AI areas, in both high and low level techniques, are shown as future research goals. Advances in AI research are disseminated through to applications research. Finally, proven techniques are integrated into commercially viable designs at the product development stage. Referring back to Tesler’s Theorem, at the point of accomplishing the technique it can no longer be considered legitimate AI. What remains are tried, but possibly not thoroughly tested, techniques that could be considered to be within the realm of Smart Technologies.

For the purpose of the model e.g., Figure 2: Artificial intelligence in the new era, only those products resulting from the direct consequence of AI research and its applications are considered. The model, however, is considered valid for such areas as wearable technology where IT and programmability is integrated into textiles and garments (Lu, 2019).

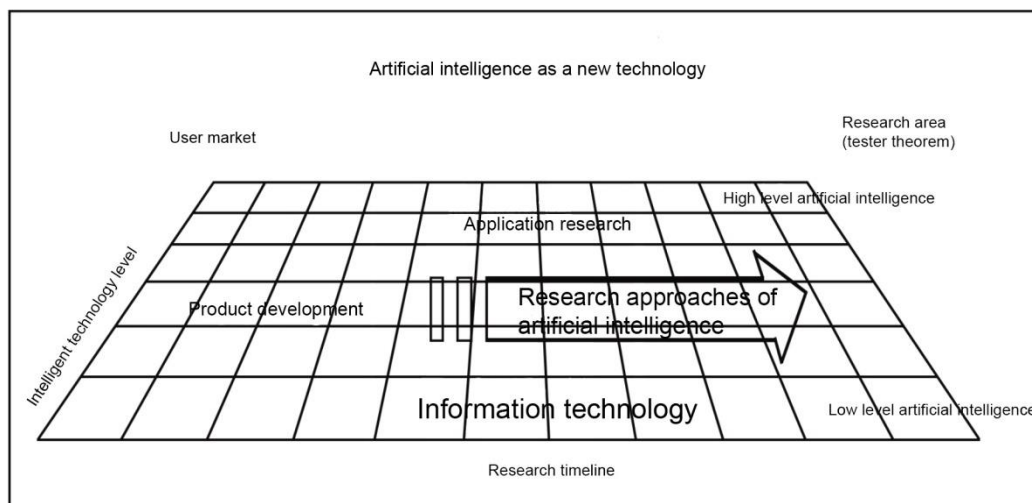

Source: This study.

Figure 2: Artificial intelligence in the new era

At this stage, in dealing with artificial intelligence application talents, it is necessary not only to increase the training of talents and technologies, but also to keep pace with the times, but also to have detailed plans and clear goals to ensure that this professional talent can be supplemented. In addition, artificial intelligence is also a highly applied professional subject. The main framework should be constructed based on market conditions and school-enterprise integration. The ideological line must be correct, and the requirements of social enterprises for this talent must not be ignored. Do not follow the trend blindly and radically. We must deal with it based on the facts and analyze specific issues. Reasonably arranging the school-enterprise training of design talents for production, study and research also plays a big factor, and its effect cannot be ignored. The current international classification of demand for artificial intelligence talents mainly includes the following types: AI design theory application talents, AI technology application talents, AI technology management talents, AI education and teaching talents, AI design and development talents. Each type has certain roles and skills, which are classified in the following table.

WHY DO DESIGNERS NEED TO KNOW ABOUT AI AND SMART TECHNOLOGY?

The commercial implications of using AI technology to create a unique selling feature is a familiar theme in product design, but, the important factors on how best to include AI techniques in products to improve usability (Xie et al., 2019), are ill-defined. Factors including the potential users’ perception and understanding of the technology alongside their confidence in depending upon such products are presently rarely considered. Gaining the confidence of users’ needs to be a task of principle in ensuring successful design of interactive products. It can be seen within present consumer products that simple automation features can cause the user frustration and annoyance. Auto-focusing cameras, auto text formatting within software packages, voice-activated (Tan, 2017) controls and speech generating alarms are examples of where the intended added functionality can ultimately result in user aggravation.

In terms of usability, AI can be viewed as a method for supporting a working dialogue with a product. Establishing the dialogue need not, therefore, be just an ergonomic relationship, effective interface design and degrees of controlled automation, it can also encompass the complex manipulation of information and the interaction with embedded knowledge. There is no inherent intelligence within a machine and it is left to the designer, of both hardware and software, to artificially create this attribute. It is, however, extremely rare for product designers to become involved with this level of technical engineering detail. But the combination of hardware, software and AI techniques is what endows smart products with functionality. Knowledge of the capabilities and limitations of the technology will enable product designers to be more creative and innovative and ensure the design of more successful interactive products.

Huang (2016) AI researchers have acknowledged that there is a noticeable lack in communication between AI developers and designers wishing to apply the technology. At a recent international workshop to discuss the acceptability of specific state of the art AI techniques in industry, it was noted that the development of usable systems was significantly hindered by failures in recognizing the importance of human interaction issues. The interaction issues are not the sole responsibility of ergonomists and designers, and it is also a necessary consideration for computer scientists, and AI developers. Furthermore, to ensure the success of smart products, it will be an ever-increasing responsibility of designers to be able to find common ground with software engineers, computer scientists and electronics engineers, e.g., Table1: Demand of International Classification of Artificial Intelligence Talent.

Table1: Demand of International Classification of Artificial Intelligence Talent

Talent type	Technical	Applied	Managerial	Educational
Role play	AI theory, technology, software, programming innovation	AI design, data, technology application and improvement	Innovation and practice of AI business model	AI education concept, all kinds of personnel training, professional construction, competition and competition
Skills	Proficient in AI theory, technology, programming, software, equipment, communication and other knowledge, with original consciousness and ability.	Master the technology of product design, software programming, material preparation and testing, data processing, equipment operation and transformation, and have strong innovation and practice ability.	Familiar with the basic knowledge of AI technology, familiar with the operation system and basic mode of industrial chain, have the basic skills of market and business management, and have the awareness of business innovation.	Familiar with the basic knowledge of AI technology, familiar with the basic theory and method of education and teaching, master the professional construction, curriculum, teaching organization and management methods, and have the ability of textbook compilation, teaching implementation, training management.

THE TRAINING DILEMMA OF ARTIFICIAL INTELLIGENCE DESIGN TALENTS

Artificial intelligence technology has developed rapidly in recent years, but it belongs to an emerging field after all, with a relatively short development time and many technical problems. For a long time, artificial intelligence design and machine learning capabilities have been a "bottleneck" in the field of artificial intelligence. On the one hand, the ability of machine learning is limiting the development of artificial intelligence and machine learning; on the other hand, given the close relationship with other fields, this requires researchers to train machine learning while the development of other talent fields can be used in new learning algorithms. And other areas of learning institutions have discovered, thereby promoting new development in the field of talent cultivation intelligence.

The target positioning of artificial intelligence design talent training is not accurate.

Through a series of popular science surveys, for related industries in our country, our country’s artificial intelligence industry is still in the initial stage of development, although the field of artificial intelligence technology is in all walks of life in our country All are involved and applied very quickly, but there is still a certain distance from the relatively mature AI technology abroad. In addition, our country currently has no clear standards for the formulation of artificial intelligence industry standards. It is still in an embryonic state and needs further development. The promotion of the cultivation of artificial intelligence design talents in colleges and universities has a profound and indelible impact. At this stage, the artificial intelligence technology in various universities in our country is also in a state of crossing the river by feeling the stones. A considerable number of colleges and universities are still in a blank state in the application and cognition of this technology. The most important thing is that they have not formulated training plans for design talents in this area. In addition, there is a lack of resources for talent training. The resulting series of problems also brought embarrassment to the recruitment of related AI companies: On the one hand, the design talents trained by the school lack a certain amount of practical training in the design and development of smart

products, and also lack long-term effective training programs; on the other hand, the popularity of our country's domestic artificial intelligence industry is still far Not enough, the technology is relatively immature, and there are not many jobs compared to other mature majors. The requirements for design talents are very high, so the prospects are not optimistic. From an economic point of view, schools spend millions to establish artificial intelligence technology laboratories, artificial intelligence research institutes, etc. However, there are few applications that can truly integrate teaching, and the quality of student sources cannot keep up. Restrictions on industry development, our country also does not pay enough attention to artificial intelligence design and application talents, and it is far from enough in the training and promotion of related artificial intelligence technology. There is a big gap in the design and development of artificial intelligence related software, programming and other courses, the design and development of intelligent products, and the application and practice of foreign cutting-edge artificial intelligence technology. There is also a gap between the artificial intelligence professional education of engineering majors in universities and the application needs of enterprises, and there is a lack of clear and reasonable positioning in the training of talents. Therefore, the school's senior management will also consider whether the training of artificial intelligence design talents in the school is feasible and effective.

The dilemma of artificial intelligence teaching and research faculty

At present, the application of artificial intelligence in our country is still immature. Most domestic colleges and universities are unable to introduce relevant artificial intelligence equipment due to the backwardness of experimental equipment and the high cost of professional equipment. Artificial intelligence is an emerging industry, and the design colleges of domestic universities do not have a clear division of disciplines. The resources for the training of artificial intelligence design talents are relatively scarce, and most colleges and universities are mostly teachers in engineering, computer science, communications and other professional teachers, and lack certain AI-related companies' market experience and educated students. It is difficult to connect with the emerging AI industry in the future. They also have teaching blind spots in intelligent design products and other reasons, and cannot guarantee the better development and application of artificial intelligence technology in intelligent products. In addition, the lack of multidisciplinary collaborative innovation among universities and the lack of interdisciplinary scientific research topics restrict the emergence of artificial intelligence compound design talents. After investigation and research, the current domestic correlated artificial intelligence design teachers are mostly group scientific research teachers. They lack a certain amount of practical experience in AI companies. In addition, traditional design companies also lack a certain degree of knowledge and understanding of artificial intelligence, and even less Practical application, it is unable to provide effective practical innovation guidance. Lu (2015) As artificial intelligence is a new type of industry and is more closely integrated with computer majors, design students have insufficient awareness of this, and only know that it is a new and fashionable "synonym" of computer programming. Fewer; the lack of resources for smart designers has led to an embarrassing state of unmanned application implementation even if universities have the ability to introduce various artificial intelligence facilities and technologies. The final result is that the design majors of various colleges and universities pay more attention to this than "hot pursuit". The students who are educated to do artificial intelligence-related design have a conceptual framework for the design, and there is no feasibility of implementing technical solutions. It is difficult to connect with AI companies in society.

The mechanism for training artificial intelligence design talents is unsound

According to relevant statistics, our country's shortage of artificial intelligence design talents is as high as one million, among which artificial intelligence application design talents are the most prominent. As a new industry that is emerging, its coverage is very wide and the lack of relevant design talents is beyond our imagination. For example, the artificial intelligence industry needs to continuously develop some intelligent software, digital technology, machine learning, etc. to meet the needs of today's society. At this stage, our country has some shortcomings in the training of application-oriented artificial intelligence design talents. Most domestic colleges and universities have little understanding of artificial intelligence intelligent design, and there are no training programs for related design talents. The talent mechanism is quite lacking. In addition, most colleges and universities follow the traditional school-running philosophy and focus on the cultivation of academic talents. The current shortage of intelligent design talents can also be confirmed and understood.

Providing appropriate information and guidance for fast-developing and commercially competitive fields may become a major obstacle for educators. Due to the conflicting agendas of intellectual property and research and dissemination, the transfer of technology from industry to education (and even from education to industry) often lacks the momentum needed to support this initiative. However, in the field of higher education in industrial design, because design solutions are often encouraged to incorporate more "close to market" attributes, institutions are often in a good position to take advantage of industrial cooperation. Some research groups in the field of artificial intelligence believe that exposing students to cutting-edge technology, its foundation, use, and development can stimulate and produce innovative and technologically advanced design solutions for practical problems. In addition, some research institutions acknowledge that education plays an important role in defining and advancing certain technologies used in the industry, because today's students may be the final users and

developers of future technology. It is envisaged that the development of design talents can be accelerated by introducing artificial intelligence in the early stages of student education.

THE TRAINING PATH OF ARTIFICIAL INTELLIGENCE DESIGN TALENTS

With the development of emerging technologies in the "Industry 4.0" era, the development and wide application of artificial intelligence technology, as the closest relationship between scientific and philosophical themes, its research results are gathered from psychology, linguistics, neuroscience, logic, mathematics, Computer science, robotics, economics, art and other disciplines. In the field of industrial design in the future, the greatest convenience that artificial intelligence brings to designers is that it can replace tedious and inefficient repetitive work, as well as some fixed and conventional artistic expression methods. From the perspective of most people's definition of art, the important thing that distinguishes designers from computers is that computers do not have "imagination", so artificial intelligence cannot replace designers at present, but works in collaboration with designers (Liu, Yan & Chen, 2016).

"Collaborative innovation" in the intelligent age leads the cultivation of artificial intelligence design talents

Construct application-oriented undergraduate colleges with an innovative model of "collaborative education" of "university-enterprise-government". The "collaborative education" innovation model of "university-enterprise-government" is an extension of the current university-industry-research combination. "Industry" cannot be separated from specialized artificial intelligence design talents who master knowledge; "research" also needs to rely on professionals who master artificial intelligence technology and technical knowledge. University topics come from production and life practice; "learning" must be linked to artificial intelligence. The practical application of the design requires attention to the research results of the latest artificial intelligence technology. Linking "university-enterprise-government" and taking the road of "industry-university-research" in the new intelligent era will inevitably improve the quality of talent training in applied undergraduate colleges. However, the three organizations of "industry", "learning" and "research" have their own tasks. Clarifying the interests of all stakeholders is the starting point for deepening the "collaborative education" innovation model of "university-enterprise-government". Enterprises need to combine their related interests in the innovation of artificial intelligence technology, the upgrading of artificial intelligence products, and the provision of artificial intelligence design talents and employee training that are closely related to enterprise production; the fundamental interest of applied undergraduate colleges lies in the training of artificial intelligence-related students. Become an applied design talent welcomed by enterprises and society. Based on this, in the era of intelligence, applied undergraduate colleges and universities must deepen the "collaborative education" innovation model of "university-enterprise-government" and must cooperate closely with enterprises and governments to get out of the original plight of industry-university-research cooperation.

Teacher training of artificial intelligence technology in the field of college design

In order to support the construction of the faculty for the training of artificial intelligence design talents in colleges and universities, relevant enterprises that carry out collaborative education innovation models with colleges and universities need to hold regular seminars for teachers of artificial intelligence teaching and research and enterprise technical personnel. Relevant universities need to hold high-level seminars and research classes related to artificial intelligence from time to time, invite university teachers and experts in artificial intelligence technology to participate, exchange and learn with each other, research and discuss the curriculum and target positioning of artificial intelligence design talent training. So as to meet the social needs of adapting to talent training.

College education is the main method of educating talents, and most students are trained in this way. Therefore, the physical and intellectual education of educating talents should be developed at the same time. Research on learning science and neuroscience provides basic insights into the complexity of learning and the processes behind learning, and provides clues for further improving individual teaching. For example, when students learn to motivate and challenge group projects in a team, they learn more; when they immediately apply what they have learned, they retain more; when they get from a quick-reacting mentor, they will learn more when they help, and these methods reflect a deep understanding of the learner's background, strengths and weaknesses.

Applying this new insight about human learning in the digital learning environment of teacher training requires a deeper understanding of teachers' cognition, including more effective constructivism and active teaching strategies. Artificial intelligence technology is essential for developing representations and reasoning about these new cognitive insights, providing a richer appreciation for how teachers lead students in learning, and measuring collaborative activities. Tan (2017) Artificial intelligence will also become a game changer in education. In fact, education and artificial intelligence can be regarded as the same two-sided coin: Education helps students learn and expand the knowledge accumulated by society. Artificial intelligence provides technology to better understand the mechanisms of thought, knowledge and intelligent behavior.

Establish a talent training goal and curriculum system designed with artificial intelligence

According to the specifications of talent training, application-oriented general undergraduate colleges need to train artificial intelligence application design talents, that is, to transform scientific principles into the design of artificial intelligence products; from the development trend of modern vocational and technical education in developed countries and regions, artificial intelligence The training of design talents can be at the undergraduate level and level, and it is necessary to train students to have the ability to comprehensively apply to solve the development and application of artificial intelligence products, and to design and innovate artificial intelligence technology. This target positioning is to solve the overall requirement of the current application-oriented undergraduate colleges with a poor target positioning of artificial intelligence design talents. From the perspective of the formulation of the curriculum system, we need to get rid of the skill training-centered curriculum system with higher education institutions, and at the same time change the curriculum system for academic talent training based on theoretical knowledge innovation, so as to build an artificial intelligence technology application (Yin, Ren & He, 2008). The curriculum system of applied general undergraduate colleges with design ability as the core, construct a curriculum system diagram as follows, Figure 3: Knowledge structure diagram of the "trinity" artificial intelligence curriculum system:

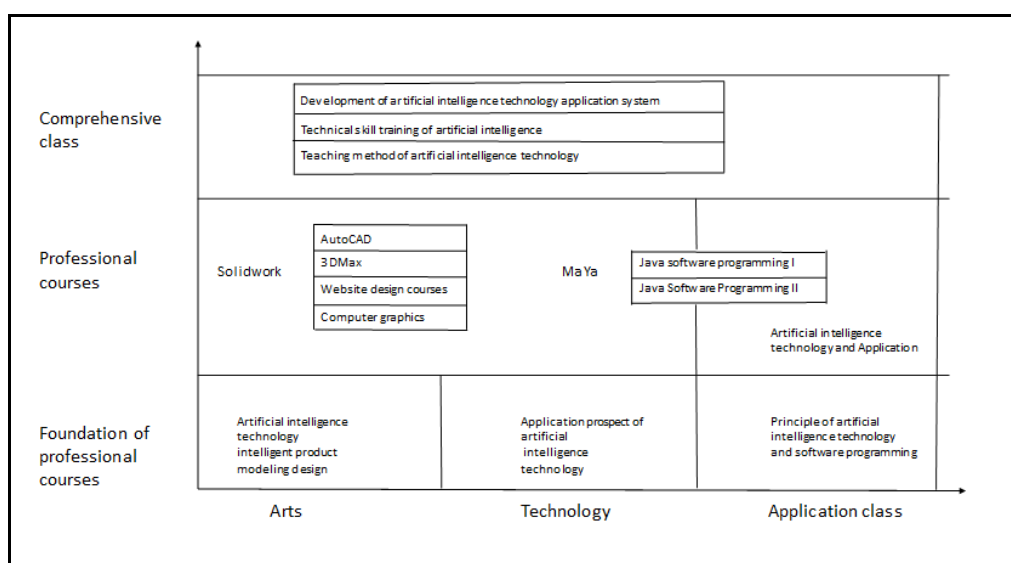

Source: This study.

Figure 3: Knowledge structure diagram of the "trinity" artificial intelligence curriculum system

CONCLUSION

Intelligent tutoring systems have been shown to be highly effective in increasing student motivation and learning. In designing these systems, it is useful to view them as being composed of five components: the student model, the pedagogical module, the domain knowledge, the communications module, and the expert model. Research has been done on each of these modules, but only a few are very well understood. Specifically, incorporating multiple teaching strategies in the pedagogical module is a large open research question.

In higher education, encourage the introduction of new cutting-edge technologies. If more and more attention is paid to the design of functional products in the education of design academies, then design students must obtain a solid foundation in the basic elements of intelligent technology. The research of artificial intelligence needs to pay attention to an eclectic knowledge system. There are few relevant talents for artificial intelligence technology professionals who can combine their ideas and intelligent design in actual production. The lack of talents to some extent has greatly limits the development of the artificial intelligence industry. At present, applied undergraduate colleges and universities should explore specific paths for the cultivation of artificial intelligence design talents, and the construction and practice of related curriculum systems should also be gradually revised during practical exploration, so as to realize innovative education through educational innovation.

Taking industrial design as the carrier, launching the "collaborative education" innovation model based on "university-enterprise-government", and "collaborative innovation" leading the training of artificial intelligence talents; developing innovation ability and awareness training curriculum system, and conducting university teacher training; Practice with the goal of artificial intelligence design talent training and curriculum system. Clarify the current types and status quo of artificial intelligence design talents, analyze the current application-oriented colleges and universities of artificial intelligence talent training, and propose specific ways to solve the current artificial intelligence design talent training.

ACKNOWLEDGMENT

This work is partially supported by the Jiangsu Province University philosophy and social science research 2019 major project, "Human-computer interaction design research based on artificial intelligence technology" (Project No. 2019 SJZDA118); and the Higher Education Research Project of Nanjing Institute of Engineering in 2020, "Research on Cultivating Path of Artificial Intelligence Design Applied Talents" (Project No. 2020YB17); and Youth Fund for Humanities and Social Sciences Research of the Ministry of Education (Project No. 20YJC760030); and the 2020 Jiangsu Province College Students Innovation and Entrepreneurship Training Project: "Research on the application of parametric design method in the design of epidemic prevention products in smart city" (Project No. 202011276028Z).

REFERENCES

- [1] Beal, C. R. (2013). AnimalWatch: An intelligent tutoring system for algebra readiness. In R. Azevedo and V. Aleven (Eds.) *International Handbook of Metacognition and Learning Technologies* (pp. 337-348). Springer, New York, NY.
- [2] Chen, G. B. (2017a). Think for design from the evolution of product. *Industrial Design*, 11, 65-66. doi: 10.3969/j.issn.1672-7053.2017.11.027 (in Chinese).
- [3] Chen, Q. J. (2017b). Future design, peer with artificial intelligence. *Art Observation*, 10, 16-17. doi: 10.3969/j.issn.1006-8899.2017.10.006 (in Chinese).
- [4] Huang, R. (2016). Exploration on the teaching reform of interactive design course of product design specialty in the era of Internet of things. *Art and Design (Theory)*, 2(07), 139-141. doi: 10.16824/j.cnki.issn10082832.2016.07.051 (in Chinese).
- [5] Liu, G. F., Yan, R. A., & Chen, X. L. (2016). Research on the development strategy of "industry 4.0" industrial cluster in China. *Modern Management Science*, 7, 18-20. doi: 10.3969/j.issn.1007-368X.2016.07.006 (in Chinese).
- [6] Liu, T., & Gao, L. M. (2016). Development trend of open innovation in the era of big data. *Scientific Research Management*, 37(07), 1-3. doi: 10.19571/j.cnki.1000-2995.2016.07.001 (in Chinese).
- [7] Lu, Y. X. (2015). Leading "made in China" with "innovative design". *Chinese Science and Technology Industry*, 12, 18-19. doi: 10.16277/j.cnki.cn11-2502/n.2015.12.004 (in Chinese).
- [8] Lu, Y. X. (2019). Research on the competitiveness of innovative design. *Journal of Machine Design*, 36(01), 1-4. doi: 10.13841/j.cnki.jxsj.2019.01.001 (in Chinese).
- [9] Pu, Y.L. & Chen, S. (2018). Research on knowledge acquisition technology in artificial intelligence. *Electronics World*, (01), 8-10. doi: 10.19353/j.cnki.dzsj.2018.01.002 (in Chinese).
- [10] Shan, Y. (2017). Application of "industrial 4.0" core technology in cultural industry. *Journal of Dongguan Institute of Technology*, 24 (02), 79-84. doi: 10.16002/j.cnki.10090312.2017.02.015 (in Chinese).
- [11] Tan, J. R. (2017). Key technology and development trend of intelligent manufacturing and robot application. *Robot Technique and Application*, (03), 18-19. doi: 10.3969/j.issn.1004-6437.2017.03.007 (in Chinese).
- [12] Tan, J.R., Zhang, S.Y. & Xu, J. H. (2016). *Case Study on Innovative Design of Manufacturing Equipment*. (pp. 25–56). Beijing: China Science and Technology Press.
- [13] Weiss, M. (2000). *Data Structures and Problem Solving Using C++*. (pp. 3–44). Pearson Education Inc.
- [14] Woolf, B. (1992). AI in Education. In S. Shapiro (Ed.) *Encyclopedia of Artificial Intelligence*, John Wiley & Sons, Inc., New York, pp. 434-444.
- [15] Xie, M. M., Xia, Y., Pan, J. F. & Guo, J.F. (2019). Artificial intelligence, technological progress and low skilled employment: An Empirical Study Based on Chinese manufacturing enterprises. *Chinese Journal of Management Science*, 12 (09). doi: 10.16381/j.cnki.issn1003-207x.2019.1251 (in Chinese).
- [16] Yang, S.H., Ma, G. C. & Sun, X. (2017). The reform and development of open product design in the big data era. *China CIO News*, (10), 25-28. doi: 10.3969/j.issn.1001-2362.2017.10.012 (in Chinese).
- [17] Yin, C. J., Ren, L. Z., & He, R. K. (2008). Discuss on the Creative Product Design Method Based on Concurrent Mode. *Packaging Engineering*, 29 (06), 117-118,199. doi: 10.3969/j.issn.1001-3563.2008.06.065 (in Chinese).

Mode Innovation of the “Belt and Road” Supply Chain Finance under the Background of Digital Technology

(Full Paper)

Yaqin Dou*, Nanjing Institute of Technology, Nanjing, China, douyq@njit.edu.cn

Shaobu Bai, Nanjing Institute of Technology, Nanjing, China, baisb@njit.edu.cn

Li Yao, Nanjing Institute of Technology, Nanjing, China, yaoli@njit.edu.cn

Qian Sun, Nanjing Institute of Technology, Nanjing, China, sunqianbest2020@163.com

ABSTRACT

Supply chain finance (SCF) has the unique advantage of being close to the “Belt and Road” industrial chain. It can meet the investment and financing needs of the “Belt and Road” construction projects, improve the quality and efficiency of the financial services of the “Belt and Road” construction projects, promote the cooperation of the “Belt and Road” industry chain and build a global supply chain production and financing ecology. Comprehensively considering the operating conditions of the “Belt and Road” construction and the impact of digital technology on SCF, the “Belt and Road” SCF model is proposed. In terms of process design and key point layout, an innovative reconstruction of the “Belt and Road” SCF model based on debt asset pledge, movable property pledge and intangible asset pledge is carried out. Further, in view of the problems in the current digital SCF to support SMEs to participate in the construction of the “Belt and Road”, such as inadequate comprehensive supply chain financial services, insufficient coordination of digital technologies, and asymmetric information between banks and enterprises, etc. We propose path design of the trinity of “government promotion, market leadership and social co-governance” of the “Belt and Road” SCF.

Keywords: Supply chain finance, digital technology, Belt and Road

*Corresponding author

INTRODUCTION

In the past 40 years of reform and opening up, SMEs have experienced from small to large, from weak to strong in China. They have made rapid development under the guidance of national policies and supervision, and become an important driving force for economic growth in China. At present, with the downward pressure of domestic economy and weak economic growth, many SMEs have excess capacity and increased inventory. They need to participate in the global value chain through open cooperation and achieve long-term sustainable development in a broad international market. The “Belt and Road” initiative to implement the “going out” strategy of SMEs is not only an attempt to get rid of the insufficient domestic market demand, but also provides new opportunities for them to make full use of global production factors, optimize resource allocation, better product upgrading and enterprise transformation. However, in the face of the huge pressure of international market competition, the lack of capital has become a major bottleneck for SMEs to “go out” development. The low level of domestic financial risk management and control and weak financial synergy effects are the current outstanding issues of financial support for enterprises participating in the “Belt and Road” initiative. Meanwhile, most of the “Belt and Road” initiatives are developing countries with diverse cultural systems, complex political and economic conditions, and huge infrastructure investment needs. Many countries have difficulty in providing necessary financial services to local-invested Chinese companies.

SCF is a financing mode that uses the energy diffusion effect of advantage resources of the core enterprise in the industrial chain to break through the weak credit of many SMEs in the chain, and it is a financing way tailored for SMEs. After Time and Williams-Timme (2000) proposed to pay attention to the financial performance of supply chain management earlier, foreign scholars explored the theory of supply chain finance from the perspectives of applying innovative financial solutions and optimizing supply chain decisions (Wuttke *et al.*, 2013; Kouvelis & Zhao, 2012). Supply chain finance is an innovation in the two fields of supply chain and finance. Therefore, the international representative concept of supply chain finance includes two research perspectives: financial orientation and supply chain orientation. The former focuses on the financial attribute and considers that supply chain finance is a financial scheme provided by financial institutions, which aims to speed up the liquidity of funds in the supply chain (Euro Banking Association, 2014), increase the availability of funds and reduce the cost of funds (Li *et al.*, 2020). The latter emphasizes the collaborative role of supply chain members, extends the boundary of supply chain finance to financial solutions, and also includes supply chain processes and fixed asset financing collaborative solutions (Pfohl & Gomm, 2009). For example, Pfohl and Gomm (2009) define supply chain finance as a process in which two or more organizations including external service providers in the supply chain plan, supervise and control the funds among organizations effectively in order to create value together. The impact of financing channel selection on supply chain performance is one of the key research contents of supply chain finance. Kouvelis and Zhao (2012) studied the capital constrained retailer's preference for financing from banks and suppliers. The results show that in the structurally optimal trade credit contract, the retailer can get a financing interest rate lower than the bank's loan interest rate, and can improve the overall efficiency of the supply chain by increasing the number of orders. Tunca and Zhu (2018) show that buyer intermediary

financing, which transfers the risk from the supplier to the buyer, can significantly improve channel performance and benefit both sides of the supply chain. Domestic scholars based on the financing problems of SMEs, mainly from the perspective of supply chain finance mode innovation (Su & Zhong, 2017), risk governance (Su & Lu, 2015) and economic consequences (Dou & Zhu, 2014).

SCF has developed from the traditional offline SCF stage to the Internet SCF stage in China. With the development of the new generation of information technology, it has begun to enter the digital SCF stage. In recent years, with the advancement of science and technology and the opening of national policies, under the impact of the wave of digital economy, the Internet of Things, blockchain, big data and other technologies continue to develop and apply, and China's SCF has achieved rapid development. Wang (2016) classified the "1+n" mode of supply chain finance dominated by commercial banks, supply chain finance 2.0, and supply chain finance of core enterprises and logistics companies from the perspective of characteristics, sources and evolution paths of supply chain finance participants. The rapid application and development of emerging information and communication technologies, such as artificial intelligence, big data, blockchain, cloud computing, Internet of things, provide a highly innovative development path and means for supply chain operation, and directly lead to the change of management mode in many fields such as supply chain management (Ben-Daya, Hassini, & Bahroun, 2019). Li *et al.* (2020) proposed that the accelerated development of financial technology provides more possibilities and tools for supply chain financial model innovation and risk management. Digital SCF is an in-depth integration of digital technology and industrial ecology and modern finance. It has endowment characteristics such as high-level information sharing, diffuse credit transfer and digital risk control which can realize logistics, information flow, business flow and capital flow. Integration, breaking through the single-loop credit transmission limitations of traditional SCF, realizing the visual management of risks and the efficient operation of capital flows, which can meet the requirements for high-quality financial services for SMEs participating in the construction of the "Belt and Road". Therefore, SCF must become an important financial model for the construction of the "Belt and Road" with its endowment advantages that closely fit the industry chain. This paper intends to innovate the "Belt and Road" supply chain financial service model based on the analysis of the strategic essentials of developing the "Belt and Road" SCF, and to combine the "Belt and Road" SCF service model with the current digital era. The development dilemma faced by finance is building a "Belt and Road" SCF development path.

THE STRATEGIC ESSENCE OF DEVELOPING "BELT AND ROAD" SCF

Digital SCF is the product of traditional SCF embracing digital technology. As shown in figure 1, due to the application of big data, cloud computing, Internet of Things, blockchain and other technologies, digital SCF presents a complex network structure, and the participants in the platform are infinitely expanded. The operation structure of upstream and downstream node enterprises in supply chain is no longer limited to the traditional chain organization, forming an energy coupling cluster network organization. The supporters of supply chain financial activities, such as government, financial institutions and logistics, also reflect the crisscross interest-related relationship, and expand more service channels through platform space. In the complex network system, the platform of SCF plays the role of a neural hub and grasps the coordination of business flow, capital flow, logistics and information flow (hereinafter referred to as "four flows") in supply chain operation. It is familiar with the operation key points of supply chain system, and timely provides various supporting services including finance for the fund deficient enterprises in the platform. Therefore, the enterprises focus on the development of core competitiveness, which is conducive to the improvement of the competitive advantage of supply chain.

Financial cooperation is not only an important part of the construction of the "Belt and Road" initiative, but also an important supporting force for advancing the "Belt and Road" initiative. The related investments along the "Belt and Road" have high-risk and high-yield characteristics. How to turn high-risk and high-return investments along the line into international products, promote the interconnection of funds, and achieve substantial results in financial cooperation along the line is an important issue that all sectors of society should pay attention to. With the support of digital technology, SCF will be accompanied by high-level information sharing, breaking through the bottleneck of traditional SCF in terms of service cost, operational efficiency, risk management and control, and time and space leaps. The innovative development of the "Belt and Road" SCF has the following strategic significance:

Meeting project investment and financing needs

The economic entities in the countries and regions along the "Belt and Road" are mainly private SMEs. Financing difficulties limit the participation of SMEs in the construction of the "Belt and Road" and international development. The inherent shortcomings of SMEs and their weak position in market competition have prevented commercial banks from scientifically and comprehensively assessing overseas investment projects of SMEs, and the phenomenon of "prudent lending" is very serious. At present, driven by the digital economy and financial technology, SCF is undergoing a transition from traditional credit to digital finance. The digitalized "Belt and Road" SCF of "internationalization + digital technology + industrial ecology + modern finance" is deeply integrated, which can provide high-quality financial support for China's SMEs' export-oriented development. SCF is no longer limited to the assessment of the financial situation and asset status of individual SMEs. It is more an overall credit assessment of SMEs from the perspective of the entire industry chain. Many advantageous resources improve the credit system and risk control system of the entire supply chain, and meet the investment and financing needs of SMEs participating in the construction of the "Belt and Road" through the SCF model such as pledge of debt assets, pledge of real estate, and pledge of intangible assets.

Improving the quality and efficiency of financial services

The infrastructure construction projects in countries along the “Belt and Road” have large capital requirements and long construction cycles, which will generate a large amount of accounts receivable and prepaid accounts, resulting in a decrease in the cash turnover rate and the efficiency of the use of funds throughout the supply chain. However, under the influence of the penetration of a new generation of technology, SCF can comprehensively apply the deep mining functions of big data and cloud computing, the intelligent library management and remote positioning functions of the Internet of Things, the encryption and traceability functions of the blockchain, and the automatic risk control and credit functions of artificial intelligence have realized precise services for participating enterprises in the “Belt and Road” initiative, and revitalized accounts receivable and prepaid accounts of SMEs, intangible assets such as and intellectual property rights of science and technology SMEs. In terms of financing time, financing speed and service accuracy, the quality and efficiency of financial services are comprehensively improved to ensure the coordination of production and operation of SMEs and financial services. Under the service of digital SCF, SMEs can quickly obtain financial services at an affordable price, gain business opportunities at a faster rate in the construction of the “Belt and Road”, and seize the international market.

Promoting cooperation in the “Belt and Road” industrial chain

China and the countries along the route have established overseas economic and trade cooperation zones, among the first 19 overseas economic and trade cooperation zones in the country. Four companies including Wuxi Hongdou Group, Guangming Group, Yiduo Investment Development Group and Huatai Investment Real Estate Investment Co., Ltd. have invested in Cambodia’s Westport Special Zone, which has developed into a model project of the National Overseas Economic and Trade Cooperation Park. The Eastern Industrial Park of Ethiopia, jointly invested by Zhangjiagang City Yonggang Group and Qiyuan Group, is an important vanguard of Jiangsu’s layout in Africa. Some countries or regions along the “Belt and Road” have advantages in energy and labor, and are highly complementary to the industrial structure of SMEs inside China. SCF uses its advantages of being close to the industry chain and uses financial service management to bring SMEs closer Industrial chain relationship with countries along the route. In particular, under the integration of digital technologies such as the Internet of Things, big data, and blockchain, the participants in the SCF platform have been infinitely expanded, and more upstream and downstream node companies in the supply chain of countries along the route have participated in the construction of the "Belt and Road", sharing information such as capital flow, logistics, business flow and information flow in the supply chain operation will greatly promote the economic exchanges and close cooperation between SMEs inside China and enterprises in countries along the route.

Building a global supply chain production and financing ecology

While participating in the construction of the “Belt and Road”, SMEs apply SCF to the real economy, at the same time prevent and control financial risks, promote the overall supply chain to go out, and promote the development of domestic and foreign industries, achieve cooperation between domestic and foreign enterprises and build a global supply chain production and financing ecology on the basis of promoting the upgrading of the real economy. With supply chain innovation and application under digital technology, SCF will accelerate industrial integration, promote SMEs and industries along the “Belt and Road” to actively participate in the global division of labor and cooperation, and provide services for the “Belt and Road” smooth trade, facilities connectivity, and financial finance to create conditions for the smooth service of the “Belt and Road” trade, connectivity of facilities, and financing. As the "Belt and Road" initiative develops in depth, digital SCF will continue to dig deeper into the industry, use various digital technologies to obtain information, prevent financial risks, provide credit services for enterprises, and ease the financing difficulties for SMEs participating in the construction of the “Belt and Road” to promote the organic integration of global industrial innovation and financial innovation.

MODEL INNOVATION THE “BELT AND ROAD” SCF UNDER THE BACKGROUND OF DIGITAL TECHNOLOGY

The model innovative of the “Belt and Road” SCF can better provide project investment and financing services for participating enterprises in the construction of the Belt and Road in China, promote global industry chain cooperation, and build a global supply chain production and financing ecology. In this section, considering the convergence of digital technologies such as the Internet of Things, blockchain, big data and cloud computing, we will innovate and reconstruct the “Belt and Road” SCF model based on debt pledge, movable property pledge and intangible asset pledge from process design and key control points to promote digital SCF services to SMEs participating in the Belt and Road Initiative.

The “Belt and Road” SCF Model Based on Credit Pledge

The “Belt and Road” SCF based on the pledge of credit is a financial service for SMEs participating in the construction of the “Belt and Road” to apply for loans from the SCF platform using the debt assets such as accounts receivable or prepaid accounts as collateral. mode. Its operation design is shown in Figure 1.

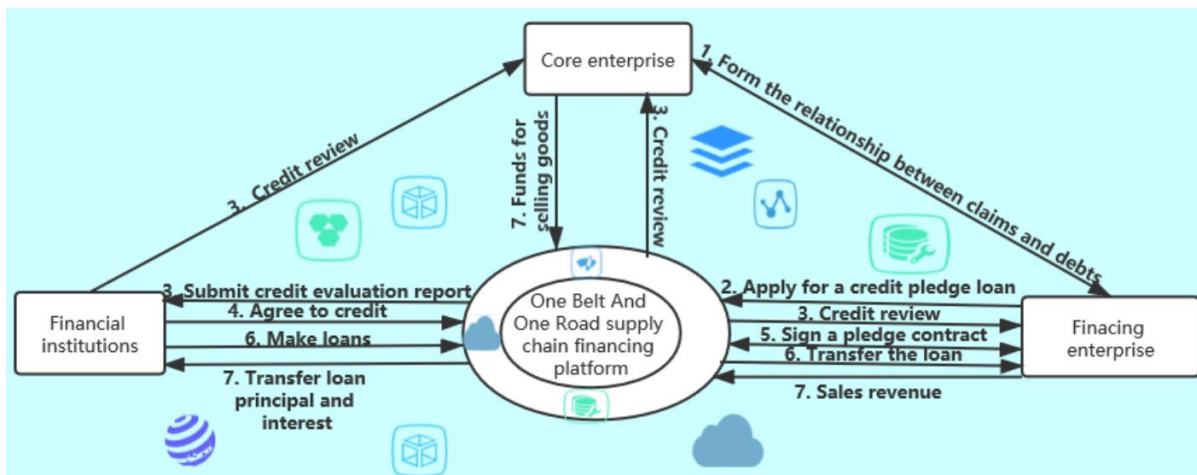

Figure 1: Process of the “Belt and Road” SCF mode based on credit pledge

The main process is as follows:

- ① SMEs participating in the construction of the “Belt and Road” act as financiers to form debt and debt relationships with core enterprises;
- ② Financing companies apply for loans from the platform by virtue of pledge of creditor's rights;
- ③ Based on digital technologies such as big data and blockchain, the platform inspects business transactions and operating conditions between financing companies and core companies, evaluates the solvency and credit rating of financing companies, generates credit evaluation reports, and submits them to financial institutions ;
- ④ Financial institutions combined with the online credit report of financing companies provided by the platform and related credit records from logistics or other departments for comprehensive evaluation, and combined with the Internet of Things, blockchain, cloud computing and other technologies to confirm the creditor's rights and estimate the value of them and make credit decisions accordingly;
- ⑤ Based on the credit decision-making report made by the financial institution, the platform signs the credit pledge loan contract with the financing enterprise and feeds back it to the financial institution;
- ⑥ According to the pledge loan contract, the financial institution transfers the funds to the platform capital settlement center and transfers it to the financing enterprise.
- ⑦ Supply chain enterprises allocate the sales revenue as a source of repayment to the platform payment settlement center to repay the principal and interest to financial institutions.

The key to the effective operation of the “Belt and Road” SCF model based on the pledge of credit rights lies in three points. One is the authenticity of the credit and debt relationship between the upstream and downstream enterprises in the supply chain participating in the construction of the “Belt and Road”; the second is the quality of the pledged debt assets themselves; the third is the self-repayment of the future sales revenue of supply chain enterprises. "Belt and Road" SCF must achieve the risk control of the above three key points with the support of digital technology. First of all, big data technology can capture every transaction scenario of upstream and downstream enterprises in the supply chain, ensuring the authenticity of the relationship between claims and debts based on real trade activities between enterprises, and the distributed bookkeeping technology of the blockchain can also guarantee the claims authenticity, and the receivable claims or prepaid confirmed equity can be split and circulated among platform companies, which will not only expand the credit enhancement of platform companies, but also provide more guarantee for the authenticity of debt assets. Secondly, the quality of the debt assets mainly depends on the debtor’s operating status and credit level. Under the synergy of big data and cloud computing technologies, the platform can quickly obtain the debtor’s transaction status from the huge database, and draw the image of the debtor, clarify the overall status of the debtor through various association and coupling relationships, quickly evaluate the value of the debt asset, and provide information for the financial institution to make credit lines and interest rate levels. Finally, the use of intelligent contracts to complete online automatic approval and allocation of funds, and based on the system closed self-compensation system to achieve supply chain enterprises sales revenue back to financial institutions.

The “Belt and Road” SCF Model Based on Pledge of Movable Property

In the “Belt and Road” SCF operation based on movable property pledge, financing companies apply physical current assets, such as raw materials, inventory commodities, etc., as pledges to financial institutions to apply for loans. Based on the results of the platform's use of various digital technologies to implement dynamic monitoring and value estimation of the movable property pledges owned by the enterprise, financial institutions make credit decisions. Financing companies use the inflow of funds from future sales as a source of repayment. Its operation design is shown in Figure 2.

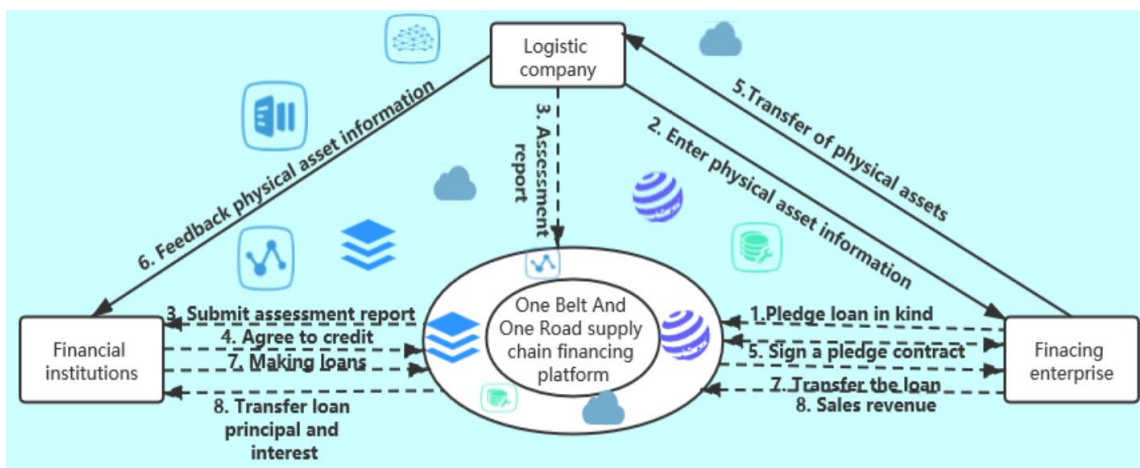

Figure 2: Process of the “Belt and Road” SCF mode based on physical charge

The main process is as follows:

- ① Financing enterprises participating in the construction of the “Belt and Road” submit financing applications to the platform by virtue of their own movable property;
- ② With the help of big data, Internet of Things and other technologies, the platform will record the movable property information used by the financing companies to pledge into the supply chain financial system through the standardized interface between the platform and third-party logistics companies;
- ③ The platform uses a variety of digital technologies such as the Internet of Things and cloud computing to accurately locate the quantity and quality of physical assets such as raw materials and inventory commodities, and makes real-time value evaluation of movable property according to market dynamics, and provides evaluation certificates to financial institutions;
- ④ The financial institution makes a comprehensive evaluation of the credit status of the financing enterprise in combination with the information feedback of other credit reference systems, and makes credit decision accordingly;
- ⑤ The platform signs a movable property pledge loan contract with a financing enterprise, and feeds back it to the financial institution;
- ⑥ The third-party logistics checks and accepts the movable property pledge, and applies the Internet of Things, cloud computing and other technologies to perform dynamic monitoring and real-time evaluation of the movable property status throughout the process, providing real-time data for financial institutions to lend;
- ⑦ The financial institution allocates funds to the financing enterprise through the platform payment settlement center based on the comprehensive information provided by the platform and the movable property pledge loan contract.
- ⑧ The financing enterprise allocates the inventory sales revenue as the source of repayment to the platform payment settlement center, and repays the principal and interest to the financial institution.

Based on the “Belt and Road” SCF model of movable property pledge, the key controls to be done include the monitoring and value evaluation of movable property, the effectiveness of movable property pledges and the repayment of future sales revenue. Under the influence of digital technology, “Belt and Road” SCF can realize visual management from the aspects of warehousing and logistics, and improve the flexibility of SCF intelligent services. The Internet of things is conducive to access to the underlying business information, broaden the information collection channels, and can be used for inventory pledge financing mode (Wang, Yu, & Wang, 2019). With the support of the huge Internet of Things system, the “Belt and Road” SCF platform can visually manage the real estate pledges of financing companies in real time and accurately through real-time warehousing management. The platform can quickly make value assessments based on market demand, which can convert offline objects into online data, to solve the problem of difficult and expensive evaluation of the value of cross-regional and cross-border movable property pledges for Chinese SMEs and companies from other countries along the Belt and Road. Meanwhile, based on the real transaction information, the platform can use the formed big data, Internet of Things and other technologies to confirm the ownership of movable property, and through the Internet of Things video monitoring and frequency radio technology to complete the alarm and 24-hour monitoring of the inventory location transfer, lack of quantity and quality damage to ensure the effectiveness of the movable property pledge. Finally, through the intelligent collection system, to ensure that the financing enterprise's movable property sales income will automatically repay debts and complete the recovery of funds.

The “Belt and Road” SCF Model Based on Pledge of Intangible Assets

The core concept of the operation of the digital SCF model based on the intangible asset pledge is that the financing enterprise relies on the pledge of the future income rights of the intangible assets from the transferee company to obtain loans from financial institutions. This model is mainly suitable for innovative SMEs participating in the construction of the “Belt and Road”. Such enterprises have a large number of intangible assets such as patents and proprietary technologies. They have the characteristics of “light capital and heavy technology”. The operation of the model requires the platform to set up a certain

introduction mechanism, introducing government departments such as intellectual property trading centers and intangible asset evaluation institutions. Its operation design is shown in Figure 3.

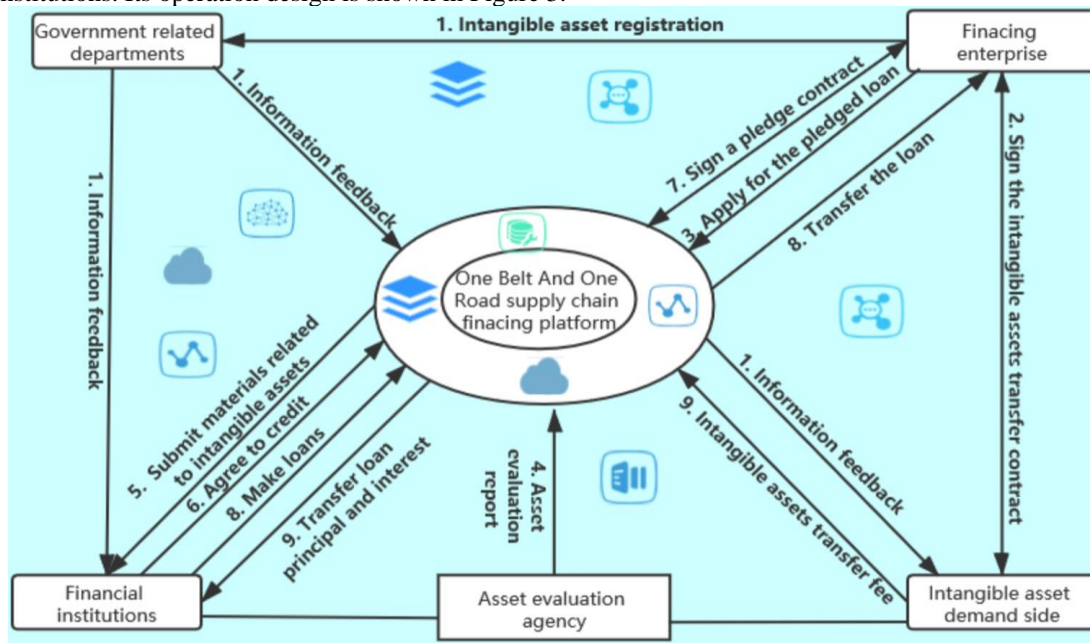

Figure 3: Process of the “Belt and Road” SCF mode based on intangible asset pledge

The main process is as follows:

- ① The financing enterprise registers the intangible assets to be transferred for use right in the intellectual property trading center, which releases information through the “Belt and Road” supply chain financial platform and feeds it back to the technology demand side;
- ② The technology demander and the financing company agree on the rights and obligations of both parties and the transfer fee for the right to use, and sign an intangible asset transfer contract;
- ③ The financing enterprise makes a financing application to the platform by virtue of the future income right formed by the transfer of intangible assets;
- ④ The platform entrusts an asset evaluation institution with corresponding qualifications to conduct a comprehensive evaluation of the intangible assets' ownership, application prospects, future income and other related matters, and obtain an asset evaluation report;
- ⑤ The platform submits the documents related to the transfer of intangible assets, including the transfer contract of the two parties of the intangible asset transaction, the value assessment report of the intangible asset income right, etc., to the financial institution;
- ⑥ Based on the evaluation results submitted by the platform and the contract signed by both parties of technology supply and demand, the financial institution will conduct a comprehensive evaluation of the credit status of the financing enterprise and make a credit decision based on the transaction information obtained by the platform's big data;
- ⑦ Based on the credit decision report sent by the financial institution, the platform signs an intangible asset pledge loan contract with the financing enterprise and feeds it back to the financial institution.
- ⑧ Financial institutions allocate loans to financing enterprises through the platform payment settlement center according to the intangible asset pledge loan contract;
- ⑨ The technology demander will repay the financing enterprise loan to the financial institution through the platform settlement center according to the amount agreed in the contract.

This mode combines intangible asset pledge loans and SCF organically, using SCF's intangible asset use rights to transfer income and self-paying repayment to solve the problem of insufficient guarantee of intangible asset pledge loans and reduce the risk of financial institution loans. During the operation of the model, the key control points for financial institutions to make credit decisions include the pledge of future income rights of intangible assets and repayment of transfer fees for use rights of intangible assets. First of all, with the support of the “Belt and Road” SCF platform, the intangible asset appraisal agency based on the big data deposited by the platform to realize the confirmation of intangible assets and ensure that the ownership of intangible assets is not disputed. Secondly, the newly-increased profit created by the transferee using the intangible assets transferred by the financing party is an important source for the financing enterprise to charge the intangible asset usage fee, and also an important guarantee for the financial institution to obtain the return of funds. This requires the intangible asset appraisal agency to be able to use a variety of digital technologies to integrate and scientifically and reasonably assess the recipient's operating conditions and the future benefits and risks of using the intangible assets, accurately estimate the transfer value of the intangible asset use rights, and make credit lines and interest rate decisions for financial institutions to provide a reliable basis. Finally, the self-compensation fund return system of the SCF ensures that the transferee will repay the bank the intangible asset transfer fee that the financing enterprise should charge through the platform settlement center.

THE DILEMMA FACING THE “BELT AND ROAD” SCF UNDER THE BACKGROUND OF DIGITAL TECHNOLOGY

At this stage, the development of China's “Belt and Road” SCF has just started, the application of digital technology is not yet mature, and the infrastructure construction is insufficient. In practice, it is also faced with many restrictions in law, supervision and products, which restricts the quality and efficiency of the SCF to the enterprises participating in the “Belt and Road” initiative.

Insufficient comprehensive management services

During the construction of the “Belt and Road”, developing countries along the Belt and Road are the majority, and there are differences in trade policies, resulting in poor circulation of goods and investment channels in cooperation between SMEs and enterprises along the Belt and Road. Commercial banks have long been engaged in financial work and have advantages in financial services and risk management. However, they have shortcomings in controlling supply chain business links, developing supply chain customer groups, and information technology applications; The core enterprises in the supply chain have natural advantages and conditions in controlling the supply chain business processes, and their disadvantages are financial resources and risk control management. During the construction of the “Belt and Road”, SMEs lacked the support of a powerful information service platform integrating finance, logistics, credit and other services, which affected the collection and risk assessment of investment and financing information of countries along the “Belt and Road”. In turn, it affects the investment and financing decisions of SMEs participating in the “Belt and Road” construction. If the superior resources in the SCF ecology can be gathered into the SCF platform through alliances and integrated with the support of digital technology to promote the comprehensive management capabilities of the SCF. As a result, the quality and efficiency of “Belt and Road” supply chain financial services will be improved to a greater extent.

Insufficient collaborative application of digital technology

With the rapid development of digital economy and the proposition of the "new infrastructure" strategy in China, SCF is inseparable from the integration and support of digital technologies such as the Internet of Things, blockchain, big data, and cloud computing. In recent years, with the development of big data technology and the promotion of modern logistics, e-commerce and other industries, business volume of the domestic SCF has increased rapidly year by year. However, the new generation of technologies such as blockchain, artificial intelligence, cloud computing, and the Internet of Things have high application difficulty factors, especially the integration of multiple technologies is more difficult. At present, the participants in the construction of the “Belt and Road” are still unable to fully apply various emerging technologies to all modules of the SCF platform. At the same time, the application costs of emerging technologies are high, requiring high labor costs and infrastructure construction costs. The participants in the “Belt and Road” SCF are also unable to bear the technical costs required for the full development of SCF. Core modular service, good interface and highly complementary resources are three important components of digital platform (Spannoletti, Resca, & Lee, 2015). However, many countries and regions are involved along the “Belt and Road”, and the level of financial technology and information technology in various countries or regions varies. There are deviations in the technical application standards of different participants, the data exchange standards are not uniform, and the interface standards between various service ports vary greatly. These will also affect the service quality and effectiveness of the “Belt and Road” SCF.

Asymmetric information between banks and enterprises increasing risks

At present, during the construction of the “Belt and Road”, many core enterprises in energy, infrastructure, manufacturing and other key industries have established cooperative relations with commercial banks, but different countries or cross-border regions have increased Information asymmetry between commercial banks and downstream enterprises of the supply chain in key industries. As a result, it is impossible to accurately grasp the financial status, operation management and other information of domestic SMEs and foreign supply chain upstream and downstream enterprises cooperating along the Belt and Road. This will also lead to the inability to effectively interconnect information flow, capital flow and logistics, increase the credit risk faced by financing, and limit the application scope of digital SCF in the construction of the “Belt and Road”. SMEs and core enterprises along the “Belt and Road” initiative usually cooperate. These will make it more difficult for the domestic SCF business model to be more mature to be promoted and applied in the construction of the “Belt and Road”.

Insufficient infrastructure investment

SCF to support the construction of the “Belt and Road” will inevitably require the deployment of financial institution outlets in the countries along the route. However, factors such as policies, market conditions and enterprise levels in different countries and regions have limited the speed of the overseas outlets of Chinese banks. At the same time, there is insufficient investment in financial infrastructure such as the offshore RMB market and payment settlement system along the “Belt and Road”. Multinational companies face barriers to overseas capital operation and foreign investment exchange, foreign banks participating in the domestic inter-bank bond market, as well as overseas development of Chinese-funded enterprises. These problems have restricted the opportunities for domestic banks to "go global" and the quality of service provided by the SCF to the construction of the "Belt and Road". Driven by the digital economy, new generation of informatization technology has developed rapidly in China. Industries such as e-commerce and modern logistics are in a leading position in countries around the world. Convenient mobile Internet has also provided a solid technology and scenario foundation for the development of industrial chain finance. However, these infrastructures that support the development of SCF have lagged behind in the

developing countries along the “Belt and Road”, which has affected the scope of SCF’s overseas promotion and the space for further upgrades.

PATH OF INNOVATION DEVELOPMENT OF “BELT AND ROAD” SCF UNDER THE BACKGROUND OF DIGITAL TECHNOLOGY

At present, digital SCF is in its infancy in China, and there are still many problems in supporting SMEs to participate in the construction of the “Belt and Road” initiative. To promote the high-quality services of digital SCF for SMEs participating in the construction of the “Belt and Road”, in view of the current difficulties in the application of digital SCF, we propose to formulate reasonable strategies from three aspects: top-level government design, market-leading level and social co-governance in this section.

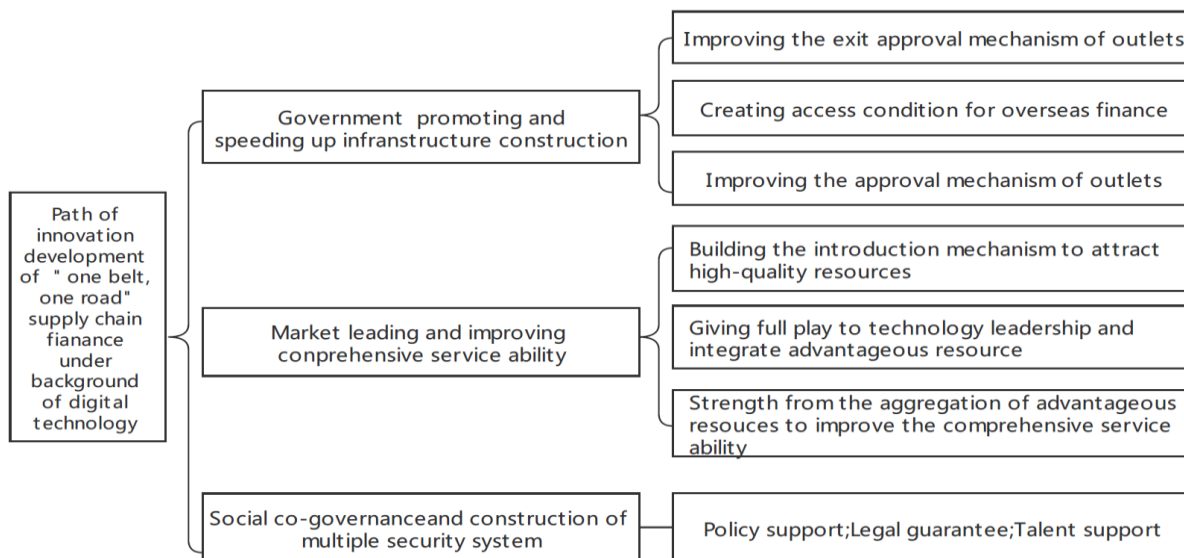

Figure 4: The path of innovation development of the “Belt and Road” SCF

The government promoting and speeding up the infrastructure construction

In order to realize the high-quality services provided by SCF to enterprises participating in the “Belt and Road” construction, the government should increase investment and accelerate the infrastructure construction of SCF. First, improving the exit approval mechanism of outlets. Regulators should build an approval mechanism for establishing overseas branches of commercial banks, securities institutions, insurance companies, etc. In accordance with the internal requirements and external environment of the “Belt and Road” SCF operation, a financial exit approval system suitable for the “Belt and Road” development strategy was formulated to guide and regulate the establishment of domestic financial institutions in countries and regions along the “Belt and Road”. Second, create access conditions for overseas finance. It is necessary to strengthen communication with the governments and regulatory authorities of countries along the “Belt and Road”, create a friendly financial “access” environment, and promote the distribution of outlets along the “Belt and Road” by various domestic financial institutions. It is necessary to encourage domestic banks to cooperate with overseas banks to develop local currency accounts, currency exchange points, and mutual agency banks to create various conditions for the development of “Belt and Road” SCF services. Third, give full play to the synergy effect of SCF service ports. It is necessary to integrate and apply a variety of digital technologies between overseas domestic banks, build a high-level information sharing platform, and form synergies in various service ports such as investment project selection, corporate credit enhancement, and financial risk control to jointly promote the "Belt and Road" Innovative development of SCF.

Market leading and improving comprehensive service ability

The development of the “Belt and Road” requires more intelligent, accurate and low-risk financial services. To meet the needs and goals of market development, a strong supply chain financial information platform should be built with the support of digital technology to achieve the promotion of comprehensive supply chain financial service capabilities. First, build an introduction mechanism to attract quality resources. Under the market leadership, a reasonable access mechanism is set up to gather institutions with superior resources in the area of customer acquisition, capital, credit and risk control into the supply chain financial platform to enrich high-quality port resources to improve the comprehensive service capacity of the SCF. Second, give full play to technological leadership and integrate superior resources. Under the synergy of digital technology, improve the cross-border integration of high-quality resources with financial, insurance, logistics and other institutions, and improve the corresponding supporting facilities, promote the comprehensive efficiency of the advantageous resources in various fields and the in-depth development of cross-border integration as well. Thirdly, aggregate the advantageous resources to improve the comprehensive service capabilities. Through digital technology to integrate various industries, various system departments, and various enterprise channels, and promote high-quality participation of all parties in the supply chain for in-depth and extensive cooperation. Use ICT technology to empower the supply chain, build a diversified service architecture, integrate internal services with external company service function modules, achieve high compatibility, high integration

configuration, high availability, enhance the credit of SMEs. Reduce the risk of financial loans, give full play to the scale benefits of SCF, and provide high-quality financial services to more small, medium and micro enterprises participating in the construction of the “Belt and Road” initiative.

Social governance to build multiple guarantee systems

The “Belt and Road” SCF needs to build a guarantee system from various aspects such as policies, resources, and regulatory guarantees, and promote the quality and efficiency of the “Belt and Road” SCF through social co-governance. First, policy support. Policy support is one of the major engines for the innovative development of supply chain financial models (Dou, & Zheng, 2019). In recent years, the Ministry of Industry and Information Technology, the China Banking and Insurance Regulatory Commission, the Central Bank, and the National Development and Reform Commission have issued more than 10 guidance policies about SCF. Local governments at all levels have responded actively, issued incentive policies, and provided target guidance. These have become the driving forces for the development of SCF. Second, legal protection. The “Belt and Road” SCF is still in the initial development stage, and there is a large room for adjustment in the formulation of relevant laws and regulations. The cross-border participants of SCF put forward higher requirements on the coverage of laws and regulations. Therefore, it is necessary to improve the laws and regulations system from the top-level design, and to continue to follow up the laws and regulations by the relevant departments; not only to improve and standardize the third-party depository system of funds, to control financial risks, but also to improve the collateral monitoring regulations, to control the risk of collateral. At the same time, the government and industry regulators need to introduce sound business management methods to ensure the legitimacy of the platform’s service providers. In the context of digitization, we must also pay attention to improving data privacy protection, and make more detailed and reasonable requirements on the legality and compliance regulations of data use, protect the privacy of all parties and the legality of electronic contracts, and provide a good legal environment for development of the “Belt and Road” SCF. Third, talent support. The innovation and development of “Belt and Road” SCF is inseparable from the support of professionals. Therefore, focusing on training compound talents who are also proficient in international business, information technology, supply chain management and finance is an urgent problem that needs to be solved.

CONCLUSION AND INSPIRATION

We first analyze the strategic significance of development of the “Belt and Road” SCF. Then, considering the impact of digital technology, the model of the “Belt and Road” SCF based on credit pledges, movable property pledges and intangible asset pledges has been innovatively reconstructed from the perspective of process design and key control points. Further, we discuss the development dilemma faced by the “Belt and Road” SCF under the current digital technology background, and design innovation development path of the “Belt and Road” SCF from the perspectives of top-level government design, market-led level and social co-governance. We propose the development of the “Belt and Road” SCF can meet the investment and financing needs of “Belt and Road” construction projects, can improve the quality and efficiency of “Belt and Road” construction projects, and can promote the cooperation of the “Belt and Road” industry chain and the establishment of a global Supply chain production and financing ecology. We think the key control points for the effective operation of the “Belt and Road” SCF model based on the pledge of claims include: the authenticity of the debt and debt relationship between upstream and downstream enterprises in the supply chain participating in the construction of the “Belt and Road”, and the quality of the pledged debt assets themselves and self-repayment of supply chain companies’ future sales revenue. The operation of the “Belt and Road” SCF model based on movable property pledge should be paid attention to the three aspects of controlling the movable property monitoring and value evaluation, the effectiveness of movable property pledges and the repayment of future sales revenue. The operation of the “Belt and Road” SCF model based on the intangible asset pledge must strengthen the control of the intangible asset's future income right pledge and intangible asset use right transfer fee repayment. At present, the development of the “Belt and Road” SCF may face the problems of insufficient comprehensive service capabilities, insufficient application of digital technology, asymmetry of bank and enterprise information, and insufficient infrastructure investment. We propose realization path of the “Belt and Road” SCF of the trinity of “government promotion, market leadership, and social co-governance” in this paper.

ACKNOWLEDGMENT

This work was financially supported by major projects of innovation fund of Nanjing Institute of Technology 2020: Research on innovation and promotion path of credit agglomeration mode of Jiangsu agricultural supply chain finance under the background of new infrastructure construction (CKJA202004), China; finance development special fund project of applied research fine engineering of social sciences of Jiangsu province 2019: Research on the realization path of "going out" of private enterprises in Jiangsu province with digital supply chain finance precision service under the strategy of "one belt and one way" (19SCB-015), China.

REFERENCES

- [1] Ben-Daya, M., Hassini, E., & Bahroun, Z. (2019). Internet of things and supply chain management: a literature review. *International Journal of Production Research*, 57(15-16), 4719-4742. doi: 10.1080/00207543.2017.1402140
- [2] Dou Y.Q. & Zhu J.F (2014). Coordination strategy of financial services and operations management in supply chain of capital-constrained retailer. *Control and Decision*, 29(11): 2018-2026. doi: 10.13195/j.kzyjc.2013.1139
- [3] Dou Y.Q. & Zheng M.X. (2019). Research on Theoretical Framework, Conditional Constraints and Governance Strategies of B2B supply chain finance. *Journal of Nanjing Institute of Technology (Social Science Edition)*, 19(02), 46-51. doi: 10.13960/j.issn.2096-238 X.2019.02.009

- [4] Euro Banking Association. Supply chain finance EBA European market guide.2014.
- [5] Kouvelis, P. & Zhao, W. (2012). Financing the newsvendor: supplier vs. bank, and the structure of optimal trade credit contracts. *Operations Research*, 60(3), 566-580. doi:10.1287/opre.1120.1040
- [6] Li, J., Wang, Y.J, Fang, G.Z., Wang, S.Y. & Song, Y.G. (2020). Supply chain finance review: Current situation and future trend. *System Engineering---Theory & Practice*, 40(8): 1977-1995. doi: 10.12011/1000-6788-2019-2801-19
- [7] Pfohl, H.C. & Gomm, M. (2009). Supply chain finance Optimizing financial flows in supply chains. *Logistics Research*, 1(34): 149-161. doi: org/10.1007/s12159-009-0020-y
- [8] Spagnoletti, P., Resca, A., & Lee, G. (2015). A design theory for digital platforms supporting online communities: a multiple case study. *Journal of Information technology*, 30(4), 364-380. doi: 10.1057/jit.2014.37
- [9] Su Y.L., & Zhong B.Y. (2017). Supply chain finance decision analysis with a partial credit guarantee contract. *Journal of Applied Mathematics and Physics*, 5(6), 1355-1369. doi: 10.4236/jamp.2017.56112
- [10] Su Y.L. , & Lu N. (2015). Supply chain finance credit risk evaluation method based on self-adaption weight. *Journal of Computer and Communications*, 3(7), 13-21. doi: 10.4236/jcc.2015.37002
- [11] Timme S.G., Wiliams-Timme C. (2000). The financial-SCM connection. *Supply Chain Management Review*, 4(2): 33-40.
- [12] Tunca, T. & Zhu, W. (2018). Buyer intermediation in supplier finance. *Management Science*, 64(12), 5631-5650. doi: 10.1287/mnsc.2017.2863
- [13] Wang, M. (2016). Research on the evolution of supply chain finance mode in the “internet+” era. *Open Journal of Social Sciences*, 4(3), 130-136. doi: 10.4236/jss.2016.43019
- [14] Wang, R., Yu, C. & Wang, J. (2019). Construction of supply chain financial risk management mode based on Internet of Things. *IEEE Access*, 7, 110323-110332. doi: 10.1109/ACCESS.2019.2932475
- [15] Wuttke, D. A., Blome, C., Foerstl, K., & Henke, M. (2013). Managing the innovation adoption of supply chain finance—Empirical evidence from six European case studies. *Journal of Business Logistics*, 34(2), 148-166. doi: 10.1111/jbl.12016

Opportunity in Pandemic: Understand how Customers Look at your Banner Ads

(Full Paper)

Janjao Mongkolnavin*, Chulalongkorn University, Thailand, janjao@cbs.chula.ac.th
Pimmanee Rattanawicha, Chulalongkorn University, Thailand, pimmanee@cbs.chula.ac.th
Sawitree Boonpatcharanon, Chulalongkorn University, Thailand, sawitree@cbs.chula.ac.th
Chaiyasut Jongtavornvitaya, Chulalongkorn University, Thailand, chaiyasut@cbs.chula.ac.th

ABSTRACT

The importance of e-business is constantly increasing and it becomes even more essential during the time of COVID-19 outbreak. Although internet vendors are less affected by the pandemic than others, they all have to be careful with their spending during this delicate time. Effective spending on digital marketing undoubtedly can increase customers and profits of the business. The objective of this study is to examine how people look at banner ads displayed on a web page in four different positions (top, bottom, left, and right). The study used an eye-tracking tool, Mirametrix S2 Eye Tracker, to collect eye gaze data from 320 volunteer participants. The collected data were used to calculate (1) banner ads' time to first fixation, (2) banner ads' first fixation duration, (3) banner ads' total fixation duration, and (4) banner ads' fixation count of each participant. Statistical analyses on the data indicate that the banner ads' positions have a significant impact on banner ads' time to first fixation. This result can be beneficial to internet vendors in deciding on where to place banner ads to attract the most attention from their potential customers.

Keywords: Banner ads, time to first fixation, first fixation duration, total fixation duration, fixation count.

*Corresponding author

INTRODUCTION

Albert Einstein said, "In the middle of a difficulty lies opportunity". This statement has never been so true for e-businesses especially during the time of COVID-19 pandemic. According to the report by Adobe, COVID-19 has massively accelerated the growth of e-commerce (Koetsier, 2020). Retail e-commerce sales worldwide grew from US\$3,535 billion in 2019 to US\$4,206 billion in 2020 (Statista.com, 2020).

Currently, businesses focus deeply on using digital advertising to reach their target groups or their potential customers. According to Statista.com, the global banner advertising market size is about US\$52.8 billion in 2020 and will reach US\$71.6 billion in 2024 (Lindlahr, 2020). However, because of the COVID-19 outbreak, businesses worldwide are more cautious in their spending. Their advertising spending in 2019 was revised from US\$662.99 billion to US\$646.71 billion, and in 2020, it was revised from US\$712.02 billion to US\$691.72 billion (Statista.com, 2020). To effectively utilize business spending on digital advertising, especially on banner advertising, businesses need to understand how potential customers look at banner ads.

LITERATURE REVIEW

Position of Banner Ads

Banner advertising or banner ad is one of the most common forms of digital advertising. There are previous studies concerning banner ad positions. Heinz and Mekler (2012) found that banner ads at the top and bottom positions did not have an impact on viewers' recognition. Ryu *et al.* (2007) indicated that a banner ad that was placed at the right position on a web page would be evaluated more positively than a banner ad that was placed at the left position on a web page. John and Sathiyaseelan (2014) studied four positions of banner ads and suggested that, in terms of explicit memory, the top and right positions were the most and the least effective positions, respectively.

Eye Tracking

In e-commerce studies, there are many ways to measure customer interest, or to be more specific, customers' interest in banner ads, including the use of an eye-tracking device (Hervet *et al.*, 2011; Saowwapak-adisak, Mongkolnavin, & Rattanawicha, 2015; Tangmanee, 2016). It is expected that when customers notice a banner ad, if they are interested in the advertised products or services, they would spend time looking at the banner ad and eventually click on it to obtain additional information. Lee and Ahn (2012) indicate that static banner ads are more effective than animated ones. Animation in banner ads attracts less attention and reduces the positive effect of attention on memory. Porta, Ravarelli, and Spaghi (2013) find that congruity between web content

and banner ads subject makes a difference to the way banner ads are looked at and emphasize that the design of banner ads for web content is very important.

In this study, we are investigating how viewers look at the banner ads that are placed at different positions on a web page in terms of time to first fixation (the amount of time it takes viewers to look at the banner ad for the very first time), first fixation duration (how long their first look at the banner ad lasts), total fixation duration (the total amount of time they look at the banner ad), and fixation count (the number of times they look at the banner ad).

RESEARCH QUESTION

This research aims to study four positions of banner ads on a web page: top, bottom, left, and right. The main research question is whether four different positions of banner ads on a web page have different impacts on how potential customers look at the banner ads in terms of (1) time to first fixation, (2) first fixation duration, (3) total fixation duration, and (4) fixation count.

Research Hypothesis

In order to answer the research question, four hypotheses listed below are tested.

H1: Banner ad positions in a web page impact banner ads' time to first fixation

H2: Banner ad positions in a web page impact banner ads' first fixation duration

H3: Banner ad positions in a web page impact banner ads' total fixation duration

H4: Banner ad positions in a web page impact banner ads' fixation count

RESEARCH METHODOLOGY

Research Tools

The research tools used in our empirical study were the same ones used in our previous work (Saowwapak-adisak, Mongkolnavin, & Rattanawicha, 2015). Four experiment web pages with one inserted banner ad on each page, together with an eye-tracking device were employed to collect participants' eye gaze. A questionnaire was used to collect additional data. Details of each research tool are given as follows.

Static banner ads

Static or non-animated banner ads were employed in the study. To ensure that the total area (in pixels) of each banner ad is approximately equal, each banner is designed to consist of six small parts as shown in Figure 1 and Figure 2. Each of these small parts has a size of 160 x 100 pixels. The first part is the advertising company logo. The second, fourth, and sixth parts present advertising text. Advertising pictures are displayed in the third and the fifth part of the banner. Two styles of banner ads were used in the study. The vertical style (as shown in Figure 1) is for display at the left and right position, while the horizontal style (as shown in Figure 2) is for display at the top and bottom positions. The vertical banner ad has a total size of 160 x 600 (or 96,000 pixels), which is the size of a Skyscraper banner ad (Myers, 2020). The horizontal banner has a total size of 960 x 100 (also 96,000 pixels), which is closest to 970 x 90, the size of a Large Leaderboard banner ad (Myers, 2020).

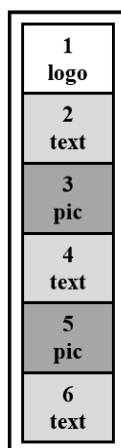

Source: This study.

Figure 1: Vertical style banner ad.

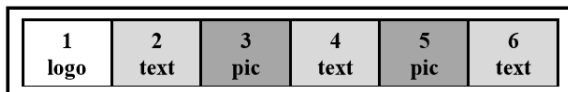

Source: This study.
Figure 2: Horizontal style banner ad.

Web pages

A restaurant review web page was used in the empirical study. The web page is designed to compose of two main areas to display the web content and the banner ad, respectively. Four web pages that display the banner ads in different areas are shown in Figure 3 to Figure 6.

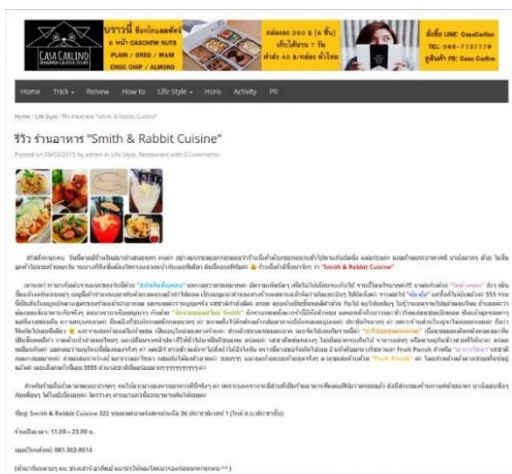

Source: This study.
Figure 3: Web page with the banner ad at the top position.

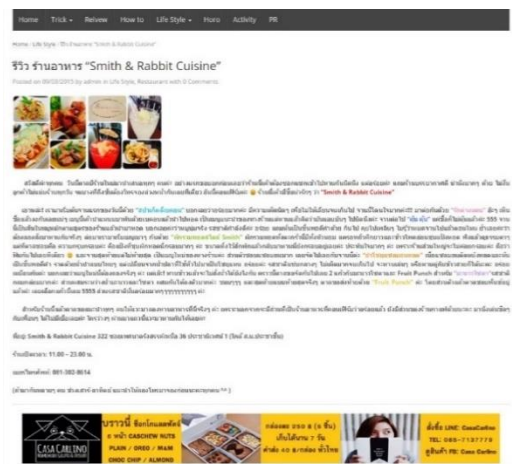

Source: This study.
Figure 4: Web page with the banner ad at the bottom position.

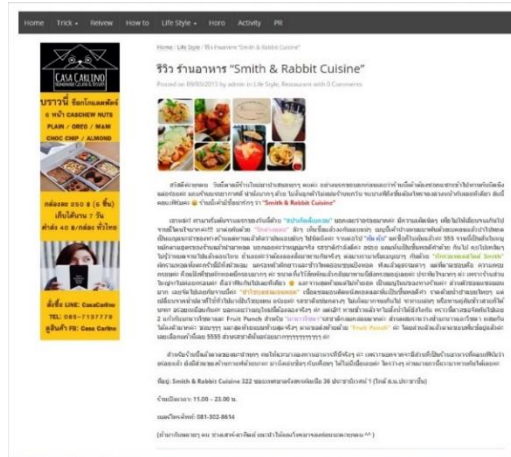

Source: This study.
Figure 5: Web page with the banner ad at the left position.



Source: This study.
Figure 6: Web page with the banner ad at the right position.

Eye-tracking device

The Miramatrix S2 Eye Tracker in Figure 7, is an eye-tracking device that is used to detect and collect the eye gaze of each participant during the experiment, as shown in Figure 8. The Miramatrix S2 Eye Tracker has a hardware part, which tracks the participant's eye movements and collects eye-gaze data. A software part, the eye-tracking viewer, is used to interface with the device. The software saves eye-gaze data as a CSV document. These collected eye-gaze data were later used to calculate (1) time to first fixation, (2) first fixation duration, (3) total fixation duration, and (4) fixation count for the study.



Source: <http://imotions.com/hardware/miramatrix-s2/>.
Figure 7: Miramatrix S2 Eye Tracker.

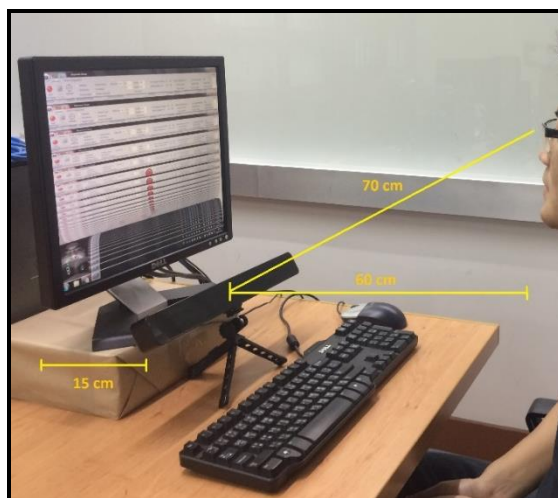

Source: This study.

Figure 8: Eye tracking experiment setup with Mirametrix S2 Eye-Tracker.

Questionnaire

A questionnaire was used to collect demographic data of each participant and his/her answers to questions about restaurant review, the assigned task. The collected demographic data include gender, age, education, handedness, Internet usage experience, and interest in banner ads in general. The restaurant review questions concern, for example, restaurant name, menu, name of the reviewer, and interest in restaurants.

Research Procedure

The research background and objectives were explained to students at Chulalongkorn Business School, Chulalongkorn University, Thailand. Volunteer participants wrote down the date and time they wished to participate in the experiment. Each participant came to his/her appointment that was arranged individually. The participant was then informed about the data collection procedure. To simulate the situation of using a restaurant review website, the participant was instructed to assume that he/she was looking at the review web page to find information about a restaurant. For the fixation data collection, the researcher adjusted the Mirametrix S2 Eye Tracker for each participant and conducted the device calibration process. The researcher started recording eye gaze data when the restaurant review web page was shown to the participant. The participant was instructed to close the web page immediately after he/she finished with the web page. Then, the researcher stopped recording his/her eye gaze. After that, the participant answered questions about the restaurant review and filled in his/her demographic data in the questionnaire.

Table 1: Participants' demographic information.

Demographics	Distribution
Gender	35.00% male 65.00% female
Age	93.75% 18-25 years old 6.25% 26-30 years old
Education	93.13% undergraduate 6.87% graduate
Handedness	4.38% left 94.06% right 1.56% both
Internet usage experience	3.44% Less than 5 years 28.12% 5-7 years 68.44% More than 7 years
Interest in banner ads	61.25% Interested 38.75% Uninterested

Source: This study.

Participants

In total, 320 undergraduate and graduate students from Chulalongkorn Business School, Chulalongkorn University, Thailand, participated in the study. The demographics of these 320 volunteer participants are presented in Table 1. The participants are 35% male and 65% female. They are mostly undergraduate students, 18 to 25 years old. 94% of them are right-handed. 68% of them have more than 7 years of Internet usage experience, and 61% of them are interested in banner ads in general.

RESEARCH RESULTS

There are two sections of the study results. The first section presents descriptive statistics of the collected data, and the second section demonstrates the hypothesis testing results.

Descriptive Statistics

Participants and banner ads

A total of 320 participants were randomly assigned to four different web pages (as shown in Figure 3 to Figure 6) equally, 80 participants each. However, 37 participants (11.56%) did not have any fixation on the banner ads. In other words, they did not look at the banner ads at all. Table 2 presents numbers and percent values of participants who look/do not look at the banner ads at each position of the web page. It is found that most participants (more than 90%) looked at the banner ad at the left or right position. However, almost 20% of the participants did not look at the banner ad at the top or bottom position at all.

Table 2: Participants who look/do not look at banner ads.

Banner Ad Position	Participants Who Look at Banner Ads	Participants Who Do Not Look at Banner Ads	Total Participants
Top	67	13	80
	83.75%	16.25%	
Bottom	66	14	80
	82.50%	17.50%	
Left	76	4	80
	95.00%	5.00%	
Right	74	6	80
	92.50%	7.50%	
Total	283	37	320
	88.44%	11.56%	

Source: This study.

After discarding data of 37 participants who did not look at the banner ads at all, the descriptive statistics of time to first fixation, first fixation duration, total fixation duration, and fixation count of the remaining participants are presented in Table 3. Figures 9, 10, 11, 12 show density distributions of time to first fixation, first fixation duration, total fixation duration, and fixation count, respectively.

Time to first fixation

Table 3 and Figure 9 indicate that, on average, it took about 13 seconds for participants to take a first look at the banner ads on the web page. It took longer, about 28 seconds on average, for them to take a first look at the banner ad at the top position. On the other hand, the banner ad at the right position seemed to get immediate attention from participants, about 6.5 seconds on average. The results show that all participants took the first look at the banner ad in the left position within the first 2 minutes. However, it took some participants almost 4 minutes to notice the banner ad at the top position.

First fixation duration

From Table 3 and Figure 10, it is found that, on average, participants spent around 0.18 seconds looking at the banner ads for the very first time. There is not much difference in the average time spent looking at the banner ads for the first time among different banner ad positions. However, some participants spent almost 1 second in their first look at the banner ad at the bottom position.

Table 3: Descriptive statistics of the results of each banner ad position.

Banner Ad Position		Time to First Fixation (Sec.)	First Fixation Duration (Sec.)	Total Fixation Duration (Sec.)	Fixation Count (Number of Times)	N
Top	Min	1.000	0.009	0.013	1	67
	Max	237.000	0.777	12.510	103	
	Mean	27.760	0.190	1.980	15.030	
	Std. Deviation	57.640	0.170	2.510	18.450	
Bottom	Min	1.000	0.005	0.041	1	66
	Max	195.000	0.914	21.863	58	
	Mean	10.450	0.180	1.590	12.020	
	Std. Deviation	30.210	0.210	2.890	9.600	
Left	Min	1.000	0.004	0.016	1	76
	Max	120.000	0.723	4.153	63	
	Mean	8.390	0.160	1.080	9.830	
	Std. Deviation	20.360	0.160	0.900	8.700	
Right	Min	1.000	0.005	0.033	1	74
	Max	144.000	0.655	4.590	29	
	Mean	6.590	0.190	1.260	8.960	
	Std. Deviation	20.150	0.170	1.080	6.160	
Total	Min	1.000	0.004	0.013	1	283
	Max	237.000	0.914	21.863	103	
	Mean	12.990	0.180	1.460	11.340	
	Std. Deviation	35.680	0.170	2.010	11.680	

Source: This study.

Total fixation duration

From Table 3 and Figure 11, on average, participants spent about 1.5 seconds in total to look at the banner ads. The banner ad at the top position gained the most attention, on average of almost 2 seconds in total. Some of the participants spent more than 12 seconds looking at the banner ad at the top position. However, interestingly, some participants spent up to 22 seconds looking at the banner ad at the bottom position. The banner ads at the left and right positions gained similar attention from the participants.

Fixation count

Relating to the number of times people look at banner ads, or fixation count, it is found from Table 3 and Figure 12 that participants looked at banner ads around 11 times on average. Participants looked at the banner ads at the top position on average 15 times and up to more than 100 times, more often than the banner ads at other positions on the web page.

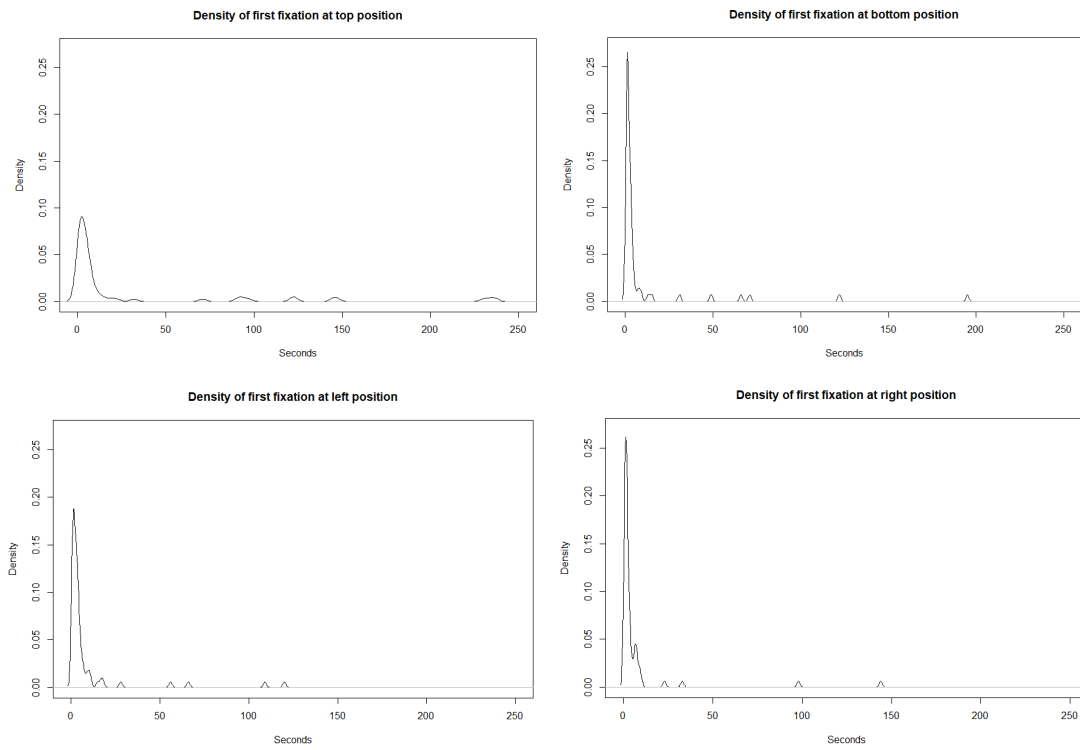

Source: This study.

Figure 9: Distributions of time to first fixation of each banner ad position.

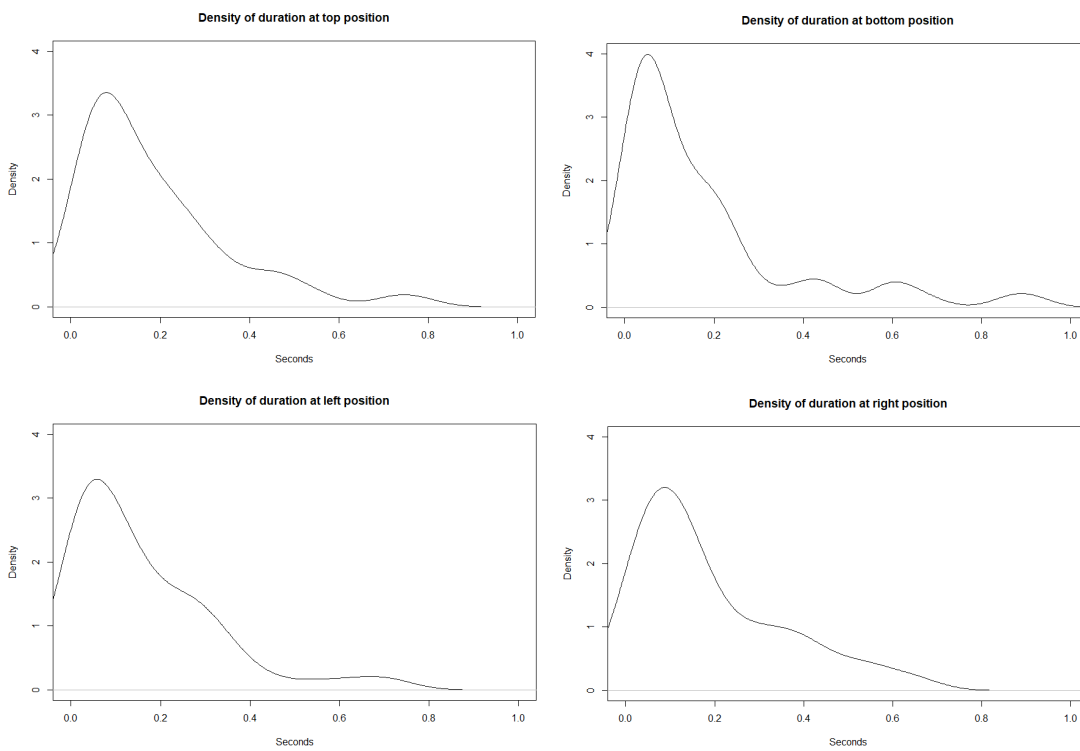

Source: This study.

Figure 10: Distributions of first fixation duration for each banner ad position.

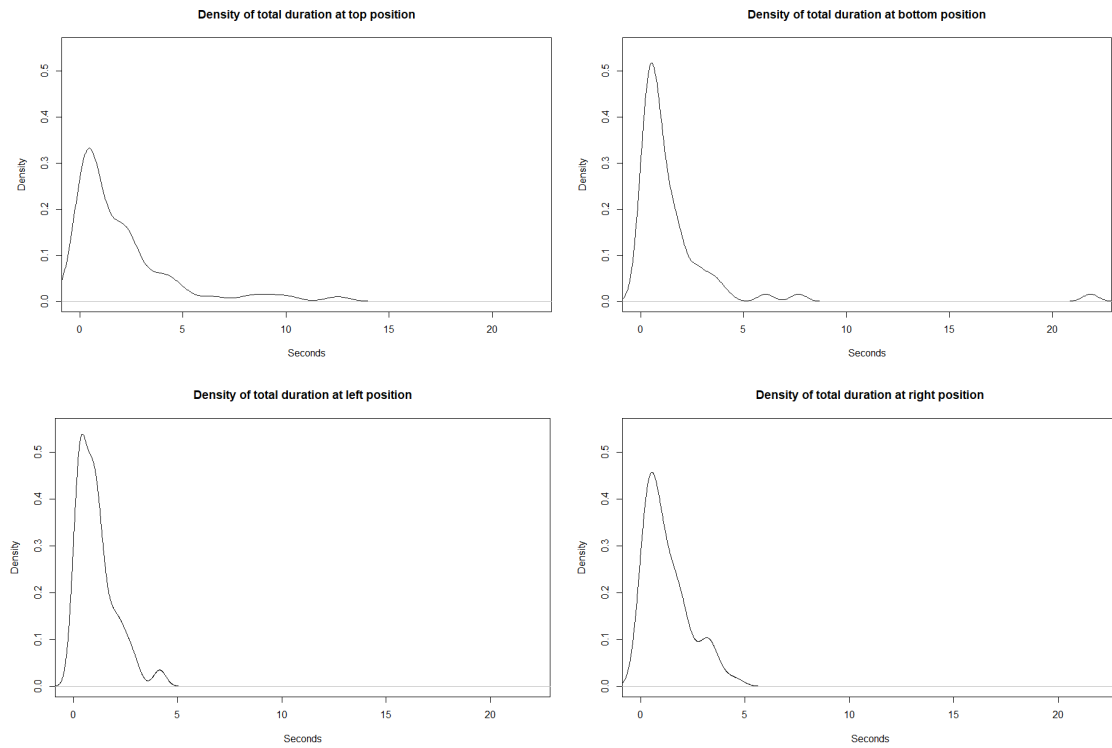

Source: This study.

Figure 11: Distributions of total fixation duration for each banner ad position.

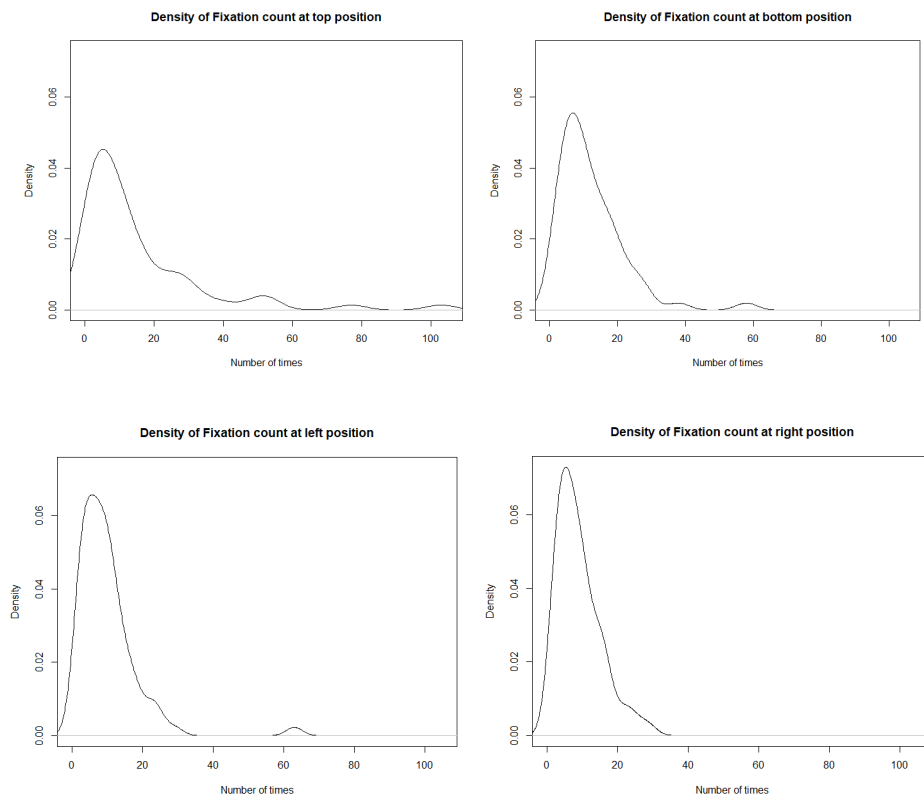

Source: This study.

Figure 12: Distributions of fixation count for each banner ad position.

Hypothesis Testing Results

Hypothesis testing is performed to answer our research question whether different banner ad positions in a web page impact time to first fixation, first fixation duration, total fixation duration, and fixation count. Since distributions of the data are not normal, non-parametric tests are employed. Kruskal-Wallis test results are presented in Table 4.

Table 4: Kruskal-Wallis test results when banner ad positions are different.

	Time to First Fixation	First Fixation Duration	Total Fixation Duration	Fixation Count
Kruskal-Wallis Chi-square	14.9700	3.5068	1.7907	3.7994
df	3	3	3	3
p-value	0.0018**	0.3199	0.6170	0.2840

Source: This study.

** significant at 95% confidence interval

From Table 4, at a 95% confidence interval, Kruskal-Wallis test results indicate that there are significant differences of time to first fixation among the four banner ad positions. However, the test results show no significant difference in first fixation duration, total fixation duration, and fixation count among the four banner ad positions. Hence, further analysis is performed on time to first fixation. Pairwise comparison using Wilcoxon Rank Sum tests in Table 5 and descriptive statistics in Table 3 suggest that it takes significantly longer for people to take a first look at the banner ad at the top position of a web page, at a 95% confidence interval.

Table 5: Wilcoxon Rank Sum Pairwise comparison test on time to first fixation.

Pairwise Comparison	p-value
Top & Bottom	0.0016**
Top & Left	0.0460**
Top & Right	0.0013**
Bottom & Left	0.0931
Bottom & Right	0.9983
Left & Right	0.0850

Source: This study.

** significant at 95% confidence interval

DISCUSSION AND CONCLUSION

It can be concluded from this study that there are differences in how people look at banner ads placed at different positions on a web page. A significant difference is especially found in time to first fixation or the amount of time it took the volunteers to look at the banner ads for the very first time. Statistical analyses indicate that it took significantly longer for people to take a first look at the banner ad at the top position than the other three positions on the web page. From the mean value of time to the first fixation, it took a much shorter time for people to take a first look at the banner ad in the right position. Moreover, it is also found that more than 90% of the participants noticed the banner ad placed at the left or the right position of the web page. On the other hand, almost 20% of the participants did not look at the banner ad placed at the top or the bottom position at all. However, for those who noticed banner ads, when we consider the number of times people look at them (or fixation count) as well as total time spent looking at them (or total fixation duration), the banner ad at the top position gained more attention from participants than the banner ads placed at the other positions.

These conclusions can help internet vendors in deciding where to place banner ads on a web page. Banner ads at the top position seem to gain more attention from audiences even though it takes a much longer time for people to notice them. However, placing banner ads at the top position usually costs more than other positions on a web page. Therefore, it is interesting to consider alternative positions to place banner ads, for example, the right position on a web page. With the lower cost to advertise and the reason that people seem to notice the banner at this position immediately. If internet vendors make the banner ads more attractive, people might spend more time looking at the banner ads placed at this position.

FURTHER WORK

We observe that the empirical results obtained from horizontal banner ads (banner ads placed at the top and bottom positions) are rather different from the results obtained from vertical banner ads (banner ads placed at the left and right positions). The vertical banner ads seemed to be more attractive to the participants. It took a shorter time for the participants to take a first look at them than the horizontal banner ads. However, in terms of total fixation duration and fixation count, the horizontal banner ads seemed to get more attention from the participants than the vertical ones. We plan to conduct further analyses of this observation because it can lead to a clearer recommendation for internet vendors on the choices of banner ads. For example, if people do not spend much time on the vertical banner ads because an alignment of text is not in the direction that they are accustomed to, a banner ad of larger size that is placed on the left or, in particular, the right position may be more attractive and attentive for the web audience. Also, if the horizontal and vertical banner ads are significantly different in terms of time to first fixation and total fixation duration, both types of banner ads can be designed such that internet vendors can benefit most from their choices of banner ad positions. Furthermore, it is interesting to study effective banner ads' position on screens of mobile devices especially smartphones, the main devices used to access websites these days. This is because they are usually held in portrait orientation, which limits the display of banner ads in the left and right positions.

ACKNOWLEDGEMENT

The authors acknowledge “Chulalongkorn Academic Advancement into Its 2nd Century Project (CUAASC)” for financial support and the Business Visualization Research Group, Chulalongkorn Business School, Chulalongkorn University for the Mirametrix S2 Eye-tracker used in this study.

REFERENCES

- [1] Heinz, S., & Mekler, E. D. (2012, October). The influence of banner placement and navigation style on the recognition of advertisement banners. In *Proceedings of the 7th Nordic Conference on Human-Computer Interaction: Making Sense Through Design* (pp. 803-804).
- [2] Hervet, G., Guérard, K., Tremblay, S., & Chtourou, M. S. (2011). Is banner blindness genuine? Eye tracking internet text advertising. *Applied Cognitive Psychology*, 25(5), 708-716.
- [3] John, D. A., & Sathiyaseelan, A. (2014). The effect of the positioning of webpage banner advertisements on implicit and explicit memory. *Global Journal of Commerce & Management Perspective*, 3(2), 120-124.
- [4] Koetsier, J. (2020). COVID-19 accelerated e-commerce growth '4 to 6 years'. Retrieved from <https://www.forbes.com/sites/johnkoetsier/2020/06/12/covid-19-accelerated-e-commerce-growth-4-to-6-years/> (accessed 25 October 2020).
- [5] Lee, J., & Ahn, J. H. (2012). Attention to banner ads and their effectiveness: An eye-tracking approach. *International Journal of Electronic Commerce*, 17(1), 119-137.
- [6] Lindlahr, S. (2020). Digital advertising report 2020 - Banner advertising. Retrieved from <https://www.statista.com/study/38344/digital-advertising-report-banner-advertising/> (accessed 25 October 2020).
- [7] Myers, L. (2020). Google Display ad sizes 2020: Everything you need to know. Retrieved from <https://louisem.com/282251/google-display-ad-sizes/> (accessed 25 October 2020).
- [8] Porta, M., Ravarelli, A., & Spaghi, F. (2013). Online newspapers and ad banners: an eye tracking study on the effects of congruity. *Online Information Review*, 37(3), 405-423.
- [9] Ryu, G., Lim, E. A. C., Tan, L. T. L., & Han, Y. J. (2007). Preattentive processing of banner advertisements: The role of modality, location, and interference. *Electronic Commerce Research and Applications*, 6(1), 6-18.
- [10] Saowwapak-adisak, A., Mongkolnavin, J., & Rattanawicha, P. (2015). Impact of banner ad position, congruence of banner ad content and website content, and advertising objective on banner ad fixation, brand awareness, and product knowledge: An empirical study of a review website in Thailand. In *Proceeding of the Fifteenth International Conference on Electronic Business* (pp. 291-298). ICEB'15, Hong Kong, China, December 6-10.
- [11] Statista.com. (2020). E-commerce worldwide. Retrieved from <https://www.statista.com/study/10653/e-commerce-worldwide-statista-dossier/> (accessed 25 October 2020).
- [12] Tangmanee, C. (2016). Fixation and recall of YouTube ad banners: An eye-tracking study. *International Journal of Electronic Commerce Studies*, 7(1), 49-76.

Personalized Music Recommendation Based on Style Type

(Full Paper)

Yixi Li, Sichuan University, China, liyixi_lesoleil@163.com

Mandie Liu, Sichuan University, China, liu_mandie@163.com

Fu He, University of Electronic Science and Technology of China, China, hefukevin@163.com

Liangqiang Li*, Sichuan Agricultural University, Chengdu, China, lilq@sicau.edu.cn

ABSTRACT

As Internet industry constantly develops and the computer penetration rate continues to grow, the number of online music platforms and music users has been able to increase year by year. With that comes more music choices, information overload has become a very prominent problem. Therefore, how to make users choose their favorite music more conveniently is one of the most challenging problems faced by online music recommendation systems. This paper bases on the existing recommendation system research and uses the collaborative filtering algorithm, proposes a music recommendation method from three perspectives: user attributes, music types and time migration. It is found that the online music recommendation from these three perspectives has a good effect, which can provide a reference for the construction of the current online music recommendation system and is also helpful to platform management practice.

Keywords: Online music, information overload, user attributes, music type, time migration.

*Corresponding author

INTRODUCTION

With the continuous growth of network users and the development of the digital economy, digital consumption has gradually become the norm for household consumption. In the digital economy, digital music consumption accounts for a large part, and people's daily entertainment is increasingly inseparable from digital music, hence the online music market continues to flourish. As the number of music platforms and music continues to increase, users have a wider range of choices and more freedom to choose, which makes the audiences of online music continue to rise. However, as the scale of original music continuously expands, and the number and types of music are growing rapidly, users need to spend a lot of time and energy to find their favorite music. As a result, users' browsing costs rise dramatically. While looking for favorite music, people often browse a lot of irrelevant music information, and in this process, users are prone to encounter the problem of information overload (Bawden, Holtham & Courtney, 1999). An improperly designed platform recommendation system will cause continuous loss of users. Based on the above background, various recommendation methods have begun to be used on music platforms.

In practical applications, the mainstream music platforms now make recommendations based on a single recommendation method. For example, Shrimps Music uses content-based recommendations and Last.fm music station uses system-based filtering recommendations. The accuracy and coverage of these two types of recommendation methods are difficult to guarantee, at the same time, the recommendation effect is often difficult to meet the real needs of users. Indeed, the characteristics of users, the type of music and the time factor in it should be considered in the recommendation process. However, on the current music platform, joint recommendation from the three aspects has not yet been practiced. This study hopes to try a new recommendation method, based on user attributes, music types and time migration to conduct joint recommendation experiments, and hopes to effectively improve the accuracy and coverage of online music platform recommendations in this way.

RESEARCH REVIEW

Traditionally, recommendation systems (RS) are used by e-commerce websites or platforms to provide users with the products and information they need or are interested in, to assist users in making decisions about which products and services to purchase, and to simulate the process of purchasing by salespeople (Pual *et al.*, 1997). The traditional recommendation system consists of three main modules, namely user information, product information and recommendation algorithm. First, user information is collected, then it is matched with product information using recommendation methods, and relevant recommendation methods are used to filter and match users with their favorite music products and information. Currently, there are three main recommendation methods: content-based recommendation, which extracts the main information and most important features of existing products, including the features that users like and dislike, and uses this part of the features and information to match the user's interests and preferences in the modeling, so that it can recommend products and information with a high degree of matching to the user, thus calculating the similarity between music and users in this method (Riyahi & Sohrobi, 2020) is extremely critical. Collaborative filtering recommendation is one of the most widely used and mature recommendation technology in the current major e-commerce platform, which generally uses KNN (K-NearestNeighbor, KNN) technology. Collaborative filtering recommendation method is through the user's product scores, so as to deduce the user's favorite, and then look for its most similar users. In this process, we look at the products that users similar to him like or buy,

and then recommend the corresponding products to the user. The key step is to calculate the similarity between users by calculating cosine similarity (Cheng & Bu, 2020); the recommendation based on association rules mainly considers the rules governing the relationship between users and products, the already purchased products are used as rule headers in the recommendation system, and the recommended objects are the rule body in the recommendation system. By calculating the association rules between different users and different products (Kautz, Selman & Shah, 1997; Wang *et al.*, 2020), we can recommend appropriate products to users, the most classic case is Wal-Mart "beer and diapers", which is widely used in the marketing and management industry. In recommendations based on social network analysis, a social network is a network of relationships formed when people and organizations exchange information, and users often form interrelationships between products and users when they purchase products or browse information on e-commerce web pages, thus forming a social network relationship, through which it is possible to better analyze the correlation between platform users and platform products, and make recommendations based on this correlation (Chen *et al.*, 2019). The mixed recommendation has received extensive attention. Because now many recommend methods have their own limitations, such as content-based recommendations often face the problem of cold start, collaborative filtering recommendation methods are often faced with data sparsity and other issues, so we can combine the advantages of various recommendation methods. The mixed recommendation method is a method that combines the strengths and weaknesses of various recommendation methods after considering the advantages and disadvantages of the existing recommendation methods. At present, the most widely used hybrid recommendation in recommendation systems is to combine the collaborative filtering method and the content-based recommendation method (Basu *et al.*, 1998; Pazzani, 1999; Manogaran, Baratharajan & Priyan, 2018; Logesh & Subramaniaswamy, 2019). For example, Collective Intelligence Social Tagging System (CIST) combines a content-based recommendation approach with a social tagging function based on crowd-sourcing, which makes a significant difference in content-based recommendation system to enrich the item profile and provide more accurate suggestions (Sharma & Kale, 2018; Wang & Sharma, 2018).

Currently, the mainstream music recommendation methods include personalized music recommendation systems based on acoustic metadata (i.e., audio signal analysis), personalized music recommendation systems based on editorial metadata (i.e., expert recommendations), and personalized music recommendation systems based on cultural metadata (i.e., user subjective feelings). Acoustic metadata-based recommendation methods are mainly based on extracting the characteristics of the songs themselves, and such recommendation methods are mainly used in older music recommendation systems, such as audio fingerprinting (Dazhi, 2020), audio acoustic characteristics (Yuan, 2018), and music signals (Gilda *et al.*, 2017). Recommendation systems based on editorial metadata are also known as expert-based recommendation systems, and here experts mainly refer to the singer, lyricist and composer of the song, and this recommendation method is mainly based on collaborative filtering, for example, the famous MoodLogic recommendation system (Celma, 2008) recommends by extracting features and relevant information of the music title, and Celma recommends by using information such as lyrics making recommendations (Celma, 2008). A music recommendation system based on cultural metadata is mainly considered to collect and calculate the subjective feelings of users, which are mainly derived from user reviews, the emotions of the music itself and the genre labels of the music. For example, Knees (2004) make recommendations by classifying artists, Kaji, Hirata and Nagao (2005) calculate similarities by the actions and feedback emotions of users while listening to music. Schedl and Hauger (2012) improved the recommendation algorithm by collecting information such as comments on microblogs and other social media platforms. Francois (2005) provides a detailed summary discussion of different recommendation methods, which is summarized in Table 1.

Table 1: Summary comparison of recommended approaches

Recommended category	Data source	Technology and theory	Recommended advantages	Recommended disadvantages	Typical websites
Content-based online music recommendation	The audio characteristic of the music itself	Word frequency mining and Gaussian mixture models, etc.	Overcoming cold start problems	Low novelty of results	Shrimps music
Collaborative filtering of online music recommendations	User ratings	KNN, NB	Higher novelty	Data sparsity and cold start	Last.fm Music station (Shardanand & Maes, 2012)
Music recommendations based on association rules	Number of comments and retweets shared	Cluster, NB etc.	Personalized recommendation results	Large amount of data to process	Douban Radio Station

Online music recommendations based on social networks	Nodes of Music and Nodes of Users	Random walk model	High accuracy	The structure is more complex	Graph-based MMRF(Lee, 2012)
Hybrid Online Music Recommendations	Combined application of various recommendation methods	DFE	A combination of the above benefits		7HCCMR (Yoshii et al., 2006)

Recommendation systems are currently developing fast and are mostly used in the e-commerce field. Other fields, such as news, movies, music and so on, are now using recommendation systems, but they are developing more slowly and are not as complete as the recommendation systems in the e-commerce field due to the lack of data support in the e-commerce field. Most of the existing music recommendation systems are based on acoustic metadata, editorial metadata, and cultural metadata, and these recommendation systems also have more or less different problems. For example, music recommendation systems based on acoustic metadata cannot represent the music well due to the characteristics of each frame of the music, and therefore the recommendation results cannot really satisfy the users; music recommendation systems based on editorial metadata take the information of experts into account too much, which leads to excessive human costs; music recommendation systems based on cultural metadata need a lot of user feedback information to reach a more accurate recommendation effect. Therefore, this study has theoretical and practical significance to research the personalized music recommendation system from the perspective of music genre, user attributes and time migration.

THEORETICAL BACKGROUND AND MODEL

Theoretical Background and Model

Based on the previous analysis, we will explain and introduce the algorithm and recommended metrics that will be used in this study. Currently, collaborative filtering is mainly carried out by Top-N algorithm, so this study will mainly use this algorithm for the calculation. The sparse linear recommendation algorithm (SLIM) in Top-N can be used to build user matrices through Model-based and predict similarity through Neighborhood-based calculation. In this study, the similarity matrix is built and then similarity calculation is performed to generate the recommendation using KKN. The following section introduces the music genre rating optimization algorithm as well as the recommendation metrics that will be used in the experiment.

Construction of the Similarity Matrix

In every experiment of recommendation system, the recommendation method is the central key, and this experiment uses a combination of user similarity and the type of song to calculate the recommendation. The first step is the construction of a matrix, which is built with the purpose of exploring users' ratings of songs they listened to at different times, so that it is possible to see if their preferences change over time migration. The matrix is decomposed by formula (1).

$$R_{m*n} \approx P_{m*k} * Q_{k*n} = \hat{R}_{m*n} \quad (1)$$

Definition:

P_{m*n} : represents the relationship between m users and k songs.

Q_{m*n} : represents the relationship between k songs and n users.

The matrix decomposition structure is shown in Figure 1.

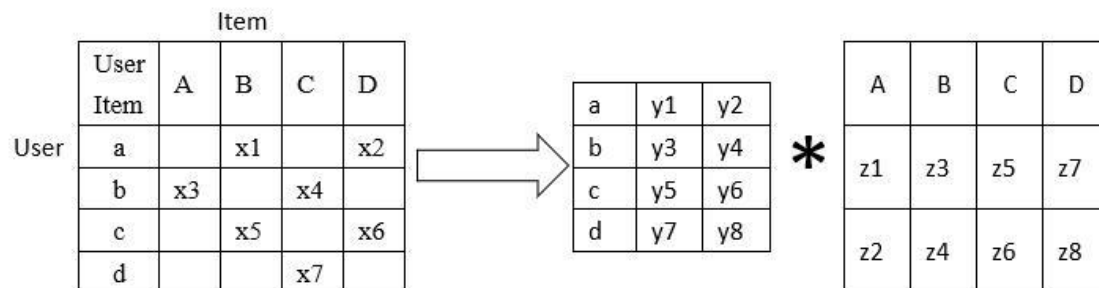

Figure 1: Matrix decomposition

Similarity Calculations

According to the previously established similarity matrix to calculate the user similarity, using the cosine angle formula to calculate the similarity between the user now and previously listened to the song list, by calculating the user ratings on their own at different times to listen to the song, so that the recommendation can be considered from the perspective of both user attributes and time migration, the main use of as formula (2).

$$w_{u,v} = \frac{|N_u \cap N_v|}{\sqrt{|N_u| |N_v|}} \quad (2)$$

Definition:

u: represents the song u.

v: represents the song v.

N_u: represents how much the song u is liked by the user.

N_v: represents how much the song v is liked by the user.

Recommendations Generated by KNN

Secondly, the K Nearest Neighbor algorithm is used to train the recommendation model. Since this experiment is based on the score of the Item to make predictions, the K Nearest Neighbor algorithm (KNN) is chosen in this study to train the recommendation model.

The KNN algorithm, commonly called K nearest neighbor algorithm, is used to generate recommendations by calculating the similarity of the nearest K users to the target user, as in formula (3).

$$d(u, v) = \sqrt{\sum_{k=1}^n |u_k - v_k|} \quad (3)$$

Definition:

d: represents the spatial distance between two users.

u_k: represents the K neighbors of user u.

v_k: represents the K neighbors of user v.

Score Optimization Algorithm for Music Genres

This study focuses on making recommendations based on music genres, and the most direct basis for recommendations is the user's rating of the music (Xiang, 2012) Therefore, this experiment focuses on the users' liking for that music genre. Currently, the most dominant music genres on NetEase music platform are shown in Table 2.

Table 2: NetEase cloud music style

Main Category	Subcategories
Language	Chinese, European and American, Japanese, Korean, Cantonese, Small languages
Style	Pop, Rock, Folk, Electronic, Dance, Rap, Light Music, Jazz, Country, R&B/Soul, Classical, Ethnic, British, Metal, Punk, Blues, Reggae, World Music, Latin, Alternative/Indie, New Age, Ancient, Post-rock, Bossa Nova
Scene	Morning, evening, study, work, lunch break, afternoon tea, subway, driving, sports, travel, walking, bar
Emotion	Nostalgic, fresh, romantic, sexy, sentimental, healing, relaxing, lonely, emotional, excited, happy, quiet, nostalgi
Theme	Soundtrack, ACG, Children, Campus, Game, Post 70s, Post 80s, Post 90s, Internet Song, KTV, Classical, Cover, Guitar, Piano, Instrumental, List of Names, Post 00s

Source: Top song list categories are style, theme, emotion, scene, and language, and the data used in this study mainly considers "style".

Based on the ranking of the amount of data available, this study mainly selected pop, rock, folk, rap, electronic, light, R&B, classical, and jazz music, each of which has one to three style types for users to choose. The style type is used to evaluate the user's preference for the song, and the formula (4) is used to calculate the user's rating of the music style type.

$$r_{ui} = \sum_b \frac{T_{uib} S_{ub}}{S_u} \quad (4)$$

Definition:

b: represents the type of music style.

T_{uib}: is a boolean data of type b for whether user u has selected a style type for music i or not.

S_{ub}: represents the total number of music styles b for user u.

S_u: represents the total number of all style types selected by user u.

α : is a correction factor.

Recommended Indicators

The main metrics for evaluating a recommendation system are accuracy, recall, coverage and novelty. Because of the low cost of goods shelves on the Internet, it is possible to sell goods at lower prices than offline on many e-commerce sites (Su *et al.*, 2018). At the same time, with the continuous development of the Internet and computers and the changing needs of users, many new evaluation metrics have emerged in the field of recommendation systems. For example, the evaluation index of accuracy is a kind of measurement index suitable for offline experiments, which is a more common metric that measures the predictive ability of recommendation systems.

The common accuracy evaluation mainly includes Top-N prediction method and score prediction. Wherein, Top-N is the first N items to determine whether users are satisfied with the recommendation system to generate recommendations, while score measurement mainly uses accuracy, coverage and novelty (Celma, 2010), diversity (Deldjoo *et al.*, 2016), surprise (Abbas & Niu, 2019), root mean square error (RMSE) (Patro *et al.*, 2020), and mean absolute error (MAE) to determine whether users will be Recommended content gives a higher rating, as shown in formula (5) and (6).

$$\text{Precision} = \frac{\sum_{u \in U} |R(u) \cap T(u)|}{\sum_{u \in U} |R(u)|} \quad (5)$$

$$\text{Recall} = \frac{\sum_{u \in U} |R(u) \cap T(u)|}{\sum_{u \in U} |T(u)|} \quad (6)$$

Definition:

R(u): list of recommendations made on the training set.

T(u): list of recommendations made on the test set.

In this study, we take advantage of the special surprise library of the Python recommendation system, and use the KNN collaborative filtering algorithm in the surprise library function to model the existing data and make similar song list predictions based on the calculations.

EXPERIMENTAL FRAMEWORK AND RESULTS

This study considers the recommendation system construction from three perspectives: user attributes, song type and time migration. The data is collected by crawler, pre-processed including data cleaning, and then undergoes six experimental steps including offline experiments such as user attribute modeling, establishment of similar matrix in collaborative filtering, style scoring, index testing, KNN nearest neighbor algorithm, and index testing to finally generate recommendation results.

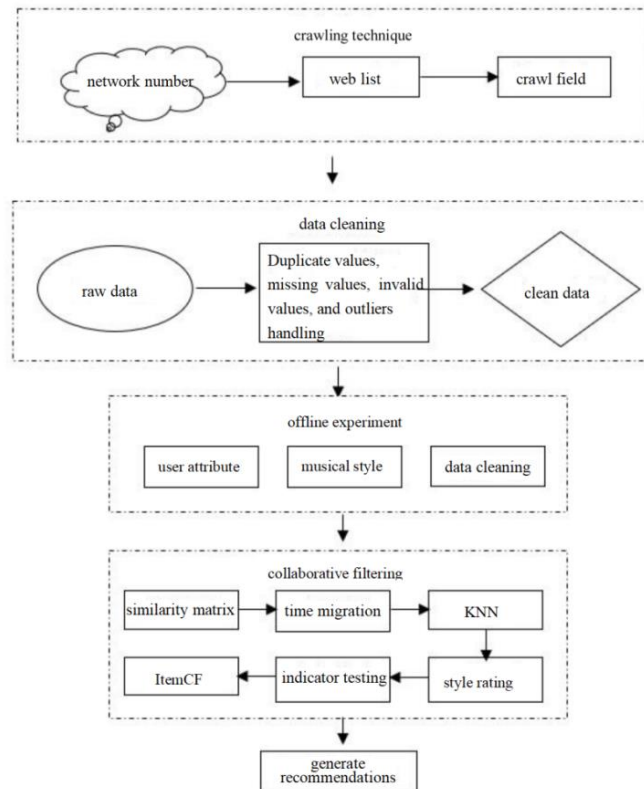

Figure 2: Technology road map

Data Acquisition and Pre-processing

The data in this study is mainly from the NetEase cloud music platform, which has a larger number of listeners and more complete song information. A crawler program written in Python was used to crawl 66291 data information from NetEase cloud music platform. The main fields of data crawled in this study are song list id, music genre of the song list, number of times the song is played, artist, song release time, song duration and other song related field fields.

The data in this study still needs to be in the recommended system format, so in order to facilitate the participation in the calculation and adapt to the needs of the current Python surprise library and the most mainstream recommended system framework, the data format is processed into the most basic format of the library, movielens dataset. The processed data are shown in Figure 4.

Website	id	01_kind	02_kind	create_time	favorite_count	share_count	comment_count	play_count	playlist_count
http://mus	375661355	Subject	After 90	2016/5/5	378664	8285	5243	22238996	178
http://mus	378324005	Language	Chinese	2016/5/9	439451	6161	1441	21703896	210
http://mus	554473977	Subject	List	2017/1/1	283964	2592	2955	20803614	100
http://mus	498708023	Language	Chinese	2016/10/30	464891	6006	2561	20403924	200
http://mus	440561933	Language	Europe and America	2016/8/10	546976	6139	2650	20364706	100
http://mus	758106745	Emotion	Nostalgia	2017/6/10	203546	1171	959	19682608	300
http://mus	497639728	Language	Video Soundtrack	2016/10/29	262802	1485	718	19142126	50
http://mus	375779419	Subject	Excitement	2016/5/5	500907	18925	3743	18364244	59
http://mus	331398396	Emotion	Nostalgia	2016/4/6	500601	5323	1921	17436642	92
http://mus	417794815	Emotion	Chinese	2016/7/8	239929	2131	995	17351472	101
http://mus	330634870	Language	Europe and America	2016/4/5	475196	3379	2642	17258234	181
http://mus	504347934	Language	Chinese	2016/11/7	462340	3291	1241	17223906	53
http://mus	374012053	Language	Europe and America	2016/5/2	267265	1901	1060	16401452	104
http://mus	427850291	Style	Rock and Roll	2016/7/22	478410	3533	2861	16243550	55
http://mus	818563810	Scene	Evening	2017/7/21	337444	11287	22277	15164669	41
http://mus	171664498	Style	Electronic	2016/2/18	683050	13507	3216	15085841	76
http://mus	153864251	Style	Electronic	2016/1/14	313006	2957	1646	14168671	344
http://mus	308905952	Subject	Video Soundtrack	2016/2/28	394877	4910	2209	14157364	100
http://mus	399723525	Language	Europe and America	2016/6/12	433802	6576	2366	14107973	67
http://mus	458329079	Language	Europe and America	2016/9/5	393350	2902	1276	14090920	15
http://mus	517438933	Emotion	Sentimental	2016/11/23	348668	3017	829	13973394	78
http://mus	698720887	Language	Europe and America	2017/4/16	178391	866	517	13914202	101
http://mus	367649303	Emotion	Alone	2016/4/22	341332	2477	1888	13870706	117
http://mus	307592533	Language	Europe and America	2016/2/25	191853	1886	2091	13323389	44
http://mus	449559997	Style	World Music	2016/8/23	354523	3601	2423	13312312	76

Figure 3: Examples of partial data shots

The Id represents the id value of the song list; kind represents the style type of the song list, which is used for the later style rating calculation; create_time, which represents the creation time, is used for the later time migration calculation; and the data

in the latter column are the number of collections, number of shares, number of comments, number of plays and number of songs, which will be used in the further research in the future.

Modeling

The online music recommendation system is similar to the traditional recommendation system model, which mainly consists of three parts: user information module, music resource model, i.e., recommendation object modeling, and personalized music recommendation algorithm, as shown in Figure 8.

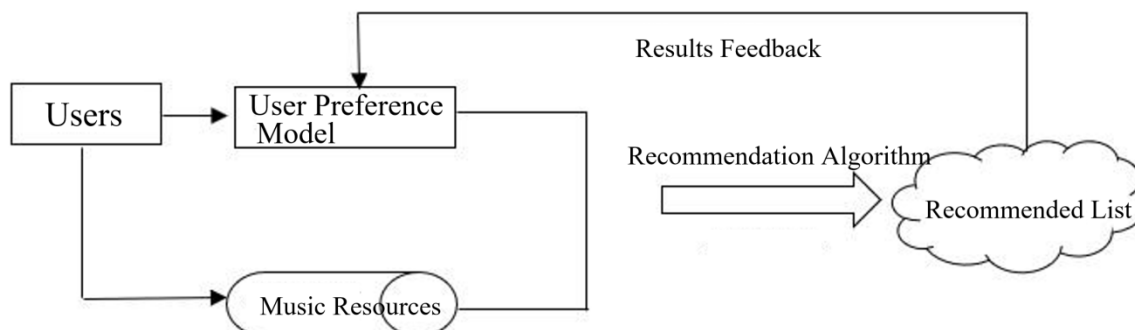

Figure 4: Modeling

The focus of this research experiment is on the music resource module, which mainly contains some information about the song list: song list ID, number of songs, singer and music style and so on, and the recommendation is mainly based on the music style information in it.

At the same time, we can see from the previous three methods that content-based recommendations have less available data in the music domain, and at the same time, they are difficult to implement and difficult to discover new user preferences, so the novelty of recommendations is relatively small; recommendations based on association rules consider fewer objects and have a lower coverage rate; music recommendations based on social networks have a large computation volume and a complex structure, and often require cross-platform integration of data. Therefore, each of the three methods has its own advantages and disadvantages.

The collaborative filtering recommendation algorithm used in this study can well avoid the disadvantages of the above three methods through user attributes, style types and time migration perspectives, and at the same time the computation volume is relatively small, which is used in all major music platforms at present.

Experimental Setup

There are three main common experimental methods used in the recommended system, including User Study, Offline Experiment and Online experiment. In this study, the experimental method is mainly an offline experiment. In this study, the existing dataset is divided into two datasets according to the data length of 8:2, the former is the Training Set and the latter is the Test Set.

Collaborative filtering recommendation algorithm mainly includes two kinds, one is the user-based collaborative filtering algorithm UseCF, the other is the product-based collaborative filtering algorithm and ItemCF, in the beginning of the experiment using a small portion of data to compare the two algorithms, this study takes $K = 10$, the results are shown in Table 3.

Table 3: UserCF and ItemCF

	UserCF	ItemCF
Recall	0.41348	0.43487
Precision	0.37293	0.40143
Popularity	3.45781	3.27159
Coverage	0.51246	0.53841

According to the data in the above table, the indicators of user-based collaborative filtering algorithm, i.e., UserCF, including Recall, Precision, Popularity and Coverage are lower than product-based collaborative filtering algorithm, i.e., ItemCF, so the product-based collaborative filtering algorithm is used in this study.

In this study, in order to find the most appropriate K value, the ItemCF was taken for $K=5,10,20,30$ respectively, and the specific results are shown in Table 4.

Table 4: ItemCF at different K values

K	5	10	20	30
Recall	0.30142	0.32157	0.45841	0.39281
Precision	0.27364	0.31921	0.38805	0.35421
Popularity	3.10323	3.11451	3.14276	3.15834
Coverage	0.51348	0.51967	0.50124	0.49523

According to the results of the above table, it can be seen that as the value of K increases, the recall and accuracy rates appear to increase and then decrease. The highest recall and accuracy rates are 0.45841 and 0.38805 when K is taken as 20, which can be determined that the algorithm is more accurate when K = 20 in this study.

In this study, the song types are classified first and then the user ratings of different types of songs are calculated for recommendation, but in order to study the effect of different K values, so the UserCF is then calculated separately when K=5,10,20,30; the specific results are shown in Table 5.

Table 5: UserCF under different K-values

K	5	10	20	30
Recall	0.31121	0.33429	0.34957	0.34281
Precision	0.15481	0.16249	0.27543	0.16329
Popularity	3.09541	3.11428	3.13027	3.14438
Coverage	0.509128	0.51459	0.50129	0.49499

Through the experimental comparison, we can see that when K=5,10,20,30, the two tables change the same rule, that is, when K takes these four values, ItemCF and UserCF have the same properties. At the same time, when K=20, the system's Recall and Precision are higher, indicating that it is most appropriate to take the value of K. So the experiment shows that when K takes the appropriate value, the system's Recall and Precision are higher. So the experiments show that when K takes the appropriate value, the accuracy and coverage of the recommendations of the collaborative filtering recommendation algorithm based on music style classification are higher.

Recommended Results

The experiment generates recommendations by KNN algorithm and then calculates the scores of the recommended results by music genres, and selects the type of music style suitable for the user from the recommended results. In this study, the user with ID 803 is selected as an example, and the five users with the highest similarity to this user are found by calculating the five songs with the highest scores from the recommended 20 receipts, as shown in Table 6.

Table 6: Similar Users

User ID	Similarity
1026	0.61582
8426	0.61081
15687	0.60753
19230	0.59884
29321	0.59741

The recommended songs are shown in Table 7.

Table 7: Recommended song titles and artists

Song Title	Singer
Trouble I'm In	Twinbed
Gravity	Coldplay
One day	Emblem3
What Are Words	Chris Medina
I Like Me Better	Lauv

COMPARISON OF EXPERIMENTAL RESULTS

User-based Recommendations

This recommendation method is based on a collaborative filtering approach by calculating the similarities between users, using the user ID of 803 in the dataset as an example to recommend the top five songs in terms of similarity, as shown in Table 8.

Table 8: Recommended results based on users

Song ID	Similarity
142902542	0.327551
120213287	0.325473
308313843	0.319276
360062344	0.315423
531321323	0.308436

Music-based Recommendations

Music-based recommendations are mainly used to calculate the similarity between the songs listened to by the user and then to find songs that are more similar to future songs to recommend to the user. Similarly, using the word2vec model, the similarity is calculated by the number of likes of the songs in the song list ID of 110759778. Similarly, the top five songs with similarity are recommended, and the results are shown in Table 9.

Table 9: Recommended results based on music

Song ID	Similarity
115900031	0.319823
498708023	0.3176259
331398396	0.3152649
330634870	0.3091537
517438933	0.3056812

Time Migration-based Recommendations

Recommendations based on time migration mainly consider whether the user's music style changes after a period of time, by calculating the similarity of the user's music style at different times to make recommendations, this method is similar to the music-based recommendation method, but the range of songs considered is narrowed to the songs the user listens to.

Table 10: Recommended results based on time migration

Song ID	Similarity
692029375	0.3185233
533197318	0.3169182
256740225	0.3135139
109393127	0.3081456
379133594	0.3069437

From the above analysis, it can be seen that the similarity of recommendations from the three perspectives of user, music style and time migration alone is relatively low, while the accuracy of recommendations from the three perspectives jointly improves significantly.

CONCLUSION AND FUTURE WORK

Based on the collaborative filtering recommendation method, this study finds that the recommendation effect can be optimized by adjusting the K-value by using the KNN algorithm. In addition, this study finds that setting up a combined recommendation algorithm can optimize the recommendation system to some extent. Combined recommendations based on multiple perspectives, such as user attributes, style types and time migration, can well compensate for the shortcomings of other recommendation methods and thus improve the accuracy and coverage of online music recommendation systems. In the online music recommendation system, the style type scoring algorithm is used to calculate the higher score in the recommended songs, and the three perspectives of user attributes, music style and time migration are analyzed, and the recommendation system is constructed by combining these three perspectives. To a certain extent, the final recommendation result satisfies the user's music preferences, can better improve the accuracy of the recommendation system, and provide a reference for improving the algorithm design of the current online music recommendation system.

Through this research, it can be seen that the joint design based on user attributes, music style type and time transfer can more accurately recommend the music that users like, but this experiment also has some shortcomings. For example, the existing artificial intelligence such as deep learning has begun to be applied to the field of recommendation systems, and this research did not consider and test such technologies. This will also be a future development direction of online music recommendation systems, and future research can be explored in this direction.

REFERENCES

- [1] Abbas, F., & Niu, X. (2019). One size does not fit all: Modeling users' personal curiosity in recommender systems. Retrieved from <https://arxiv.org/abs/1907.00119> (December 1, 2020).
- [2] Basu, Chumki, Hirsh, Haym & Cohen, William. (2000). Recommendation as classification: using social and content-based information in recommendation. Proceedings of AAAI-98.
- [3] Bawden, D., Holtham, C., & Courtney, N. (1999). Perspectives on information overload. *Aslib Proceedings*, 51(8), 249-255.
- [4] Celma, O. (2010). Music recommendation. In *Music recommendation and discovery* (pp. 43-85). Springer, Berlin, Heidelberg.
- [5] Celma, Ò., & Serra, X. (2008). FOAFing the music: Bridging the semantic gap in music recommendation. *Journal of Web Semantics*, 6(4), 250-256.
- [6] Chen, L., Yang, Y., Wang, N., Yang, K., & Yuan, Q. (2019). How serendipity improves user satisfaction with recommendations? A large-scale user evaluation. In *The World Wide Web Conference* (pp. 240-250).
- [7] Cheng, Y., & Bu, X. (2020). Research on key technologies of personalized education resource recommendation system based on big data environment. *Journal of Physics: Conference Series*, 1437(1), 012024 (9pp).
- [8] Dazhi, X. U. (2020). Research on music culture personalized recommendation based on factor decomposition machine. *Personal and Ubiquitous Computing*, 24(2), 247-257.
- [9] Deldjoo, Y., Elahi, M., Cremonesi, P., Garzotto, F., Piazzolla, P., & Quadrana, M. (2016). Content-based video recommendation system based on stylistic visual features. *Journal on Data Semantics*, 5(2), 99-113.
- [10] Gilda S, Zafar H, Soni C, et al. (2017). Smart music player integrating facial emotion recognition and music mood recommendation. International Conference on Wireless Communications, Signal Processing and Networking (WiSPNET).
- [11] Kaji, K., Hirata, K., & Nagao, K. (2005, November). A music recommendation system based on annotations about listeners' preferences and situations. In *First International Conference on Automated Production of Cross Media Content for Multi-Channel Distribution (AXMEDIS'05)* (pp. 4-pp). IEEE.
- [12] Kautz, H., Selman, B., & Shah, M. (1997). Referral Web: combining social networks and collaborative filtering. *Communications of the ACM*, 40(3), 63-65.
- [13] Knees, P., Pampalk, E., & Widmer, G. (2004, October). Artist classification with web-based data. In Proceedings of 5th International Conference on Music Information Retrieval (ISMIR '04), pages 517-524, Barcelona, Spain, October 2004.
- [14] Lee, Sangkeun. (2012). A generic graph-based multidimensional recommendation framework and its implementations. WWW'12 - Proceedings of the 21st Annual Conference on World Wide Web Companion.
- [15] Logesh, R., & Subramaniaswamy, V. (2019). Exploring hybrid recommender systems for personalized travel applications. In *Cognitive informatics and soft computing* (pp. 535-544). Springer, Singapore.
- [16] Manogaran, G., Varatharajan, R., & Priyan, M. K. (2018). Hybrid recommendation system for heart disease diagnosis based on multiple kernel learning with adaptive neuro-fuzzy inference system. *Multimedia tools and applications*, 77(4), 4379-4399.
- [17] McNee, S. M., Riedl, J., & Konstan, J. A. (2006, April). Making recommendations better: an analytic model for human-recommender interaction. In *CHI'06 extended abstracts on Human factors in computing systems* (pp. 1103-1108).
- [18] Pachet, F. (2005). Knowledge management and musical metadata. In Schwartz, D. (Ed.) *Encyclopedia of Knowledge Management*, Idea Group, 12.
- [19] Patro, S. G. K., Mishra, B. K., Panda, S. K., Kumar, R., Long, H. V., Taniar, D., & Priyadarshini, I. (2020). A hybrid action-related k-nearest neighbour (HAR-KNN) approach for recommendation systems. *IEEE Access*, 8, 90978-90991.
- [20] Pazzani, M. J. (1999). A framework for collaborative, content-based and demographic filtering. *Artificial intelligence review*, 13(5-6), 393-408.
- [21] Resnick, P., & Varian, H. R. (1997). Recommender systems. *Communications of the ACM*, 40(3), 56-58.
- [22] Riyahi, M., & Sohrabi, M. K. (2020). Providing effective recommendations in discussion groups using a new hybrid recommender system based on implicit ratings and semantic similarity. *Electronic Commerce Research and Applications*, 40, 100938.
- [23] Schedl, M., & Hauger, D. (2012, April). Mining microblogs to infer music artist similarity and cultural listening patterns. In *Proceedings of the 21st International Conference on World Wide Web* (pp. 877-886).
- [24] Shardanand, U., & Maes, P. (1995, May). Social information filtering: algorithms for automating "word of mouth". In *Proceedings of the SIGCHI conference on Human factors in computing systems* (pp. 210-217).
- [25] Sharma, R. S., & Kale, R. (2018). Design of back-end of recommendation systems using collective intelligence social tagging. Paper presented at the 18th International Conference on Electronic Business, ICEB 2018, December 2, 2018 - December 6, 2018, Guangxi, China.
- [26] Su, J. H., Chin, C. Y., Yang, H. C., Tseng, V. S., & Hsieh, S. Y. (2018, March). Music recommendation based on information of user profiles, music genres and user ratings. In *Asian Conference on Intelligent Information and Database Systems* (pp. 528-538). Springer, Cham.
- [27] Wang, F., Wen, Y., Guo, T., Liu, J., & Cao, B. (2020). Collaborative filtering and association rule mining-based market basket recommendation on spark. *Concurrency and Computation: Practice and Experience*, 32(7), e5565.
- [28] Wang, Y., & Sharma, R. S. (2018). Design of front-end for recommendation systems: Towards a hybrid architecture. Paper presented at the 18th International Conference on Electronic Business, ICEB 2018, December 2-6, 2018, Guangxi, China.

- [29] Xiang, L. (2012). Recommended system practice. *Posts and Telecom Press, Beijing*, 184-193.
- [30] Yoshii, K., Goto, M., Komatani, K., Ogata, T., & Okuno, H. G. (2006, October). Hybrid collaborative and content-based music recommendation using probabilistic model with latent user preferences. In *The 7th International Conference on Music Information Retrieval (ISMIR'06)*, Victoria, Canada, 8 - 12 October 2006.

Prediction Markets: A Systematic Review and Meta-Analysis

(Full Paper)

Roberto Louis Forestal*, Chung Yuan Christian, Taiwan, R.O.C., boolfrivie@gmail.com

Peng Cheng Zhang, Chung Yuan Christian, Taiwan, R.O.C

Shih-Ming Pi, Chung Yuan Christian, Taiwan, R.O.C.

ABSTRACT

Prediction markets (PM) have drawn considerable attention in recent years as a tool for forecasting events. Studies surveying and examining relevant the trends of PM using traditional approaches have been reported in the literature. However, research using meta-analysis to review Prediction markets systems is very limited in Management Information System (MIS). This paper aimed to fill this gap by using Preferred Reporting Items for Systematic Reviews and Meta-Analyses (PRISMA) method to study Prediction markets trends over the past decades. Our results are as follows. First, we find that shows that more than 64% of academic studies on Prediction markets are published in top journals such as Journal of the Association for Information Systems, Journal of Consumer Research and Information Systems Research. Second, we showed that Prediction markets applications can be divided into two groups: internal use PMS and general public usage. Finally, our significant meta-analysis result show that on average prediction markets is 79% more accurate than alternative forecast methods based.

Keywords: Prediction markets, systematic literature review, meta-analysis.

*Corresponding author

INTRODUCTION

Throughout history, people have always sought to predict the future of events. Among well-known forecasting methods, markets for information aggregation, such as prediction markets, have attracted the attention of several researchers in the literature. In general, prediction markets are an electronic platform where participants can interact with each other and exchange their beliefs. To measure and reward success, participants receive a payoff either in play money or real money if a certain outcome occurs. Given the growing importance of markets, we wonder how to survey scholarly sources on prediction markets. Most popular types of literature reviews in business studies include: narrative review, argumentative review, theoretical review and systematic review. (Ridley, 2012). Our research purpose is an attempt to systematically review previous academics works related to Prediction Markets (PM) using the Preferred Reporting Items for Systematic Reviews and Meta-Analyses (PRISMA) method. Coined and first applied by Glass (1976), meta-analysis, warmly embraced in experimental fields such as medicine, education and psychology, is a quantitative technique that uses specific measures (e.g., an effect size) to indicate the strength of variable relationships for the studies included in the analysis. The technique emphasizes results across multiple studies as opposed to results from a single investigation.

Prior studies surveyed and examined relevant existing literature on Prediction markets and its trends. Zhao *et al.* (2008) present an analysis of Prediction Market research relevant to Information Systems (IS) from 1985 to 2007. They classified their results in two different ways. On the one side, they develop categories related to the publication outlet based on outlet name and outlet description. On the other side, they assign the articles to research themes. Tziralis and Tatsiopoulos (2007) presented an "Extended Literature Review" on Prediction markets on which they examined journal articles, conference proceedings papers, books and book chapters, master's theses, doctoral dissertations as well as other unpublished academic working papers and reports that were referring to the concept of Prediction Markets. As a result, they identified 155 relevant article to their study, published between 1990 and 2006. Those publications are often served as references literature reviews on prediction markets.

However, reviews of studies on Prediction markets based on meta-analysis are very limited in MIS. Therefore, we plan to fill this gap by using a systematic review and meta-analysis to study Prediction markets trends over the past decades. We calculate a statistic, namely "Effect Estimate" (or effect size) that provides an estimate of the comparison effect for each study. Then we select a meta-analytic effect estimate to synthesize the effect sizes across the studies. Test of heterogeneity will be also performed in order to assesses whether observed differences in results are compatible with chance alone. In relation with the motivation, our analysis contributes to several literatures. First, we relate to an emerging literature studying Prediction markets, its applications and trends. Second, by adapting a method generally used in medical sciences, we show evidence that paradigms are not totally disparate and it is possible to build bridges across blurred paradigm boundaries (Goia and Pitre, 1990).

The remainder of the paper is structured as follows. Section 2 details the methodology used including data selection and effect size calculation. Section 3 presents the results and discussion. The final Section 4 concludes the analysis while elaborating on limitations of the paper.

METHODOLOGY

This research is an attempt to systematically review previous academics works related to Prediction Markets (PM). This systematic review was conducted by following the reporting checklist of the Preferred Reporting Items for Systematic Reviews and Meta-Analyses (PRISMA) method (Liberati *et al.*, 2009). For the purpose of this study, a comprehensive literature search was undertaken online through Web of Science which is one the top electronic libraries and academic databases. More specifically, we developed a protocol to document the analysis method and inclusion criteria. More specifically, all academic works related to prediction markets published from 1975 to 2020 on web of science database as well as those in the Australian Business Deans Council (ABDC) journal quality list were searched for systematic review papers. We choose the ABDC list because it is more comprehensive than other journal ranking lists, such as social sciences citation index (SSCI), Association of Business Schools (ABS), and Scopus (Rainer & Miller, 2005).

Inclusion and exclusion criteria

- Keyword and Timespan: Using the database of ISI Web of Knowledge and typing the keyword “Prediction market” 12,866 papers were identified sorting by “Relevance” from 1975 to 2020.
 - Web of Science Categories: Using “Economics”, “Business Finance”, “Management”, “Business”, “Computer Science Information Systems”, “Multidisciplinary Sciences” “Information Science Library Science” and “Social Sciences Interdisciplinary” as inclusion categories, the number of papers was reduced to 6,629.
 - Open Access and Language: Selecting “English” as a language and “Open Access” as a filter reduced the number to 1,222. Out of which 160 relevant academic works concerning prediction markets were studied.
- For the purpose of our study, we consider 160 relevant researches concerning prediction markets. The title, journal name, and year of publication of the identified records were reported in Appendix.

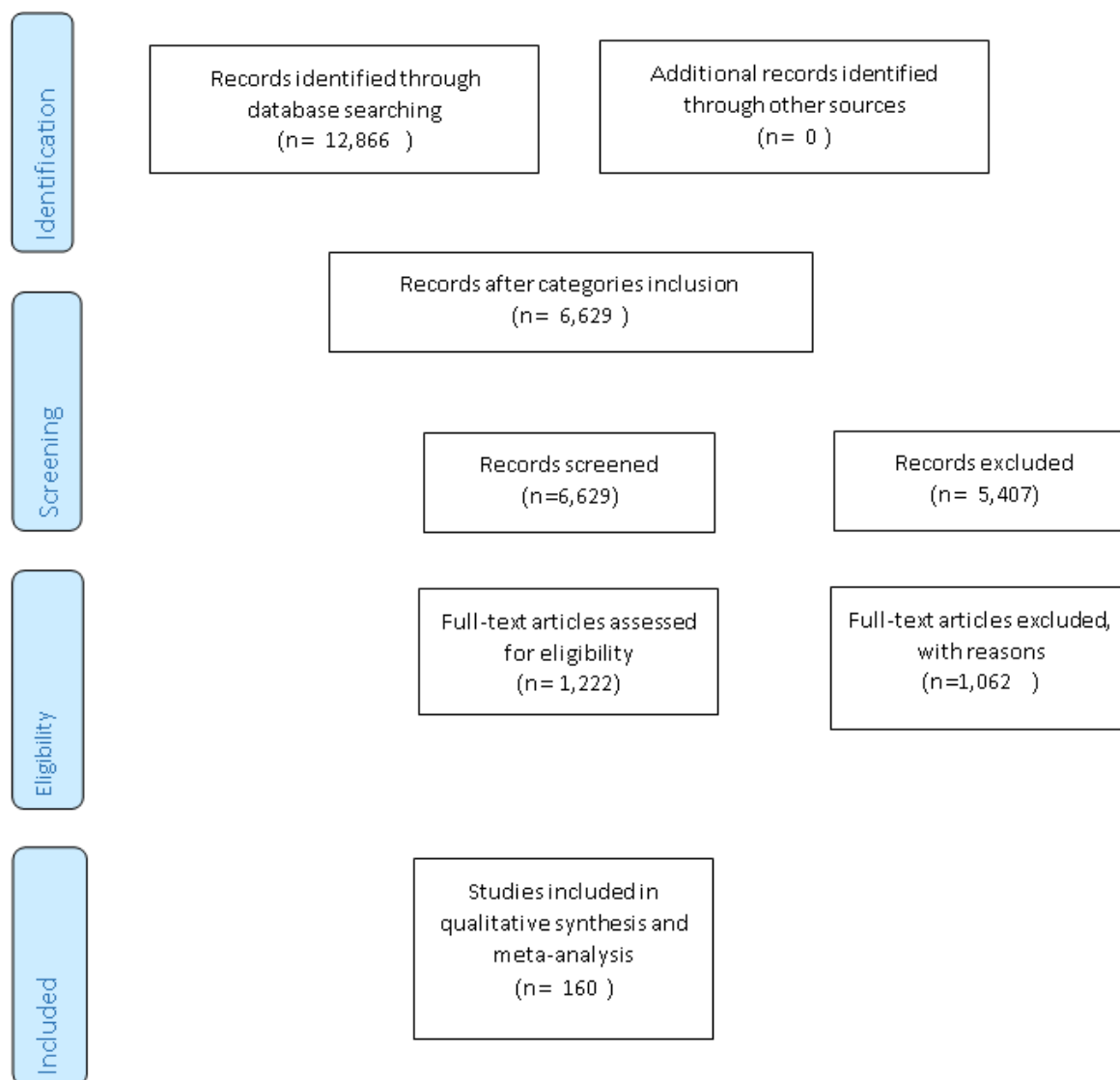

Source: This study.

Figure 1: The PRISMA flow diagram (adapted from Liberati *et al.*, 2009).

Meta-analysis

The focus of this section is to present the steps in undertaking our meta-analysis. The first step is deciding upon the scope of the review in terms of outcomes that will be included. The scope of our illustrative review is to analyze the prediction accuracy comparison between PM and other forecasting models. The purpose here is to randomly examine studies in which the outcome is to compare the forecast accuracy between prediction markets and well-known methods such as polls and experts. Based on this specific criteria, 24 studies have been considered to perform the meta-analysis.

Effect sizes

Once the studies have been extracted, the second step is to find and calculate a statistic, namely “Effect Estimate” (or effect size) that provides an estimate of the comparison effect for each study (Fritz *et al.*, 2012). Given the fact that the set of studies included in our review all assessed the same outcome which is the forecast accuracy of Prediction markets but used different methodologies, settings and population sizes we consider the accuracy ratio or winning ratio as our effect estimate and random effect model as our analysis model. The random effects model can be presented mathematically using the equation of Wang and Griswold (2016):

$$r_i = r_i' + \theta_i + \varepsilon_i \tag{1}$$

where r_i , the study effect estimate (Accuracy ratio in our case), is equal to the average comparison effect (r_i') plus a random term θ , which denotes methodological and setting specificities of study i , and a term ε , which represents error in estimating and calculating the study’s true effect.

The accuracy ratio for Prediction markets or alternative forecast methods is adapted from the approach of Khoshelham (2011):

$$Accuracy\ ratio = r = E_w/E_T \tag{2}$$

An approximate standard error of the accuracy ratio of a particular study i is given by:

$$SE_i = \sqrt{\frac{1}{E_w} + \frac{1}{E_A}} \tag{3}$$

In case, the standard deviation or variance are provided we calculate the standard error as follows:

$$SE_i = \frac{\sigma}{\sqrt{n}} \tag{4}$$

Where E_w is the average number of events won or correctly predicted events in average, E_A average number of events not predicted by prediction markets systems or correctly predicted by alternative forecast methods and E_T total number of predictions. σ is the standard deviation and n the sample size.

In most cases, the accuracy ratio is provided in the included studies. Otherwise, we compute this ratio based on the method and information available. For instance, if studies used Mean average error (MAE) or Brier score, we follow Tung *et al.* (2011) to calculate the accuracy ratio.

$$Accuracy = 1-MAE = 1-Brier\ score \tag{5}$$

Table 1 presents the information about the included studies as well as methods used. A detailed information about how we compute the effect estimate of those studies can be found in Appendix.

Meta-analytic effect estimate

At this stage, we selected a meta-analytic effect estimate to synthesize the effect sizes across the studies:

$$\Phi = \frac{\sum \omega_i r_i}{\sum \omega_i} = \frac{\omega_1 r_1 + \omega_2 r_2 + \dots + \omega_n r_n}{\omega_1 + \omega_2 + \dots + \omega_n} \tag{6}$$

Φ is the meta-analytic estimate of all studies; r_i is the study effect estimate (accuracy ratio) of study i ; ω_i is the weight of a particular study i .

The weight can be derived by applying inverse-variance weighting method (Marin-Martinez and Sanchez-Meca, 2010):

$$\omega_i = \frac{1}{SE_i^2} \tag{7}$$

The standard error of the meta-analytic effect estimate is used to provides a measure of the precision surrounding the meta-analytic effect estimate (Borenstein *et al.*, 2011). It is calculated as the square root of the reciprocal of the sum of the weights:

$$SE(\Phi) = \sqrt{\frac{1}{\sum \omega_i}} \tag{8}$$

The 95% confidence interval (CI) for the effect estimate would be computed as

$$Lower\ Limit = r_i - 1.96 \times SE_i(r_i)$$

$$Upper\ Limit = r_i + 1.96 \times SE_i(r_i)$$

Finally, the Z-value could be computed using:

$$Z = \frac{\Phi}{SE(\Phi)} \tag{9}$$

and the two-tailed p-value by: $p = 2[1 - \mathcal{N}(|Z|)]$ Where \mathcal{N} is the standard normal cumulative distribution function.

Table 1: Considerations on methodologies and data used by studies on Meta-analysis

Study	Data and methodology			Considerations
	<i>E_w</i>	<i>SD</i>	<i>n</i>	
<i>Atanasov et al. 2017</i>	na	Provided	Provided	<i>Authors used Brier score to compute the forecast accuracy. We only consider results from Experiment 1.</i>
<i>Berg et al. 2008</i>	Provided	n.a.	n.a.	<i>Binomial tests are used for the relative accuracy of the market.</i>
<i>Bohm and Sonneggard 1999</i>	Estimated*	Estimated*	Provided	<i>Authors used time series data to investigate the performance of the market. Here we only consider the YES outcome predicted by the market from 11/11 to 12/11</i>
<i>Brüggelambert 2004</i>	n.a.	Estimated*	Provided	<i>Mean absolute error (MAE) is considered by the authors to report the political market accuracy. We only consider the results for GEM 94 which is the largest market assed by their study.</i>
<i>Chen et al. 2003</i>	n.a.	Provided	Provided	<i>This paper proposed a relative performance (Kullback-Leibler measures). We only consider the results from Excerpt 1a.</i>
<i>Cowgill and Zitzewitz 2015</i>	n.a.	Provided	Provided	<i>We only consider results from Markets versus experts for Google.</i>
<i>Dana et al. 2019</i>	n.a.	Provided	Provided	<i>We consider the Brier scores for prices and beliefs presented in this study.</i>
<i>Graefe 2019</i>	n.a.	Estimated*	Provided	<i>This study uses the mean absolute error (MAE) to review the accuracy of four methods to forecast German federal elections. We consider combined markets and combined polls for our research.</i>
<i>Karniouchina 2011</i>	n.a.	Estimated*	Provided	<i>This study considered Virtual Stock Markets to assess the forecast of movie HSX forecasts</i>
<i>Leigh and Wolfers 2006</i>	Provided	Provided	Estimate d*	<i>We used an average of predicted probability of Howard victory for Prediction markets and Polls.</i>
<i>Li et al. 2016</i>	Provided	n.a.	Provided	<i>The authors studied a prediction market system to forecast infectious diseases in Taiwan</i>
<i>Matzler et al. 2013</i>	n.a.	Estimated*	Provided	<i>This research used MAE to test whether online consumer communities. Here, we consider race skis which has the lowest MAE.</i>
<i>Polgreen et al. 2007</i>	n.a.	Estimated*	Provided	<i>This research used prediction markets to tracking and forecasting emerging infectious diseases such as SARS. We consider results for 0 Weeks in advance.</i>
<i>Prokesch et al. 2015</i>	n.a.	Estimated*	Estimate d*	<i>Authors introduced an electronic combination of a prediction market and Delphi methodology. We consider MAPE for Prediction market on April+May+June.</i>
<i>Rieg and Schoder 2010</i>	Provided	Estimated*	Provided	<i>This experimental study compared forecast accuracy between prediction markets and a simple survey. We only consider the results from Simplified Prediction Market Design and Survey 1 which have the lowest variance.</i>
<i>Rothschild 2015</i>	n.a.	Provided	Provided	<i>This research paper combined the forecasts of victory with a probit of the inverse normal of their probabilities. Here we consider the coefficients for the probability of victory for Prediction markets.</i>
<i>Slamka et al. 2012</i>	n.a.	Provided	Provided	<i>This study conceptually and empirically compares the forecasting accuracy of Second-Generation prediction markets (G2). Here we consider Mean absolute errors across all topics.</i>
<i>Song et al. 2007</i>	Provided	n.a.	n.a.	<i>This paper compares the forecasts of the outcomes of NFL games made by statistical models, experts and markets. Here, we consider the proportion of game winners that were correctly predicted by markets and Experts.</i>
<i>Spann and Skiera 2003</i>	Provided	n.a.	n.a.	<i>We consider the Mean Absolute Percentage Error (MAPE) for HSX enhanced model.</i>
<i>Spann and Skiera 2009</i>	Provided	n.a.	n.a.	<i>This article compares the forecast accuracy of different methods, namely prediction markets, tipsters and betting odds,</i>
<i>Teschner et al. 2011</i>	Estimated*	n.a.	n.a.	<i>This paper design a market for economic derivatives that aggregates macro-economic information. We only consider results from Exports section</i>
<i>Tung et al. 2011</i>	Provided	Estimated*	Provided	<i>This paper devises a methodology to compare the accuracy of prediction markets and polls for Taiwan elections. We only consider the results for 2008 presidential election.</i>
<i>Tung et al. 2015</i>	Provided	n.a.	n.a.	<i>The author designed and built the Epidemic Prediction Markets (EPM) system.</i>
<i>Van Bruggen et al. 2010</i>	n.a.	Provided	Provided	<i>This paper used the mean absolute percentage error (MAPE) to scrutinize the forecast accuracy.</i>

Provided: means that the study directly mentioned this statistic; *Estimated**: We use information and data provided by the study to calculate the statistic; *n.a.*: non-available data. *E_w*: correctly predicted events by the Prediction market systems; *SD*: Standard deviation; *n*: number of participants.

Source: This study.

Heterogeneity

It is important to consider to what extent the results of studies are consistent. In our present research, we only consider statistical test which are chi-squared (χ^2 , or Chi2) test and I2 statistic to identify heterogeneity. It assesses whether observed differences in results are compatible with chance alone. A large chi-squared statistic relative to its degree of freedom provides evidence of heterogeneity of intervention effects (Higgins *et al.*, 2003).

$$\chi^2 = \sum \frac{(O - E)^2}{E} \quad (10)$$

Where O is the observed value in a study, E is its expected value

In addition to chi-squared, I^2 statistic describes the percentage of the total variability in effect estimates that is due to heterogeneity rather than within study variation. A value of 0% indicates no observed heterogeneity, and larger values show increasing heterogeneity. A value below 50% is often considered as moderate heterogeneity in a random effect model. Following Higgins and Thompson (2002), this statistic can be written as:

$$I^2 = \left(\frac{Q - df}{Q} \right) \times 100 \quad (11)$$

where Q is the chi-squared statistic and df (Number studies – 1) is its degrees of freedom.

Forest plot

To take all the relevant studies asking the same question, identify a common statistic in said papers and then to displays them on a certain way, we used RevMan 5, a software developed by Cochrane Collaboration. Forest plot is extracted to present the analysis of our study. Forest plot compare directly what the studies show and the quality of that result all in one place. The forest plot horizontal axis represents the accuracy ratio (relative statistic) the studies being profiled show while the vertical line is known as the “line of null effect” where there is no accuracy difference between Prediction markets and other alternative forecast methods. A point estimate of the study result represented by a red box. The bigger the box, the more important is the size of the study. Moreover, a horizontal line representing the 95% confidence intervals of the study result, with each end of the line representing the boundaries of the confidence interval.

RESULTS AND DISCUSSIONS

Prediction markets trends

Table 2 represents study of databases as well as journals/publishers for the review. The database that most commonly featured papers in Prediction markets is Elsevier containing 51 articles accounted for 32% of academic works published in journals such as European Journal of Operational Research, Journal of Banking & Finance, Decision Support Systems, Journal of Business Research, Journal of Forecasting and Business Horizons.

Databases such as Springer International Publishing and the Institute for Operations Research and the Management Sciences (INFORMS) account for 18% of academic publication. Springer International publishing 15 articles (9%) in journal such as Economic Theory, Information Systems Frontiers; Group Decision and Negotiation; Information Systems Frontiers while INFORMS publishing 14 articles (9%) in journal like Information Systems Research, Management science, Marketing Science, Operations Research and Decision Analysis. In addition, Institute of Electrical and Electronics Engineers (IEEE) published a total of 12 articles (7%) in IEEE Transactions on Engineering Management and International conferences such as International Workshop on Database and Expert Systems Applications; International Conference on Information Management, Innovation Management and Industrial Engineering; SICE Annual Conference.

Results also show that 21.88% Journals considered for the analysis have A* ranking in ABDC. And 43.75% of Journals considered here for analysis have A ranking in ABDC. A* and A Journals such as Journal of the Association for Information Systems, Decision Support Systems, Management science and others from different disciplines have been considered to provide an interdisciplinary approach to the study. Hence, it appears that top journals (A* and A ranking) are the preferred outcome for Prediction markets.

Table 2: Classification of academic works on prediction markets

<i>Database</i>	<i>ABDC ranking</i>	<i>Journal/Publisher</i>	<i>#</i>
Academica SINICA	n.a.	Journal of Information Science and Engineering	1
American Economic Association	A*	Journal of Economic Perspectives	2
Association for Computing Machinery	n.a.	ACM Transactions on Intelligent Systems and Technology	1
Association for Information Systems (AIS)	A*	Journal of the Association for Information Systems	1
Cambridge University Press	n.a.	Political Analysis; Political Science & Politics	2
Columbia Law Review Association	n.a.	The Columbia Science and Technology Law Review	1
Editura ASE	n.a.	Amfiteatru Economic Journal	1
Elsevier	A*	European Journal of Operational Research; Journal of Banking & Finance; Decision Support Systems; Energy Economics	11
	A	Finance Research Letters; International Journal of Accounting Information Systems; Technological Forecasting and Social Change; Economic Letters; International Journal of Forecasting; International Journal of Medical Informatics; Journal of Business Research; Journal of Forecasting	36
	B	Business Horizons	2
	n.a.	Physica A-Statistical Mechanics and its Applications; Electoral Studies	2
Emerald	A	Internet Research	2
	C	Foresight	3
Euromoney Institutional Investor	n.a.	The Journal of Investing	1
Google Scholar	n.a.	IGI Global	1
Harvard Business Publishing	A	Harvard Business Review	1
IEEE	A	IEEE Transactions on Engineering Management	1
	n.a.	International Workshop on Database and Expert Systems Applications; Conference on Technologies and Applications of Artificial Intelligence; Hawaii International Conference on System Sciences; IEEE International Conference on Innovations in Intelligent Systems and Applications; IEEE/WIC/ACM International Conferences on Web Intelligence and Intelligent Agent Technology; International Conference on Computers & Industrial Engineering; International Conference on Information Management, Innovation Management and Industrial Engineering; SICE Annual Conference; IEEE Intelligent Systems; IEEE Access	11
Inderscience	n.a.	International Journal of Electronic Business	1
INFORMS	A*	Information Systems Research; Management science; Marketing Science; Operations Research	11
	A	Decision Analysis	3
International Institute of Applied Informatics	n.a.	International Congress on Advanced Applied Informatics	1
MIT Press	A	MIT Sloan Management Review	1
Oxford University Press	A*	Journal of Consumer Research; Review of Economic Studies	3
	n.a.	Economic Journal; Public Opinion Quarterly; Clinical Infectious Diseases	4
Poznan School of Logistics	n.a.	LogForum	1
Sage Publications	A	California Management Review; Strategic Organization	3
	n.a.	Simulation & Gaming; Social Science Computer Review	2
Society for Judgment and Decision Making	A	Judgment and Decision Making	2
Southern Economic Association	n.a.	Southern Economics	1
Springer	n.a.	International Joint Conference on e-Business and Telecommunications	1
Springer Heidelberg	n.a.	Review of Economic Design	1
Springer International Publishing	A*	Economic Theory	1
	A	Information Systems Frontiers; Group Decision and Negotiation; Information Systems Frontiers	9
	B	Computational Economics; Information Systems and e-Business Management	2
	C	Ethics and Information Technology	1
Springer Nature	A	Electronic Markets	2
	n.a.	BMC Public Health	1
Taylor & Francis Online	A*	European Journal of Information Systems; Journal of Management Information Systems	3
	A	Applied Economics; Australian Journal of Political Science; International Journal of Electronic Commerce; Quantitative Finance	5
Taylor and Francis	n.a.	Journal of Political Science Education; Social Epistemology	2
University of Buckingham Press	B	The Journal of Prediction Markets	9
University of Minnesota Press	A*	MIS Quarterly	2
Washington University School of Law	n.a.	Washington University Law Review	1
Wiley-Blackwell Publishing	A*	Journal of Product Innovation Management	2
	A	Journal of Economic Surveys; R&D Management; Scandinavian Journal of Economics; The Economic Record	4
World Scientific Publishing Co.	A*	New Mathematics and Natural Computation	1
Total			160

Source: This study.

Prediction market application

Table 3 shows the classification of the studies according to prediction markets (PM) application. PM can be divided into two groups: internal use PMS and general public usage.

Internal use PMS

By internal use, we mean application of Prediction Markets not intended for the general public usage but specifically built for trading within companies or organizations. In the business world, prediction markets systems such as Satoshi, Dice230, BitBet and Iowa Electronic Markets Google IPO Markets have been already established internally to trade on strategically important objectives or key performance indicators, such as input prices, sales and project completion dates (Wolfram 2015; Teschner and Gimpel 2018; Chen *et al.* 2003; Othman and Sandholm 2013; Brito *et al.* 2014). Wolfram (2019) demonstrated that with clearly mandated goodwill from the top, Prediction markets can succeed as a forecasting methodology for companies. Berg *et al.* (2009) analyzing prediction markets systems intended to predict the post-IPO value of Google found that the markets were relatively accurate far in advance of the IPO.

General public usage PMS

Prediction Markets are also applied outside companies and organizations in areas such as politics, sport and entertainment industry, economic forecasting and healthcare sector.

- Politics

Research using markets for the sole purpose of aggregating beliefs regarding a future event was first developed at the University of Iowa in 1988. Commonly named as Iowa Electronic Markets (IEM), this prediction market system was built to forecast US presidential and state elections (Berg & Rietz, 2003; Berg *et al.*, 2008; Erikson & Wlezien, 2008; Graefe *et al.* 2014; Khan & Lieli 2018). Later, IEM-like platforms were used to run political stock markets on elections in Australia (Leigh & Wolfers, 2006), Germany (Brüggelambert, 2004), Sweden (Bohm & Sonnegard, 1999) and in Taiwan (Lin *et al.*, 2013; Tung *et al.*, 2011). Interesting fact about those systems is that forecasts derived from PM trading prices have been more accurate than their natural benchmark, namely polls, although traders exhibit biases (Atanasov *et al.*, 2017; Dana *et al.*, 2019). Moreover, trading prices react extremely quickly to new information (Berg & Rietz, 2019).

- Sport and entertainment industry

Servan-Schreiber *et al.* (2004) showed how prediction markets are widely used in sports and entertainment. These markets focus on forecasting the outcome of sports games and events such as baseball, soccer, football, hockey, basketball, tennis, and horse racing. Betfair.com, the World Sports Exchange, NewsFutures and TradeSports are among the most popular prediction market systems used in that field. Prediction Markets are even applied in the movie industry to predict box-office results (Sripawatakul & Sutivong, 2010). Two popular examples are the Hollywood Stock Exchange (HSX) and CMXX.com, prediction market where traders forecast box office success of movies. Results on show that these markets are considered as accurate predictions as experts (Blume *et al.*, 2010; Brown & Yang, 2019; Strumbelj 2014; Boulu-Reshef *et al.* 2016). In accordance with the efficient market hypothesis game events are quickly resulting in changes of trading prices.

- Economic forecasting

Another interesting field of PM application is the prediction of economic data such as retail sales, GDP, international trade balance, and the growth in payrolls. For this purpose, a market called “Economic Derivatives 20” was launched in 2002. A first analysis shows that the expectations reflected in trading prices are similar to survey based predictions (Kloker *et al.*, 2018; Teschner *et al.* 2011). Teschner *et al.* (2015) showed that those PMS can quickly incorporate new information, are largely efficient, and are impervious to manipulation. Also, they can be used to both uncover the economic model behind forecasts, as well as test existing economic models.

- Healthcare sector

Works related to the use of Prediction markets in the healthcare sector have also been reported in the literature. In 2007, Polgreen, Nelson and Neumann proposed a prediction market –the Iowa Influenza Market (IIM)– for tracking and forecasting emerging infectious diseases, such as severe acute respiratory syndrome and avian influenza, by aggregating expert opinion (Polgreen *et al.*, 2007). Later, Tung, Chou and Lin built a successful Epidemic Prediction Market System (EPMS) in Taiwan in 2010. But unlike the IIM, the Taiwan EPMS shown a superior performance in terms of duration, space, the number of diseases, and the method of trading transaction (Li *et al.*, 2016).

Forecast accuracy

Underneath the included studies are two statistics: heterogeneity and overall effect. The heterogeneity tests aim to determine if there are variations between the included studies. The Chi-squared statistic $\chi^2 = 42.90$ with a p-value of 0.007 translating presence of heterogeneity among our studies. The degree of heterogeneity is given by I2 test which is $46\% < 50\%$. That indicates a moderate and acceptable level of heterogeneity. Therefore, we conclude that there is an inferential reason to conduct further analysis.

Table 3: Main application of prediction markets

Purpose	System	Focus	Industry or area	Relevant literature
Internal use PMS	Hewlett-Packard, Corporate prediction market (CPM), Mechanical Turk; Gates Hillman prediction market (GHPM); Satoshi, Dice230 and BitBet; Iowa Electronic Markets Google IPO Markets	<ul style="list-style-type: none"> • Project management • Idea generation • Product development 	Business area	Wolfram 2015; Wolfram 2019; Teschner and Gimpel 2018; Chen <i>et al.</i> 2003; Othman and Sandholm 2013; Brito <i>et al.</i> 2014; Berg <i>et al.</i> 2009; Matzler <i>et al.</i> 2013; Gruca <i>et al.</i> 2003; O'Leary 2013; Karniouchina 2011; Spann and Skiera 2003
General public usage PMS	Iowa Electronic Markets (IEM); xFuture; PredictIt Kavanaugh Market, PKM; G1 and G2 markets; PollyVote; New York betting markets, Wall Street betting market; Centrebet; Foresight software; POSGI prediction market; PredictIt; Swedish EU-Referendum Political Stock Market	Political stock markets on elections	Political arena	Slamka <i>et al.</i> 2012; Brüggelambert 2004; Berg and Rietz 2003; Berg <i>et al.</i> 2008; Erikson and Wlezien 2012; Graefe <i>et al.</i> 2014; Jones 2008; Khan and Lieli 2018; Kou and Sobel 2004; Brown <i>et al.</i> 2019; Rothschild 2015; Rothschild and Sethi 2016; Strijbis and Arnesen 2019; Lin <i>et al.</i> 2013; Tai <i>et al.</i> 2019; Tung <i>et al.</i> 2011; Graefe 2019; Rhode and Strumpf 2004; Williams and Reade 2016; Berg and Chambers 2019; Groeger 2016; Bohm and Sonnégard 1999; Leigh and Wolfers 2006; LaComb <i>et al.</i> 2007; Jumadinova and Dasgupta 2015; Wolfers and Zitzewitz 2004; Vaughan Williams <i>et al.</i> 2019; Reade and Williams 2019
	<ul style="list-style-type: none"> • Betfair.com, Sports Exchange, PIM Sports, STOCER; NewsFutures and TradeSport • Hollywood Stock Exchange (HSX) and CMXX.com; IEM Movie Box Office Market; TradeSports.com; NewsFutures.com; FreeMarket; Intrade, Betfair 	<ul style="list-style-type: none"> • Sports games • Success of movies 	Sport and entertainment industry	Servan-Schreiber <i>et al.</i> 2004; Sripawatakul and Sutivong 2010; Sung <i>et al.</i> 2019; Blume <i>et al.</i> 2010; Brown and Yang 2019; Strumbelj 2014; Boulu-Reshef <i>et al.</i> 2016; Vlastakis <i>et al.</i> 2009; Restocchi <i>et al.</i> 2019; McHugh and Jackson 2012; Song <i>et al.</i> 2007
	Economic Derivatives 20; Continuous artificial prediction market (c-APM); Economic Indicator Exchange (EIX); Clean Energy Exchange	Retail sales, GDP, international trade balance, etc.	Economic forecasting	Jahedpari <i>et al.</i> 2017; Kloker <i>et al.</i> 2018; Teschner <i>et al.</i> 2015; Teschner <i>et al.</i> 2011; Borison and Hamm 2010; Gangur and Plevny 2014
	Iowa Influenza Market (IIM); Epidemic Prediction Market System (EPMS); Flu Market; Taipex	Emerging infectious diseases	Healthcare sector	Polgreen <i>et al.</i> 2007; Li <i>et al.</i> 2015; Li <i>et al.</i> 2016; Tung <i>et al.</i> 2015; Wang <i>et al.</i> 2006
<ul style="list-style-type: none"> • IBET • Hyperledger Composer • Prediction markets on terrorism (PMsoT) 	<ul style="list-style-type: none"> • Blockchain • Social network • Terrorism 	Others	Carvalho 2020; Dubin 2019; Qiu <i>et al.</i> 2013; Qiu and Kumar 2017; Weijers and Richardson 2014	

Source: This study.

Next to the list of the included studies, are results on the studies effect estimates. In our study, the effect estimate measured were the Accuracy ratio. In addition, we presented the standard error (SE), the study weight as well as the 95% confidence intervals (CIs). The study weight is the power of the study. Studies such as Slamka *et al.* (2012) with a weight of 20.0% and an effect size of 0.82 (95% CI: [0.81, 0.83]), Cowgill and Zitzewitz (2015) with a weight of 17.2% and an effect size of 0.82 (95% CI: [0.80, 0.84]), Van Bruggen *et al.* (2010) with a weight of 15.4% and an effect size of 0.81 (95% CI: [0.79, 0.84]) and Dana *et al.* (2019) with a weight of 14.2% and an effect size of 0.79 (95% CI: [0.76, 0.82]) have lower variation, i.e. tighter 95% CIs, smaller horizontal line but bigger red box, higher weight and more influence on the overall effect. A possible explanation is that those studies mostly focus on the transparency of the payoff mechanisms while analyzing the accuracy of the different forecast methods. In their experimental design, the authors explain how the participants saw the same information when making trades. This may open onto a heightened level of trust in the process and the experience as a whole. In addition, those studies carefully recruited forecasters from professional societies, research centers and so on based on effective participant recruitment techniques. Those techniques lead to participant's retention as well as the enhancement of the whole experience. For example, authors reported that participants competed for social rewards, including a place on the leaderboard and the chance to join an elite group of "super-forecasters".

The smaller the study, the wider the horizontal line and smaller the red box representing the point estimate because 95% confidence intervals will be much bigger. This means, studies such as Teschner *et al.* (2011) with a weight of 0.0% and an effect size of 0.58 (95% CI: [-0.57, 1.73]) and Brüggelambert (2004) with a weight of 0.1% and an effect size of 0.44 (95% CI: [-0.44, 1.32]) cross the line of null effect and therefore do not illustrate statistically significant results. Based on the effect size of those studies, the markets were relatively less accurate than other forecast methods. However, we cannot conclude anything given the fact that the tests reveal insignificant results. One possible reason is that those studies do not provide the accuracy ratio or appropriate data and information to compute those statistics. In this case, we calculate the effect estimate based on results of those studies. In addition, both papers highlighted the dissemination of information from informed insiders to less informed participants in German markets. That probably the reason why they couldn't disclose more information about accuracy and efficiency of the markets.

Studies such as Li *et al.* (2016) and Tung *et al.* (2015) share the same weight (2.30%) and same effect size of 0.65 (95% CI: [0.52, 0.77]). Like Polgreen *et al.* (2007) who proposed a prediction markets to track and forecast emerging infectious diseases, Li *et al.* (2016) and Tung *et al.* (2015) scrutinized the first Epidemic Prediction Markets (EPM) system in Taiwan showing that markets have a better prediction capability than historical average data in depicting the trend of epidemic diseases. They found that EPM was 65% more accurate than the traditional baseline of historical average for the target week. Similarly, studies like Bohm and Sonnégard (1999) and Matzler *et al.* (2013) present the same weight (0.30%) and the same effect size of 0.97 (95% CI: [0.60, 1.35]). Bohm and Sonnégard (1999) demonstrated how Prediction markets worked well in predicting the outcome of the Swedish EU referendum while Matzler *et al.* (2013) shows that prediction markets work well in forecasting new products using online communities.

Studies such as Tung *et al.* (2011) and Spann and Skiera (2003) have the same weight (0.40%) but different effect size. With an effect size of 0.65 (95% CI: [0.52, 0.77]), Tung *et al.* (2011) devised a methodology to compare the accuracy of prediction markets and polls and shown that the prediction markets outperform the opinion polls in various indices of accuracy while Spann and Skiera (2003) whose effect size is 0.72 (95% CI: [0.38, 1.05]), show rather encouraging results for the applicability of Virtual Stock Markets (VSM) for business forecasting purposes. Similarly, Karniouchina (2011) having an effect size of 0.96 (95% CI: [0.78, 1.13]) share the same weight of 1.20% with Song *et al.* (2007) with an effect size of 0.66 (95% CI: [0.48, 0.83]). Karniouchina (2011) finds a good predictability of the Hollywood Stock Exchange (HSX) that is an online prediction market allowing people to trade movie and movie star stocks while Song *et al.* (2007) analyzing the betting line predictions found that prediction market was substantially superior to both experts and systems in predicting game winners.

Studies such as Leigh and Wolfers (2006), Graefe (2019), Berg *et al.* (2008), Chen *et al.* (2003) and Rieg and Schoder (2010) also have a weight lower than 2%. A possible explanation is based on study outcomes and experiment settings. Indeed, Leigh and Wolfers (2006) studying the efficacy of econometric models, public opinion polls and prediction markets in light of the 2004 Australian election found that markets provide a useful forecasting performance (0.68; 95% CI: [0.24, 1.11]) but data suggest a more reasonable degree of volatility (SD=0.221). Hence, the lower weight in our analysis. Graefe (2019) also reviewed the accuracy of multiple forecast methods in the context of elections. He found that on average across both elections, polls and prediction markets were both highly accurate (0.98; 95% CI: [0.73, 1.23]) but admitted that the accuracy of individual forecasts did not correlate across elections. Berg *et al.* (2008) with an effect size of 0.71 (95% CI: [0.57, 0.86]) compared prediction markets to polls over past presidential elections and found that the market significantly outperforms the polls in every election when forecasting more than 100 days in advance.

Chen *et al.* (2003) got an effect size of 0.85 (95% CI: [0.65, 1.04]) by introducing a novel methodology for predicting future outcomes that uses small numbers of individuals participating. Experiments show that this nonlinear aggregation mechanism vastly outperforms both the imperfect market and the best of the participants. Rieg and Schoder (2010) following Chen *et al.* (2003) designed a small-scale laboratory experiment and found no differences in accuracy when comparing markets and opinion polls. The experiments demonstrated that it is possible to gain highly accurate forecasts (0.86; 95% CI: [0.58, 1.14]) with a relatively small number of participants taking part continuously.

Finally, black diamond at the bottom of the forest plot shows the meta-analytic effect estimate Φ when all the individual studies are combined together and averaged. (Fig. 3). The meta-analytic effect estimate which is 0.79 (95% CI: [0.77, 0.81]) indicates that on average prediction markets is 79% more accurate than alternative forecast methods based on included studies. The overall effect, Z testing the overall effect significance when taking all the included studies together has a p-value lower than 0.00001, which indicates a very significant result.

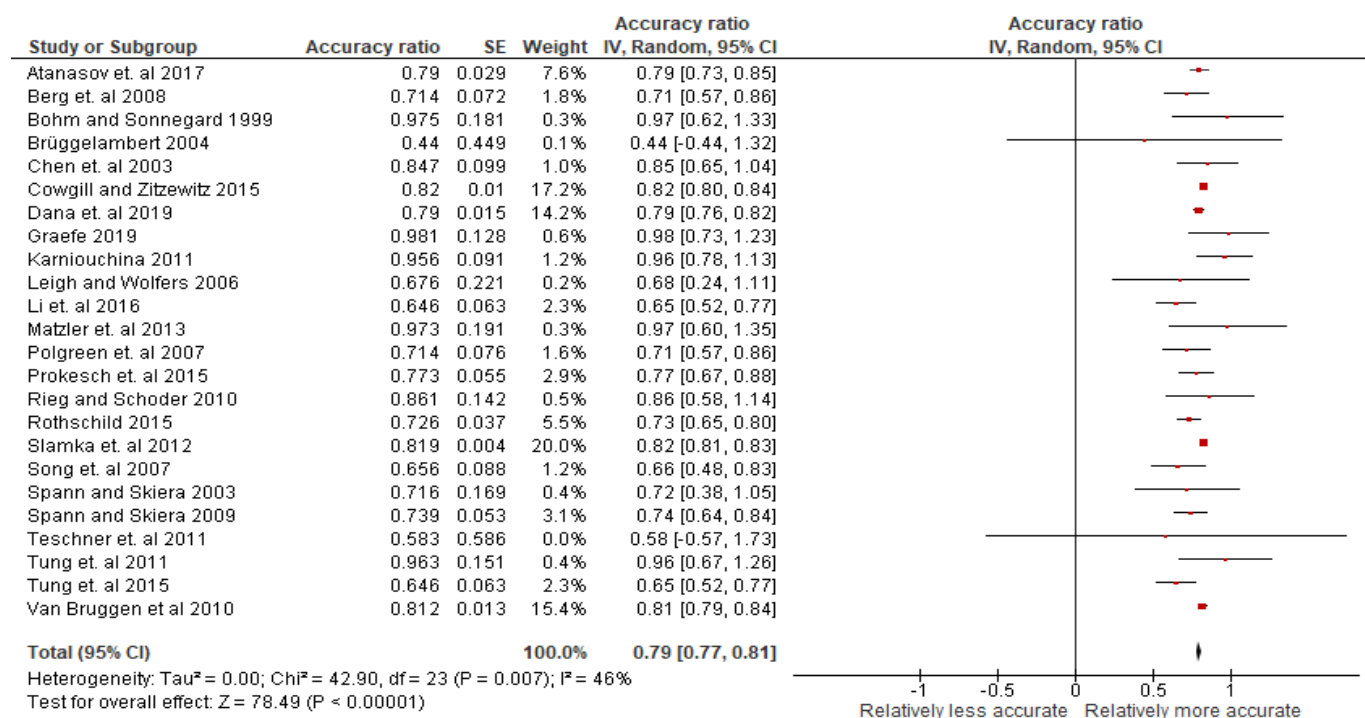

Accuracy ratio Effect size) were calculated from random effects meta-analysis with inverse variance weighting (see Methodology, Meta-analysis). SE: Standard deviation; df: degree of freedom

Source: This study.

Figure 2: Effect sizes from studies comparing PMs forecast accuracy versus alternative prediction methods.

RESULTS AND DISCUSSIONS

Conclusions

By systematically review previous academics works related to Prediction Markets (PM), this paper found that PM can be classified internal use PM and general public usage. The first group refers to Prediction Market systems not intended for the general public usage but specifically built for trading within companies or organizations while General public usage PM applied outside companies and organizations in areas such as politics, sport and entertainment industry, economic forecasting and healthcare sector. Moreover, our paper shows that more than 64% of papers are published in top journals such as Journal of the Association for Information Systems, Decision Support Systems, Management science. It has been considered to provide an interdisciplinary approach to the study.

In terms of forecast accuracy, we conducted a meta-analysis. The test indicates a moderate and acceptable level of heterogeneity. Furthermore, we found that. Studies such as Slamka *et al.* (2012), Cowgill and Zitzewitz (2015), Van Bruggen *et al.* (2010) and Dana *et al.* (2019) have smaller horizontal line but bigger red box and more influence on the overall effect. A possible explanation is that those studies mostly focus on the transparency of the payoff mechanisms while analyzing the accuracy of the different forecast methods. In addition, we found that studies using small numbers of participants with inappropriate experiment settings share the lowest weight of the analysis.

Finally, our meta-analytic effect estimate indicates that on average prediction markets is 79% more accurate than alternative forecast methods based on included studies. The overall effect, Z testing the overall effect significance when taking all the included studies together has a p-value lower than 0.00001, which indicates a very significant result.

Limitations and future research

Although we have shown important contribution to the literature, it's crucial to notice some limitations that future research can consider. First, the compilation of 160 publications following the reporting checklist of the PRISMA framework was systematic, but our assessment of the inclusion criteria and studies quality is based on our subjective judgment. Therefore, some relevant articles may not have been included in this review.

Future work can extend this framework by considering other databases such as Scopus, Jstor and so on to perform systematic review on Prediction markets. In addition, subsequent research can consider different inclusion and exclusion criteria and other journal ranking lists like social sciences citation index (SSCI) or Association of Business Schools (ABS). Future researchers may also consider to review themes by describing in more comprehensive way the methodology, and types of data collected.

A second limitation is regarding the language and research trends. In the future, research reviews may include academic works published in languages other than English, opening new collaboration opportunities for joint research with Chinese, Russian, French, or Indian academics for example. An analysis of themes across the years may show the research trends and identify application areas. Additionally, an analysis of the co-authorship networks and citation counts may also be useful for the justification of studies on Prediction markets systems.

Lastly, we restricted our meta-analytic model in considering articles comparing forecast accuracy of prediction markets versus other forecast methods. Subsequent research can enlarge the total outcome by considering other variables. Moreover, we estimated some important statistics such as effect size based on available information and assumption. For the sake of transparency, we have disclosed all the computations we have made in this research in Appendix. Future papers can consider other models and effect estimates such as Standardized Mean Difference (SMD). These limitations can provide future research avenues and can step on the contributions established by this paper regarding a systematic review and meta-analysis on Prediction markets

REFERENCES

- [1] Aliakbari, E., & McKittrick, R. (2018). Information aggregation in a prediction market for climate outcomes. *Energy Economics*, 74, 97-106.
- [2] Atanasov, P., Rescober, P., Stone, E., Swift, S. A., Servan-Schreiber, E., Tetlock, P., Ungar, L. & Mellers, B. (2017). Distilling the wisdom of crowds: Prediction markets vs. prediction polls. *Management Science*, 63(3), 691-706.
- [3] Berg, J. E., & Rietz, T. A. (2019). Longshots, overconfidence and efficiency on the Iowa Electronic Market. *International Journal of Forecasting*, 35(1), 271-287.
- [4] Bothos, E., Apostolou, D., & Mentzas, G. (2009). Collective intelligence for idea management with Internet-based information aggregation markets. *Internet Research*, 19(1), 26-41.
- [5] Brito, J., Shadab, H., & Castillo, A. (2014). Bitcoin financial regulation: Securities, derivatives, prediction markets, and gambling. *Columbia Science and Technology Law Review*, 16(1), 144-221.
- [6] Brown, A., & Yang, F. (2019). The wisdom of large and small crowds: Evidence from repeated natural experiments in sports betting. *International Journal of Forecasting*, 35(1), 288-296.
- [7] Brown, A., Reade, J. J., & Williams, L. V. (2019). When are prediction market prices most informative? *International Journal of Forecasting*, 35(1), 420-428.
- [8] Brüggelambert, G. (2004). Information and efficiency in political stock markets: using computerized markets to predict election results. *Applied Economics*, 36(7), 753-768.
- [9] Buckley, P. (2016). Harnessing the wisdom of crowds: Decision spaces for prediction markets. *Business Horizons*, 59(1), 85-94.
- [10] Buckley, P., & O'Brien, F. (2017). The effect of malicious manipulations on prediction market accuracy. *Information Systems Frontiers*, 19(3), 611-623.
- [11] Carvalho, A. (2016). An overview of applications of proper scoring rules. *Decision Analysis*, 13(4), 223-242.
- [12] Carvalho, A. (2017). On a participation structure that ensures representative prices in prediction markets. *Decision Support Systems*, 104, 13-25.
- [13] Carvalho, A. (2020). A permissioned blockchain-based implementation of LMSR prediction markets. *Decision Support Systems*, 130, 113228.
- [14] Chen, K. Y., Fine, L. R., & Huberman, B. A. (2003). Predicting the future. *Information Systems Frontiers*, 5(1), 47-61.
- [15] Chen, M. K., Ingersoll Jr, J. E., & Kaplan, E. H. (2008). Modeling a presidential prediction market. *Management Science*, 54(8), 1381-1394.
- [16] Chen, W., Li, X., & Zeng, D. D. (2017). Modelling Fixed Odds Betting for Future Event Prediction. *MIS Quarterly*, 41(2), 645-665.
- [17] Chie, B. T., & Chen, S. H. (2013, December). On the Prediction Accuracy of Prediction Markets: Would the Spatial Distribution of Information Matter? In 2013 Conference on Technologies and Applications of Artificial Intelligence (pp. 367-369). IEEE.
- [18] Chie, B. T., & Chen, S. H. (2015). The use of knowledge in prediction markets: How much of them need he know? *Journal of Information Science and Engineering*, 31(1), 1-22.
- [19] Cowgill, B., & Zitzewitz, E. (2015). Corporate prediction markets: Evidence from google, ford, and firm x. *The Review of Economic Studies*, 82(4), 1309-1341.
- [20] Czwayda, L., Kosacka-Olejnik, M., Kudelska, I., Kostrzewski, M., Sethanan, K., & Pitakaso, R. (2019). Application of prediction markets phenomenon as decision support instrument in vehicle recycling sector. *LogForum*, 15(2), 265-278.
- [21] Dana, J., Atanasov, P., Tetlock, P., & Mellers, B. (2019). Are markets more accurate than polls? The surprising informational value of "just asking". *Judgment and Decision Making*, 14(2), 135-147.
- [22] Davenport, T. H., & Harris, J. G. (2009). The prediction lover's handbook. *MIT Sloan Management Review*, 50(2), 32-34.
- [23] Deck, C., & Porter, D. (2013). Prediction markets in the laboratory. *Journal of Economic Surveys*, 27(3), 589-603.

- [24] Decker, C., Welpel, I. M., & Ankenbrand, B. H. (2011). How to motivate people to put their money where their mouth is: What makes employees participate in electronic prediction markets? *Technological Forecasting and Social Change*, 78(6), 1002-1015.
- [25] Di, C., Dimitrov, S., & He, Q. M. (2019). Incentive compatibility in prediction markets: Costly actions and external incentives. *International Journal of Forecasting*, 35(1), 351-370.
- [26] Dixon, M. J., & Pope, P. F. (2004). The value of statistical forecasts in the UK association football betting market. *International Journal of Forecasting*, 20(4), 697-711.
- [27] Dubin, J. D. (2019). Blockchain prediction markets: Where they came from, why they matter & how to regulate those involved. *Washington University Law Review*, 97(2), 575-607.
- [28] Easton, S., & Uylangco, K. (2010). Forecasting outcomes in tennis matches using within-match betting markets. *International Journal of Forecasting*, 26(3), 564-575.
- [29] Erikson, R. S., & Wlezien, C. (2008). Are political markets really superior to polls as election predictors? *Public Opinion Quarterly*, 72(2), 190-215.
- [30] Felin, T., & Zenger, T. R. (2011). Information aggregation, matching and radical market-hierarchy hybrids: Implications for the theory of the firm. *Strategic Organization*, 9(2), 163-173.
- [31] Flostrand, A. (2017). Finding the future: Crowdsourcing versus the Delphi technique. *Business Horizons*, 60(2), 229-236.
- [32] Gangur, M., & Plevný, M. (2014). Tools for consumer rights protection in the prediction of electronic virtual market and technological changes. *Amfiteatru Economic Journal*, 16(36), 578-593.
- [33] Gioia, D. A., & Pitre, E. (1990). Multiparadigm perspectives on theory building. *Academy of Management Review*, 15(4), 584-602.
- [34] Glass, G. V. (1976). Primary, secondary, and meta-analysis of research. *Educational Researcher*, 5(10), 3-8.
- [35] Goodwin, P., & Wright, G. (2010). The limits of forecasting methods in anticipating rare events. *Technological Forecasting and Social Change*, 77(3), 355-368.
- [36] Graefe, A. (2019). Accuracy of German federal election forecasts, 2013 & 2017. *International Journal of Forecasting*, 35(3), 868-877.
- [37] Graefe, A., & Armstrong, J. S. (2011). Comparing face-to-face meetings, nominal groups, Delphi and prediction markets on an estimation task. *International Journal of Forecasting*, 27(1), 183-195.
- [38] Graefe, A., Armstrong, J. S., Jones Jr, R. J., & Cuzán, A. G. (2014). Combining forecasts: An application to elections. *International Journal of Forecasting*, 30(1), 43-54.
- [39] Grant, A., Johnstone, D., & Kwon, O. K. (2019). The cost of capital in a prediction market. *International Journal of Forecasting*, 35(1), 313-320.
- [40] Gruca, T. S., Berg, J., & Cipriano, M. (2003). The effect of electronic markets on forecasts of new product success. *Information Systems Frontiers*, 5(1), 95-105.
- [41] Guo, Z., Fang, F., & Whinston, A. B. (2006). Supply chain information sharing in a macro prediction market. *Decision Support Systems*, 42(3), 1944-1958.
- [42] Hanson, R. (2003). Combinatorial information market design. *Information Systems Frontiers*, 5(1), 107-119.
- [43] Hanson, R. (2007). Logarithmic markets coring rules for modular combinatorial information aggregation. *The Journal of Prediction Markets*, 1(1), 3-15.
- [44] Healy, P. J., Linardi, S., Lowery, J. R., & Ledyard, J. O. (2010). Prediction markets: Alternative mechanisms for complex environments with few traders. *Management Science*, 56(11), 1977-1996.
- [45] Higgins, J. P., & Thompson, S. G. (2002). Quantifying heterogeneity in a meta-analysis. *Statistics in Medicine*, 21(11), 1539-1558.
- [46] Higgins, J. P., Thompson, S. G., Deeks, J. J., & Altman, D. G. (2003). Measuring inconsistency in meta-analyses. *BMJ*, 327(7414), 557-560. doi: 10.1136/bmj.327.7414.557
- [47] Hill, S., & Ready-Campbell, N. (2011). Expert stock picker: the wisdom of (experts in) crowds. *International Journal of Electronic Commerce*, 15(3), 73-102.
- [48] Hvattum, L. M., & Arntzen, H. (2010). Using ELO ratings for match result prediction in association football. *International Journal of Forecasting*, 26(3), 460-470.
- [49] Jahedpari, F., Rahwan, T., Hashemi, S., Michalak, T. P., De Vos, M., Padget, J., & Woon, W. L. (2017). Online prediction via continuous artificial prediction markets. *IEEE Intelligent Systems*, 32(1), 61-68.
- [50] Jian, L., & Sami, R. (2012). Aggregation and manipulation in prediction markets: effects of trading mechanism and information distribution. *Management Science*, 58(1), 123-140.
- [51] Jones Jr, R. J. (2008). The state of presidential election forecasting: The 2004 experience. *International Journal of Forecasting*, 24(2), 310-321.
- [52] Jumadinova, J., & Dasgupta, P. (2015). Automated pricing in a multiagent prediction market using a partially observable stochastic game. *ACM Transactions on Intelligent Systems and Technology (TIST)*, 6(4), 1-25.
- [53] Karimi, M., & Dimitrov, S. (2018). On the Road to Making Science of "Art": Risk Bias in Market Scoring Rules. *Decision Analysis*, 15(2), 72-89.
- [54] Karniouchina, E. V. (2011). Are virtual markets efficient predictors of new product success? The case of the Hollywood stock exchange. *Journal of Product Innovation Management*, 28(4), 470-484.
- [55] Kerr, N. L., & Tindale, R. S. (2011). Group-based forecasting? A social psychological analysis. *International Journal of Forecasting*, 27(1), 14-40.

- [56] Khan, U., & Lieli, R. P. (2018). Information flow between prediction markets, polls and media: Evidence from the 2008 presidential primaries. *International Journal of Forecasting*, 34(4), 696-710.
- [57] Klein, M., & Garcia, A. C. B. (2015). High-speed idea filtering with the bag of lemons. *Decision Support Systems*, 78, 39-50.
- [58] Kloker, S., Straub, T., & Weinhardt, C. (2019). Moderators for partition dependence in prediction markets. *Group Decision and Negotiation*, 28(4), 723-756.
- [59] LaComb, C. A., Barnett, J. A., & Pan, Q. (2007). The imagination market. *Information Systems Frontiers*, 9(2-3), 245-256.
- [60] Leigh, A., & Wolfers, J. (2006). Competing approaches to forecasting elections: Economic models, opinion polling and prediction markets. *Economic Record*, 82(258), 325-340.
- [61] Li, E. Y., Tung, C. Y., & Chang, S. H. (2015). User adoption of wisdom of crowd: Usage and performance of prediction market system. *International Journal of Electronic Business*, 12(2), 185-214.
- [62] Li, E. Y., Tung, C. Y., & Chang, S. H. (2016). The wisdom of crowds in action: Forecasting epidemic diseases with a web-based prediction market system. *International Journal of Medical Informatics*, 92, 35-43.
- [63] Manski, C. F. (2006). Interpreting the predictions of prediction markets. *Economics Letters*, 91(3), 425-429.
- [64] Marín-Martínez, F., & Sánchez-Meca, J. (2010). Weighting by inverse variance or by sample size in random-effects meta-analysis. *Educational and Psychological Measurement*, 70(1), 56-73.
- [65] Matzler, K., Grabher, C., Huber, J., & Füller, J. (2013). Predicting new product success with prediction markets in online communities. *R&D Management*, 43(5), 420-432.
- [66] Metcalf, L., Askay, D. A., & Rosenberg, L. B. (2019). Keeping humans in the loop: pooling knowledge through artificial swarm intelligence to improve business decision making. *California Management Review*, 61(4), 84-109.
- [67] Miller, N., Resnick, P., & Zeckhauser, R. (2005). Eliciting informative feedback: The peer-prediction method. *Management Science*, 51(9), 1359-1373. <https://doi.org/10.1287/mnsc.1050.0379>
- [68] Mizuyama, H., & Maeda, Y. (2010, July). A prediction market system using SIPS and generalized LMSR for collective-knowledge-based demand forecasting. In *The 40th International Conference on Computers & Industrial Engineering* (pp. 1-6). IEEE.
- [69] Mizuyama, H., Yamaguchi, S., & Sato, M. (2019). A prediction market-based gamified approach to enhance knowledge sharing in organizations. *Simulation & Gaming*, 50(5), 572-597.
- [70] Moher, D., Liberati, A., Tetzlaff, J., Altman, D. G., & Prisma Group. (2009). Preferred reporting items for systematic reviews and meta-analyses: The PRISMA statement. *PLoS med*, 6(7), e1000097.
- [71] O'Leary, D. E. (2015). User participation in a corporate prediction market. *Decision Support Systems*, 78, 28-38.
- [72] Oliven, K., & Rietz, T. A. (2004). Suckers are born but markets are made: Individual rationality, arbitrage, and market efficiency on an electronic futures market. *Management Science*, 50(3), 336-351.
- [73] Öörni, A. (2003). Consumer search in electronic markets: an experimental analysis of travel services. *European Journal of Information Systems*, 12(1), 30-40.
- [74] Othman, A., & Sandholm, T. (2013). The gates Hillman prediction market. *Review of Economic Design*, 17(2), 95-128.
- [75] Page, L., & Clemen, R. T. (2013). Do prediction markets produce well-calibrated probability forecasts? *The Economic Journal*, 123(568), 491-513.
- [76] Palak, R., & Nguyen, N. T. (2017, July). Prediction markets as a vital part of collective intelligence. In *2017 IEEE International Conference on INnovations in Intelligent SysTems and Applications (INISTA)* (pp. 137-142). IEEE.
- [77] Pandey, P., & Snekenes, E. A. (2014, September). Applicability of prediction markets in information security risk management. In *2014 25th International Workshop on Database and Expert Systems Applications* (pp. 296-300). IEEE.
- [78] Pham, M. T., Lee, L., & Stephen, A. T. (2012). Feeling the future: The emotional oracle effect. *Journal of Consumer Research*, 39(3), 461-477.
- [79] Plott, C. R. (2000). Markets as information gathering tools. *Southern Economic Journal*, 67(1), 2-15.
- [80] Polgreen, P. M., Nelson, F. D., Neumann, G. R., & Weinstein, R. A. (2007). Use of prediction markets to forecast infectious disease activity. *Clinical Infectious Diseases*, 44(2), 272-279.
- [81] Qiu, L., & Kumar, S. (2017). Understanding voluntary knowledge provision and content contribution through a social-media-based prediction market: A field experiment. *Information Systems Research*, 28(3), 529-546.
- [82] Qiu, L., Rui, H., & Whinston, A. (2013). Social network-embedded prediction markets: The effects of information acquisition and communication on predictions. *Decision Support Systems*, 55(4), 978-987.
- [83] Rainer Jr, R. K., & Miller, M. D. (2005). Examining differences across journal rankings. *Communications of the ACM*, 48(2), 91-94.
- [84] Ray, R. (2012). Managing Financial Risk Via Prediction Markets. *The Journal of Investing*, 21(2), 76-80.
- [85] Reade, J. J., & Williams, L. V. (2019). Polls to probabilities: Comparing prediction markets and opinion polls. *International Journal of Forecasting*, 35(1), 336-350.
- [86] Rhode, P. W., & Strumpf, K. S. (2004). Historical presidential betting markets. *Journal of Economic Perspectives*, 18(2), 127-141.
- [87] Ridley, D. (2012). *The Literature Review: A Step-By-Step Guide for Students*. Sage Publishing.
- [88] Rothschild, D. (2009). Forecasting elections: Comparing prediction markets, polls, and their biases. *Public Opinion Quarterly*, 73(5), 895-916.
- [89] Rothschild, D. (2015). Combining forecasts for elections: Accurate, relevant, and timely. *International Journal of Forecasting*, 31(3), 952-964.

- [90] Rothschild, D. M., & Sethi, R. (2016). Trading strategies and market microstructure: Evidence from a prediction market. *The Journal of Prediction Markets*, 10(1), 1-29.
- [91] Sato, T., & Fukuta, N. (2018, July). A Simulation-Based Interactive Tuning Approach for the Parameter Optimization of Privacy-Preserved Prediction Markets. In *2018 7th International Congress on Advanced Applied Informatics (IIAI-AAI)* (pp. 600-605). IEEE.
- [92] Servan-Schreiber, E., Wolfers, J., Pennock, D. M., & Galebach, B. (2004). Prediction markets: Does money matter? *Electronic Markets*, 14(3), 243-251.
- [93] Seshadri, A. K. (2015). Nonconvex equilibrium prices in prediction markets. *Decision Analysis*, 12(1), 1-14.
- [94] Sethi, R., & Vaughan, J. W. (2016). Belief aggregation with automated market makers. *Computational Economics*, 48(1), 155-178.
- [95] Simmons, J. P., Nelson, L. D., Galak, J., & Frederick, S. (2011). Intuitive biases in choice versus estimation: Implications for the wisdom of crowds. *Journal of Consumer Research*, 38(1), 1-15.
- [96] Sjöberg, L. (2009). Are all crowds equally wise? A comparison of political election forecasts by experts and the public. *Journal of Forecasting*, 28(1), 1-18.
- [97] Slamka, C., Jank, W., & Skiera, B. (2012). Second-generation prediction markets for information aggregation: A comparison of payoff mechanisms. *Journal of Forecasting*, 31(6), 469-489.
- [98] Slamka, C., Skiera, B., & Spann, M. (2012). Prediction market performance and market liquidity: A comparison of automated market makers. *IEEE Transactions on Engineering Management*, 60(1), 169-185.
- [99] Song, C., Boulier, B. L., & Stekler, H. O. (2007). The comparative accuracy of judgmental and model forecasts of American football games. *International Journal of Forecasting*, 23(3), 405-413.
- [100] Soukhoroukova, A., Spann, M., & Skiera, B. (2012). Sourcing, filtering, and evaluating new product ideas: An empirical exploration of the performance of idea markets. *Journal of Product Innovation Management*, 29(1), 100-112.
- [101] Spann, M., & Skiera, B. (2003). Internet-based virtual stock markets for business forecasting. *Management Science*, 49(10), 1310-1326.
- [102] Spann, M., & Skiera, B. (2009). Sports forecasting: A comparison of the forecast accuracy of prediction markets, betting odds and tipsters. *Journal of Forecasting*, 28(1), 55-72.
- [103] Sperb, L. F. C., Sung, M. C., Johnson, J. E., & Ma, T. (2019). Keeping a weather eye on prediction markets: The influence of environmental conditions on forecasting accuracy. *International Journal of Forecasting*, 35(1), 321-335.
- [104] Sripawatakul, P., & Sutivong, D. (2010, November). Analysis of trading duration in pari-mutuel prediction markets. In *2010 3rd International Conference on Information Management, Innovation Management and Industrial Engineering* (Vol. 3, pp. 141-144). IEEE.
- [105] Strijbis, O., & Arnesen, S. (2019). Explaining variance in the accuracy of prediction markets. *International Journal of Forecasting*, 35(1), 408-419.
- [106] Štrumbelj, E. (2014). On determining probability forecasts from betting odds. *International Journal of Forecasting*, 30(4), 934-943.
- [107] Sung, M. C., McDonald, D. C., Johnson, J. E., Tai, C. C., & Cheah, E. T. (2019). Improving prediction market forecasts by detecting and correcting possible over-reaction to price movements. *European Journal of Operational Research*, 272(1), 389-405.
- [108] Tai, C. C., Lin, H. W., Chie, B. T., & Tung, C. Y. (2019). Predicting the failures of prediction markets: A procedure of decision making using classification models. *International Journal of Forecasting*, 35(1), 297-312.
- [109] Tarnaud, R. (2019). Convergence within binary market scoring rules. *Economic Theory*, 68(4), 1017-1050.
- [110] Teschner, F., & Gimpel, H. (2018). Crowd labor markets as platform for group decision and negotiation research: A comparison to laboratory experiments. *Group Decision and Negotiation*, 27(2), 197-214.
- [111] Teschner, F., Kranz, T. T., & Weinhardt, C. (2015). The impact of customizable market interfaces on trading performance. *Electronic Markets*, 25(4), 325-334.
- [112] Teschner, F., Rothschild, D., & Gimpel, H. (2017). Manipulation in conditional decision markets. *Group Decision and Negotiation*, 26(5), 953-971.
- [113] Thicke, M. (2017). Prediction Markets for Science: Is the Cure Worse than the Disease? *Social Epistemology*, 31(5), 451-467.
- [114] Thompson, D. N. (2012). *Oracles: How prediction markets turn employees into visionaries*. Harvard Business Press.
- [115] Toriumi, F., & Ishii, K. (2011, September). Analyzing prediction market mechanism using artificial markets. In *SICE Annual Conference 2011* (pp. 509-513). IEEE.
- [116] Toubia, O. (2006). Idea generation, creativity, and incentives. *Marketing Science*, 25(5), 411-425.
- [117] Tumasjan, A., Sprenger, T. O., Sandner, P. G., & Welp, I. M. (2011). Election forecasts with Twitter: How 140 characters reflect the political landscape. *Social Science Computer Review*, 29(4), 402-418.
- [118] Tung, C. Y., Chou, T. C., & Lin, J. W. (2015). Using prediction markets of market scoring rule to forecast infectious diseases: A case study in Taiwan. *Infection*, 59(4,291), 23-199.
- [119] Tziralis, G., & Tsiopoulos, I. (2007). Prediction markets: An extended literature review. *The Journal of Prediction Markets*, 1(1), 75-91.
- [120] Van Bruggen, G. H., Spann, M., Lilien, G. L., & Skiera, B. (2010). Prediction markets as institutional forecasting support systems. *Decision Support Systems*, 49(4), 404-416.
- [121] Vaughan Williams, L., Sung, M., & Johnson, J. E. V. (2019). Prediction markets: Theory, evidence and applications. *International Journal of Forecasting*, 35(1), 266-270.

- [122] Vlastakis, N., Dotsis, G., & Markellos, R. N. (2009). How efficient is the European football betting market? Evidence from arbitrage and trading strategies. *Journal of Forecasting*, 28(5), 426-444.
- [123] Wang, S. C., Tseng, J. J., Li, S. P., & Chen, S. H. (2006). Prediction of bird flu A (H5N1) outbreaks in Taiwan by online auction: Experimental results. *New Mathematics and Natural Computation*, 2(03), 271-279.
- [124] Wang, W., & Griswold, M. E. (2016). Estimating overall exposure effects for the clustered and censored outcome using random effect Tobit regression models. *Statistics in Medicine*, 35(27), 4948-4960.
- [125] Weijers, D., & Richardson, J. (2014). Is the repugnance about betting on terrorist attacks misguided? *Ethics and Information Technology*, 16(3), 251-262.
- [126] Williams, L. V., & Reade, J. J. (2016). Forecasting elections. *Journal of Forecasting*, 35(4), 308-328.
- [127] Wolfers, J., & Leigh, A. (2002). Three tools for forecasting federal elections: Lessons from 2001. *Australian Journal of Political Science*, 37(2), 223-240.
- [128] Wolfers, J., & Zitzewitz, E. (2004). Prediction markets. *Journal of Economic Perspectives*, 18(2), 107-126.
- [129] Wolfram, T. (2019). Benefits and challenges of corporate prediction markets. *Foresight: The International Journal of Applied Forecasting*, 54, 29-36.
- [130] Yang, S., Li, T., & van Heck, E. (2015). Information transparency in prediction markets. *Decision Support Systems*, 78, 67-79.

Projecting the Community Pharmacy into Home Health Care: An IS Perspective

(Full Paper)

Alexandra Ângelo*, Miguel Torga Institute, Portugal, alexandraangelo@ismt.pt

João Barata, University of Coimbra, Centre for Informatics and Systems of the University of Coimbra,

Department of Informatics Engineering, Portugal, barata@dei.uc.pt

Ana Paula Melo Santos, Farmácia Dona Maria, Portugal, farmacia.donamaria@gmail.com

ABSTRACT

Community pharmacies deliver accessible and personalized health care to populations worldwide. Provision of medicine therapy is central to this business but the continuous interactions with clients in their homes is problematic. This paper models an ecosystem of wellness for community pharmacies and presents five generations of smart pharmaceutical care systems (SPCS) for home interventions. Our project follows the design science research paradigm and is supported in a literature review of 31 recent information systems papers. Two key challenges of Health 5.0 are addressed: digital medication management and sustainable medicine use. SPCS reveal potential to change the business model of community pharmacies. However, spanning the pharmacy boundaries with digital technologies requires (1) socio-technical strategies to differentiate their offer, (2) technologies tailored to the needs of each client, (3) collective intelligence production in medicine supply chains, and (4) humanized telecare.

Keywords: Smart Pharmaceutical Care, Community Pharmacy, Smart PillBox, Medicine Management, SPCS.

*Corresponding author

INTRODUCTION

Community (or retail) pharmacies are at the forefront of health care assistance to local population, thereby particularly relevant to address the proximity needs of an ageing society. The foundational mission of medicine provision is now integrated in a diversified product portfolio that includes medical devices and advice in nutrition, or fitness. Online interaction and smart products pave the way for pharmacist-driven smart health care, “to engage patients more proactively with their prescribed therapy using mobile communication and devices” (Gatwood, Hohmeier, & Brooks, 2019).

The “5.0” movement of human-centered development in industry (Bednar & Welch, 2020) is also transforming the vast health care sector. For example, exploiting the internet of things, cloud, mobile, autonomous robots, and artificial intelligence (AI) for personalized treatment (Javaid & Haleem, 2019). Technology serving human purposes and sustainable goals will be a priority for sociotechnical transformation (Bednar & Welch, 2020) and “Health 5.0” promises major advances in health data connectivity, machine and artificial intelligence integration, and ecosystems of wellness (QUT, 2018). However, community pharmacies are still in the early stages of digital transformation (Gatwood et al., 2019) and many customers are struggling to manage their medication. The work of Beuscart et al. (2019) supports the urgent need to extend pharmacy intervention to the home, particularly for some segments of the population facing “medication storage problems (21.7%), expired medications (40.7%), potentially inappropriate medications (15.0%), several different generic versions of the same drug (19.9%), and redundant medications (20.4%)” (Beuscart et al., 2019).

Physical devices such as electronic pillboxes appeared a few decades ago (e.g., Hayes et al. (2006)) and can be used to implement telecare (Karlsen, Haraldstad, Moe, & Thygesen, 2019). However, the vision embodying human-centered digitalization of pharmacies has many unanswered questions. For example, programmable smart pillboxes can send reminders and organize medication, but its capacity to be personalized to the needs of each patient is limited and its effectiveness vary (e.g., depending on the diseases, patient characteristics, type of medication). We highlight three related research opportunities revealed by Singh and Varshney (2020): *new theoretical models for IT-based reminders, integration of new emerging technologies (e.g., AI), and the potential of combining reminders with other solutions.*

How community pharmacies can go “beyond the reminder” (Gatwood et al., 2019) with physical-digital solutions to provide pharmaceutical care at home is the main challenge that we address in this paper. Two research questions are formulated: *RQ1: How recent Information Systems (IS) literature addresses the topic of smart pharmaceutical care?* and *RQ2: What types of IT-based medication management can project the community pharmacy intervention into home health care?* These questions inquire the knowledge base to understand “what is available” (Thuan, Drechsler, & Antunes, 2019) and the “way of framing” the inner world (internal structure) and the outer world (requirements and properties) of artefacts (Simon, 1996; Thuan et al., 2019) for the selected research context.

The rest of this paper is organized as follows. The next section explains our design science research (DSR). Afterwards, the results of a systematic literature review of 31 information systems publications are detailed. Subsequently, five types of smart

pharmaceutical care systems (SPCS) are modelled. The discussion follows, stating the limitations and future research opportunities. The paper closes with the main conclusions.

RESEARCH APPROACH

Our joint-research project with a community pharmacy follows design science research to produce a new model (Hevner, March, Park, & Ram, 2004). The pharmacy shareholders have recently invested in a private clinic and aim to create an ecosystem of wellness, projecting their sphere of influence into home health care.

Design science is a research approach that evolves in steps of (1) *problem formulation and motivation*, (2) *define objectives of the solution*, (3) *design and development*, (4) *demonstration*, (5) *evaluation*, and (6) *communication* (Peffers, Tuunanen, Rothenberger, & Chatterjee, 2007). Our research entry point (Peffers et al., 2007) is the initial step of problem formulation and motivation, considering the novelty of the topic for community pharmacies and the lack of SPCS instantiations for home intervention in this context. Digital technologies give form to the pharmacy owners' ambitions, and they have heard about recent advances in smart pillboxes and medication reminders (Singh & Varshney, 2020; Solís, Cedillo, Parra, Guevara, & Ortiz, 2017). The pharmacists were interested in smart and connected devices (Porter & Heppelmann, 2015) able to (1) strengthen their bonds with the end users, (2) increase medication adherence, (3) support inventory planning, and (4) positively impact their customers' quality of life. According to the pharmacy owners, the replacement of traditional pillboxes (plastic recipients used for organizing medicines) by high-tech solutions with prices that can reach hundreds of dollars is unaffordable to many customers. Moreover, an app would be appealing, but still insufficient to enforce medicine safety (e.g., locks) and there are barriers to mHealth in many segments of the elderly population.

RQ1 aims to clarify the actors, goals, and tasks of smart pharmaceutical care. The most disruptive opportunities with Health 4.0 and Health 5.0 are still nascent and sociotechnical. Therefore, our search strategy pointed to recent literature in the field of information systems, not restricting journals or conferences. The research process is explained in Figure 1.

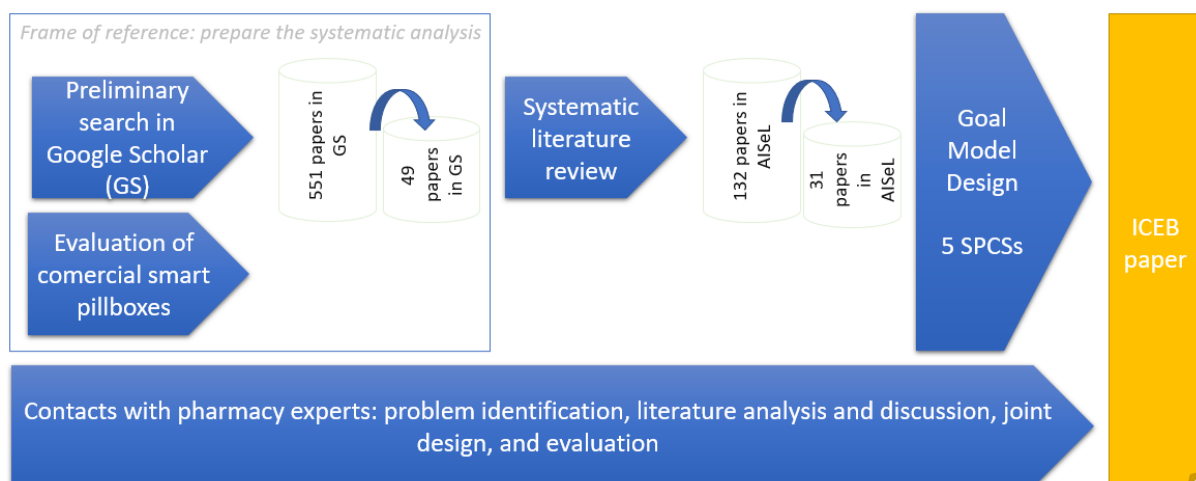

Source: This study.

Figure 1: DSR Research Process.

The first phase aimed to create a frame of reference. Google Scholar was selected due to its broad coverage. The keywords used were: ("*smart pillbox*" OR "*smart pill box*" OR "*pill dispenser*" OR "*medicine dispenser*") AND "*information system*" returning 153 results; "*reminders*" AND "*adherence*" AND ("*pill box*" OR "*pillbox*") AND "*information systems*", with 151 hits since 2015; "*smart pillbox*" OR "*smart pill dispenser*" OR "*automatic pill dispenser*" + *sensor* with 55 results in the past two years. We also included general terms such as "*smart pillbox*", checking the highest cited papers (>9 with 224 results). A total of 49 papers were evaluated by the team at this phase to identify relevant keywords, trends, and technologies available. Additionally, commercial solutions were checked by the research team to understand key features (e.g., alarms, mobile interfaces, medicine traceability). For example, Pria™ by Black & Decker, Philips Lifeline, Hero, or RxPense®. There are also solutions for reminders and organizers (e.g., MedQ) that can also include locks (e.g., Med-E-Lert™).

Subsequently, we conducted a systematic literature review (Webster & Watson, 2002) in AIS Electronic Library (AISeL), using the keywords (tuned in the previous round): *pillbox* OR "*medication adherence*" OR "*medicine adherence*" OR "*pill dispenser*" OR "*pill box*" OR "*medicine dispenser*" OR "*medication dispenser*" OR "*drug dispenser*" OR "*medicine reminder*" OR "*pill reminder*" OR "*medication reminder*" (132 results since 2015). AISeL was selected because it is one of the most important databases for the IS community, including top conferences and journals. Moreover, it facilitates full access to the sources. Finally, we also screened titles of papers published before 2015 to ensure that no critical topic was missing. Since our purpose was to identify the most recent contributions to the topic, we restrict the selection to papers (in conferences or journals) published in the past two years (2019 and 2020), and journal articles published since 2015. Other exclusion criteria were

papers restricted to the more technical details (e.g., specific portals), short papers, related work conducted by the same authors, or addressing different outcomes (e.g., research methods).

A total of 31 papers were selected for inclusion in the concept-centric review presented herein. After describing the problem and the input knowledge, we continue our DSR process (vom Brocke & Maedche, 2019) with the construction of SPCS models. Five types of *IT-based medication management* (used interchangeably with SPCS) for the unique context of community pharmacies are identified and modelled with i* (i-star) language (Yu, 1997). The i* language can be used for strategic reasoning but also to understand the needs of different actors, “*shifting focus from value exchange and creation to stakeholder goals, motivations, and intentions*” (Samavi, Yu, & Topaloglou, 2009). The i* language was considered accessible by our case pharmacy company to identify SPCS requirements.

SMART PHARMACEUTICAL CARE: INSIGHTS FROM THE IS FIELD

Models connecting people, data, and technology can assist decision making but it is essential to understand how “*can these models be developed to incorporate the needs of the patient, what works and what does not work for the patient, and how can the provider intervene effectively at a particular point in time given the history of care*” (Bardhan, Chen, & Karahanna, 2020). Pill dispenser technology is included in the extensive list of Mhealth tools connected to smartphones and sensors (Gerhardt, Breitschwerdt, & Thomas, 2018). Yet, it is necessary “*more research that focus on wearables and sensors, such as those in smart homes*” (Imre & Wass, 2019). The following subsections detail (overlapping) concepts of design, use, value, and market of “smarter” pharmaceutical care.

System Design

Multiple stakeholders must collaborate “*in ensuring that the e-health system fits the learning needs of the individual and satisfies the ethical standard of due care*”, but also in effective communication during self-care management, learning (Chiasson, Kelley, & Downey, 2015), and experience (Yang, Guo, Peng, Lai, & Luo, 2020). The work of Gao et al. (2019) presents questions that must be addressed by systems designers, for example, the roles of each entity, (multidimensional) integration, process adaptability, or usability. However, studies covering community pharmacies and IT-based collaboration are clearly insufficient.

Health 4.0 includes a plethora of technologies that can be integrated. Health 5.0 (QUT, 2018) turns the spotlight to human-machine relations and sustainability. For example, wearables can produce information valuable to the user (Behne et al., 2020). Yet, there are challenges in complex innovation processes involving multiple stakeholders, as revealed by a longitudinal study of medical dispensing robots (Aaen, 2019). The case includes nine municipalities and four companies, highlighting both technical (e.g., some errors can compromise the user’s confidence in the system) and social issues (e.g., mobilizing testers).

Other authors adopt a holistic stance in digital health design. The architecture for smart systems proposed by Strobel and Perl (2020), offers a starting point to the development of solutions in this field. A conceptual model for a data-driven solution in health care was tested by Burkhardt and Burkhardt (2020) using a scenario “*that integrates different data supporting the patient in his home environment. For example, it monitors the medication box, orders medicine, reports drug misuse, books doctor appointments or reports the health status*” (Burkhardt & Burkhardt, 2020). This home assistant scenario was envisioned by a health expert and medication availability, adherence, and monitoring are top priorities.

System Use

The work of Azad and King in hospital settings (e.g., Azad and King 2008) is frequently cited in workarounds research. Beerepoot et al. (2020) uncovered which workarounds are more likely to be accepted or rejected. Although their work does not address community pharmacies, it is probable that workarounds involving patients (e.g., pillbox user) or expert knowledge in complex decisions are more likely to be unacceptable, while some workarounds involving collaboration may be acceptable. The phenomena should be closely monitored, particularly in the cases of medication recording (Beerepoot, 2019).

Incentives to promote adherence to devices and digital platforms are essential. For example, using persuasive trigger messages (Sittig, Franklin, & Sittig, 2020). Moreover, physical materialities can be used to increase information reliability and it is possible to design reminders with different type of messages to reinforce patient adherence (X. Liu & Varshney, 2019).

Gamification can be explored to improve medication adherence (Schmidt-Kraepelin, Warsinsky, Thiebes, & Sunyaev, 2020). Other examples include personalization and fair information practices – originally proposed for personal health records (Gabel, Münster, Nüesch, & Gabel, 2019), that could be extended to nursing home scenarios. A recent study about the acceptance of health chatbots was conducted by Mesbah and Pumplun (2020), extending UTAUT2 with factors such as resistance to change, need for emotional support, technology anxiety, and privacy. The important role of users emotions is also confirmed by Savoli, Barki, and Pare (2020). These contributions can be adopted in pharmacy contexts where quality of life is a priority.

System Value

Karlsen et al. (2019) present an inspiring study about telecare affordances in home care services, ranging from simple personal alarms or reminders to more advanced medicine dispenser robots and external devices (e.g., cameras or door sensors). These authors conclude that “*the actualization process was strongly influenced by contextual factors, where anchoring and*

cooperation, competence and knowledge, and routines and follow-up were considered the most prominent factors” (Karlsen et al., 2019).

Reminders and motivational functions are two proven effective strategies to improve elderly health (N. Liu, Yin, Wongmaneroj, & Teo, 2020), preventing health problems, and reducing affluence to health care structures. Prevention is key, for example, in asthma treatments (Son, Flatley Brennan, & Zhou, 2020). Another example presented by Varshney and Singh (2020) shows the adoption of IT (mobile apps, devices, and sensors) for the prevention of opioid-based disorders.

Dobson et al. (2019) identified savings close to 50% if the hospital adopts enhanced inventory management practices, when comparing to the usual approach to automated dispensing systems. For home contexts, there are opportunities for ambient assisted living “that not only includes the latest base technological innovations but also responds to recognized user needs in a way that is easy to understand and based on a series of interconnected device-generated data” (Bozan & Berger, 2019). However, there is still a lack of medicine-centered studies integrating physical and digital materialities.

Information Value

Valuable data can be generated in electronic health processes, perhaps more visible in processes linking the pharmacy and the hospital (Xie, Palvia, & Vance, 2020), but pharmacies are also deeply intertwined with the industry, experts and carers (e.g., nursing homes).

Smart pharmaceutical care systems maximize its value when the information is bidirectional. On the one hand, smart devices can provide information to support the users (Bozan & Berger, 2019). On the other hand, information collected by the devices (or manually inputs in the case of apps) are important for health care supply chains. For example, to evaluate the service provided by nursing homes (e.g., efficiency, errors), the effect of medication, and anticipate medicine orders.

Pillbox information can reduce medication errors (Johnsen, Fruhling, & Fossum, 2016). Existing systems aiming to reduce inappropriate prescribing in polypharmacy contexts are advancing fast. However, collective intelligence (Marsh, Carroll, & Foggie, 2011) that is increasingly produced by humans and machines is not yet being employed in existing robot-dispensing systems, limiting the full potential for decision-support and sustainable use of medication in ecosystems of wellness.

Market Innovation

The combination of new electronic medicine dispensing and business model innovations is possible, but may fail if they are based in short term vision (Heikkilä, Bowman, & Heimo, 2019). Moreover, innovation in ecosystems of wellness is complex. A recent case study presented by Wainwright et al. (2020) describes telehealth care services adoption (including multiple electronic devices and medication dispensers). They conclude that additional work is necessary to fully understand the ecosystem involved (Wainwright et al., 2020). Public-private collaborations can create a broader digital infrastructure (Kempton & Bränden, 2020). However, when the process is initiated by a (small or medium) private community pharmacy, the support of public co-funded projects to explore value in technology and data seems to be appropriate.

There are five main assumptions that IS researchers must be aware when creating new systems that “*adapt to situations, perceive their environments, and interact with humans and other technologies*” (Schuetz & Venkatesh, 2020): “(1) the direction of the user- artifact relationship, (2) the artifact’s awareness of its environment, (3) functional transparency, (4) reliability, and (5) the user’s awareness of artifact use”. These authors present the example of reminders that benefit from adaptivity in different contexts, making them more effective in the future. However, a single smart device does not seem sufficient to ensure personalized pharmaceutical care in all contexts and address the goals of different stakeholders in ecosystems of wellness. Therefore, the next section distinguishes and models five smart pharmaceutical care systems, with different levels of connectivity.

MODELLING ECOSYSTEMS OF WELLNESS FOR COMMUNITY PHARMACIES

This section presents the models created by researchers and practitioners to project the case pharmacy into home health care.

The models are built with i* (Yu, 1997), originally proposed for requirements engineering. The key elements are (Yu, 1997): the actors (⊙), the goals (◻), the soft goals (◻) - differ from the former due to the lack of a precise classification, the tasks of that actor (◻), and the resources needed (SPCS versions). For the sake of simplicity, only the most relevant elements are shown, the soft goals are restricted to the society actor, and dependencies between actors are omitted.

Five SPCSs are modelled according to the literature findings described in the previous section and the strategy of the selected community pharmacy. The simplest SPCS is 100% digital: static web sites and/or SMS reminders (SPCS 1.0). It is also possible to find cases of pure physical devices (SPCS 2.0, no connectivity) for organizing the pills, providing alarms, or locks to increase safety. SPCS 3.0 are 100% digital systems with bidirectional interaction, for example, apps for monitoring medication adherence that are popular in the literature. SPCS 4.0 incorporates Industry 4.0 technologies and offers a combination of physical (smart pillboxes, smart watch) and digital (apps) layers. Finally, SPCS 5.0 envisions the next generation of human-centered solutions with smart home devices (e.g., smart cabinets), and digital capabilities to support societal goals (beyond interaction between patients and carers that is the usual scenario in SPCS 4.0).

The main actors identified in the smart pharmaceutical care systems are the community pharmacy (case company), the patient and the carers (e.g., nursing home context), the society, and the clinic (actor external to the pharmaceutical administration process but included in the desired ecosystem). Figures 2-4 describe the goals, soft goals (selected to represent societal needs), the tasks performed in home care scenarios, and the support that each type of SPCS – ranging from the simpler digital SPCS 1.0 with reminders to the more advanced and integrated devices in SPCS 5.0.

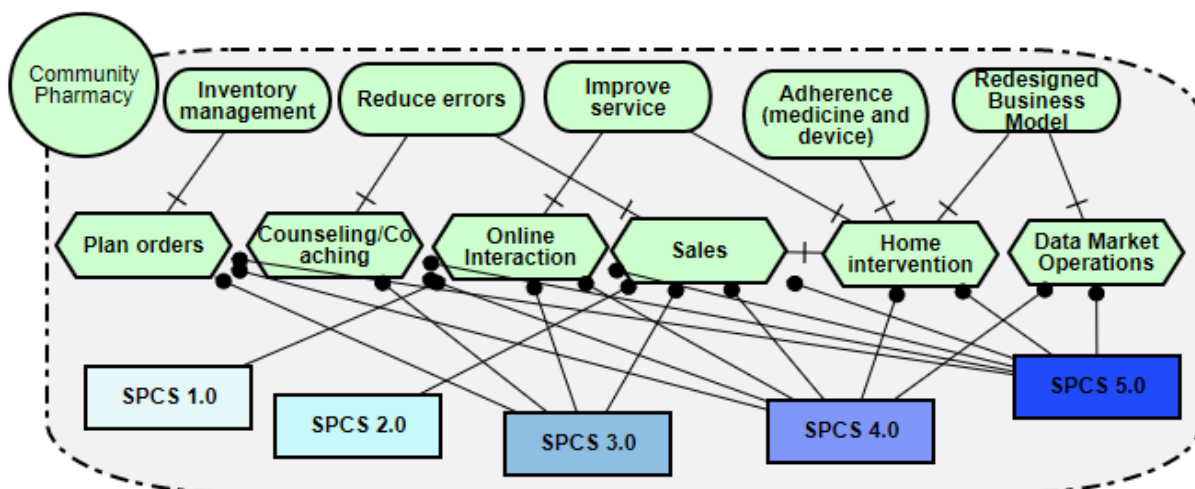

Source: This study.

Figure 2: Goal Model for SPCS Design: The Community Pharmacy.

The literature review indicates that important savings are possible with proper inventory management (Dobson et al., 2019) and that automatic pill dispensers can reduce errors (Johnsen et al., 2016). However, these goals are difficult to achieve with reminders (e.g., via SMS) or traditional pill boxes. The business value of SPCS 1.0 and 2.0 (resources on the bottom-left of Figure 2) is more visible in the case of direct sale: (1) reminders to assist their customers after purchasing medicines and (2) the incorporation of (physical) medicine dispensing devices increasing their product portfolio.

SPCS 3.0 (apps) adds more value to the internal processes of the community pharmacy (e.g., plan orders - the user can insert their needs via app) because bidirectional communication becomes possible. Some pharmacies are already exploring this type of SPCS (Davies, Collings, Fletcher, & Mujtaba, 2014), but only with the fourth and fifth generations the pharmacy can aspire to transform their business model with telecare. In fact, the lack of a physical layer in SPCS 3.0 also limits its potential to improve medication adherence, real-time monitoring of the medicine dispenser, and collecting data from nursing homes. The shift to “5.0” needs connectivity between the medicine dispensing device and other objects of the patient's environment.

According to one of the community pharmacy owners, existing medicine dispensing systems are not able to store large quantities of different medications, some of them occasionally used. Smart cabinets connected to the dispensing system can extend the value of the solution with inventory management (1) in the individual dispensing system and (2) in the patient environment. Moreover, SPC 5.0 could improve planning deliveries to nursing homes and monitoring if stock variations are explained by the individual dispensing devices (nursing homes need smart medicine dispensers for multiple patients), producing more data to prevent errors, improve service, and project redesigned home care services by community pharmacies. Figure 3 presents the patient (3-a) and carers (3-b) model (both models can be integrated for autonomous patients).

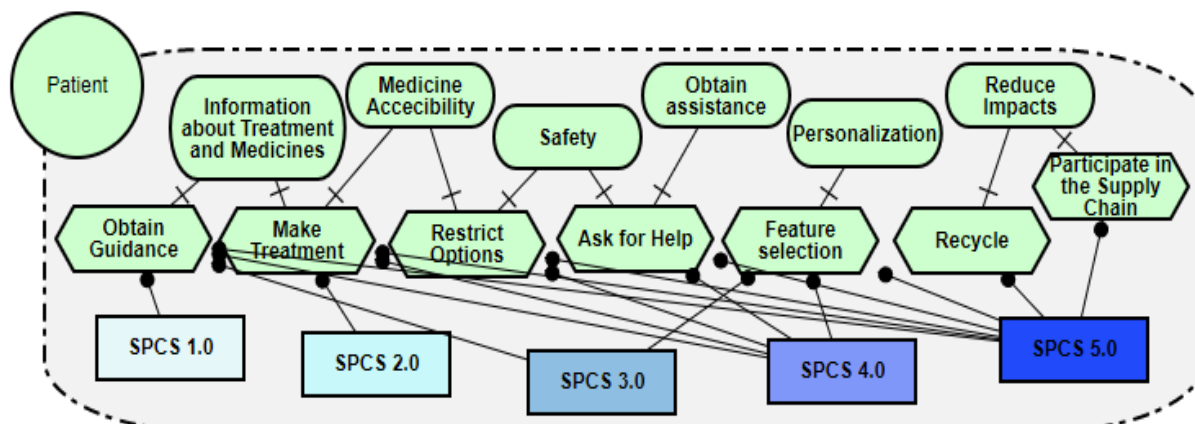

Source: This study.

Figure 3-a: Goal Model for SPCS Design: Patient.

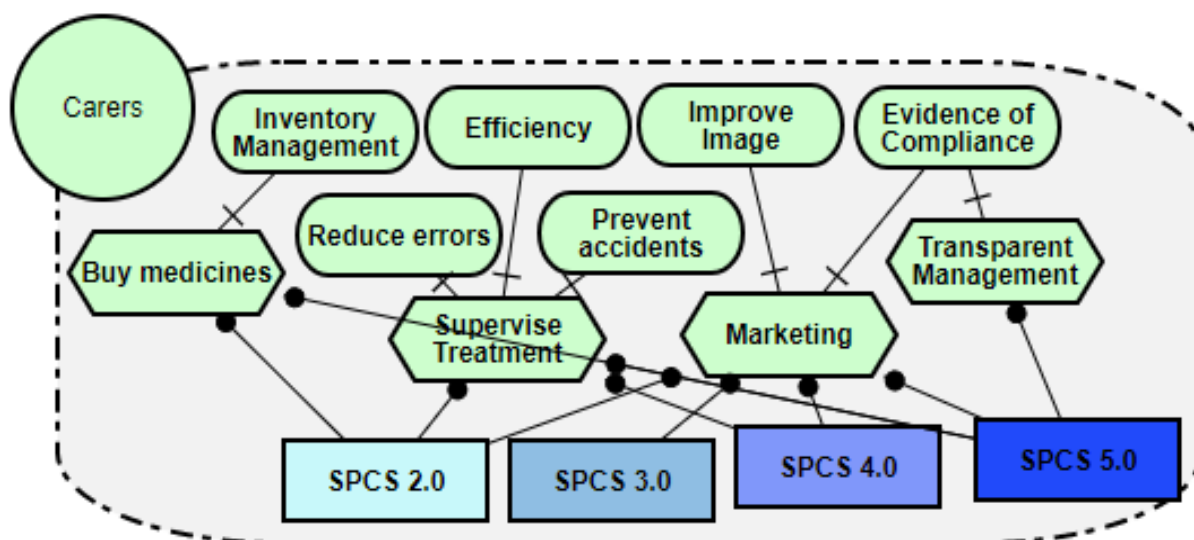

Source: This study.

Figure 3-b: Goal Model for SPCS Design: Carers.

Carers are essential in health service provisions. Therefore, their goals must also be evaluated, namely, the need to monitor inventory (for single patients or multiple patients), ensure both efficiency and safety, and be able to confirm that pharmaceutical care was accomplished according to the requirements / contractual agreements / regulations.

Online information and SMS reminders of SPCS 1.0 can be useful for some patients (e.g., autonomous patients, taking a few drugs) but are less relevant for nursing homes with planned routines. The 100% physical SPCS (2.0) can be important when there are children or potential abuse scenarios (locks) and provide some assistance to carers (monitoring use). Personalization becomes possible with SPCS 3.0 (apps can be tailored to each type of disease) and more advanced features become viable with option 4.0. The SPCS 5.0 adheres to the smart homes trend, extending the physical interaction to cabinets (e.g., RFID, or QR codes to track home inventory and alert, for example, in case of expired or duplicate medicine). The 4.0 generation is also able to project the carers external image of responsibility and quality (e.g., marketing purposes), but only 5.0 can guarantee continuous improvement (big data and AI to learn), fully outsourced inventory management offered by the community pharmacy, and transparency.

Figure 4 outlines the two models of stakeholders that are indirectly related to smart pharmacy services, namely, the society (4-a) that needs to improve health care services using digital technologies, and clinics (4-b) that depend on the quality of medications and on the adherence by patients.

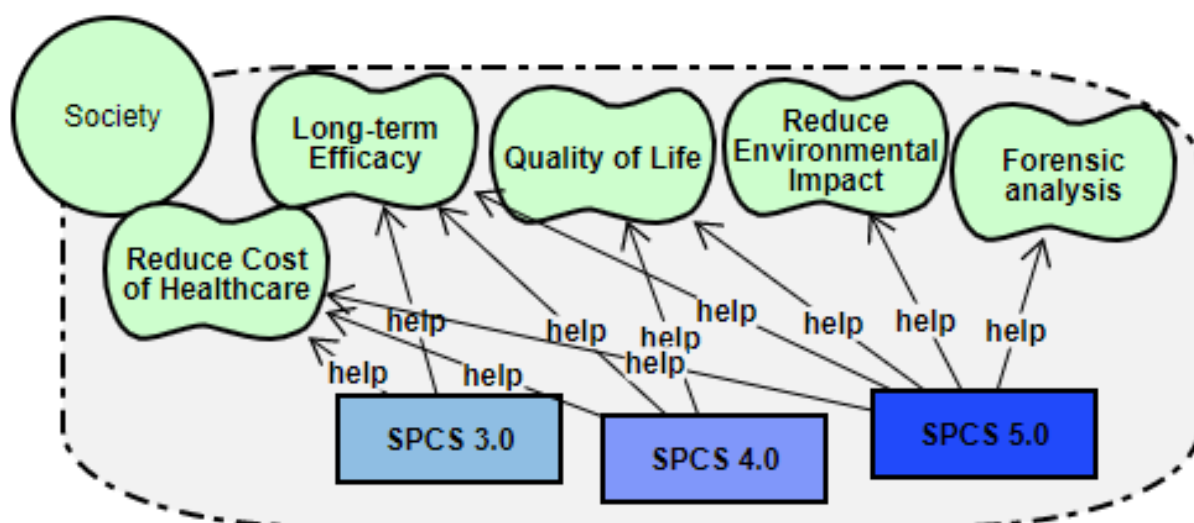

Source: This study.

Figure 4-a: Goal Model for SPCS Design: Society.

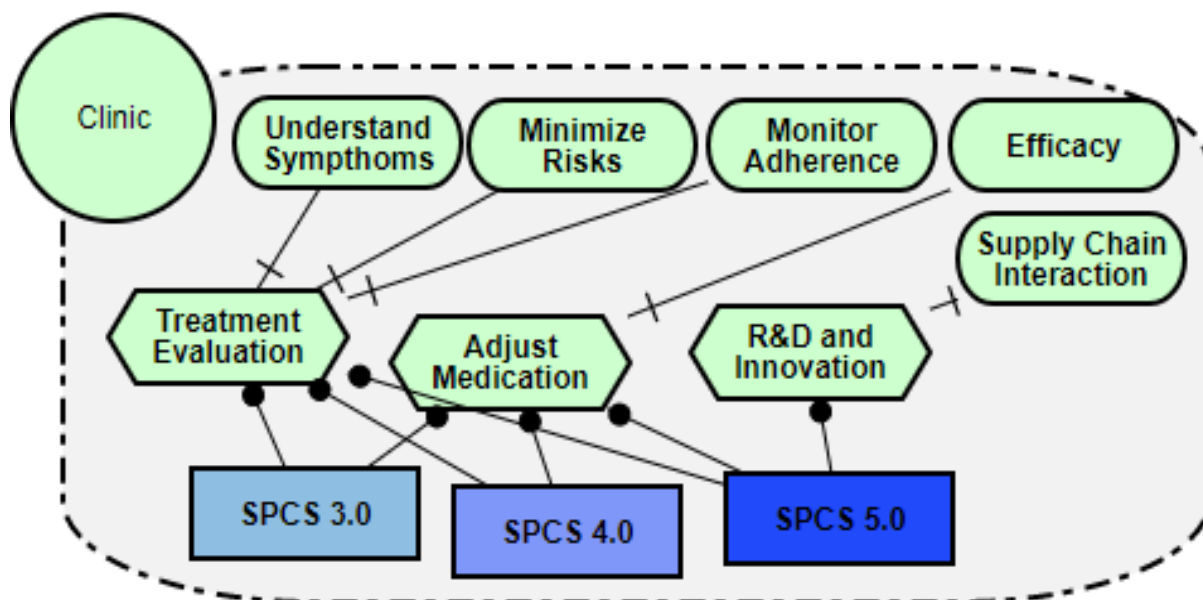

Source: This study.

Figure 4-b: Goal Model for SPCS Design: Clinic.

Health 5.0 requires SPCS that are capable to communicate, not merely to inform. Therefore, static SPCS 1.0 or solely physical devices are no longer sufficient. Reminders (SPCS 1.0) cannot confirm that the patient adhere to the medication and, consequently, follows the treatment as required to improve quality of life and minimize costs of non-adherence. The 100% physical pill dispensers (SPCS 2.0) can contribute to reduce risks at home but are limited to support clinic treatments, adjustments, or more advanced data analytics.

SPCS 3.0 is a possible starting point to address both societal and clinical concerns. SPCS 5.0 extends the (4.0) perspective of reducing “errors” and “cost” to the dimensions of collective intelligence, reliable traceability (e.g., forensic analysis), and medicine reuse/polypharmacy feedback. For example, algorithms can be implemented to check for medicines that will probably expire and create a database for social purposes (e.g., drug recycling) that can be shared by the community of health 5.0 adopters. Nevertheless, current adoption of SPCS (even 1.0) is only starting and the pervasiveness of technology at home environments also raises concerns of security and privacy that must be addressed.

Table 1 summarizes the five generations of SPCS according to the key business stakeholders’ interests, sourcing model, integration in the pharmacy portfolio, and potential new sources of revenue.

Table 1: SPCS business model.

SPCS	Stakeholders Interest	Sourcing Model	Market Offer	New Source of Revenue
1.0	Community Pharmacy, Patient	IT Development	Service to existing customers	N/A
2.0	Community Pharmacy, Patient, Carer	Supplier	New product	Sales margin
3.0	All	IT Development	New service	N/A
4.0	All	Partnership	New product and service	Integrated offer of pharmacy as a service
5.0	All	Partnership	New product, service, and collaboration opportunities	Integrated offer of pharmacy as a service

Source: This study.

According to Table 1, SPCS 3.0-5.0 can support the needs of multiple pharmacy stakeholders. Two SPCS (1.0 and 3.0) are possible to instantiate with software development (app, reminders integrated in the pharmacy information systems), while SPCS 2.0 requires additional competencies. Our case pharmacy decided to become an intermediary of SPCS 2.0. According to the pharmacists, 100% digital SPCS (1.0 and 3.0) are less interesting – benefits still exist in the form of service improvement or customer retention techniques, but the patient may not be willing to pay for these types of SPCSs. SPCS 4.0 and 5.0 are more difficult to create and may require long term relationships between the pharmacy and smart product developers. Both generations can support continuous contact between the pharmacy and their market (patients or companies), but the 5.0 version can extend the community pharmacy business to the producers of smart home solutions and even capture the attention of new partners such as insurance companies, smart home automation companies, and pharmaceutical industries.

This section presents the results of the design stage, modeling the “*stakeholder goals, motivations, and intentions*” (Samavi et al., 2009) and the role of five generations of smart pharmaceutical care systems for home interventions. Each SPCS has its advantages and drawbacks, as discussed in the next section, but are also a starting point to the instantiation of new smart objects for community pharmacies interested in Health 5.0 (QUT, 2018).

DISCUSSION

The IS literature offered many useful insights to model an ecosystem of wellness for community pharmacy projection. SPCS 2.0, and SPCS 4.0 are two types of IT-based medication management that can be included in the pharmacy portfolio, while SPCSs 1.0 and 3.0 (digital) can support service improvements (a pharmacy investment). All types of SPCSs are important, depending on the target customer segment (e.g., smart robots and apps are popular among active adults). Ultimately, SPCS 5.0 incorporates collective intelligence (Marsh et al., 2011). According to the pharmacy managers, the cost of SPCS 5.0 development does not seem discouraging because it could be shared by governments and industry (the cost of SPCSs 1.0-4.0 is almost entirely supported by the pharmacy, the patient, or the carer) with potential return from advanced data analytics.

Personalization requires flexibility to address the needs of all actors in the ecosystem of wellness. It will be interesting to conduct more action-oriented studies to understand the social changes of digital community pharmacies and propose detailed design guidelines for each SPCSs (e.g., regulatory implications, responsibility, protecting the environment and the resources, ensure system resilience, patient safety). Each sector of the economy will need a vision for collective health intelligence (Marsh et al., 2011). We have modeled the case of community pharmacies where the projection into home health care can evolve in different phases, combining five different IT-based medication management systems.

Community pharmacies need to project their interaction across time and space. IT-based reminders (Singh & Varshney, 2020) are a starting point towards a holistic vision of pharmacy at home. Apps are important but not sufficient to prevent errors and assist users with specific health conditions. Physical materialities are necessary in the home health care and community pharmacies are well positioned to lead the process. Technological companies are valuable partners in this effort that can also be extended to the pharmaceutical industry for real-time monitoring of their products use and interaction.

Study Limitations

First, we have completed a foundational DSR iteration aiming at theoretical (RQ1) and conceptual (RQ2) design outcomes. However, only the instantiation of the five SPCS will allow field evaluation that is already planned according to the framework proposed by Venable, Pries-Heje, and Baskerville (2016). Second, although we have made a comprehensive review of recent IS literature, the selection of keywords and databases poses natural limitations. Third, our model was positively evaluated by the experts to start the SPCS instantiations (SPCS 3.0 will be merged in SPCS 4.0 because a physical device is mandatory to the strategy of our case pharmacy company), but more detailed specifications are necessary (e.g., sensors and actuators). Finally, most of the 31 studies are related to hospitals and devices that are not specific to community pharmacies. Therefore, the models emerge from the research team interpretation and projection to the desired context. Contributions to IT-supported use of medication dispensing in hospitals (e.g., incentives) need to be extended and tested in community pharmacies.

Opportunities for Future Research

The next step of our research is the instantiation of SPCS 1.0 and an IoT prototype for SPCS 2.0. The team will evaluate the impact in the costs and service quality of selected nursing homes. Next, SPCS 4.0 will include human-machine (interaction with the clinic), and machine-machine communication (nursing homes). The pharmacy already assured funding for these DSR iterations and plan to submit an international project proposal for SPCS 5.0: collective intelligence in pharmacy. There are also other opportunities. First, smart pillboxes - even the most advanced models with wearables, are only one form to implement customer retention strategies in community pharmacies. It will be necessary to evaluate the impact of projecting different forms of home intervention and integration of external data, for example, via social networks (Sharma, Whittle, Haghghi, Burstein, & Keen, 2020), to improve decision making and circular economy. Second, SPCS certification will be key. Third, IT providers can find this contribution relevant to create new generations of products that minimize workarounds, improve adherence, and allow integration with third-party solutions, for example, polypharmacy databases and AI algorithms.

CONCLUSION

This paper identifies and frames five smart pharmaceutical care systems. An ecosystem of wellness is modelled for this important and unique health care sector. Design science research (Hevner et al., 2004; vom Brocke & Maedche, 2019) is the selected research approach to produce models tailored to a specific set of problems in pharmaceutical setting: project community pharmacies into home health care. The models adopt i* language (Samavi et al., 2009; Yu, 1997) and are the result of our contacts with the community pharmacy and a literature review (Webster & Watson, 2002) of 31 IS publications.

The journey to pharmacotherapy instantiated with smart devices should aim at human-centered health care ecosystems tailored for the needs of each patient, while contributing to health collective intelligence and sustainability challenges. The IS research provided a valuable starting point to incorporate Health 5.0 in pharmacy setting. Community pharmacies are key players in modern health care systems and there are already interesting examples of digital technology adoption. However, digital transformation will require to go *beyond the reminder* (Gatwood et al., 2019) and create new smart solutions to project community pharmacies into home health care.

ACKNOWLEDGMENT

This work is partially supported by the European Regional Development Fund, Regional Operational Program Centro 2020. The authors are grateful to the Conference Committee Co-Chairs and to the review team for their suggestions and insightful comments that greatly improved the quality of the paper.

REFERENCES

- [1] Aaen, J. (2019). Organizing for emerging welfare technology: Launching a drug-dispensing robot for independent living. In *IRIS Proceedings* (pp. 1–17).
- [2] Azad, B., & King, N. (2008). Enacting computer workaround practices within a medication dispensing system. *European Journal of Information Systems*, 17(3), 264–278.
- [3] Bardhan, I., Chen, H., & Karahanna, E. (2020). Connecting systems, data, and people: A multidisciplinary research roadmap for chronic disease management. *MIS Quarterly*, 44(1), 185–200.
- [4] Bednar, P. M., & Welch, C. (2020). Socio-technical perspectives on smart working: Creating meaningful and sustainable systems. *Information Systems Frontiers*, 22(2), 281–298.
- [5] Beerepoot, I. (2019). Working around health information systems: The role of power. In *ICIS Proceedings*.
- [6] Beerepoot, I., Ouali, A., van de Weerd, I., & Reijers, H. A. (2020). Working around health information systems: To accept or not to accept? In *ECIS Proceedings* (pp. 1–15).
- [7] Behne, A., Osnabrück, U., Arlinghaus, T., Osnabrück, U., Osnabrück, U., Teuteberg, F., & Behne, A. (2020). Towards functionalities of self-tracking wearables, their effects on humans and their application areas: Where can we improve? In *AMCIS Proceedings* (pp. 1–10).
- [8] Beuscart, J. B., Petit, S., Gautier, S., Wierre, P., Balcaen, T., Lefebvre, J. M., Kambia, N., Bertoux, E., Mascout, D., Barthélémy, C., Cuny, D., Puisieux, F. & Décaudin, B. (2019). Polypharmacy in older patients: Identifying the need for support by a community pharmacist. *BMC Geriatrics*, 19(1), 1–8.
- [9] Bozan, K., & Berger, A. (2019). Revisiting the technology challenges and proposing enhancements in ambient assisted living for the elderly. In *HICSS Proceedings* (pp. 4307–4316).
- [10] Burkhardt, D., & Burkhardt, D. (2020). A conceptual model of data-driven solutions. In *AMCIS Proceedings* (pp. 1–10).
- [11] Chiasson, M., Kelley, H., & Downey, A. (2015). Understanding task-performance chain feed-forward and feedback relationships in e-health. *AIS Transactions on Human-Computer Interaction*, 7(3), 167–190.
- [12] Davies, M. J., Collings, M., Fletcher, W., & Mujtaba, H. (2014). Pharmacy Apps: A new frontier on the digital landscape? *Pharmacy Practice* (Internet), 12(3), 1–11.
- [13] Dobson, G., Tilson, V., Sullivan, S., & Webster, D. (2019). Reducing costs of managing medication inventory in automated dispensing system in hospital units. In *HICSS Proceedings* (Vol. 6, pp. 6782–6789).
- [14] Gabel, M., Münster, W. W. U., Nüesch, S., & Gabel, M. (2019). The (in)effectiveness of incentives - A field experiment on the adoption of personal electronic health records. In *ICIS Proceedings*.
- [15] Gao, F., Briggs, R. O., Thiebes, S., & Sunyaev, A. (2019). Multi-organizational multi-stakeholder collaboration systems: An exploratory research study of design concerns in healthcare. In *HICSS Proceedings* (pp. 512–521).
- [16] Gatwood, J., Hohmeier, K. C., & Brooks, I. M. (2019). Beyond the reminder: The next steps in pharmacist-driven, mHealth patient engagement. *Journal of the American Pharmacists Association*, 59(2), S21–S24.
- [17] Gerhardt, U., Breitschwerdt, R., & Thomas, O. (2018). mHealth engineering: A technology review. *Journal of Information Technology Theory and Application*, 19(3), 82–117.
- [18] Hayes, T. L., Hunt, J. M., Adami, A., & Kaye, J. A. (2006). An electronic pillbox for continuous monitoring of medication adherence. *IEEE EMBS Proceedings*, 6400–6403.
- [19] Heikkilä, M., Bowman, H., & Heimo, O. (2019). Does BMI help business to succeed? In *Bled eConference Proceedings*.
- [20] Hevner, A. R., March, S. T., Park, J., & Ram, S. (2004). Design science in information systems research. *MIS Quarterly*, 28(1), 75–105.
- [21] Imre, Ö., & Wass, S. (2019). Trends in patient generated data – An initial review. In *HICSS Proceedings* (pp. 4146–4154).
- [22] Javaid, M., & Haleem, A. (2019). Industry 4.0 applications in medical field: A brief review. *Current Medicine Research and Practice*, 9(3), 102–109.
- [23] Johnsen, H. M., Fruhling, A., & Fossum, M. (2016). An analysis of the work system framework for examining information exchange in a healthcare setting. *Communications of the Association for Information Systems*, 39(1), 73–95.
- [24] Karlsen, C., Haraldstad, K., Moe, C. E., & Thygesen, E. (2019). Challenges of mainstreaming telecare. Exploring actualization of telecare affordances in home care services. *Scandinavian Journal of Information Systems*, 31(1), 31–66.
- [25] Kempton, A. M., & Bränden, K. (2020). Infrastructural tuning in public-private partnerships. In *ECIS Proceedings*.
- [26] Liu, N., Yin, J., Wongmaneroj, M., & Teo, H. (2020). The design of digital health applications for elderly users: A systematic review and future directions. In *PACIS Proceedings* (pp. 1–9).
- [27] Liu, X., & Varshney, U. (2019). Reminders and negative reinforcement in intervention for medication adherence. In *AMCIS Proceedings* (pp. 1–5).
- [28] Marsh, A., Carroll, D., & Foggie, R. (2011). Collective health intelligence: A tool for public health. In *Future Visions on Biomedicine and Bioinformatics* (pp. 21–41).
- [29] Mesbah, N., & Pumplun, L. (2020). “Hello, I’m here to help you” – Medical care where it is needed most: Seniors’ acceptance of health chatbots. In *ECIS Proceedings*.

- [30] Peffers, K., Tuunanen, T., Rothenberger, M. A., & Chatterjee, S. (2007). A design science research methodology for information systems research. *Journal of Management Information Systems*, 24(3), 45–78.
- [31] Porter, M. E., & Heppelmann, J. E. (2015). How smart, connected products are transforming companies. *Harvard Business Review*, 2015(October).
- [32] QUT. (2018). *Health 5.0*. Retrieved August 10, 2020, from <https://www.qut.edu.au/health/about/news?news-id=125936>
- [33] Samavi, R., Yu, E., & Topaloglou, T. (2009). Strategic reasoning about business models: A conceptual modeling approach. *Information Systems and E-Business Management*, 7(2), 171–198.
- [34] Savoli, A., Barki, H., & Pare, G. (2020). Examining how chronically ill patients' reactions to and effective use of information technology can influence how well they self-manage their illness. *MIS Quarterly*, 44(1), 351–389.
- [35] Schmidt-Kraepelin, M., Warsinsky, S., Thiebes, S., & Sunyaev, A. (2020). The role of gamification in health behavior change: A review of theory-driven studies. In *HICSS Proceedings* (pp. 1256–1265).
- [36] Schuetz, S., & Venkatesh, V. (2020). Research perspectives: The rise of human machines: How cognitive computing systems challenge assumptions of user-system interaction. *Journal of the Association for Information Systems*, 21(2), 460–482.
- [37] Sharma, C., Whittle, S., Haghghi, P. D., Burstein, F., & Keen, H. (2020). Sentiment analysis of social media posts on pharmacotherapy: A scoping review. *Pharmacology Research & Perspectives*, 8(5), 1–9.
- [38] Simon, H. (1996). *The Sciences of the Artificial* (Third Edition). MIT Press.
- [39] Singh, N., & Varshney, U. (2020). IT-based reminders for medication adherence: Systematic review, taxonomy, framework and research directions. *European Journal of Information Systems*, 29(1), 84–108.
- [40] Sittig, S., Franklin, A. L., & Sittig, S. (2020). Persuasive technology: Designing mobile health triggers to impact health behavior. In *AMCIS Proceedings* (pp. 1–10).
- [41] Solís, W. V., Cedillo, P., Parra, J., Guevara, A., & Ortiz, J. (2017). Intelligent pillbox: Evaluating the user perceptions of elderly people. In *ISD Proceedings*.
- [42] Son, J., Flatley Brennan, P., & Zhou, S. (2020). A data analytics framework for smart asthma management based on remote health information systems with bluetooth-enabled personal inhalers. *MIS Quarterly*, 44(1), 285–303.
- [43] Strobel, G., & Perl, J. (2020). Health in the era of the internet of things - A smart health information system architecture. In *PACIS Proceedings*.
- [44] Thuan, N. H., Drechsler, A., & Antunes, P. (2019). Construction of design science research questions. *Communications of the Association for Information Systems*, 44(1), 332–363.
- [45] Varshney, U., & Singh, N. (2020). Opioid use disorder: Studying quality of life with IT-based interventions. In *AMCIS Proceedings* (pp. 1–10).
- [46] Venable, J., Pries-Heje, J., & Baskerville, R. (2016). FEDS: A framework for evaluation in design science research. *European Journal of Information Systems*, 25(1), 77–89.
- [47] vom Brocke, J., & Maedche, A. (2019). The DSR grid: Six core dimensions for effectively planning and communicating design science research projects. *Electronic Markets*, 29(3), 379–385.
- [48] Wainwright, D., Whalley, J., Bhattacharya, S., Wainwright, D., & Whalley, J. (2020). Designing sustainable business models for telehealthcare services adoption: A critical realism informed case study approach. In *UKAIS Proceedings*.
- [49] Webster, J., & Watson, R. T. (2002). Analyzing the past to prepare the future. *MIS Quarterly*, 26(2), xiii–xxiii.
- [50] Xie, W., Palvia, P., & Vance, L. (2020). Value co-creation and challenges in electronic health record (EHR). In *ICIS Proceedings*.
- [51] Yang, H., Guo, X., Peng, Z., Lai, K. H., & Luo, J. (2020). The impact of patient experience from e-health on conscious competence and medication adherence. In *PACIS Proceedings*.
- [52] Yu, E. S. K. (1997). Towards modelling and reasoning support for early-phase requirements engineering. In *ISRE Proceedings* (pp. 226–235).

Research on Consumers' Buying Behavior in the Context of "Helping Farmers Live": Based on the Dual Role of Economic Rationality and Normative Rationality

(Full Paper)

Xiaolin Li, Sichuan Agricultural University, China, 57929606@qq.com
Mengqian Guo*, Sichuan Agricultural University, China, 1766457224@qq.com
Dunhu Huang, Sichuan Agricultural University, China, 1287301356@qq.com

ABSTRACT

Abstract: As the digital economy has become an important driving force for a new round of global industrial change, live e-commerce has become a new outlet, and the "agriculture assisted live broadcasting" has emerged. This paper combs the existing literature and combines the characteristics of "agriculture assisted live broadcasting" to get a theoretical research model of consumers' purchasing behavior in the context of "assisted farmer direct broadcast". Using questionnaire survey method to collect data for empirical analysis, the research found that consumers' perceived risk negatively affects purchase intention; efficacy positively affects purchase intention; consumer purchase intention positively affects purchase behavior; consumer perceived value and social norms have no significant effect on purchase intention. Finally, this article makes suggestions for businesses and relevant departments of the live broadcast industry.

Keywords: Help farmers live broadcast, economic rationality, normative rationality, purchasing behavior research

*Corresponding author

INTRODUCTION

The digital wave promotes the construction of a live broadcast ecosystem for enterprises and is becoming a new engine driving economic growth. In 2018, the scale of my country's digital economy doubled that of 2014, reaching 31.3 trillion yuan, accounting for 34.8% of GDP. In the long run, live video streaming has become an important driving force for enterprises' digital transformation. According to the survey, short videos, long videos, and live broadcasts account for more than 45% of the content marketing forms that consumers have come into contact with. In the short term, the epidemic has become a catalyst for the digital transformation of enterprises. As of March 2020, my country's e-commerce live broadcast users accounted for 29.3% of the total netizens (iResearch, 2020). Under the influence of the country's precise poverty alleviation strategy, "assisting farmers live broadcast" has emerged. In June 2020, the Circulation Industry Promotion Center of the Ministry of Commerce issued a notice to host the national agricultural and commercial interconnection to help farmers live and carry goods, encouraging leaders of government departments at all levels and anchors to live and carry goods.

Under the background of this year's epidemic, the circulation of agricultural products has been blocked and the sales of agricultural products have been blocked. Major broadcasters have cooperated with government leaders, CCTV hosts, and entertainment stars to carry out "Agricultural Live Broadcasting" to help farmers sell their agricultural products. Helping farmers live broadcast is faced with problems such as lax supervision, consumer distrust, data falsification, and commodity sales. There are many views but the transaction rate is not high. How to increase the transaction rate in the live broadcast is an urgent problem that needs to be solved.

This article defines the live broadcast of agricultural assistance as a live broadcast activity initiated on the Internet e-commerce platform to help agricultural producers sell agricultural products. "Helping farmers live broadcast" has the dual attributes of public welfare and low prices. Consumers' behavior of purchasing agricultural products in "helping farmers live broadcast" is given multiple meanings due to the dual attributes. The theory of social exchange believes that the interaction between people is essentially a process of obtaining the maximum benefit for the least cost, which is human economic rationality (Krebs, 1970); the theory of social norms believes that the interaction between people is also driven by an altruistic society. The influence of norms is human normative rationality. When making purchase decisions, consumers' behavior is driven by both economic rationality and normative rationality. In the dual context of "helping farmers live broadcast", whether economic rationality or normative rationality plays a key role in consumer purchasing behavior? In order to explore this problem, this paper conducts an empirical study on consumers' purchase behavior in the context of "direct broadcast of agricultural assistance" from two aspects of economic rationality and normative rationality through questionnaire survey, and draws research conclusions, which can provide constructive suggestions for the practice of live broadcast of agricultural assistance.

LITERATURE REVIEW AND RESEARCH HYPOTHESIS

Consumers' Economic Rationality and Its Influencing Factors

A basic assumption of economics is the "economic man" assumption. "Economic man" assumes that the economic actions taken by every person engaged in economic activities are trying to obtain their own maximum economic benefits at their own minimum economic costs. In any economic activity, only such people are "rational people." Herbert Simon defined "rationality" as "a way of achieving a specified goal within given conditions and constraints." This article defines the economic rationality of consumers in the process of purchasing behavior as consumers who will always make the most beneficial purchasing choice under the existing conditions when making purchasing behavior decisions (Tomer, 2008). Through the establishment of online consumption scenes, the help farmer live broadcast allows consumers to experience real-time interaction similar to offline consumption scenes and stimulate consumption desire. In order to obtain brand exposure and introduce low-cost traffic, the supplier of the help farmer live broadcast will provide products and services below the market price for the live broadcast room. Consumers can reduce the cost of information acquisition and obtain limited time and low price during the live broadcast to reduce the purchase cost. The live interactive experience can also greatly reduce the perceived risk of online shopping. In conclusion, consumers' perceived value and perceived risk are key factors that affect their purchasing decisions in helping farmers live broadcast. Therefore, this article selects perceived value and perceived risk as the influencing factors of consumer purchase intention in the context of "helping farmers live broadcast".

Perceived value is the overall evaluation of the utility of a product or service that consumers get after weighing the perceived benefits and sacrifices to obtain a product or service. Consumers' perceived value is their subjective evaluation based on their subjective feelings about the products or services they obtain (Chen, 2003). In previous studies, scholars divided perceived value into different dimensions (Sheth, Newman & Gross, 1991). This study selects quality value and price value in Sweeney's division and definition of perceived value (Sweeney, & Soutar, 2001). Quality value refers to the utility brought about by comparing the perception of the quality of the product or service obtained by the customer after purchasing the product or service with their expectations. Price value refers to the utility of the cost reduction that customers feel during the purchase process. It has been proved that perceived value can predict consumers' purchase intention. Zeithaml's (1998) research proves that consumers' perceived value of a product or service significantly positively affects their purchase intention. The conclusion that the greater the perceived value, the stronger the consumer's willingness to buy, has been verified in most studies (Zeithaml, Berry, & Parasuraman, 1996). In the context of helping farmers live broadcast, what consumers intuitively feel is the quality and price of the products. The lower the price, the better the quality, the greater the perceived value and the stronger the purchase intention. Therefore, this paper makes the following assumptions:

H1: Consumers' perceived value has a significant positive impact on consumers' purchase intention in the context of "helping farmers live broadcast"

Perceived risk refers to consumers' psychological feelings of worry due to the uncertainty of the result when making purchase decisions. (Laforet, 2010). Harvard University professor Bauer pointed out that perceived risk is not the actual risk but the subjective perception of the negative impact that consumers may have on their choices. If consumers do not feel the risk when making a purchase decision, then risk factors will not affect the consumer's decision. Scholars at home and abroad have divided the dimensions of perceived risk when they study it. Cox and Rich (1964) divide perceived risk into two aspects: financial and social psychology. Jarvenpaa and Todd are (1996) the first to propose that the perceived risks faced by consumers in the Internet environment are mainly from five sources: function, security, economy, society, and privacy. Privacy risk is the first It appears in the division dimension of perceived risk. Relevant research shows that consumers are more likely to make purchase decisions when the perceived risk is low enough to make consumers feel that they can bear the risks that may bring bad results (Corritore, Kracher, & Wiedenbeck, 2003). A number of empirical studies have shown that the smaller the perceived risk, the stronger the consumer's willingness to buy (Xie & An, 2020). When shopping in the live broadcast of agricultural assistance, consumers are faced with risks such as the inconsistency between the real object and the live broadcast explanation, and the after-sales service cannot be guaranteed. These risks will make consumers spend more time weighing before making purchase decisions. Once consumers feel that the risk is beyond their acceptable range, they will stop buying. That is, the stronger the risk perceived by consumers, the weaker the purchase intention. Therefore, this paper makes the following assumptions:

H2: Consumers' perceived risk in the context of "helping farmers live broadcast" has a significant negative impact on consumers' purchase intention.

Consumer's Normative Rationality and Its Influencing Factors

People are driven by economic interests and have stood firm in the history of economics for many years. Economic rationality can explain many human behaviors. With the advancement of society, people who "know the etiquette in a hurry" and don't have to worry about basic livelihood security begin to consider the impact that their actions may have on society. Studies have shown that Chinese consumers are collectivist, and they may sacrifice their own interests to make behaviors that conform to social norms, that is, people are normative and rational (Yau, 1988). This article defines normative rationality as consumers who perceive normative factors such as social groups' value orientation, ethics and morals, and then make behaviors consistent with the standards recognized by social groups (Long, 2010). "Aid-agricultural live broadcast" has a public welfare attribute due to its characteristics of assistance to farmers. Consumers may feel that they can help farmers outsell agricultural products and have a positive impact on farmers' lives and make purchases that conform to social norms. Therefore, this paper selects

social norms and sense of efficacy as the influencing factors of consumers' purchase intention in the context of "helping farmers live broadcast".

Social norms refer to the society's attitudes towards individual behaviors. In order to gain group recognition, individuals will actively adopt social norms as their own code of conduct (Sunstein, 2014). Studies have shown that there are two formation paths for the influence of social norms on consumers' socially responsible consumption behaviors in the Chinese context: "internalization mode" and "stress mode". "Internalization mode" refers to consumers transforming social norms into personal values Concepts, which in turn guide their behavior, "stress mode" refers to consumers who are forced by external pressure to adopt socially responsible consumption behaviors just to conform with others in order to conform to the crowd (Long, Tian & Hou, 2016). The "normative focus theory" divides social norms into "descriptive norms" and "command norms" (Cialdini, Kallgren, & Reno, 1991). Sheng and Ge (2019) focused on imperative norms from the perspective of social interaction theory, and found through comparative experiments that imperative norm information can enhance consumers' green purchase intentions compared with ordinary environmental protection information. Social norms play an important role in consumers' socially responsible consumption and other pro-social behaviors. Wang and Lei (2015) divide the formation mechanisms of socially responsible consumption into three categories. Among them, the social norm mechanism belongs to the middle-end mechanism, explaining how external social norms are playing a role. Existing domestic and foreign studies on social norms on consumer's socially responsible consumption behaviors have all proved that social norms positively affect socially responsible consumer behaviors. Because of the characteristics of assisting farmers, direct seeding has pro-social attributes, and will form social norms in social groups to affect consumers' purchase intentions. Therefore, this article makes the following assumptions:

H3: In the context of "helping farmers live broadcast", social norms have a significant positive impact on consumers' purchase intention.

According to the theory of social norms, social norms can stimulate people's pro-social behaviors, but studies have found that consumers' socially responsible consumption behaviors are also affected by consumers' self-efficacy. Efficacy in the field of management marketing refers to consumers' subjective judgments about the positive impact that their efforts may have on the environment and society when they conduct socially responsible purchases. It is consumers' expectations of the results (Long *et al.*, 2020). Starting from the psychological distance that affects socially responsible consumption, Wang and Lei (2015) use the efficacy-attitude-behavior (willingness) model as a near-end mechanism, mainly explaining the influence of consumers' internal psychological factors. The empirical research of scholars such as Long *et al.* (2020) has shown that when the level of efficacy or proactive personality is high, it can effectively reduce the intention-behavior gap of socially responsible consumption. When consumers perceive that their buying behavior can change their environment or society, they will be more inclined to make behaviors. In the live broadcast of helping farmers, consumers who are persuaded by the anchor will have a stronger sense of efficacy and more likely to produce purchase intentions. Therefore, this article makes the following assumptions:

H4: In the context of "helping farmers live broadcast", consumer's sense of efficacy has a significant positive impact on purchase intention.

The Influence of Consumers' Purchasing Intention on Purchasing Behavior

The theory of planned behavior believes that an individual's behavior is affected by his behavioral willingness of that kind of behavior, and other factors all influence behavior through behavioral willingness (Ajzen & Driver, 1992). In the research field of socially responsible consumption, the effect of purchase intention on socially responsible consumption behavior is regulated by factors such as sense of efficacy, initiative personality, ethical cognitive effort, and material environment. This article believes that consumers' purchase intention can still predict purchase behavior in the context of helping farmers live broadcast. Therefore, this article makes the following assumptions:

H5: In the context of "helping farmers live broadcast", consumers' purchase intention has a significant positive impact on purchase behavior.

Therefore, the theoretical model of this research is shown in Figure 1:

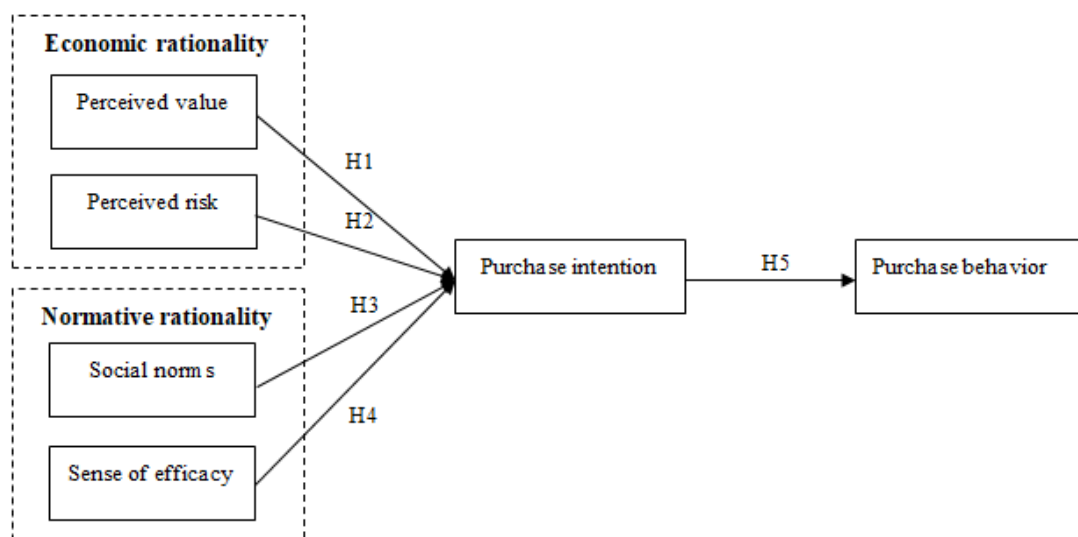

Figure 1: Research model

RESEARCH DESIGN AND EMPIRICAL ANALYSIS

Scale Design and Data Collection

This article refers to the live broadcast and the mature scales in the literature related to social responsibility consumption behaviors to modify and improve, and add the feature of "help farmers live broadcast" without changing the basic meaning of the measurement items. Each item used Five-level Likert scale. Table, and finally got a total of 25 measurement items for six variables.

The questionnaire includes two parts: a survey of the respondents' basic information and a measurement scale. The questionnaire is made using "Questionnaire Star" and distributed through online social platforms in the form of links. Finally, 242 questionnaires were collected and sorted out. After excluding invalid questionnaires, 222 valid questionnaires were obtained, with an effective rate of 91.7%.

Descriptive Statistical Analysis

The descriptive statistical analysis of the respondents' basic information is shown in Table 1:

Basic Features	Classification	Number of Samples	Proportion(%)
Gender	Male	70	31.5
	Female	152	68.5
Age	18-28 years old	190	85.6
	29-44 years old	21	9.5
	45 years old and above	11	5.0
Education	Junior high school and below	10	4.5
	High school	7	3.2
	Specialist	26	11.7
Monthly consumption level	Undergraduate	125	56.3
	Master degree and above	54	24.3
	Below 1000 yuan	16	7.2
Monthly consumption level	1000-2000 yuan	131	59.0
	2000-3000 yuan	40	18.0
	3000 yuan or more	35	15.8

Reliability and Validity Test

Reliability Test

This article uses Cronbach's α coefficient to evaluate the reliability of the collected samples. It is generally believed that the Cronbach's α coefficient is greater than 0.7, and the scale has high reliability. The results of Cronbach's α coefficients of the variables in this paper are shown in Table 2:

Table 2: Reliability Test

Variable	Perceived value	Perceived risk	Social norms	Self-efficacy	Purchase Intention	purchase behaviour
Cronbach's α	0.772	0.798	0.737	0.791	0.770	0.835

From the results in Table 2, it can be seen that the Cronbach's α coefficient of each variable is greater than 0.7, and the overall validity of the scale is 0.869, which is greater than 0.8. The reliability of the scale is good.

Validity Test

The scale of this article refers to a large number of mature scales, which have high content validity. Exploratory factor analysis is used to test the validity of the structure. The KMO and Bartlett sphere tests are first performed on the scale. It is generally believed that KMO greater than 0.7 indicates that it is suitable for factor analysis. The test results of each variable are shown in Table 3:

Table 3: KMO and Bartlett's test

KMO	.874
Bartlett's test	2025.276
df	171
Sig	.000

The KMO and Bartlett sphere test results show that the KMO value is 0.874, which is greater than 0.7. The Bartlett sphere test is significant and can be used for factor analysis. The factor analysis uses principal component analysis to extract the characteristic value of each factor that is greater than 1, and the cumulative variance of the explanatory variable is 63.54%, which exceeds 50%. At the same time, the factor loading of each observation item is above 0.5, and the scale structure validity is good.

Hypothetical Test

This article uses Amos 24.0 to fit the model and hypothesis test. The model fit index is shown in Table 4:

Table 4: Model Fit Index

Index	IFI	TLI	CFI	RMSEA	CMIN/DF
Model fit	.857	.824	.855	.095	2.977

The results show that: IFI, TLI, and CFI indicators are greater than 0.8, within the acceptable range, RMSEA is 0.095, less than 1, and the degree of adaptation is acceptable, and CMIN/DF is 2.997, less than 3, which is acceptable, and the model has a good degree of adaptation. Subsequent hypothesis verification can be performed. The path verification results are shown in Table 5, and the model of test results is shown in Figure 2.

Table 5: Hypothesis Test

Research hypothesis	Path coefficient
H1: Consumers' perceived value has a significant positive impact on consumers' purchase intention in the context of "helping farmers live broadcast"	-0.047

H2: Consumers' perceived risk in the context of "helping farmers live broadcast" has a significant negative impact on consumers' purchase intention.	-0.175**
H3: In the context of "helping farmers live broadcast", social norms have a significant positive impact on consumers' purchase intention.	0.130
H4: In the context of "helping farmers live broadcast", consumer's sense of efficacy has a significant positive impact on purchase intention.	0.916***
H5: In the context of "helping farmers live broadcast", consumers' purchase intention has a significant positive impact on purchase behavior.	0.645***

Note: * $p < 0.1$, ** $p < 0.05$, *** $p < 0.01$ mean significant levels.

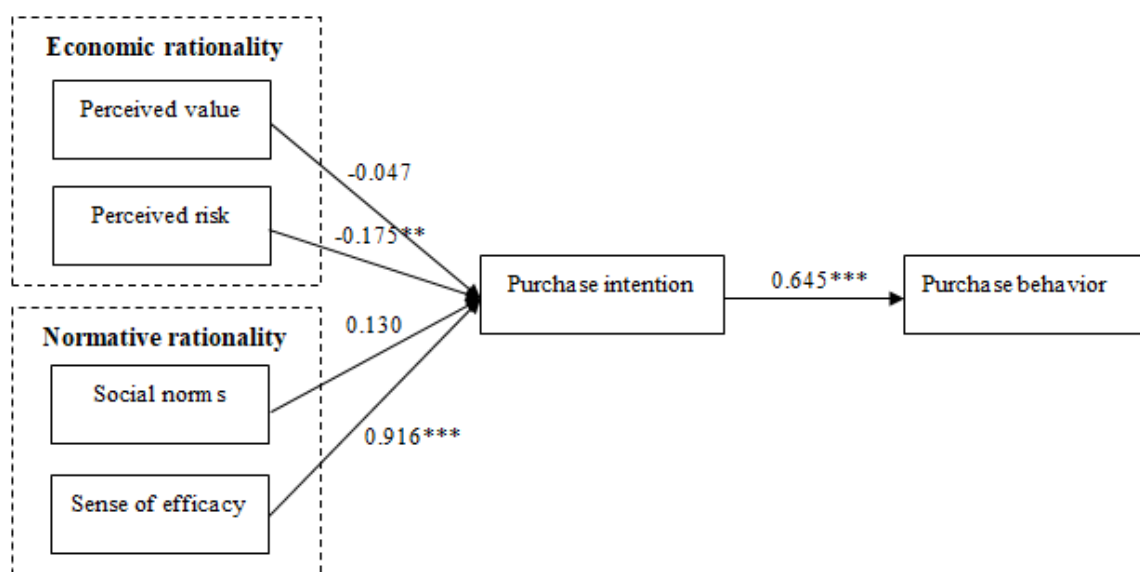

Note: * $p < 0.1$, ** $p < 0.05$, *** $p < 0.01$ mean significant levels.

Figure 2: The Model of Test Results

According to the results of hypothesis path test, hypothesis 1 does not pass the significance test for the influence of perceived value on purchase intention; hypothesis 2 has significant negative effect on purchase intention with path coefficient of 0.175; hypothesis 3 has no significant effect on purchase intention; Hypothesis 4 has significant positive effect on purchase intention The path coefficient is 0.916; Hypothesis 5 shows that the positive impact of consumers' purchase intention on purchase behavior passes the significance test, and the path coefficient is 0.645.

ANALYSIS CONCLUSION

First of all, consumer perceived risk has a negative impact on purchase intention. In online shopping, consumers feel that the higher the risk factors such as the insecurity of funds, the possibility of privacy leakage and the uncertainty of receiving products, the lower the possibility of purchasing intention. Live broadcasting is an important means to attract and sell goods in the e-commerce industry in the past two years. Various platforms and industries have joined the live network to bring goods. On the one hand, live broadcasting can bring benefits to the business platform and consumers. On the other hand, due to the excessive number of participants, the live broadcasting industry is full of talents and talents, which enhances consumers' risk perception of live broadcasting. At the present stage, China has not formed a sound regulatory system to supervise the live broadcast chaos, and the live broadcast selling fake goods, the anchor combined with businesses to cheat fans and other events occur frequently. Although it has the attribute of "helping agriculture", consumers' risk perception is still strong and their willingness to buy will be greatly reduced. Agricultural products are seasonal products, transportation damage and cycle factors will also increase consumer perceived risk and reduce purchase intention. The Enlightenment of this conclusion for live broadcast businesses is that they should strive to establish a positive corporate image, do not fake, sell fake, do not make false preferential publicity, ensure that the quality of the products advertised in the live broadcast room is consistent with the products sold, and that there will be no large loss in the transportation of goods. Consumers will feel that the enterprise is trustworthy, product quality and service can be guaranteed, and consumption can be reduced Consumers perceive the risk and

improve the purchase intention. The suggestions to the regulatory authorities are to improve the regulatory system, standardize the live broadcasting industry, reduce the occurrence of fake sales, and improve the consumer's preference for live broadcast.

Second, in the context of "helping farmers live", consumer efficacy has a positive impact on purchase intention. Consumer efficacy is a kind of subjective feeling, that is, the greater the positive impact that consumers can bring to farmers and society, the stronger their willingness to buy. Some studies have shown that, compared with the fuzzy expression of donation amount, clear expression of donation amount can cause more positive response from consumers (Zhang, Xu & Yu, 2020). In this paper, the author believes that the clearer and more specific the anchor's positive impact on consumers' purchase behavior, the stronger the sense of consumer efficacy and the stronger the purchase intention. The Enlightenment of this conclusion for businesses is that the anchor can highlight how much products can be sold to farmers and stakeholders, and stimulate consumers' sense of efficacy through specific description, so as to improve their purchase intention.

Third, consumers' purchase intention has a positive impact on their purchase behavior. According to the theory of planned behavior, behavioral intention can predict behavior. In this context, the predictive effect of purchase intention on purchase behavior is also proved. That is, the stronger the consumer's purchase intention, the stronger the possibility of purchasing behavior. Therefore, businesses should strive to improve the willingness of consumers to purchase and promote their purchasing behavior.

Fourth, the positive impact of consumer perceived value and social norms on purchase intention is not established. The reason why the influence of perceived value on purchase intention has not passed the significance test may be that perceived value can be divided into many dimensions, but in this study, it is only divided into price value and quality value, and the concept passed to the subjects is not clear and specific, resulting in errors; it may also be that the live broadcasting industry is not strictly regulated, the quality of products is mixed, and there is no mature industry standard. Consumers feel that they can't buy the products with better value in the live broadcast, the perceived value is low, and the purchase intention is not strong. The Enlightenment of this to the live broadcast side is that to carry out the agricultural live broadcast, we should really provide consumers with high-quality and low-cost products, avoid false publicity, and let consumers feel that they can buy products with good value in the live broadcast of agricultural assistance.

The positive effect of social norms on purchase intention is not significant. The reason may be that the product category of agricultural products has not attracted enough attention of consumers. The behavior of purchasing commodities in the live broadcast of agricultural assistance will not be recognized by social groups. If social norms are not formed, it will not affect the purchase intention. The enlightenment to the relevant departments is that we should vigorously publicize the negative impact of unsalable agricultural products on the economy and society, and call on people to buy more agricultural products and help social groups form social norms related to helping agriculture.

RESEARCH LIMITATIONS AND PROSPECTS

The above research conclusions verify the correctness of the starting point of this article "consumer purchasing behavior in helping farmers live broadcast by economic rationality and normative rationality", but it also illustrates the complexity of consumer normative and normative rationality. The scenario of "assisting farmers live broadcast" selected in this article has strong research value, but the author's ability is limited and various conditions are restricted. This article has certain limitations in the exploration of economic rationality and normative rationality.

Future research can divide the perceived value into different dimensions according to the characteristics of the live broadcast of the farmers, such as quality value, price value, emotional value, social value, etc., and explore the effect of each dimension on consumers' purchase intention; for economic rationality and normative rationality The selection of variables in the two aspects can also be innovated and explored in depth; adjustment variables such as government policies and consumer personal characteristics can also be added to explore whether different external conditions or consumer characteristics will affect economic rationality and normative rationality.

REFERENCES

- [1] Ajzen, I., & Driver, B.L. (1992). Application of the theory of planned behavior to leisure choice. *Journal of Leisure Research*, 24(3), 207-224.
- [2] Chen, M.L. (2003). An experimental research on the determinants of customer repurchase intention. *Scientific Research Management*, 24(001), 110-115. doi: 10.3969/j.issn.1000-2995.2003.01.020
- [3] Cialdini, R.B., Kallgren, C.A., & Reno, R.R. (1991). A focus theory of normative conduct: A theoretical refinement and reevaluation of the role of norms in human behavior. In *Advances in Experimental Social Psychology* (Vol. 24, pp. 201-234). Academic Press. doi: 10.1016/S0065-2601(08)60330-5
- [4] Corritore, C.L., Kracher, B., & Wiedenbeck, S. (2003). On-line trust: concepts, evolving themes, a model. *International Journal of Human-Computer Studies*, 58(6), 737-758. doi: 10.1016/S1071-5819(03)00041-7
- [5] Cox, D.F., & Rich, S.U. (1964). Perceived risk and consumer decision-making—the case of telephone shopping. *Journal of Marketing Research*, 1(4), 32-39. doi: 10.1177/002224376400100405

- [6] iResearch(2020). 2020 China Live E-commerce Ecological Research Report. Retrieved from https://www.iresearch.cn/include/ajax/user_ajax.ashx?work=idown&rid=3606
- [7] Jarvenpaa, S. L., & Todd, P. A. (1996). Consumer reactions to electronic shopping on the World Wide Web. *International Journal of Electronic Commerce*, 1(2), 59-88. doi: 10.1080/10864415.1996.11518283
- [8] Krebs, D. L. (1970). Altruism: An examination of the concept and a review of the literature. *Psychological Bulletin*, 73(4), 258-302. Doi: 10.1037/h0028987
- [9] Laforet, S. (2008). Retail brand extension—perceived fit, risks and trust. *Journal of Consumer Behaviour: An International Research Review*, 7(3), 189-209. doi: 10.1002/cb.245
- [10] Long, X. & Tian, Z. (2010). Normative rationality affecting consumer behavior. *Journal of Hunan University (Social Science Edition)* (05), 69-73. doi: 10.3969/j.issn.1008-1763.2010.05.012.
- [11] Long, X., Deng, X., Yang, S. & Munkhbayar, K. (2020). Corporate social responsibility, purchasing intention and purchasing behavior: The mediating role of active personality and self-efficacy. *Journal of System Management* (04), 646-656.
- [12] Long, X.F. (2010). Research on consumer normative rationality. (Doctoral dissertation, Huazhong University of Science and Technology). doi: 10.7666/d.d152720
- [13] Long, X.F., Tian, Z.L. & Hou, J.D. (2016). The impacts of social norms to socially responsible consumer behavior in China. *Chinese Journal of Management*. doi: 10.3969/j.issn.1672-884x.2016.01.015
- [14] Sheng, G.H. & Ge, W. (2019). Research on the social mechanism driving consumers' green purchases from the perspective of social interaction. *Journal of Huazhong Agricultural University (Social Science Edition)* (02), 81-90+167. doi: 10.13300/j.cnki.hnwkxb.2019.02.010.
- [15] Sheth, J.N., Newman, B.I., & Gross, B.L. (1991). Why we buy what we buy: A theory of consumption values. *Journal of Business Research*, 22(2), 159-170. doi: 10.1016/0148-2963(91)90050-8
- [16] Sunstein, C.R. (1996). Social norms and social roles. *Columbia Law Review*, 96(4), 903-968.
- [17] Sweeney, J.C., & Soutar, G.N. (2001). Consumer perceived value: The development of a multiple item scale. *Journal of Retailing*, 77(2), 203-220. doi: 10.1016/S0022-4359(01)00041-0
- [18] Tomer, J. (2008). Beyond the rationality of economic man, toward the true rationality of human man. *The Journal of Socio-Economics*, 37(5), 1703-1712. doi: 10.1016/j.socec.2008.05.001
- [19] Wang, C. & Lei, L. (2015). The structure, formation mechanism and corporate response of socially responsible consumption. *Advances in Psychological Science* (07), 1245-1257. doi:10.3724/SP.J.1042.2015.01245
- [20] Xie, R. & An, L. (2020). The influence mechanism of innovative characteristics on new energy vehicle consumers' willingness to adopt: The moderating effect of individual innovation. *Contemporary Economic Science* (5), 113-121. <https://kns.cnki.net/kcms/detail/detail.aspx?dbcode=CJFD&dbname=CJFDLAST2020&filename=DJKX202005011&v=3gGDP7N0mbsNxxWp%25mmd2Fc0wB%25mmd2BX8gyPYGJDX2my9t5qzpoR9j1KJK7KiZES76gmFVR5H> (in Chinese)
- [21] Yau, O.H.M. (1988). Chinese cultural values: Their dimensions and marketing implications. *European Journal of Marketing*, 22(5), 44-57. doi: 10.1108/EUM0000000005285
- [22] Zeithaml, V.A. (1988). Consumer perceptions of price, quality, and value: a means-end model and synthesis of evidence. *Journal of Marketing*, 52(3), 2-22. doi: 10.2307/1251446
- [23] Zeithaml, V.A., Berry, L.L., & Parasuraman, A. (1996). The behavioral consequences of service quality. *Journal of Marketing*, 60(2), 31-46. doi: 10.1177/002224299606000203
- [24] Zhang, A.R., Xu, Z.L. & Yu, X. (2020). A study on the influence of the amount of donation and advertising orientation on consumer response. *Nankai Management Review* (04), 12-24. (in Chinese) https://xueshu.baidu.com/usercenter/paper/show?paperid=1v2h0my0726v0ee04b0g0600wy713534&site=xueshu_se

Research on Credit Mechanism of Electronic Honor Certificate System Based on Blockchain

(Full Paper)

Ying Zhao, School of Public Administration, Sichuan University, China, zhaoying@scu.edu.cn

Jia Li, Shenzhen Branch of China Construction Science and Technology Group Co., Ltd, China

Liang Zhou*, School of Public Administration, Sichuan University, China, zhouliang_bnu@163.com

Aobo Lyu, School of Public Administration, Sichuan University, China, lvaobo1@gmail.com

ABSTRACT

The problem of dishonesty in the workplace has been one of the serious problems in business management practice for a long time, and this phenomenon is especially obvious in the recruitment link of the talent market. In order to effectively solve the problem of false resumes in the current talent market, based on the investigation and analysis of the reasons for talents' dishonesty, a solution of trusted electronic honor certificate system based on blockchain is proposed, and the effectiveness of the model is verified by using game theory analysis method. Thus, it provides a credit guarantee scheme based on blockchain technology for electronic honor certificates and other archives without official credit guarantee, which overcomes the problems of unilateral way dimension and high labor cost faced by traditional background investigation and provides a new approach for solving the problem of resume fraud in the recruitment scene of the talent market.

Keywords: credit mechanism, blockchain, game theory, nonacademic records, electronic certificate

*Corresponding author

INTRODUCTION

Dishonesty in the workplace has long been one of the serious problems in business management practice. Authenticity and accuracy are essential to the effective operation of an organization, but dishonesty (in the form of lying, misrepresentation, and fraud) is still prevalent in organizational life (Leavitt & Sluss, 2017). Among them, the recruitment stage is the hardest hit area of workplace dishonesty with the cases of false resumes (Levashina & Campion, 2009). Especially for nonacademic information such as the honorary certificate, which has no official endorsement, the cost of counterfeiting is low, the identification is difficult, and the harm is great. However, traditional solutions such as background checking have some problems such as incomplete dimension, long time-consuming, and high price. Therefore, this study attempts to apply blockchain technology, which is born to solve the trust problem, to workplace recruitment, and to explore a technology-based solution to the problem of false resume.

Blockchain technology has recently attracted attention as a method of transferring data between participants based on the "distributed ledger" model, which provides completely transparent and non-changing data transaction records (Cai *et al.*, 2018). As a special decentralized distributed database, blockchain uses a chain structure composed in chronological order to store data and ensures that the data in the distributed ledger cannot be tampered with through the combination of multiple technologies (Yuan & Wang, 2016). The core advantage of blockchain is to realize decentralized credit in the distributed system where nodes do not need to trust each other (Miraz, 2017), thus providing a new perspective and solution to the problems of centralized credit, such as low efficiency, security risks, high trust cost, and limited capacity. These features are in part achieved through advanced cryptography, providing a security level greater than any previously known record-keeping system (Hjálmarsson *et al.*, 2018). In conclusion, blockchain technology, as a distributed storage technology that can be maintained by multiple parties and can generate disintermediation trust, can just meet the needs of multi-party authentication for multi-party storage of nonacademic data.

However, the combination of technology and scenario does not mean the end of the research. There is still a large space for us to study between the introduction of blockchain technology and the solution to the problem. Blockchain technology has attracted tremendous attention in both academia and the capital market (Cai *et al.*, 2018). With the vigorous development of blockchain technology in academia and industry, there are too many followers in the application of blockchain. Many scenes that cannot be successfully carried out are trying the blockchain solution as well, which put the promising technology at a tendency of serious froth. This has led people to question the validity of the blockchain project. Although blockchain technology can solve many problems existing in traditional centralized systems, the hype about blockchain has seriously exaggerated the actual ability and the application value of the technology, which may lead to the lack of rational thinking on the application scenarios and the limitations of blockchain technology. Finally, it cannot achieve the purpose of reducing cost and increasing efficiency, but also cause resource waste and efficiency reduction, technical security vulnerabilities, and many other issues. Therefore, it is very important to fully explore the necessity and effectiveness of using blockchain technology before applying it. At present, Swiss blockchain researchers Kurl Wust and Arthur Gervais have proposed a structured model to determine whether a certain scenario is suitable for using blockchain technology and which blockchain is suitable by answering six questions about data storage and

system participants (Wust & Gervais, 2018). However, this qualitative judgment depends on the experience of system developers and cannot directly compare the benefits before and after using blockchain technology. Therefore, based on the perspective of game theory, this study selects the recruitment scenario of the talent market as an example and demonstrates the effectiveness and necessity of using the blockchain system from the perspective of quantitative analysis.

To sum up, this study specifically takes college students and practitioners as the research object and constructs an electronic honor certificate system based on blockchain technology. By recording the honor and experience of college students and practitioners and other nonacademic records, the e-honorary certificate is used to prove the personal qualification of job seekers in the recruitment stage, so as to solve the problem of dishonest resume fraud in the recruitment scene. Moreover, based on the perspective of game theory, this paper demonstrates the feasibility and effectiveness of this scheme by taking the recruitment scenario of the talent market as an example.

LITERATURE REVIEW

At present, most of the researches on the problem of dishonesty are divided into three categories (Ercegovac & Richardson, 2004). One is from the perspective of qualitative research; it analyzes and summarizes the behavior performance, current situation, behavior characteristics, causes, adverse effects and main hazards of talent dishonesty. (Lu, 2011; Klein, 2011) Second, from statistical analysis, empirical analysis is conducted on the current situation and influencing factors of talent dishonesty through questionnaire survey data and puts forward countermeasures and suggestions. (Ma *et al.*, 2007). Third, from the perspective of game theory analysis, (Briggs *et al.*, 2013) based on different game conditions, build a variety of game models among different subjects, deduce the reasons and countermeasures of talents' dishonesty from the perspective of quantitative analysis, and put forward corresponding countermeasures and suggestions according to the game results. However, the existing research, the final proposed solutions are countermeasures and suggestions, and the solutions are more general and less implementable. Therefore, this study will analyze the causes of talent dishonesty from information asymmetry and propose solutions to the e-honor certificate system, to provide feasible solutions for solving talent dishonesty in the talent market recruitment scene.

The research on blockchain at home and abroad started in 2013. After the initial development and exploration stage, countries have successfully carried out the basic research on blockchain technology and blockchain application in diversified scenarios since 2016. There has been an explosive growth of literature, and then the trend of exponential increase. So far, it is still in the period of the rapid development of blockchain. Blockchain is a distributed database comprising records of transactions or digital events that have been executed and shared among participating parties. Each of these transactions is verified by the consensus of a majority of the participants in the system (Casado *et al.*, 2018), thus enabling the creation of a distributed consensus in the digital, online world. Blockchain technology facilitates systems to develop a democratic, open, and scalable digital economy. The characteristics of blockchain technology include superior features such as smart contracts and smart property. Its potential financial applications include private securities, insurance, Internet finance, etc., while its non-financial applications include the Internet of Things, decentralized data storage, notary documents, anti-counterfeit solutions, etc. (Wang *et al.*, 2016).

As far as the research of its application scenarios is concerned, China has done some researches on copyright protection, electronic medical records, academic certification, etc., but there is no research and application exploration in the recruitment scene. Through the project investigation, it is found that there has been some exploration of education and credit certification system based on blockchain technology. What is more well-known at the government level is that the Kenyan government and IBM have cooperated in establishing a diploma network publishing and management platform based on blockchain technology, trying to realize the transparent production, transmission, and inspection of academic certificates. What is more famous at the school level is that Holberton School has cooperated with bit proof to become the first school in the world to use blockchain technology to record academic qualifications. MIT and learning machine software company jointly released block certs, a certificate verification system based on blockchain. However, there are still many deficiencies in the existing solutions to the problem of fake resumes of college students and practitioners in the recruitment scene of the talent market: first, the education certification system based on blockchain is mainly endorsed by the government or universities and other official organizations who issue certificates, and the recorded information type is not comprehensive enough, mainly on the issued degree certificates. At present, xuexin.com and university archives can be verified in China, so there is insufficient power to promote its reform and use similar new systems. However, training experience, internship experience, scholarship, and other non-academic information that can reflect the overall quality of job seekers are not provided with recording and verification services. Therefore, for these honorary certificates, which have no official institutions to provide inspection services but play an important role in personal qualification certification, we should explore how to ensure their authenticity, reliability, and credibility, and the blockchain technology is conducive to guarantee the above. Second, existing research is from news reports. Except for block certs, which provide code download, there is no open-source or system for external members of the organization to access or make use of. Therefore, there is no system that can be directly used and needs independent research and development. However, the block certs issue certificates based on bitcoin lead to the system's poor flexibility and high cost of issuing certificates. Therefore, it is necessary to explore new blockchain technology solutions and independently develop an electronic honorary certificate system that can reduce the cost of issuing certificates and improve the flexibility of the system. Third, most of the current systems only consider the use of a centralized organization scenario and do not consider the needs of multi-center management and cooperation in reality, which leads to the problems of single certificate type, limited use scenarios, and insufficient application value. Therefore, it is necessary to explore how to fully utilize blockchain technology to build an electronic honor certificate system for multi-party cooperation and use.

Based on the above research status, the electronic honorary certificate system based on blockchain technology designed by this research is a certificate storage system that can be maintained by multiple parties and used to record nonacademic honors and experiences. The system integrates the issuance, storage, verification, and use of electronic honorary certificates, and disintermediates trust based on blockchain technology, which is not endorsed by official organizations. Records and verification services are provided for academic, honor, and experience information to meet the needs of personal qualification certification in various scenarios, such as enrollment and job search.

ANALYSIS OF THE REASONS FOR TALENTS' DISHONESTY

In the problem of dishonesty in job hunting, job seekers package themselves falsely to get jobs and favors from enterprises. At present, the dishonest behaviors of college students and practitioners in job hunting are mainly manifested in the following three aspects: first, forging degree certificates. For example, making false academic certificates, forging false scholarships, honorary certificates, and other awards and even certificates not obtained during the University. The second one is a fake experience. They make up their school and in-service positions, make up their social practice and activities, and exaggerate their working ability and achievements. Third, the interview fraud, in the interview process to conceal their own adverse information, do not objectively introduce their own situation, and even provide their own favorable false information, exaggerate their ability and quality. Therefore, in the current recruitment stage, due to the incomplete credit system of college students and practitioners and the limited data dimension, most of the nonacademic records such as honor and experience in students' careers cannot be verified, resulting in serious information asymmetry between job seekers and recruiters.

Information asymmetry will lead to adverse selection problems, forming a market of "bad money drives out good money." In the recruitment process, there are a large number of high-quality job seekers and low-quality job seekers. There is a huge difference. In the recruitment process, the recruiter cannot understand the true level and type of job seekers. Therefore, to obtain better returns, the low ability talents will act misleading through deception and concealment. As both the employment system and social integrity status appear at a low level, the low ability job seeker's fake cost is low. Once the income obtained through the interview is large, the low-level talents are likely to get better returns. They are willing to carry out opportunistic behavior. Simultaneously, to reduce the recruitment risk caused by information asymmetry, the recruiter will try to reduce the salary at the average wage of the talent market. Because the average wage is lower than the expectation of the talents with high ability but higher than the talents with low ability, the high-level talents will very likely put down the less-competitive offer and quit the application, thus leave the low-level talents with higher income; this resulted in the talent market for the appearance as "bad money drives good money."

According to the theory of adverse selection, three conditions need to be met: first, the buyer does not know the real quality of the product or service; second, the cost of the inferior product is lower than that of the high-quality product and has a relative price advantage; third, the inferior product can be disguised as a high-quality product, and the total cost of camouflage is lower than the average market price. In the current recruitment scenario, the above three conditions can be met. First of all, the recruiter does not know each job seeker's true level and ability, so it is difficult to predict the true level and ability of the job seeker due to the impossibility of verifying the authenticity. Secondly, the low ability of talents has a price advantage. Compared with the high ability job seekers, the low ability job seekers have a lower expected salary. The recruiters tend to recruit talents at a lower price, which will make the low ability talents have a certain price advantage. Finally, the low ability talents can disguise themselves as the high ability talents with low cost since the recruiters can hardly figure out what is true and what is false based on non-verified documents. Therefore, in the current situation of information asymmetry between the two sides of recruitment, the cost of dishonesty is low, and the income of dishonesty is high. For their own interests, job seekers take advantage of their own information to damage the interests of the recruiters.

ANALYSIS OF TALENT DISHONESTY SOLUTION BASED ON BLOCKCHAIN

To solve information asymmetry between job seekers and recruiters, the solution proposed in this study is to build a trusted electronic honor certificate system based on blockchain technology. The system is a nonacademic record storage platform, mainly used to record nonacademic honor and experience information without credit endorsement and verification provided by official institutions. It records students' activities and experiences in school and in-service and generates electronic honorary certificates for employers as personal qualification certificates in the recruitment stage. Information transparency can reduce the cheating behavior of job seekers. The advantages of blockchain technology in cost saving have been verified by extensive industry practice (Ko *et al.*, 2018). With the help of blockchain technology, it is expected to solve cumbersome process problems, difficult verification of authenticity, and high hidden cost in verifying students' and practitioners' qualifications, to achieve the goal of eliminating job seekers' fraud.

The system's final implementation needs the participation of the owner, publisher, user, and a platform of the e-honor certificate. The e-honor certificate owner refers to the recipient of honor and experience, mainly the individual user of the guarantor. On the one hand, the guarantor can upload the stock paper certificate obtained before the system goes online to the system, to solve many disadvantages of the paper certificate; on the other hand, he or she can also participate in the activities organized by the issuer in the system to obtain a new e-honor certificate. Publishers refer to the Awarders of honors and experiences and can add honor and experience records for participants by publishing the system's activities. The user refers to the employer who needs to view the honor and experience, such as the colleges and universities at home and abroad, and the recruitment enterprises. The

owner provides the link or two-dimensional code of the electronic honor certificate. The employer can view the honor and experience information stored by the guarantor on the blockchain. The system platform party refers to the third-party organization responsible for its daily operation and maintenance and currently refers to the system developer. As the role of normal operation and maintenance of the system, the platform side deploys a node by default. Other publishers, users, and other participants who can provide computing power can choose whether to act as nodes in the alliance chain according to their needs to maintain the e-honor certificate system jointly.

The e-honor certificate system proposed in this study mainly includes two core business processes: one is the stock chain, which refers to that the guaranteed user uploads the paper certificate obtained before using the system to the system to form the electronic honor certificate, which mainly solves the problems of paper certificate missing, damaging and difficult to transfer. This stage is mainly based on blockchain's technical characteristics, such as the difficulty of tampering and traceability, which makes false information permanently recorded and cannot be deleted. Second, incremental file and certificate chain, which refers to the electronic honor certificate added by the publisher by registering in the system to participate in the activities held by the publisher, to ensure that the whole process of honor or experience generation is open, transparent, and well documented, and the electronic honor certificate is recorded on the blockchain since its birth, to ensure the authenticity and credibility of the incremental honor of the new link from the source. On the one hand, the system can record the guaranteed person's nonacademic record information to play the voucher value in the recruitment process. In this way, the guaranteed person needs to participate in real activities if he wants to obtain the qualification certificate. On the other hand, the students' false resume cannot be proved in the system to crowd out the dishonest job seekers. They have no word of mouth in the talent competition market. Providing a verifiable verification platform for employers can greatly provide the detection probability of job seekers' dishonesty and fraud and deter talents from choosing trustworthy behaviors.

DESIGN OF ELECTRONIC HONORARY CERTIFICATE SYSTEM BASED ON BLOCKCHAIN

According to the usage scenario of the e-honor certificate and the fabric blockchain network's node architecture, the e-honor certificate system's organizational structure is designed, as shown in Figure 1. According to the blockchain application system's characteristics, this system's real roles can be divided into two categories: internal nodes and external application nodes. Internal nodes refer to computing nodes that need to provide computing power to participate in blockchain network management. In contrast, external nodes refer to client nodes that do not participate in blockchain network management and only use applications. The internal nodes of the blockchain network in the figure show the alliance chain composed of the organizations. Each organization contains four types of nodes in the fabric network. All nodes of the three organizations maintain the same certificate account book on the same channel. In the development stage, only the platform side, i.e., the system developer providing computing resources to act as nodes in the alliance chain. In the later stage, with the online and use of the system, organizations that need and can provide computing resources can apply to become computing nodes in the blockchain network. This system's external application node, namely the client node, includes publisher, user, owner, and platform. The issuing party refers to the organization or department that has the power to issue various qualification certificates; the owner refers to the guaranteed person who needs to store certificates of honor or activity experience, mainly college students and practitioners; the user refers to the enterprise or department that needs to measure the comprehensive quality of students according to the certificates; the system platform side refers to the management side of the certificate storage platform. After being authorized by the platform through identity authentication, the publisher and the owner can exercise their rights by calling the corresponding smart contract. After obtaining the owner's authorization, the user can query the user's electronic honor certificate on the blockchain through this platform. In the absence of the platform, the contact between the publisher, the owner, and the user mainly occurs in real life. The circulation is carried out through paper certificate mailing and other ways. The system structure is shown in Figure 1.

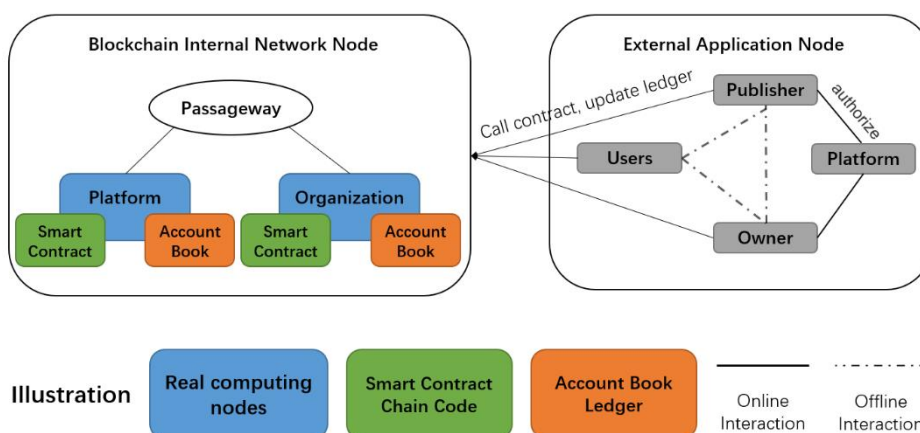

Source: This study.

Figure 1: Organization Chart of E-Honor Certificate System.

This study's e-honor certificate system is divided into three parts: Web application front end, back-end server, and blockchain server. The web application side adopts B / S architecture. Users can use e-honor certificate upload, query, activity distribution, and other services after registering and logging in to the e-honor certificate system through the browser; the back-end server receives and processes the user's request at the application end and calls the MySQL database. Simultaneously, it is necessary to call the fabric's SDK to communicate with the blockchain server for data communication; the blockchain server receives the application side's core business data and completes the consensus by calling the smart contract to perform addition and query operations. After the consensus result is packaged into blocks, it is distributed to each node and written into the blockchain account book to complete the blockchain's data storage. Each node in the alliance chain needs to deploy a blockchain server, and multiple nodes jointly form a distributed blockchain network, the logical architecture of the system is shown in Figure 2.

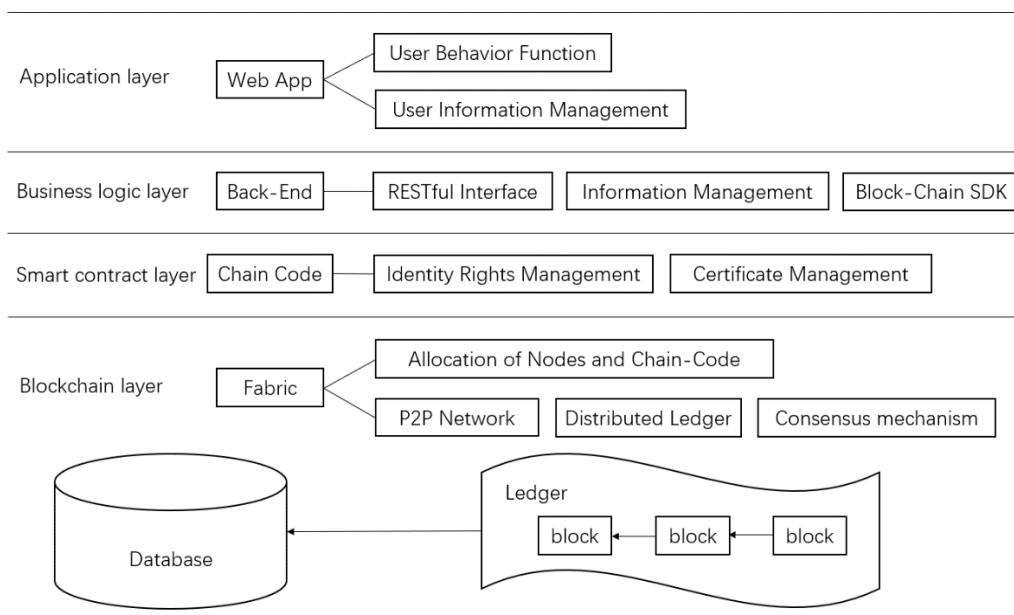

Source: This study.

Figure 2: Logical Architecture of E-Honor Certificate System.

The physical architecture of the system is shown in Figure 3. The system users use the e-honor certificate system through the browser. When using the system's certificate storage and other functions, the system stores the relevant data and files to the local database through the background server. It stores the hash value of the key data and files to the blockchain. In the blockchain network development stage, the system developer provides a peer node, CA node, and sorting node to ensure the normal operation of the blockchain network function.

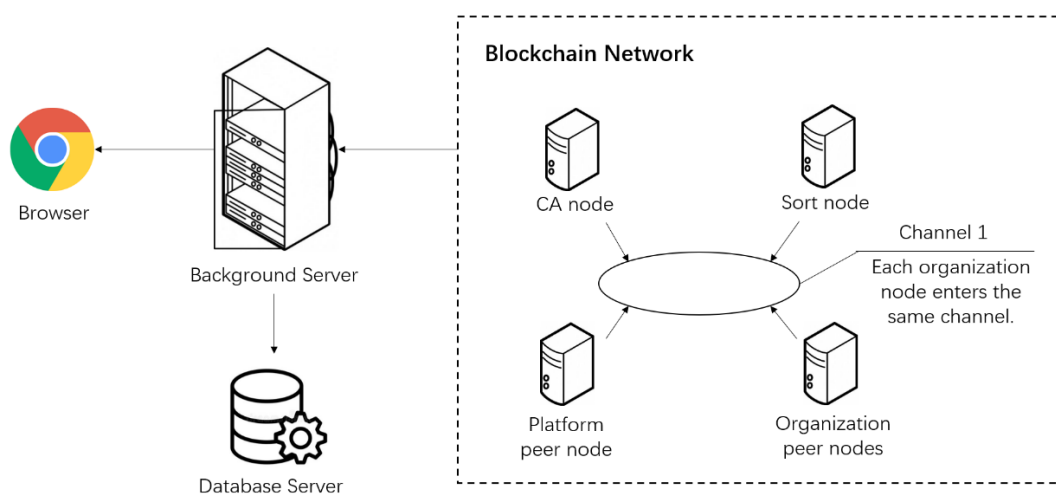

Source: This study.

Figure 3: Physical Architecture of E-Honor Certificate System.

VALIDITY ANALYSIS OF BLOCKCHAIN E-HONOR CERTIFICATE SYSTEM BASED ON GAME THEORY

Due to the information asymmetry in the recruitment process, job seekers and recruiters have a game problem between them to maximize their own utility. As the main body of independent decision-making and rational "economic man" (Grampp, 1948), job seekers will ponder according to the cost-benefit principle in the process of job hunting. In the recruitment process, it is a game process whether a job seeker takes dishonest behavior to fake his honor and experience (Litzenberger, 2002). Job seekers will weigh the utility of keeping faith and breaking faith according to their own utility function and choose their own strategies according to the principle of maximizing the utility of their own behavior. Therefore, from the perspective of game theory, this section will explore the different types of games under different conditions of job seekers and recruiters, analyze the reasons for talent dishonesty through the game model, and explore the impact of the electronic honor certificate system based on blockchain technology on the game conditions and game results. From the perspective of theoretical deduction, the electronic honor certificate system's necessity and effectiveness to solve the problem of fraudulent resumes of talents in recruitment scenarios are explored.

From the perspective of pure strategy Nash equilibrium (Litzenberger, 2002), the recruitment process is abstracted as a scenario where there are only one recruiter and one job seeker. There are two strategies for enterprises, Employment, and Non-employment, and two strategies for talents, Keeping promise and Breaking promise, namely, whether to fake their own experience or reputation. $V1$ represents the trustworthy income of talents, that is, the jobs and salaries obtained under their true abilities; $V2$ represents the income of enterprises' recruiting trustworthy talents, that is, the benefits brought by talents with matching abilities and positions; $-V2$ represents the loss of nonemployment of trustworthy talents; $I1$ represents the dishonest income of talents, that is, the high income obtained by fraud; and $V1 < I1$ represents fraud Job seekers will get more profits. $L2$ represents the loss of dishonest talents employed by enterprises: the loss caused by the recruitment of talents whose ability is not consistent with the position. And $V2 < L2$ means that the loss of employing dishonest talents is greater than that of not employing trustworthy talents. The payment matrix of the model is shown in Table 1.

Table 1: payment matrix without blockchain system.

		Talent	
		Keeping promise	Breaking promise
Enterprise	Employment	$(V2, V1)$	$(-L2, I1)$
	Non employment	$(-V2, 0)$	$(0, 0)$

Source: This study.

The Nash equilibrium of the game is (no employment, dishonesty), and the income is (0, 0). The result is that there will be no contractual agreement between the job seeker and the recruiter, the social benefit is 0, and the human resource cannot be allocated effectively. That is to say, in a game, job seekers have no motivation to keep their promise and only focus on maximizing their immediate interests. Therefore, choosing non-compliance is the strategy of maximizing utility. Similarly, recruiters have no sufficient reason to be sure that job seekers will keep their promise. Therefore, for them, choosing not to hire is a strategy to reduce the risk of recruitment and ensure the maximum utility of the enterprise. Therefore, in a game, because the promise of keeping the promise is not credible, it is impossible to form a set of equilibrium strategies, which makes it difficult to guarantee trustworthy behavior in recruitment.

The model reflects the current reality of recruitment. On the one hand, due to information asymmetry, the cost of personnel fraud is almost zero, which can be ignored. Job seekers can package themselves as high-quality talents in recruitment. However, due to the fact that background investigation needs to consume more human resources and time, it will not conduct background checking on all talents on a large scale at present; On the other hand, due to the incomplete construction of the social credit system, even if fraud is found, the impact on talents is very small, so that the winners and losers will not be punished, and the trustworthy will not be rewarded. On the contrary, due to the cheating of the dishonest, the recruiter will discount the credibility of the trustworthy person, thus damaging the interests of the trustworthy person, and the enthusiasm of the talent to keep his promise is damaged in the end. Those who keep their promise also tend to be fake, forming a vicious circle, which leads to the phenomenon of large-scale falsification of resumes. In the current situation of job seekers' fraud on a large scale, the reason why employment relationships can still occur is mainly that the enterprise undertakes the risk and loss on talents' fraud and still employs job seekers with the possibility of dishonesty. However, this does not form a virtuous circle of talents. When job seekers find that counterfeiting applicants can still be employed and obtain higher income, they will rush for it, thus, opportunistic behavior is promoted. Therefore, in order to break the vicious circle of talents' dishonesty, it is necessary to prevent the dishonesty of talents so as to effectively allocate human resources and solve talents' fraud from the root up.

In order to solve the above problems, this study proposes an electronic honor certificate system based on blockchain. By recording the honors and experiences of talents in school and in-service, on the one hand, it can reduce the information asymmetry between job seekers and recruiters. By recording students' activities and experiences in school, the system can provide more personal information about job seekers and help the recruitment judge the qualification of job seekers, so as to reduce the cost of verification for enterprises to find personnel fraud, expand the scope of talent qualification audit, and facilitate the detection of personnel fraud, so as to punish the dishonest talents such as dismissal, thus deter the counterfeiting behavior of talents; On the other hand, it can increase the cost and difficulty of personnel fraud; Job seekers are no longer just relying on the oral fabrication to package themselves, but they need to participate in activities to acquire the proof of electronic honor certificate,

thus squeezing the dishonest people out of the competitive market. Therefore, this paper takes into account the recruitment game model after introducing an electronic honor certificate system based on blockchain and analyzes the impact and function of the system. Suppose that the model variables after using the blockchain system are shown in Table 2.

Table: 2 model variables.

Job seeker	Recruitment company
V1 income of keeping promise	V2 income of recruiting trustworthy talents -V2 loss of non-recruiting trustworthy talents
I1 dishonest gains	I2 gains from fraud detection
C1 counterfeiting cost	C2 verification cost
L1 dishonest punishment	L2 loss of recruiting dishonest talents
P1 fraud probability	P2 fraud detection probability

Source: This study.

The payment matrix is shown in Table 3. The mixed strategy Nash equilibrium of the model is $P1^* = \frac{C2}{I2+L2}$, $P2^* = \frac{I1-V1-C1}{L1}$. That is, talents choose to fake with probability of $\frac{C2}{I2+L2}$, Enterprises choose to check with the probability of $\frac{I1-V1-C1}{L1}$. The proportion of fake job seekers in the market can also be understood as $\frac{C2}{I2+L2}$. There are $1-\frac{C2}{I2+L2}$ ratio of people chooses not to fake; enterprises randomly check the $\frac{I1-V1-C1}{L1}$ proportion of talent information authenticity.

Table 3: game model after using blockchain system.

		Talent	
		Breaking promise P1	Keeping promise 1-P1
Enterprise	Detecting P2	(I2-C2 , I1-C1-L1)	(V2-C2 , V1)
	Cannot detecting 1-P2	(-L2 , I1-C1)	(V2 , V1)

Source: This study.

It can be seen from $P1^* = \frac{C2}{I2+L2}$ that the probability of dishonesty of talents P1 is an increasing function of variable C2. The higher the verification cost of enterprises, the greater the probability of dishonest behavior of talents. Due to the high cost of enterprise inspection, to reduce the cost, only a small number of key positions are checked, while most of the posts are not checked. Therefore, job seekers will risk more opportunistic behaviors, which will increase the probability of dishonesty. Therefore, reducing the cost of enterprise verification is an important way to solve talent dishonesty. P1 is a minus function of variables I2 and L2. The greater the profit of an enterprise to detect dishonest behavior, the greater the loss of employing dishonest talents is, and the probability of dishonest behavior is smaller. For the enterprise's key positions, such as leadership or management positions, because such positions play important roles, it has a great impact on the decision-making and development of the enterprise. Once the recruitment of talents, whose ability is inconsistent with the position, is caused by fraud, the enterprise will suffer great losses. Therefore, the loss of such dishonest talents is large, and the dishonest talents can obtain greater profits. Reducing the probability of talent's dishonesty will reduce the probability of talent's dishonesty before the investigation. It can be seen that if the background checking can be carried out for all recruitment posts, the information provided by the job seeker will be checked in advance. If false information or honor is found to be false, it will deter talents to a certain extent and make them take trustworthy behavior. This system will provide a convenient and quick platform for employers to check talent information, which can greatly reduce the cost of talent verification, thus making the realization of large-scale background investigation possible. Therefore, the system can reduce the probability of dishonesty P1 of job seekers by reducing the cost of verification C2 and promote talents to take trustworthy behavior.

It can be seen from $P2^* = \frac{I1-V1-C1}{L1}$ that the probability of fraud detection P2 is a minus function of L1, C1, and V1. That is, the greater the punishment for talent dishonesty, the higher the cost of fraud, the higher the income of keeping a promise, and the smaller the probability of enterprise inspection. On the one hand, when the counterfeiting cost and dishonesty punishment are high enough, the increase of fraud difficulty will increase the counterfeiting cost, and the increase of punishment will have a certain deterrent to talents; on the other hand, when increasing the income of keeping a promise, deducting the above losses will greatly reduce the income of dishonesty, and even make the income of dishonesty lower than that of keeping a promise. Therefore, as a rational economic person, job seekers will choose to be trustworthy, reduce fraud so that enterprises reduce the probability of inspection. It can be seen that increasing the cost of counterfeiting and the punishment of dishonesty, at the same time, giving certain rewards to the trustworthy talents and increasing the income of keeping promises, will promote the talents to keep their promise. P2 is an increasing function of I1. That is, the higher the income of talent dishonesty, the greater the probability of enterprise inspection. When the dishonesty can obtain a higher income, the job seeker will choose to make a fraud with a greater probability, and the enterprise will choose to check more. From the above analysis, it can be seen that employers would like to reduce the verification probability P2 for the sake of cost-saving, and the ways to reduce P2 include increasing the fraud cost C1,

the punishment intensity L1 and the trustworthy income V1, and reducing the dishonest income I1. The use of this system can eliminate oral fabrication and packaging by recording the honor and experience of job seekers in school and in-service. High false cost, by recording the dishonest behavior of talents in the chain, dishonest behavior of talents will not only be punished by the current enterprise, but also be punished by the future enterprise not to be employed, to increase the punishment intensity L1, and improve the credibility income of talents by providing privileged services for long-term trustworthy talents, to achieve the purpose of reducing the enterprise verification probability.

From the above analysis, it can be seen that in the case of an imperfect social integrity system, on the one hand, it is impossible to record the historical behavior of talents truthfully, which greatly reduces the cost and difficulty of job seekers' counterfeiting, so that job seekers can make up their past honors and experiences, while the recruiters have no evidence to check and cannot verify; on the other hand, the dishonest behaviors of talents cannot be recorded. It reduces the punishment of dishonesty, not deterring job seekers, but also damages the interests of the trustworthy. The electronic honorary certificate system based on blockchain developed by the research institute can record the nonacademic honor and experience talents so that all resumes can be traced and documented. On the one hand, it increases the cost and difficulty of counterfeiting. On the other hand, by reducing the verification cost of enterprises and reducing the probability of dishonesty, job seekers who apply for any ordinary post can use the system to issue certificates of honor and experience and can conduct a wide range of verification for ordinary posts, to deter the fraud of talents and greatly reduce the probability of dishonesty.

CONCLUSION

Given the practical pain point of dishonest resume fraud existing in the current recruitment scene of the talent market, on the one hand, this paper proposes a solution of electronic honor certificate storage system based on blockchain technology and designs a trusted electronic honor certificate system based on the characteristics of blockchain technology, such as disintermediation trust, multi-party maintenance, and hard to tamper with. The electronic honor certificate records the nonacademic honor and experience information obtained by students in school and in-service. It is used as a personal qualification certificate in the recruitment process. It can reduce the information asymmetry between the recruitment parties, increase the cost of fraud, increase the difficulty of fraud, and increase the punishment and risk of dishonesty, to deter talents from taking trustworthy behavior. The blockchain system solves the two difficulties of the nonacademic record storage system. Firstly, there are many kinds of nonacademic records. The sources are different, so it needs multi-party information exchange; secondly, public credit institutions' lack of endorsement makes it difficult to verify nonacademic records.

On the other hand, based on game theory, we dive deep to analyze the changes in the game environment brought by the blockchain system and then demonstrate the effectiveness and necessity of using blockchain technology in the talent market recruitment scenario. Through quantitative analysis to explore the applicability of blockchain technology in the project, we can compare the benefits brought by the use of blockchain technology directly and objectively analyze the principle of the role of blockchain technology from the theoretical level.

Although this research has carried on a thorough analysis of the talent dishonesty problem in the recruitment scene through the static game analysis, it proposed a solution to construct the electronic honor certificate system. However, with the further extension of the recruitment scene in the talent market, it is necessary to further analyze from the perspective of the dynamic game when it comes to dishonest behaviors such as breaking the contract after signing a contract, not hiring or concealing information by the recruiter, and even extending to multiple social recruitment scenarios in the whole working life of talents, to encourage job seekers and recruiters to take trustworthy behaviors from the beginning to the end. Therefore, in the next stage of the study, the game decision-making order conditions will be added to the game model deduction to further explore the recruitment game of the whole working life of talents from the perspective of the dynamic game (Myerson, 2013), further to improve the recognition and credibility of electronic honorary certificates.

ACKNOWLEDGMENT

This paper is supported by the Soft Science Project Fund of Sichuan Provincial Department of Science and Technology, "Research on the scheme and path of block chain technology helping Sichuan's" Profound Innovation and Reform " (2018zr0366)

REFERENCES

- [1] Briggs, K., Workman Jr, J. P., & York, A. S. (2013). Collaborating to cheat: A game theoretic exploration of academic dishonesty in teams. *Academy of Management Learning & Education*, 12(1), 4-17.
- [2] Cai, W., Wang, Z., Ernst, J. B., Hong, Z., Feng, C., & Leung, V. C. (2018). Decentralized applications: The blockchain-empowered software system. *IEEE Access*, 6, 53019-53033.
- [3] Casado-Vara, R., Prieto, J., & Corchado, J. M. (2018, June). How blockchain could improve fraud detection in power distribution grid. In *The 13th International Conference on Soft Computing Models in Industrial and Environmental Applications* (pp. 67-76). Springer, Cham.
- [4] Ercegovac, Z., & Richardson, J. V. (2004). Academic dishonesty, plagiarism included, in the digital age: A literature review. *College & Research Libraries*, 65(4), 301-318.
- [5] Grampp, W. D. (1948). Adam Smith and the economic man. *Journal of Political Economy*, 56(4), 315-336.
- [6] Hjalmarsson, F. P., Hreiðarsson, G. K., Hamdaqa, M., & Hjalmtýsson, G. (2018, July). Blockchain-based e-voting system. In *2018 IEEE 11th International Conference on Cloud Computing (CLOUD)* (pp. 983-986). IEEE.

- [7] Klein, D. (2011). Why learners choose plagiarism: A review of literature. *Interdisciplinary Journal of e-learning and learning objects*, 7(1), 97-110.
- [8] Ko, T., Lee, J., & Ryu, D. (2018). Blockchain technology and manufacturing industry: Real-time transparency and cost savings. *Sustainability*, 10(11), 4274.
- [9] Leavitt, K., & Sluss, D. M. (2017). Workplace Dishonesty and Deception as Socially Situated Organizational Behavior. In Oxford Research Encyclopedia of Business and Management. <https://doi.org/10.1093/acrefore/9780190224851.013.122>
- [10] Levashina, J., & Campion, M. A. (2009). Expected practices in background checking: Review of the human resource management literature. *Employee Responsibilities and Rights Journal*, 21(3), 231-249.
- [11] Lu, Z.G. (2011). Contemporary College Students' Honesty Analysis and Countermeasures. *Journal of Xuzhou Normal University (Educational Sciences Edition)*, (2), 8. http://en.cnki.com.cn/Article_en/CJFDTotat-XZSJ201102008.htm
- [12] Ma, H., Lu, E. Y., Turner, S., & Wan, G. (2007). An empirical investigation of digital cheating and plagiarism among middle school students. *American Secondary Education*, 69-82.
- [13] Miraz, M. H. (2017). Blockchain: technology fundamentals of the trust machine. Machine Lawyering, Chinese University of Hong Kong, 23rd December.
- [14] Myerson, R. B. (2013). *Game Theory*. Harvard University Press, Cambridge, MA.
- [15] Ritzberger, K. (2002). *Foundations of non-cooperative game theory*. OUP Catalogue, Oxford University Press, number 9780199247868.
- [16] Wang, H., Chen, K., & Xu, D. (2016). A maturity model for blockchain adoption. *Financial Innovation*, 2(1), 12. <https://doi.org/10.1186/s40854-016-0031-z>
- [17] Wüst, K., & Gervais, A. (2018, June). Do you need a blockchain? In *2018 Crypto Valley Conference on Blockchain Technology (CVCBT)* (pp. 45-54). IEEE.
- [18] Yuan, Y. & Wang, F.Y. (2016). Development status and Prospect of blockchain technology. *Acta Automatica Sinica* (04), 481-494. doi: 10.16383/j.aas.2016.c160158

Research on Customer Classification and Service Quality Evaluation of Online Education Platform

(Full Paper)

Jinjing Li, Sichuan University, China, JinjingLi_edu@163.com

Yongzhong Yang*, Sichuan University, China, yangyongzhong116@163.com

Baibokonov Doszhan, Sichuan University, Kazakhstan, d.baibokenov@gmail.com

ABSTRACT

At present, the online education platform is developing rapidly, and effectively identifying the personalized needs of consumers and improving the service experience of consumers is the key element for the online education platform to obtain competitive advantage. In this paper, RFM model is introduced to analyze the characteristics of eight kinds of customer consumption behavior in online education platform, which provides a new idea for consumer segmentation of online education platform. In addition, the improved SERVQUAL scale is used to measure the service quality evaluation of online education platform, and the scores of each evaluation index are calculated by factor analysis and fuzzy evaluation method. Finally, the IPA evaluation model is constructed for different types of customers, in order to explore the personalized service needs of online education platform consumers, and to provide more accurate service marketing countermeasures for enterprises

Keywords: Customer classification, RFM model, SERVQUAL, fuzzy evaluation method, IPA.

*Corresponding author

INTRODUCTION

With the development of information technology, online education platform is gradually rising, and contains huge customer traffic, has become the main source of profit for many websites. However, at present, most of the online education transfers the traditional learning evaluation to the online platform, and simply faces the learning results, so it can not realize the individualized evaluation of "teaching students according to their aptitude", and it is difficult to fundamentally maintain the learners' learning motivation and stimulate their internal driving force. In online education, high quality learning support service is the key to improve the level of online education service and ensure the quality of online education. (Lee, 2010) the separation of time and space between teachers and learners in online education, how to help learners better adapt to the online education environment and ensure the learning effect, is a difficult problem to be solved in online education. With the rapid development of information technology, online education has more and more prominent embodiment of the "learner-centered" teaching concept. (Chen et al., 2016) this concept is actually a kind of personalized learning for customers. According to the different categories of customers, combined with the characteristics of online platform quality of service, it is helpful to fully tap the learning potential of learners. For teachers and managers, how to provide customers with convenience, accessibility, instant, targeted online education and learning services is one of the key factors to improve the quality of online education. Effective, personalized high-quality student support services need to be based on a full understanding of the relevant platform customer information on the basis of (Wei & Chou, 2020). This requires that the network open course in the process of providing learning support services, accurately identify the characteristics of different customer service quality, and provide them with personalized services suitable for themselves.

LITERATURE REVIEWS

Customer Classification

Customer classification can make enterprises better identify the real needs of customers. This paper uses customer value to identify customer types. This study summarizes the current classification of customer value in related fields, and the methods of customer classification also show different ways. (Zhang & Dai, 2020) introduces an interpretable method of customer classification based on genetic algorithm and multi-decision tree. (Piao & Ryu, 2017) A method based on local features is used to classify customers by detecting the local geometric pattern of load map and determining the load shape factor from the actual consumption data. (Zhao, 2019) applies a classification algorithm to customer relationship management system. Hotel management relationship is a good hotel management strategy, which can promote the development of hotel. (Khalili-Damghani *et al.*, 2019) A two-stage clustering classification model is proposed to determine the insurance coverage suitable for customers. This paper will also use cluster analysis to classify customers.

RFM Model

In 1998, the American Institute of Database Marketing put forward the RFM model for the first time, which was originally mainly used in direct marketing (Marcus, 1998); the core idea of the model consists of three variables, namely, the customer's most recent purchase time, the purchase frequency, and the purchase amount. RFM has been used in many ways, not to evaluate the value of the model from a customer's point of view, but to measure pattern rating directly by considering RFM characteristics (Hu & Yeh, 2014). Instead of evaluating the value of the model from a customer's point of view, it measures the

model rating directly by considering the RFM feature. Zhang *et al.* (2015) make significant changes to the implementation in conjunction with the customer life cycle value (CLV): from RFM to RFMC. The application of (RFM) method to predict customer bankruptcy is proposed by using the telecommunications data corresponding to the delayed payment RFM (Zabkowski, 2016). RFM model has been widely used. This paper studies the classification of online education platform customers based on RFM model. In this paper, information is collected through questionnaires. The basic information of consumers is mainly collected through RFM model, which consists of total amount of consumption, time interval and purchase times.

Table 1: RFM model definitions

Dimensiona	Definition
R(recency)	Online education platform customers last purchase time
F(frequency)	Frequency of purchases by online education platform customers over a period of time
M(monetary)	Total amount of consumer spending on online education platforms

Study on Service Quality

PZB proposed a scale method to measure the quality of service in 1988. The quantitative quality of service model is constructed according to the SERVQUAL scale, which mainly includes five characteristics, and has been widely used in the study of quality of service. Altuntas *et al.* (2020) conduct a survey based on SERVQUAL scale to obtain the degree of dissatisfaction of patients with the five main criteria, namely, materiality, reliability, responsiveness, assurance and empathy. Alcura *et al.* (2020) suggest the quality of service in the transport system is determined mainly by evaluating the attitude of passengers. Demir *et al.* (2020) use SERVQUAL scale to investigate occupational health and safety activities from five dimensions: materiality, reliability, responsiveness, assurance and empathy. It can help employers better understand the occupational health and safety services they need to know. SERVQUAL model has been widely used in the research. This paper will also improve the quality of service model according to the characteristics of e-commerce platform. Consumers' evaluation of the online education platform was mainly collected by using the improved SERVQUAL scale structure. On the basis of the original five dimensions, this paper adds the service quality index of the online education platform of experience and ease of use. Finally, the service quality measurement scale of this paper is composed of six dimensions of service quality of online education platform: empathy, tangibility, assurance, responsiveness, experience and reliability.

Based on recent studies at home and abroad, we can find that: (1) In terms of customer classification, customer classification has been used in many fields, and can effectively understand the needs of different customers, so as to provide reference for business managers; and current research on customer classification Most of them have homogeneity and integrity, but in fact, customer types can be subdivided. (2) In terms of service quality, with the continuous development and growth of online education platforms, there are currently most studies on online education, but there are relatively few studies on the service quality of online education platforms; among them, the research on online education platforms is based on the platform Focus on business content, pay less attention to service quality, and traditional service quality models are difficult to predict the true needs of customers, so it is impossible to know the true attitudes of customers to online education platform services, so it is difficult to get rid of blindness with corresponding improvement suggestions Sex.

Therefore, this article will make the following improvements to the research on customer classification and service quality: This article integrates multidisciplinary perspectives and innovatively proposes the "RK-SEF-IPA" research model, with the intention of achieving the scientific nature of customer classification and the objectivity of customer evaluation. And the effectiveness and pertinence of classification evaluation. (1) For customer classification, the introduction of the RFM model can provide references for online education platform organizers to conduct customer classification research, and provide guidance for dynamically supervising the learning process of customers and increasing customer participation in courses. (2) Since the traditional service quality model is not suitable for the development characteristics of online education platforms, this paper uses the improved SERVQUAL model to study the service quality of online education platforms and provide practical management suggestions for online education platform services. (3) Customer classification and platform service quality research are both important factors in the development of online education platforms. Therefore, this paper introduces fuzzy comprehensive evaluation method and IPA model to combine customer classification and online education platform service quality to conduct research, targeting different customer categories Combining with the corresponding service quality evaluation model, it deeply explores the customers of online education platform, and explores the characteristics of different types of customers and their service quality evaluation.

RESEARCH DESIGN

Research Model Construction

In this paper, through the review and summary of the relevant literature at home and abroad and combined with the characteristics of the online education platform, the "RK-SEF-IPA" model is constructed, as shown in figure1. First of all, the RFM model and K-Means clustering method are combined to divide the customer types of online education platform; secondly, the improved SERVQUAL scale is used to measure the service quality evaluation, and combined with factor analysis and fuzzy evaluation method to calculate the scores of each evaluation index; finally, the IPA evaluation model is constructed for different types of customers, and the quality of service is comprehensively evaluated through the importance and performance scores.

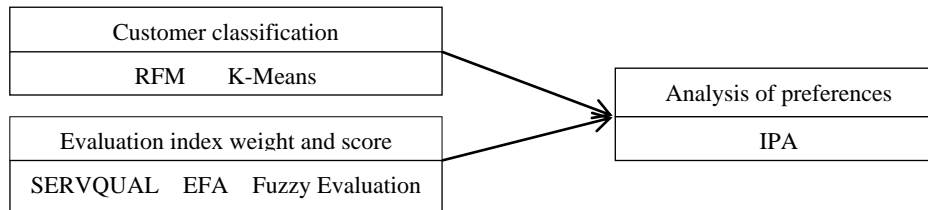

Figure 1: "RK-SEF-IPA" research model

Questionnaire Design

This questionnaire is mainly divided into three parts. The first part is a survey on the basic consumption of online education platform customers, including the platform's recency, frequency, and money; the second part is a survey on the importance of improving the SERVQUAL model characteristics to consumers, from usability, Reliability, Empathy, and Assurance, Responsiveness, experimental, Tangible.

Seven dimensions are measured. The third part is a survey of consumer basic information. In this paper, through a combination of online and offline methods, a total of 312 questionnaires were issued and 300 questionnaires were returned. The total questionnaire recovery rate was 96.15%, and 34 unqualified questionnaires such as missing and incorrect fillings were excluded. There were 266 valid questionnaires in total. The efficiency is 88.66%. A total of 266 questionnaires were finally used for data analysis.

Table 2: Descriptive statistical analysis

Demographic variables	Categorical variables	Frequency	frequency(%)	Cumulative percentage (%)
Gender	male	105	39.5	39.5
	Female	161	60.5	100
age	Under 18	35	13.2	13.2
	18-24	139	52.3	65.4
	25-34	34	12.8	78.2
	35-44	39	14.7	92.9
	45-54	16	6.0	98.9
	Over 54 years old	3	1.1	100.0
monthly income	Under 1000	83	31.2	31.2
	1001-2500	63	23.7	54.9
	2501-5000	56	21.1	75.9
	5001-10000	45	16.9	92.9
	Above 10000	19	7.1	100.0
Profession	State-owned enterprise employees	30	11.3	11.3
	Government officials	9	3.4	14.7
	Institutional employees	26	9.8	24.4
	Foreign investment or joint venture	9	3.4	27.8
	Private company employees	12	4.5	32.3
	Self-employed	28	10.5	42.9
	Freelancer	23	8.6	51.5
	student	121	45.5	97.0
	Retirees	3	1.1	98.1
Farming	5	1.9	100.0	

EMPIRICAL ANALYSIS

Customer Value Analysis

Analysis of Customer RFM

Use SPSS to draw the RFM box counting chart based on customer data, as shown in Figure 2: (1) Customer data is more evenly distributed. (2) The number of customers with high purchase frequency and high scores is small. (3) The total amount of consumption is mainly concentrated in 3 or 4 points, indicating that there are more customers whose total consumption amount is about the average. (4) Customer consumption time is mainly concentrated in high scores, which reflects that the customer's last consumption time is longer and the interval is large.

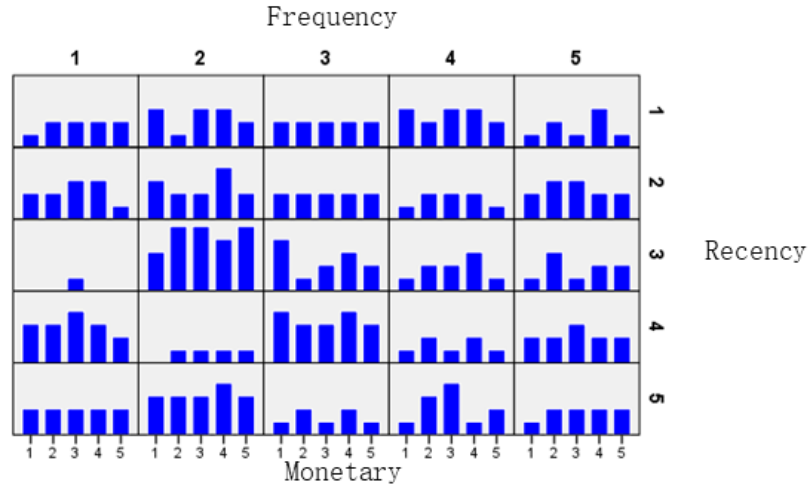

Figure 2: RFM count table.

Customer Value Analysis

According to the data obtained from the survey, the three indicators of the online education platform's consumption time interval, the number of consumptions of the customer, and the total amount of consumption of the customer are obtained. In addition, a descriptive analysis of the online education platform customer consumption frequency score, consumption time interval score, and consumption amount score distribution was performed, and the average value of the time interval, the number of purchases, and the total consumption amount of 282 customers were obtained, as shown in Table 3. Show: The average time interval is 3.01, the average purchase frequency of online education platform customers is 2.95, and the average total consumption amount of platform customers is 3.02.

Table 3: Descriptive analysis of R-F-M score

	N	Min	max	Mean	Std
recency	266	1	5	3.01	1.412
frequency	266	1	5	2.95	1.366
monetary	266	1	5	3.02	1.356
Valid N (list status)	266				

Then, through the recoding function of SPSS to realize the classification of customer types, the dividing points of time interval, number of purchases, and total consumption amount are 3.01, 2.95 and 3.02 respectively. Since the original data cannot meet the requirements of data analysis, it is necessary to appropriately convert the original data and perform logarithmic conversion to obtain standardized data. Then according to the K-Means clustering analysis algorithm, the R, F, and M indicators in each cluster are compared with the indicators of the overall average value of the overall R, F, and M, and the number of clusters is set to 8. Among them, three indicators of R, F, and M are tested by ANOVA analysis of variance, and the significance index Sig.<0.05 is obtained, which proves that the difference of R, F, and M is extremely significant, which is suitable for cluster analysis. Carry out cluster analysis of customer value and use the average value as the criterion for dividing high and low.

Table 4: Basis for classification of customer types

R	F	M	Customer type coding	Customer type
R↑	F↑	M↑	1	High value customer
R↓	F↑	M↑	2	Focus on maintaining customers
R↑	F↓	M↑	3	Focus on the development of customers
R↓	F↓	M↑	4	Focus on retaining customers
R↑	F↑	M↓	5	General value customer
R↓	F↑	M↓	6	Generally keep customers
R↑	F↓	M↓	7	General development of customers
R↓	F↓	M↓	8	Potential customer

In order to combine customer classification with service quality better, eight customer categories are divided into "key customers" and "general customers".

Table 5: Customer Value Classification

First-class classification	Secondary classification	Number of customers	Total customer quantity
Key customers	High value customer	24	107
	Focus on keeping customers	37	
	Focus on developing customers	18	
	Focus on retaining customers	28	
General customers	General value customer	38	159
	Generally keep customers	54	
	General development customers	27	
	potential customers	40	

Service quality research

Through the above classification of online education platform customers, more clear the characteristics of each customer, customer in the platform service quality evaluation, study the service quality gap of each type of customers.

Reliability analysis

The empirical analysis uses Cronbach's Alpha structural validity test to analyze the reliability and validity of the questionnaire data to further explore the rationality of the data.

Table 6: Reliability test

Survey scale	Number of Cronbach's Alpha	terms
Materiality	0.847	4
Guarantee nature	0.792	5
Empathy	0.891	5
Responsiveness	0.890	5
Experiential	0.815	4
Ease of use	0.991	6

KMO and sphere tests were performed on the obtained data, and the results were shown in Table 7. The KMO value of the sample is 0.945, and the correlation degree between the items is good, which is suitable for analysis.

Table 7: KMO and Bartlett tests

KMO and Bartlett test		
A sufficient Kaiser-Meyer-Olkin measure for sampling.		.945
Spherical degree Test of Bartlett	Approximate chi-square	7568.606
	Df	528
	Sig.	.000

In this paper, the cumulative interpretation ability of common factors extracted in factor analysis is more than 70%, and the load of each item in the questionnaire is more than 0.6. The scale has good structural validity.

Secondly, the principal component method is used to extract the service quality factors of the online education platform, and the main components of the online education platform are extracted according to the principle that the characteristic value is greater than 1. The items with less than 0.6 factor loads are eliminated, and six common factors are extracted. The results show that the shape, assurance, responsiveness, reliability, empathy and experience are all the main factors that constitute the service quality of the online education platform.

Table 8: Rotating Component Matrix

Topic	1	2	3	4	5	6
Q1 platform teachers dress neatly and appropriately	.754	.420	-.022	.230	-.007	.329
Q2 the smooth progress of consumption process	.706	.344	.243	.247	-.125	.016
Q3 platform has modern service facilities	.760	.047	.147	.279	-.011	-.021
Q4 Attractive service facilities of platform	.698	.091	.144	.274	.053	.044
Q5 platform is very specific and comprehensive	.138	.064	.290	.026	.817	.010
Q6All the information displayed on platform is true	.161	.173	.575	.097	.691	-.035
Q7 solve the problems encountered by users	.209	.174	.589	.063	.766	.050
Q8 platform puts the interests of customers first	.138	.027	.673	.059	.368	.116
Q9 platform has personalized service for users	.102	.194	.659	.062	.066	-.007
Q10 platform cares about users' learning from time to time	.240	.117	.672	.490	.043	.148
Q11 patiently answer questions raised by users	.147	.134	.640	.552	.069	-.050
Q12 platform teachers are polite and friendly	.014	.814	.188	.539	.010	.229
Q13 platform teachers is worthy of users' trust	.254	.758	.191	.579	.039	-.075
Q14 users feel at ease during the course.	.110	.760	.064	.585	.068	-.156
Q15 fast response to pre-sales consulting services	.132	.556	.093	.847	.031	.081
Q16 response speed service on this platform is fast	.162	.037	.014	.823	.245	-.355
Q17 online education courses in a timely manner	.242	.178	.011	.835	.056	.134
Q18 platform is efficient in dealing with user problems	.131	.066	.155	.802	.034	-.119
Q19 platform products are novel and interesting	.136	.210	.185	.084	-.024	.852
Q20 There is teaching interaction with users	.297	.173	.281	.077	.019	.861
Q21 platform has offline experience activities about products	.379	.122	.089	.015	.008	.828

Fuzzy comprehensive evaluation

First, determine the Fuzzy comprehensive evaluation factor set. The target layer and criterion layer of the online education platform service quality evaluation index system are expressed as:

Target layer:
$$U = (U_1, U_2, U_3, U_4, U_5)$$

Criteria layer:

$$U_1 = (U_{11}, U_{12}, U_{13}, U_{14}, U_{15}, U_{16})$$

$$U_2 = (U_{21}, U_{22}, U_{23}, U_{24})$$

$$U_3 = (U_{31}, U_{32}, U_{33}, U_{34}, U_{35}, U_{36})$$

$$U_4 = (U_{41}, U_{42}, U_{43}, U_{44}, U_{45})$$

$$U_5 = (U_{51}, U_{52}, U_{53}, U_{54}, U_{55})$$

In this model, the evaluation set is:

$$(E = E_1, E_2, E_3, E_4, E_5, E_6) = \{\text{Very unimportant, important, average, not important, very unimportant}\}$$

Third, determine the weights of the criterion layer and the index layer. In order to avoid the subjective errors that may be caused by the traditional expert estimation method, this study uses a more objective factor analysis to determine the weight of the online education platform service quality evaluation indicators. The index weight of the criterion layer is the ratio of the variance contribution rate to the cumulative variance contribution rate, and the index weight is the ratio of the index factor load to the sum of the dimension factor load.

Table 9: Evaluation of Importance and Expressive of the index layer

First level indicator	Importance	Expressive	index	Importance	Expressive
QA1 Tangible	0.492	3.995	Q1	0.126	0.935766
			Q2	0.157	1.183527
			Q3	0.127	0.979160
			Q4	0.118	0.896728
QA2 Assurance	0.213	4.126	Q5	0.074	1.467894
			Q6	0.069	1.329428
			Q7	0.069	1.329250
QA3 Empathy	0.112	3.726	Q8	0.028	0.937692
			Q9	0.027	0.902538
			Q10	0.028	0.946150
			Q11	0.027	0.939686
QA4 Responsiveness	0.079	3.814	Q12	0.020	0.974848
			Q13	0.019	0.911648
			Q14	0.019	0.994644
			Q15	0.019	0.933394
QA5 experiential	0.058	4.201	Q16	0.021	1.534366
			Q17	0.017	1.243815
			Q18	0.019	1.423296
QA6 Reliability	0.042	3.984	Q19	0.014	1.392595
			Q20	0.014	1.379716
			Q21	0.013	1.296100

The fuzzy comprehensive evaluation value of the evaluation criterion layer, and the Expressive and other factors of the scale are shown in Table 4. According to the survey sample of this questionnaire, the experimental performance has the largest proportion, which proves that the platform has the highest degree of performance in the actual perception of consumers, and the performance of Empathy is the lowest. It proves that the degree of effort of the Empathy platform is lower in the actual perception of consumers. low.

Customer Classification Evaluation

According to the customer classification obtained by the RFM above, two categories of "general customers" and "key customers" are obtained. Since the index weight of the Importance criterion layer is the ratio of the variance contribution rate to the cumulative variance contribution rate, the index weight is the index factor load Compared with the sum of the factor loads of this dimension, factor analysis requires an overall analysis of the questionnaire sample data, so the Importance index value needs to be set as the control variable, and the Expressive index is categorized. Under Importance, where customers believe that the service quality of online platforms is the same, different types of customers have different perceptions of online education platforms, as shown in Table10. The "key customers" of online education platforms believe that Assurance is the highest factor in the actual perception of the platform, and the platform has a better performance in this factor, and the performance of Responsiveness is the lowest. "General customers" consider Assurance the highest level of performance and Empathy the lowest level. Both "general customers" and "key customers" believe that the online education platform Assurance has the highest level of performance, and the actual platform perception of "general customers" is generally higher than that of "key customers". As shown in Figures 3 and 4.

Table 10: Performance classification

First level indicator	Importance	index	Expressive (Criterion layer)		Expressive(factor)	
			Focus customer	general customer	Focus customer	general customer
QA1 Tangible	0.492	Q1	3.950	4.063	0.908676	0.976530
		Q2			1.193157	1.170045
		Q3			0.965900	0.998660
		Q4			0.882388	0.918238
QA2 Assurance	0.213	Q5	4.202	4.213	1.490230	1.493720
		Q6			1.332688	1.346706
		Q7			1.379625	1.372800
QA3 Empathy	0.112	Q8	3.824	3.730	0.992984	0.930384
		Q9			0.910442	0.890929
		Q10			0.986498	0.961390
		Q11			0.954604	0.947672
QA4 Responsiveness		Q12	3.716	3.822	0.927408	0.971264

	0.079	Q13	4.105	4.143	0.912392	0.915864
		Q14			0.995400	0.993888
		Q15			0.908312	0.940896
QA5 experiential	0.058	Q16	3.974	4.211	1.501338	1.523237
		Q17			1.236846	1.234725
		Q18			1.367184	1.384656
QA6 Reliability	0.042	Q19			1.367470	1.430785
		Q20			1.339156	1.440556
		Q21			1.267175	1.339325

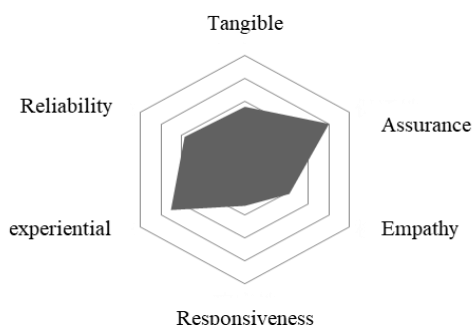

Figure 3: Expressive evaluation of key customers

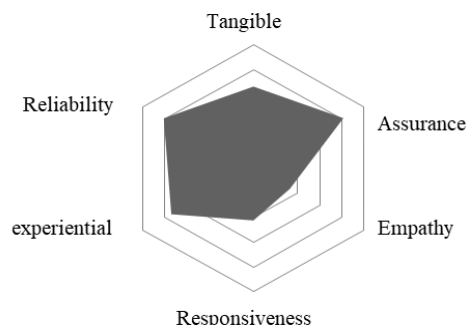

Figure 4: Expressive evaluation of general customers

DEVELOPMENT STRATEGY AND RECOMMENDATIONS

IPA Analysis

On the basis of fuzzy comprehensive evaluation, in order to further help the online education platform, determine the priority of service quality improvement, the material-performance (IPA) method is adopted to analyze the importance and performance degree of each indicator, and provide theoretical basis for the improvement of the online education platform.

Based on the value of online education platform for the Y axis, expressive, with the weight of each dimension for the X axis, the importance of dimensions to the average of the evaluation value and weight as the coordinate origin, will coordinate chart is divided into I, II, III, IV quadrants. The IPA method was used to analyze the scores of the online education platform, and the two-dimensional scatter distribution map of the six-dimensional IPA of the online education platform was drawn, and four quadrants were obtained with different characteristics.

Customer IPA Analysis

The IPA models of “key customers” and “general customers” are compared and analyzed above. In order to better improve the service quality of the online education platform, the overall service quality of the overall customer service quality will be evaluated after fuzzy evaluation of the overall service quality scale. The six-dimensional IPA analysis is shown in Figure 5.

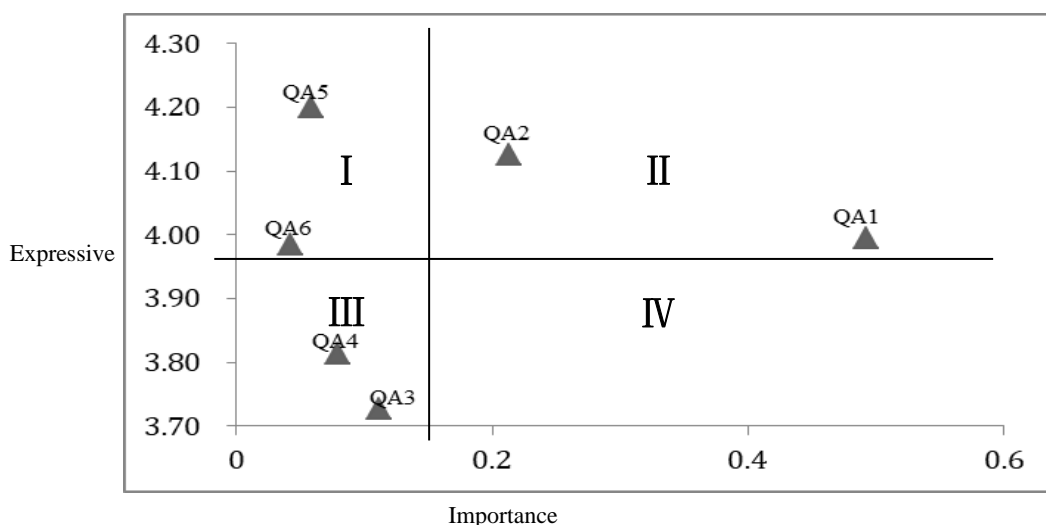

Figure 5: Six-dimensional IPA analysis of overall service quality.

In the above research, the six dimensions' present different distribution trends. Experience and reliability are in the first quadrant, tangibility and assurance are in the second quadrant, empathy and responsiveness are in the third quadrant, and there are no indicators in the fourth quadrant. Into. Tangibility in the IPA matrix, tangibility is located in the second quadrant, which indicates that customers pay more attention to it, and the expressiveness is also higher, which belongs to the continued maintenance area. It proves that the physical facilities of the platform are relatively complete and well developed. You can continue to improve when resources are sufficient. Assurance is located in the second quadrant, performance and importance are relatively high, and it belongs to the continued development area. Empathy is located in the third quadrant in the IPA matrix, indicating that the platform's expressiveness is low and its importance is relatively low, which is an area of improvement. The responsiveness is located in the third quadrant. The indicators in this quadrant are characterized by low importance and low evaluation value. Explain that the platform cannot quickly respond to customer requests, deal with platform suggestions or complaints, and feedback platform processing information. Experience is located in the first quadrant. The characteristics of the indicators in this quadrant are that customers do not pay much attention to it and the service quality evaluation score is high. Reliability is located in the first quadrant, and the indicators belonging to this quadrant are characterized by high importance and high evaluation. It shows that customers have a high perception of the reliability of the platform, and its performance is also high. Reliability is the basis for the online education platform to gain customer trust, so it needs to continue to improve.

The improvement of service quality needs to be accurate to the dimensions. The IPA analysis method is used to conduct an in-depth analysis of the service quality subdivision indicators of the online education platform. The average value of 21 subdivision evaluation indicators Importance (0.048) and Expressive (1.139) are respectively taken as Referring to the dividing line, draw a two-dimensional scatter point distribution map of the refined indicators of the online education platform service quality, as shown in Figure 6.

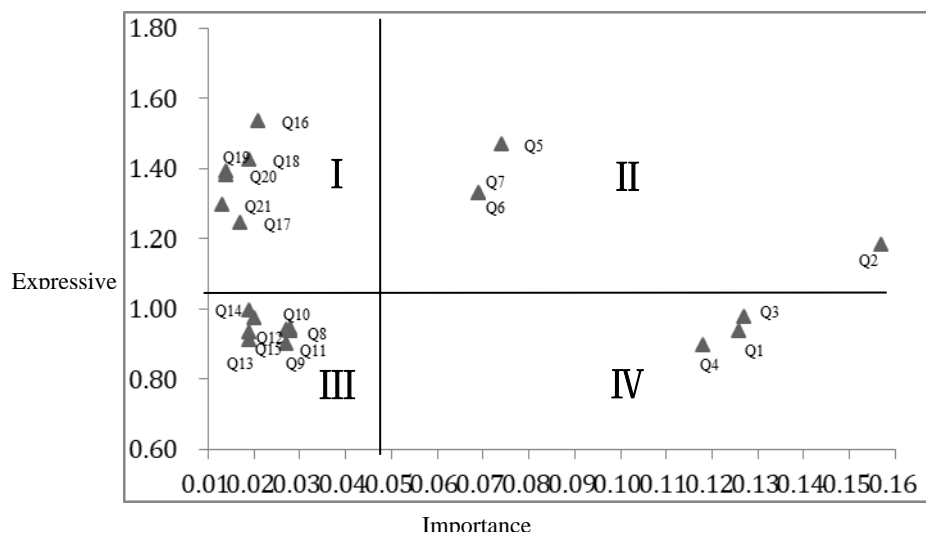

Figure 6: IPA analysis of service quality detailed indicators.

In the above research, the indicators are evenly distributed and concentrated in a specific area. From the figure, it can be observed that the Q16, Q17, Q18, Q19, Q20, and Q21 items are in the first quadrant, which proves that the platform has high performance in these aspects but low customer attention. Q2, Q5, Q6, and Q7 items are located in the second quadrant. Customers think this aspect is very important and the platform performs well. Q8, Q9, Q10, Q11, Q12, Q13, Q14, Q15 are in the third quadrant. Customers think these aspects are not very important, and the platform performance is relatively low. The Q1, Q3 and Q4 items are located in the fourth quadrant, indicating that customers value this feature, but the platform performs poorly.

CONCLUSIONS AND PROSPECTS

With the rapid development of online education, competition among online education platforms has become increasingly fierce. Accurately grasping the needs of each type of consumer and formulating precise service marketing strategies are the key to the success of online education platforms. Consumer value segmentation is the primary prerequisite for service marketing. The research on consumer value segmentation and service quality helps the platform to better classify consumer needs and provide consumers with high-quality platform services. For online education Platform development is of great significance. This article uses the RFM model, combined with the improved SERVQUAL evaluation model to obtain consumer information to classify online education platform consumers, and discusses the classification of two types of customers using fuzzy evaluation and IPA analysis. However, this research still has the following shortcomings, and there are also many shortcomings in the process of this research. This article summarizes it, hoping to provide the research foundation and improve it for later researchers. RFM does not consider weight. Because this research is based on the RFM model for customer value classification, the

customers are divided into 8 sub-categories, and further summarized into two major categories, and provide certain management strategies for different categories of customers, to provide customers Management has reference value. But for different products, the importance of RFM is not equal, so the weight of RFM should be considered, and then it will be more effective to divide customer groups. After categorizing customers, combining basic information such as customer region, customer age, customer class, and customer preference information, we can formulate targeted (regional, phased, and social) marketing plans for different consumer groups to improve corporate marketing activities.

ACKNOWLEDGMENT

This work is partially supported by grant 18AGL024 of the national Social Science Foundation's key project "Value Management Research of Cultural Creativity", China.

REFERENCES

- [1] Alcura, G.A., Gundogar, S.S.K., Tanriverdi, C., Golbasi Simsek, G. & Gursoy, M. (2020). Impact score technique and SERVQUAL comparison for public transportation service quality. *Sigma: Journal of Engineering and Natural Sciences*, 38(2), 715-726. <https://eds.yildiz.edu.tr/AjaxTool/GetArticleByPublishedArticleId?PublishedArticleId=5107>
- [2] Altuntas, S., Derehi, T., & Kaya, İ. (2020). Monitoring patient dissatisfaction: a methodology based on SERVQUAL scale and statistical process control charts. *Total Quality Management & Business Excellence*, 31(9-10), 978-1008.
- [3] Chen, S. Y., Huang, P. R., Shih, Y. C., & Chang, L. P. (2016). Investigation of multiple human factors in personalized learning. *Interactive Learning Environments*, 24(1), 119-141.
- [4] Demir, P., Gul, M., & Guneri, A. F. (2020). Evaluating occupational health and safety service quality by SERVQUAL: A field survey study. *Total Quality Management & Business Excellence*, 31(5-6), 524-541.
- [5] Hu, Y. H., & Yeh, T. W. (2014). Discovering valuable frequent patterns based on RFM analysis without customer identification information. *Knowledge-Based Systems*, 61(1), 76-88.
- [6] Khalili-Damghani, K., Abdi, F., & Abolmakarem, S. (2019). Solving customer insurance coverage recommendation problem using a two-stage clustering-classification model. *International Journal of Management Science and Engineering Management*, 14(1), 9-19.
- [7] Lee, J. W. (2010). Online support service quality, online learning acceptance, and student satisfaction. *The Internet and Higher Education*, 13(4), 277-283.
- [8] Marcus, C. (1998). A practical yet meaningful approach to customer segmentation. *Journal of Consumer Marketing*, 15(5), 494-504.
- [9] Piao, M., & Ryu, K. H. (2017). Local characterization-based load shape factor definition for electricity customer classification. *IEEJ Transactions on Electrical and Electronic Engineering*, 12, S110-S116.
- [10] Wei, H. C., & Chou, C. (2020). Online learning performance and satisfaction: Do perceptions and readiness matter? *Distance Education*, 41(1), 48-69.
- [11] Weili, Z. (2019). Research on hotel customer relationship management system based on the classification algorithm. *International Journal of Information Systems and Supply Chain Management (IJISSCM)*, 12(2), 68-75.
- [12] Zabkowski, T. S. (2016). RFM approach for telecom insolvency modeling. *Kybernetes*, 45(5): 815-827.
- [13] Zhang, Y., Bradlow, E. T., & Small, D. S. (2015). Predicting customer value using clumpiness: From RFM to RFMC. *Marketing Science*, 34(2), 195-208.
- [14] Zhang, Z., & Dai, Y. (2019). Combination classification method for customer relationship management. *Asia Pacific Journal of Marketing and Logistics*, 32(5), 1004-1022.

Research on Design Method of Intelligent Furniture

(Full Paper)

Jie Wang*, Nanjing Institute of Technology, Nanjing, China, 34244119@qq.com

Chang Lu, University of Pécs, Pécs, Hungary, cclu0820@gmail.com

ABSTRACT

At present, the development of intelligent furniture has started, and intelligent technology has been initially combined with furniture products, therefore, some convenient and interesting intelligent furniture products have appeared on the market. Intelligent furniture provides more possibilities for modern life, and offers good interactive experience to users. The emergence of intelligent furniture can be called a major reform in the history of furniture since it has not only realized the diversification of furniture and provided higher scientific and technological content regarding furniture, but also injected fresh blood into people's home and living environment as well as made great changes in people's lifestyle. However, since it is still in its infancy, and there is a lack of systematic theoretical research and guidance, design ideas and technical content, therefore, through the analysis of the concept, composition, development issues and design principles of intelligent furniture, this paper puts forward and take effective measures to guide the design practice, which is conducive to the further development and design of intelligent furniture.

Keywords: Intelligent furniture, intelligence, design method, principle.

*Corresponding author

INTRODUCTION

With the development of network technology, Internet of Things technology and artificial intelligence technology, intelligence has become the mainstream trend of today's social development. "Smart home" has begun to enter the public eye through various media, household industry has begun to pay much attention to the application of intelligent control technology. Furniture, as a part of our home, is one of the daily necessities closely related to people's life, work, study, entertainment and other activities. The traditional production mode and function can no longer meet the needs of the intelligent age, so furniture design and manufacturing will gradually develop towards intelligence along with the advancement of society, which is an inevitable requirement for its development—the term "intelligent furniture" came into being.

In the environment of continuous development regarding science and technology abroad, intelligent furniture emerges endlessly. Designers give full play to their imagination and creativity, making furniture types diverse and styles different. The research of smart home in foreign academic fields focuses on human-computer interactions, and the corresponding product function settings are based on the analysis of user behavior. For example, in 2015, the intelligent desk "Autonomous Desk" (Figure 1), which can adjust the height, will remind users when the user's standing or sitting time exceeds a reasonable range of health. In addition, Autonomous Desk also has the ability to learn and communicate, and users can interact with Autonomous Desk through voice. In 2016, Italian designer Edoardo Carlino designed the Hi-CAN smart bed (Figure 2), which is equipped with a computer, TV and game system, turning the bed into a powerful entertainment system. In 2016, Vitra released a revolutionary intelligent adjustable sofa Lift Bit (Figure 3). It is a number of modular lifting hexagonal seat, which can be used alone or combined into various shapes, and the number depends on the user's needs. At the same time, it is equipped with a mobile APP, which can change the height and number of each seat through mobile phone operations, and switch between chairs, sofas and beds at will. In the field of smart furniture, there are a lot of excellent designs and practices abroad.

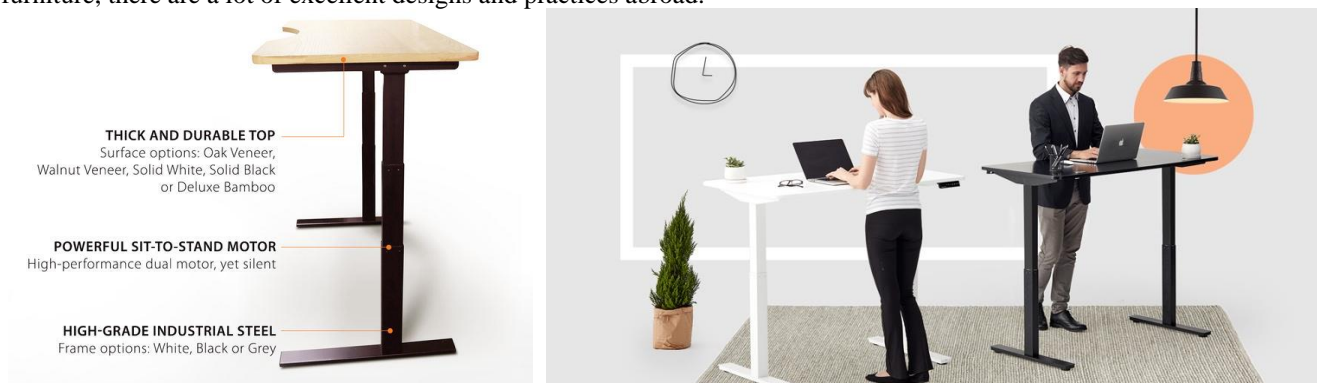

Source: <https://www.autonomous.ai>.

Figure 1: Autonomous Desk



Source: Baidu Pictures.
Figure 2: Hi-CAN



Source: Baidu Pictures.
Figure 3: Lift Bit

Due to the traditional production mode and functional characteristics, intelligent furniture has not established brand awareness in the domestic market. There are few companies specializing in intelligent furniture, some traditional furniture companies have launched intelligent furniture products, but the brand influence is low and technological innovation is not enough. The research on intelligent furniture in the Chinese academic field started late, far behind foreign countries. It was not until the beginning of 2000 that China began to study smart furniture. In 2005, Hongliang Wang, Jixiang Zhong, Jiaqing Tang and others explored the market of intelligent furniture, and tried to classify its types, but they have not yet conducted in-depth research. In 2006, HaiYan Duan's doctoral thesis "Research on intelligent furniture" established the theoretical framework of intelligent furniture, clarified the concept of intelligent furniture, summarized the characteristics of intelligent furniture, and summarized the design principles and steps of intelligent furniture. Afterwards, some experts and scholars put forward the application of intelligent control theory and technical methods regarding the specific furniture design to guide the design of intelligent children's furniture, intelligent hospital bed, intelligent kitchen furniture and intelligent office furniture, etc. Until now, the research direction of intelligent furniture has gradually become multidimensional, which has a reference function for the progress of intelligent products of today.

THE DEVELOPMENT STATUS OF INTELLIGENT FURNITURE IN CHINA

In the context of intelligent industry, the development of intelligent furniture has begun to take shape. Various types of intelligent furniture emerge endlessly as having intelligent furniture has become a trend. It is not only the creative design of designers or furniture companies, but also the inevitable product of temporal advancement, social progress, economic development and technological innovation.

However, because it is an emerging industry, its development still lacks experience, and some fields are new and untouched technologies. Therefore, the development of intelligent furniture industry also has the following problems: 1) The design lacks innovation, some products simply add intelligent means such as a screen, audio-visual equipment, sterilization and disinfection facilities, as well as a temperature control system to the main body of the furniture. The combination is too rigid and fails to have a good integration. The use of new technology is only for the purpose of achieving intelligence, but not really convenient for people's lives. 2) The designed products are often complicated to operate, so users with good receptive ability may accept the used method relatively quickly, but users with poor receptive ability will experience a long period of learning to master. 3) Many of the intelligent furniture products are still in the conceptualization or experience stage, so it is difficult to mass-produce and put them on

the market. 4) The hardware and software required for intelligent furniture are expensive to design and manufacture, such as voice recognition, sensors and other special intelligent components, which have strict requirements considering technology, quality and safety, thus resulting in high prices of intelligent furniture products. 5) Although there are many types of intelligent furniture products, all kinds of products in the whole intelligent furniture industry are still relatively isolated, and not well integrated into a complete and interconnected system. 6) The degree of intelligent furniture is low and the progress is slow, the transformation from traditional furniture to intelligent furniture is relatively difficult, and there is a large industry span in research, development and design. It is necessary to combine the intelligent sensing system, electronic equipment and other high-tech facilities with the design, materials and craftsmanship of traditional furniture.

CONCEPT

Intelligent furniture is still in the early stages of research and experimental development. These smart appliances are based on modern furniture, comprehensively using multi-disciplinary and multi-field technical achievements, adopting modern digital information processing and communication technology. They collect various types of signals in real time, which are recorded, judged and fed back by the controller according to the predetermined program, and automatically reflect the needs of users. In a broad sense, intelligent furniture are devices that integrate high-tech into the development process of furniture design through system integration, realizing the optimization and reconstruction of furniture type, material, structure, process or function, endowing furniture with some functions that used to be completed by human beings. In a narrow sense, intelligent furniture apply the technical principles of mechanical transmission, sensor, single-chip microcomputer and embedded system to the furniture entity, turns ordinary furniture into smart items, and forms the interactive relationship between people and furniture. Compared with traditional furniture, smart furniture embodied more humanized features, with self-adaptive, self-sensing, intelligent, fashionable and multi-functional characteristics, making the home environment and life experience more convenient and comfortable. The intelligent design of furniture is the trend of future life.

COMPOSITION

Intelligent furniture is an integrated control system, which is mainly composed of two parts: hardware facilities with intelligent functions and software facilities with an intelligent programming system. Hardware is the executive part of realizing intelligent functions, the transmission and realization device of intelligent effects, including an actuator, sensor system, brake system, and furniture body, etc., and the integration of mechanical transmission and realization devices for various automatic control of furniture.

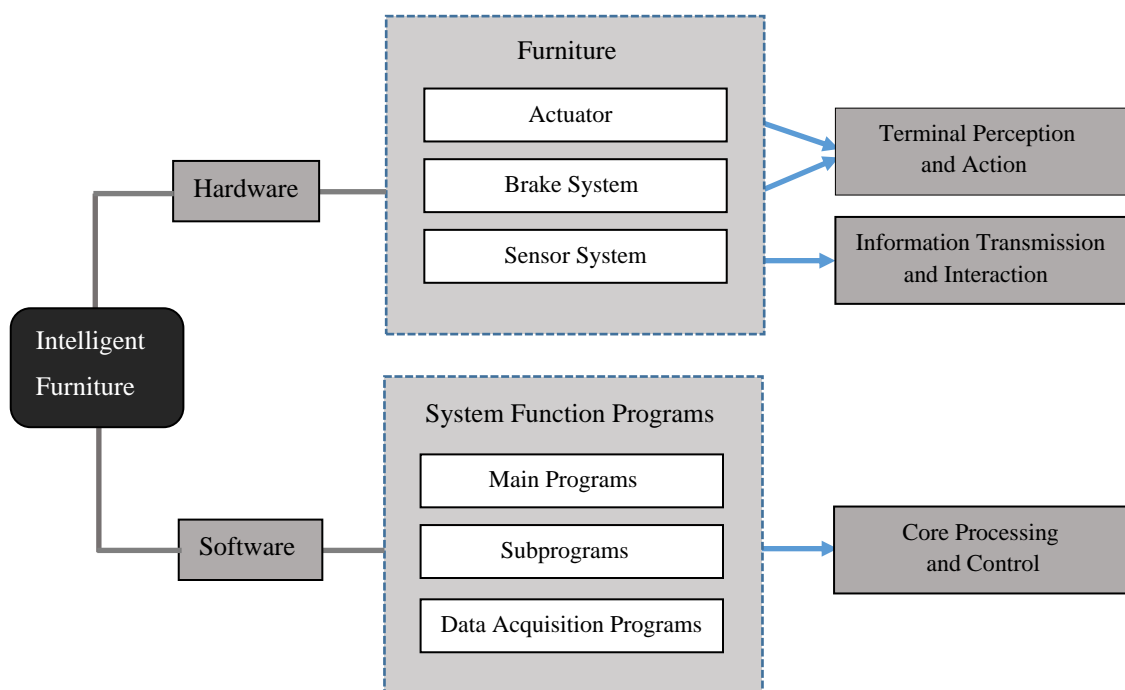

Source: This study.

Figure 4: Composition of intelligent furniture (Drawn by author)

Software is the "soul" of intelligent furniture control, and with its basic content, it often includes system function programs such as main programs, subprograms, and data acquisition programs, as well as various module control programs, and subsidiary program for system detection, man-machine interface and peripheral equipment management. Hardware equipment is to embed the intelligent system into the original furniture, with executive functions; the software system can control the perception of hardware

devices embedded in the intelligent furniture body. The hardware device converts the received control information into an electrical signal and then sends it to the software for processing, the processing result is transmitted to the hardware to execute the command in the form of an electrical signal. Through the cooperation between software and hardware, a complete process from the command issuance to the final response is realized.

From the perspective of high-tech products, all the hardware and software components of the intelligent furniture can be broken up and reconstructed into three levels: terminal perception and action, core processing and control, as well as information transmission and interaction (Figure 4). Among them, the terminal perception and action refers to various discrete perception terminals and command action terminal nodes of furniture. In addition to maintaining the functional attributes of traditional furniture, it also needs to provide a variety of rich human-computer interaction interfaces, such as electronic operation panels, high-precision touch screen, etc.. The core processing and control as well as information transmission are basically the same as the software concept, as they are the core mechanism for various data processing. They are often placed inside the furniture as a core module, and connected to other terminal modules through the control bus to convey various "commands".

CLASSIFICATION

Mechanical Intelligence

Mechanical intelligence is that the mechatronics device composed of various parts is implanted into the furniture body, and the mechanical device or transmission mechanism is operated in a certain way through manual control. The transmission system converts the electric signal sent by the controller into action commands, and the motor provides kinetic energy through the friction or linkage between gears, levers, transmission shafts and other basic parts to drive the entire system to stretch, fold, flip, rotate, and move the furniture, components or assembly accessories to achieve the transformation or combination of furniture units and functions. Through a simple touch, light press and other actions, the user can initiate the automatic opening or closing of the furniture cabinet or drawer and automatic lifting, rotation, expansion and other functions of the desktop. In this way, it breaks through the limitations of traditional furniture in size, style and function, completes the upgrade and transformation of traditional furniture, realizes mechanical intelligence, and meets the needs of users for multiple specific functions.

Electronic Intelligence

Electronic intelligence is the combination of advanced and cutting-edge electronic technology products and traditional furniture through wired or wireless electronic remote control or touch control to realize the intelligent functions of furniture. The user only needs a simple touch action to control the automatic operation of the furniture through an induction device, and realize the adjustment of various functional parameters. Such as playing audio and video, turning LED lights on and off or adjusting the brightness of the light. Figure 5 is the OSIM smart massage seat. Through the control of the remote control or buttons, you can adjust the massage mode, massage position, massage strength, and adjust the seat size and angle according to the different body shape of the user, as shown in Figure 6. There are functions of heating and playing music, which is entertaining in the process of relaxation.



Source: <https://www.osim.com.cn>.

Figure 5: Smart Massage Chair



Source: <https://www.osim.com.cn>.

Figure 6: Functions of Smart Massage Chair

IOT Intelligence

IOT (Internet of Things) intelligence is to implant advanced intelligent systems or intelligent components (sensors, embedded systems, etc.) into the furniture body and connect intelligent hardware, APP software and data platforms through the network, with the network center and data center as the core. In addition, it also makes use of mobile intelligent terminal devices (mobile phone, tablet computer, etc.) and wireless network technology to realize data processing and the control of furniture. The application of Internet of Things technology can integrate the intelligent furniture control system into the intelligent home control system. Intelligent furniture can be regarded as a subsystem of the Internet of Things and developed into a kind of terminal, which can realize the deep interaction between humans and furniture and finally realize the intelligent operation of family life.

Sensors

As a detection device, the sensor is usually composed of sensitive components, conversion components, signal conditioning and conversion circuit. These components can sense the information transmitted from the outside and convert it into a certain regular and specified form of electrical signals and other forms of output, in order to realize the transmission, processing, storage, memory, display, recording and control of information, and that is the primary link to realize intelligence. Sensors can identify the external environment information independently, so that objects can have the perceptive ability of vision, hearing and touch like human beings. Sensors are implanted into the furniture body, such as photosensitive sensors, sound sensors, temperature sensors, etc. in intelligent furniture. It detects or perceives the user's actions, touch and other information, so that the furniture has specific intelligent functions of automatic detection, automatic sensing and automatic control. Due to the application of sensor technology, furniture is transformed into multi-functional products, which is a great leap in the field of furniture. The smart wardrobe with smart fitting mirror is shown in Figure 7.



Source: Baidu Pictures.

Figure 7: Smart Wardrobe

Embedded systems

The microcomputer processing system is embedded in the furniture body. The embedded system is equivalent to the "central nervous system" of intelligent furniture, which is integrated by software and hardware, and mainly composed of an embedded processor, operating system, electromechanical devices and other supporting hardware and application software. The embedded processor is the core, and its performance determines the operating effect of the entire intelligent system. At present, embedded systems have been widely used in smart phones, digital cameras, household appliances as well as vehicle navigation systems, and its development also gave birth to the emergence of intelligent furniture. Embedded systems have been widely used in the field of furniture, and regarding its functionality, users can use mobile phones, tablet computers and other mobile terminals to control the specific functions of furniture through wireless network or remote control. Smart kitchen (Figure 8) can back up the data of

refrigerators, electric rice cookers, ovens, dish washers, microwave ovens and other devices to the data center, obtain the data from the data center with mobile phones, and set tasks for multiple devices, so that the liberation of kitchen labor can be easily realized.



Source: Baidu Pictures.
Figure 8: Smart Kitchen

The "2025 Concept Kitchen" project launched by IKEA was in collaboration with the design company IDEO and students of Lund University and Eindhoven University of Technology. IKEA assumes that the kitchen in the future will integrate more application scenarios, and a single tool may connect more functions. IKEA has designed an integral part of the kitchen 'A Table for Living'. The dining IKEA table plays an important role in our daily lives where individuals come together to share not only food but also experiences. As such the table will not only be used to dine, but will also serve as the hob, the preparation table, and not only this; it will also act as a table for work and play. "A Table for Living" (Figure 9, 10) is a smart home that combines technology and creativity, and it is called a kitchen control center rather than table, it looks simple and plain, with IKEA's consistent style. The table recognizes the grocery items kept on it, through a camera located above, and suggests recipes involving these ingredients. The idea is to waste less and engage with the food in order to be more mindful and live sustainably. With the table, you no longer have to worry about cooking, for example, putting potatoes and tomatoes together, you will know how to turn them into delicious dishes, you can also import a recipe and the table will guide you step by step. Magnetic coils below the surface enable the table to be used as an induction top for different dishes to be prepared simultaneously. It is very convenient to make a cup of coffee and charge the phone, while heating the food, it can also be used for children to play, and they do not have to worry about being burnt. In short, the aspect that makes this table efficient is its quality of unobtrusiveness since different features have been integrated without any visual heaviness, enabling it to be used in a flexible manner.

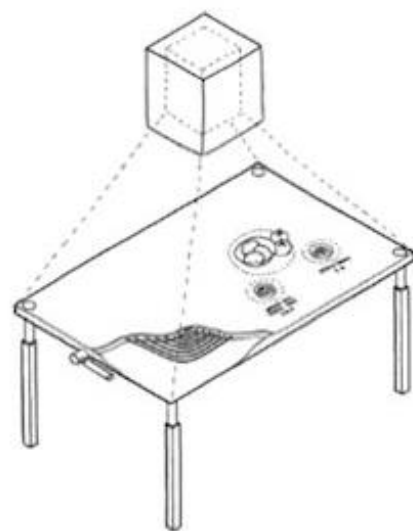

Source: Baidu Pictures.
Figure 9: A Table for Living- IKEA Table



Source: Baidu Pictures.
Figure 10: Functions of the Table

DESIGN METHODS AND PRINCIPLES

Compared with traditional furniture, the design of intelligent furniture is an innovation in itself. In addition to following the principles of traditional furniture design, it is also necessary to introduce intelligent technology in a clever and reasonable way, by means of using modern science and technology to endow it with new functional characteristics, or improve its material and structure. Besides, it is important to transplant or learn from the design of other fields to realize its own innovation, so that traditional furniture and intelligent technology can be perfectly integrated, as well as it is desired to avoid to have one-sided pursuit of innovation and too rigid combination. It is necessary to design furniture products that truly meet the needs of users, conform to modern aesthetics, facilitate daily use, and improve people's quality of life. Therefore, the design of intelligent furniture should meet the following principles.

Safety Principle

Safety is the first consideration in intelligent furniture design since it is directly related to the safety of users and home. The security here includes not only the physical security of people using furniture products, but also the privacy security of users. Therefore, security is particularly important.

As for the physical safety of intelligent furniture, since the intelligent effect needs the support of electronic and mechanical components, intelligent furniture is more prone to electrical and mechanical safety problems. It includes two aspects: first, there cannot be any potential safety hazard in the furniture during design, and the location of the circuit and the electronic mechanical device has to be reserved in advance. In order to reduce the risk of an electric shock, intelligent furniture should adopt a voltage safe for humans as much as possible, install leakage protection devices, and overload protection measures, as well as try to use materials with good insulation properties. Second, the application process of furniture has to be safe, electronic chips and machinery will emit heat during work, so a heat dissipation system must be installed to prevent high temperature caused by burning components and leakage. For example, some automatic trigger devices, such as the upturned door and drawer of intelligent kitchen systems provide electric energy for itself through batteries instead of the traditional circuit.

About the privacy security of intelligent furniture. The development of the internet and cloud services has made people's lives surrounded by huge amounts of data, although the concentration of data is convenient for query, it also increases the risk of information leakage. The design of intelligent furniture also needs to strengthen the management in terms of data security protection, adopt the technical means of identity authentication, biometric recognition (fingerprint recognition, iris recognition, facial recognition, etc.), access control and data encryption to improve the system security and prevent the leakage of user's information and data.

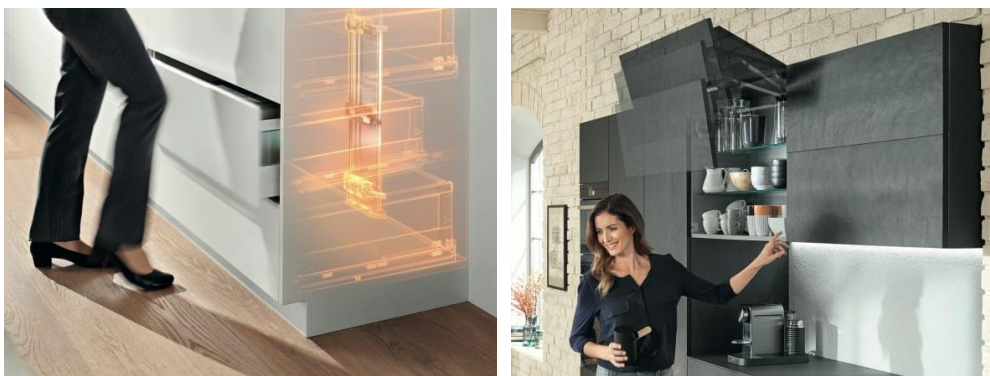

Source: <https://www.blum.com/cn/zh/>
 Figure 11: Automatic Uprturned Door and Drawer

Easy Operation Principle

The design purpose of intelligent furniture is to meet the needs of people's daily life and work. In the design, the target consumers and their acceptance range should be fully considered. The easy-to-understand operation interface and the concise way of use can make people clear at a glance, enable users to have a good user experience, and establish a "harmonious dialogue" that facilitates communication between users and products. Although most of the intelligent means are high-precision technology, in the design, interaction design, interface design and ergonomics should be used to transform complex intelligent systems into intuitive and easy-to-use methods. Intelligent furniture liberates human hands to a certain extent, and realizes the operation of intelligent furniture through buttons, smart phones and touch screens, etc., which brings convenience to people's lives and makes users feel that "smart" is integrated into "life" .

Humanity Principle

While intelligent furniture is based on the characteristics of practicality, more humanistic concepts should be incorporated into the design, combined with the principles of ergonomics, emerging technologies, and the use of green materials. At the same time, from a psychological point of view, the design of intelligent furniture also needs to meet the psychological and aesthetic needs of users, adhere to the humanized design principles, reflect all the "human" relationship closely related to the product life process, and achieve the best coordination and unity with users with the help of high technology.

For example, in the design of intelligent seats, our common seats are designed according to the human standard scale or typical scale. This scale is generally based on the average value of a certain stage, although this is an emphasis on the principle of humanity, but we can further improve and upgrade the humanized design in combination with new technologies and new methods, and apply ergonomics to the design of intelligent seats in a more flexible and targeted manner. It is necessary to fully consider the needs of different ages, the needs of different users, the needs of different usage scenarios and the needs of different usage methods as well as other situations. The scientific and reasonable "adjustable" size is adopted in the design of intelligent seat, so that users can make multi-directional and multi-angle adjustments of the back, armrest, and sitting surface according to their body size, environment and state at any time to feel comfortable and relaxed, as it is shown in Figure 12. Intelligent furniture will serve people's feelings, safety and health more humanely.



Source: Baidu Pictures.
 Figure 12: Intelligent Adjustable Seat

Aesthetic Principle

Because of its special intelligent expression, intelligent furniture should pay attention to the matching degree between the intelligent system and the furniture body. In the design, the addition of intelligent components should be considered in advance, and the electronic components should be hidden or integrated into the furniture skillfully. Due to the complexity of the internal organization, the relationship among the components must be carefully considered during the design process to prevent electronic components from affecting the aesthetics of the furniture. At the same time, the addition of modern intelligent technology can further enhance the aesthetics and value of the furniture itself, electronic display technology and mechanical technology can be used to add visual effects such as sound and light to furniture. In addition, intelligent identification technology and interactive technology can be used to give furniture vitality, so as to realize the interactive communication between humans and machine, and enhance the fun of use.

Easy Processing Principle

The ultimate goal of smart furniture design and development is to go to the market, so the production and processing links should be considered in the design. When designing, standardized universal modular units are advisable, which can bring great convenience to the production and processing of intelligent furniture. Uniform molds, parts, and materials can all bring about the optimization and upgrade of the intelligent furniture design, make it easy to process and produce. The use of expensive and complicated parts should be avoided, thereby simplifying the production process to achieve mass production. Combined intelligent technology can also be used in the design process to make each function into a separate module component, so users can combine them according to the modules when purchasing, while satisfying individualization. The types of modules that need to be processed in the manufacturing process are reduced, which facilitates mass production and reduces processing costs. With the advancement of science and technology, intelligent materials come into being and its application can reduce the use of non-renewable resources and optimize the whole process of furniture products to a certain extent.

Functionality Principle

As a new intelligent product, compared with traditional furniture, the most prominent feature of intelligent furniture is more emphasis on function. It mainly includes the inherent functions of furniture and the new functions brought by intelligence. Intellectualization is an upgrade of traditional furniture, which is based on the functional theory of traditional furniture, moreover the extension and expansion of furniture functionality under the promotion of science and technology development and the needs of the times. Furniture is no longer an immutable static object, but a product of artificial intelligence with more possibilities. In the process of design, functionality and intellectualization are master-slave relationship, and intellectualization must be carried out on the basis of obedience to functionality. Different consumers will have different needs, after clarifying their needs, so we can design and improve the functions in a targeted manner. On this basis, intelligent design is carried out, giving it new functions or reducing or even replacing some human activities through intelligent devices, so that it can better integrate with the furniture to meet user needs.

First of all, the original functions of furniture can be deepened. For example, the function of the bed is to provide a good sleep environment, however, the development goal of the smart bed should be to make sleep more comfortable and smarter. Sleep can be divided into bedtime, sleep state and waking up, correspondingly smart bed should have the functions of helping sleep, reminding people to sleep, improving sleep quality and waking up. Secondly, it can expand new functions and combine the functions of intelligent devices with traditional furniture to meet people's needs in an all-round way. For example, the bedside table can be equipped with wireless charging and music playing equipment, and tea table can have the functions of refrigerator and intelligence. Finally, under the new requirements, according to the existing products and the relatively mature technological achievements, carry out, imitate, transplant or modify, and innovatively design products with different functions and types, it is possible to provide new design ideas for intelligent furniture. For example, the dehumidification and sterilization function of intelligent wardrobe imitates the indoor dehumidifier.



Source: Baidu Pictures.

Figure 13: Intelligent Bedside Table and Tea Table

CONCLUSION

Intelligent furniture is the trend and direction of functional product development in the future furniture industry, is an exploration attempt of the furniture industry in the field of information technology, and it is the collision between the traditional industry and the emerging industry. The design and manufacture of intelligent furniture requires the interdisciplinary and comprehensive application of multi-disciplinary and multi-field technical achievements. It is based on the modern fashion furniture, combining traditional furniture design and production with modern digital information processing together with other technologies, as well as using modern technology to enhance the aesthetic and value of traditional furniture. It enables intelligence to enter people's, which will make the intelligent functions brought by technology visible and tangible.

With the rapid development of economy, it is an inevitable trend for furniture to realize intelligent functions, and as the development of intelligent technology and intelligent materials, intelligent furniture will become more "intelligent" in the future, it will be more convenient to operate, and there will be smoother human-computer interactions, as well as it will be more convenient for actual use, which will gradually transform furniture from static and inanimate to dynamic, interactive and even intelligent control. While satisfying the basic functions, intelligent furniture is more in line with the needs of modern users, expand the scope of the consumers, integrate science and technology with furniture, give users a fresh feeling and a better user experience brought by the new intelligent technology that truly meets all the needs of people for furniture.

ACKNOWLEDGMENT

This work is partially supported by grant YKJ201990 of Talent Introduction Scientific Research Start-up Fund of Nanjing Institute of Technology, China. And it is also partially supported by 2020SJA0450 of Philosophy and Social Science Research in Colleges and Universities of Jiangsu Province, China. And it is also partially supported by CACD202013 of Cultural, Artistic and Creative Design and Research Institute Fund of Nanjing Institute of Technology, China.

REFERENCES

- [1] Cooper, A., Reimann, R. & Cronin, D. (2007). *About Face 3: The Essentials of Interaction Design*. Indianapolis, Indiana: Wiley Publishing, Inc.
- [2] Albino, V., Berardi, U., & Dangelico, R. M. (2015). Smart cities: Definitions, dimensions, performance, and initiatives. *Journal of Urban Technology*, 22(1), 3-21.
- [3] Chen, D. W., Wu, Y. C., Li, W. J., & Yan, W. J. (2014). Design and implementation of smart home system based on ARM. *Information Technology*, 5, 67-70. Retrieved from https://xueshu.baidu.com/usercenter/paper/show?paperid=861a81a200c69c096e34d3fced7dd243&site=xueshu_se
- [4] Gómez-Carmona, O., Casado-Mansilla, D., & López-de-Ipiña, D. (2018). Multifunctional interactive furniture for smart cities. In *Multidisciplinary Digital Publishing Institute Proceedings* (Vol. 2, No. 19, p. 1212). <https://www.mdpi.com/2504-3900/2/19/1212>
- [5] Guo, Y., Yi, X. Q., & Chen, H. (2016). Research on intelligent furniture and its design method. *Furniture*, 37(1), 70-73. Retrieved from https://xueshu.baidu.com/usercenter/paper/show?paperid=aff83ffb399ada46c12ffceba491220e&site=xueshu_se
- [6] Kim, S. (2015). A study for building smart home environment based on modular equipment design concept. *Art and Design Review*, 3(2), 42-48.
- [7] Lehofer, M., Heiss, M., Rogenhofer, S., Weng, C. W., Sturm, M., Rusitschka, S., & Dippl, S. (2016, April). Platforms for Smart Cities—connecting humans, infrastructure and industrial IT. In *2016 1st International Workshop on Science of Smart City Operations and Platforms Engineering (SCOPE) in Partnership with Global City Teams Challenge (GCTC)(SCOPE-GCTC)* (pp. 1-6). IEEE.
- [8] Li, K. X., & Yang, Z. Q. (2019). Composition system and design principle of intelligent furniture. *Furniture*, 40(5), 45-49, 60. Retrieved from <https://xueshu.baidu.com/usercenter/paper/show?paperid=1q4900w04s7h0g60852m0cm0cv390078>
- [9] Liu, Y. & Yu, S. L. (2019). Research and design of Bluetooth smart office chair based on app. *Furniture*, 40(5), 79-81. Retrieved from https://xueshu.baidu.com/usercenter/paper/show?paperid=1j7x0860us000pp02u060my0v7345731&site=xueshu_se
- [10] Mugge, R., Schoormans, J. P., & Schifferstein, H. N. (2009). Emotional bonding with personalised products. *Journal of Engineering Design*, 20(5), 467-476.
- [11] Nabian, N., Offenhuber, D., Vanky, A., & Ratti, C. (2013). Data dimension: accessing urban data and making it accessible. *Proceedings of the Institution of Civil Engineers-Urban Design and Planning*, 166(1), 60-75.
- [12] Tang, K. J. & Peng, X. (2015). The analysis of furniture intelligent system. *Furniture and Interior Design*, 4, 11-13. Retrieved from https://xueshu.baidu.com/usercenter/paper/show?paperid=339ae31330c9de4676bab526ea39b754&site=xueshu_se

- [13] Wei, Z.C., Han, J.H., Zhang, J.J. & Zhang, L. (2005). Design of the remote control system in smart home. *Journal of He Fei University of Technology* (Natural Science), 28(7), 751-754. Retrieved from https://xueshu.baidu.com/usercenter/paper/show?paperid=183u0vg0ru1u06e0366s0c40rg724013&site=xueshu_se
- [14] Wu, Z.H. (2016). Manufacturing mode of furniture industry in industry 4.0. *China Forest Products Industry*, 43(3), 6-10. Retrieved from: https://xueshu.baidu.com/usercenter/paper/show?paperid=f9f541cf89a9c1d2438dbf38b4932e41&site=xueshu_se
- [15] Xue, Y.H. & Kang, L.J. (2019). Research on intelligent design of furniture. *Industrial Design*, 1,142-143. Retrieved from: https://xueshu.baidu.com/usercenter/paper/show?paperid=1d330c20v9400ee0mr0m0tv0j5311584&site=xueshu_se
- [16] Zhang, Z. (2013). Analysis of the development of smart home. *Technology Platform*, 159 (11), 77-80. https://xueshu.baidu.com/usercenter/paper/show?paperid=12490e30e3520860dm5g0ce0pj436049&site=xueshu_se
- [17] Zheng, W., Li, Z.M., Luo, D. (2013). Design and implementation of wireless network in smart home. *Video Engineering*, 37(21), 56-59. Retrieved from: https://xueshu.baidu.com/usercenter/paper/show?paperid=360754077bbcaa4cfc82d5541defdd8&site=xueshu_se

Research on Design of Intelligent Cleaning Robot for Solar Panel

(Full Paper)

Shengzan Yan*, Institute of Art and Design, Nanjing Institute of Technology, Nanjing, China,
j00000002993@njit.edu.cn

Ye Jian, Institute of Art and Design, Nanjing Institute of Technology, Nanjing, China,
hebeiyzs@163.com

Lijun Xu, Institute of Art and Design, Nanjing Institute of Technology, Nanjing, China,
158823277@qq.com

ABSTRACT

Solar power generation has become one of the main sources of power resources, but solar power stations are mostly built in desert areas with large wind and sand, and solar panel arrays need to be cleaned frequently to ensure power generation efficiency. In order to effectively improve the cleaning efficiency of solar panels, reduce the labor intensity, and better meet the requirements of photovoltaic power station for power generation efficiency, based on an existing solar panel cleaning robot, an improved design method is adopted to solve the charging problems, wind overturning problems and transportation difficulties. The innovative design on structure and shape of solar panel cleaning robot products is done, and the 3D model is established by using 3D modeling software. The design ideas and structural principles of several different design schemes are described in detail, which provides reference for the upgrading of solar panel cleaning robot. The role of big data and artificial intelligence in design is analyzed, and that will bring new development direction of intelligent cleaning robot for solar panel. Finally, the work is summarized and the research prospect is put forward.

Keywords: solar power panel, intelligent cleaning robot, wind resistant design, convenient transportation design, structure and shape design.

*Corresponding author

INTRODUCTION

Solar Power Generation

Solar energy is a renewable, clean and reliable energy source. In recent years, the national and local governments have strongly supported photovoltaic power generation, and the installed capacity of photovoltaic power generation in China is increasing by a large margin every year (Zhang *et al.* 2017). Solar panel is an important power generation device for photovoltaic power generation. In order to ensure power generation efficiency and absorb as much sunlight as possible, it is particularly important to clean the solar panel (Bernard, 2018). At present, the technology of solar panel cleaning equipment is not mature, the price is expensive, and the cleaning efficiency is not high. There are still various problems in the specific use of the formed products. In view of this situation, the structure and shape of the solar panel cleaning robot are innovatively designed, which is mainly used to solve the practical problems in the use of products.

Solar panels typically consist of photovoltaic (PV) cells covered by a protective glass coating, which generate electricity when subjected to radiations. However, the capability of electricity generation is constrained due to layer of dust on PV modules. The solar panels in the Middle East and North Africa are easy to be polluted by sand dust. Photovoltaic power stations in China are mostly built in desert areas as shown in Figure 1, which is windy and dusty, so solar panels need to be cleaned frequently. In some areas, if not cleaned up for one month, the power generation will be reduced by about 10% (Zhang *et al.* 2019; Fan *et al.* 2018). Hassan *et al.* (2017) designed a robotic cleaner for cleaning PV modules of Quaid-e-Azam Solar Park (QASP). The mechanism primarily consists of ducted fan, roller brush and blower fan. Also Said *et al.* (2018) presented an innovative low-cost cleaning technique for photovoltaic panels. From this it can be seen the importance of solar panel cleaning to guarantee the efficiency of the electricity generation.

Status of cleaning robots

Riawan *et al.* (2018) said Industrialization in our modern society is reflected by the transformation from traditional life style into modern one. The transformation can be seen from development of technology that occurs rapidly. Today, the use of robots reaches all aspects of human life, both in the industry and in everyday activities. Robots have assisted people in everyday activities and its application helps human activity to reduce level of accident. Type of works that are suitable for robots are tedious, dangerous, and boring jobs such as the cleaning of solar panel.

In recent years, solar panel cleaning robot has gradually developed and replaced manual cleaning. The appearance and working principle of the robot are various, but they can be mainly divided into two types: small-scale trackless walking type and big crossing track walking type, as shown in Figure 2. The three types of robots on the left side of the figure are suitable for cleaning solar panels which are arranged approximately in a straight line, and need to have a specifically set walking track or

be displayed by the composed solar panel supports; the three cleaning robots on the right side of the figure are similar to the common household sweeping robots, which are more suitable for occasions where the tilt angle of solar panels is not too large, and can walk freely without relying on the track but arranged by program. It is easy to work on solar panels arranged in sheets.



Source: Taken from North-West of China.
Figure 1: Solar power station.

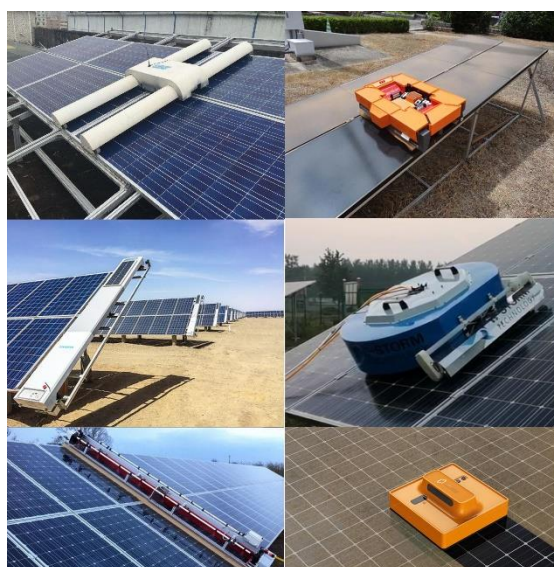

Source: Download from website (<https://image.baidu.com/>).
Figure 2: Two main categories of cleaning robot for solar panel.

Patil *et al.* (2017) reviewed different existing methods of solar panel cleaning, after considering advantages and limitations of each, they got a conclusion that a brush type solar panel cleaning could be ideal as it requires no water or a little water for removal of dust. Also, it is low cost and can be indigenously developed. It also operates and considered as an auxiliary unit of the existing solar PV system. But there are still several points to be improved. Under investigation and analysis, the existing solar panel cleaning robot products are classified and summarized as in Table 1.

Table 1: The status of cleaning robot for solar panel.

No.	Style	Small-scale trackless walking type	Big crossing track walking type
1.		The model is compact and convenient to handle and use, but the battery capacity is limited, so it is not suitable for long time and large area operation	The model is too large, and the transportation is not very convenient. It usually needs split transportation, on-site assembly, and the continuous working time is limited, which needs to be improved
2.		Basically realize the cleaning function, and divided into dry and wet cleaning technology, dry is more suitable for the working environment, will not leave clean water stains	It is mainly used for water-free cleaning operation such as roller brush and row brush, which is suitable for the occasion with linear arrangement, small distance between front and back and small height difference between upper and lower
3.		The electronic control technology is used to plan the walking track, which is easy to cause the problems of insufficient cleaning or repeated cleaning	The walking path is controlled by the track, and the surface of the solar panel can be cleaned completely
4.		It is not suitable for working on the solar panel with large tilt angle, and it is easy to be blown over by	It is suitable for working on the solar panel with any tilt angle, and the problem of preventing being blown

wind	over by wind should also be considered
------	--

Source: This study.

Since most solar panels are inclined, the inclination angle is related to the solar altitude angle, and the theoretical optimal inclination angle is equal to 90 degrees subtract the local solar altitude angle. However, due to the continuous change of solar altitude angle, and the solar panels are mostly fixed angle type, so they are mostly installed at about 40 degrees. Therefore, compared with the small-scale trackless walking cleaning robot, the crossing track walking cleaning robot is more suitable for the working environment, has more stable working performance, better cleaning effect and higher working efficiency. As can be seen from the analysis in Table 1, there is still some problems to be solved even for the crossing track walking type cleaning robot.

STUDY OF DESIGN FOUNDATIONS——ORIGINAL SCHEME

The original scheme has a good cleaning ability, and through the design of the walking mechanism, it can realize automatic adjustment within a certain range, so as to cross certain obstacles. The specific advantages are as follows:

① The setting of two strip brushes and one rolling brush overcomes the shortcomings of ordinary single rolling brush cleaning robot, such as soft and long bristles, easy knotted when stained with water and ash, high-speed rotation damages photovoltaic panel, and the bristles are too soft to remove bird droppings and other sticky substances. The middle row brush is used to push away the coarse sand and gravel, so as to prevent the rolling brush from rolling with gravel and damaging the photovoltaic panel. At the same time, the strip brush can also help the dust fall along the edge better to avoid dust residue on the PV panel. As shown in Figure 3.

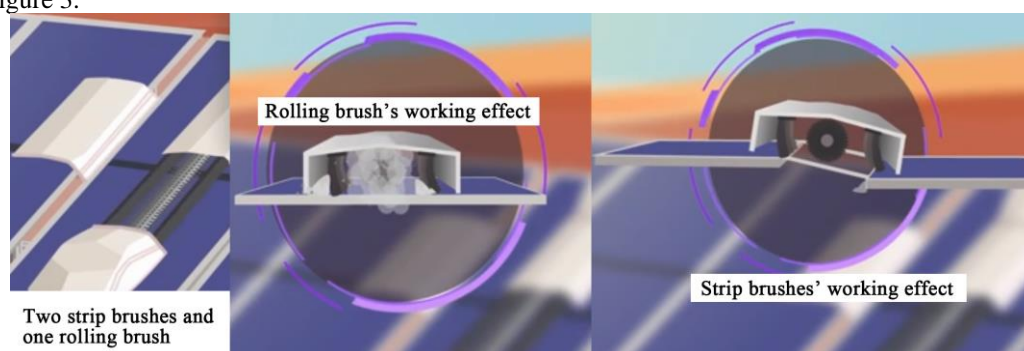

Source: This study.

Figure 3: Cleaning structure of the cleaning robot.

② It can climb a slope with an inclination of 28° and a plane dislocation with an angle of 12° and is automatically adjusted after the tilt is not synchronized. This can avoid the uneven driving power from different wheels caused by bad moving posture, which weakens the ability to cross obstacles and even damage the motor. This ability also allows photovoltaic panels not to be completely aligned, thus expanding the working range of the robot. As shown in Figure 4.

③ The maximum height difference of 5cm can be crossed. When the height difference between adjacent panels exceeds the radius of the wheel, it will return automatically after three trials under the action of sensors and controllers.

④ It is equipped with two sets of brushes, soft brush and hard brush. According to the type of dirt on the photovoltaic panel, the brush can be replaced. The hard brush is used to clean the sticky substances such as bird droppings and insect eggs, and the soft brush is used to clean up fine dust.

In use and transportation, it is found that the original scheme still has several defects which need to be improved, mainly focusing on three aspects: first, the working hours are limited by the battery power; second, it is inconvenient to transport; third, it is to prevent wind overturning.

RESEARCH ON DEFECTS-ORIENTED DESIGN

Design to prevent overturning by wind

The shell of the original scheme is divided into three sections, which are made of plastic material and are made by suction molding process. They are installed above the internal structure of the product, such as walking and cleaning, in a semi enclosed shape. In the process of use, due to the bad working environment of the solar panel cleaning robot, windy weather is often encountered. The strong wind will not only bring certain wind resistance to the robot, but even overturn the whole robot when it is serious. In the face of this problem, thinking of the reason that "Dayu flood control" Dredging and drainage are better than blocking, it is also associated with the problem of wind resistance in the driving of the car. Observing the shape of the car, in addition to the conductivity of the vehicle shape, the front part of the car is also designed with a ventilation area. To solve the windproof problem of the solar panel cleaning robot, we should also take the way of relieving the wind. The design results are shown in a, b, c, d, e, f in Figure 5.

Figure 5a shows the sketch of the design scheme for simulating the shape of the front of the car and streamline modeling of the body with design of vent channels. Figure 5b shows the design based on the same principle by observing the wind deflector at the air outlet of the air conditioner. The upper air outlet is set at the upper part of the shell. The wind resistance pressure sensor

controls the motor to drive the wind deflector to operate. Figure 5c shows the design through thinking of the aircraft wings running under the condition of wind. The two sides of the robot are wind boards. The motion principle of the wind board is slide track type. The body is equipped with weather sensing system, which can control the wind board to slide in different degrees by sensing the weather. Figure 5d shows the hand-painted effect picture of the final scheme, and the side vent is set to relieve the wind that causes the robot to be overturned. Figure 5e shows three views of the final scheme. Figure 5f shows the effect picture after modeling and rendering of the final scheme. The shell is designed and deformed according to the shape of the front of the car. The motor parts at both ends are made into similar convex lamp forms, the fuselage is made into streamline like automobile, the gray parts are vents, and the overall material is PC or ABS.

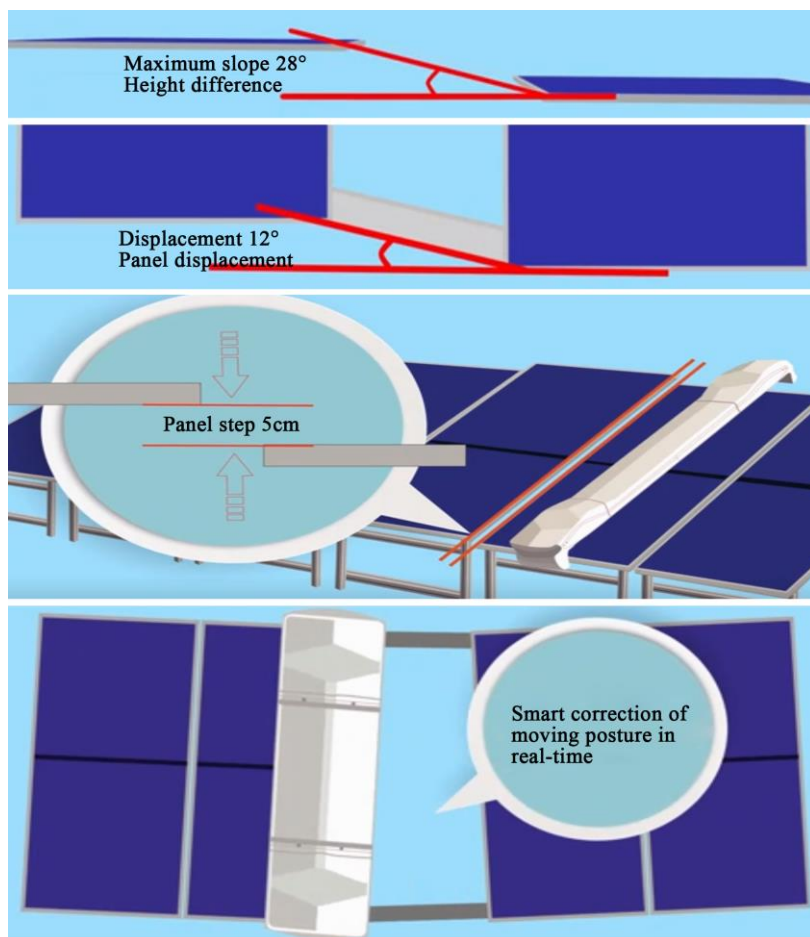

Source: This study.

Figure 4: Working performance of the cleaning robot.

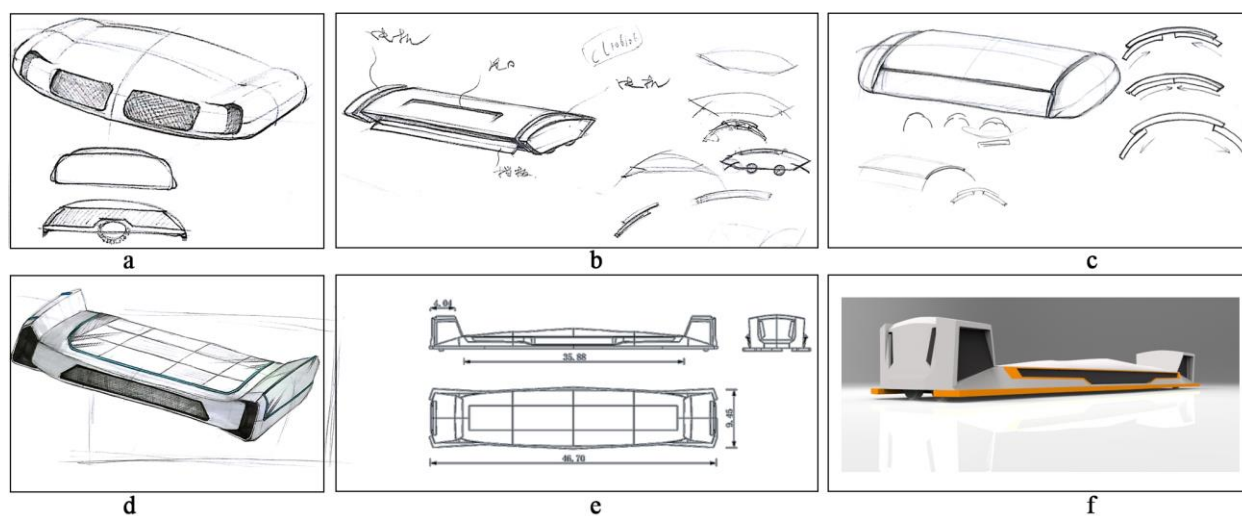

Source: This study.

Figure 5: Design of solar panel cleaning robot to prevent overturning by wind.

Convenient to transportation design

The shell of the original solar panel cleaning robot is made of rigid plastic processed by plastic suction process. The shell is divided into upper, middle and lower segment three parts. The whole is an axisymmetric model, that is, the upper and lower segments have the same modeling structure, while the middle part is basically a straight line segment without special structure. In the transportation process of the robot, the shell and the internal mechanical structure are transported separately. The internal mechanical structure is mostly rigid body. The robot with a span of more than 4 meters takes up a larger space, and the shell part is thin. Separate transportation can prevent the shell from crushing and damaging. At the same time, the shell is divided into three sections, which can appropriately save the occupied space during transportation. The Symmetrical structures can be transported in the form of stacking. However, there are some special convex and concave structures in the upper and lower sections, which can not save space very well. Therefore, the transportation of the original solar panel cleaning robot is not very convenient.

In the new design, the shell is redesigned from the original hard plastic material to flexible material. The robot shell is assembled on site. The flexible material can be folded and transported, which is very convenient. The design scheme is shown in Figure 6. Figure 6a shows the overall shape and material effect details of the design scheme; figure 6b shows the three views and the equal side view of the design scheme.



Source: This study.

Figure 6: Design scheme of solar panel cleaning robot convenient to transportation.

However, although flexible materials can make transportation more convenient, due to the flexible materials easy to deform, it is difficult to form a certain shape. In order to further solve this problem, a support scheme with a certain shape under the flexible material is designed, and the whole flexible shell is supported by the corresponding shaped bracket. At the same time, considering the beauty and streamline of the overall shape, the shape imitates the streamline shape of the car, and the height of both sides is slightly lower than that of the middle part. The internal structure scheme is a fishbone like structure. A main support rod is designed, and then the bent bracket is fixed on both sides. The overall shape looks like a fish skeleton. This design can make the flexible material have more support points and form a fixed shape. Each supporting rod is connected by inserting, which is easy to disassemble and assemble. The internal structure is shown in Figure 7. The overall internal frame is built to look like a fish skeleton. The poles on both sides of the framework run through all the supports to stabilize the main body. The bracket forming the shell shape is inserted into the prefabricated holes on both sides of the main beam of the internal structure to fix the whole shell shape. At the fixed node of the bracket, the opening is positioned on the flexible material, and the metal ring is used to lock the edge. During the installation, the hole is inserted into the small stud on the fixed node, and then the nut is used to compress and fix, so that the whole flexible shell is in the tension state. The material can be made of elastic textile fabric, and the gap between the fabrics has certain wind ventilation effect.

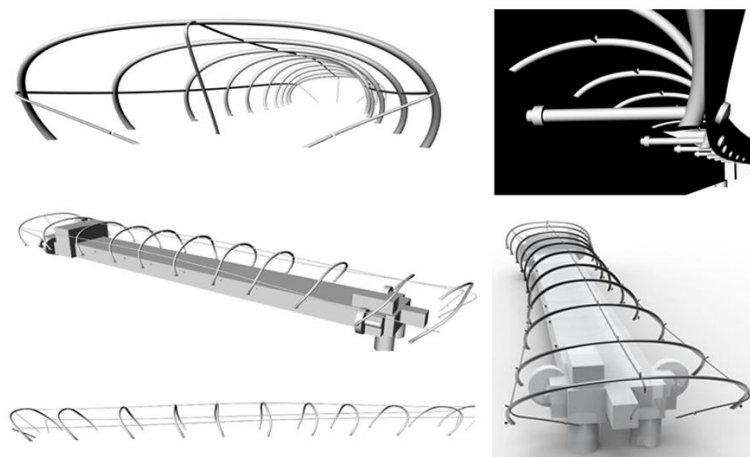

Source: This study.

Figure 7: Shell support structure of solar panel cleaning robot convenient to transportation.

Design adapted to new energy sources

The solar panel cleaning robot walks back and forth on the solar panel. In the original scheme, the power required for the robot to walk on the solar panel is provided by its own power carried, which is rechargeable battery pack. Due to the limited number of batteries carried, generally the robot needs to return to the fixed charging position for charging after working for a period of time, which wastes working time, reduces work efficiency. To improve the performance of the robot for its working environment, if it can make full use of solar energy to provide power for its own walking, it will be a good choice. Therefore, the power supply mode and energy source of the solar panel cleaning robot are improved. A flexible optical fiber panel is designed on top of the robot shell, which can not only provide walking power for the robot, but also not reduce the overall beauty of the robot. Therefore, an improving redesign of the shell shape is done. In the design, the flexible solar fiber panel as shown in Figure 8 needs to be embedded in the top of the solar panel cleaning robot shell. Considering the beautiful appearance and the installation of flexible optical fiber panel, the unnecessary lines are simplified as much as possible, which is brief but not simple.



Source: Taobao picture.
Figure 8: Flexible solar fiber panel.

Figure 9 shows three design schemes, which can better integrate flexible solar panels, so that the robot can constantly replenish energy while working. The design of plug-in block, pressure plate or sticker is used to fix and compress the edge strips around the flexible solar panel, which is convenient for disassembly. The modular design can save the production cost.

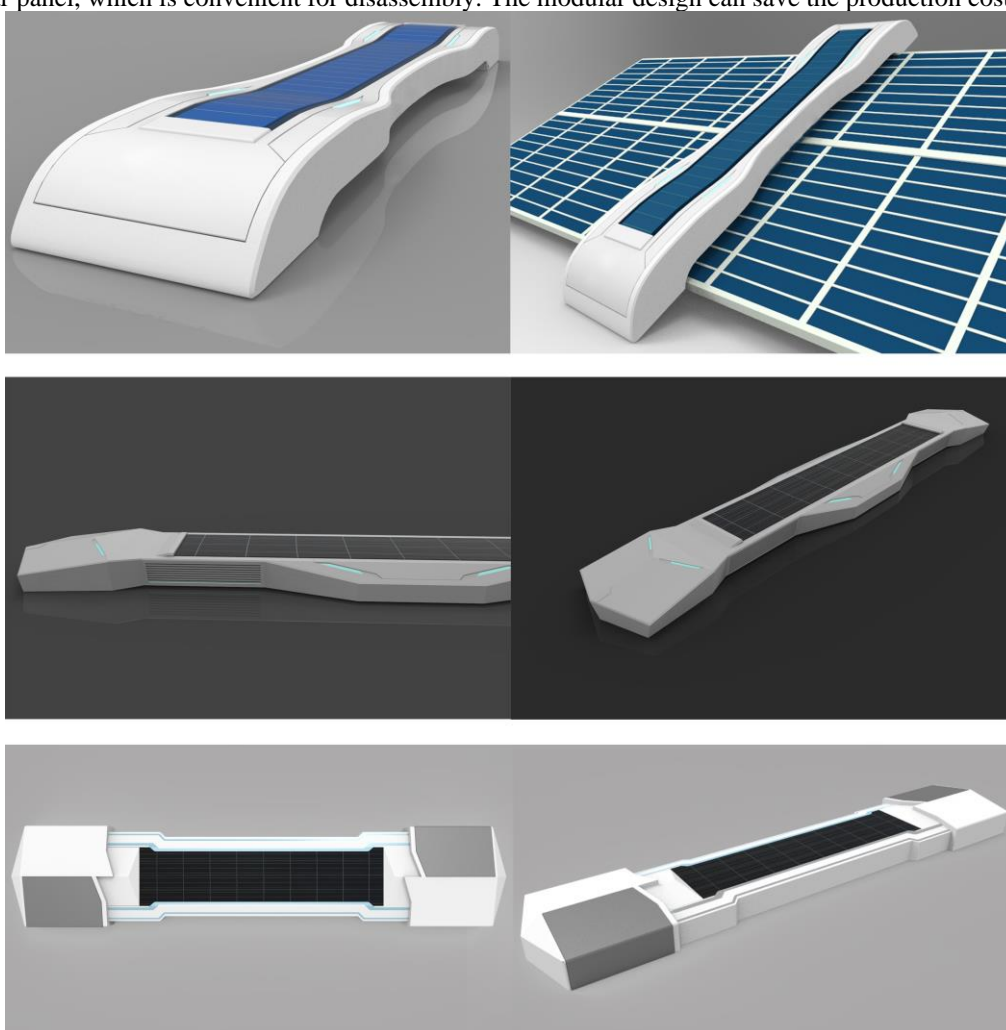

Source: This study.
Figure 9: Three design schemes of solar panel cleaning robot.

THE ROLE OF BIG DATA AND ARTIFICIAL INTELLIGENCE IN DESIGN

Multi-functional intelligent products design

With the advent of "industry 4.0" and the era of big data, the change of products is becoming more and more intense, and has evolved into the main melody of all walks of life, "the only constant is change" (Jyh-Rong Chou., 2020). The innovation ability of traditional industries is constantly improving, and the development opportunities are increasing. Under the influence of technologies such as artificial intelligence and virtual reality, industrial design ushers in great development opportunities (Jia, L. B. *et al.*, 2020). More and more multi-functional intelligent products appear, but how many of the functions of the products are popular with people and have high utilization rate? There are cognitive differences in modeling images. Professor Su J. N. and Zhang, X.X. *et al.* (2016) have carried out entropy evaluation research on them. The research points out that due to the differences of cognitive environment, knowledge background and experience, users, designers and engineers have different image cognition of products. Therefore, it is necessary to integrate the three modeling entropy evaluation models based on image cognition to determine the product shape. Many scholars all over the world have carried out research on intelligent product design (Pereira Pessôa, M.V. *et al.*, 2020; Chen, X. *et al.*, 2019). To judge the functional practicability of intelligent products, we should combine intelligent products with big data platform based on real feedback in actual use, collect and analyze objective utilization data and process data in the design process through big data platform, and guide the functional design of multi-functional products. This will be the research hotspots in the future.

Big data as a new design factor

As one of the "national big data strategy" of the "13th five year plan", China's big data industry is in a period of rapid development, and new products and services are constantly launched. The significant trend of big data development makes data become a new "factor of production", leading the design and development of products. In the era of big data, although 59% of the data is invalid, 70% - 85% of the data is too complex, 85% of the enterprise data architecture can not meet the demand of data volume and complexity growth, and 98% of the enterprises can not provide the correct information for the business in a timely and accurate manner. However, the application of big data is constantly studied in various fields, such as performance means and design methods or product functions in design are constantly absorbing the advantages of big data and designing more, newer and more market-oriented products from the perspective of user experience. The emergence of big data opens great opportunities. Big data may provide reference answers for human beings to make decisions through mining and analytical processing, but it could not replace human thinking. (M.Chen, 2014)

Artificial intelligence as means or function in design

Since the birth of artificial intelligence, the theory and technology are increasingly mature, and the application fields are also expanding. It can be imagined that the scientific and technological products brought by artificial intelligence in the future will be the "container" of human intelligence. Big data can be regarded as one of the three carriages driving artificial intelligence, which can provide power source for the development of artificial intelligence. The important thing of big data is the whole process of data processing, mining, analysis, visualization and application, and data source is the primary problem. The combination of artificial intelligence and design is mainly reflected in two aspects: the development of artificial intelligence products and the application of artificial intelligence technology in product design, such as intelligent sweeping robots and intelligent bracelets in life are both artificial intelligence products. For example, a chair designed by Stark relying on artificial intelligence technology during the Milan Design Week 2019 reflects the application of artificial intelligence technology in product design for the first time. However, recently, Sun L. Y.'s team of Zhejiang University (2020) conducted a study on the current situation and development trend of human centered intelligent product design, pointing out that the field of artificial intelligence is facing an important transition from technology driven to people-oriented, and the application of artificial intelligence should assist and enhance human beings, rather than replace human beings.

Big data, artificial intelligence and design

In summary, the application concept of big data in various stages of product design has been basically mature. For example, in the demand analysis stage, demand information extraction, demand function transformation, demand preference analysis and demand trend prediction can be carried out through data conversion and collection; in the scheme generation stage, function mapping, scheme optimization and overall innovation can be achieved through data storage and processing; in the scheme evaluation, product performance acquisition, index weight analysis and scheme selection evaluation can be completed through data analysis and data interpretation. The design based on big data can focus on real people and real events, pay attention to product service, use environment and information feedback, which will help to better understand the essential needs of users for products in the whole product R & D process. The design oriented to users' essential needs can adapt to the development and progress of human beings and society. However, the specific application and solution of data-driven product innovation design need to be studied. For the development of artificial intelligence products, data is the underlying foundation for the learning ability of intelligent products. At the same time, artificial intelligence products should also become the source of supporting the continuous enrichment and improvement of big data. The collection, storage and upload of user use information by artificial intelligence products will help enrich and optimize big data resources. Therefore, in the design of intelligent products, it is necessary to collect and return some objective data in the user's use of the product as much as possible on the premise of protecting the privacy of users. In addition, in view of the differences between the machine thinking of artificial intelligence and the design thinking of human beings, the design process can not completely rely on big data and AI technology, and the participation of designers cannot be shielded to think about user needs sensibly, strive to achieve the human centered intelligent product design.

CONCLUSION

In summary, with the continuous development of new energy and new technology, new demands and automation products are constantly emerging. More and more fields can liberate human hands and realize mechanization. Combined with the problems found in the production, transportation and use of products, solutions are given respectively, and some solutions can be combined to solve multiple problems comprehensively. For example, vent can be opened on the side of the shell embedded with flexible solar panel, and the shell surface with support structure and flexible material can also be attached with flexible solar panel. Problem driven design, in the future use of solar panel cleaning robot, there will be more room for further development and improvement, such as the application of artificial intelligence technology, which can realize robot information feedback, big data platform can support the construction of integrated management system, timely tracking and discovering the use of robots and problems, and even remote maintenance, It will be the direction of future research. The improved design of the shell combined with the technology of the cleaning robot provides a reference for the upgrading of the solar panel cleaning robot, and can also be applied in the design of similar products.

ACKNOWLEDGMENT

This work is partially supported by grant 2018SJZDA015 and 2019SJZDA118 of the Major project of Philosophy and Social Science research in colleges and universities of Jiangsu Province, China. And it is also partially supported by the 2019 "Challenge Cup" competition support cultivation project "Research on design of innovative multi angle elderly care equipment and rescue system" (TZ20190018) of Nanjing Institute of Technology, China.

REFERENCES

- [1] Bernard, A.R., Eriksen, R., Horenstein, M.N. *et al.* (2018). Dust settles, we don't: The electrodynamic screen—A self-cleaning technology for concentrated solar power mirrors and photovoltaic panels. *MRS Energy & Sustainability*, 5, 11, 7p. doi: <https://doi.org/10.1557/mre.2018.12>
- [2] Chen, M., Mao, S., & Liu, Y. (2014). Big data: A survey. *Mobile Networks and Applications*, 19(2), 171-209. doi: <https://doi.org/10.1007/s11036-013-0489-0>
- [3] Chen, X., Xue, L. (2019). Interaction design of elderly-oriented intelligent home products based on QFD/TRIZ, *Packaging Engineering*, 40(20), 74-80. doi: 10.19554/j.cnki.1001-3563.2019.20.012 (in Chinese).
- [4] Fan, X., Teng, L., Liu, M., Junkai, L., Zhang, S., & Cao, J. (2018, October). A Research on an Intelligent Line Device for Increasing the Utilization of Solar Energy. In *2018 IEEE International Telecommunications Energy Conference (INTELEC)* (pp. 1-4). IEEE. doi: 10.1109/INTLEEC.2018.8612350
- [5] Hassan, M. U., Nawaz, M. I., & Iqbal, J. (2017, November). Towards autonomous cleaning of photovoltaic modules: Design and realization of a robotic cleaner. In *2017 First International Conference on Latest trends in Electrical Engineering and Computing Technologies (INTELLECT)* (pp. 1-6). IEEE. doi: 10.1109/INTELLECT.2017.8277631
- [6] Jia, L. B., Xue, X. Y. (2020). Natural interaction design of intelligent rehabilitation products under the user's instinct, *Packaging Engineering*, 41(10), 101-107. doi: 10.19554/j.cnki.1001-3563.2020.10.016 (in Chinese).
- [7] Chou, J. R. (2020, July). What Would Be the Next Design Evolution Under the Auspices of Industry 4.0? In *International Conference on Human-Computer Interaction* (pp. 28-45). Springer, Cham. doi: https://doi.org/10.1007/978-3-030-49788-0_3
- [8] Patil, P. A., Bagi, J. S., & Wagh, M. M. (2017, August). A review on cleaning mechanism of solar photovoltaic panel. In *2017 International Conference on Energy, Communication, Data Analytics and Soft Computing (ICECDS)* (pp. 250-256). IEEE. doi: 10.1109/ICECDS.2017.8389895
- [9] Pessôa, M. V. P., & Becker, J. M. J. (2020). Smart design engineering: a literature review of the impact of the 4th industrial revolution on product design and development. *Research in Engineering Design*, 31:175–195. doi: <https://doi.org/10.1007/s00163-020-00330-z>
- [10] Riawan, I. P. G., Kumara, I. N. S., Partha, C. G. I., Setiawan, I. N., & Santiari, D. A. S. (2018, October). Robot for cleaning solar PV module to support rooftop PV development. In *2018 International Conference on Smart Green Technology in Electrical and Information Systems (ICSGTEIS)* (pp. 132-137). IEEE.
- [11] Said, A., Alaoui, S. M., Rouas, Y., Dambrine, G., Menard, E., Boardman, J., & Barhdadi, A. (2018, December). Innovative Low Cost Cleaning Technique for PV Modules on Solar Tracker. In *2018 6th International Renewable and Sustainable Energy Conference (IRSEC)* (pp. 1-4). IEEE.
- [12] Su, J. N., Zhang, X. X., Jing, N., & Chen, X. (2016). Research on the entropy evaluation of product styling image under the cognitive difference. *Journal of Machine Design*, 33(3), 105-108. doi:10.13841/j.cnki.jxsj.2016.03.022
- [13] Sun, L. Y., Zhang, Y. Y., Zhou, Z.B., Zhou, Z.H. (2020). Current situation and development trend of intelligent product design under the background of human-centered AI, *Packaging Engineering*, 41(02), 1-6. doi: 10.19554/j.cnki.1001-3563.2020.02.001 (in Chinese).
- [14] Zhang, H., He, B., Guan, Y., Ma, M., Li, Y., & Song, S. (2017, July). Assessing the potential for global solar energy utilization. In *2017 IEEE International Geoscience and Remote Sensing Symposium (IGARSS)* (pp. 1618-1621). IEEE. doi: 10.1109/IGARSS.2017.8127283
- [15] Zhang, L., Yu, S. S., Fernando, T., Iu, H. H. C., & Wong, K. P. (2019). An online maximum power point capturing technique for high-efficiency power generation of solar photovoltaic systems. *Journal of Modern Power Systems and Clean Energy*, 7(2), 357-368. doi: <https://doi.org/10.1007/s40565-018-0440-2>

Research on Mode and Risk Prevention of Agricultural Supply Chain Finance based on E-commerce

(Full Paper)

Qiming Zheng, Nanjing Polytechnic Institute, Nanjing, China, 13813038069@163.com
Mingxuan Zheng, Northeast Forestry University, Harbin, China, ZhengMX1999@126.com
Yaqin Dou*, Nanjing Institute of Technology, Nanjing, China, douyq@njit.edu.cn

ABSTRACT

The rapid development of e-commerce has a profound impact on agricultural supply chain finance (ASCF), which is of great significance to enhance the resilience of agricultural economic development, realize the poverty alleviation effect of agricultural enterprises, integrate agricultural supply chain resources and solve the financing difficulties of agricultural enterprises. We analyze the participants and functions of the ASCF mode based on e-commerce, and the contract framework of various participants when they operate in the ASCF platform in this paper. Based on the agricultural industry chain, we analyze the operation process of accounts receivable financing mode, inventory financing mode and prepayment financing mode based on E-commerce. Finally, in view of the natural risks, credit risks, logistics risks, technical risks and legal risks that may exist in ASCF based on e-commerce, the corresponding countermeasures are put forward from the aspects of dispersing natural risks, building digital credit risk assessment system, building agricultural logistics network system, improving technical risk monitoring system, and improving relevant laws and regulations policy recommendations.

Keywords: ASCF, e-commerce, digital technology

*Corresponding author

INTRODUCTION

The healthy and sustainable development of agricultural industry is closely related to the strong support of financial capital. Sufficient funds and financial support can help farmers and SMEs to improve production and operation conditions and performance. However, under the traditional credit mode, limited by the inherent weaknesses of agricultural enterprises such as long production cycle and small scale, financial institutions are difficult to meet the financing needs of farmers. Financing is difficult, expensive and slow, which are the common difficulties of agricultural enterprises. As a financing service mode close to the agricultural industry chain, ASCF relies on the credit guarantee of the core enterprises in the supply chain to help the SMEs in the supply chain obtain financial resources. Especially with the promotion of e-commerce technology, the high integration of agricultural supply chain and modern finance can better promote the transformation, upgrading and innovation of agricultural enterprises, which is of great significance to provide financial support to promote the implementation of Rural Revitalization Strategy.

ASCF is the specific application of SCF in the agricultural field. It is generally believed that it is to bind the interests between upstream and downstream enterprises and farmers, pledge intangible assets such as creditor's rights assets, inventory physical assets or intellectual property rights of agricultural enterprises, and take the income of these pledge as repayment, to providing financing services for supply, production and marketing of SMEs in the supply chain. ASCF can not only encourage poor farmers to expand production to improve their income, but also help them to get rid of financing difficulties, which has become one of the most effective micro models of rural financial poverty alleviation (Guo, Gu, & Yang, 2020). In recent years, with the promotion of Rural Revitalization Strategy, ASCF has been paid more and more attention by governments at all levels. In 2017, the general office of the State Council issued "Guidance on actively promoting innovation and application of supply chain". It is further proposed to innovate the system of agricultural industrial organization and develop the ASCF services. In April 2019, the general office of the CPC Central Committee and the general office of the State Council encouraged enterprises to rely on accounts receivable, supply chain finance, franchise and other channels for financing in the guidance on promoting the healthy development of SMEs. Although the government has been formulating various preferential policies to encourage agricultural development, due to the current low degree of agricultural industrialization, the relevant laws and regulations have not yet been established and perfected, and the policies are not comprehensive enough, the development is still relatively slow, and its innovative application and comprehensive risk prevention and control capabilities need to be improved, and there is a certain gap with the financial security required by the Rural Revitalization Strategy (Liu, 2019).

In the first half of 2020, online retail sales amounted to 5150.1 billion yuan, of which grain, oil and food accounted for 7.5%, up 40.7% year-on-year in China. The rapid development of e-commerce has not only changed the rural lifestyle, but also had a profound impact on agriculture. At the same time, e-commerce also promotes the close combination of traditional offline SCF and e-commerce platform, and promotes the online development speed of SCF. In recent years, scholars began to pay attention to the application of e-commerce in SCF. Steven (2000) proposed that B2B e-commerce market and financial field would be integrated, and the resulting business model would have a profound impact on the financial field and related services. Heng

(2001) believed that finance, banking and other fields can would bring subversive innovation and change to the development of e-commerce. Li (2007) proposed that developing supply chain finance business based on the third-party e-commerce platform can reduce financial risks and solve financing difficulties for small and medium-sized enterprises. Li (2011) proposed to analyze the E-order and e-warehouse receipt supply chain financial model based on e-commerce platform. Dou & Zheng (2019) studied that B2B supply chain finance is the business innovation of e-commerce enterprises relying on the new generation of information technology, and analyzed the theoretical framework, constraints and governance strategies of B2B supply chain finance. Zheng *et al.* (2019) thought that B2B supply chain finance was the business innovation of e-commerce enterprises in the field of supply chain finance, and discusses the operation mode and risk prevention of B2B supply chain finance.

To sum up, although the application of e-commerce in the field of supply chain finance has begun to attract scholars' attention, the application of supply chain finance based on e-commerce platform in agriculture has not been paid attention to. Therefore, based on the above research background, we analyze the significance of developing ASCF based on e-commerce, explores the operation design of ASCF mode, and studies the innovation of ASCF based on e-commerce platform in this paper. Finally, in view of the various risks that may appear in the specific application of ASCF, we further discusses the risk management mechanism of ASCF with the current situation of China in this paper, and provides new solutions for the financing difficulties of agricultural SMEs and farmers, so as to promote the development of ASCF and accelerate the process of Rural Revitalization Strategy.

THE SIGNIFICANCE OF DEVELOPING ASCF BASED ON E-COMMERCE

Driven by e-commerce and digital technology in China, ASCF has entered a new era, showing a new business form of big data, Internet of things, blockchain and artificial intelligence. ASCF based on e-commerce can effectively gather the advantageous resources such as risk control, credit enhancement, capital and so on under the collaborative effect of a variety of digital technologies, and realize the complementary advantages of multiple entities through precise connection, so as to achieve the effect of "1+1>2". In particular, the collaborative cross of digital technologies in the e-commerce platform will help agriculture break through the "information island" and technology bottleneck, which may provide credit support and risk control guarantee for more and more agricultural SMEs, and meet the capital needs of their production and operation.

Alleviating the financing difficulties of agricultural enterprises

Under the traditional mode, commercial banks and other formal financial institutions have higher financing conditions for small-scale agricultural enterprises and farmers, which is difficult to become a major help to make up for their financing demand gap. The core of supply chain finance is to speed up the capital flow of supply chain and help the upstream and downstream competitive small and medium-sized enterprises to develop. The performance measurement standard is more based on the strategic income and the reduction of industrial transaction cost (Wu *et al.*, 2016). The in-depth application of ASCF has played an important role in alleviating the plight of agricultural financing. Especially, with the continuous innovation of e-commerce and digital technology, it brings new opportunities for agricultural enterprises and farmers to apply ASCF. Due to the application of blockchain technology, big digital, cloud computing and other technologies, participants can conduct open and transparent information exchange and financial transactions on the digital financial platform. In this way, the integration of agricultural industry with SCF, e-commerce, and digital technology can greatly avoid the problems of information asymmetry, rigid processes, and expensive costs caused by traditional financial support for agriculture, and improve agricultural and rural finance supply efficiency and farmers' credit level. ASCF based on e-commerce has become an important way to make up for the current financing gap of small-scale farmers and to revitalize the development of rural industries.

Enhancing the resilience of agricultural economic development

Agricultural economic resilience means that multi-level entities such as farmers and rural areas can flexibly respond to the risk of loss caused by economic shocks, which is closely related to the agricultural economic foundation (Yu, & Zhang, 2019). In the process of agricultural production and management, it is inevitable to be affected by various natural factors, environmental factors and social factors. Therefore, improving the resilience of the agricultural economy to deal with various risks and uncertainties has become an important part of revitalizing the modern agricultural industry. Good economic support helps to form the resilience of farmers to respond to risks and enhance the resilience of agricultural economic development. For example, the Agricultural Bank of China developed the "Hui Nong e-Tong" financial service platform. As of 2019, the loan balance reached 101.84 billion yuan, "Hui Nong e-payment" covered 7.16 million farmers, and "Hui Nong e-commerce" online merchants exceeded 2.67 million (Yang, & Zheng, 2020). ASCF integrates logistics operations, business operations and financial management. With the promotion of digital technology, all information and elements are glanced on the digital platform. The government can provide financial support and production materials for farmers in the downstream of the supply chain based on the digital information database, formulate reasonable preferential policies for small and medium-sized agricultural enterprises, and financial institutions combine big data and offline credit assessment to promptly inject funds. With the help of these supports, farmers can also have more leeway to deal with unexpected situations, so the upstream of the supply chain can also get more positive feedback. Under the modernized supply chain financing model, the development potential of the agricultural industry can be maximized, and the foundation of agricultural economic development can be consolidated, the resilience of agricultural development can be enhanced, and the strategy of rural revitalization can be promoted.

Realizing the poverty reduction effect of agricultural enterprises

Promoting the development of agricultural industries in impoverished areas and the continued increase in income of poor people are important elements of the rural revitalization strategy. In 2019, the central government made clear that it is necessary to do a good job of connecting poverty alleviation and rural revitalization strategies. This puts forward higher requirements for strengthening supply chain financing and helping rural industries to be revitalized. In the practice of tackling poverty, farmers are often in a relatively weak position due to factors such as lack of collateral, weak credit guarantee capabilities, and asymmetric information. ASCF is inclusive. On the one hand, ASCF can break through the plight of credit constraints, and an effective credit linkage mechanism has been established between the main bodies of the supply chain to coordinate the relationship between all parties. It has low risks, low costs, The advantages of fast financing and other advantages have become an important means to solve the financing dilemma of agricultural small and medium-sized enterprises and individual poverty-stricken rural households, thereby promoting the poverty alleviation process. On the other hand, ASCF can achieve poverty reduction through industrial poverty alleviation. Through the big data analysis of the income level, loan demand, credit level and other information of farmers registered on the digital platform, a shared database of the government, financial institutions and other subjects is established to provide personalized choices for poverty alleviation targets (Yang, &Zheng, 2020). Each subject can provide timely support for construction and financial assistance to help agricultural small and medium-sized enterprises survive and drive the surrounding people to further reduce poverty and get rid of poverty, and be closer to the overall goal of completing the rural revitalization strategy.

Integration of agricultural supply chain resources

The important content and key areas of the rural revitalization strategy are agricultural industry innovation and reform. In the current wave of agricultural industrialization, based on big data, artificial intelligence, cloud computing and block chain, with the development of modern technologies, agricultural enterprises cross industries , Cross-regional and cross-domain diversified management will become the norm, which has a profound impact on the industrial form and development model of modern agriculture, making the internal links of the main bodies of the agricultural supply chain closer, and also for ASCF and industrial chain finance. Development provides technical conditions. The application of digital technology has spawned the emergence and development of digital financial platforms. The dominant enterprises and a series of small and medium-sized enterprises in the agricultural industry chain are concentrated on the platform. Their production factors, real trade conditions, inventory and other information are all stored on the platform and passed Cloud computing forms big data for each participant in the supply chain to view and reference, maximally connect logistics, business flow, information flow, and capital flow in the supply chain to achieve real-time sharing; At the same time, the integration of the dominant resources of each subject, through the professional division and cooperation (Lin, 2019), provides a guarantee for the better development of ASCF and the realization of Rural Revitalization Strategy..

OPERATIONAL DESIGN OF ASCF BASED ON E-COMMERCE

The penetration of e-commerce technology has brought huge changes to ASCF. The various advantageous resources attracted by the e-commerce platform are empowered by technologies such as blockchain, the Internet of Things, and big data to bring diversified services to the financing customer groups in the ASCF. The financing process of agricultural SMEs has become more efficient and convenient.

Participating entities and their functions

E-commerce platform

E-commerce platform is the center of ASCF. It is based on technologies such as big data, cloud computing, artificial intelligence and blockchain. With its own logistics, information flow, business flow, and capital flow, it integrates a large amount of trade information on the trading platform of various entities and provides customers with comprehensive services. This kind of digital platform should include core modular services, good interface and highly complementary resources (Spannoletti, Resca, & Lee, 2015), so as to build a trading place for agricultural participants, reduce friction in the process of factor flow, simplify workflow, reduce information cost, achieve reasonable risk pricing and risk control, which is conducive to the complementary resources of each subject. The platform builds a trading venue for agricultural participants, which can reduce friction in the flow of elements, simplify work procedures, reduce information costs, and achieve reasonable risk pricing and risk control, which is conducive to the complementary resource advantages of each entity.

Agricultural supply Chain Enterprises

In the entire agricultural supply chain, it is the small and medium-sized agricultural enterprises and individual farmers that are in the main position of financing demand. Although the size of small and medium-sized enterprises, such as personnel size, operation scale, and capital scale, are relatively small economic units, they occupy an important position in China's national economy. Their flexible operating mechanisms and market adaptability have become an important force for promoting economic system reform. Individual farmers are self-cultivating farmers who are engaged in agricultural production and management activities in the form of household contracting management. Since ancient times, they have played an irreplaceable role in ensuring people's livelihood. Due to its own limitations, the financing needs of small and medium-sized enterprises and farmers have conflicted with the actual painful and difficult financing needs, and has always been in a weak financing position. The emergence of ASCF has compensated to a certain extent for the traditional financial institutions' structural deficiencies in financing services. The vertical aspect is conducive to close contact with enterprises, farmers and consumers, reducing the friction costs of various links, and the horizontal aspect is conducive to refinement. Industrial division

of labor and the integration of fragmented processes have laid a solid foundation for the development of agricultural industrialization.

Service Provider

Service providers mainly include financial institutions, logistics companies and other service providers. Financial institutions such as commercial banks and P2P platforms have strong advantages in terms of funds and customer sources, and have rich experience in risk management and control, which can provide financial products and capital support for financing demand subjects. The third-party logistics company is the most important link in the offline closed loop, and is essential for the smooth operation of the entire supply chain. Logistics companies provide comprehensive third-party logistics services such as collateral storage, supervision services, warehousing services, logistics and transportation services, and build a bridge between financial institutions and enterprises. Other service providers mainly include two types. One is to provide technical support and daily maintenance and repair services for building platforms relying on big data, cloud computing, artificial intelligence, block chain and other technologies, which seems to be out of the supply chain financing. But an indispensable subject. The second is government departments, which generally guide and support supply chain enterprises by formulating policies.

Operation contract

ASCF mainly relies on industry focus enterprises and other credit guarantee service entities with superior resources in the supply chain to provide a service mode for financing small and medium-sized agricultural enterprises in the upstream and downstream of the agricultural industry chain. Its operation mainly depends on the following four sets of contracts: First, the e-commerce platform signs contracts with agricultural industry chain enterprises, financial institutions, logistics companies and other service departments. The platform provides trading venues for various participating entities. Agricultural enterprises conduct order issuance, contract signing, payment settlement, logistics and other transactions on the platform. Service agencies provide various services for agricultural enterprises. Each service entity operates in an orderly manner according to the rules agreed by the platform and play their own service functions. Second, the agricultural industry chain enterprises signed contracts with various service agencies. According to the treaty, agricultural industry chain enterprises submit service applications to commercial banks, third-party logistics companies, technical service providers, and government service departments. Various service agencies provide financial, logistics, transportation, warehousing, technical support, and other services for agricultural industry chain enterprises. Related services, and charge interest, service fees or commissions. Third, contracts are signed between supply chain enterprises. The upstream and downstream agricultural enterprises complete various transactions based on the purchase contract, sales contract or technology transfer contract, and the transaction information deposited on the supply chain financing platform also provides supporting data for decision-making for various service providers to provide services. Fourth, contracts are signed between relevant service providers. Financial institutions, logistics companies and government departments need technical service providers to provide technical support; financial institutions need logistics companies' agricultural product inventory information, asset valuation agencies need to assess the value of intangible assets, and government departments such as water, electricity and steam, and government affairs information. The various service entities rely on each other and interact with each other to jointly build an ASCF service network. With the advancement and development of digital technology, ASCF can rely on the logistics, information flow, business flow and capital flow in the platform to increase the transparency of transactions, improve the efficiency of supply chain financing operations, and ensure the information security of all parties to the transaction. Build a trustworthy, transparent, efficient and safe supply chain financing environment (Wen, 2019).

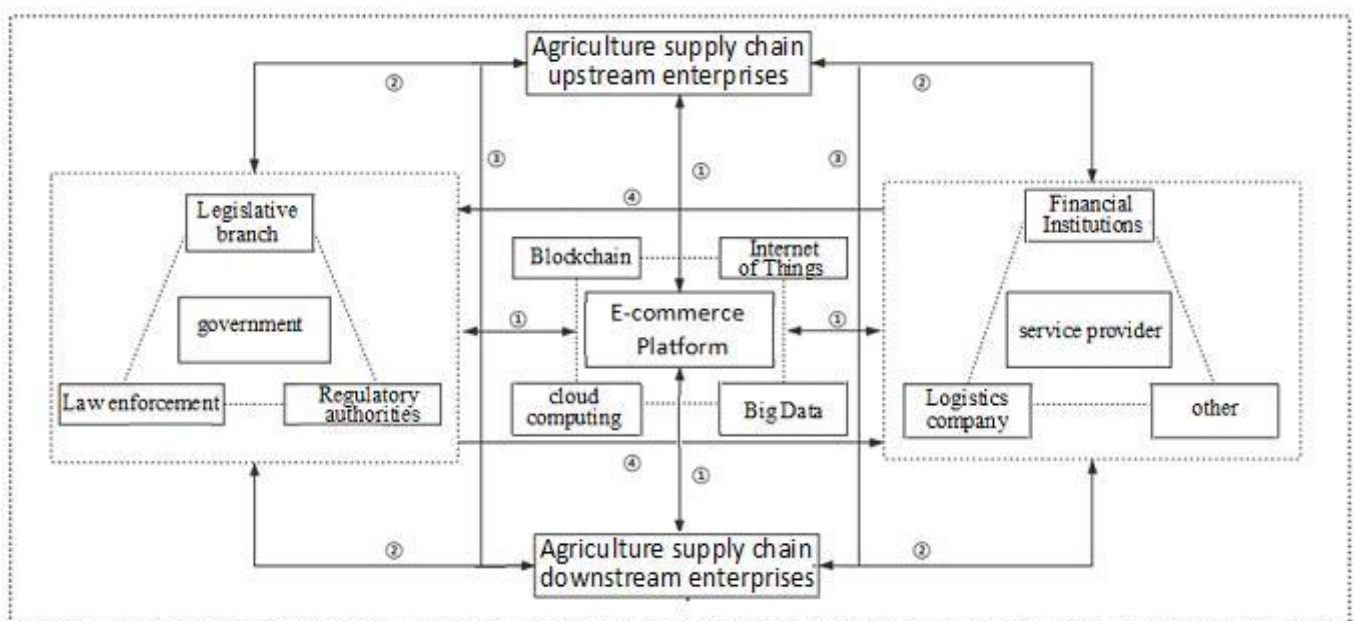

Figure 1: Network structure of ASCF based on e-commerce

MODE DESIGN OF ASCF BASED ON E-COMMERCE

With the development and popularization of e-commerce, huge changes have taken place in all walks of life in society. The innovative combination of e-commerce and traditional ASCF has also become the only way to promote the further development of ASCF and realize rural revitalization.

Accounts receivable financing mode of based on e-commerce

The accounts receivable financing mode is a financing method in which accounts receivable serve as pledges. This mode usually occurs in the sales link. Agricultural suppliers in the upstream of the supply chain have formed a large number of accounts receivable, and there is pressure on capital turnover, so they will obtain financing with the guarantee of future sales income. As shown in Figure 2, the operation flow of accounts receivable financing mode based on e-commerce is as follows.

- (1) Agricultural enterprises sign sales contracts with downstream distributors through e-commerce platforms, and apply for financing online with accounts receivable as pledges;
- (2) The e-commerce platform relies on blockchain, big data and other technologies to analyze and evaluate the true operating conditions, credit levels, and repayment capabilities of agricultural enterprises, and form reports and databases for people to consult;
- (3) Commercial banks, P2P platforms and other financial institutions use the reports provided by e-commerce platform and the customer information they own as the basis for credit investigation to determine whether the financing conditions are met;
- (4) If the financing conditions are met, the financial institution authorizes the platform payment settlement center to pay the financing amount to the enterprise;
- (5) After the receivables are due, the downstream distributors will repay the money to the platform payment settlement center, and the settlement center will repay the principal and interest of the financial institution.
- (6) When the financial institution receives the principal and interest, the current account receivable financing contract is completed.

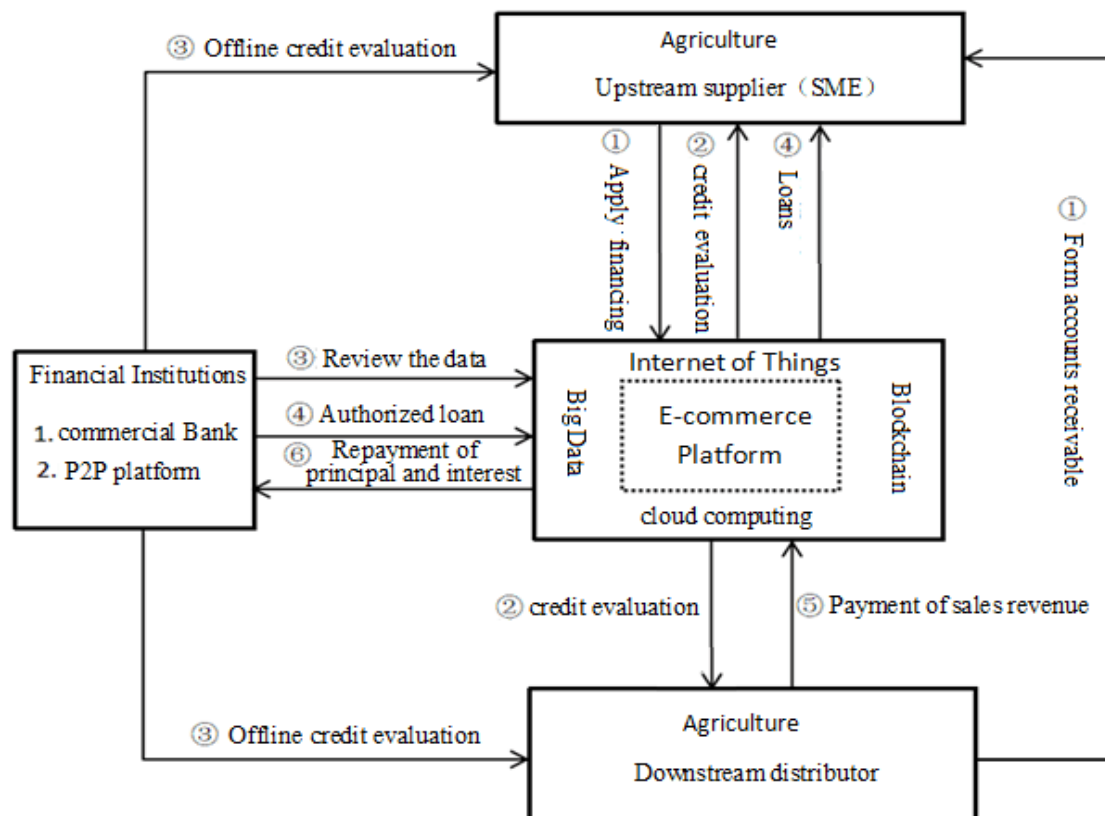

Figure 2: Operation process of accounts receivable financing mode based on e-commerce

Inventory financing mode based on e-commerce

The emergence of inventory financing model mainly stems from the small and medium-sized agricultural enterprises in the operation process, in order to ensure stability, often store a large number of primary agricultural products, production materials, etc. to cope with market fluctuations. However, this also makes it difficult for SMEs to face difficulties in capital turnover. Therefore, agricultural enterprises use inventories as collateral and use the future inventory sales revenue as a source of repayment to apply for financing from the fund supplier. The operation design of inventory financing mode based on e-commerce is shown in Figure 3.

- (1) Agricultural companies use stored inventory to send financing requests to financial institutions on the e-commerce platform;
- (2) The platform side uses big data, block chain, Internet of Things and other digital technologies to enter the inventory

- information and operation status of agricultural enterprises into the database and form an assessment report;
- (3) Financial institutions use the reports provided by the platform and the customer information they own as the basis for credit investigation to determine whether the financing conditions are met;
- (4) If the financing conditions are met, the financial institution authorizes the platform to pay the settlement center and agrees that the platform will pay the financing to the enterprise; at this time, the platform signs a pledge contract with the agricultural enterprise and requires the enterprise to transfer the inventory as pledge to the designated city Third-party logistics company;
- (5) The third-party logistics company will check this batch of inventory into the warehouse, and provide services such as inventory storage and supervision, and report the inventory status to the platform in real time;
- (6) Pay the settlement center on the platform, and the settlement center pays the principal and interest of the financial institution; if the agricultural enterprise adopts the redemption method, the third-party logistics company will return it to the enterprise;
- (7) After the financial institution receives the principal and interest, the inventory financing contract is completed.

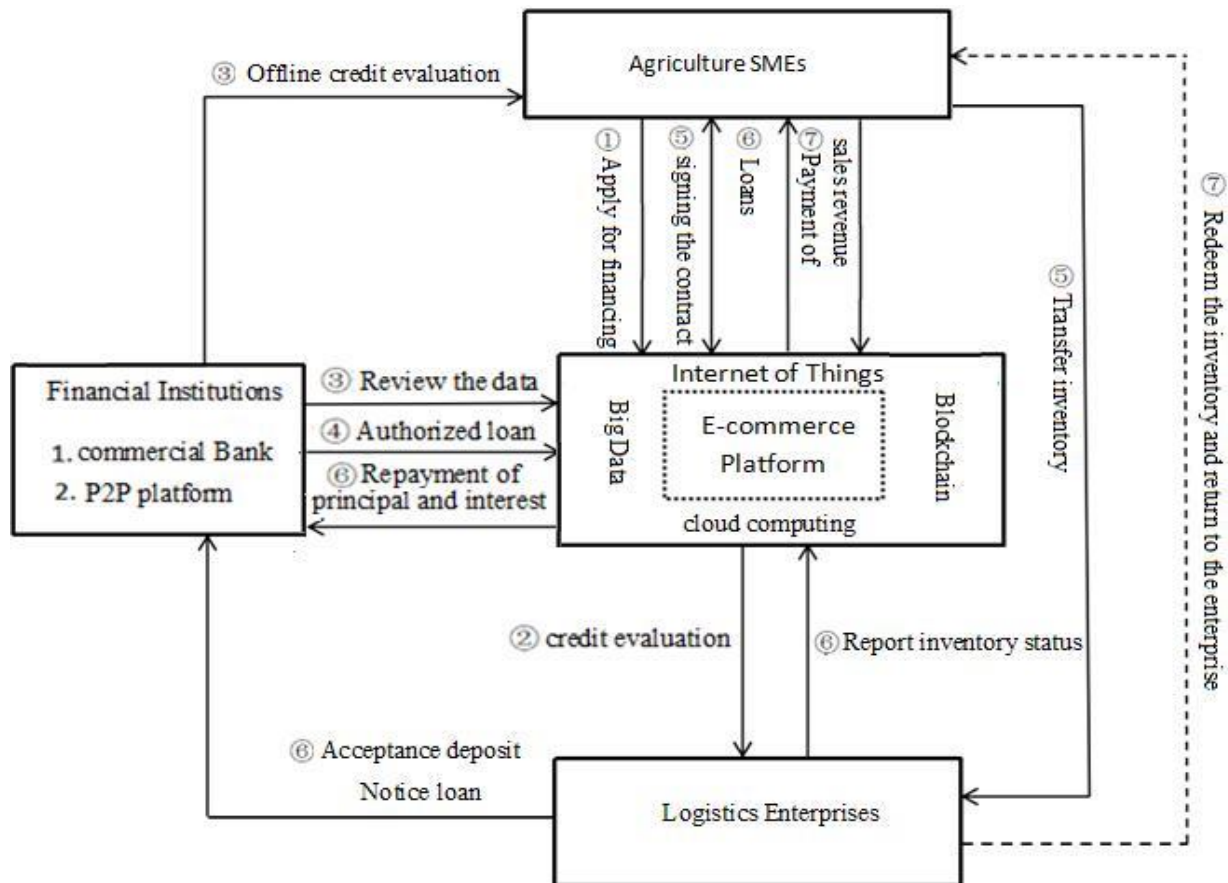

Figure 3: Operation process of inventory financing mode based on e-commerce

Prepayment account financing mode based on e-commerce

The prepaid account financing mode mainly emphasizes that agricultural enterprises sign repurchase agreements with upstream suppliers in the supply chain through digital trading platforms, in order to apply for loans from financial institutions, use prepaid accounts as collateral, and use future sales revenue as the source of repayment (Dou, Gao, & Zheng, 2020). Prepaid account financing mode based on e-commerce includes the operation steps in Figure 4.

- (1) Agricultural enterprises and upstream suppliers sign purchase and sales agreements, and use prepaid accounts as collateral to apply for prepaid account financing online;
- (2) The e-commerce platform relies on digital technology to collect relevant enterprise transaction information, conduct integrated calculation and analysis of transaction data, form an evaluation report and store it in the database;
- (3) Financial institutions use the reports provided by the platform and the customer information they own as the basis for credit investigation to determine whether the financing conditions are met;
- (4) If the financing conditions are met, the financial institution authorizes the platform payment settlement center to pay the financing money to the enterprise; the platform signs a repurchase agreement with the upstream supplier and a regulatory agreement with the third-party logistics company;
- (5) The platform informs the upstream supplier to send the goods to the designated warehouse of the third-party logistics company. The logistics company collects the goods information through the Internet of Things and other technologies, and reports the goods information to the platform immediately;
- (6) Small and medium-sized enterprises pay a certain percentage of the deposit, and financial institutions notify third-party logistics companies to give agricultural companies the right to pick up goods of corresponding value;

(7) During the stipulated period, if the downstream distributor completes the sales of the acceptance amount, the upstream distributor will repurchase the unsold goods, and this prepayment financing contract is completed.

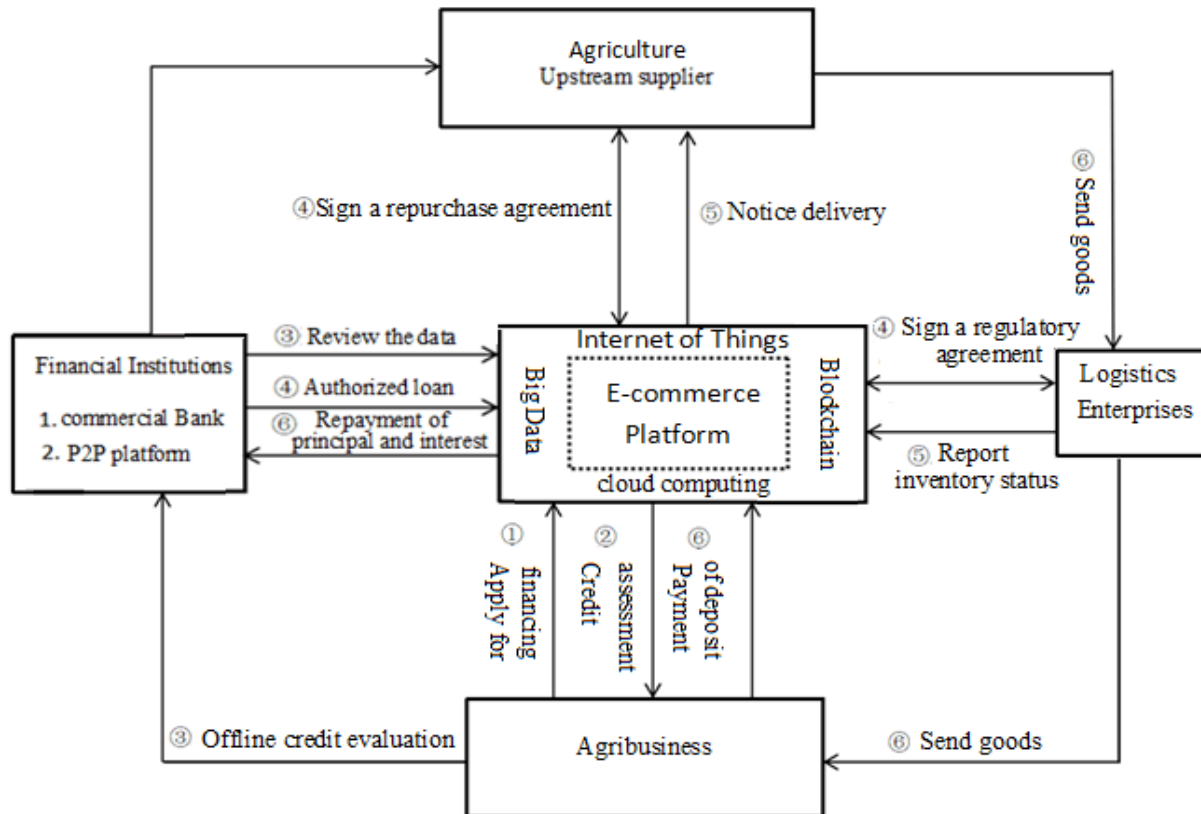

Figure 4: Operation process of prepaid account financing mode based on e-commerce

RISK ANALYSIS OF ASCF ON E-COMMERCE

At present, the application of e-commerce in the agricultural field is still in the initial stage of development. ASCF has two major attributes, industrial and financial, and has to face dual risks from industry and finance. At the same time, the integration and application capabilities of digital technology in e-commerce platforms are relatively weak, as well as the imperfect system of relevant laws and regulations, which have become important aspects that restrict the quality and efficiency of agricultural services.

Natural risks

In crop production, the main risks are natural risks. The occurrence of natural disasters is one of the important factors affecting agricultural development. My country's climate is complex and diverse, with droughts, floods, typhoons, prolonged periods of low and high temperature weather, and disease and insect disasters. After the natural disasters, farmers are unable to guarantee the supply of agricultural products to upstream suppliers due to force majeure, which will cause a series of economic losses. After farmers and small and medium-sized enterprises have lost the basis for survival, they are unable to repay credit loans provided by financial institutions such as commercial banks and Internet platforms, and financial institutions will face the risk of bad debts (Wang, 2019).

Credit risks

Due to information asymmetry, it is not uncommon for farmers to defraud loans and misappropriate funds. Compared with other collaterals, the prices of agricultural products are relatively stable and low, and they are also difficult to preserve and easy to wear. As a result, farmers lack suitable collateral, and some people tend to obtain funds through Internet financial platforms. However, these platforms lack the support of direct information in the process of loan qualification review. They can only be determined by obtaining "soft information" from social networks such as relatives and friends of the borrower, and it is not difficult to understand the frauds that exist. Moral hazards of fraudulent loans by farmers are also not uncommon (He, & Liu, 2018). After obtaining loans, some farmers will use the loans for purposes other than agricultural production, and even refuse to repay the loans after maturity, resulting in great credit risk.

Logistics risks

Affected by consumers' demand for fresh agricultural products, the transportation process has extremely high requirements on the temperature and time of the logistics link to ensure that the agricultural products will not deteriorate and rot. However, due to the fact that the development of logistics in my country is not long, and the supporting facilities are not perfect, there are many risks in the logistics link of agricultural products. In the transportation link, due to the lack of professional talents and technological innovation, unnecessary transportation costs have increased greatly. In the loading and unloading process, China

currently mainly relies on manual handling, wasting a lot of time and labor resources; and it is inevitable that damage will occur in the process of handling. In the warehousing process, because the current refrigeration technology is still relatively backward compared to foreign countries, the warehouse equipped with refrigeration equipment consumes much energy and makes a lot of noise, which affects the normal lives of surrounding residents and even pollutes the environment. In the processing and packaging process, the quality of agricultural products may be affected because the process cannot be guaranteed to be completed in a low temperature environment, and the shelf life cannot be guaranteed. In the distribution process, since the information sharing mechanism has not been fully established, there may be a lack of effective communication and exchanges with customers during the distribution process, causing some misunderstandings.

Technical risks

The e-commerce platform is the intermediary of the exchange transactions between the main bodies of the supply chain, and is the core and center of the agricultural supply chain. The platform relies on digital technology, which will inevitably produce technical risks. Technical risks include network system vulnerabilities, low professional qualities of personnel, and fraud, etc. For example, the platform is hacked or the system fails, resulting in the platform being unusable for a period of time, which will bring great economic losses; the transaction personnel are in the process of operation errors or irregular operations may also cause losses; in the process of application, review, credit, and management, the enterprise conceals its real trade background, and the platform fails to review the information errors or system failures, due to false Miscalculate the credit limit due to information, and the platform does not effectively and timely track and manage the funds after the loan is issued. Various actions may cause risks. That is, the degree of technical risk depends on the professional level of technical staff, the quality of data information, and the operation of the network system. Stationary and sharing of factor endowments (Liu, & Cheng, 2013). As the operation process of digital supply chain financing is more complicated, there are many participants, and they are interlocked. Therefore, insufficient implementation of any link may lead to business risks.

Legal risks

The current legal system related to ASCF based on e-commerce is not sound and cannot fully meet the standardized needs of related business development. The operation process is not standardized, the risk of non-compliance and non-compliance caused by non-compliance, various business operations cannot be followed and other policy and legal risks are emerging (Xu, & He, 2020). At the same time, the supervision of the ASCF platform by relevant departments is still lacking, and most of them rely on industry autonomy and lack of effective management, which also leads to certain legal risks. The supply chain financing business involves the interests of multiple parties. If there is no law to enforce the constraints, there may be industry chaos that the platform uses its own advantages to infringe on the rights of other parties.

COUNTERMEASURE OF RISK MANAGEMENT AND CONTROL OF ASCF BASED ON E-COMMERCE

Problems such as insufficient credit, weak logistics supervision, low technical ability, and lack of legal supervision have become obstacles to prevent the high-quality development of ASCF and to feed back rural revitalization strategies. In order to solve the above risks, it is necessary to implement corresponding risk management and control measures against the above problems. This article proposes the following countermeasures against the various risks that exist in ASCF, as shown in the figure 5.

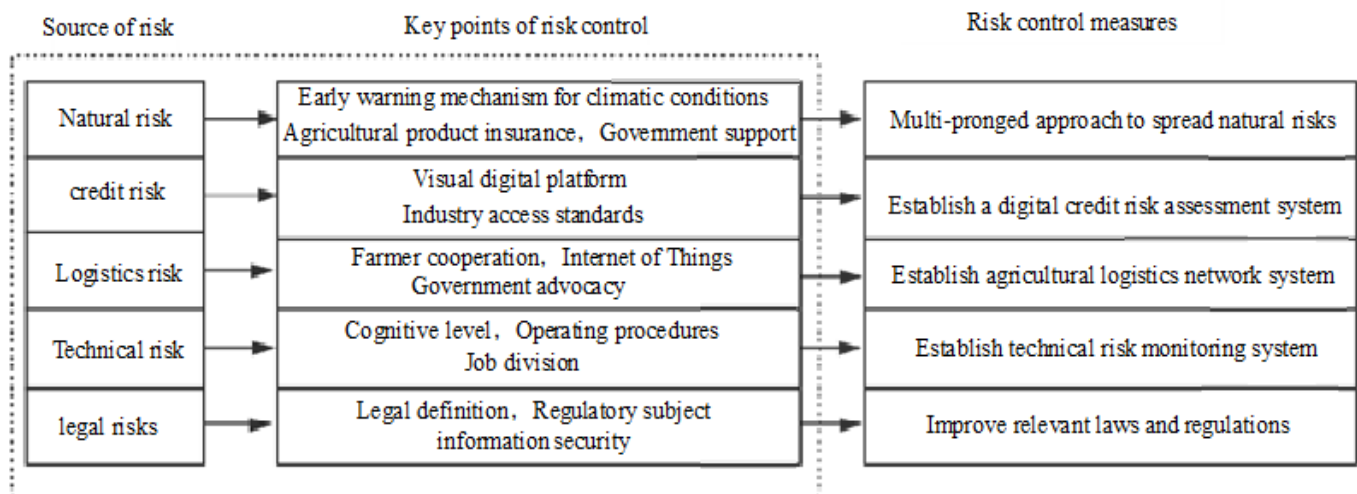

Figure 5: Risk control analysis of ASCF based on e-commerce

Multi-pronged approach to spread natural risks

In the current new stage of modernization development, the inherent vulnerability of agriculture is more obvious. Financial institutions or small and medium-sized enterprises, farmers and other entities cannot deal with possible risks alone, and multiple entities must work together to jointly resist the negative effects of natural risks. influences. Because the risks brought by force majeure such as climatic conditions cannot be completely avoided, it is mainly engaged in two aspects of pre-

prevention and post-event support. The precautions can be divided into two aspects. On the one hand, a risk control team is established within the enterprise, and a climate condition early warning mechanism is established to analyze and predict the climate at all times to increase the sensitivity to climate risks. When the climate changes abnormally, take precautions in advance to minimize the loss. On the other hand, the introduction of agricultural products insurance, guarantees and other risk protection mechanisms to diversify natural risks, to a certain extent, protect the interests of supply chain enterprises, improve the supply chain enterprises' ability to respond to natural risks. For post-event support, China has always upheld the principle of combining market leadership and government guidance. The government can contribute to the construction and improvement of agricultural infrastructure to optimize the production environment of farmers; when natural disasters and other force majeure factors occur, a subsidy mechanism is established, such as the establishment of a minimum purchase price, and government-funded acquisition of agricultural products to protect farmers' production enthusiasm; incentives Financial institutions are constantly innovating and introducing financial products suitable for small and medium-sized enterprises and farmers; they can also directly contribute to support or establish agricultural insurance companies, rural cooperatives, etc., and play the supervisory role of relevant departments, coordinate relations between all parties, and jointly undertake production operations with other entities Risks in the process, improve the level of agricultural supply chain management, participate in the maintenance of ASCF from both hardware facilities and software policies, and provide a way to solve the problems of agricultural and rural farmers, diversify risks in the development process, and promote the process of rural revitalization strategy.

Construction of a digital credit evaluation system

The most fundamental reason for the occurrence of credit risk is that the information flow is gradually reduced by each node in the supply chain circulation process, resulting in asymmetric information obtained from above and below, which creates credit risk. Therefore, on the one hand, we must use big data, Internet of Things, block chain and other digital technologies to build a visual digital platform, optimize and improve the information flow environment in the supply chain, and enhance the information liquidity, reduce the loss of information flow, and let the various users of the platform Subjects can consult information transfer information and conclude transactions through the platform database to increase transaction transparency and mutual trust between parties. On the other hand, the government should formulate relevant industry access standards, strengthen the management of credit access for agricultural supply chain entities, evaluate the enterprises and institutions applying for entry into the supply chain based on the overall operation status of the agricultural supply chain, and assess the business of each entity in the supply chain. Capacity, performance, etc. are evaluated, and the credit risk of each subject is comprehensively evaluated, thereby creating an efficient and safe ASCF environment.

Construction of agricultural logistics network system

The diversified cooperation between the agricultural industry and the logistics industry is an inevitable trend of innovative agricultural supply chains under the current digital environment, and the formation of a complete logistics network system requires the participation of relevant enterprises, governments and other subjects. First, agricultural enterprises should actively respond to the construction of the logistics network, actively accept the connection of the logistics system, and make reasonable plans for the cultivation of agricultural products according to the existing logistics infrastructure (Hu, 2017). Second, logistics companies have made technological innovations, introduced digital technologies such as the Internet of Things and block chain, and established logistics industry alliances, so that the logistics facilities of various companies in the industry can be explored and shared to the maximum extent and form a wider coverage. The logistics network system with stronger logistics warehousing capacity enables the healthy development of the logistics system under the monitoring of the Internet of Things technology. Third, the government should actively advocate the construction of a diversified logistics network system, and can also introduce relevant policies to encourage the construction of a diversified logistics system, including preferential policies for logistics companies and agricultural enterprises. Since food safety issues have always been the top priority of people's attention, it is also necessary to formulate industry unified technical standards as soon as possible, guide the orderly and healthy development of ASCF, and provide stable and reliable support for the revitalization of rural industries.

Improvement of the technical risk monitoring system

The supply chain financing operation process is complicated and interlocking. The ASCF platform should design a reasonable business process based on the business characteristics of ASCF. By setting up special business departments, formulating special operation guidelines, and establishing a sound internal control management system, we can realize the technical risks that may exist in each link. Effective control (Zhou, 2019). First, strengthen the publicity of the combination of digitalization and ASCF, focus on improving the level of awareness of the participating entities in digital ASCF, and promote the popularization of digital technology in the operation process. Considering that the blockchain technology has great potential to solve the bottleneck problems of low visualization of transaction process, easy data tampering, limited credit object and high monitoring cost (Saber *et al.*, 2019), the application of blockchain technology in order financing, prepayment financing and accounts receivable financing should be expanded (Hofmann, Stewe, & Bosia, 2018). Second, refine the operational guidance of each link and put forward clear operational requirements. In the review stage, a special investigation template is developed, and the staff collects information based on the template to reduce the possibility of the enterprise concealing its true trade background; in the credit granting stage, it is clear that the agreement is signed with the credit main body and its upstream and downstream enterprises, electronic signatures, bill instruments The execution points and requirements of the delivery and execution of business, etc., to reduce the risks caused by operational errors and irregularities; in the post-loan management

stage, the operational procedures and key points of attention should be drawn up for various matters such as fund payment, collateral supervision, and loan recovery. So that staff can be managed according to specifications. Third, establish a special risk management department and special posts, and clarify the division of labor between each post, so that each post can cooperate with each other while supervising each other, and realize the specialized and standardized operation of ASCF.

Improvement of relevant laws and regulations

While ASCF promotes the development of agricultural industry and the strategy of rural revitalization, it will also face the blank area that has not been stipulated by law, resulting in various legal disputes. First of all, the national legislature needs to introduce and improve the corresponding laws and regulations, and clarify the legal definition. For example, relevant chapters have been added to the "E-commerce Law" to make up for the lack of definition of legal concepts such as pledge rights and security rights in supply chain financing, ownership of property rights, and registration systems. Secondly, there are no corresponding laws and regulations on the ASCF platform, and there is a lack of legal binding force. There is also a lack of supervision on the cross-business of financial institutions and logistics companies, which requires the legislative department to draft Laws and regulations, protect the rights of each subject, stipulate the obligations of each subject, clarify the regulatory subject, establish and improve a reasonable and effective regulatory mechanism to meet the development requirements of ASCF. Finally, relevant laws and regulations on protecting information security and personal privacy should also be updated to apply to the general background of the continuous development of digital technology and maintain the normal order of the agricultural supply chain.

CONCLUSION

At present, the rapid development of e-commerce has not only changed the way of life in agricultural and rural areas, but also has a profound impact on the agricultural field in China. The combination of early offline ASCF and e-commerce platforms made the financing process more convenient, faster, safer and more efficient. We propose that the development of ASCF based on the e-commerce platform can not only alleviate the financing difficulties of agricultural enterprises, enhance the resilience of agricultural economic development, but also realize the poverty reduction effect of agricultural enterprises and integrate agricultural supply chain resources in this paper. Based on the e-commerce platform, we analyze the accounts receivable finance mode, inventory finance mode and prepaid account mode in this paper. In addition, in view of the natural risks, credit risks, logistics risks, technical risks and legal risks that may exist in the operation of these financing modes, we have proposed a risk management mechanism ASCF based on the e-commerce platform, which may provide new solutions for agricultural small and medium-sized enterprises and farmers to overcome financing difficulties, so as to promote the development of agriculture and accelerate the process of rural revitalization strategies.

ACKNOWLEDGMENT

This work was financially supported by major projects of innovation fund of Nanjing Institute of Technology 2020: Research on innovation and promotion path of credit agglomeration mode of Jiangsu agricultural supply chain finance under the background of new infrastructure construction (CKJA202004), China; finance development special fund project of applied research fine engineering of social sciences of Jiangsu province 2019: Research on the realization path of "going out" of private enterprises in Jiangsu province with digital supply chain finance precision service under the strategy of "one belt and one way" (19SCB-015), China.

REFERENCES

- [1] Dou Y.Q., Gao X., & Zheng M.X. (2020). Digital supply chain financing and innovation of financing mode for technology enterprises. *Science and Technology Management Research*, 40(8): 112-119. doi: 10.3969/j.issn.1000-7695.2020.8.015 (in Chinese).
- [2] Dou, Y. Q., & Zheng, M. X. (2019). Research on theoretical framework, conditional constraints and governance strategies of B2B supply chain finance. *Journal of Nanjing Institute of Technology (Social Science Edition)*, 19(2), 46-51. doi: 10.13960/j.issn.2096-238 X.2019.02.009
- [3] Guo J., Gu L.Y., & Yang L.C. (2020). Poverty Alleviation of Agricultural Supply Chain Finance in China: Review and Retrospect. *Journal of Beijing Jiaotong University (Social Science Edition)*, 19(01), 106-113. doi: 10.16797/j.cnki.11-5224/c.20200106.010 (in Chinese).
- [4] He G.W., & Liu T. (2018). Rural financial predicament and innovative choice based on rural revitalization perspective. *Academics*, 32(10): 46-55. doi: 10.3969/j.issn.1002-1698.2018.10.005 (in Chinese).
- [5] Heng, M. S. (2001). Implications of e-commerce for banking and finance. In *Towards the E-Society* (pp. 317-327). Springer, Boston, MA. doi: 10.1007/0-306-47009-8_22
- [6] Hofmann, E., Strewe, U. M., & Bosia, N. (2018). Discussion—how does the full potential of blockchain technology in supply chain finance look like? In *Supply Chain Finance and Blockchain Technology* (pp. 77-87). Springer, Cham. doi: 10.1007/978-3-319-62371-9_6
- [7] Hu J.M. (2017). Problems and countermeasures of the development of cold chain logistics of fresh agricultural products in my country. *Reform and Strategy*, 33(5): 82-84. doi: 10.16331/j.cnki.issn1002-736x.2017.05.024 010 (in Chinese).
- [8] Kaplan, S., & Sawhney, M. (2000). E-hubs: the new B2B marketplaces. *Harvard Business Review*, 78(3), 97-97.
- [9] Li, W. J., & Ma, H. W. (2011). Analysis of supply chain financing based on the B2B e-commerce. *Science-Technology and Management*, 13(4), 68-72. doi: 10.16315/j.stm.2011.04.030

- [10] Lin G.Y. (2019). Research on supply chain integration of fresh agricultural products based on "new retail". *Modern Agriculture Research*, 4(9): 139-140. doi: 10.19704/j.cnki.xdnyyj.2019.09.057 (in Chinese).
- [11] Liu G. (2019). Study on the strategy of financial aid for rural revitalization in internet supply chain. *Theoretical Investigation*, (06):118-123. doi: 10.16354/j.cnki.23-1013/d.2019.06.019 010 (in Chinese).
- [12] Liu X.C., & Cheng E.J. (2013). China agricultural industry chain financing mode-typical cases and theoretical implications. *Finance & Trade Economics*, 34(8): 47-57. doi: 10.19795/j.cnki.cn11-1166/f.2013.08.005 (in Chinese).
- [13] Saberi, S., Kouhizadeh, M., Sarkis, J., & Shen, L. (2019). Blockchain technology and its relationships to sustainable supply chain management. *International Journal of Production Research*, 57(7), 2117-2135. doi: 10.1080/00207543.2018.1533261
- [14] Spagnoletti, P., Resca, A., & Lee, G. (2015). A design theory for digital platforms supporting online communities: a multiple case study. *Journal of Information technology*, 30(4), 364-380. doi: 10.1057/jit.2014.37
- [15] Wang S.G. (2019). Current status of agricultural and rural finance and agricultural industry. *Rural Finance Research*, 39 (7): 7-8. doi: 10.16127/j.cnki.issn1003-1812.2019.11.001 (in Chinese).
- [16] Wen F. (2019). Exploring innovative practice of smart supply chain financing. *China Forex*, 27(24): 48-50. doi: 10.13539/j.cnki.11-5475/f.2019.24.016 (in Chinese).
- [17] Wu, L., Yue, X., Jin, A., & Yen, D. C. (2016). Smart supply chain management: A review and implications for future research. *The International Journal of Logistics Management*, 27(2), 395-417. doi: 10.1108/IJLM-02-2014-0035.
- [18] Xu Z.Z., & He Y.S. (2020). Research on the model of agricultural smart supply chain under the strategy of rural revitalization. *Logistics Engineering and Management*, 42(02),32-34. doi: 10.3969/j.issn.1674-4993.2020.02.011 (in Chinese).
- [19] Yang M., & Zheng C.G. (2020). Application of the blockchain to targeted poverty alleviation. *Journal of Yunnan Minzu University (Social Sciences)*, 37(2), 82-87. doi: 10.13727/j.cnki.53-1191/c.20200313.019 (in Chinese).
- [20] Yu W., & Zhang P. (2019). Research on the characteristics of spatial and temporal differentiation and influencing factors of China's agricultural development resilience. *Geography and Geo-information Science*, 35(1), 102-108. doi: 10.3969/j.issn. 1672-0504.2019.01.016 (in Chinese).
- [21] Zheng Q.M., Dou Y.Q., Wu Y.S. & Shi Y.D. (2019). Research on operation mode and risk prevention of B2B supply chain finance. In *Proceedings of The 19th International Conference on Electronic Business* (pp. 373-380). ICEB, Newcastle upon Tyne, UK, December 8-12
- [22] Zhou R.Y. (2019). Research on the Risk Management Mode and Innovation of Internet Supply Chain Financing--Taking JD Finance as an Example. Zhejiang University, Hangzhou, Zhejiang. doi: 10.27461/d.cnki.gzjdx.2019.000325 (in Chinese).

Research on the Bionic Product Design of Smart Home Robots for the Urban Youth

(Full Paper)

Xin Liu*, Institute of Art and Design, Nanjing Institute of Technology, Nanjing, China,
181008386@qq.com

Wen Zhang, Institute of Art and Design, Nanjing Institute of Technology, Nanjing, China,
yiyi97971111@163.com

Qiulu Zhou, Nanjing Forestry University, Nanjing, China, 1273352647@qq.com

ABSTRACT

With the rapid development of science and technology, smart home robots have entered our lives. By analyzing the related concepts of smart home robots and bionic design, and studying the characteristics of the youth group, this paper puts forward the bionic design of smart home robots for the youth, and finally puts this design idea into practice from the aspects of product effect, product size and APP design etc. In this way, it is expected to provide ideas and methods for the design of smart home robots.

Keywords: Youth, intelligence, robot, bionics, product design.

*Corresponding author

ANALYSIS OF RELATED CONCEPTS

Smart Home Robot

Smart home robot is one kind of smart mobile robot, a new generation of robots in response to the development of science and technology. Smart home robot boasts strong ability to self-regulate and adapt to the home environment. Because the robot is equipped with various sensor devices, it can perform the functions of information learning and interaction. (Jin, 2017) Smart home robot is a personal assistant in the smart home, applying artificial intelligence and language interactive processing ability. It can analyze the owner's needs so as to provide the necessary help with no intervention of the owner.

Smart home robot is a combination of the Internet of Things and artificial intelligence, whose functions cover all aspects of home automation, maintenance and control. With them, the users can create smart home according to their wishes. The technological breakthrough in the field of smart home is to strengthen the connection between owners and houses through robotics and the Internet of Things. By understanding the needs of owners and providing customized services, smart homes will achieve a higher level of personalized experience.

Development Status at Home and Abroad

As the country with the most advanced intelligent robot technology, the United States boasts the robots with strong adaptability, stable performance, complex functions, and high accuracy. Meanwhile, such technology has been widely used in industries such as aerospace and automobile industry. Thus, technologies, like sensory bionic and artificial intelligence, have achieved continuous growth in the United States. In Japan, robotics technology has got rapid development with the assistance from various supporting policies, and a series of robotic equipment used in medical, technology and other fields has been developed. Compared with other countries, European countries studied the development and application of intelligent robots even much earlier. Although China is a late starter in intelligent robot technology, it has received strong government support and attracted enterprises to participate in actively in recent years, which has made the robot industry advance considerably. Moreover, intelligent robots have been regarded as the carrier of changes and innovations in the entire manufacturing industry.

Modern intelligent robots are not only widely used in national defense, service, sports and other fields, but also penetrate into every corner of life. However, the global research on smart home robots is still in its infancy. It is estimated that the market penetration rate of our smart home robot industry will gradually increase in the next five years. At present, the research directions of smart home robots are mainly in unmanned systems, bionic robots, technologies caring for the disabled, intelligent prostheses, etc. In the future, smart home robots such as escort robots, monitoring robots, learning robots and pet robots will quickly integrate into users' lives (Li & Li, 2018). In order to make high-quality services of intelligent robots provided in all aspects of human activities, companies and designers hope to build intelligent home service robots into an industry larger than the pet market to meet people's home life needs.

Bionic Design

The subject of bionics was born in the early 1960s, when bionics was defined as "the science of imitating biology." In the process of continuous evolution and reproduction, nearly 1.4 million life forms appeared. Specifically speaking, the bionic design includes the imitation of form, function, structure, color etc. (Zhang, 2009). It combines the aesthetics and use functions

of modern products with the structural modeling of animals and plants in nature, and applies them to the intelligent robot bionic products design, so that intelligent robots can provide much more excellent experience than general product design does in terms of sense, shape and structure. Thus, bionics and bionic design have made outstanding contributions to the research of home intelligent robots.

Bionic design is a new interdisciplinary subject developed on the basis of bionics and design. In the way of observing and studying the characteristics of animals and plants in nature, design inspiration is obtained, which then is reasonably applied to design works after analyzing and processing (Quan *et al.*, 2019). When using bionics to deal with problems in industrial design, bionics is only an enlightenment, where skeuomorph is the key. However, it is not a simple imitation, but the emphasis of the subjective initiative of designers to highlight the characteristics of visualization through analogy (Xu, 2019).

Generally speaking, bionic design is to use the relevant knowledge of bionics to design industrial products. Its methods include imitating biological form, biological structure, biological function, biological color, biological texture etc. Among them, the imitation of biological form can be divided into the concrete one and the abstract one. The bionic form is divided into concrete and abstract. The concrete one is an obvious biological prototype, which is more common in children or scene products. The image bionic product is in pursuit of similarity in spirit, featuring suggestive and associative, such as Jacobson's swan chair etc. Bionics of structure and function is to get inspiration from organism's body structure and then realize the similar functional structure, such as honeycomb sandwich structure board designed by imitating honeycomb. Texture bionics is to make the products get the required touch and look through the design of materials such as the shark skin design of swimwear greatly, which greatly improves the swimming speed (Gao *et al.*, 2019).

The current development of bionic robot is in the fourth stage. In the original exploration period, it imitates the prototype of biology, which helped give birth to the first generation of something like human-driven aircraft. In the middle and late 20th century, it entered the period of macro bionic shape and motion bionic when designers used electro-mechanical systems to design robots, making them able to jump, run, fly and do other actions. After entering the 21st century, more complex integration took place, such as the integration of traditional structures and bionic materials, and the combination of electro-mechanical systems and biological properties began to be used to develop a series of bionic robot devices applied in various fields. At present, we are moving towards the fourth stage of robotic human life system, which means the combination of structure and biological performance.

Analysis of Robot Sensory Bionic Technology

As the cutting-edge technology of robots, the sensory bionic technology of robots has been continuously developed. As human being is the only creature defined as the advanced animal, the higher the degree of robot anthropomorphism is, the more difficult such technology will be. In order to realize sensory bionics, the smart home robot is equipped with a variety of external sensors so as to perform sensory functions such as listening, seeing, touching smelling and so on. All of them constitute an important perception system for robots to communicate freely with the users.

Through research and analysis, it is concluded that in order to achieve a high degree of robot bionics, product design is mainly based on the following important sensory elements for its bionic analysis. Among them, the information obtained by vision accounts for 4/5 of all the information that humans can perceive, so we use cameras to shoot and record foreign objects, and analyze the obtained images in the robot system to complete their identification, recognition, and positioning, so as to perform the functions of remote home monitoring, patrol and GPS positioning. Hearing is used to analyze the user's language information and perform human identification. To obtain sound information, we use a microphone and the sound card to transmit it into the equipment system. The user communicates with the robot in natural language, allowing the robot to find the voice target in the certain environment and realize intelligent voice interaction with the user, so as to complete the corresponding task. In addition, the integrated voice interaction system of the robot is integrated into the design of the home intelligent robot companion, by which the user can control and monitor the home environment through voice commands (Shen, 2017).

Although the robot olfactory function is not yet mature, it has also achieved some development. For example, a service robot "RI-MAN", developed by Japanese scientists for the accompaniment of the elderly, uses the artificial olfactory device, "electronic nose", in the gas sensor. It can distinguish eight different odors. In this way, smart home robots can use the olfactory function to detect the content of harmful gases in the air. Once it reaches a certain level, it can be sent to the mobile phone of the user and the emergency contact, providing a safety guarantee for people's lives.

At present, the artificial taste is realized mostly by the application of electronic tongue devices based on taste sensors. If you want to make the robots react to the taste substances, you should use similar bio-taste sensing materials as sensitive membranes, and make them interact with the taste substances, changing the potential on both sides of the membrane, which makes multiple taste substances interact with each other and produce the same way of biological taste feeling, so as to realize the function of artificial taste. With this technology the robots can be equipped with high bionicity so as to have its sense of reality improved (Gao *et al.*, 2019). However, the product's perceptual personification also affects the degree of user satisfaction. Female voices are better than males in voice emotional interaction. Therefore, the voice of smart home robots is prone to be female timbre. At the same time, there is a certain degree of danger. For example, once the robot's anthropomorphization level is too high, it will

show the uncanny valley phenomenon, which will bring the opposite feeling to the user. Thus, as the main body of the service, the user occupies a dominant position in the dialogue. We need to control the degree when researching (Liu *et al.*, 2019).

Robot Appearance Bionic

Bionic robot product design integrates various biological experiences, perceptions and social abilities by imitating the appearance and movement functions of creatures. First of all, in terms of its appearance, a high-level bionic intelligent robot can make users feel intimacy, reducing the psychological and physical barriers between humans and robots, and enhancing interaction and social skills. Secondly, products designed for specific groups of people should follow three principles. The first is experiential design with strong emotional output, whose most critical part is the sensory experience, so that users can enjoy the interactive experience brought by cognition, hearing and vision (Liao *et al.*, 2019). The second is to meet the use principles of emotional design, combining the specific people's psychological and emotional needs with their life use needs, making humans and robots coordinate with each other. In this way, a size and functional structure which conforms to common sense can be designed (Chen & Xue, 2019). The third is the popular principle of appearance design, which requires the characteristics of the times to be shown and the public's aesthetics to be satisfied.

Thus, the design of bionic products of smart home robots requires novel appearances and diverse structures. Meanwhile, bio-like design in the robot skin, senses, expressions and other parts is needed to achieve emotional upgrades. What's more, in order to follow the demand principle, designers need to conduct user research to analyze their needs, making the products more intuitively presented. In addition, designers should have a keen insight into the changes of the specific group's life attitudes and lifestyles so as to discover potential social needs in the future: a. Use interactive humanization design b. Use simulation scenarios for naturalization c. Use information processing for agility (Zhao, 2018).

LIFESTYLE AND CHARACTERISTICS OF THE URBAN YOUTH

Young people are the most energetic people, full of dreams. They are both builders and consumers. They grasp the right to decide the future lifestyle, and the future of the world belongs to the younger generation. China has a huge youth population. By the end of 2016, there were 433 million people in total, among which urban young people reached 268.91 million. With the process of population aging and urbanization, the number of young people is shrinking, while the urban young people group is expanding (Deng *et al.*, 2019).

Lifestyle of the Urban Youth

The life of urban youth can be summarized from the aspects of life service, social style and personal habits and so on. First, in terms of life services, with the development of new things such as the Internet and the express industry, people can meet their daily needs through various food delivery platforms and e-commerce software without leaving their homes. Second, in terms of social networking, the popularization of the Internet reduces the chances for people to communicate face-to-face, and young people's home life is more of online communication through dating software and self-media platforms. Third, in terms of personal habits, young people are used to having independent private space and prefer self and personalized life (Gao, 2019). The home activities of the youth can be mainly divided into four main stages: tidying up, replenishing energy, spiritually communicating and washing and rest. Among them, playing with pets and socializing on the Internet are the emotional high points, while taking care of pets, waiting for takeaway and some other stages tend to be the emotional low points (Wang, 2018). According to the analysis of the home activities of youth groups, what the youth need is to increase the opportunities for face-to-face communication on the basis of retaining independent private space and personalized lifestyle.

Life Characteristics of the Urban Youth

The contemporary urban youth prefer to maintain their own ideas and protect their private space. They often gather in circles based on their interests and preferences, create their own discourse systems and become the starters of many online popular cultures. The lives of young people are characterized by independent living space and extensive network communication. The life characteristics of urban youth groups mainly include: First, their lack of face-to-face communication. The urban youth groups' home life features living alone, lacking language communication. Second, their preference for independent private space. The new generation of youth generally pay more attention to privacy, so they hope to have independent private space. Third, their higher degree of acceptance of new things such as the Internet. Meanwhile, they prefer a personalized lifestyle.

DESIGN IDEAS OF THE BIONIC PRODUCTS OF SMART HOME ROBOTS FOR THE URBAN YOUTH

Design Research

According to the analysis of the urban youth's home life, their emotional high points are shown when playing the pets and socializing online. Therefore, the combination of pets and social interaction can better enhance the emotional interaction experience at home. Young people pay more attention to the intelligent, automatic, and emotional products, which not only meet their emotional interactive experience, but also reduce unnecessary troubles in the use process. And Smart home robots can provide more accurate choices for such users. In addition, designers are more proactive in the design of robot's function, structure, and appearance. Young users have high demands in aspects of safety, companionship and care, which means that emotional robot companions will enjoy great popularity.

Sketch design

Through design research, designers have certain knowledge and ideas about the product. They carry out the idea through hand-drawing sketches, designing the appearance and internal structure of the product. Home robots are products featured with daily companionship, which shows that all involved elements are extracted from all things in nature, and the bionic objects are processed in terms of form, structure, and color and so on.

Ideas at this stage are often instant, lacking precise size information and geometric information. Based on the designer's idea, they record in the form of sketching, draw various forms or mark and record the design information so as to determine three to four directions, and then the designers implement brainstorm and in-depth discussion, as shown in Figure 1.

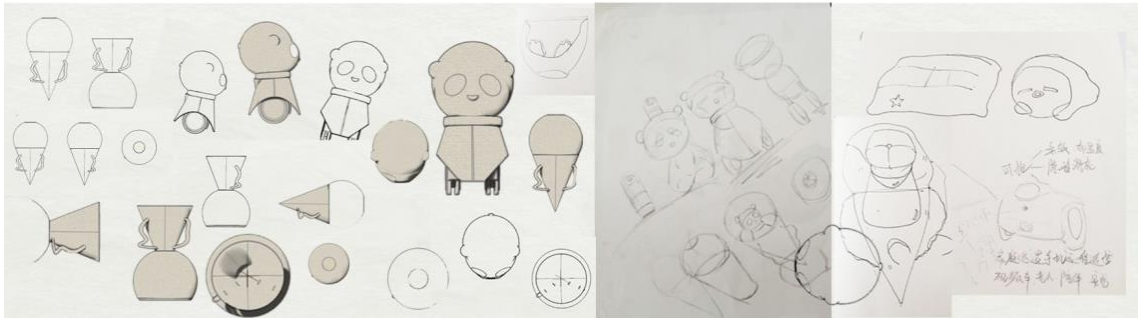

Source: This study.

Figure 1: Design sketch

Modeling and designing drawings

Based on the conclusions of the brainstorming meetings, the designers use modeling software to create a three-dimensional model to generate a multi-angle effect diagram to show the final effect of the product. Three-dimensional model is a process of describing the product's shape and structure, which can reflect the intuitiveness of the design and the authenticity of the product. By observing and adjusting the shape of products from multiple angles, conceiving the structure of products more intuitively, expressing the conception of products more accurately, the quality of product design can be improved and communication with customers can be facilitated.

Design Proposal Report

By providing different product design schemes, explaining the shape, color matching, process and application of the product, the designer can form a design scheme report based on the design scheme and explains it to the company or customers.

THE PRACTICE OF BIONIC PRODUCT DESIGN OF SMART HOME ROBOTS FOR THE URBAN YOUTH

Extract Bionic Prototype

Home robots are products featured with daily companionship, which shows that all involved elements are extracted from all things in nature, and the bionic objects are processed in terms of form, structure, and color and so on. Elements such as cute pets, animation, sports and desserts, preferred by the youth today can be the source of design inspiration. The contemporary youth prefer cute pets, which means the pets featured with "cute" in that they can relieve people's mental stress and bring happiness. Giant panda, cute and innocent, is a unique rare animal in China. Therefore, its classic black rim of the eye and big head are used as the source of animal elements in product design, as shown in Figure 2a. Most young people love cartoons. Whether it is online drama chasing, offline collection or role playing, it is the practical action of the youth to show love. Nezha is a well-known character in China. With generations of Chinese growing up, his lively, cute, brave and kind-hearted image is deeply rooted in the hearts of the people. Therefore, Nezha's round bun image in cartoons is used as a design element, as shown in Figure 2b.

Balance scooter is a popular transportation tool for young people for its simple, portable, stylish features, and it has become a cool toy for young people. Therefore, the power wheel of balance scooter is used as a design element, as shown in Figure 2c.

Ice cream is a very attractive and delicious frozen dairy product. In China, it has been transformed from a seasonal heat-relief consumer product to a four-season snack food. It is deeply loved by young people. Therefore, the shape and color of ice cream are used as design elements, as shown in Figure 2d.



Source: This study.

Figure 2: Source of design inspiration

Redesign of Bionic Prototype

The redesign of the bionic prototype is to integrate various bionic elements as a whole. By drawing on the dark circles and big heads of giant pandas and combining the cartoon Nezha's bun shape, the head shape of the product is designed as the round one with round ears and dark circles, so as to make the whole head shape naive. By drawing on the shape of the power wheel of the balance car, the designer designs the flexible legs and feet in the shape of wheels for the product. Drawing on the ice cream shape, the designer presents the whole product as a straight shape with a slightly narrow lower body.

Design Presentation

The product is named as "Zhi Ling", with the homophonic "command" in Chinese, which means the companion robot that satisfies the user's instructions. "Zhi" stands for intelligence, and "Ling" is the robot nickname, Xiaoling, which also has the pronunciation of dear "darling" in English, giving people a sense of intimacy. The Zhiling series robot products can be set to two kinds of personality, one being "the adventurer who rides the wind and waves", the other being "a well-behaved little adult", who can continuously "grow" according to the user's personality.

The robot is also equipped with a computing chip with the same speed as a car, which can make it conduct indoor maps so as to automatically recognize obstacles, and walk freely indoors. The robot has a removable magnet camera. According to the patrol monitoring, it can shoot a certain space image screen to realize the function of automatically appearing when the owner goes home or goes out. The robot brain system is equipped with four microphones, a hemisphere camera, a temperature camera and a depth camera, and the whole body has various sensors such as air pressure, distance measurement and so on. The face and eyes of "Xiaoling" use a mix of metal material and transparent glass mirror material, as well as a plush material head and cloth cloak, which makes users involuntarily show affection. At the same time, the robots Aling and the Zhiling APP are connected to the smart home system, by which the owner can easily control the use of household appliances.

Function and shape design

The main body of the robot is composed of a robot brain, a head camera, a facial expression display screen, and a sensor power wheel. The robot brain is equipped with sensing tentacles, a 360 degrees' dome camera, microphone, thermal camera and other equipment. When the button behind the robot brain is pressed, it is turned on. A removable magnetic camera is used to connect to the robot head. The external information can be photographed so as to make outside objects recorded. After analysis in the robot system, it can blink, wink and roll eyes through the facial expression display screen, and give feedback according to the user's behavior, as shown in Figure 3.



Source: This study.

Figure 3: Product color scheme.

The size of the smart home robot is 44cm high, 26cm wide. The head size is 14cm high, and 20cm wide. The total height with the hat is 20cm and the width is 26cm. The hat is slightly larger and looks more cute. With the cape the length is 16cm and the width is 18cm. The wheels are 12cm high and 6cm wide. The ice cream backpack is 80cm tall and 40cm wide. The cylinder is 45cm long, and the diameter of the cross-section is 34cm. The diameter of the spherical cover is 40cm, and the top contains ventilating holes, as shown in Figure 4.

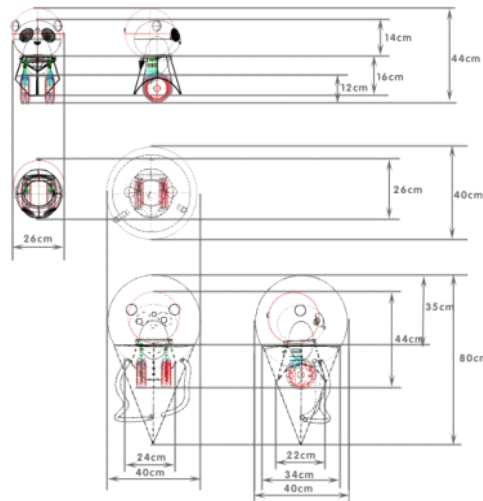

Source: This study.

Figure 4: Product size diagram.

Color matching design

In order to make the product design diverse and choices personalized, four different styles have been derived from color matching to meet the needs of different people: The mature business style is black with gray texture, showing a mature and stable style, as shown in Figure 5a. The casual holiday style is tan with bright yellow, conveying a sunny and free life attitude, as shown in Figure 5b. The intellectual style is mainly milky white and supplemented by the haze blue, showing a sense of fashion maturity, as shown in Figure 5c. The exquisite girly style is orange-pink with milk tea to highlight the delicate and soft feeling, as shown in Figure 5d.



Source: This study.
Figure 5: Product color scheme.

APP design

The APP is designed to enhance the interactive experience based on the design of smart home robot bionic products. Figure 6 is the mobile phone APP interface design derived from the robot device. When you open the homepage, you will see "Xiao Ling"'s home, including functional icons such as air detection, emergency contact, Xiao Ling's moments, etc, which can be used to control the behavior and language of Xiaoling at the terminal.

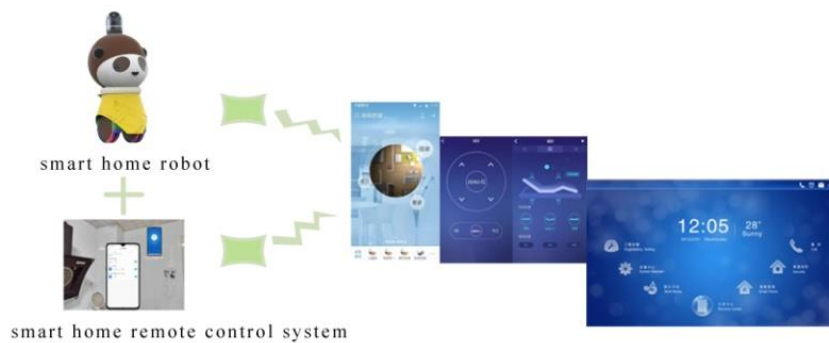

Source: This study.
Figure 6: Smart APP interface design

CONCLUSION

Product design needs to follow the process of social development, guiding and meeting the needs of consumers. With the development science and technology, smart home robots begin to enter people's lives. As a kind of smart home products, it can meet people's needs of companionship and communication. In this paper, we design smart home robots with young people as the target group. The bionic design ideas are adopted to design smart home robots for the youth from the aspects of product effect, product size and APP design and so on. It is expected that through the research in this paper, new cognition and ideas concerning the smart home product design can be generated.

ACKNOWLEDGMENT

This work is sponsored by the Scientific Research Foundation for the High-level Personnel of Nanjing Institute of Technology (No. YKJ201991), and the Open Research Fund of NJIT Cultural and Artistic Creativity Design Institute (No.CACD202014).

REFERENCES

- [1] Chen, X., & Xue, L. (2019). Research on interactive design of aging smart home products based on QFD/TRIZ. *Packaging Engineering*, (20), 74-80. <https://kns.cnki.net/kcms/detail/detail.aspx?dbcode=CJFD&dbname=CJFDLAST2019&filename=BZGC201920014&v=4W5apLBdGckf3Rs3rpPVVzHSJuW%25mmd2FXGJz4w7p7a98%25mmd2B6%25mmd2FrFMv0nbd916kcCtCxfJI>
- [2] Deng, X. Q., Li, J., & Xu, H. F. (2018). Statistical report on China's youth population and development. *Journal of Guangdong Youth Vocational College*, (04), 5-13. <https://kns.cnki.net/kcms/detail/detail.aspx?dbcode=CJFD&dbname=CJFDLAST2019&filename=GDQI201804002&v=oJAQoXpNrkkdJLkHfEstOO5%25mmd2B7NJGzm qfVRAhFnRzAyvmZ26M5bY8aEa%25mmd2FdqMmOihF>
- [3] Gao, D. W. (2019). Analysis of the living conditions and influencing factors of urban youth living alone in China. *Labor Security World*, (30), 80-81. doi:10.3969/j.issn.1007-7243.2019.30.061.
- [4] Gao, Y., Ma, D. M., & Qian, H. (2018). Research on bionic product design process. *Industrial Design*, 8, 40-41. doi:10.3969/j.issn.1672-7053.2018.08.009
- [5] Jin, L. (2017). The present situation and development trend of intelligent robot. *Industrial Design*, (01), 163. <http://d.wanfangdata.com.cn/periodical/ChlQZXJpb2RpY2F2sQ0hJTmV3UzIwMjAxMjI4Eg1neXNqMjAxNzAxMDgyG ggyOWJxeGZxdg%3D%3D>
- [6] Li, M., & Li, J. (2018). Research on the design of pet companion robot based on pet psychology. *Popular Literature*, (24), 82-83. doi: 10.3969/j.issn.1007-5828.2018.24.055
- [7] Liao, Q. L., Wang, M., & Feng, Z. (2019). Voice interaction design of smart home products based on emotional interaction. *Packaging Engineering*, (16), 37-43. <https://kns.cnki.net/kcms/detail/detail.aspx?dbcode=CJFD&dbname=CJFDLAST2019&filename=BZGC201916010&v=4W5apLBdGckVBoVuabfqgynUPbdsoZ5EtSC5fDj7z0K %25mmd2FneGKAytGFHYZVSY8Zh4w>
- [8] Liu, W., Shi, Y., Dong, Y. F., Yu, F., & Sun, J. G. (2019). Research on functional innovation in bionic design. *Packaging Engineering*, (14), 186-191. <https://kns.cnki.net/kcms/detail/detail.aspx?dbcode=CJFD&dbname=CJFDLAST2019&filename=BZGC201914034&v=4W5apLBdGcm5gUqKXKQLiWr%25mmd2FikL8gMobQJGmM0 yzsrOWUgIlxktsfBbY%25mmd2F7e2Y8D>
- [9] Quan, W., Zhang, J. H., Zhai, T. Y., Tong, H. X., & Ren, X. Y. (2019). On the bionic design techniques in the design of children's toys. *Drama House*, (36), 119-120. <https://kns.cnki.net/kcms/detail/detail.aspx?dbcode=CJFD&dbname=CJFDLAST2020&filename=XJZT201936069&v=r1qMIiYDEohQhJ5PASbltOJAH%25mmd2F9IFGIWUF3 3HqxPCpB16aaclyIKMDm2g7DyiLuD>
- [10] Shen, L.L. (2017). Intelligent home robot system based on Kinect vision recognition. *Modular Machine Tool and Automated Processing Technology*, (12), 78-80,84. <https://kns.cnki.net/kcms/detail/detail.aspx?dbcode=CJFD&dbname=CJFDLAST2018&filename=ZHJC201712019&v=n0GpPHcFt%25mmd2FSGK8t6LjOBu%25mmd2Bd L%25mmd2BcVDmD4lCux0PGrnybFBO2amTHmZXGP1R0kHdYHI>
- [11] Wang, Y. Y. (2018). Design and research of household articles based on emotional compensation of alone youth. National Dong Hwa University, 12-15. <https://kns.cnki.net/kcms/detail/detail.aspx?dbcode=CMFD&dbname=CMFD201901&filename=1018832647.nh&v=Fgh1w1YZbOhh%25mmd2BHyCGTFzmDZzqbzrHzH 4BBYrlNDXYg3EhOeQP2cAipztOcQkcQy0>
- [12] Xu, Q. X. (2019). Analysis of the bionic design in industrial products. *Industrial Design*, (07), 66-67. doi:10.3969/j.issn.1672-7053.2019.07.033
- [13] Zhang, X. J. (2009). The localization strategy and experimental research of robot taste source based on olfactory information. Hebei University of Technology, 59-70. <https://kns.cnki.net/kcms/detail/detail.aspx?dbcode=CDFD&dbname=CDFD0911&filename=2009148063.nh&v=TntAtVxUL%25mmd2F%25mmd2FQqDPU9agSSLIpelS mzDOOVguT4vR0FvC9cbTXozEtSpFj4w886v7a>
- [14] Zhao, L. Y. (2018). Application of interaction design in industrial product design —— Review on the basis of product interaction design. *News and Writing*, (04). doi:10.3969/j.issn.1002-2295.2018.04.039.

Research on the Operation of Changzhou Distribution Center of Huitong Express in the Peak Period of Online Shopping

(Full Paper)

Fujian Ge, Nanjing Vocational College of Information Technology, Nanjing, China, gefj@njcit.cn

Li Yao*, Nanjing Institute of Technology, Nanjing, China, yaoli@njit.edu.cn

Xing Gu, Nanjing Institute of Technology, Nanjing, China, guxing@njit.edu.cn

ABSTRACT

With the rapid development of network technology and the improvement of payment tools, the advantages of online shopping have become increasingly prominent, and various online shopping festivals have rapidly emerged. During the peak period of online shopping and the peak season of express delivery business, the market needs don't often be met, and problems such as warehouse explosions, express delivery delays, and false receipts often occur. As an important transfer link of express logistics, Distribution Centers will affect the entire express logistics process once operational problems occur. This topic takes Huitong Express Changzhou Distribution Center as an example. By analyzing the current operating conditions of various departments of Huitong Express Changzhou Distribution Center and the problems that arise during the peak period of online shopping (taking "Double 11" as an example), we will further explore more efficient to achieve the maximum possible profit by reducing costs in order to achieve the maximum possible profit.

Keywords: Online shopping peak; double 11; Huitong Express; Changzhou Distribution Center; efficient operation

*Corresponding author

INTRODUCTION

With the rapid development of network technology and the continuous improvement of electronic payment tools (Alipay, Internet banking, etc.), all of these make online shopping more convenient and secure, and the advantages of online shopping are increasingly prominent. Therefore, the competition between e-commerce is becoming increasingly fierce, and the promotion activities are more and more frequent.

Take "Double 11" as an example. Beginning in 2009, Taobao began to launch "Double 11" promotional activities, with sales of nearly 100 million yuan that day. In the next few years of "Double 11", Taobao and Tmall's transaction volume began to grow wildly: in 2010, the transaction volume was 936 million yuan, in 2011 it was 5.2 billion yuan, and in 2012 it was approximately 19.1 billion. The single-day sales reached 35.019 billion yuan, and the day's transaction volume in 2014 was 57.1 billion. In 2018, "Double 11" day transaction volume reached 210 billion yuan, and in 2019, the day's transaction volume was 268.4 billion yuan. According to Cainiao Network's statistics, the logistics orders generated by Tmall in 19 years exceeded 1.292 billion.

According to statistics, "double 11" period, express industry of the processing volume of 230% of daily volume, it can be seen that express logistics plays an important role in the development of e-commerce. However, up to now, the development of domestic express industry is far behind the development of e-commerce. Especially in the peak period of online shopping, express delivery service cannot meet the market demand. The express Distribution Center is a logistics transfer center integrating processing, goods handling, and delivery functions, and has the functions of storage, sorting, distribution, and connection (Wang, & He, 2007). The problems in the operation of the Distribution Center include: damaged parts, false sign in, overstocking of express goods on the conveyor belt during peak period, and large number of returned parcels. These are very important and common in the express delivery enterprises. Therefore, how to make the Distribution Center still operate normally and efficiently in the peak state of online shopping, and directly determine the logistics efficiency of express, we need to summarize our experience in practice. This paper takes Huitong Express Changzhou Distribution Center as an example, analyzes the problems and causes of these problems in the current operation of Changzhou Distribution Center during the peak period of online shopping. The paper puts forward suggestions on improving the service quality and improving the operation efficiency of the Distribution Center by using theory, so as to make the operation more reasonable and efficient.

ANALYSIS OF THE OPERATIONS

Brief introduction of Changzhou Distribution Center of Huitong Express

Established in 2003, Huitong Express is a large private express company that took the lead in using information technology in China. Changzhou Distribution Center is a three-level branch company subordinate to Huitong Express Company. The higher-level departments include Shanghai Huitong Express Headquarters and Huitong Jiangsu Branch Management Center. At present, Huitong Express Changzhou Distribution Center is in the second phase of GLP Logistics Park, Huanghe West Road, Xinbei District, Changzhou City. It is geographically located at the northern urban-rural border of Changzhou City, near Changzhou

Luoxi Hub, and away from S39 Jiangsu Jiangyi Expressway and G42 Shanghai It is about 3 minutes' drive from the intersection of Chengdu Expressway; about 25 minutes' drive from Changzhou Benniu Airport. It is about a 20-minute drive from downtown Changzhou, and it can directly lead from the outer ring to Wujin District in the south of the city. Overall, the location is very advantageous.

Current status of Huitong Express Changzhou Distribution Center

Changzhou Distribution Center is currently divided into the following departments:

(1) Network department: including network director, network assistant and BEX direct point department. Network department is also known as "quality control department", as its name implies, is the Department controlling quality. The network department is not only subordinate to Changzhou Distribution Center, but also under the management of Jiangsu provincial network department, the superior department of the network department. The main function is to control the dispatch speed and quality of each site (currently the stations supervised by Changzhou Distribution Center include 35 stations in Changzhou, Danyang stations, Changshu stations, and a total of 80), and timely feedback to the superior departments on the situation of the Distribution Center and subordinate management sites at the same level. Huitong Express is the distribution mode of the combination of the management of the outlets (stations) and "BEX direct business point Department". "BEX direct business model" is a new distribution mode adopted since Huitong Express was acquired by Baishi Group. It refers to the dispatch site of express company is directly managed by the Distribution Center, and the dispatcher is directly recruited by the company. This can have certain constraint effect on the distribution site and small members, which is convenient for data statistics and management, and makes the company more standardized.

(2) Customer service department: also known as LCS (logistics customer service) department in Huitong Express Company. It is mainly responsible for receiving the customer consulting telephone, complaint telephone, etc., and handling the complaint and problem parts of the CRM system of Huitong Express delivery system, helping the customer solve the problems, the handling of the problem parts and the headless parts. Customer service department is one of the few departments in Huitong Express Company that directly faces customers. Therefore, it plays an important role in the cooperation between the Distribution Center and customers and improving the operation efficiency.

(3) Allocation office: the most important operation Department of the Distribution Center. The allocation site covers the largest area and the most operations to be processed. Mainly responsible for the scanning, sorting, city transfer and distribution, remote transfer, problem handling and other work. Huitong Express Changzhou Distribution Center has the largest number of staff, and sorting is usually started at night.

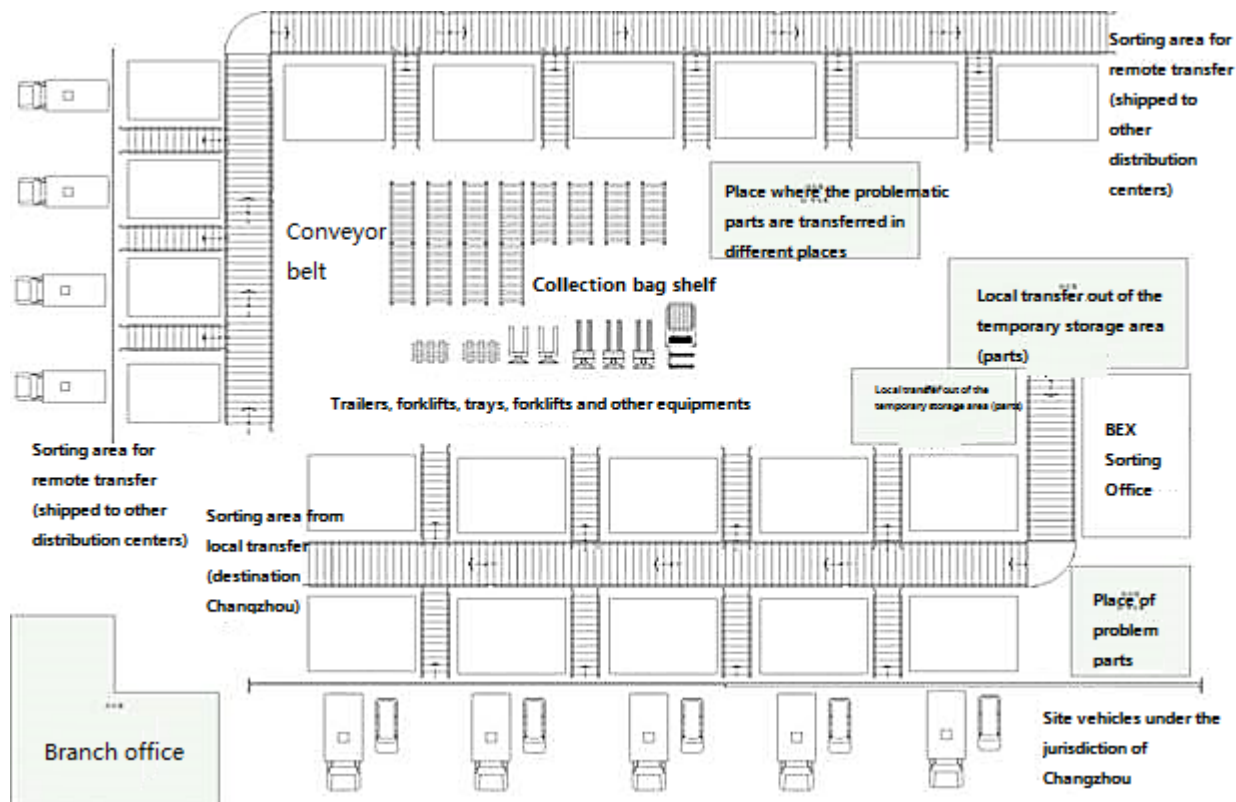

Source: This study.

Figure 1: distribution of Distribution Office of Changzhou Distribution Center of Huitong Express

(4) Administrative department: mainly responsible for staff management and logistics of the company, including city manager, personnel supervisor, financial department, and other personnel.

At present, the transfer belt, forklift, hand-held frame trailer, pallet and other infrastructure equipment are used in the Distribution Center of Changzhou. In sorting operation, manual labor is still used. The distribution office layout is shown in Figure 1.

Daily work of Changzhou Distribution Center

The Distribution Center completes daily work based on existing departments and hardware facilities and equipment. The main process is as follows:

(1) Arrival flow (as shown in Figure 2): the dispatch center of Changzhou receives the goods, and the express arrives at the allocation site for unloading, scans the barcode of the number on the express, and automatically uploads the express to the system; sorting is carried out according to the destination of the express (the corresponding number of the online store will be available on the express): the express sent to the other place, scans, loads, and transfers to the next Distribution Center; it is sent to the same city. The express mail of the company shall be stacked in the transfer out area of the same city, and transported by the operator to the stations under the jurisdiction of each Changzhou Distribution Center through the transmission conveyor belt. The site personnel and site personnel shall scan and load them to their respective stations.

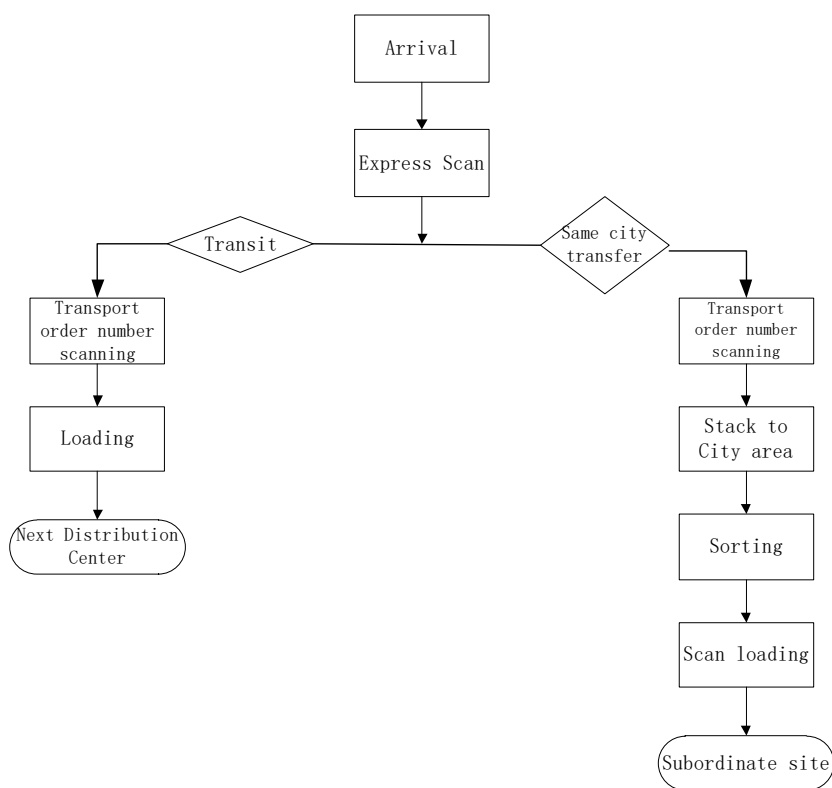

Source: This study.

Figure 2: express to piece flow

(2) Delivery flow (as shown in Figure 3): The parcels are collected from each station and shipped to the Changzhou Distribution Center. The operator sorts them to the corresponding venues according to the numbers on the waybill, scans them, and loads them at night and transfers them out.

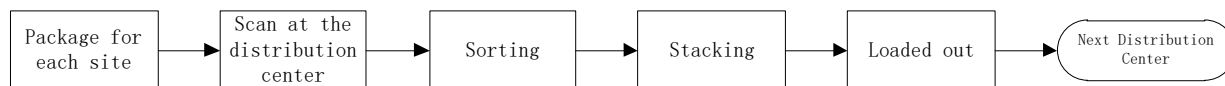

Source: This study.

Figure 3: express delivery process

Whether it is arrival or delivery transfer, the network department shall summarize and feedback daily data of each site during the process, mainly including dispatch quantity, arrival quantity, quantity of goods received, sign in rate and small piece package quantity. If the site is abnormal, it is necessary to deal with the exception. Customer service department handles customer phone,

network complaints and inspection issues in Changzhou District throughout the process, and includes the handling of problem parts.

Analysis of the operation status of Changzhou Distribution Center of Huitong Express in the peak period of online shopping ("Double 11" situation of Changzhou Distribution Center of Huitong Express in 2019)

Table 1: Forecast and actual difference analysis of import and export volume of Huitong Express Changzhou during the period of the double eleven in 2019

date	Predicted quantity	Actual output	Deviation (plus or minus 100%)	Forecast dispatch quantity	Actual dispatch quantity	Deviation (plus or minus 100%)
11-11	80000	89555	11.94%	60000	38188	-36.35%
11-12	130000	153337	17.95%	60000	41534	-30.78%
11-13	100000	100757	0.76%	70000	48214	-31.12%
11-14	70000	66352	-5.21%	80000	52976	-33.78%
11-15	60000	54365	-9.39%	70000	60743	-13.22%
11-16	50000	48909	-2.18%	70000	65299	-6.72%
11-17	40000	43039	7.6%	60000	55920	-6.8%
11-18	40000	52196	30.49%	60000	59513	-0.81%
11-19	40000	44338	10.85%	50000	64699	29.40%
11-20	40000	36933	-7.67%	50000	64904	29.81%

Note: the quantity of outgoing goods refers to the express delivered to other regions by express delivery center of Changzhou by Huitong Express; the dispatch quantity refers to the number of express sent by Changzhou and sent by Changzhou stations.

From Table 1, the accuracy of the network Department of Changzhou Distribution Center is higher than that of the dispatch volume. Meanwhile, the dispatch volume forecast in the first few days is not accurate and the forecast is too much. Moreover, the peak time of online shopping has been delayed more and more in recent years, which makes it difficult to predict.

Table 2: analysis of the rate of goods collected by Huitong Express in Changzhou during the period of the double eleven in 2019

date	11-11	11-12	11-13	11-14	11-15	11-16	11-17	11-18	11-19	11-20
Rate of goods taken	97.56%	98.1%	98.23%	98.21%	96.12%	95.86%	93.9%	96.52%	97.83%	96.64%

Source: data from network Department of Changzhou Distribution Center of Huitong Express

Table 3: collection of packages in Changzhou of Huitong Express during the period of the double eleven in 2019

date	11-11	11-12	11-13	11-14	11-15	11-16	11-17	11-18	11-19	11-20
Packet rate	64.79%	67.96%	71.38%	71.86%	65.57%	71.67%	56.68%	56.59%	63.59%	84.69%
Error set rate	6.41%	4.85%	7.20%	6.59%	14.76%	6.69%	5.32%	5.82%	7.36%	12.21%

Source: data from network Department of Changzhou Distribution Center of Huitong Express

Note: package collection: refers to the small piece express delivery sent to the same place. When sorting in the Distribution Center, it is packed in a large bag, and the large bag has a label indicating that the small pieces in the big bag have the same code. During transportation, the label code on the large bag is used as the information code of the small piece in the whole bag. After arriving at the destination, the bag is unpacked and sorted.

Table 4: the situation of Huitong Express Changzhou warehouse breaking during the period of the double eleven in 2019

date	11-11	11-12	11-13	11-14	11-15	11-16	11-17	11-18	11-19	11-20
Number of block explosive cases /m ²	0	0	0	300	300	500	600	700	700	700
Number of positions in the block /time	0	0	0	20	20	23	25	34	34	34

Source: data from network Department of Changzhou Distribution Center of Huitong Express

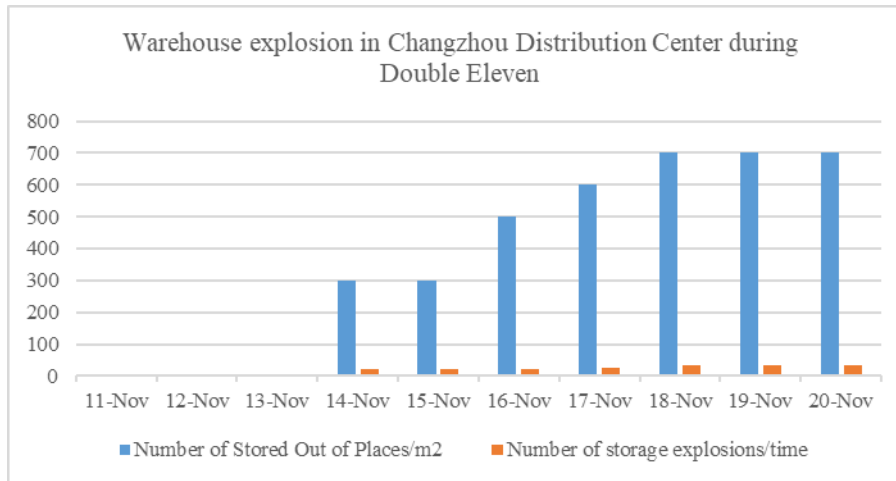

Source: This study.

Figure 4: the situation of Huitong Express Changzhou warehouse breaking during the period of the double eleven in 2019

Note: the card position explosion refers to the statistics of all stations within the jurisdiction of Changzhou Distribution Center.

From Table 2-4 and Figure 4 above, the explosion usually occurs after 14, and it is concentrated after the 18th, that is, the second half of the peak period of online shopping, mainly because of the excessive quantity of dispatched items.

Table 5: distribution of Huitong Express in Changzhou during the period of the double eleven in 2019

date	Quantity of parts to be dispatched	Quantity of signed in time	Signature of on time	Delayed receipt	Backlog	Signed in rate (punctuality and delay)
11-11	38662	37374	96.24%	1245	43	99.89%
11-12	44949	38894	85.4%	5958	97	99.78%
11-13	49258	40338	80.73%	8760	160	99.68%
11-14	57480	46036	77.4%	11248	196	99.66%
11-15	68365	49727	70.01%	18237	401	99.41%
11-16	71027	49413	65.1%	21206	408	99.43%
11-17	62309	37631	55.74%	24256	422	66.71%
11-18	66147	37407	53.49%	28284	456	66.71%
11-19	69687	37937	50.76%	31450	380	66.71%
11-20	60399	34971	55.37%	25232	196	66.71%

Source: data from network Department of Changzhou Distribution Center of Huitong Express

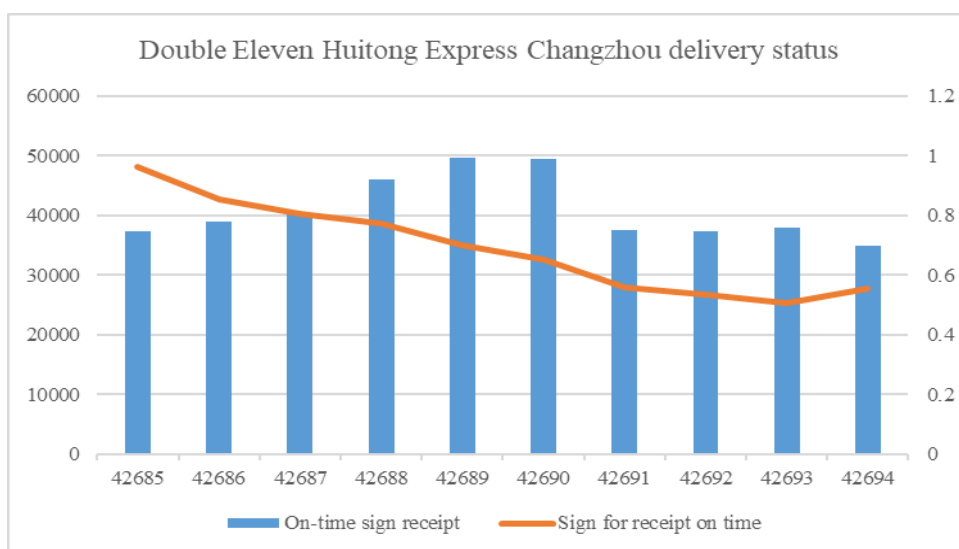

Source: This study

Figure 5: the distribution of Huitong Express in Changzhou during the period of the double eleven in 2019

From Table 5 and Figure 5, the signing in problem mainly started in mid-November, mainly because the foreign parts in the later period entered Changzhou, which led to the explosion. The punctuality-signing rate of last year began to decline since the 17th, and all of them were lower than 60%, which was not good. At the same time, there are also a lot of backlog. Although backlog decreased after 20th, the duration was longer.

Table 6: preparation and use of emergency resources for Changzhou emergency dispatch of Huitong Express during the period of the double eleven in 2019

date	Resource reserve (number of people)	Resource reserve of (site)	Resource reserve (vehicle)	Actual use (number of people)	Actual use of (vehicle)	Actual use (site)
11-11	317	4290	184	317	184	99.89%
11-12	317	4290	184	317	184	99.78%
11-13	317	4290	184	317	184	99.68%
11-14	317	4290	184	317	184	100.66%
11-15	317	4290	184	327	184	100.41%
11-16	317	4290	184	327	184	100.43%
11-17	317	4290	184	327	184	86.71%
11-18	317	4290	184	327	184	76.71%
11-19	317	4290	184	327	184	66.71%
11-20	317	4290	184	327	184	66.71%

Source: data from network Department of Changzhou Distribution Center of Huitong Express

From Table 6, the estimated and actual use of vehicles is relatively accurate and specific in transportation (in Changzhou Distribution Center, it is mainly trunk vehicles and branch vehicles to each station, excluding specific distribution vehicles). There is also no massive congestion and delay. This is a better aspect of doing.

In short, it can be seen from the above tables that before "Double 11", Huitong Express Changzhou Distribution Center made certain forecast preparations, but because the number of online shopping during the peak period of "Double 11" in 2019 exceeded expectations, Therefore, there is a certain difference between actual and estimated, which is mainly reflected in the amount of delivery; on the other hand, the error collection rate on the collection package is higher. At the same time, it can be found from the above table that the logistics cycle this time is relatively long, almost extended by half a month (the above is only 10 days of data, and it lasts until the end of November).

ANALYSIS OF THE PROBLEMS AND CAUSES

Problems and causes of Network Department

In the overall operation of the distribution center, the network department belongs to the department that directly manages the lower-level primary and secondary sites. During the peak period of online shopping, the main tasks include: prediction and

preparation for the pre-peak period of online shopping, including temporary adjustment of personnel, venues, vehicles, equipment, etc. and employment prediction; during the peak period of online shopping, Changzhou is in charge of various data statistics for each site, including: pickup rate, delivery rate, problem rate, etc.; site abnormal situation handling, such as: warehouse explosion, lack of staff; late online shopping peak period, various data statistical feedback, etc.

At present, during the peak period of online shopping, the problems and causes in the operation of network department are as follows:

(1) Poor communication with primary and secondary sites. Since the Changzhou Distribution Center has a large number of sites under its jurisdiction and a wide range, in addition to the nearby Changzhou city and suburb sites, it also directly manages more than 80 first-level sites in Liyang, Jintan, Danyang and Changshu. There are several second-level sites at the lower level; on the other hand, most site managers are not highly educated, generally technical secondary school or college, and do not have professional logistics knowledge. Therefore, if you want to maintain unblocked contact with each site, it is a relatively large amount of work but also a certain degree of difficulty.

(2) Communication with superior is not timely. Besides being managed by the city manager and supervisor of the Distribution Center, the network department is also under the jurisdiction of Jiangsu provincial network department. Therefore, there are many management situations sometimes. At the same time, it also leads to a lot of data that the network department needs to statistics and feedback, and the workload is large. Especially in the peak of online shopping, we often pay attention to the data late into the night. In addition, the superior department sometimes only pays attention to the final results, and does not understand the actual situation on Changzhou side, it will put forward an unreasonable request. Therefore, it will cause some obstacles to management communication.

(3) The speed of statistics, sorting and feedback of information data is slow. During the peak period of online shopping, the data of major e-commerce companies will increase sharply within a day, and it will even exceed 10,000 per second during "Double 11". During the peak period of delivery and distribution, statistics of various sites is also changing all the time. At the same time, the network department needs to count many types of data. (Li, Liu, & Tang, 2009) Therefore, during the peak period of online shopping, the network will inevitably have statistical errors or inaccurate data. Inaccurate data will affect the Changzhou Distribution Center's estimate of the next peak online shopping period, which will have a knock-on effect.

Problems and causes of distribution

Because of the particularity of the peak period of online shopping, the number of express goods transferred from the Distribution Center, whether it is transferred out or transferred in, is several times that of normal times. Therefore, the Distribution Office (i.e. the allocation site) has the following problems in the operation during the peak period of online shopping:

(1) The site was out of stock. Express delivery is a sudden increase in express delivery received by express companies, which leads to the delay of sorting, and many express pieces are stuck in the departure station or transfer station, so that the express will arrive at the customer for a long time. (Hu, & Du, 2004) To some extent, the most fundamental causes of the warehouse explosion caused by the Distribution Office of Changzhou are: the lack of site and low sorting efficiency. The reasons for the explosion are as follows:

⊖ The logistics direction of express is relatively centralized, but the express network is polarized. B2B and C2C online stores are mainly concentrated in the southeast of China, such as the Yangtze River Delta and the Pearl River Delta, but consumers are distributed all over the country. One is that logistics is divergent, (Zhou, Xu, & Lyu, 2008) so the transfer station, such as Changzhou Distribution Center, has too many express destinations, which increases the workload of sorting personnel invisibly.

⊙ The Transfer Center Express is overstocked, and the primary and secondary stations are not deployed enough. Although the site capacity of Changzhou Distribution office is enough, however, due to the limited storage and distribution level of the sub stations in the community or supermarket, the warehouse and distribution level of the outlets is inevitable. (Ma, & Chen, 2007).

(2) People are difficult to control. During the peak period of online shopping, the quantity of express goods increased rapidly and the workload increased, which put forward higher requirements for the number of personnel and work efficiency; in addition, whether sorting or distribution, due to the increase of workload, these employees who do physical work will inevitably have emotions and affect the work efficiency. Therefore, for the distribution of personnel in the peak time of online shopping management is more difficult.

Problems and causes of customer service department

In the peak period of online shopping, the quantity of express goods increases rapidly and the delivery commitment of e-commerce to consumers makes the whole express logistics industry under great pressure. However, the emergence of various abnormal phenomena such as warehouse explosion, delayed delivery, problem parts and false sign in will bring dissatisfaction to customers. Therefore, in the peak of online shopping, customer service department will also have various problems in operation. The problems and causes are as follows:

(1) There are too many reminders and complaints, too late to deal with. Due to the occurrence of warehouse explosion, the delivery time of express shipments is prolonged, or the occurrence of problematic items, such as loss, damage, etc., customers

will complain and complain, so the complaints and inquiries received by the customer service department will be several times the usual. If the customer service staff is too late to deal with it, it will cause a vicious circle.

(2) Too many problems make it difficult to query. The express during the peak period of online shopping is mainly online shopping goods, which are very similar in size, packaging, shape, etc. if there are damaged or headless parts; it is difficult to distinguish the time customers come to check. For example, in 2019, "double 11", there are a lot of headless pieces in Changzhou Distribution Center of Huitong Express. Many customers come to ask the whereabouts of express, and there are many similar items when looking for them. Headless is a express that the waybill has been damaged during transportation, or the contact information and address of the addressee are unknown.

(3) The number of personnel is insufficient and the required professional skills are insufficient. Huitong Express has a system dedicated to the customer service department: CRM system. However, if the customer service personnel temporarily hired or transferred during the peak period of online shopping are not familiar with the CRM system, the processing efficiency will be affected during the use process.

Problems and causes of secondary site

Although the site is not the division center department, but directly by the Distribution Center management and monitoring. At the same time, Huitong Express currently uses the model of BEX direct business point Department of the network department, which has direct management of the distribution of small members. Therefore, the problems of each site are also the problems to be dealt with by Changzhou Distribution Center. During the peak period of online shopping, the problems and causes of the first and second-level sites are as follows:

(1) It is difficult to manage personnel. The main causes are: insufficient distribution personnel; the temporary employed express personnel are not familiar with the geographical distribution area, extending the distribution time; the express personnel are too tired and inefficient.

(2) The lack of site caused the explosion. The main causes are: insufficient site; unreasonable stacking, resulting in damaged or missing express.

(3) False signature. During the peak period of online shopping, Changzhou Distribution Center will take a certain performance appraisal method for each site, such as the daily delivery or sign in quantity. A bit of site in order to achieve the goal, may upload "signed in" information in the system, then send. In fact, it has caused false signing. False sign in is a serious behavior in express industry. May directly affect the site, the integrity of the company.

The difference between forecast and actual import and export

Before the peak period of online shopping, Changzhou Distribution Center will forecast the number of packages in the peak period of online shopping according to the previous data, and then adjust and supplement all the current personnel, venues, vehicles, etc. in order to meet the arrival of the peak period. However, there will still be differences between the forecast and the actual data, which lead to the following reasons:

(1) The handling and sorting efficiency of operators cannot be determined. The ability and level of staff are different, and the difference of work efficiency may cause the link between links not timely, which will delay the express logistics time.

(2) It is expected to be too conservative. If the data analysis of previous years is inaccurate or the existing resources of the Distribution Center are not well understood and deployed unreasonable, it will cause the prediction to be too conservative, which will cause the shortage of personnel, site and equipment when the peak time of online shopping really comes, which will cause the explosion.

The speed of the goods and transfer is slow and the efficiency is not high

As an organization specialized in the allocation activities, the most important function of the Distribution Center is transfer, which has both transfer out and transfer in at the same time, the distribution volume is generally large in the peak period of online shopping, which will restrict the quantity of goods received. In the process of transfer out, there are often problems of slow transfer out of site parts and arrival Distribution Center. The main causes of inefficiency are as follows:

(1) The personnel did not respond in time and could not reach the sender for the goods within the specified time after receiving the information of the contract.

(2) Too much delivery to upload information to the logistics system immediately. During the peak period of online shopping, the quantity of the delivery will be several times higher than usual. In case of a lot of daily quantity, it will be too late to input each waybill number into the system one by one. The actual parts have been hired or transferred, but there is no information display in the system because the information update is not timely.

(3) Lack of handheld terminals and improper use. The staff at the venue and the site will have their own handheld terminals, that is, the express scanner, which is divided into several modules such as sending, arriving, delivering, signing, and collecting. Before using the scanning gun, each operator must enter his or her job ID and password in the system. After entering the system, select the operation module he wants to perform, click the scan button, and align the scanner with the barcode on the waybill. After the beep sounds, it means that the information of the waybill has been entered into the upload system, and the customer or

the company's internal operators can check the status of the ticket in the system. The lack of handheld terminals and improper use will cause information to be updated in time.

The accuracy of small package is low

For online shopping, ordinary customers buy small goods (lighter, smaller volume and low value). Therefore, for online shopping small pieces sent to the same destination (divided into provincial and municipal level), small-sized package is adopted for convenient transportation and storage. In this way, the most important problem for the dial center is accuracy. The possible cause is the human problem, because the package needs manual operation so far.

COUNTERMEASURES TO IMPROVE THE OPERATION LEVEL

Forecast of online shopping in the early peak

Although the peak period of online shopping is sudden and the duration and the quantity of express messages are different every year, according to the statistics of Changzhou Distribution Center in the peak period of online shopping in previous years, some data and problems can be found to follow the general rules, which can be predicted in advance.

According to the data of 2019, the data that can be predicted are mainly:

- (1) The storage area that is needed is generally 100% - 100.5% of the usual. However, in case it could increase to 101%.
- (2) The duration of the peak. From 2019 data, the period of rapid increase in online shopping express is generally in the middle term, because the express from all over the country will be transported to Changzhou, usually lasting 5-7 days. Therefore, the sorting, distribution and site management of these days should be focused on.
- (3) The quantity of the delivery and the quantity of the dispatch. The quantity of outgoing goods refers to the express quantity transferred from Changzhou to the city, and the dispatch quantity refers to the express that the destination is the one transferred out from Changzhou. If the speed of dispatch is higher than the speed of the outgoing parts, it can reduce the pressure and relieve the phenomenon of warehouse explosion for the allocation site of Changzhou Distribution Center.

Do a good job in the preliminary planning

The plan is a macro plan for the whole by the top management. According to the forecast, the corresponding planning work is needed to alleviate the problems. Mainly have the following aspects:

- (1) Storage space, that is, the plan of the approximate area of the required site. To ensure that there is enough space to accommodate many express deliveries during the peak period, the site needs to be reasonably arranged on the basis of the predicted number, whether it is a re-planning of the existing site or Temporarily add new storage locations on the existing basis (Kim, 2020).
- (2) The personnel plan mainly includes the temporary addition and dispatch of each department in this special period, as well as the precautions for personnel operation in specific posts.
- (3) The plan of facilities and equipment includes the arrangement of facilities and equipment in different sites and different work, and preparation for the preliminary inspection of specific equipment. (Jiang, & Wang, 2005)
- (4) The plan of vehicles is sufficient for Changzhou Distribution Center, but due to the particularity of peak period, the vehicles can be readjusted to meet the needs of transportation and improve efficiency and alleviate the problem of explosion.

Reasonable planning of site to alleviate the insufficient storage location

The express delivery volume during the peak period of online shopping has the characteristics of suddenness and large quantity. If the express delivery and delivery are arranged after the peak period of online shopping, it will definitely be too late to cause the problem of warehouse explosion. To a certain extent, the main problem is the "explosion" of the distribution site. It can be seen from Figure 1 that for the Changzhou Distribution Center, the daily application utilization rate of the distribution site has reached more than 70%, especially the space occupied by local express mail, which reaches 87% in normal operations. the above. If enough space is allocated, no matter what the rapid increase rate of express shipments is, the degree of liquidation problem can be relatively reduced. Therefore, one of the most important tasks before the peak period of online shopping is to prepare the venue. There are several ways to alleviate the shortage of storage space.

Temporary borrowing of other sites

Huitong Express has a fast Distribution Center in Changzhou besides the express Distribution Center (responsible for the transfer of large-scale goods of large-scale companies with cooperation with Huitong), and the two distribution sites are adjacent. The distribution of the distribution site of express delivery and express transportation in daily situations is shown in Figure 6:

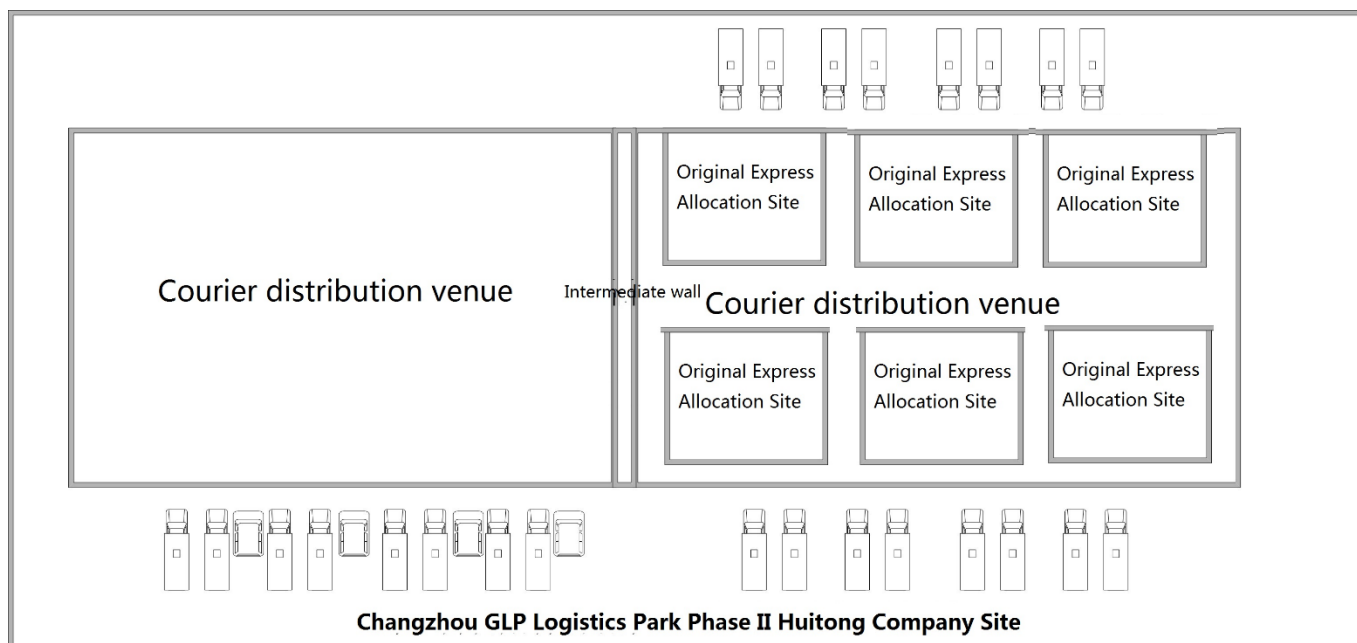

Source: This study

Figure 6: general distribution of remit express and express distribution in daily situations

Compared with express delivery, express transportation is a long-term cooperation, the sales of goods are relatively stable, and there is little sudden peak. Therefore, for the period of rapid increase of express delivery generated during the peak period of online shopping, it can be relieved by the distribution of express space. The adjusted site distribution is shown in Figure 7:

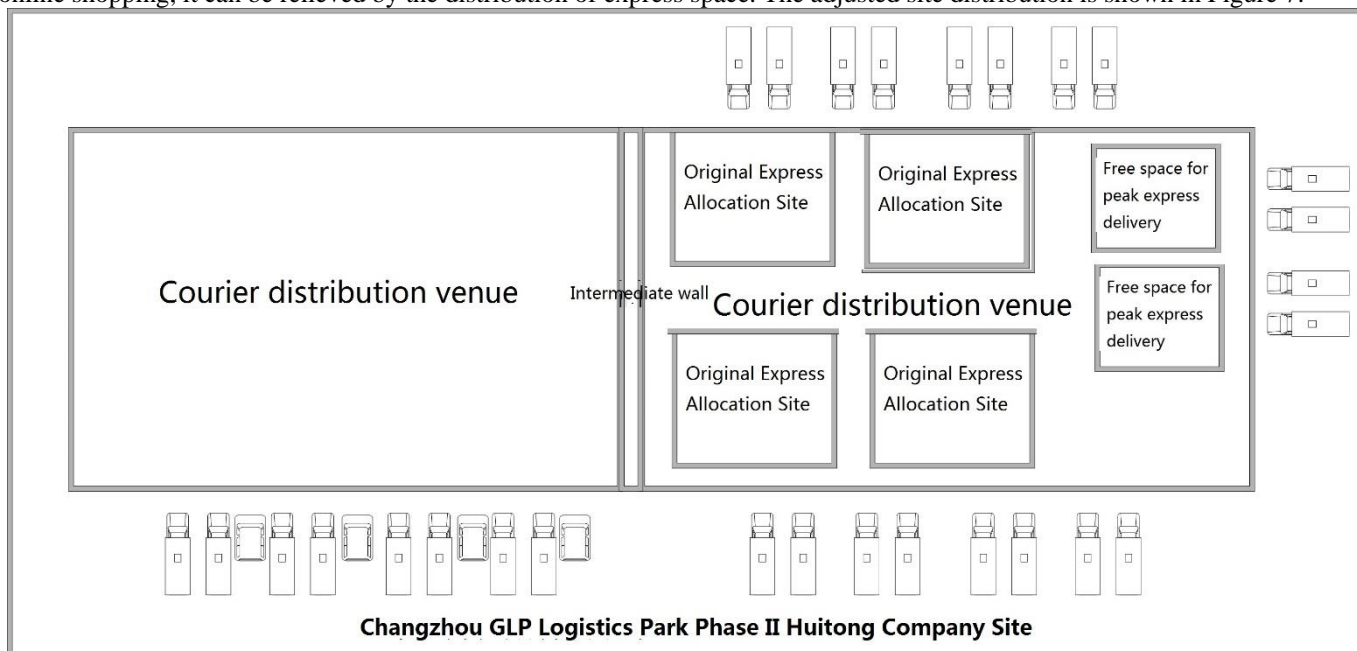

Source: This study

Figure 7: overall distribution of remit express and express distribution after adjustment

As shown in Figure 7, the transfer out of express goods is relatively stable, so the temporary free space in the express delivery site can temporarily alleviate the tension of the express distribution area. The details are shown in the two upper right corner of Figure 5. At the same time, because there is still a certain space on the other side of the express site, it can be used for the transportation vehicles in and out, which is very convenient and safe. The daily express transportation can still be handled through the front door and back door of the Distribution Center, and the transportation vehicles are also convenient to enter and exit (Demirta, Nurgül, & Tuzkaya, 2012).

Compared to temporarily renting other warehouses to transfer centers during peak periods, the use of existing express distribution sites saves a lot of cost, mainly reflected in: (1) site rental fees; (2) redesign of transportation routes Expenses, energy and time; (3) Arrangement and distribution of facilities and equipment in the leased site; (4) Staff arrangements for temporary sites. In addition, the time for online shopping peaks to appear and maintain each year is relatively short. For

temporary lease of venues, firstly, it is difficult to find a suitable address; secondly, general warehouses are unwilling to assume the lease period within one month.

Of course, the occupation of the express distribution site also needs to be prepared for relevant communication in advance, mainly as follows:

- (1) The paper analyzes the allocation of Daily Express Department, reasonably estimates that the express transportation is in the peak period of online shopping to reduce the allocation site and does not affect the feasibility of the operation in production.
- (2) The area of the site that may need to be occupied more during the peak period of analysis. According to Table 6, it can be concluded that the more sites needed for Changzhou Distribution are about 0.4% - 0.8%, namely 17.16m²-34.32m².
- (3) Express administration department and express department shall communicate with Express Department to borrow the site in advance to get understanding.
- (4) Reasonably plan the express location for the reserve space in the peak period at the Express office at least 2 days in advance.
- (5) Make the deployment of personnel, equipment and vehicles in the standby site in advance.
- (6) After the peak period, reply to the normal operation of the express in time and express our thanks.

Direct delivery

As for Changzhou Distribution Center of Huitong Express, there are no major problems in vehicle during the peak period of online shopping. Because of the lack of storage in daily operation, all express delivery through Changzhou, whether it is transferred out of the same city or transferred in other places, needs to be concentrated in Changzhou Distribution Center first, and the rapid volume increases greatly in the peak period of online shopping, which brings great pressure to the site of the Distribution Center. Therefore, if we can send some of the vehicles directly around the over dial center to the distribution network during peak period, the pressure of the storage in the Distribution Center can be relieved. Of course, direct delivery needs to do a series of other supporting work as follows:

- (1) Determine the distribution outlets for direct delivery. For the outlets that can be directly distributed, to allow the large-scale transportation vehicles that originally go to the main line directly into the branch line, the most important thing is that this or these outlets must have a large distribution volume. (Yu, & Xu, 2012). As for Changzhou, the outlets with large distribution volume mainly include Wujin, Jintan, Liyang, and Danyang stations managed by Changzhou Distribution Center.

Wujin is the largest area in Changzhou, and it is separated from the north and south ends of the city with the new North District where the Distribution Center is located. The G42 and S39 high-speed can be directly connected to the Wujin and exit, so the goods to be transported to Wujin can be sent directly. Jintan, Liyang and Danyang are all county-level cities, but because the cost of building large Distribution Centers is very high, they are usually managed by Changzhou Distribution Center. However, during the peak period of online shopping, one of the largest sites in the three county-level cities can be used as temporary small distribution centers, or temporary warehouses can be used to transport the three original distribution centers to Changzhou distribution centers. The express mails of county-level cities are diverted to free up storage space for express mails destined for downtown Changzhou, and it can also reduce the pressure of sorting in Changzhou distribution center.

- (2) Arrange sorting in advance. The direct delivery will inevitably change the sorting work of some parts. For the express to Jintan, the express of this part should be sorted and shipped for Changzhou according to the destination in the previous sorting work. However, after the direct delivery, the destination of the express is changed to Jintan. Therefore, the express sent to Changzhou city should be piled separately during sorting.

- (3) Coordinate cooperation with other Distribution Centers. In the direct delivery mode, some vehicles that were originally through Changzhou Distribution Center no longer pass through here, but directly to the distribution network, which is equivalent to the change of transportation route of some vehicles. In addition, the early sorting is in the previous level of the allocation center, which is equivalent to increasing the workload of other Distribution Centers. Therefore, it is necessary to communicate with the previous level of the Distribution Center in advance. Under the condition, the personnel can be added to the sorting center at the upper level and help can be provided to promote the normal operation of the whole express network.

Rationalization of personnel management

Adequate personnel

In the peak of online shopping, the problem of insufficient personnel mainly appears in sorting office, subordinate stations and customer service department.

- (1) Sorting office: according to the statistics of Huitong Express Changzhou Distribution Center during the period of "double 11" in 2019, the general explosion occurred after November 14, and reached the peak on 19 and 20, and the most direct reason for the explosion of the Distribution Center was the delay of express due to the low sorting efficiency. Therefore, the Distribution Center should focus on the dispatch of additional personnel to the sorting office in these days. If it is difficult to hire temporary workers, other departments can be mobilized to participate in sorting when necessary, such as colleagues from relevant express departments.

(2) Subordinate site: compared with the transfer site, the "explosion" is more often found in the lower level site. The main reason is that the site is insufficient, and the site personnel are generally not many, generally in 3-5, some small stations may only have two people, in the case of rapid increase in the peak online shopping, it is difficult to deal with it efficiently.

Huitong Express is different from other express companies, such as Yuantong, Zhongtong, etc. the most important point is that Huitong has a direct business BEX station and small members, which are directly managed by Changzhou Distribution Center. In peak hours, we should use BEX direct sales personnel as alternate members flexibly, and we can consider external temporary employees to relieve pressure. (Yu, Wang, & Liu, 2018)

(3) Customer service department: the number of complaints and inquiry items increased sharply during the peak period of online shopping, which often makes the telephone of customer service department burst. Although Huitong Express has its own customer service system, it can relieve the pressure on the telephone to a certain extent, but the daily problems handled by the customer service department in peak period will be 5-8 times that of the normal. The handling capacity of a customer service personnel in a day may reach 400 for the problems to be dealt with in the optical CRM system. Therefore, the customer service department should find temporary workers or interns as early as possible when preparing for the online shopping peak. On the other hand, because the customer service performance evaluation of Jiangsu Province is tied together, if there are not enough customer service personnel on Changzhou side, other cities, such as Nanjing, Zhenjiang and Suzhou, can be asked to assist in handling.

Training personnel skills

The skills training mainly involves the division, customer service and administration.

(1) Division: the most important part of the Distribution Center is sorting. At present, in Changzhou Distribution Center, besides the automation of conveyor belt and vehicle, sorting and packet collection work is mainly based on labor. Therefore, the operator should be trained properly (Gao, Li, & Li, 2017), such as the use mode and specification of the handheld terminal, mainly the hand-held express scanning gun. It also needs training on the use of conveyor belt and the standard operation of small package in the distribution site.

(2) Customer service department: train the service specification of customer service personnel. The main purpose is to standardize the terms of receiving the phone. Before the customer service personnel take the post, the director of customer service department should teach the basic politeness language model to the new customer service. Adopt different telephone terms in the face of different types of customer requirements; on the other hand, the operation training of customer service system, mainly the use of CRM system and Q9 system in the work.

Increase and make reasonable use of the guidance of professional personnel

For the improvement of working efficiency in the peak period of online shopping, in addition to the previous data analysis, we need to have professional knowledge as the basis. (Zhang, Jin, Song, & Dan, 2010) Therefore, we should strengthen the cultivation of talents in the industry and attach importance to the cultivation of high-end talents in the field of e-commerce. Encourage universities, scientific research institutions and enterprises to achieve collaborative innovation. On the other hand, for the first-line express delivery staff, we should strengthen the recruitment and training management, improve the quality of the employees, and ensure the end-user experience.

In the peak of online shopping, we should make full use of the skills of express logistics professionals, and mobilize the enthusiasm and self-confidence of employees in the face of the peak period of online shopping, so as to be fully prepared. Meanwhile, the overall situation shall be mastered during the period, and the fact monitoring and reasonable adjustment of personnel and equipment shall be conducted.

Reasonable division of labor and full use of reward and punishment system

During the peak period of online shopping, you should not be busy with the large amount of express mail. At this time, you should divide your work reasonably and perform your own duties. As the direction indicator of an enterprise, senior leaders should grasp the overall situation and formulate corresponding reward and punishment systems while boosting morale to maintain the achievement of various indicators. For example, you can give staff, especially manual sorters and dispatchers, sufficient rest time before the peak of online shopping; during the peak of online shopping, provide extra meals for personnel in various departments, especially when the problem of warehouse explosion is serious. A few days; do a good job of emotional comfort.

Accelerate automation

For Changzhou Distribution Center, automation means that more machines are used in the configuration of equipment and facilities instead of labor. On the one hand, it can avoid the shortage of labor; at the same time, it is also a way to reduce the cost in the end. (Han, 2006).

The most important thing for the distribution center is the application of fully automated sorters. The data shows that the working capacity of a fully automatic sorter can reach 6000-7700 express items per hour, while the error rate will remain below

1%; and the current manual operation workload is about 150 express items per hour. The error rate is usually above 3% (Chen, Langevin, & Riopel, 2011). At the same time, the automatic sorter can sort many goods steadily for a long time regardless of time, weather, energy, mood, and other factors. Therefore, compared with manual sorting, the fully automatic sorter has the advantages of stability, low energy consumption and low cost in the end.

In addition, the equipment implementation of Huitong Express Changzhou Distribution Center mainly includes vehicles, hand-held terminals, sites, shelves, water conveyor belts, forklifts, pallets, lifts, etc. In the peak of online shopping, the following points should be achieved:

- (1) According to the experience of previous peak online shopping, the quantity and model of required facilities and equipment shall be predicted in advance, and the quantity of preparation shall be greater than required, and the existing equipment shall be checked in advance for good use.
- (2) In the ordinary management, this equipment should be checked regularly. If there is a sudden equipment failure during the peak period of online shopping, both the maintenance cost and the operating profit are double consumption.
- (3) Conduct standardized operation guidance, such as training and guidance for operators before equipment use; posting operation specification instruction at obvious places of equipment.

The process of rapid increase information

In order to reduce the occurrence rate of "explosion" and "problem parts" in the peak period of online shopping, the importance of information flow to logistics is self-evident. It is necessary to apply various system software to the operation of Huitong Express Distribution Center more flexibly to speed up its informatization process (Lee, & Kwon, 2010).

- (1) Q9 system, with many modules and powerful functions, belongs to a comprehensive system, and the Distribution Center is mainly used for checking the parts
- (2) OA platform, which belongs to the internal system of the company, is used for the update of internal information at any time, the release of notices, etc. Network department and customer service department need to pay attention to the information on the platform frequently, so as to timely understand the latest decision-making and operation status of the head office and superior departments, and adjust the operation in combination with the actual situation on Changzhou side.
- (3) CRM system is a special customer service system, which is used for the input and processing of LCs problem parts. But the application rate of CRM system in practice is still lower than that of customer service telephone. On the one hand, the number of customers using network complaints and queries is a small number; on the other hand, the situation that CRM system can handle is still limited, and needs to be improved and maintained constantly.

CONCLUSION

The rapid development of network technology and electronic payment has made online shopping a very important part of modern life. In order to attract consumers, major domestic e-commerce platforms are racing to launch online shopping promotion festivals. Among them, Taobao's "Double 11" is the main hit. The explosive increase in transaction volume during the peak period of online shopping places high demands on express logistics, which has led to various problems. Among them, the problem of "explosion" in distribution centers and subordinate sites is particularly prominent. As an important transfer link in express logistics, the distribution center is a logistics base that integrates processing, tally, and delivery functions, and has functions such as storage, sorting, collection and distribution, and connection. Therefore, once the distribution center has operational problems, it will affect the entire express logistics process. This article takes Huitong Express Changzhou Distribution Center as an example, based on the actual situation, uses theory to put forward suggestions to improve the express service quality and improve the operation efficiency of the distribution center, so that the operation is more reasonable and efficient. Hope it has a certain meaning to the operation of Huitong Express Changzhou Distribution Center.

In short, the efficient operation of the distribution center is a process of continuous optimization, which is of great significance to the efficiency of express delivery during the peak period of online shopping. At present, the development of the express industry is still lagging behind the development speed of e-commerce. Therefore, it is necessary to continuously learn advanced technology and experience. Continuous optimization can make the operation efficiency of the express distribution center be further improved.

ACKNOWLEDGMENT

This work was financially supported by research project of Jiangsu Provincial Department of Education University Philosophy and social science 2017: Research on the upgrading of public technology service platform for small and medium-sized enterprises in Jiangsu Province under the background of "Internet +" era (2017SJB0402), China. Research on the Informatization Upgrade of Jiangsu Small and Medium-sized Service Enterprises under the Background of "Internet +" (2017SJB0673), China.

REFERENCES

- [1] Chen, L, Langevin, A, & Riopel, D (2011). Dynamic Relocation Problem in an Automated Storage/Retrieval System. *Journal of Shanghai Jiaotong University*, 45(1), 116-119. doi: 10.16183/j.cnki.jsjtu.2011.01.024 (in Chinese).
- [2] Demirta, Nurgül, & Tuzkaya, U. R. (2012). Strategic planning of layout of the distribution center: an approach for fruits and vegetables hall. *Procedia Social & Behavioral Sciences*, 58(10), 159-168. doi: 10.1016/j.sbspro.2012.09.989
- [3] Gao, Q.X., Li, R.Z., & Li, J. (2017) Formulation and selection of new staff training program based on system dynamics. *Computer Integrated Manufacturing Systems*, 23(1), 5113-122. doi: 10.13196/j.cims.2017.01.013 (in Chinese).

- [4] Han, Q.L. (2006). Multi-target Optimization Model of Logistics Establishment Programming. *Control and Decision*, 21(8), 957-960. doi: 10.13195/j.cd.2006.08.119.hanql.026 (in Chinese).
- [5] Hu, D.W., & Du, M. (2004) Research on the planning of logistics distribution center. *China Journal of Highway and Transport*, 17(4), 114-118. doi: 10.19721/j.cnki.1001-7372.2004.04.025 (in Chinese).
- [6] Jiang, Z.Z., & Wang, D.W. (2005) Research on Optimal Design of Logistic Distribution Center for B2C E-Commerce. *Journal of Northeastern University (Natural Science)*, 26(8), 730-732.
- [7] Kim, T. Y. (2020). Improving warehouse responsiveness by job priority management: A European distribution center field study. *Computers & Industrial Engineering*, 139(1), 105564.1-105564.12. doi: 10.1016/j.cie.2018.12.011
- [8] Lee, Y. H., & Kwon, S.G. (2010). The hybrid planning algorithm for the distribution center operation using tabu search and decomposed optimization. *Expert Systems with Applications*, 37(4), 3094-3103. doi: 10.1016/j.eswa.2009.09.020.
- [9] Li, L., Liu, S.X., & Tang, J.F. (2009) Model and Algorithm for Distribution/Delivery of Goods on Order in B2C E-commerce. *Journal of Northeastern University (Natural Science)*, 30(11), 1554-1557.
- [10] Ma, S.H., & Chen, T.W. (2007). Elements & evaluation method of supply-chain-based logistics service capability. *Computer Integrated Manufacturing Systems*, 13(4), 744-745. doi: 10.13196/j.cims.2007.04.122.mashh.019 (in Chinese).
- [11] Wang, Z., & He, W.W. (2007) Planning & Its Application of Distribution Center Based on Order Data Analysis. *Chinese Journal of Mechanical Engineering*, 43(4), 173-177
- [12] Yu, H.Y., & Xu, Y.F. (2012). Strategy for supplier's direct delivery to minimize the number of vehicles. *Systems Engineering-Theory & Practice*, 32(12), 2672-2676.
- [13] Yu, D.J., Wang, J.J., & Liu, C.F. (2018) Approach to optimal staff assignment in workflows based on collaboration patterns. *Journal of Software*, 29(11), 3340–3354 doi: 10.13328/j.cnki.jos.005483 (in Chinese).
- [14] Zhang, X.M. Jin, L., Song, H., & Dan, B. (2010) Outsourcing contract with third-party logistics distribution center under manufacturer's supervision. *Computer Integrated Manufacturing Systems*, 16(12), 2736-2741. doi: 10.13196/j.cims.2010.12.194.zhangxm.031 (in Chinese).
- [15] Zhou, X., Xu, M.Z., & Lyu, Q.G (2008) Two-stage lay out optimization model for distribution center and terminal node under B2C mode. *Computer Integrated Manufacturing Systems*, 14(3), 588-594. doi: 10.13196/j.cims.2014.12.026 (in Chinese).

Research on the Regional Cooperative Innovation in Guangdong-Hong Kong-Macau Greater Bay Area

(Full paper)

Haiyun Qiu, College of Management, Shenzhen University, China, 2017047016@email.szu.edu.cn
Jin'e Jiang, Greater Bay Area International Institute for Innovation, Shenzhen University, China,
745390965@qq.com

Wanying Li, Greater Bay Area International Institute for Innovation, Shenzhen University, China,
winnielwy354@163.com

Yichang Hao*, Greater Bay Area International Institute for Innovation, Shenzhen University, China,
790420568@qq.com

ABSTRACT

Regional collaborative innovation is an important issue in the development of Guangdong-Hong Kong-Macao Greater Bay Area. It promotes the exchange of science and technology resources among cities and regions, and realizes the coordinated development of science and technology in the Great Bay Area. This study examines the collaborative development in the Great Bay Area from the perspective of regional collaborative innovation. The development of regional collaborative innovation is mainly composed of four elements: finance, science and technology, transportation and education. In the case of Shenzhen-Hong Kong Youth DreamWorks in the Qianhai Shenzhen-Hong Kong Cooperation Zone, this study obtains the residents' views on the collaborative development of science and technology innovation, as well as the evaluation of the performance of the four major elements by questionnaire survey. This study will provide suggestions for the Greater Bay Area to further strengthen collaborative innovation and deepen mutual cooperation in the future development.

Keywords: Guangdong-Hong Kong-Macau Greater Bay Area (GBA), Regional Collaborative Innovation, Qianhai Shenzhen-Hong Kong Youth DreamWorks.

*Corresponding author

INTRODUCTION

In order to promote the better development of city-clusters in South East China, and to build a world-class bay area as the base of scientific and technological innovation, the CPC Central Committee and the State Council issued the *Outline Development Plan for the Guangdong-Hong Kong-Macao Greater Bay Area* in 2019 (Central Committee of the Communist Party of China & State Council, 2019). The plan aims at giving full play to the comprehensive advantages of Guangdong, Hong Kong and Macao, deepening the cooperation between mainland and special administrative regions, and building the Greater Bay Area into a world-class urban agglomeration and one of the world economic centers against the world's top Bay area. The Guangdong-Hong Kong-Macao Greater Bay Area (GBA) is mainly composed of nine cities, including Hong Kong, Macao, Guangzhou and Shenzhen. This paper studies how the cities in the GBA develop through cooperative innovation. We do not only develop and perfect the related theory of regional cooperative innovation development, but also provide policy suggestions to improve the level of regional cooperative innovation in the GBA.

It has been pointed out that because of the different proportions of industrial structure in the Pearl River Delta region, the unbalanced overall state of industrial spatial distribution, and the great differences between developed and underdeveloped cities, the collaboration between these cities has become an inevitable choice, so as to enhance the effect of industrial transformation and upgrading (Zhao, 2011). Due to the existing complex problems and situations, it is necessary for different players, including local governments, enterprises, colleges and universities to cooperate to promote industrial transformation and upgrading in the GBA (Rubach, 2013).

In the field of finance, Peng (2015) has done a research on financial cooperation between the Pearl River Delta and the Yangtze River Delta region, and found that the degree of financial connection between cities is not only affected by the distance between cities, but also by the administrative region. Therefore, to promote the development of regional finance towards integration, the government should strengthen the construction of regional financial system, market and infrastructure, as well as the regional cooperation in financial supervision to prevent risks.

Yan *et al.* (2019) analyzed the innovation ability of various cities in the Pearl River Delta region. They pointed out some issues in scientific and technological collaborative innovation in the Pearl River Delta region. Firstly, the level of scientific and

technological innovation varies greatly among the cities, which manifests in the restriction on the innovation ability of science and technology industry. Secondly, under the influence of higher education, the quantity and quality of scientific research talents in Guangzhou and Shenzhen are far superior to other cities. Finally, the distribution of scientific and technological innovation resources in the Pearl River Delta region is not balanced, and there is a disconnection between the transformation and application of innovation achievements.

Zhang & Wen (2017) had different point of views. They analyze the relationship between regional collaborative innovation, innovation performance and regional integration by constructing a variety of models. They suggested that the innovation resources in Pearl River Delta region should be used efficiently and fairly allocated. It is also important to strengthen the circulation of the innovation elements, which means to transfer the endogenous driving forces which play a small role in Guangzhou and Shenzhen to other prefectural cities. As a result, it would improve the utilization rate of innovation elements and enhance the cooperative innovation ability of the surrounding cities, so as to promote the development of prefecture-level cities.

Despite the heated debates with various angles of points on this field, there are few discussions in the perspectives of the GBA residents towards the collaborative innovation of this area, who are the major actors and get mostly influenced by the relevant policy and development. In this study, we are going to analyze the case of Shenzhen-Hong Kong Youth DreamWorks in Qianhai Shenzhen-Hong Kong Cooperation Zone, so as to understand the major transformations brought by the GBA collaborative innovation. Then we collect the comments from the residents of GBA. As a supplemental angle of points to the former studies, the GBA residents' evaluations are valuable for us to understand the effects and defects of the collaborative innovation. It also contributes to the suggestions to promote the policy and strategy in the construction and collaboration of the GBA, which forms the last part of this paper.

CASE SELECTION AND ANALYSIS

Case Selection and Background

In this paper, Shenzhen-Hong Kong Youth DreamWorks in Shenzhen Qianhai Shenzhen-Hong Kong Cooperation Zone is selected as the case study, and suggestions are provided for the construction of the Greater Bay Area from the experience of collaborative innovation in Qianhai Shenzhen-Hong Kong Cooperation Zone. Qianhai Shenzhen Hong Kong Cooperation Zone is also called Qianhai Shenzhen-Hong Kong Modern Service Cooperation Zone (hereinafter referred to as "Qianhai ") (Zhong & You, 2019). Qianhai located at the junction of Nanshan District and Bao'an District of Shenzhen, that is, the west of Nanshan Peninsula and the east side of Lintin, covering an area of about 15 square kilometers. Qianhai was established according to the "Overall Development Plan of Qianhai Shenzhen-Hong Kong Modern Service Cooperation Zone" approved by the State Council in 2010. With the experience of development and construction in Shenzhen and Hong Kong, Qianhai exerts its unique advantages in design planning, system and mechanism, operation and management, etc., and has carried out various exploration and innovation, which has promoted the development of Shenzhen and even the Pearl River Delta region.

Case Analysis

Through summarizing the research of incubator service, this paper analyzes the services provided by Shenzhen-Hong Kong Youth DreamWorks including policy support, management structure, human resources, entrepreneurial support, life service, financing support and legal support.

In Qianhai Shenzhen-Hong Kong Cooperation Zone, Shenzhen and Hong Kong have carried out industrial cooperation, talent cooperation and rule of law cooperation in various aspects. Shenzhen-Hong Kong Youth DreamWorks (hereinafter referred to as "DreamWorks") is one of these cooperation projects. DreamWorks is a public welfare platform which assembled Shenzhen and Hong Kong's various advantages of resources to support and cultivate Hong Kong and Macao youth innovation and entrepreneurship. It is able to accommodate more than 150 entrepreneurial enterprises, including the field of mobile cultural creativity, the Internet and intelligent hardware. DreamWorks, with the concept of "innovation-oriented international maker community", has created a unique ecosystem of innovation and entrepreneurship. The ecosystem includes the normal operation coordination mechanism of Shenzhen and Hong Kong, as well as six platforms and eight full-chain entrepreneurial service systems, which includes entrepreneurial services, incubator clusters, think tanks, investment and financing, publicity and promotion, and international roadshow centers. These platforms have eight functions: work, exchange, training, service, display, financing, fitness and residence.

Support from professional management and service institutions

DreamWorks has set up a professional service and management organization, that is, DreamWorks Division, which provides the youth of Shenzhen, Hong Kong and Macao a series of consulting and management services such as entry, office space, policy facilities, financing, law, etc. It also conducts supervision and management of the operation activities of the enterprises in the park to assist the industrial and commercial departments, tax departments and other state departments.

Talent introduction and support

In addition to the unified new talent rental and living subsidy policy in Shenzhen, DreamWorks has also formulated a "Peacock Plan" for top talents, which sets standards to classify all kinds of talents and provides certain incentive subsidies to the identified talents.

Support for entrepreneurship

DreamWorks provides some support for individual makers, creators teams and enterprises entrepreneurship project which has been applied and recognized. At the same time, DreamWorks will also give a certain funding to encourage all kinds of organizations to provide public welfare training, consulting, R & D and promotion services.

Support for living and working facilities

DreamWorks provides all kinds of working hardware and software facilities for entrepreneurs, and also creates a "YOU+ youth entrepreneurial district" in the aspect of life service in order to provide clean and comfortable talent apartments, delicious restaurants and convenience stores for entrepreneurs in Shenzhen, Hong Kong and Macao and to solve the problems in the life of entrepreneurs. At the same time, DreamWorks makes reasonable plans in traffic routes, bus stops and direct buses to solve travel problems.

Investment and financing support

Based on the advantages of Qianhai financial industry, DreamWorks offers a roadshow platform for entrepreneurs to invest and finance, so that entrepreneurs can better obtain funds for innovative entrepreneurship undertakings. In addition, the settlement of a large number of high-quality Hong Kong and Macao enterprises have a positive impact on funds raise of young people in Shenzhen, Hong Kong and Macao.

Legal support

DreamWorks has created the Shenzhen Customer Legal Service Center, which is the first comprehensive platform to provide one-stop legal services for entrepreneurs. Entrepreneurs can obtain legal advice and assistance through online Internet platforms and offline legal centers. In addition, Shenzhen Makers Law Center also set up a comprehensive platform for creators to connect with law firms, accounting firms, intellectual property protection agencies and other related institutions to provide corresponding rights and interests protection.

EMPIRICAL RESEARCH

Purpose and Form of the Study

This empirical study adopts the method of a questionnaire survey, which is about the expectations and suggestions of the Greater Bay residents for promoting the development of the GBA regional collaborative innovation. The purpose of the study is to explore the ways of the GBA regional collaborative innovation development from the perspective of residents.

Questionnaire Design

Referring to the relevant regional collaborative innovation materials (ÓhUallacháin & Kane, 2015), as well as some psychological questionnaires, this questionnaire designed a total of 15 questions. The content can be divided into three parts, the first part is the personal related information survey, the second part is the most important part of the questionnaire and the third part is an optional essay question. The design of the questionnaire refers to "cognitive model", that is, "What, How, Why". Firstly, it discusses the nature of things, and then it studies how and why to do so. This questionnaire design starts from the GBA residents' understanding of the construction of the Greater Bay Area, and then collects suggestions for the development of cooperative innovation, so as to obtain the direction of cooperative innovation development in the Greater Bay Area.

In the first part, there are five questions, which mainly investigate the basic characteristics of residents, including age, sex, education, income and occupation. From these basic indicators, the cognition and preference of the group on the development of collaborative innovation in the Greater Bay Area are analyzed.

The second part has 9 questions, mainly from three dimensions of content design. First of all, this study investigates the residents' attitude towards the cooperative innovation and development of the Greater Bay Area. Secondly, based on the results of the case study above, we analyze the influencing factors, cooperation fields and participants of regional collaborative innovation development, and apply the results to the questionnaire so that the residents' attitudes and preferences towards the relevant factors of regional collaborative innovation can be investigated. Finally, the study investigates the possible impact of regional collaborative innovation on residents' lives and gives corresponding suggestions.

The third part has only one essay question, which is designed to collect the suggestions from the respondents for the development of collaborative innovation in the Greater Bay Area.

According to the psychology of the people who fill in the questionnaire, the seriousness of filling out the first half is higher than that of the second half, so we put the main part of the questionnaire that needs more thinking on the first page of the questionnaire, and the second page includes the first part and the third part.

Data Collection

The data collection of the questionnaire was conducted in the form of online questionnaire, and the data was collected by forwarding WeChat friends and WeChat Moments. A total of 283 questionnaires were collected, of which 283 were valid. After the data collection, the author exported the relevant data powered by www.wjx.cn, and uses the SPSS statistical software for analysis.

Analysis of Findings

Reliability analysis

Reliability analysis (Ho, 2006) is an effective analysis method to evaluate the reliability of comprehensive evaluation system. Cronbach's α coefficient reliability analysis was used in this questionnaire. The value of Cronbach's α coefficient is between 0 and 1, and the closer the value is to 1, the higher the internal reliability of the scale is. When the number of items is definite, if the Cronbach's α coefficient is greater than or equal to 0.9, the internal reliability of the scale is considered to be high; If the Cronbach's α coefficient is $0.7 \leq \alpha < 0.9$, the internal reliability is considered to be high or acceptable; If the Cronbach's α coefficient is between 0.6 and 0.7, the design of the scale is considered to be problematic but still has reference value; If the Cronbach's α coefficient is less than 0.6, the design of the scale is considered to be problematic and should be redesigned.

According to the reliability analysis of the above analysis method, the results are as shown in Table 1. It can be seen that the α coefficient of the study scale is $0.908 > 0.9$, so it can be concluded that the internal reliability of the questionnaire is high and the design of the scale is reliable.

Table 1: Reliability analysis table.

Cronbach's α	0.908
Cronbach Alpha Based on Standardization Terms	0.922

Validity analysis

Validity analysis is a method to evaluate the effectiveness and accuracy of questionnaire design. KMO test and Bartlett's test were used in this questionnaire. In the analysis, if the value of the KMO test is greater than 0.7 and the probability P value of the Bartlett's test is less than 0.05, it indicates that the questionnaire has good structural validity.

According to the above analysis method, the validity analysis is carried out and shown in Table 2 below. It can be seen that the KMO value is $0.889 > 0.7$, and the Bartlett sphericity test value is $0 < 0.05$, indicating that the questionnaire has good validity and accuracy and good structural validity.

Table 2: Validity analysis.

KMO sampling fitness	0.889
Test of Bartlett's Spherical Shape	0.000

Basic descriptive statistical analysis

The basic descriptive statistical analysis of the sample includes six indicators: age, sex, education level, monthly income, occupation and city. A total of 283 questionnaires were collected. The basic description of the statistical results is shown in Table 3 and Figure 1 below. Based on the comprehensive analysis of the results of this questionnaire, the characteristics are as follows: (1) the age distribution is mostly between 18 and 25 years old, which accounts for a large number of people; (2) Female investigators are more than male; (3) Most of the investigators have junior college or bachelor's degree; (4) The

monthly income is mostly below 5000 yuan, followed by 5001 yuan to 10000 yuan; (5) More than half of the survey respondents are students, followed by the enterprise staff; (6) Most of the respondents live in Shenzhen.

Table 3: Statistical tables for basic descriptions.

Statistical variables		Number of people	Percentage
Age	18-25 years	223	78.8
	26-35 years	35	12.4
	36-45 years	13	4.6
	Over 46	12	4.2
Gender	Male	105	37.1
	Female	178	62.9
Cultural level	Junior high school and below	5	1.8
	Secondary or high school	25	8.8
	Junior college or undergraduate	229	80.9
	Graduate and above	24	8.5
Monthly income	RMB5000 or less	197	69.6
	RMB5001 to RMB10000	49	17.3
	RMB10001 to RMB15000	15	5.3
	RMB15,000 and above	22	7.8
Occupation	Students	188	66.4
	Staff of organs and institutions	8	2.8
	Enterprise staff	39	13.8
	Professional and technical staff	8	2.8
	Self-employed	8	2.8
	Service Industry Personnel	7	2.5
	Freelance	8	2.8
	Other	17	6.0

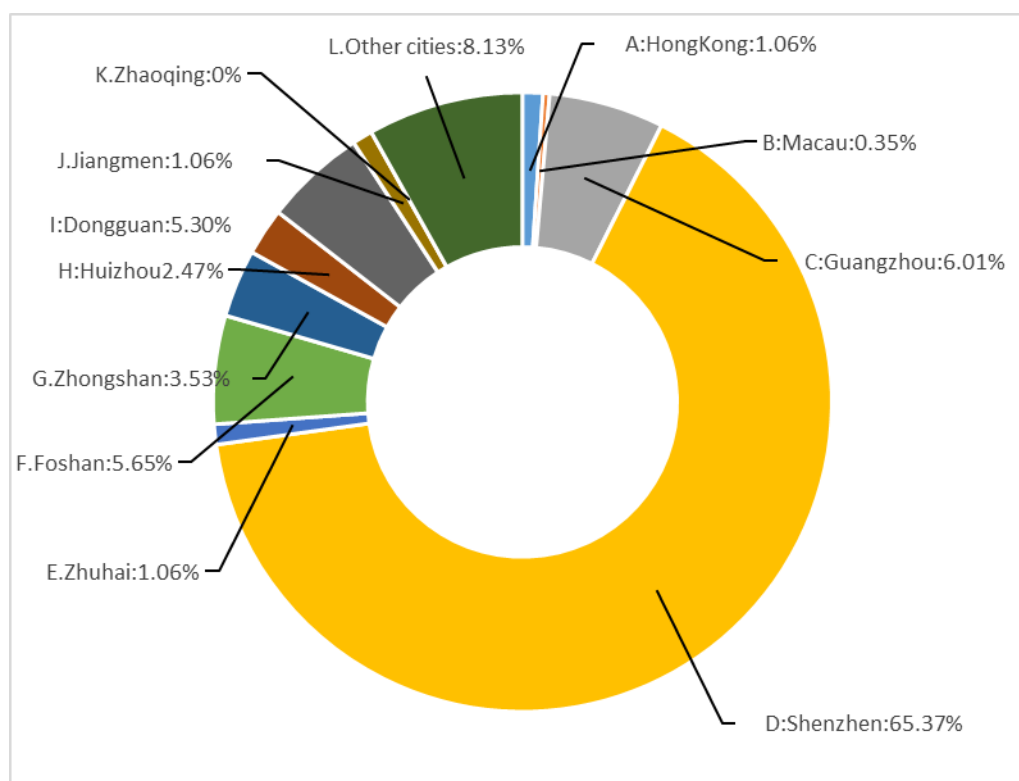

Figure 1: Urban distribution.

Cognitive analysis

At the beginning, the questionnaire firstly found out the surveyor's understanding of the construction of the GBA. The results are shown in Table 4 and Figure 2. It can be seen from the results that most residents of the Greater Bay Area still have some understanding of the policies and measures adopted by the central government to demarcate the GBA, but most residents only have a little understanding. Therefore, the government could increase publicity and popularize relevant policies among residents, thereby enhancing residents' initiative in building the Greater Bay Area.

Table 4: Analysis of residents' perception of the Greater Bay Area.

Did you know that the central government divides the Guangdong-Hong Kong-Macao Greater Bay Area?	
yes	248
No (skip the next question)	35
How much do you know about the construction of the Greater Bay Area?	
Know well	20
Better understand	33
Understand a bit	101
Know but don't know much	72
Don't understand	22

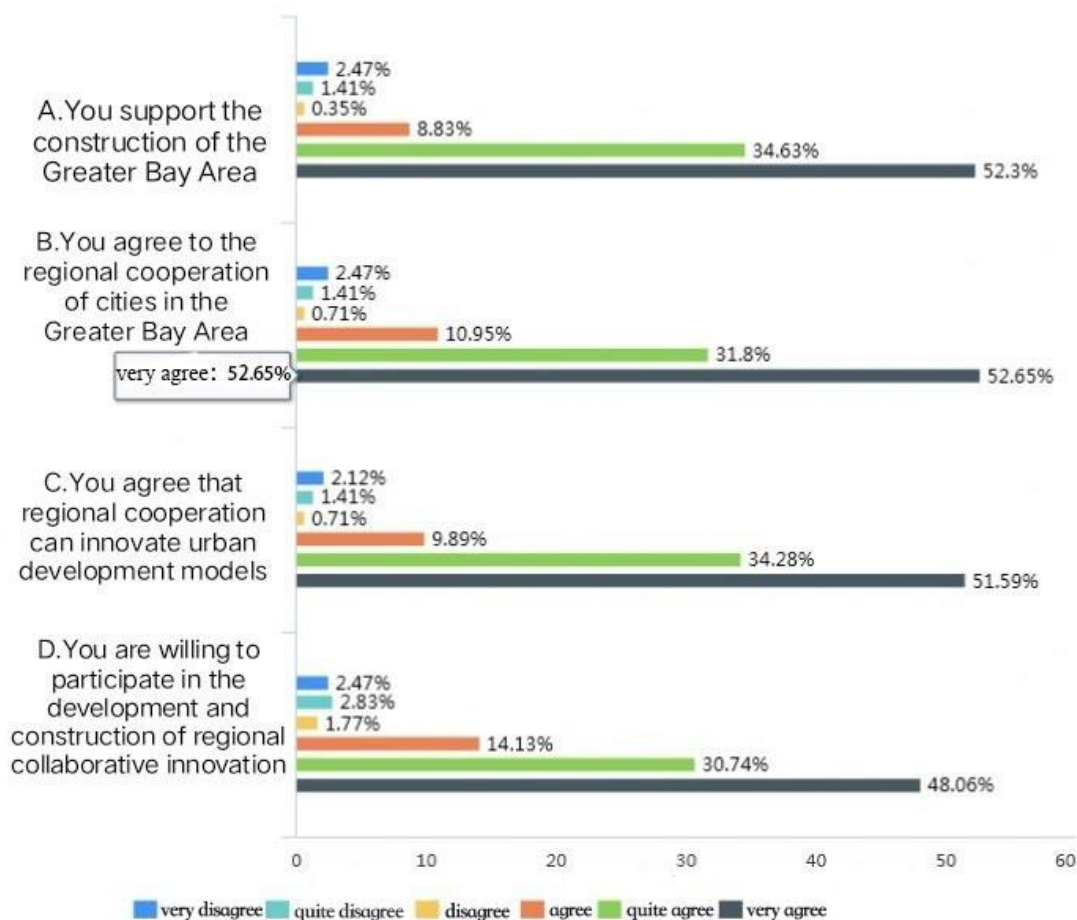

Figure 2: Residents' support for the construction of the Greater Bay Area.

Perception analysis

From the above case analysis, it is concluded that regional collaborative innovation is often carried out in the fields of finance, technology, transportation, and education (Tucker, 2008). The survey results are shown in Figure 3. The results of the questionnaire survey are consistent with the results of the case analysis. It can be seen that in the process of collaborative innovation and development in the Greater Bay Area, attention should be paid to the above mentioned four fields. Among them, taking the average value, the largest value is technology and transportation, which are 5.30 and 5.23 respectively. The higher the average value, the more importance the residents attach to it. Therefore, the top priority of the collaborative innovation and development of the GBA is technology and transportation.

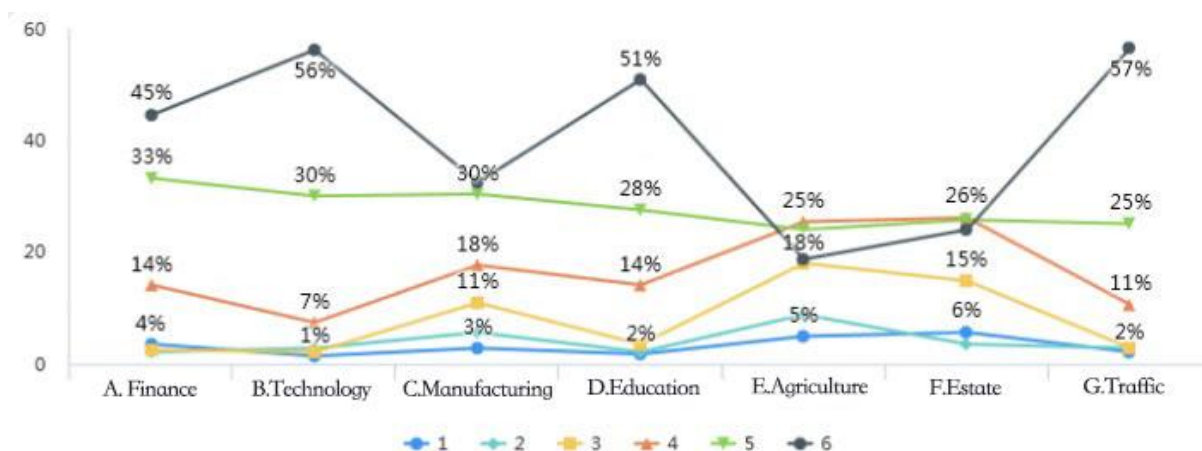

Figure 3: Analysis of the fields of regional collaborative innovation.

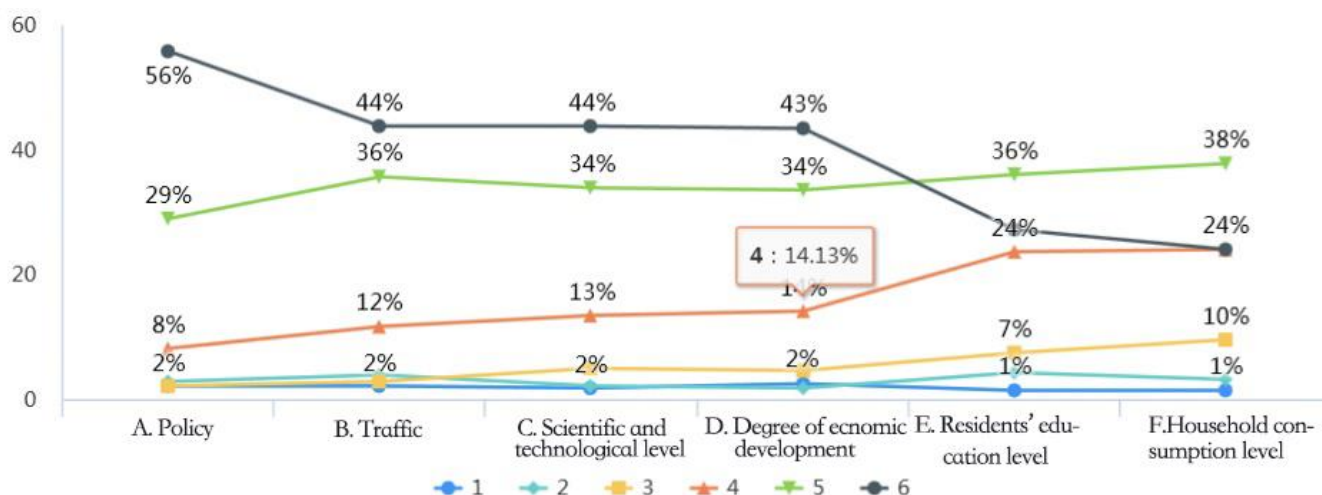

Figure 4: Analysis of the influencing factors of regional collaborative innovation.

The Figure 4 shows the degree of influence of different factors on regional collaborative innovation considered by residents of Guangdong, Hong Kong and Macao. From the survey results, it can be seen that the development of regional collaborative innovation is affected by many factors. Among them, policy, transportation, technological level, and economic development have the greatest influence on the development of regional collaborative innovation, followed by residents' educational level and consumption level. Among them, the policy with the largest average value is 5.27, indicating that the design of superstructures and policy guidance play a key role in regional collaborative innovation and development.

Therefore, the government should listen to the opinions and suggestions of all parties and formulate comprehensive policies to provide guidelines for the construction of the GBA. The development of regional collaborative innovation requires the participation of multiple subjects. Here we investigate the residents' preference for the degree of dominance of each subject. The results are shown in Figure 5. Residents generally believe that the government should play a leading role in the development of regional collaborative innovation, followed by enterprises and universities. This reflects the residents' support and dependence on the government to a certain extent. The results show that the government should play its leading role and guide all entities to actively and orderly participate in the construction of the GBA.

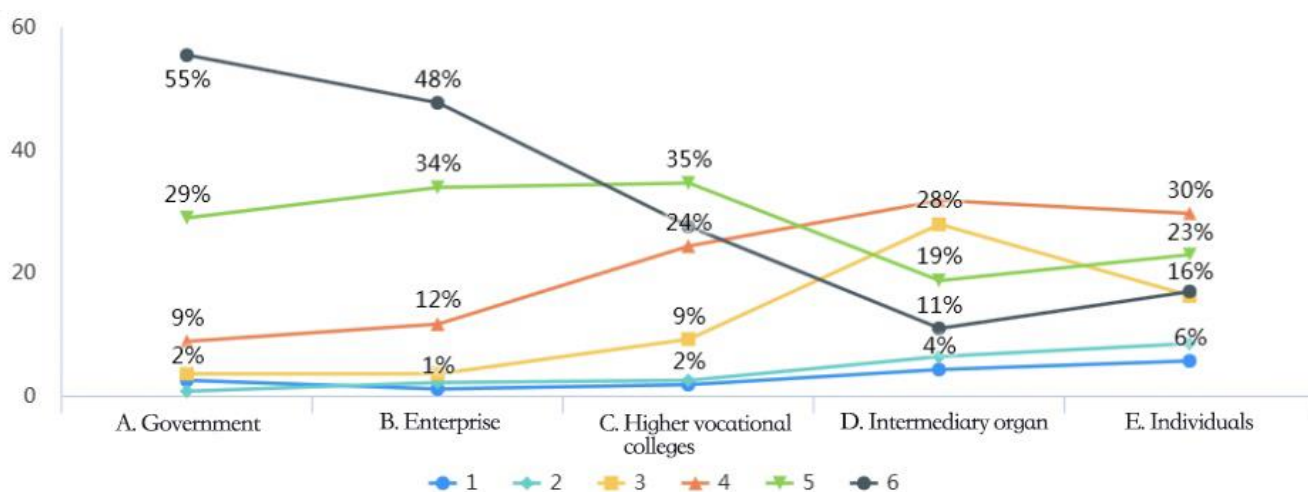

Figure 5: Analysis of the degree of dominance for entities in the regional collaborative innovation.

During the construction of the Greater Bay Area, all aspects of residents' lives will be affected. The survey results are shown in Figure 6 and Figure 7. According to the average results, transportation has the greatest impact on life, followed by work, and then the use of technology products. This shows that residents believe that the construction of the Greater Bay Area is conducive to promoting the construction of transportation facilities, shortening the travel time between cities, and improving the convenience of residents' travel. In the process of gradual improvement of basic transportation facilities in the Greater Bay Area, residents of the GBA believe that work methods and locations may also change accordingly. At the same time, residents believe that the regional collaborative innovation of the Greater Bay Area will promote the development of science and technology, thus affecting residents' use of technology products.

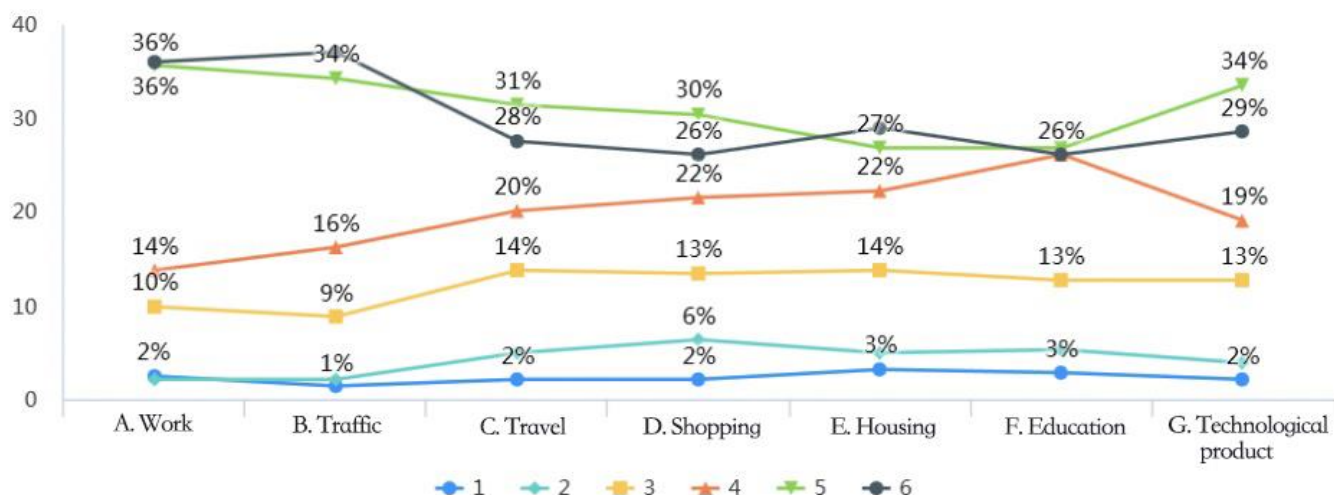

Figure 6: Analysis of the impact of regional collaborative innovation on life.

	N	Total	Average	Standard Deviation	variance
8.1	283	1376	4.86	1.211	1.467
8.2	283	1390	4.91	1.140	1.301
8.3	283	1292	4.57	1.277	1.630
8.4	283	1274	4.50	1.298	1.684
8.5	283	1278	4.52	1.338	1.790
8.6	283	1266	4.47	1.300	1.690
8.7	283	1313	4.64	1.245	1.550
Number of valid cases	283				

Figure 7: Descriptive statistical analysis of the impact of regional collaborative innovation development on life.

Regional construction will more or less cause certain problems. Here we investigate residents' attitudes towards possible problems. The results of the survey are shown in Figure 8. Residents believe that the most likely problem is uneven regional development, followed by corruption. Therefore, during the construction of the Greater Bay Area, the government should pay attention to the problem of uneven regional development. At the same time, the government should strengthen the supervision during the construction process, regulate and restrict the operation procedures of various projects, prevent corruption from occurring, and take certain punishment measures against illegal personnel.

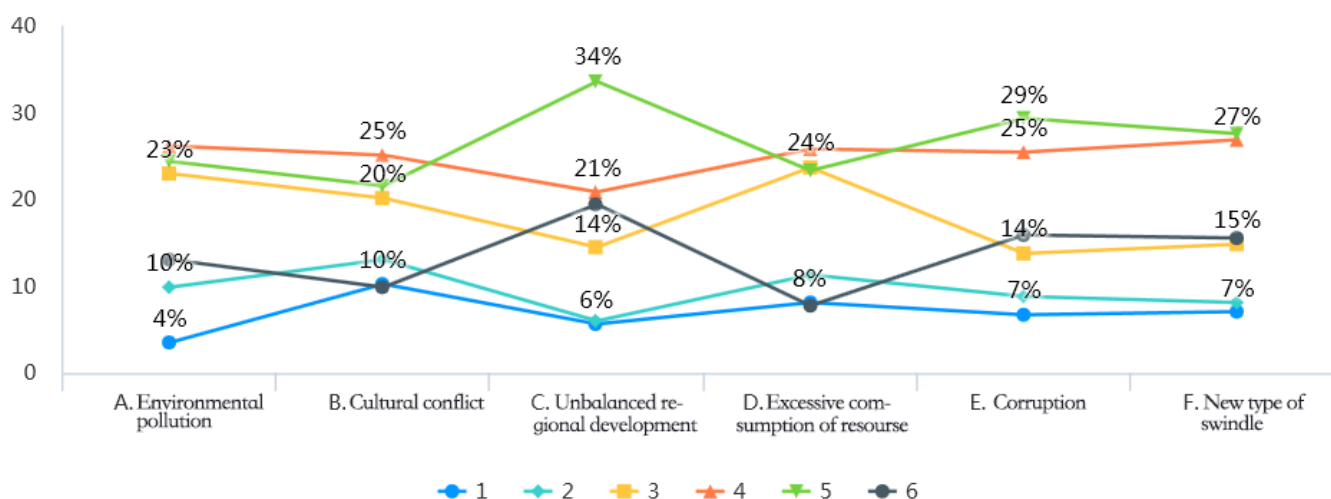

Figure 8: Analysis of possible problems in regional collaborative innovation development.

In addition, a question-and-answer question was set up at the end of the questionnaire for residents to fill in suggestions for collaborative innovation and development in the Greater Bay Area. The suggestions of comprehensive investigators mainly include the following:

- (1) Set up a broad framework for development and construction and unify policy guidelines.
- (2) Establish a working group involving Guangdong, Hong Kong and Macao to strengthen communication.
- (3) Stimulate corporate vitality and enhance corporate autonomy.
- (4) Strengthen talent exchanges and introduce domestic and overseas high-end talents.
- (5) Introduce advanced technology and strengthen intellectual property protection.
- (6) Strengthen regional communication, resource sharing and win-win cooperation.
- (7) Encourage regional entrepreneurial cooperation in the Greater Bay Area.
- (8) Pay attention to the cultural differences between Guangdong, Hong Kong and Macao, and make relevant coordination.
- (9) Strengthen the construction of local infrastructure such as medical care and education.
- (10) Pay attention to hygiene management and public security management in the development process.

CONCLUSIONS AND IMPLICATIONS

Conclusions

The construction of Guangdong-Hong Kong-Macao Greater Bay Area is of great significance. For China, it is not only a pilot area for China to deepen the achievements of reform in an all-round way, but also a key bay area for building a world-class international urban cluster. This study adopts two methods: case analysis and questionnaire. The case analysis method obtains the relevant development and construction experience by studying the existing cooperative innovation cases in the Greater Bay Area, while questionnaire method obtains residents' suggestions and preferences for the construction of Greater Bay Area. Combining the two methods, this study gives guidance for the development and construction of the Greater Bay Area based on the public opinion. This study still has some limitations. Some influencing factors and practical problems of regional collaborative innovation may not be fully examined. In terms of the questionnaire survey, most of the research samples are aged between 18 and 25. Also, most of the investigators are students, and with a junior college or bachelor degree or above. As the construction of the GBA is still in its early stage, in the future, in-depth research should be conducted to find out effective ways for the development of the Greater Bay Area.

Managerial Implications for Electronic Business

Collaborative innovation and development of the GBA is conducive to building an efficient cross-regional e-commerce platform, which will facilitate in-depth cooperation and resource exchange between regions, improve the efficiency of personnel flow and logistics as well.

Under the background of collaborative innovation and development of the GBA, small and medium-sized enterprises (SMEs) will benefit from the emergence of more innovative financing modes, especially the online modes. These innovative financing modes will also stimulate the enthusiasm and initiative of SMEs to participate in inter-regional e-commerce cooperation.

In terms of science and technology, collaborative innovation of the GBA will continuously promote the application and development of emerging technologies such as 5G and blockchain in e-commerce activities. In the process of developing new e-commerce modes, the coordination of the development of science and technology in the GBA will also be promoted.

With the jointly building of transportation in the GBA, geographically isolated areas can be effectively connected, providing necessary and convenient support for personnel flow and logistics between regions, and constantly improving the efficiency of cooperation and exchange.

Through the collaboration of education, the shared talent platform of the GBA could facilitate the allocation of senior talents in the enlarged human resource market, especially those in the service industry and universities from Hong Kong and Macao, which would help to flourish the development of advanced service industry in the GBA.

ACKNOWLEDGMENT

This work is partially supported by 2019 Guangdong Soft Science Project (2019A101002075), Guangdong Education Science Plan 2019 University Employment and Entrepreneurship Research Project (2019JKCY010).

REFERENCES

- [1] Central Committee of the Communist Party of China, State Council (2019). Outline Development Plan for the Guangdong-Hong Kong-Macao Greater Bay Area. Beijing, China. (In Chinese) https://www.bayarea.gov.hk/filemanager/sc/share/pdf/Outline_Development_Plan.pdf
- [2] Ho, R. (2006). *Multivariate Data Analysis and Interpretation with SPSS*, CRC Press, New York: Taylor & Francis Group.
- [3] ÓhUallacháin, B., & Kane, K. (2015). Regional aspects of collaborative invention across national innovation systems. *European Planning Studies*, 23(11), 2227-2252. doi: 10.1080/09654313.2014.942602
- [4] Peng, H.F. (2015). Comparative study on financial cooperation between The Pearl River Delta and The Yangtze River Delta. *Southern Finance*, 5, 79-82. <http://www.cqvip.com/qk/97901a/201205/42215211.html> (In Chinese)
- [5] Rubach, S. (2013). Collaborative regional innovation initiatives: a booster for local company innovation processes? *Systemic Practice and Action Research*, 26(1), 3-21.
- [6] Tucker, F. M. (2008). The rise of tech valley. *Economic Development Journal*, 7(4), 34-40.
- [7] Yan, B., Du, J., Pan, H. (2019). current situation, problems and countermeasures of technological collaborative innovation in the Pearl River Delta region. *Science and Technology Management Research*. 39 (1), 87-96. (In Chinese) <http://www.cnki.com.cn/Article/CJFDTOTAL-KJGL201901013.htm>
- [8] Zhang, G., & Wen, K. (2017). Collaborative innovation, regional integration and innovation performance: A comparative study on the data of China's three regions. *Science and Technology Progress and Countermeasures*. 34(5), 35-44. (in Chinese) <http://www.cnki.com.cn/Article/CJFDTOTAL-KJJB201705006.htm>
- [9] Zhao, L.L. (2011). Research on Industrial transformation and upgrading in the Pearl River Delta. *Academic Research*. 8, 71-75. (In Chinese) <http://www.cqvip.com/qk/94493x/201108/38919098.html>
- [10] Zhong, J.Y., & You Y.C. (2019). Research on the Mode and Path of Promoting the Deep integration of Guangdong, Hong Kong and Macao Greater Bay Area Collaborative Development. *Journal of Zunyi Normal University*. 21(5), 60-64. <https://ie.cnki.net/kcms/detail/detail.aspx?filename=ZYSF201905015&dbcode=XNYJ&dbname=XNYTLKCJFDLAST2019&v=> (in Chinese)

Research on Upgrading and Building of Public Technology Service Platform for SMES in Jiangsu Province under the Background of “Internet +”

(Full Paper)

Li Yao*, Nanjing Institute of Technology, Nanjing, China, yaoli@njit.edu.cn

Fujiang Ge, Nanjing Vocational College of Information Technology, Nanjing, China, gefj@njcit.cn

ABSTRACT

With the full popularization and rapid development of Internet technology, Jiangsu small and medium-sized enterprises are facing great opportunities and challenges. The public technical service platform for small and medium enterprises can effectively respond to the needs of small and medium-sized enterprises and strive for necessary government resources when conducting corporate guidance. At the same time, for government agencies, relying on the platform's appeal and social relations is conducive to the effective publicity and promotion of government policies, so upgrading the public technology service platform for SMEs is the key to connect the government and enterprises. This paper breaks through the description of traditional technology service platform confined to geographic space, extends the technology service function to the Internet area, and introduces the “Internet +” concept and platform agglomeration theory to the upgrading and construction of public technology service platform of Jiangsu small and medium-sized enterprises.

Keywords: Small and medium enterprises, public technology service platform, platform agglomeration.

*Corresponding author

INTRODUCTION

With the acceleration of technological progress and industrial upgrading, the survival and competitive environment of small and medium-sized enterprises has undergone fundamental changes. Promoting technological progress of small and medium-sized enterprises has become the key to enhancing the core competitiveness of small and medium-sized enterprises. The needs of small and medium-sized enterprises have built a huge market. In the face of this market, domestic and foreign products and service providers have launched software and hardware products for small and medium-sized enterprises in various aspects such as product design and development, production process, operation management, inspection, and testing. At the same time, through policy guidance and financial support, local governments have guided and built a series of public technical service platforms that serve the links of the enterprise value chain.

During our research on the Jiangsu public technical service platform, we found that the technical services provided by the current single professional technical service platform still have a certain gap with the growing needs of small and medium-sized enterprises, which limits the functions of the public technical service platform. It is unable to effectively connect the upstream and downstream industrial chains of SMEs, which also limits the scope of SMEs seeking business opportunities. Therefore, we break through the description of traditional technology service platform in the geographical space, extend the technology service function to the Internet area, and introduce the “Internet +” concept into the construction of public technology service platform Design. This paper proposes the upgrading of Jiangsu public technology service platform under the background of “Internet +”. It is the construction of the “Internet +” Jiangsu public technical service platform to create a new platform development ecology in a new field, so that the platform can reshape the structure and find a lasting development path. This is also an important measure to implement Jiangsu's innovation-driven strategy, enhance the competitiveness of Jiangsu's small and medium-sized enterprises and accelerate regional industrial upgrading

RESEARCH PATH

Based on theoretical research, we use the Jiangsu Province SME Information Promotion Project as a practical opportunity, relying on the public technical service platform for SMEs, and conduct practical exploration of platform clusters. Figure 1 shows the detailed research path of upgrading the public technology service platform for SMEs. The upgrading construction of the public technical service platform for small and medium-sized enterprises in Jiangsu includes three aspects: First, determine the concept of upgrading the public technical service platform under the Internet + background. Second, once a small and medium-sized enterprise puts forward a demand, the resource manager of the platform cluster will decompose the task, and select, match, and schedule the superior resources of each professional technical service platform in the entire cluster to provide services for customers. Integrate "Internet +" technology throughout the process to improve platform service efficiency (Cenamor, Parida & Wincent, 2019). Third, make use of the Internet area space to implement the upgrade and construction of a public technical service platform for small and medium enterprises in Jiangsu Province.

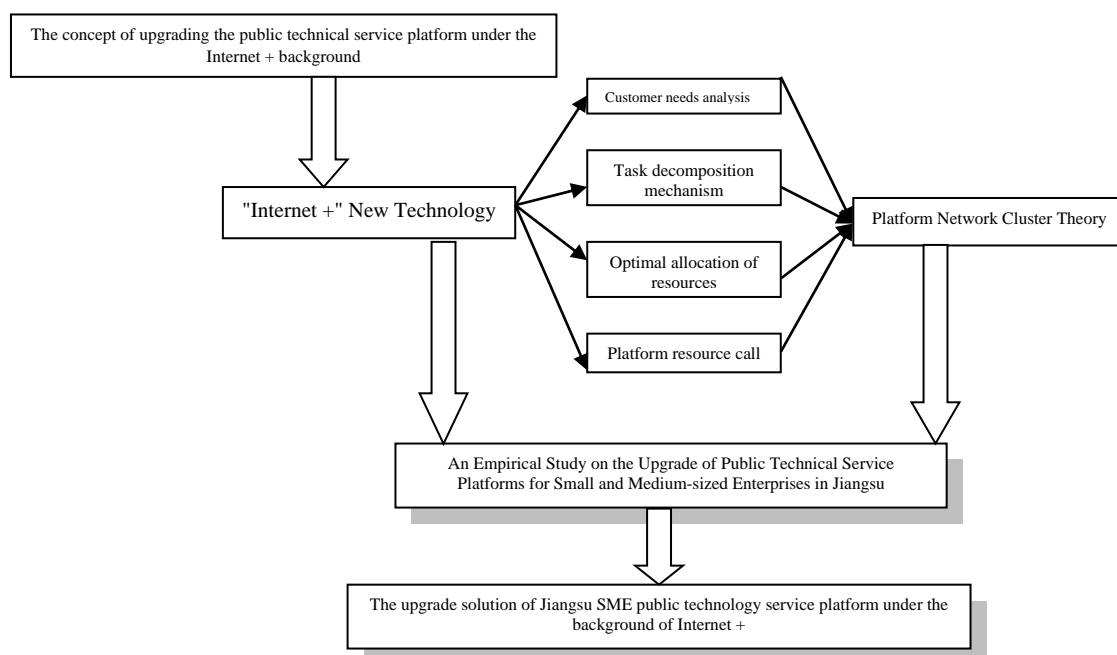

Source: This study.

Figure 1: research framework for upgrading public technology service platform of SMEs in Jiangsu under "Internet +" background

LITERATURE REVIEW

Research on Cluster

Marshall, a British classicist, put the concept of industrial zone forward. He called the specific area formed by many relevant specialized small and medium-sized enterprises in space as industrial zone. In 1978, Italian sociologist Bucatini believed that the new industrial zone is a social and regional production complex formed by people and enterprises with common social background in a certain natural region. Porter put forward the concept of "industrial cluster" in the economics of cluster and new competition, that is, the agglomeration of companies and institutions related to each other in a specific field on the geographical location.

The definition of industrial cluster by domestic scholars is similar in essence. Industrial cluster refers to the concentration of enterprises in the same industry, related industries and supporting industries in the geographical location. The cluster is composed of a group of small and medium-sized enterprises, which are independent of each other but have a specific relationship with each other. The cooperation-based interaction among enterprises within a group can produce external economy, which includes the formation of transaction relationship and mutual behavior adjustment among enterprises. The industrial cluster, as an intermediate institutional organization, is an enterprise network organization between the market and the customer level. Industrial cluster has the characteristics of systematisms and enterprise network (Dong, & Chen, 2008).

Based on the above theory, in the research process of public technology service platform for small and medium-sized enterprises, we found that the technical services provided by a single professional technical service platform could not connect the upstream and downstream industrial chain, which also limits the scope of small and medium-sized enterprises to seek business opportunities. Currently, the exchange and cooperation between professional technical service platforms is particularly important (Liu, & Tang, 2005). Therefore, we break through the description of industrial cluster theory limited to geographical space, expand the theory to the Internet regional space, and define the platform in economics. This paper puts forward the concept of "platform cluster". Through the study of public technology service platform clusters for small and medium-sized enterprises in Jiangsu Province, the establishment of public technology service platform clusters for small and medium-sized enterprises, so that platform services can achieve the effect of "1+1>2", help small and medium-sized enterprises to maximize corporate value and improve their competitiveness.

Research on the connotation of platform

At present, the research on platform is still in its infancy in China. In the manufacturing industry, it is considered that the platform is set up for the convenience of operation in the process of production and construction. In the IT industry, the platform is the operating environment of computer hardware or software. In the field of policy, in 2010, the Ministry of industry and information technology, the development and Reform Commission and other seven departments jointly issued the guiding opinions on promoting the construction of public technology service platform for small and medium-sized enterprises. According to the principle of openness and resource sharing, the service platform provides regional and industrial SMEs with

information inquiry, technological innovation, quality inspection, regulations and standards, management consultation and entrepreneurship assistance. Legal entity providing services such as guidance, market development, personnel training, equipment sharing, etc. According to the administrative measures of Jiangsu Province on public technology service platform for science and technology, the public technology service platform for science and technology is characterized by foundation, openness, and public welfare, which provides science and technology resources sharing services, public technology services, innovation, and entrepreneurship services to the society. Platform is essentially a trading space or place, which facilitates the transaction between two or more customers, and gains profits by charging appropriate fees.

Many scholars have discussed the concept of public technology service platform. It is generally focused on industrial parks and industrial agglomeration areas with certain industrial advantages. (Song *et al.*, 2013). It is characterized by professional technical services, and is a scientific and technological service institution with the mission of solving common technical problems that are necessary for the development of small and medium-sized enterprises and cannot be completed independently. It is a supporting system for providing technical services for industrial development. At the same time, some scholars have conducted research on the function of the platform, and believe that the function of the platform can be divided into three aspects. One is as a carrier for gathering scientific and technological elements, and the other is that it can unite multiple entities, such as universities, enterprises, and research institutes. Cooperation produces more innovative results; the third is to meet the needs of many enterprises (Yin *et al.*, 2011). The platform provides professional public services by gathering scientific and technological elements such as capital, technology, and talents, laying a solid technological foundation for industrial development and vigorously promoting industrial innovation.

Through preliminary research, we believe that the platform in the field of science and technology industry economy has the following characteristics: basic and shared, service, information technology, knowledge reuse and innovation, and value creation. In summary, the platform is an environmental entity that integrates industry knowledge accumulation and solutions, and is deployed by software and hardware such as computers, communications, networks, and other related intelligent technologies (Chai, Xiao, & Liu, 2018).

Research on platform cluster

Cluster is a concept widely used in spatial economics, location economics and geographical economics. Clusters usually represent the concentration of enterprises, and this concentration can produce synergy. A group of geographically close interconnected companies and related institutions, which are located in a specific industrial field, are linked by commonness or complementarity (Zhuang, & Chen, 2019).

Due to the limitation of capital, personnel, technology and other production factors, many small and medium-sized enterprises face technical problems in product R&D and design, production and manufacturing process, marketing and promotion, and operation management. SMEs are dependent on public technical service platforms much bigger than larger enterprises. The single public technology service platform is unable to solve the various problems faced by many small and medium-sized enterprises. Therefore, it is necessary for the public technology service platform to cluster the platforms in accordance with the requirements of the industrial chain or enterprise value chain to form a corresponding industrial chain or enterprise value chain. The public technical service chain to promote enterprises to carry out technological innovation in all links of the industrial chain, especially the value chain.

In recent years, the Internet has become an important technology carrier in the information age. It has resource advantages in specific fields and provides professional services to users with its own established resources. From the perspective of application scope, the unlimited nature of the Internet space can effectively support more and more users, and can respond quickly to users' different resource requirements, Application requirements and service quality requirements. From the perspective of application depth, the Internet is an information resource and the collection of resource sharing can satisfy users and efficiently provide a networked service system supporting product lifecycle management and dynamic alliances (Shen *et al.*, 2003).

According to Article 3 of the administrative measures of Jiangsu Province on public technology service platform for science and technology, the public technology service platform can be divided into network public technology service platform with multi units participating in the co construction or having multiple function sub platforms according to the composition mode. We can see that the network public technology service platform, as an important part of the construction plan of Jiangsu Province science and technology infrastructure, has on the agenda. In view of this, we propose the platform cluster research of public technology service based on Internet. In the network environment, all kinds of service platforms are combined to form a virtual organization of association and coupling. Many distributed resources are integrated through the joint and cooperation between platforms. An integrated resource environment is formed by taking the public technology service chain as the path to respond to the changing needs of users. The cluster is used to integrate the advantageous resources of each platform, which is small and medium-sized the development of enterprises provides powerful help.

ANALYSIS ON THE DEVELOPMENT AND OPERATION

Development of public technology service platform

Based on policy guidance, financial support and enterprise self-construction, the public technology service platform for small and medium-sized enterprises in the whole province has continuously enhanced its service function, improved its service mechanism, improved its service quality, and optimized its service layout, and made great achievements in its development.

(1) The province's public service network is formed. All 13 provincial cities and 49 counties (county-level cities) in the province have established service centers for SMEs. The coverage rate of SME service centers in cities and counties has reached 100%. With service centers for small and medium-sized enterprises at all levels as the leader, it integrates more than 2,000 intermediary service agencies and social organizations to provide a full range of services for small and medium-sized enterprises. The province has formed a small and medium-sized enterprise service network that is connected from top to bottom and linked at all levels

(2) Star service platforms are constantly emerging. At present, 7 public technology service platforms have won the national demonstration public technology service platforms, ranking first in China. Since 2010, the provincial star public technology service platform has been recognized. So far, there are 7 five-star public technology service platforms, 38 four-star public technology service platforms, 145 three-star public technology service platforms, and 80 one or two-star public technology service platforms. A multi-level, wide coverage and multi-functional public technology service platform network for small and medium-sized enterprises has been established, at the same time, it improves the innovation ability and product quality of small and medium-sized enterprises

Existing service base

At present, it has achieved initial results in the eight key service areas.

Entrepreneurship counseling

In recent years, Jiangsu province has focused on cultivating small business entrepreneurship bases, creating a public technical service platform for entrepreneurship counseling, and providing affordable entrepreneurial venues and thoughtful entrepreneurial services for the establishment and development of small and medium-sized enterprises in the province. At present, 280 provincial-level key cultivating small enterprise entrepreneurship bases. With the entrepreneurial base as the main carrier, a series of entrepreneurial counseling services have been launched.

(1) Launched the "Entrepreneurship Jiangsu" series of activities with the theme of "Entering the campus, entering the park, entering the countryside, entering the community";

(2) Launched the entrepreneurial base-experts "121 plan", organized entrepreneurial counseling experts to focus on cultivation in the province Small business entrepreneurship bases in China circulate to implement corporate diagnosis and counseling services;

(3) Implement the "annual scale cultivation project for thousands of micro-enterprises", establish an online management system for micro-enterprises cultivation, entrepreneurial QQ group and 400-0809-360 entrepreneurial consulting hotline to help micro-enterprises grow Conduct online tracking and consulting services;

(4) Hold private (small) and medium-sized business owner's management seminars to build a learning and communication platform for business owners to improve their capabilities and seek common development;

(5) Establish a team of entrepreneurial counseling experts to provide counseling for entrepreneurs and personnel Service;

(6) Compile "Entrepreneurship Guidance Manual" and distribute it to the public free.

Technical support

Relying on the characteristic industry cluster area, industrial park, and small enterprise start-up base, we will establish and cultivate a number of public technology service platforms for small and medium-sized enterprises. From a high starting point, we will build three provincial platforms for domestic technology transfer, international technology transfer and intellectual property trading of small and medium-sized enterprises in Jiangsu province. Up to now, more than 1/3 of 100 provincial key industrial clusters have established public technology service platforms, and more than 100 provincial key cultivation platforms and provincial demonstration platforms have been established.

Financing guarantee

One is to build a credit guarantee platform. By the end of 2018, there were 853 financing guarantee institutions in the financing guarantee industry of Jiangsu province, with the guaranteed balance of more than 280 billion yuan and serving more than 100000 enterprises. The business level and service quality of financing guarantee institutions have improved steadily, which has played an important role in alleviating the financing difficulties of small and medium-sized enterprises and promoting the healthy development of small and medium-sized enterprises. The second is to build a platform for bank enterprise cooperation. We have signed cooperation agreements to support the development of small and medium-sized enterprises with several financial institutions in the province, cooperated in the financing and cultivation of "ten thousand enterprises and hundreds of billion" small and medium-sized enterprises, and jointly held various kinds of small and medium-sized enterprises; financial products and services recommendation exhibition. The third is to build a financing service platform. We will open a financing service network for small and medium-sized enterprises in the whole province, provide a series of services such as online acceptance, reasonable docking, follow-up, and coordination, build a convenient bridge for enterprise financing, and build an online financing service platform. We will set up a pilot "financing supermarket", and cooperate with banks, guarantees and other relevant service institutions to provide comprehensive financing services to help small and medium-sized enterprises solve their financing problems. Fourth, broaden financing channels. We should strengthen the classified guidance of listed

reserve enterprises, organize intermediary agencies and experts to analyze and evaluate, scientifically arrange, and practically speed up the listing process of reserve enterprises. We will actively promote the issuance of pooled bonds, pooled short-term financing bonds and collective trust plans for SMEs, and help them to raise funds through multiple channels.

Personnel training

The province focuses on improving the management level, innovation ability and entrepreneurial ability of small and medium-sized enterprises. Relying on various educational resources, various forms of training such as degrees, academic qualifications, research and training, forums, and special lectures are carried out to improve the quality of small and medium-sized enterprises' talents. The enterprise cultivates a team of high-quality talents, establishes a training network covering the whole province that is supported and guided by the government, undertaken by local training institutions, actively assisted by colleges and universities, and actively participated by many small and medium-sized enterprises. Organize "Going Abroad and Outbound High-end Training Classes, EMBA Master Degree Classes, EMBA Successor Training Classes, MBA Classes, Leadership Improvement Classes for Outstanding Women, SME Main Management Training Classes, Experiential Training, Directors Advanced Classes, Competitiveness Lecture hall, "Ten Thousand Enterprises Upgrade" corporate president training class, investment and financing and capital operation advanced seminar, college student village official entrepreneurship training and other "top ten" types of training. Two corporate university platforms have been created. During the 13th Five-Year Plan period, it has grown to 10 and actively promoted the construction of internal training institutions for key enterprises.

Market development

Actively build domestic and international cooperation and exchange platforms to create opportunities and conditions for SMEs in the province to "go out" and "bring in" to carry out economic and trade cooperation and exchanges. Make full use of various exhibitions, expositions, trade fairs and other platforms to actively organize enterprises to participate in the China International SME Expo, Qingdao APEC Technology Exhibition and Exchange Conference, Hong Kong's "SME International "Market Promotion Day" Expo, "China International Small and Medium-sized Enterprises Fair and Equipment Industry Supporting Fair, Jiangsu Wuxi Private Enterprise High-tech Fair, guide and support the small and medium-sized enterprises in Jiangsu province to explore domestic and foreign markets.

Management consulting

Jiangsu province adheres to the principle of socialized and market-oriented management consulting services, guides social institutions to carry out public welfare management consulting services, and cultivates several management consulting service institutions with strong service ability and high service level. From time to time, organize management, finance, science, and technology experts to enter enterprises, and provide diagnosis, consultation and guidance on development strategy, organizational structure design, financial analysis, credit management, production management and other aspects for the development of small and medium-sized enterprises. Give full play to the advantages of colleges and universities and scientific research institutes, and provide diagnosis and consultation on management, market, technology, finance, and taxation according to the needs of small and medium-sized enterprises.

Information support

Focusing on the construction of three-level small and medium-sized enterprise network, we should establish and improve an open and convenient information service network for small and medium-sized enterprises. At the same time, relying on the network service platform, we will carry out e-government, e-commerce, market information release, online consultation, and other services. We will implement the project for small and medium-sized enterprises to guide them to carry out enterprise informatization construction. (Zhao, Wang, & Sun, 2004) "Jiangsu small and medium-sized enterprises e-commerce zone" was opened to display e-commerce cases of small and medium-sized enterprises.

Legal aid

The "96885" legal service hotline for small and medium-sized enterprises has been established and opened, integrating more than 100 law firms and more than 1000 professional lawyers from all over the province to provide 24-hour free legal consultation services for small and medium-sized enterprises in the whole province.

DEMAND ANALYSIS

Enterprise demand promotes platform upgrade and development

The public technical service platform for small and medium enterprises in Jiangsu Province is dominated by a single service platform. They focus on their core competitiveness and their services continue to develop in the direction of specialization. An interconnected network has not been established between platforms, and, collaborative services and resource sharing have not been realized, and it is difficult to form an overall social benefit. Each platform operates independently, the investment in human and financial resources is relatively scattered, and the scale and level are average. Although the platform has services, it is not easy for companies to find it, and it is difficult to form a service brand and gather platform popularity.

At present, public technology service platforms are mainly service centers for small and medium-sized enterprises at all levels. Most of them undertake part of the government's affairs. The administrative color is strong, and the ability to drive social service resources and sustainable development is insufficient. The core role needs to be strengthened, the individualized and

characteristic services provided by enterprises are insufficient, and the services are not well targeted.

Upgrading and development of policy incentive platform

In January 2017, the Ministry of Science and Technology issued the "Thirteenth Five-Year Special Plan for the Technological Development of the Indian Discovery Service Industry". On September 22, 2017, the Ministry of Industry and Information Technology announced the "Thirteenth Five-Year Plan for the Growth of SMEs". During the 13th Five-Year Plan period, the Chinese government will implement the network construction project of public technology service platforms for small and medium enterprises, support the construction and improvement of 4000 public service demonstration platforms for small and medium enterprises, and focus on cultivating 500 national public service demonstration platforms for small and medium enterprises, to promote various Social service agencies provide services for SMEs.

According to statistics from Jiangsu Economic and Information Technology Commission, as of February 2018, there were 109 public technology service platforms of various kinds in Nanjing, and 72 demonstration technology platforms and key cultivation technology platforms recognized by Jiangsu Province. The 72 provincial key technology platforms provide more than 100000 special technical services such as comprehensive technical services, inspection and testing every year, and more than 100000 enterprises have benefited. Technology service platform is the key to promote the transfer of manufacturing industry to the high end of industrial chain, to improve the benefit of products, and effectively drive the transformation and upgrading of manufacturing industry.

Jiangsu Province has formulated the "Jiangsu Province Science and technology public technology service platform management measures", the "Jiangsu Province National Economic and social development 13th five year plan outline" takes "promoting the construction of public technology support platform for small and medium-sized enterprises, establishing and improving technology transfer and transaction platform" as the strategic focus of innovation driven implementation in the 13th five year plan. To this end, the "three wings" of "Jiangsu Province" and "five wings" of "Jiangsu Province" have been put forward the service platform construction plan defines direction of upgrading and development for platform, and provides policy guarantee for platform upgrading and development. Jiangsu Province is facing unprecedented development opportunities for platform upgrading.

UPGRADING CONSTRUCTION MODEL

Construction objectives

In accordance with the basic idea of "integration, sharing, coordination, and improvement", with the policy of "government support platform construction, platform serving small and medium enterprises", focusing on resource integration, resource sharing as the core, and solving the service needs of small and medium enterprises as the main purpose. To build a small and medium-sized Jiangsu province with the provincial service platform as the hub and the window service platform of the provincial municipalities and industrial clusters in the province as the node. Information flow, resource sharing, service coordination, complete functions, wide coverage, convenient use, and continuous improvement of service efficiency the enterprise public technology service platform network has become the backbone of the province's SME service system.

Specific objectives: after the construction of the platform network, China Unicom will share no less than 2000 service resources and provide no less than 300 professional service functions. It will serve at least 150000 small and medium-sized enterprises every year, accept more than 100000 online and call services, and organize at least 300 service-docking activities every year the satisfaction rate of small enterprises is no less than 93%.

Overall structure

Jiangsu Province small and medium-sized enterprises public technology service platform network takes the provincial platform as the center, takes the window service as the support, coordinates the provinces advantageous service resources, realizes the interconnection and data resource sharing of the provincial service resources, and provides fast, high-quality, efficient, and sustainable services for small and medium-sized enterprises shown in figure 2. At the same time, the public technology service platform network reserves the data interface with the national small and medium-sized enterprise public technology service platform and other provincial platforms, to realize the high sharing of information resources with the national platform.

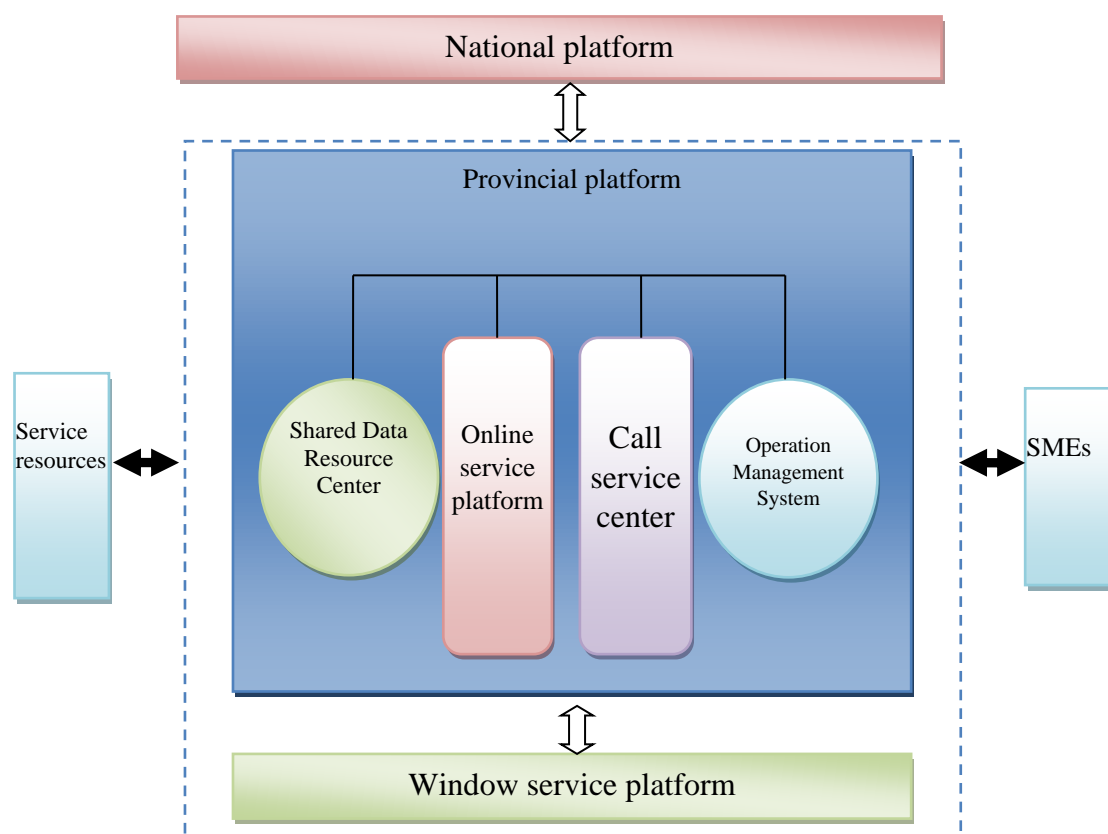

Source: This study.

Figure 2: The overall structure of the upgrade of the public technology service platform for small and medium-sized enterprises in Jiangsu

Jiangsu Province small and medium-sized enterprises public technology service platform agglomeration

Provincial platform

The provincial platform consists of "shared data resource center", "operation management system", "call service center" and "online service platform". Sharing data resource center realizes the unified storage and management of network service data resources of the provincial service platform, as well as the exchange and sharing of information resources of small and medium-sized enterprises in the whole province. Operation management system is the basic support platform for realizing the unified operation, hierarchical management, sharing use, efficient operation, and service coordination of public technology service platform of small and medium-sized enterprises in the province. Call service center use modern advanced communication network technology, computer technology and Internet technology to build a call service center with strong comprehensiveness, high stability, and good expansibility, and accept business consultation 24 hours a day. Online service platform consists of "application service center" and "public service portal". To provide one-stop network services and mobile terminal information services for small and medium-sized enterprises in Jiangsu Province, such as "e-government", "e-commerce", "financing guarantee", "video training", "technological innovation", "competitive intelligence", "consultation interaction", "recruitment and employment", "SaaS application", etc.

Window platform

13 provincial municipal windows and 50 provincial key industry cluster windows will be established in the province. First, based on regional considerations, a comprehensive service window platform with "SME Service Center" as the leader will be realized in the first batch of Unicom windows. Secondly, the small and medium-sized industrial enterprises above designated size in the province are mainly distributed in eight major industries, including machinery, light industry, petrochemical, textile, metallurgy, electronics, building materials, and medicine. From the analysis of the proportion of sales revenue, machinery accounted for 29.8% and light industry accounted for 13.5%, Petrochemical accounted for 14.6%, textiles accounted for 11.2%, metallurgy accounted for 9.9%, electronics accounted for 8.06%, building materials accounted for 4.9%, and pharmaceuticals accounted for 2.12%. In recent years, there have been some new changes in the industrial distribution of small and medium-sized enterprises. The traditional industries such as machinery, light industry, and textiles have gradually expanded to electronic information, equipment manufacturing, emerging industries, and modern service industries. Many small and medium-sized enterprises seized development opportunities and quickly occupied emerging markets. Based on professional considerations, 50 professional service window platforms that conform to the province's regional and industrial planning and layout have been established in the province's key industrial clusters. The first batch of locations: information, software, environmental protection, panels, photovoltaics, medicine, textiles, industrial design, 13 industrial clusters including energy conservation and environmental protection, glasses, home textiles, software outsourcing, and reducers; in the next two years: cutting tools, molds, electronic materials, crystals, ships, petroleum machinery, auto and motorcycle accessories, wind power, electric vehicles,

cables, new materials , Environmental protection equipment, engineering machinery, stainless steel, biopharmaceuticals, wind power, sensors, winemaking and other industrial clusters. As shown in figure 3.

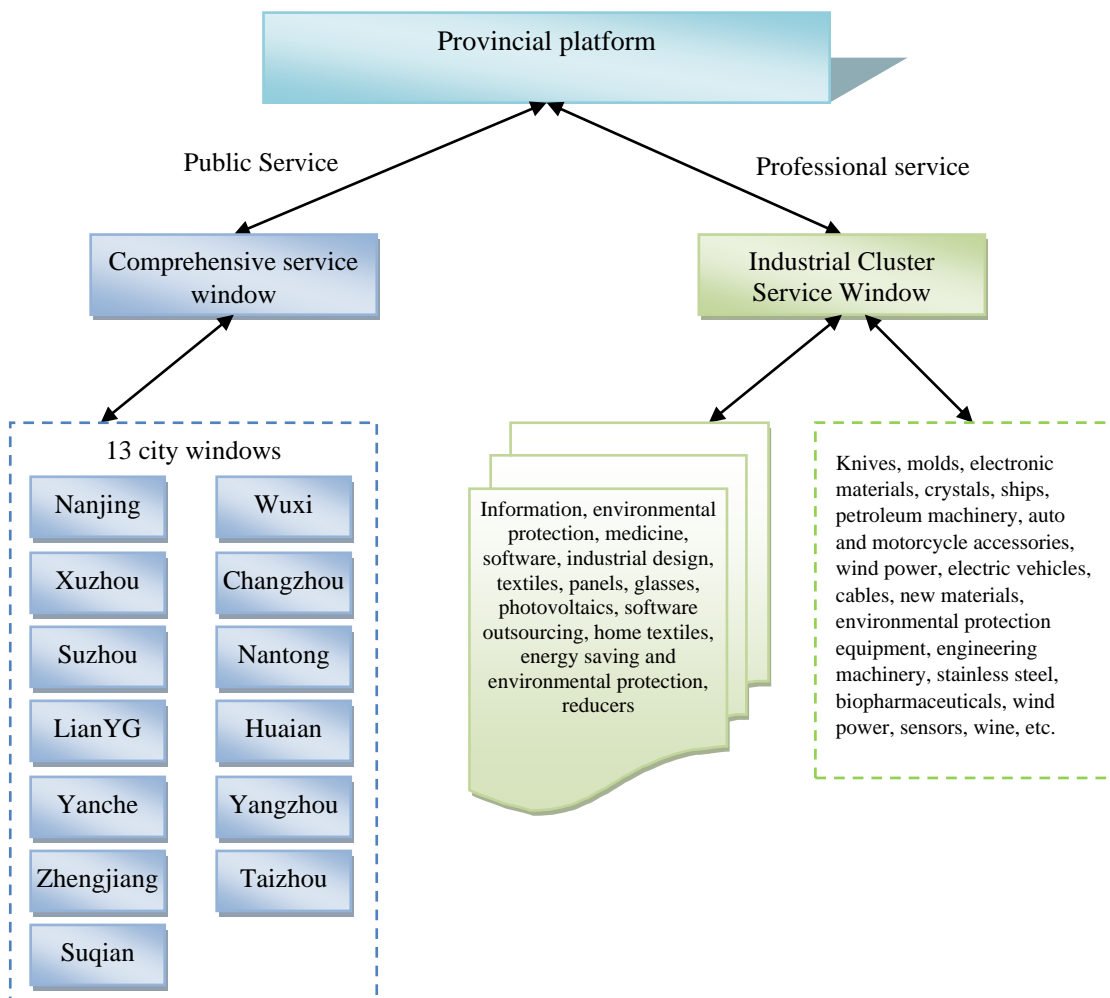

Source: This study.

Figure 3: Cluster planning diagram of public technology service platform for small and medium enterprises in Jiangsu Province

Platform upgrade and construction tasks

Establish a unified service brand

The whole service platform network is a complete organism, with a unified identification, unified management and support system, a unified service search, registration, and identity verification entrance, forming a unified service brand with consistent goals, services, and resources. First, based on Jiangsu small and medium-sized enterprise information network, the service portal and function are transformed to meet the requirements of service platform network. Secondly, the floating window with unified logo, web page style and function is applied to the website of each window service platform and the service resource website of service platform network integration. The floating window has the functions of "service search", "user login", "and supply and demand information release". Through the floating window, users can share data to the whole network platform can also enter the unified interface of provincial platform. The unified floating window is not only an important way for users to contact the service platform network, but also an effective way to publicize the service platform network.

Establish a set of automatic resource matching system

Realize the automatic service navigation in the online service, and truly achieve the "one touch service". One of the core functions of the whole service platform network is to facilitate the effective docking between service demanders and service providers. The public technology service platform network of Jiangsu Province will fully study the demand and supply of services, and realize the fully automatic, accurate and effective service information matching function (Chen, Wang, & Sun, 2011).It will provide screened and processed retrieval results for the users of small and medium-sized enterprises who need to find service institutions and the institutions that need to find service objects, so as to realize the intelligent matching between service supply and demand It can greatly improve the efficiency of service docking, establish the good practicability of service platform network, and bring great convenience to users.

Establish a set of perfect operation management system

The operation and management of the whole service platform network involves the construction unit, provincial platform, window platform, social service resources and many other aspects. It is necessary to study and formulate a series of work

processes, services or work agreements, quality management indicators, evaluation and assessment standards, data standards, technical standards, as well as corresponding expert groups, archives, inspection, and supervision institutions, etc. Sustainable operation of the system. (Chai *et al.*, 2018). These systems can guide, regulate, and restrict the activities of all levels of window service platforms, all kinds of small and medium-sized enterprise service institutions, cooperation units and so on, so as to ensure that the whole service platform network can smoothly achieve the goals of resource coordination, functional complementarity, information sharing and service collaboration. Through the scientific and perfect system construction, the system with Jiangsu characteristics, covering various service management functions, concise and effective, and strong enforceability is finally formed.

Establish a set of unified data specification

The construction and operation of the whole service platform network not only needs to complete the development and integration of many software and hardware functional modules, but also needs to ensure the stable and smooth communication of information. This requires great determination and energy in the research, discussion, and establishment of data specifications. Only when scientific and efficient standards are set up in this aspect, the unified linkage and resource integration of the whole service desk network will have a solid foundation. This work will include the establishment of data collection standards, data conversion standards, data sharing and exchange protocols, data retrieval, data mining and analysis, data modification and release, etc. (Chen, & Sun, 2011). Based on extensive investigation of the existing data platform, we will listen to the opinions of the construction unit, cooperation unit, window platform and advisory expert group to conduct scientific design and review.

Establish a stable and efficient technology platform

The service platform network takes the operation management system and shared data resource center as the core. Through the provincial platform, window platform, call center, mobile platform and other service portals, the service platform network can seamlessly link with many small and medium-sized enterprises, service institutions, government departments and other users. Through the core technologies such as cloud storage, database middleware, web application, SaaS application, 3G Application, etc., it serves the whole system the platform network provides stable and efficient data interconnection services, resource call response, service scheduling guidance, network technical support, etc. (de Reuver, Sørensen & Basole, 2018). on the one hand, it ensures that the data structure transformation of each window platform conforms to the specification of interconnection, on the other hand, it reduces the excessive investment in network technology and software development of each window platform, which saves investment, promotes service, and adapts to the platform the role of network expansion requirements.

Establish several window platforms with perfect functions and reasonable layout

First, scientific planning and reasonable layout should be carried out for the window service platform in Jiangsu province. The distribution of window platform should not only consider the geographical location of southern, central and Northern Jiangsu, but also consider the key industries, key industries, and emerging industries of Jiangsu province. At the same time, we should standardize and guide the construction units that are ready to be absorbed into the window, unify management and collaborative services, (Liu & Yan, 2008).and complete the layout of window platform in Jiangsu province as soon as possible.

CONCLUSION

This article introduces the concept of "Internet +" and the theory of platform clusters into the field of public technology service platforms, and upgrades the construction of public technology service platforms for small and medium enterprises in Jiangsu, and builds a cluster of public technology service platforms for small and medium enterprises in Jiangsu under the background of "Internet +". Platform development ecology. The upgraded platform cluster integrates idle resources and superior resources of network public technical services, connects the upstream and downstream industrial chains, expands the scope of SMEs to find business opportunities, and quickly responds to complex and changeable resource needs and application requirements of SMEs. The upgraded platform cluster can meet the development needs of SMEs in many aspects such as financing channels, product design, research and development, manufacturing, marketing, and promotion. The research of this paper extends the technical service function to the Internet field, breaks through the limitations of the traditional technical service platform, and provides an effective way for the sustainable development of the public technical service platform of Jiangsu SMEs.

ACKNOWLEDGMENT

This work was financially supported by research project of Jiangsu Provincial Department of Education University Philosophy and social science 2017: Research on the upgrading of public technology service platform for small and medium-sized enterprises in Jiangsu Province under the background of "Internet +" era (2017SJB0402), China.

REFERENCES

- [1] Cenamor, J., Parida, V., & Wincent, J. (2019). How entrepreneurial SMEs compete through digital platforms: The roles of digital platform capability, network capability and ambidexterity. *Journal of Business Research*, 100, 196-206. doi: 10.1016/j.jbusres.2019.03.035.
- [2] Chai, Y.T., Sun, B., Zhang, A., Liu, H., & Chao, Y.U. (2018). E-commerce market operation monitoring service platform. *Journal of Tsinghua University (Science & Technology)*, 58(9),796-801. doi: 10.16511/j.cnki.qhdxxb.2018.25.035 (in Chinese).

- [3] Chai, Y.T., Xiao, Y.U., & Liu, Z. (2018). Design and implement of a public service platform for e-commerce credible transaction guarantee. *Journal of Tsinghua University (Science & Technology)*, 58(9),802-807,820. doi: 10.16511/j.cnki.qhdxxb.2018.22.039 (in Chinese).
- [4] Chen, J. & Sun, L.F. (2011). Solutions of data security for industrial chain collaboration public service platform based on SaaS. *Computer Integrated Manufacturing Systems*, 17(6), 1317-1324. doi: 10.13196/j.cims.2011.06.199.chenj.022 (in Chinese).
- [5] Chen, J., Wang, S.Y., & Sun, L.F. (2011). Flexible model and architecture of public service platform for business-related multi-industrial chain collaboration. *Computer Integrated Manufacturing Systems*, 17(1), 177-185. doi: 10.13196/j.cims.2011.01.179.chenj.018 (in Chinese).
- [6] de Reuver, M., Sørensen, C., & Basole, R. C. (2018). The digital platform: a research agenda. *Journal of Information Technology*, 33(2), 124-135. doi: org/10.1057/ s41265-016-0033-3
- [7] Dong, Y., & Chen, J.X. (2008). Levels and Fractals of Industrial Cluster Complex Adapt System. *Journal of Shanghai Jiaotong University*, 42(11), 1862-1865. doi: 10.16183/j.cnki.jsjtu.2008.11.024 (in Chinese).
- [8] Liu, H.P., & Tang, M. (2005). Analysis of application of information in mid-mini enterprises on condition of mass-economy. *Journal of Chongqing Jianshu University*, 27(3), 116-119. https://xueshu.baidu.com/usercenter/paper/show?paperid=53376c679953263b63ca5765d5cf49d4&site=xueshu_se
- [9] Liu, M., & Yan, J. (2008). SOA-based business collaboration service platform for cross-enterprise and relative technologies. *Computer Integrated Manufacturing Systems*,14(2), 306-314. doi: 10.13196/j.cims.2008.02.100.lium.013 (in Chinese).
- [10] Shen, D.R, Yu, G., Song, B.Y., Wang, D., Dong, X.M, & Wang, G.R. (2003). An Enabling System for Small-Medium Enterprise Dynamic Alliances. *Computer Integrated Manufacturing Systems*, 9(1), 52-56. doi: 10.13196/j.cims.2003.01.52.shendr.011 (in Chinese).
- [11] Song, T.X., Zhang, C.L., Li, C.H., & Huang, B.Q. (2013). Cloud manufacturing service platform for small and medium enterprises. *Computer Integrated Manufacturing Systems*, ,19(5), 1147-1154. doi: 10.13196/j.cims.2013.05.253.songtx.017 (in Chinese).
- [12] Yin, C., Huang, B.Q., Liu, F., Wen L.J., Wang, Z.K., Li, X.D., Yang, S.P., Ye, D., & Liu, X.H. (2011). Common key technology system of cloud manufacturing service platform for small and medium enterprises. *Computer Integrated Manufacturing Systems*, 17(3), 495-503. doi: 10.13196/j.cims.2011.03.49.yinch.009. (in Chinese).
- [13] Zhao, H.J., Wang, S.Y., & Sun, L.F. (2004). ASP Platform for information system construction of medium and small enterprises. *Computer Integrated Manufacturing Systems*, 10(11), 1441-1445. doi: 10.13196/j.cims.2004.11.123.zhaohj.021 (in Chinese).
- [14] Zhuang, CY, & Chen, G.H. (2019). Decision making analysis of collaborative knowledge creation in industrial cluster innovation network considering knowledge spillover. *Control and Decision*, 34(7), 1521-1528. doi: 10.13195/j.kzyjc.2017.1759 (in Chinese).

Research on Users' Perceived Beliefs from the Perspective of Review Components

(Full Paper)

Qiong Jia*, Hohai University, Nanjing, China, jiaqionghit@163.com
 Huizhou Jiao*, Hohai University, Nanjing, China, 864277136@qq.com
 Yuxuan Li, Hohai University, Nanjing, China, 1433635381@qq.com

ABSTRACT

In the Internet era, how the review system brings user good experiences and influences users' perceived beliefs has become an important issue. Based on word-of-mouth and user perception theory, this article builds the model between four characteristics of the review components (integrity, intelligent extraction, operability and social interaction) and four types of users' perceived beliefs (perceived usefulness, reliability, convenience and pleasure). Also, this study makes analysis of 101 questionnaires, which shows that integrity, intelligent extraction has a positive influence on perceived usefulness; intelligent extraction and operability have a positive influence on perceived convenience; operability and social interaction have a positive influence on perceived pleasure; and social interaction has a positive influence on perceived reliability. According to these research results, user awareness and the performance of review components can be improved through measures to meet users' demand in practice.

Keywords: Review component, users' perception, word-of-mouth theory

*Corresponding author

INTRODUCTION

With the development of the digital economy, it has been popular for users to browse, use, or purchase online platform products. According to a report by Forrester, China's online system will be expected to reach USD1.8 trillion in 2022 with the development of online platforms like Taobao.com and JD.com. In addition to the large scale of online platforms, the number of online shoppers in China is also expected to grow from 460 million in 2016 to 660 million users in 2020 (Erickson, 2019). Compared to US consumers, just 25% of which were considered as "the most demanding, advancing, and innovation-hungry digital shoppers", Chinese consumers were found with 72% ranked as "Progressive Pioneers" (Long, 2018).

Users' perceived beliefs lead to decision-making behaviors. The composition of different types of review systems, which means an integral part consisting of different sections and the content on the network platform, also affects users' perception in different ways, as shown in Figure 1. For example, the missing design of the screening components of the review systems may lead to user's fatigued reading and influence user's decision-making (Sun, Zheng & Chen, 2020). What's more, with the advancement of online interactive technology, the review component also serves as a user-experiencing-platform and a communication bridge thus making the following decisions more rational (Jiang, 2020). Under such conditions, how each part of the functions in review components meets users' needs and brings them a convenient experience is the important factor that affects users to choose websites for purchase behavior and social activities.

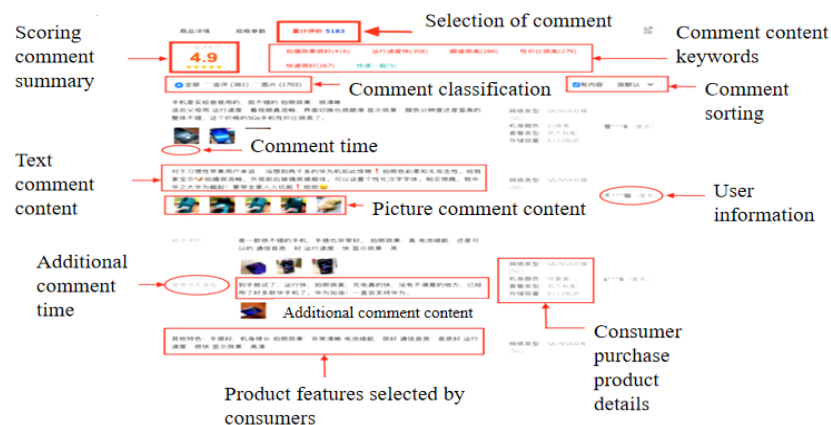

Figure 1: The review component on Taobao.com

However, most previous studies concerning the review components and users' perception focused on few parts of review components instead of an integrated perspective according to "Classification of mobile commerce and research review of user adoption behavior" (Li, 2020). In terms of users' perception, it only involves the analysis of part of the users' behavior according to "Consumer Trust, Value, and Loyalty in Relational Exchanges" (Sirdeshmukh, Singh & Sabol, 2002). So there exists a research gap to look at the strategic potential of a novel model - the relationship between review component and users' perception to providing theoretical and practical guidance for the platform to improve the existing review component system.

Hence, this article will systematically analyze the various parts of the review components in different types of websites and map the relationship between these components and users' perceptions. Also, it will analyze and allocate different kinds of perceptions on corresponding components when they use website platforms. In terms of practical significance, it will study the relationships between review components and users' perceptions from the perspective of the website platforms. From the review components' point of view, it will enable the website to update the existing review component, thereby improving the efficiency of the website. From the users' point of view, it can help users quickly and effectively make references and decisions for better user experience. Briefly, the main issues discussed in this paper will focus on how the characteristics of the review components perceived in different types of websites will affect users' perception beliefs, and different component characteristics will bring users what kind of perceptions. The remainder of this paper is organized into five sections namely literature review, model construction and hypotheses, methodology, discussion, and conclusion as follows.

LITERATURE REVIEW

Online Review Components

Table 1 is an overview of previous research involving the review components. Most of the existing research on review components focuses on the impact of the content of the review or the positive or negative attributes to consumers' purchase intention according to "An empirical study on the influence of online reviews on consumer purchase intentions." (Song & Tang, 2020) and "Research on the effect of online reviews' presentation order on consumers' purchase intentions." (Li et al., 2020). Also, some have conducted empirical researches on the presentation of reviews and concluded corresponding conclusions based on "Research on the impact of online reviews on five-star hotel spending intentions" (Jiang, 2020). However, none of them systematically involves the connection between review components and users' perceptions, and there is no article expounding the corresponding influence relationship between two of them.

Table 1: Overview of research related to online review components

Author (published time)	Research topic	Research method	Conclusion
Song & Tang (2020)	An empirical study on the influence of online reviews on consumer purchase intentions.	Through eye-tracking experiments to explore the influence of online reviews on consumer purchase decisions.	Individuals' processing of attribute review information is longer than that of experience reviews, and it takes more cognitive effort. However, consumers' willingness to buy is even smaller.
Li et al. (2020)	Research on the effect of online reviews' presentation order on consumers' purchase intentions.	Conduct empirical research and use SPSS 21.0 to process the data.	The online reviews' presentation order influence consumers' purchase intentions by influencing consumer attitudes.
Jiang (2020)	Research on the impact of online reviews on five-star hotel spending intentions.	Quasi-experimental methods	Negative reviews have a more significant impact on consumer spending intentions than positive reviews, the impact of review scores on spending intentions is in an important position.

User perception Belief

From the perspective of users' perception, most current studies link the content or the nature of reviews to their users' influence. It can be concluded from previous studies that the content of reviews is one of the core factors of consumer perception.

Table 2: Overview of research related to user perception belief

Author (published time)	Research topic	Research method	Conclusion
Sun, Zheng, Chen (2020)	Research on the impact of perceived online review credibility on consumer trust - the moderating effect of uncertainty avoidance	Questionnaire design and sample research	The objectivity of platforms, the professionalism of reviewers, and the quality of reviews positively affect the credibility of online reviews perceived by consumers; the perceived credibility of online reviews positively affects consumers' ability, trust, and goodwill in businesses trust; uncertainty avoidance mediates the relationship between platform objectivity, the professionalism of reviewers, and perceived credibility of online reviews.
Tan (2019)	Research on online group purchase consumers' buying behavior based on customer perceived value	Empirical research	The three dimensions of perceived quality, perceived price benefits, and perceived convenience will all have a positive impact on group buying consumers' purchasing decisions; and perceived risk is negatively correlated with consumers' online group buying decisions.

The Relationship between Review Components and Users' Perceived Beliefs

As a module provided by the website for users to browse and use, the review component plays the role of constructing a platform for interconnection between users and websites. Users' perception belief is the user experience during and after using the online review component, and there is a certain mutual relationship between two of them. Different types of review components on the website have different effects on users' perceptions. After preliminary generalization, the most representative features of the four types of review components which have impact on users' perceptions are integrity, intelligent extraction, operability, and social interaction. Different types of review components also have different characteristics. These components can bring different perceptions to users because they have the above characteristics.

However, the existing literature has two main deficiencies. On the one hand, there is no mention of the impact of review components on users' perceptions. On the other hand, users' perception only focuses on perceived value. Therefore, this research will analyze what impact the characteristics of review components will make users aware of, and how review components will make users feel. Drawing lessons from previous studies on network platform services and users' perceived value, and combining the functions of the website review components and the concept of users' perception beliefs, this research divides the characteristics of review components into integrity, intelligent extraction, operability, and social interaction, considering perceived usefulness, perceived reliability, perceived convenience, and perceived social interaction of users' perception.

The characteristic of review component system is integrity. As can be seen from Figure 1, the review component of Taobao.com includes a scoring review component, a keyword extraction component, a review classification component, a review ranking component, a user information component, and a review content component. These review components serve functions like viewing product ratings, browsing reviews, and selecting intent reviews for browsing, which can meet the needs of users who want to learn from past consumer reviews to make their purchase decisions more rational, indicating the completeness of the entire component system. If the review component is not complete, it may not meet the users' needs, which means that the integrity of the review component may affect the usefulness perceived by users. The characteristic of review content component is intelligent extraction; it is the fastest channel for users to find their intended product reviews. This review component extracts specific words, eliminates the trouble for users to repeatedly browse during the browsing process. It can help users save time and facilitate users' use process, and it can be inferred that intelligent extraction may affect the users' perceptions of whether review components are convenient. The characteristic of the scoring review component is operability. The scoring review component is the most intuitive among all components, and can directly reflect the evaluation of the product in the past by consumers, so this component can enable consumers to make the fastest decision about whether you want to continue browsing the review. It can be seen that the operability of the review component may have an impact on the ease of use perceived by the user. Therefore, it reveals that the characteristics of review components provided by network platforms will have different effects on users' perceived beliefs. The relationship between specific review components and users' perception will be further hypothesized and verified in the following empirical research.

Related Theories

Word-of-mouth Theory

Hennig-Thurau et al. (2004) pointed out that online word-of-mouth is that consumers share their own experience, opinions, and related knowledge of consumer products or services with other consumers through online channels. From the perspective of shopping platforms, online word-of-mouth refers to the process by which consumers share information about products and services

through the Internet after purchasing products. It is a form of consumer experience exchange between consumers, mainly in text, pictures, and videos presented in Figure 2.

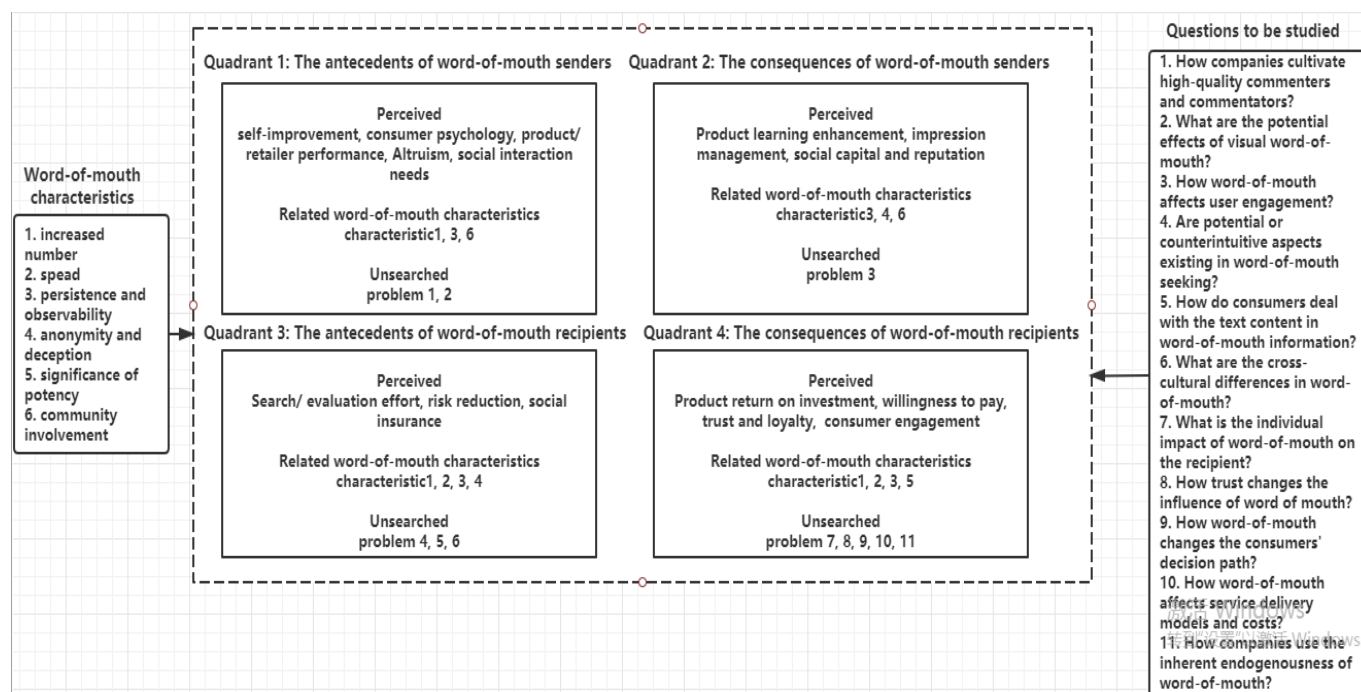

Figure 2: Online Platforms Based on Word-of-Mouth Theory in Marketing

In the process of reviewing the literature, previous researchers believe that the main reasons that prompt users to pay attention to word-of-mouth include: (1) saving time in the evaluation work and search process before purchase; (2) reducing the possibility of making mistakes when shopping; (3) seek psychological protection and comfort; (4) possible negative psychology (Figure 2 third quadrant). Moreover, different types of websites will provide consumers with different types of perceptions about word-of-mouth so that consumers will have corresponding differences behaviors when they use review components.

User Perception Theory

In the research on the composition of users' perception, Sheth et al. (1991) found that five types of values affect the consumer's purchasing behavior, namely functional value, cognitive value, social value, contextual value, and emotional value. Also, Cheung (2009) believed that the credibility of online reviews refers to website users' perception of the reliability or authenticity of reviews on online platforms. This perception is not limited to shopping websites, it also has the same effect on other types of websites in the passage. According to Sun (2020), the objectivity, the quality of review contents, and the professionalism of reviewers will positively affect consumers' perception of the credibility of online reviews; and the credibility of online reviews will positively affect consumers' ability trust, honesty trust and good faith trust in the platform; uncertainty will evade the mediation of the relationship between the objectivity of review content, the professionalism of reviewers and the perceived credibility. This conclusion explains how the information provided by the platform affect the users' perception and perceptual attributes, and further explains the multidimensional and personalized characteristics of perception.

In summary, based on the literature, we can find that users' perceptions of review components come from the website itself, and the website itself also provides users with information about services, and affects the users' experience during use. Hence, there is a close relationship between two of the factors. The website affects the user's perception so that users have a different experience in the process of using different websites and components provided by the website; the users' perception also functions with the website platform so that the platform can improve and adjust its components according to user' feedback after use.

Characteristics of Different Review Component System

From the classification of the review components and the functions they provide in the previous article, the characteristics of the components can be divided into four categories in our study: integrity, intelligent extraction, operability, and social interaction. These four types of characteristics describe how the review component affects users' perception. Table 3 is a detailed description of the characteristics of the review component and the judgment criteria.

Table 3: Review systems: characteristics and concepts

Characteristics	Definition
Integrity	The degree of user's feeling about the integrity of review components.
Intelligent extraction	The degree of user's feeling about whether review components is timely and conforms to the current user habits.
Operability	The degree of user's feeling about whether they have a convenient using experience on review components and whether they can quickly and accurately complete the operations they want.
Social interaction	The degree of user's feeling about whether the website can meet users' needs to communicate with others in the process of using review components.

MODEL CONSTRUCTION AND RESEARCH HYPOTHESES

Model

Online review component and users' perception model

The following icons show the relationships between the features of components and users' perception:

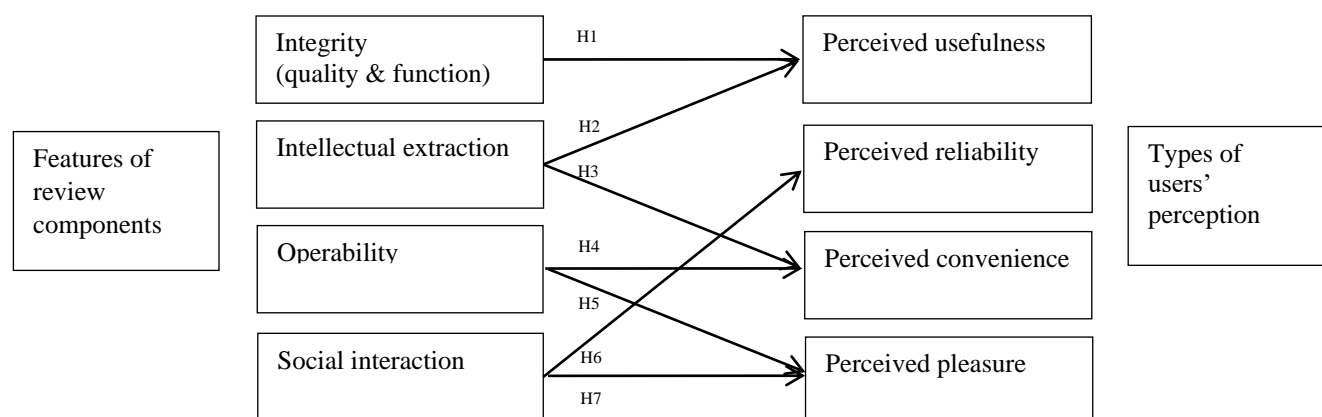

Figure 3: The relationship between users' perception and review components

Research Hypotheses

Wood & Scheer (2006) believed that users' perception is a trade-off between perceived benefit and perceived risk. Perceived risk is the main perceived cost (including time, energy, and money) that users spend on the platform, which has a significant impact on users' perceived usefulness, perceived reliability, perceived convenience, and perceived pleasure. Based on the above point of view, this study believes that the characteristics of the four components proposed in Figure 3 will have a positive impact on the four types of perception. Research hypotheses are 1-7, which are as follows:

- H1: The integrity of the review component (quality and function) has a positive influence on the perceived usefulness; When reviewing the literature, integrity refers to the degree of user's feeling about the integrity of review components. The more content users adopt, the higher the perceived usefulness, and the relationship between them is positively correlated. Therefore, the analysis of perceived usefulness should focus on whether the characteristics of the review component can improve the users' acceptance of the content provided in the component. When the review component can display enough information to the user, the user can make their judgments and make decisions based on the obtained information. In this case, the users' acceptance of the content provided in the component will increase. At this time, the usefulness perceived by the user will become more prominent. Therefore, we can derive the relationship between the integrity of the component and the perceived usefulness based on this connection: the more significant the integrity of the review component, the more perceived usefulness will be.
- H2: The intelligent extraction of the review component has a positive influence on the perceived usefulness;
- H3: The intelligent extraction of the review component has a positive influence on the perceived convenience; The users' acceptance of the content provided in the component will not change due to the slow update of the component as they make decisions after obtaining the existing information. Also, the component iteration has no effect on the user's acceptance so that there is no direct connection between intelligent extraction and user perceived usefulness. When judging the user perceived convenience, the core of attention is whether the component can meet the users' desire to save time and unnecessary costs through the component. This standard is related to the degree of user's feeling about whether review components is timely and conforms to the current user habits, and it can be concluded that: the convenience perceived by users has a corresponding relationship, and there is a positive correlation between two of them.

- H4: The operability of the review component has a positive influence on the perceived convenience;
- H5: The operability of the review component has a positive influence on the perceived pleasure;

According to the previous analysis, the operability of the review component is related to the degree of user's feeling about whether they have a convenient using experience on review components and whether they can quickly and accurately complete the operations they want. The more obvious the operability of the component, the lower time-cost of the users spent in the process of use, and the required effort will be reduced accordingly. From the description of these characteristics of the component, it can be concluded that the operability will affect the users' perception of convenience. Since the criterion for operability does not involve the adoption of review components and the process of helping users make decisions and enjoying using components. Based on this, it can be judged that the operability of the review component only affects the perceived convenience, and the more obvious the operability of the component, the more obvious the perceived convenience will be. Hence there is a positive correlation between the two of them.

- H6: The social interaction of the review component has a positive influence on the perceived reliability;
- H7: The social interaction of the review component has a positive influence on the perceived pleasure;

The social interaction of components reflected that the website can provide users with a platform for expressing their opinions and communicating with others. In the research on shopping websites, the platform that provides user feedback components can show that it has social interaction, and the existing component is intended to enable users to obtain more information by communicating with consumers and helping consumers make rational shopping decisions. This concept of characteristic can be explained whether the social interaction of component will affect the perceived reliability. Due to the characteristics of the video website itself, the review component is the core of the operability. The main needs of users are to use components to express opinions and discussions, so review components also emphasize social interaction. The purpose of users' expressing opinions is to gain a sense of identity or to improve their opinions by communicating with other users. In this process, users' perceived pleasure is highly significant.

In conclusion, based on the relevant research hypotheses proposed above, this questionnaire survey sets the characteristics of the review component as an independent variable, and the users' perception as a dependent variable. The model is shown in Figure 3.

METHODOLOGY

To collect practical data, this research designs a questionnaire to explore the connection between review components and users' perceptions. The questionnaire starts from the user's point of view, uses the review components provided on different types of websites as independent variables, users' perceptions of review components as dependent variables, users who fill in the questionnaire as the subjects. The questions involved in the questionnaire will revolve around the user experience and feelings in the process of using the review component.

Measurement

Perceptions refers to the impacts of the user when using the review component. Feelings are generated by users during and after using review components. In this article, perceptions are used to detect the impact of the users' measurement review component, and the feelings are used to measure the users' perceptual beliefs. The specific scale is as follows:

Table 4: Measurement items

Variable	Sources	Questions
DC: Perceived integrity	Huang & Hsieh (2011)	DC1: I perceive that the frequently used website components are fully functional. DC2: I noticed that the review component is not missing when using it. DC3: I perceive that what I want to know can be found through components.
DI: Perceived intelligent extraction	Novak et al. (2000)	DI1: I noticed that the review component can help me filter information intelligently. DI2: I noticed that the review component has the function of intelligent keyword extraction. DI3: I noticed that the review component has a smart sorting function.
DH: Perceived operability	Huang (2003)	DH1: I noticed that it is easy to operate the review component. DH2: The review component I noticed is easy for me. DH3: I noticed that it is easy to use components.

DSI: Perceived social interaction	Novak et al. (2000)	DSI1: I noticed that I can communicate with others through components. DSI2: I noticed that I made friends when using the review component. DSI3: I noticed that I can interact with others on the review component.
PU: Perceived usefulness	Mantymaki & Salo (2011)	PU1: I felt a lot of time saved after using components. PU2: I felt that the components make my shopping/video browsing process easier. PU3: I felt that using components can help me make purchase/video browsing decisions. PU4: I felt that using components can help me learn more information.
PR: Perceived reliability	Nysveen et al. (2005)	PR1: I felt that the information provided by the review component is reliable. PR2: I felt that the information obtained through the component is real. PR3: I felt that the information provided by the component is of a certain quality.
PC: Perceived convenience	Agarwal (2000)	PC1: I felt that components make it easier for me to get information. PC2: I felt that using components allows me to get information faster. PC3: I felt that using components can make my shopping/video browsing process more smoothly.
PP: Perceived pleasure	Webster & Ho (1997)	PP1: I felt very happy when I browse the reviews. PP2: I felt that it makes me happy to support or like other users by using the review component. PP3: I felt that using components to reply to other users can make me happy.

Empirical analysis

Sample selection and data collection

In this survey, a total of 101 questionnaires were sent to platform users with experience in online shopping and video websites, and 101 valid questionnaires were returned. Descriptive statistics on valid questionnaires are seeing in the table below for details:

Table 5: Statistics report: background check

Characteristics	Types of sample	Numbers of sample	Percentage	Characteristics	Types of sample	Numbers of sample	Percentage	
Gender	Male	55	54.46%	Age	18 years old and below	1	0.99%	
	Female	46	45.54%		18-24 years old	73	72.28%	
Education	Elementary school and below	1	0.99%		25-30 years old	11	10.89%	
	Junior high school	3	2.97%		31-40 years old	4	3.96%	
	High school/ technical school/ technical school	6	5.94%		41-50 years old	5	4.95%	
	College	5	4.95%		51-60 years old	7	6.93%	
	Undergraduate college	66	65.35%		61 years old and above	0	0%	
	Master's degree and above	20	19.8%		Frequency of shopping video sites	Several times a day	11	10.89%
Frequency of viewing video	Several times a day	42	41.58%			Once a day	17	6.93%
	Once a day	21	20.79%			Several times a week	41	40.59%
				Once a week	25	24.75%		

sites	Several times a week	29	28.71%		Several times a month	15	14.85%
	Once a week	3	2.97%		Once a month or less	2	1.98%
	Several times a month	5	4.95%				
	Once a month or less	1	0.99%				
Most frequently used video sites	Tencent	22	21.78%	Most frequently used shopping sites	Taobao	87	86.14%
	IQIYI	24	23.76%		JD	5	4.95%
	Youku	7	6.93%		Suning	0	0%
	Mango TV	2	1.98%		Pinduoduo	8	7.92%
	Bilibili	41	40.59%		Amazon	0	0%
	Others	5	4.95%		Others	1	0.99%

From Table 5, it can be concluded from samples that the proportion of gender is almost balanced, most of them are undergraduate students which from 18 to 24 years old. On the one hand, the frequency of viewing video is high, nearly half of the samples view video sites several times a day. Samples are prone to concentrate on video sites like Bilibili, Tencent and IQIYI. On the other hand, the frequency of shopping video sites comparatively lower than video sites. Also, Taobao consists large percentage of markets and has obvious advantages (see Table 6 for details).

Reliability and validity analysis

This analysis refers to the Cronbach coefficient to test the internal consistency among the items. The larger the Cronbach coefficient, the higher the internal consistency between the measurement items, and the higher the reliability of the scale. The specific measurement is as follows:

Table 6: Reliability and validity analysis

Independent variable	Cronbach Coefficient	KMO	Bartley number
Integrity	0.81	0.818	752.949
Intellectual extraction	0.767	0.663	350.324
Opeability	0.775	0.74	472.361
Social interaction	0.909	0.853	1187.524
Perceived usefulness	0.92	0.864	1367.902
Perceived reliability	0.767	0.726	507.864
Perceived convenience	0.738	0.754	436.858
Perceived pleasure	0.897	0.842	1007.145

From Table 6, it can be concluded that the Cronbach coefficients of the four independent variables and the four dependent variables are all greater than 0.7, indicating the setting of the question is reasonable enough. Also, the independent variable, and the dependent variable have high consistency and structure to reach the research standards. This questionnaire is designed based on existing research conclusions, so it can ensure the content validity of the measurement items. In terms of verifying the validity of the structure, the Bartlett sphericity test, and measurement test were performed on the items set by independent variables (see Table 7 for details). Since the Bartlett value of the independent variable is significant and the KMO value is greater than 0.7, it is suitable for factor analysis. Performing factor analysis on the collected data, extracting the factors with a characteristic root greater than 1 and rotating through the Varimax surface, it can be found that the factor loads values corresponding to the same independent variable setting items exceed 0.6, which can be judged that the questionnaire has good construct validity.

Related Analysis

The purpose of the correlation test is to analyze the correlation between the characteristics of the review components mentioned above and the users' perception. The following table will test the correlation between variables.

Table 7: The correlation between variables

	Average	Standard deviation	Perceived usefulness	Perceived reliability	Perceived convenience	Perceived pleasure
Integrity	4.863	0.724	0.547**	0.045	0.029	0.094
Intellectual extraction	3.199	0.819	0.416**	0.042	0.151**	0.032
Operability	3.081	0.109*	0.031	0.007	0.233*	0.456**
Social interaction	2.852	0.752	0.041	0.346**	0.094	0.143**

Note: * Significant at $p < 0.05$ level, ** Significant at $p < 0.01$ level, the coefficients in the table are standardized coefficients

It can be seen from Table 7 that there is a correlation between the independent variables and the dependent variables. Among them, perceived usefulness is related to the integrity, the intelligent extraction of review components; perceived reliability is related to the social interaction of review components; perceived convenience is related to the intelligent extraction and operability of review components; perceived pleasure is related to the operability and the social interaction of review components. And the above relationships are all positive correlations.

Regression Analysis

This article takes perceived usefulness, perceived reliability, perceived convenience, and perceived pleasure as dependent variables, integrity, intelligent extraction, operability, and social interaction are independent variables. The regression analysis of the impact of the review component on users' perception is as follows:

Table 8: Regression analysis result of review component and perception belief

Variable	Perceived usefulness		Perceived reliability		Perceived convenience		Perceived pleasure	
	coefficient	P value	coefficient	P value	coefficient	P value	coefficient	P value
Integrity	0.124**	0.000	0.214	0.647	0.153	0.059	0.330	0.072
Intellectual extraction	0.549***	0.000	0.361	0.056	0.167**	0.041	0.304	0.054
Operability	0.101	0.424	0.141	0.531	0.103***	0.005	0.242***	0.024
Social interaction	0.437	0.253	0.188***	0.008	0.231	0.2567	0.352***	0.001
F	27.202		16.951		14.647		13.409	
R ²	0.531		0.414		0.379		0.358	
Adjust R ²	0.512		0.390		0.353		13.408	
N	101							

Note: * Significant at $p < 0.05$ level, ** Significant at $p < 0.01$ level, *** Significant at $p < 0.001$ level, the coefficients in the table are standardized coefficients

The integrity and intelligent extraction of review components have significantly positively relations with the perceived usefulness at the significant level of $p < 0.01$; The F statistic of the perceived reliability model is 16.951, the overall model fits well, meets the F test and t-test requirements, and the regression effect is significant. The significance level of social interaction is less than 0.001, indicating the social interaction of the review component significantly positively affect the perceived reliability; The F statistic of the perceived convenience model is 14.647, the overall model fits well, meets the F test and t-test requirements, and the regression effect is significant. The significance level of operability and intelligent extraction is less than 0.001, indicating the operability and intelligent extraction of review components significantly positively affect the perceived convenience; The F statistic of the perceived pleasure model is 13.409, the overall model fits well, meets the F test and t-test requirements, and the regression effect is significant. The significance levels of operability and social interaction are less than 0.001, indicating the operability and social interaction significantly positively affect the perceived pleasure. Through regression analysis, the hypothesis test results proposed in this article are supported.

DISCUSSION

Through case analysis and empirical research, we have verified that there is a correlation between review components and users' perceptions of network platforms. The different characteristics of the review component will bring different users' perceptions. By analyzing the integrity of the review component, we know that the review component has a significant positive influence on the user perceived usefulness. That is to say, the more complete the review component provided by the network platform, the more users will feel that the platform is more useful, and vice versa. This conclusion can remind the website to pay attention to whether the review component provided by its platform can meet users' all needs. Once the review component is missing, it should be

adjusted immediately to make up for the missing component, as described in the previous article. The intelligent extraction of review components has a positive influence on the perceived convenience and usefulness, and the positive influence on usefulness is more significant. This shows that the smarter the components provided by the network platform, the more useful and convenient the user will find the website to use. Therefore, if the website can keep up with the development of the Internet, update the review component in time, and optimize the function of the component, it can save users more time and energy thus improve user-experiences. The convenience and pleasure perceived by the user will be positively affected by the operability of the review component, which has a more significant impact on the perceived convenience. That is to say, if the review components are simpler and easier to use, the user will find them more convenient and will enjoy the process more. This conclusion suggests that the network platform can continue to optimize the operation mode of the review component, making the component easier and faster to display and clearer in the process of using, which can bring users a faster and more efficient user experience. The social interaction of the review component will have a positive impact on the perceived reliability and pleasure, among which the pleasure is more significant. Based on the review components, the reliability is more obvious in shopping websites, and the pleasure and social interaction are both prominent. As people spend more time on the Internet, and it is more common for friends and strangers to communicate on the Internet platform, then if the website can be more detailed and interactive in terms of social interaction, it can correspondingly improve the user experience, increase the number and using frequency of the website.

To sum up, if the review component in the network platform can pay attention to the needs of users as much as possible, respond quickly and timely to changes and increases in user needs, optimize the performance of existing review components, provide users with convenient, high-speed, efficient use of the environment, it can bring users better experiences and increase the number and using frequency of the website, thus it will bring higher browsing to the website and increase the profit of the website, which is a win-win situation for users and network platforms. .

CONCLUSIONS

From the perspective of the review component, this research analyzes the relationship between the four characteristics of review components and users' perceived beliefs. Based on the comparison and analysis of the review components, four characteristics of the review components are extracted, including integrity, intelligent extraction, operability, and social interaction. Based on the word-of-mouth theory and user perception theory, we established a theoretical model of the relationship between the four characteristics of review components and the different users' perceived beliefs and proposed 7 relationships between the two hypotheses. To verify the model, we used previous research to clarify the items to be measured, designed a questionnaire about review components and users' perceptions, and collected 101 valid questionnaires. In terms of data analysis, this study conducted factor analysis, correlation analysis, and regression analysis on the collated data. The results showed that there was indeed a correlation between review components and users' perceived beliefs. The further analysis concludes that in practice, the strategy of optimizing the function of the review component and measures to meet the changing needs of users as much as possible can improve users' perception, which provides theoretical and practical guidance for the platform to improve the existing review component system and enhance users' perception. The research results show that the relationship between review components and users' perceptions that we considered in our hypothesis is reasonable.

After conducting a case analysis on different types of websites and issuing questionnaires to the target group, the regression analysis can be used to sort out the results displayed in this research. The four characteristics of review components have four users' perceptions. There are different types of influences, and there are also different attributes between the salience of characteristics and perception. Such a result indicates the integrity of component and functions will have a corresponding impact on the use of the component to browse reviews, post reviews, and communicate with others. Therefore, if the website can provide users to meet their basic needs, it can help users reduce the economic and time loss caused by incomplete and untimely information acquisition when making decisions. From the websites' point of view, a platform for friendly communication will bring users an excellent experience to harvest more active users, improve the quality of website operations, and generate revenue for the platform. From the users' point of view, an excellent review component can save user resources and improve user-experiences.

The research has implications for improving the review component of the website. When the website changes the review component, it needs to pay attention to users' needs, and make timely and rapid remedies for the missing components in the website. At the same time, measures to optimize website functionality must be converted promptly by users' needs. By analyzing and understanding the psychological characteristics and behavioral needs of users, the website can strengthen the update and construction of components based on the conclusions drawn, and meet users' needs as much as possible. This not only enhances users' perceived value but also maintains the construction of the website and provides the competitiveness of the website. This research focuses on the corresponding relationship between the characteristics of review components and users' perceptions and conducts an empirical analysis. Although some meaningful conclusions and implications have been drawn, there are still certain limitations. This article only investigates its impact on users' perceptions from the perspective of review components, but it does not involve the overall construction of the website and other perceptions that users will generate when using the website. And due to various restrictions and force majeure factors, we have not been able to adopt a more comprehensive investigation and research method and sample. It is hoped that in future research, scholars can analyze other components related to users' perceptions, review

in more detail, and put forward more constructive theories and meanings for further improving user experience and enhancing website competitiveness.

REFERENCES

- [1] Agarwal, R. & Karahanna, E. (2000). Time flies when you are having fun: Cognitive absorption and beliefs about information technology usage. *MIS Quarterly*, 24(4), 665-694. doi:10.2307/3250951
- [2] Cheung, M. Y., Luo, C., Sia, C. L. & Chen, H. (2009). Credibility of electronic word-of-mouth: Informational and normative determinants of on-line consumer recommendations. *International Journal of Electronic Commerce*, 13(4), 9-38.
- [3] Fang, X., Chan, S., Brzezinski, J. & Xu, S. (2005). Moderating effects of task type on wireless technology acceptance. *Journal of Management Information Systems*, 22(3), 123-157.
- [4] Hennig-Thurau, T., Gwinner, K. P., Walsh, G. & Gremler, D. D. (2004). Electronic word-of-mouth via consumer-opinion platforms: what motivates consumers to articulate themselves on the internet? *Journal of Interactive Marketing*, 18(1), 38-52.
- [5] Hwang, Y. (2005). An empirical study of online trust and consumer behavior: Cultural orientation, social norms, and personal innovativeness in information technology. Paper presented at the International Conference on Information Systems, Las Vegas, NV.
- [6] Jarvenpaa, S. L. & Todd, P. A. (1996). Consumer reactions to electronic shopping on the World Wide Web. *International Journal of Electronic Commerce*, 1(2), 59-88.
- [7] Sheu, Jyh-Jian. Chang, Yao-Wen. Chu, Ko-Tsung. (2008). Applying decision tree data mining for online group buying consumers' behaviour. *International Journal of Electronic Customer Relationship Management*, 2(2): 140-157.
- [8] Moore, J. F. (1998). The rise of a new corporate form. *Washington Quarterly*, 21(1):167-181.
- [9] Morales Mediano, J. & Ruiz-Alba, J. L. (2019). New perspective on customer orientation of service employees: A conceptual framework. *The Service Industries Journal*, 39(13-14), 966-982.
- [10] Ngai, E.W. T., Gunasekaran, A. A. (2007). Review for mobile commerce research and application. *Decision Support Systems*, 43(1): 3-15.
- [11] Murphy, J., Hofacker, C. & Mizerski, R. (2006). Primacy and recency effects on clicking behavior. *Journal of Computer-Mediated Communication*, (11): 522-535.
- [12] Keen, C., Wetzels, M., De Ruyter, K. & Feinberg, R. (2004). E-tailers versus retailers: Which factors determine consumer preferences. *Journal of Business Research*, 57(7), 685-695.
- [13] Novak, T., Hoffman, D. & Yung, Y. (2000). Measuring the customer experience in online environments: A structural modeling approach. *Marketing Science*, 19(1), 22-42. doi: 10.1287/mksc.19.1.22.15184
- [14] Park, D. H., Lee J., Han I., (2007). The effect of on-line consumer reviews on consumer purchasing intention: The moderating role of involvement. *International Journal of Electronic Commerce*, 11(4): 125-148.
- [15] Rose, S., Clark, M., Samouel, P. & Hair, N. (2012). Online customer experience in e-retailing: an empirical model of antecedents and outcomes. *Journal of Retailing*, 88(2), 308-322.
- [16] Rose, S., Hair, N., Rose, S., Hair, N. & Clark, M. (2011). Online customer experience: A review of the business - to - consumer online purchase context. *International Journal of Management Reviews*, 13(1), 24-39.
- [17] Sheth, J. N. (1991). Why we buy what we buy: A theory of consumption values. *Journal of Business Research*, 22(2), 159-164.
- [18] Sirdeshmukh, D., Singh, J. & Sabol, B. (2002). Consumer trust, value, and loyalty in relational exchanges. *Journal of Marketing*, 66(1), 15-37.
- [19] Sweeney, J. C. & Soutar, G. N. (2001). Consumer perceived value: The development of a multiple item scale. *Journal of Retailing*, 77(2), 203-220.
- [20] Webster, D. M. & Kruglanski, A. W. (1994). Individual differences in need for cognitive closure. *Journal of Personality and Social Psychology*, 67(6), 1049-1062
- [21] Wilson, E. J., Sherrell, D.L. (1993). Sources effects in communication and persuasion research: Meta-analysis of effect size. *Journal of the Academy of Marketing Science*, 21: 101-112.
- [22] Wood, C., Scheer, M. (2006). Incorporating perceived risk into model of consumer deal assessment and purchase intent. *Advances in Consumer Research*, 23(1), 399- 404.
- [23] Woodruff. (1997). Customer value: the next source for competitive advantage. *Journal of the Academy of Marketing Science*, 25(2): 139-153.
- [24] Zeithaml, V. A., Parasuraman, A. & Malhotra, A. (2002). Service quality delivery through web sites: A critical review of extant knowledge. *Journal of the Academy of Marketing Science*, 30(4), 362-375.

Re-Think Insurance: A New Perspective of InsurTech

(Full Paper)

Julian Yu*, Nanyang Technological University, Singapore, jfcyu@yahoo.com.sg

Benjamin Yen, The University of Hong Kong, China, benyen@hku.hk

ABSTRACT

Technology improves performances of industries generally. While some applications impact insurance industry profoundly, however, some of the improvement is more of office automation and is better not classified as InsurTech. The article is to provide a practical perspective of InsurTech from the review of definitions and purposes of insurance, and the induction of risk information and risk financing, to silhouette insurance ecosystem and framework of InsurTech. Under risk information, the information layering is explored and the basic three elements of risk, contract and portfolio are identified in insurance ecosystem; under risk financing, transaction costs of insurance and law of large numbers are applied. Then, we propose a framework based on the three elements for InsurTech in regard of availability, affordability and assurability. Two approaches are also proposed for InsurTech development - evolutionary way to revise specific areas of the current insurance models and revolutionary way to revamp the insurance models as to redesign the arrangement of risk protection.

Keywords: InsurTech, risk information, risk financing, insurance ecosystem, assurability/insurability, availability, affordability, law of large numbers.

*Corresponding author

INTRODUCTION

In this paper, definitions, purposes and mechanisms of insurance are reviewed to outline a picture of risk protection operation and stake-holding entities' relation in insurance. Exploration is based on two major considerations, risk information and risk financing, to identify the basic elements of insurance ecosystem and features of framework of InsurTech. For risk information, it is important to adopt standards (e.g. EDI) allowing easy conversion of existing accumulated data and future expansion to connect with more data sources (e.g. IoT), and then consequently to improve the availability of risk information. For risk financing, it is critical to reduce transaction costs and to use Law of Large Numbers to improve affordability of insurance. Advancements of both will lead to improve assurability to broaden insurance application scope. From these observations, we define insurance ecosystem as "business activities with at least one of the three elements of insurance, namely risk, contract and portfolio". We further define InsurTech as "technologies to change the insurance operation for better insurance acceptance and portfolio management to improve availability, affordability and assurability". This helps to distinguish insurance evolution from other office automation. It also helps to evaluate the potential or importance of new technologies to the core value of insurance. The clarification is an attempt to make InsurTech adhering to core issues of insurance. Applications can be: (1) to improve the current business model by reviewing key points of generating profit; and (2) to redesign the protection arrangement as a new insurance business model.

LITERATURE REVIEW

In last decade, much attentions have been drawn on FinTech from both academic and business world. Many papers are discussing about InsurTech, the insurance-specific branch of FinTech initiatives. Following reviews are grouped into: (1) needs and opportunities, (2) technology adoption, and (3) risks and challenges.

- (1) Needs and opportunities. Several studies discuss the needs and opportunities of insurance industry to explore for changes. Agrawal *et al.* point out US life-insurance industry should seize the opportunity for a huge market and conclude the challenge is in the execution to best weather the inevitable storms while continuing toward their ultimate goals (Agrawal, de Gantès & Walker, 2014). Johansson and Vogelgesang (2016) study the impact of automation on insurance industry and they conclude probably 25% of full-time positions in the insurance industry may be consolidated or replaced. Rodríguez Cardona *et al.* (2019) discussed the adoption success of Chatbot Technology in German insurance sector depending on the understanding of the ambivalent perceptions, attitudes, and beliefs of the main social actors (i.e., practitioners and potential users) towards the customer interface. Yan *et al.* (2018) survey the landscape of insurance technology and its potential from the perspective of enablement for financial and insurance services. Wilson (2017) describes the future of insurance from viewpoint of technology trend and concludes if forward-thinking banks that are able to leverage InsurTech appropriately, it may enhance profitability and valuation over long term.
- (2) Technology adoption. Many papers focus on the track of technology adoption in insurance industry. Beath *et al.* (2018) studied a case of a company of merger of two banks and an insurance company exploited new data science and machine learning disciplines to transform for better customer service. Loebbecke *et al.* (2018) studied the adoption block chain in

diamond industry with customers and insurance company. They found block chain substitutes and complements for trust when trading diamonds. Yu and Yen (2018) incorporate the concept of a cryptocurrency, called Risk Coin, as the foundation of a new model to enhance the risk financing efficiency with capital market. Chester *et al.* (2016) advocate insurance carriers and actuaries should adopt the advanced analytics on top of the existing analytics in practice and explain the four-stage journey for adopting advanced analytics.

- (3) Challenges. Some papers highlight the challenges and risks issues for insurance industry. Catlin *et al.* (2018) explain the challenging digital transformation in insurance industry needs to ensure the continuity of the flow of daily business. Collins (2018) points out the penetration rate for insurance in China remains low compared to Western measures and there is plenty of headroom for growth in the China market. Onno Bloemers (2018) concludes insurers need to evolve into organizations offering a much broader set of risk management solutions. Passler (2018) discusses the key differences that are potential to deeply change, or even disrupt, the insurance industry.

In the above most of the studies concentrate on the future trend, conceptual framework, and impact study. A recent white paper for reinsurance blockchain described the issues of information imbalance in risk transferring and low level of digitalization in reinsurance transactions (Zhong An Technology, 2018). The challenges of identifying the scope and strategy of InsurTech is still the focal point. In this paper, we propose a framework of risk information not only important for the operations and decisions in insurance industry and but also crucial for standardization in realization of InsurTech.

INSURANCE – DEFINITIONS AND PURPOSES

Technology has influenced insurance operations in many ways. People expect further applications of InsurTech will lead to significant improvement or even revolution for insurance business models. To provide a clear perspective of InsurTech, it is imperative to review the fundamentals of insurance, including its definitions and purposes. First, a “risk” is the possibility of losing something of value, therefore treated as a potential financial burden of uncertainty to the responsible entity called “risk owner”. If a risk is considered insurable, the risk owner can choose to transfer the financial burden to another entity called “risk carrier” (usually insurance company) by insurance arrangements, and the financial burden becomes risk carrier’s responsibility (Figure 1).



Figure 1: Insurance Market for Insurable Risks

However, if the risk is not insurable or the price of the insurance is unaffordable, the financial burden is then retained by the risk owner. In this situation, the financial loss resulted from the risk is sustained by risk owner and its investors if any. There are various definitions of insurance, which can be grouped into two, namely legal definition and financial definition. Each one provides different focus of insurance and therefore introducing different aspect of value chains.

Legal definition of insurance for risk transfer

A common definition is legal viewpoint of insurance being a legal contract for risk transaction, and the definition can be as following:

Legal Definition of Insurance

Insurance is a contract in which one party agrees to compensate another party for losses. We call the party agreeing to pay for losses the insurer. We call the party whose loss cause the insurer to make a claim payment the insured, policyholder, or policy owner. We call the payment that the insurer receives a premium, call the insurance contract a policy, and call the insured’s possibility of loss the insured’s exposure to loss.



Figure 2: Insurance Process described by Legal Definition

The value chain in risk transaction process by formal legal contracts between different entities is as in Figure 2. According to the contractual requirements, original risk owners pay risk premium to insurance companies, who pay reinsurance premium to reinsurance companies, and then to retrocessionaires, etc. By contractual requirement, claims payments are conducted in the reverse direction. Under legal definition, contracts of direct insurance policy, reinsurance and retrocession arrangements, portray

the outlook of today’s insurance industry, and manifest following issues. One is Information asymmetry, referring to resolution reduction of risk information in each step - risk owners have the best resolution of risk information that reducing along the process either intentionally or by restriction of technology and management tools. The other one is duplicate investment that each entity in the value chain performs similar functions of information collection and risk assessment.

Consequently, the iterative transactions of insurance are often considered a zero-sum game, due to high transaction costs along the value chain. During the loss claiming stage, the insured tend to hold the mentality of externality as risk carriers are separate entities sharing no common interests. All these make insurance market less efficient. Nonetheless, the legal definition provides a strict and microscopic view of contractual activities as how entities are involved in insurance operations. However, it does not express clearly the differences of insurance comparing to other financial contracts, which calls for the financial definition of insurance.

Financial definition of insurance for risk financing

Financial definitions highlights risk pooling and loss sharing functions of insurance, two versions listed below for a complete description:

Financial Definition of Insurance - (1) Insurance is a financial arrangement that redistributes the costs of unexpected losses. (2) Insurance involves the transfer of potential losses to an insurance pool. The pool combines all the potential losses and then transfers the cost of the predicted losses back to those exposed.

In these definitions, the value chain focuses on risk-sharing function among all participants, including risk owners joining the risk sharing pools, and financiers supporting risk reallocation, as illustrated in Figure 3. The entire reallocation process is iterating into direct insurance, reinsurance and retrocessionaire as described by legal definition. Legal and financial definitions are complementary to provide a complete picture of both risk transferal and financing mechanisms. Risk transferal mechanism includes the underwriting function to decide premium rate and collect premium from the insured/ original risk owners if it is direct insurance; or the reinsured/ cedant (risk carriers to be reinsured) if it is reinsurance/ retrocession iteratively, which is then pooled as the loss sharing fund providing certain profits for financiers. Ideally, proper risk premium is charged for individual risks and collectively appropriate to fund predictable losses. Claim function will then follow the reverse distribution to reimburse the claiming insureds/cedants. Risk financing mechanism is the process of loss reallocation – (1) risk pooling to form a portfolio for reallocating predicted losses among all participants, and (2) financiers cover the differences of predicted loss amount and loss amount beyond underwriting prediction.

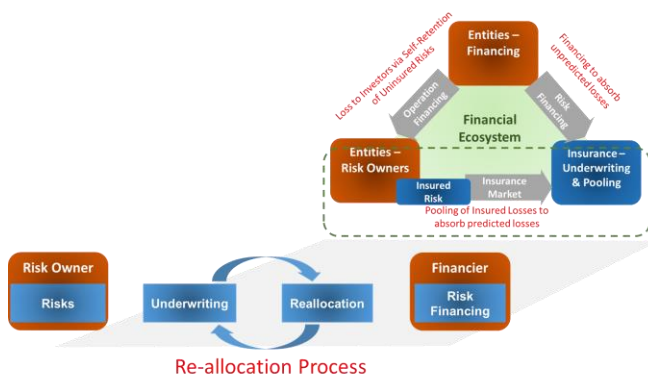

Figure 3: Insurance Process described by Financial Definition

Figure 3 illustrates stakeholders as entities performing risk pooling function for absorbing predicted losses and risk financing function for unexpected losses. Moreover, the figure extends to losses from the uninsured risks born by risk owner then forwarded to its investors. In a broader sense, all losses are born by financial markets either through insurance by risk financing or self-retention to investors as operation financing, which form a complete risk sharing picture in the financial ecosystem.

Benefit of insurance is to reduce the overall required risk capital, for the insured risks are in a risk pool to gain the benefit by Law of Large Numbers. In addition, the required capital for professional risk carrier is usually regulated to match its risk preference and strategy to further enhance its returns. Therefore, from financial point of view, insurance is a more effective way of risk management.

Stakeholders’ requirements in insurance

Stake-holding entities’ requirement in insurance are also explored to outline a new perspective of InsurTech. They are risk owner, risk carrier and risk financier in the financial ecosystem as illustrated in Figure 4.

Requirements in Insurance – (1) For Risk Owner: To obtain require protection at affordable price. A wider range of insurable risks is preferred to reduce the potential loss to risk owner and investors. (2) For Risk Carrier: To obtain risk information for underwriting, of proper risk rating for a profitable homogeneous risk pool by Law of Large Numbers. (3) For Risk Financier: To gain adequate return for invested capital with the least uncertainty of loss from the invested entities or risk pools.

From the above, we identify two major areas for improvement as follows.

(1) To improve efficiency:

- Risk Information. Availability by better information resolution of risk for underwriting and portfolio management.
- Risk Financing. Affordability from reasonable loss re-allocation and fund-raising efficiency with incentives for stakeholders.

(2) To enhance use of insurance:

- Uninsured Risks. Assurability of uninsured risks as subject of analysis to reduce undesired uncertainty and improve overall capital efficiency.

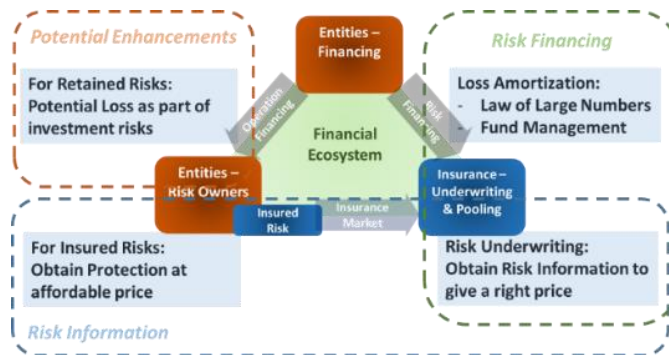

Figure 4: Requirements of Insurance by Stakeholders

In this paper, we explore these two issues in the insurance ecosystem and to review the structural knowledge of Insurance, to define the scope of InsurTech and its potential development for the purpose stated in this section.

RISK INFORMATION FOR INSURANCE

Insurance value chain composes iterative steps of risk underwriting and risk reallocation, and each step repeats complete risk transaction deal, including charging adequate premium and providing agreed limit of liability of coverage. To get the adequate premium, it requires the selection of an appropriate premium calculation base with a premium rate derived from statistical analysis of similar risks. During the risk transferal operation two objectives are achieved – calculating the premium for this specific risk transferring and enhancing the rating databases for future similar risks. The selection of premium calculation base is to find an adequate quantifiable index of risk, which shall be able to reflect the size of the exposures of the risk, so that the premium can be a reasonable monetization for the coverage and limit of liability. Collection of risk information is also important for a portfolio, that the performance of the portfolio can be reviewed to make necessary adjustment for future risk acceptance, as illustrated in Figure 5.

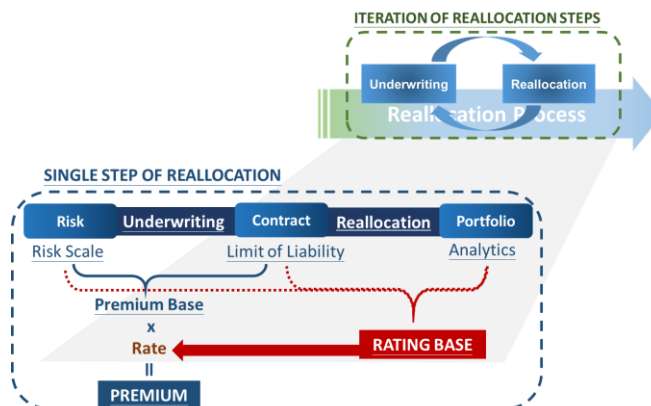

Figure 5: Single Step of Risk Transferal Operation

Risk acceptance process is composed of two complementary functions: underwriting to make use of rating base applied to selected index of a specific risk for premium calculation; and actuary to apply analytic statistics on an actual or virtual portfolio of risks and

contracts to build or maintain the rating base. The performances of both functions depend on the quality of risk information. Obviously, the improvement of technology to access and process risk information will change insurance product design. Especially the availability of real-time risk information provides more options of premium base. For example, the Usage Based Insurance of automobile policy, its coverage and liability is only activated when the vehicle is driven on road, and the drive-on-road duration is taken up for premium calculation with other traditional factors, e.g. monetary value, year of make, and vehicle model.

With more real-time information available from increasing popularity of technology, such as Internet of Things (IoT), it is believed that traditional insurance products will be revamped for more affordable arrangements. Moreover, the assurability criteria can be reviewed for traditionally non-insurable risks that may become insurable under new arrangements. Therefore, the technology which provides information as premium base for more effective insurance product to improve affordability shall be qualified as InsurTech

Risk information under insurance operation

Current model of insurance has been through few modifications. Under this model, risk information is collected manually for underwriting decision, and information systems are designed to process accepted risks only for contract administration mainly. Moreover, claims and reinsurance functions are usually loosely integrated or completely in separate systems. Consequently, the availability of risk information is very limited as illustrated in the diagram of Figure 6.

The risk information, including both insurable and non-insurable risks, can be classified in four layers by availability as: (1) Recorded Information of Insured Risk. It usually is limited and inconsistent for both inter-company and intra-company transactions. (2) Insured Risk Information. Information of insurable risks with coverage terms quoted by risk carriers and accepted by risk owners. (3) Insurable Risk Information. Information of risks that are considered insurable by risk carriers under criteria of current insurance operation. (4) Non-Insurable Risks.



Figure6. Available Information for Insurance Process

In Figure 6, there are two issues:

- Lack of smooth process of insurance operation sharing information with different systems, due to missing data sharing standard for insured risks through insurance processes and transactions between different risk carriers via reinsurance etc. InsurTech is expected to provide a solution on this issue to expand better use of available data for underwriting decision and claims handling.
- Challenges and opportunities coming with more available risk information from improved connection with data sources (e.g. IoT) to collect information of non-insured and non-insurable risks. InsurTech is expected to change from a reactive approach to a proactive one to pave way for more effective data mining of data utilization (Figure 7).

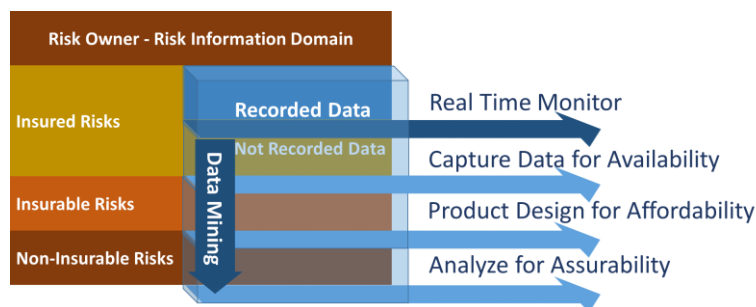

Figure7: Data Mining of Risk Information

Abundant, reliable and timely risk information will change the landscape of insurance contract design, with enhanced risk information enabling insurance contract more efficiently executed, and contract performances more promptly summarized for portfolio analysis. The broader spectrum of information will make actuarial portfolio analysis advancing from descriptive analytics to predictive analytics, or even to prescriptive analytics with real-time information for real-time decisions. All these will benefit both risk carriers and risk owners, to enable insurance to handle broader domain for non-insured or non-insurable risks. Wider range of information are then processed via actuarial analytics for simulations and comparisons with rules derived from portfolios of insured risks. Such application of information technology enhances the availability of risk information and continuously improves the affordability and assurability of insurance products. Therefore, we can conclude that the enhancement of availability, affordability or assurability is one important requirement for InsurTech.

Risk information in insurance ecosystem

Although insurance operation is part of financial ecosystem, it is helpful to define the scope of insurance ecosystem so to distinguish from other financial operations. As risk is the essence of insurance, it is necessarily included in the insurance ecosystem. Extensions can be derived from management and utilization of risk information via the processes described in legal and financial definitions:

- Legal definition: Insurance as a process to retrieve risk information for contract execution including underwriting, claims settlement etc. which repeats in reinsurance and retrocession to distribute covered risks to risk carriers along the value chain;
- Financial definition: Insurance as a process to utilize risk information to distribute losses from collected risks via insurance and reinsurance arrangements of risk carriers' portfolio to achieve the desired sharing performance.

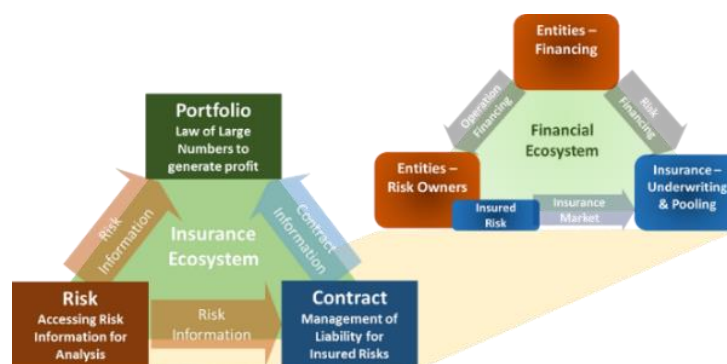

Figure8: Ecosystem of Insurance

From the above, insurance contract under legal definition and risk portfolio management under financial definition are also critical. Therefore, risk, contract and risk portfolio represent the elements in the insurance operations, to provide the landscape of insurance ecosystem. For any issue irrelevant to the three elements, it is not for insurance consideration. For example, financiers comparing performance of a particular investment portfolio with other industries is in the domain of investment rather than insurance. Another example is IoT applied in manufacturing facilities that provides torrent of risk information regarding facilities, could potentially be an issue for insurance if a contract can be formed with rating mechanism and coverages for the exposures. All insurance activities are involving one of more of the three elements, constituting insurance ecosystem as show in Figure 8.

The ecosystem framework provides a useful demarcation of InsurTech, that activity with little consideration of the three elements is irrelevant to insurance. For example, photocopier replacing handwriting on carbon papers surely improved overall performance, but such improvements are irrelevant to the three elements and therefore does not impact on insurance business models. Another example is facial recognition if it is not used to improve underwriting or claims settlement shall not be InsurTech.

Risk information and InsurTech

Risk information essentially connects risk, contract and portfolio, and for potential improvement in insurance contract design and portfolio analytics. Technology that helps improve in these areas are potentially qualified as InsurTech. The fundamental work is an information exchange standard (e.g. EDI) for availability of risk information. Such standard will allow smooth information sharing within insurance industry and external sources, therefore pave a way to an environment of highly connected operations in the insurance ecosystem. With the increase of availability, more proactive exploration to increase the data value will encouraged, which will lead to improve the affordability of coverages and eventually enhance the assurability.

The commonly used Internet nowadays can be considered as Internet of People (IoP) which has already changed social connection of people and triggered revolution in many industries (e.g. retailing and banking). Similarly, the implementation of IoT will also change industries which are focusing on operation or connection of constructions and apparatus. The accumulated data, externally or in insurance industry, can be used to support of underwriting activity as a goldmine for the discovery of un-manifested actuarial

principles, especially once the cross-reference is established with risk information that has not been captured in the past. This requires easy data conversion that the EDI needs to be well defined in a flexible way as building blocks to contain variable risk information formats across insurance with other industries. Insurance industry will eventually benefit from the implementation of an overall digitalized ecosystem. However, it will make thing happened easier if insurance industry liaises the appeal of InsurTech for other industries' purposes, that insurance can be the guidance of information integration for general purposes.

The cost reduction can also a driving force that development and maintenance of insurance information system are increasing. Together with the requirements to handle growing interactions, the EDI standard can be the groundwork for open API standards or shared OS to drive the system cost down. Moreover, abundant risk information together with security technology like blockchains may dramatically increase information volume and stringent requirement of sharing common information. One potential solution to reduce the cost is risk information sharing in Cloud for underwriting decisions and other actuarial analysis, which can be achieved easily in an EDI environment.

RISK FINANCING

Two ways for loss financing from a risk: one is by insurance market for insurable risks with affordable premium, the other is by financial market for risks considered uninsurable or with unaffordable premium and therefore self-retained by risk owners and their financial supporters. For risks placed to insurance market, losses are transferred to risk pools with volatility reduction by Law of Large Numbers which allows less capital for financial protection than the summation of capital required by individual risk owners if self-retained. Such transferring can repeat that Risk Carriers can reduce their volatility to reach a desired level of risk homogeneity. To avoid confusion, insurance within overall business relations are illustrated in Figure 9.:

- Insurance Market: Risk accepted by entities other than the risk owners via transferring contracts of insurance, reinsurance or retrocession.
- Financial Market: Risk retained by owners with their creditors via by ownership or debt/bond, etc. Also, insurers are financed by Financial Market.



Figure 9: Complete View of Risk Sharing

Equivalence equations of insurance operation

The traditional equivalence equation (Borch, 1984) is extended to financier's involvement as:

Equation 1

$$\sum_t W_t + \sum_t \sum_s Claims_{s,t} = \sum_t X_t + \sum_t \sum_s Premium_{s,t}$$

- \sum_s : Summation of premiums or claims, footnote s indicates different insureds;
- \sum_t : Summation of amounts for a period of insurance usually by years, footnote t indicates different years;
- Risk sharing by pooling of all premium and claims, and by certain periods of continuous years;
- Profit or loss of the pool to the investors who will adjust by W_t and X_t on annual basis.

For individual insured:

Equation 2

$$\sum_t w_t + \sum_t Claim_t = \sum_t x_t + \sum_t Premium_t$$

- Footnote s is fixed;
- Over a certain period, it is ideal to approach equilibrium as $\sum_t Claim_t = \sum_t Premium_t$;
- Premium before significant claims is decided by underwriting from previous experiences of its own and similar risks;
- Premium after significant claims is increased in following renewals to "payback" claims payment.

Modified Equation for Financial Definition:

Equation 3

$$\sum_t \sum_s Claims_{s,t} = \sum_t \sum_s Premium_{s,t} + \sum_t (X_t - W_t)$$

- W_t and X_t are summations of w_t and x_t for individual insureds, to demonstrate Risk Financing from Risk Capital;
- Premium pooled to share predicted losses, and risk capital as additional fund for unpredicted losses;
- Law of Large Numbers to stabilize returns.

For transaction cost and loss/profit of portfolio:

Equation 4

$$\sum_t (W_t - X_t) = \sum_t \sum_s Premium_{s,t} - \sum_t \sum_s Claims_{s,t}$$

- Loss/profit generally is an issue of daily underwriting management;
- However, transaction cost included in the above can be an issue of overall environment and technology.

Transactions Costs of insurance

“If Insurance is efficient to reduce volatility, why we still do self-retention for some or part of the risks?” (Coase, 1937). Insurance protection can be considered as time based rental contracts of risk financing capital. Therefore, we can apply the concept of Sharing Economy to treat self-retention as “owning” and insurance as “renting” the required protection.

Transaction costs for insurance can be explained as:

- *Transfer Cost*, to match demand and supply, e.g. brokerage and commission;
- *Triangulation Cost*, to collect information for underwriting and claims decisions, e.g. loss survey;
- *Trust Cost*, for potential failure of contract execution, e.g. capital cost to improve the solvency.

The costs mutually correspond to each other. For example, parametric products to simplify loss measurement (reducing triangulation cost) cause concerns of not reflecting true scenarios and may impact support from lacking trust (increasing trust cost). Another example is Finite Risk Reinsurance (reducing triangulation cost), requiring obligation for multiple year agreement (increasing trust cost). Currently InsurTech focuses on transfer cost as it is easier to be observed, though triangulation cost and trust cost are also important to market efficacy. A conceptual diagram (Pearson, 2019) is an excess of loss reinsurance arrangement to explain reinsurance transactions usually made for middle layers, as high costs hamper the transaction for primary layer from frequent losses (losses of short return period) and for high layers from extra-large scale losses (losses of very long return period), as illustrated in Figure 10:

- X axis - loss amount specified by return period of loss, longer return period represents higher loss amount.
- Y axis - transaction cost by triangulation and trust are, assuming no or fixed transfer cost.
- Triangulation cost is from high left to low right, as usually it is harder to measure daily work for small losses with high frequency, while it is relatively cheaper to estimate loss of longer return period by catastrophe modeling.
- Trust cost is from high right to low left, as usually it is less concerned on small losses and critical for solvency issues. Losses of long return period may be omitted and reducing predicted loss range, to call for financial support with increased trust cost.
- Summation of triangulation and trust costs is high at both ends, explaining such protection is usually for middle range.

Each cedant has its own preference as illustrated in red lines that Cedant B prefers lower layer protection than Cedant A.

This diagram also indicates potential effects of technology, that improving risk information availability will probably help reducing triangulation costs, while blockchain applications should probably focus on trust cost over solvency or large losses.

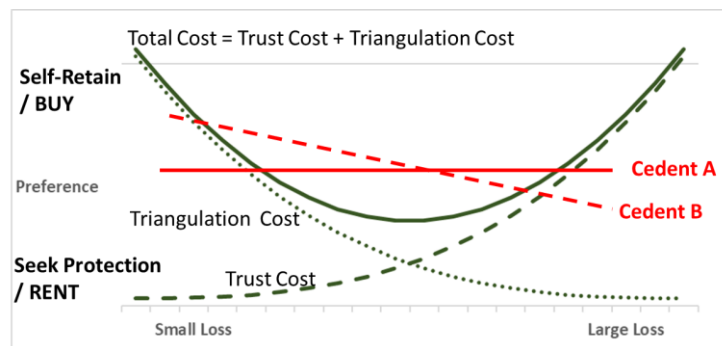

Figure 10: Triangulation Cost and Trust Cost in Excess of Loss Arrangement

Law of large numbers and insurance ecosystem

Uncertainties can be reduced by better quality or management, but not possible to be eliminated completely. To manage uncertainty at least for financial impacts, Law of Large Numbers LLN is applied. Quality and quantity of risk pools are affecting

the performance of LLN. To simplify our analysis, quantity is defined as number of risks, and quality is defined as the similarity of risks to manifest the inherited nature by the availability of risk information. Both requiring insurance companies to allocate limited resources in collecting risk information or soliciting risk owners as clients. The limited resource forms line segments in Figure 11 that more risk information collection will reduce the solicited number of risks. Each company's curve sits at different position as insurance or reinsurance companies due to its expertise, scale and capital strength. When seeking reinsurance support, cedants present their portfolio to reinsurers benefitted by less effort in collecting risks but with less risk information resolution due to cedants' abstract risk presentations, contractual requirement, or technology restriction for reinsurers to process detail information. The exchanges forms Risk Transfer Curve in Figure 11, that cedants have better resolution in Risk Information while reinsurance companies have advantage in Number of Risks, and transactions occur when both parties benefitted from the deal.

InsurTech is expected to improve availability of risk information for improvement in risk pricing and selection. Such improvement will change resource line segments to become flatter as in Figure 12. Since the improvement is open to all companies, a new risk transfer curve may appear as the red solid line on the right in the figure. However, such curve does not indicate a stable market as all companies have similar level of risk information, and therefore resulting to fierce competition on soliciting risks. Boundaries of insurance, reinsurance and retrocession will probably become vague if not totally vanish.

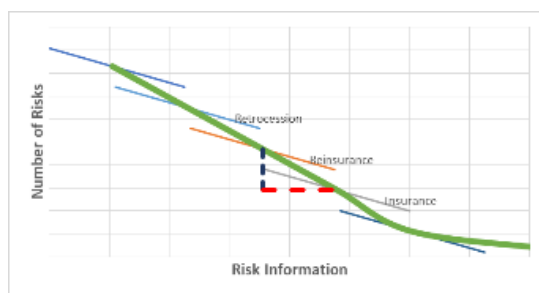

Figure 11: Company Resource Line Segment and Risk Transfer Curve

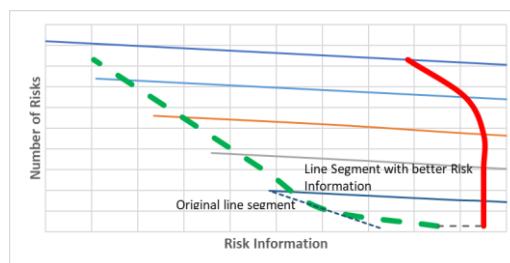

Figure 12: Resource Curve changing with increasing availability of Risk Information

The competition is likely to generate a spiral effect to enhance further competition to improve affordability of insurance products and assurability to narrow up protection gap.

PERSPECTIVE OF INSURTECH

The deployment of technology helps in many ways and some may improve the overall efficiency of human society. For example, the photocopier replaces duplicate hand-writing documents, and computers assist actuarial calculation for catastrophe simulation. However, if any technology applied in insurance is called InsurTech, this term will be vague and probably misunderstood.

To be a meaningful perspective of InsurTech, three important characteristics shall be included:

- *Availability.* Risk information and insurance products available for transaction decision.
- *Affordability.* Transaction cost reasonable for risk owners and profitable for risk financiers.
- *Assurability.* Law of Large Numbers applied to broader range in products and innovated insurance models.

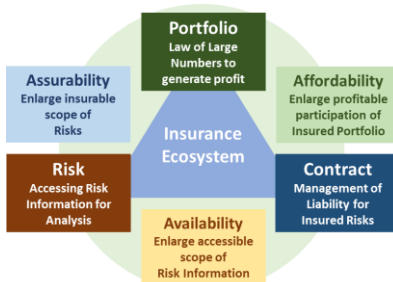

Figure 13. Elements of Insurance Ecosystem and Features of InsurTech

A framework of InsurTech is then proposed:

Technologies to improve availability, affordability and assurability of insurance ecosystem that is composed of risks, contracts and portfolios for loss sharing and volatility reduction.

This framework highlights the core value of technology to provide guidance in resource allocation for InsurTech implementation within insurance ecosystem, as illustrates in Figure 13. Based on this framework, we are able to explore the potential of InsurTech in: (1) improving current business model and (2) redesign business model.

Improving current business model

We are reviewing current business model in the critical steps of insurance value chain, and the potential improvements in information management as following.

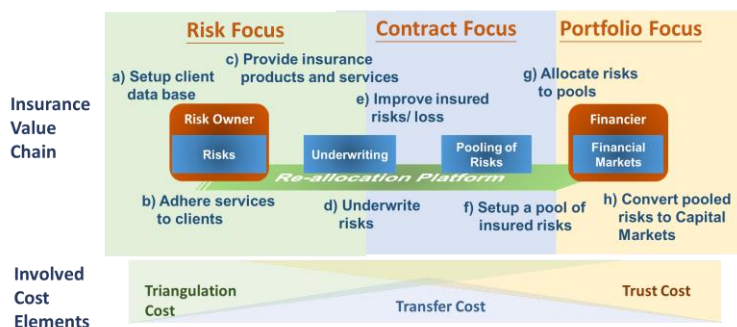

Figure 14: InsurTech to Improve Current Insurance Model

In the insurance value chain shown in Figure 14, eight activities are highlighted for making profit or saving cost under current business model: (a) Setup data bases of potential clients; (b) Adhere services to the target clients; (c) Provide products and services to the clients; (d) Underwrite risks; (e) Risk improvement before or after losses; (f) Setting risk pools by retention or treaty; (g) Allocate risks to pools by Law of Large Numbers; and (h) Convert insurance portfolio to financial market. A technology is classified as InsurTech in these activities if it has significant improvement on availability, affordability or assurability. For example, Internet marketing helps in steps (1), (2) and (3), but it is a general marketing tool for all kinds of products or services, not necessarily qualified as InsurTech unless it assists efficiently in risk information collection and transmission for underwriting assessment and risk condition monitoring, it is improving risk information availability and then qualified as InsurTech.



Figure 15: Information Management for Insurance Industry

Also, we can review the potential improvements of in information management in following six layers as shown in Figure 15: (1) Credit Information; (2) Settlement Management; (3) Technical Accounting; (4) Policy & Placement Management; (5) Risk Exposure Information; and (6) Background Information. Technology is considered InsurTech if it helps improving the efficiency for the management in each layer, or the linkage of information between layers. For example, the EDI for insurance operation is a proposal to link components (3), (4) and (5) (Yu & Yen, 2018).

We can also combine these two to review technology applicable to insurance. Current IT mainly focuses on the reduction of transfer cost, and it may require external connections for reduction of triangulation cost and trust cost.

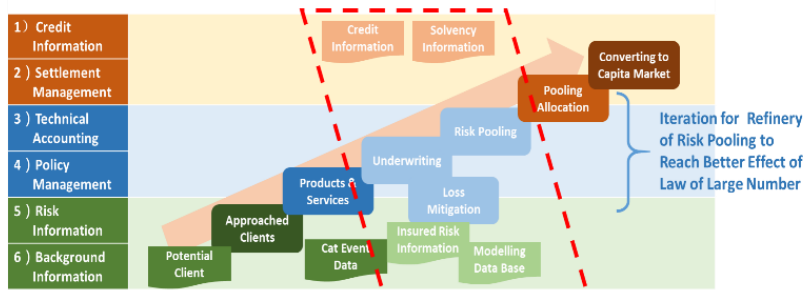

Figure 16: Evaluation of New Technology in Value Chain

Moreover, to evaluate the potential application or impact of a new technology, we can check areas less aware or worked upon in the value chain (Figure 16), or in the data structure (Figure 17).

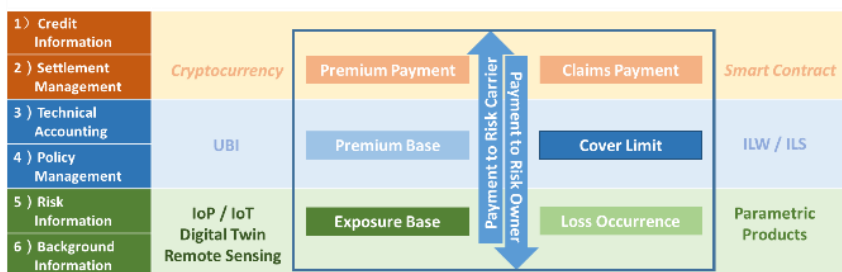

Figure 17: Evaluation of New Technology in Data Structure

Redesign business model

Technologies which helps in the process from accessing risk information to risk financing will assist in redesigning insurance model. From the proposed definition of InsurTech, we can expect the redesigned model to achieve the objectives set in the framework:

- *Availability.* Access required risk information of insurance processes on universal platforms.
- *Assurability.* Research on application of Law of Large Numbers to reduce volatility.
- *Affordability.* Review elements in transaction costs to provide affordable insurance products.

Therefore, one possible scenario is an integrated universal information platform to reach the objective of availability providing a smooth transaction and data exchange environment, with portals receiving data from external sources (e.g., IoT, wearables and geo data). The data collected via this platform shall not be limited to the insured or insurable risks, it shall also cover the non-insurable risks. By doing this, the platform can also assist in research for assurability to check the potential improvement in risk financing arrangement by Law of Large Numbers. This will be essential for new product design to enhance both assurability and affordability.

CONCLUSIONS

From definitions of insurance and purposes of entities in insurance, risk information and risk financing are identified as research background in this paper.

- (1) In the exploration of risk information, we review the required underwriting information and clarify insurance ecosystem with three critical elements, risk, contract and portfolio. A universal platform with standard of data structure (e.g., EDI) is then proposed for smooth insurance operation as a new environment for ecosystem.
- (2) In the exploration of risk financing, we apply Coase Theorem to explain why insurance transaction can or cannot be made based on the transaction cost considerations, and how Law of Large Numbers is affecting the entire industry. Observations are then used in the framework of InsurTech for the assessment of potential impact of new technologies.

From the above, the framework of InsurTech is defined as technologies to improve insurance business model regarding availability, affordability and assurability. Both evolutionary and revolutionary approaches are proposed for InsurTech development, which is expected to provide guidance for proper resource allocation for both improvements in current business model and as a roadmap for innovation of new models.

REFERENCES

- [1] Agrawal, V., de Gantès, G., & Walker, P. (2014). Life Journey: Winning in the Life-Insurance Market. *McKinsey & Company*.
- [2] Beath, C., Tarafdar, M., & Ross, J. (2018). OneBankAssure: customer intimacy through machine learning. In *International Conference on Information Systems (ICIS)*, AIS Electronic Library, San Francisco, USA, Dec 13-16, 2018
- [3] Borch, K. (1984). Equilibrium premiums in an insurance market. *Journal of Risk and Insurance*, 51(3), 468-476.
- [4] Catlin, T., Lorenz, J. T., & Morrison, C. (2017). Insurers' Digital Reality—Fewer Premiums, More Competition. *McKinsey & Company*.
- [5] Catlin, T., Lorenz, J. T., Nandan, J., Sharma, S., & Waschto, A. (2018). Insurance Beyond Digital: The Rise of Ecosystems and Platforms. *McKinsey & Company*.
- [6] Chester, A., Clarke, R., & Libarikian, A. (2016). Transforming into an Analytics-Driven Insurance Carrier. *McKinsey & Company*.
- [7] Coase, R. H. (1937). The nature of the firm. *Economica*, New Series, 4(16), 386-405. <https://onlinelibrary.wiley.com/doi/epdf/10.1111/j.1468-0335.1937.tb00002.x>
- [8] Collins, R. (2018). Chapter 22 - Insurance in China, In Sabine L. B. VanderLinden, Shân M. Millie, Nicole Anderson, & Susanne Chishti, *The InsurTech Book: The Insurance Technology Handbook for Investors Entrepreneurs and FinTech Visionaries*, Wiley, UK.
- [9] Johansson, S., & Vogelgesang, U. (2016). Automating the insurance industry. *The McKinsey Quarterly*.
- [10] Loebbecke, C., Lueneborg, L., & Niederle, D. (2018). Blockchain technology impacting the role of trust in transactions: Reflections in the case of trading diamonds. In *Twenty-Sixth European Conference on Information Systems (ECIS2018)*, Portsmouth, UK, 2018.
- [11] Onno Bloemers, J.H.F. Chapter 44 - The Future of Insurance – From Managing Policies to Managing Risks, In Sabine L. B. VanderLinden, Shân M. Millie, Nicole Anderson, & Susanne Chishti, *The InsurTech Book: The Insurance Technology Handbook for Investors Entrepreneurs and FinTech Visionaries*, Wiley, UK.
- [12] Passler, K.H. Chapter 6 - “Real” InsurTechStartups do it differently! In Sabine L. B. VanderLinden, Shân M. Millie, Nicole Anderson, & Susanne Chishti, *The InsurTech Book: The Insurance Technology Handbook for Investors Entrepreneurs and FinTech Visionaries*, Wiley, UK.
- [13] Pearson, T (2019). Markets are Eating the World. <https://taylorpearson.me/markets-are-eating-the-world-book/>
- [14] Rodríguez Cardona, D., Werth, O., Schönborn, S., & Breitner, M. H. (2019). A mixed methods analysis of the adoption and diffusion of chatbot technology in the German insurance sector. In *Twenty-fifth Americas Conference on Information Systems*, Adoption and Diffusion of Information Technology (SIGADIT).
- [15] Wilson, Jay D. (2017) *Creating Strategic Value through Financial Technology* (Chapter 8 - InsurTech and the future of insurance), John Wiley & Sons, Inc.
- [16] Yan, T. C., Schulte, P., & Chuen, D. L. K. (2018). InsurTech and FinTech: banking and insurance enablement. In *Handbook of Blockchain, Digital Finance, and Inclusion, Volume 1* (pp. 249-281). Academic Press.
- [17] Yu, J. & Yen, B. (2018). A Cryptocurrency based Insurance Model. In *Proceedings of The 18th International Conference on Electronic Business (ICEB)*, Guilin, China, December 2-6.
- [18] Yu, J., & Yen, B. P. (2018). Basic Risk Information Component (BRIC) and Insurance. In *Cross Strait Conference of Information Management Development and Strategy*. Hong Kong.
- [19] Zhong An Technology (2018). China Reinsurance Group, Hannover Reinsurance Shanghai Branch. General Reinsurance Shanghai Branch - White Paper for Reinsurance Blockchain. <https://www.reinsurancene.ws/hannover-re-joins-new-chinese-reinsurance-blockchain-initiative/>

Role of Social Media in Creating Awareness during COVID-19 Pandemic

Tahany Almotawa, Imam Abdulrahman Bin Faisal University, Saudi Arabia, 2200500256@iau.edu.sa
Duaa Aljabri*, Imam Abdulrahman Bin Faisal University, Saudi Arabia, daljabri@iau.edu.sa

ABSTRACT

Social media (SM) applications have played a critical role for the rapid dissemination of information during the COVID-19 pandemic. Limited insight is provided into the main reliable SM source for information and awareness about the pandemic. This study examines the role of SM applications in creating awareness during the pandemic in Saudi Arabia. The study used a quantitative approach and distributed an online questionnaire via SM platforms during October 2020 and received 343 valid responses from university students, healthcare professionals, and the public. Findings showed that despite the wide use of SM applications, the MOH website was the main source of information relied upon during the pandemic. Gender differences were found on the reliance of SM platforms for information. Developing SM policies and best-practice guidelines are necessary to better perceive SM applications as effective public health educational sources and awareness channels during crises.

Keywords: Social Media, COVID-19, Coronavirus, Pandemic, Awareness, Ministry of Health

*Corresponding author

INTRODUCTION

The wide development and emergence of social media (SM) applications during the last decade has played a critical role in sharing information. Examples of such SM applications are Facebook, Instagram, LinkedIn, Twitter, Telegram, YouTube, and WhatsApp. Each SM application has its own characteristics and limitations of the type of media being shared in forms of video, photo or text. The current number of SM users worldwide are 3.6 billion, which is increasing dramatically and expected to reach 4.41 billion by 2050 (Clement, 2020). SM contributes actively to marketing, sport, technology, healthcare, education, activism and social awareness. On the other hand, SM has dark sides, such as addiction, mental illness, information misleading, cyberbullying, and hacking (Nirajan, 2020).

Among Middle Eastern countries, Saudi Arabia, a country with a population of 34.54 million, recorded 25 million (72.38%) active SM users in January 2020. This number increased by 2.0 million (+8.7%) between April 2019 and January 2020 (Kemp, 2020). According to recent national statistics (2020), more than 70% of the population are actively using SM due to the high rate (92%) of smartphone ownership. Saudi Arabia is one of the biggest national markets for SM, and people are spending on average, three hours daily on SM. The majority of SM users are accessing YouTube (76%), followed by WhatsApp (71%), Instagram (65%), Twitter (58%), and Snapchat (45%) (Kemp, 2020).

Social media users become more active during any event worldwide such as Arab spring and COVID-19 pandemic crisis and during Middle East Respiratory Syndrome (MERS-CoV) attack. 2015, a cross-sectional study was conducted in the Gulf countries and target 2741 individuals to check public awareness during the MERS-CoV attack. The study shows that 37% of Saudi people accessing social media platforms, and 20% of them access the MOH website as sources to obtain knowledge about MERS-CoV (Alqahtani *et al.*, 2017).

The widespread use of SM enhanced awareness among health information seekers. Al-Dmour *et al.* (2020) found that the use of SM applications had substantial, positive influence on public health protection against COVID-19. Another study on the safety practices during COVID-19 pandemic in the city of Riyadh, Alahdal *et al.*, (2020) found that that 58% of the participants had a moderate level of awareness. On the dark side, some SM can disseminate misleading or false information (Kaicker *et al.*, 2013). While the quantity of online health information is huge, some information is not trustworthy (Tonsaker, Bartlett & Trpkov, 2014). Misinformation compromises the health care quality, threatens public safety, and increases panic among patients. Therefore, it is critical that the public accesses credible health-information. The use of SM platforms has dramatically increased during the COVID-19 pandemic. The SM usage among adults in United States increased by 50% (Samet, 2020). A global study about the use of SM during Coronavirus pandemic found that more than 35 % of the SM users in the United States, Italy and Germany were searching for updated coronavirus news on at least daily basis (Watson, 2020).

There is limited insight into the main reliable SM source for information and awareness during COVID-19 pandemic. As health information dominates the Internet, particularly the social networking sites, it is important that reliable information is disseminated through verified sources. Otherwise, false, divergent, or contradicted information can be circulated, raising uncertainty and fear in the community.

In this study, we raised three research questions on the role of SM during the pandemic: 1) What is the main SM source for COVID-19 information?, 2) What is the extent of SM attitudes during the pandemic?, and 3) What is the extent of reliance on SM in the population?

RESEARCH METHODOLOGY

This is a cross-sectional study based on a questionnaire asking participants about their main SM source for information during the COVID-19 pandemic, their SM attitudes, and their most relied SM source for COVID-19 awareness. The questionnaire had four sections described in further detail below (see the Appendix). It was reviewed for face and content validity by four academic experts, and then piloted among twelve participants to ensure clarity. The questionnaire was then distributed online during the four weeks of October, 2020, via an invitation message with the questionnaire link across different social media platforms, such as Facebook, Twitter, and WhatsApp. The targeted sample population was composed of adults aged 18 years or above. A convenient random sample of 343 participants answered the questionnaire.

Section A of the questionnaire collected demographic data: age, sex/gender, education level, and geographic location. Section B collected COVID-19-related questions, such as being worried to be infected, self-isolation due suspicion of being infected, and being diagnosed with a positive COVID-19 infection. Section C collected data about the extent of SM attitudes. Section D collected questions about the extent of reliance on different SM sources. A five-point Likert scale that ranged from 'always=5' to 'never=0' was used, which was converted to a mean score for analysis. Participants consent was implied by completion of all questionnaire items. The data collected were analysed using the Statistical Package for Social Sciences (SPSS) software via a descriptive analytical approach. The proportion of participant nominal groups were compared using chi-square test. As the data showed normal distribution, ANOVA test was used to compare the mean across the three groups: university students, healthcare professionals (HCP), and non-healthcare professionals (Non-HCP). Bonferroni post-hoc correction was applied to pinpoint the pairs of means that were different. P-value of 0.05 was considered significant.

RESULTS

Table.1 shows that the data were collected from 343 participants. More than 81% of the participants were females and 19% were males. The mean age was 34.45 ± 9.9 years (ranged 18–62), and 84.5% lived in the Eastern Province of Saudi Arabia. More than half the sample had higher education studies with either a bachelor (42.6%) or a graduate degree (11.1%). About 21% of the participants were university students, 30.0% were HCP, and 49% were non-HCP. Across many SM sources, the Ministry of Health (MOH) website was the highest perceived source for COVID-19 related information (54.2%), followed by Twitter (14.9%) and other sources (7.9%). More than half the sample were worried to be infected by COVID-19 (54.8%), and 47.8% isolated themselves for a period of 10.53 ± 8.1 days because they suspected to be infected by COVID 19. However, only 12.5% had positive disease diagnosis.

Table 1: Summary Statistics (N=343)

Study Data	Total Sample - N (%)
Sex/Gender	
Male	65 (19.0)
Female	278 (81.0)
Age in years, mean \pm SD	34.45 \pm 9.9
Education level	
Middle School or less	18 (5.2)
High School	69 (20.1)
Certificate or Diploma	72 (21.0)
Bachelor Degree	146 (42.6)
Graduate Studies	38 (11.1)
Geographic Region	
Eastern Province	290 (84.5)
Others	53 (15.5)
Participant Category	
University Student	71 (20.7)
Healthcare Professional	103 (30.0)
Non-Healthcare Professional	169 (49.3)
Where do you get most information about COVID-19?*	
Facebook	1 (0.3)
Instagram	26 (7.6)
Twitter	51 (14.9)
YouTube	8 (2.3)
WhatsApp	44 (12.8)
Ministry of Health website	186 (54.2)

Other sources [†]	27 (7.9)
Are you worried to be infected by COVID-19? (Yes)	188 (54.8)
Have you ever isolated yourself due to a suspicion of COVID-19 infection? (Yes)	164 (47.8)
Days spent in isolation, mean ± SD	10.53 ± 8.1
Have you been diagnosed with positive COVID-19? (Yes)	43 (12.5)

*Groups are mutually exclusive. Participants check only one option.

[†]Other sources e.g. family, peers, news, and medical journals.

Using ANOVA tests, Table 2 shows differences in COVID-19-related questions across groups of university students, HCP, and non-HCP. Non-HCP were the highest group to report that they were worried to be infected (46.3%), isolated themselves as a suspicion of infection (48.2%), and were positively diagnosed with COVID-19 (60.5%). Significant differences were observed in the most used source of information across groups ($P < 0.05$).

Table 2: COVID-19-related Questions across Participant Groups

Variables	University Students N=71	Healthcare Professional N=103	Non Healthcare Professional N=169	P-value
1. Are you worried to be infected by COVID-19? (Yes)	46 (24.5%)	55 (29.3%)	87 (46.3%)	0.15
2. Have you ever isolated yourself due to a suspicion of COVID-19 infection? (Yes)	32 (19.5%)	53 (32.3%)	79 (48.2%)	0.65
3. Days spent in isolation, mean ± SD	8.94 ± 6.1	9.02 ± 6.8	12.19 ± 9.3	0.04
4. Have you been diagnosed with positive COVID-19? (Yes)	4 (9.3%)	13 (30.2%)	26 (60.5%)	0.11
5. Where do you get most information about COVID-19?				
Facebook	0 (0.0%)	1 (100%)	0 (0.0%)	<0.00
Instagram	4 (15.4%)	2 (7.7%)	20 (76.9%)	
Twitter	20 (39.2%)	8 (15.7%)	23 (45.1%)	
YouTube	5 (62.5%)	3 (37.5%)	0 (0.0%)	
WhatsApp	10 (22.7%)	4 (9.1%)	30 (68.2%)	
Ministry of Health website	29 (15.6%)	77 (41.4%)	80 (43.0%)	
Other sources	3 (11.1%)	8 (29.6%)	16 (59.3%)	

Table 3 shows the extent of SM attitudes during COVID-19 pandemic. The statistics show the most dominant attitude was finding videos (mean SD 3.22 ± 0.79), followed by thinking that COVID-19 information on SM are important (2.65 ± 0.89), and applying the information received from SM media (2.36 ± 1.05)

Table 3: Social Media Attitudes during COVID-19 Pandemic among the Total Population (N=343) – N (%)

Attitudes	Never	Rarely	Sometimes	Often	Always	Mean ±SD
1. How often do you find videos, articles and blogs on social media talking about COVID-19?	1 (0.3%)	3 (0.9%)	62 (18.1%)	128 (37.3%)	149 (43.4%)	3.22 ± 0.79
2. How often do you follow pages, profile, vlogger or blogger providing information regarding COVID-19?	22 (6.4%)	53 (15.5%)	133 (38.8%)	94 (27.4%)	41 (12.0%)	2.23 ± 1.05
3. How often do you share content regarding COVID-19 through social media?	65 (19.0%)	96 (28.0%)	110 (32.1%)	46 (13.4%)	26 (7.6%)	1.62 ± 1.15
4. How often do you attend online lectures/symposium related to COVID-19 organized by professional organization?	155 (45.2%)	79 (23.0%)	74 (21.6%)	22 (6.4%)	13 (3.8%)	1.00 ± 1.12
5. How often do you think that information regarding COVID-19 on social media are important?	4 (1.2%)	25 (7.3%)	118 (34.4%)	134 (39.1%)	62 (18.1%)	2.65 ± 0.89

6. How often do you apply the information received from social media about COVID-19?	17 (5.0%)	51 (14.9%)	116 (33.8%)	109 (31.8%)	50 (14.6%)	2.36 ±1.05
--	--------------	---------------	------------------------------	----------------	---------------	------------

Table 4 shows that across the study groups, HCP were significantly higher than university students and non-HCP to share content and attending online lectures related to COVID-19 ($P < 0.00$).

Table 4: Social Media Attitudes during COVID-19 Pandemic across Participant Groups – Mean ±SD

Attitudes	University Students N=71	Healthcare Professionals N=103	Non-Healthcare Professionals N=169	ANOVA F-test	P-value
1. How often do you find videos, articles and blogs on social media talking about COVID-19?	3.29 ±0.76	3.26 ±0.75	3.17 ±0.82	0.69	0.49
2. How often do you follow pages, profile, vlogger or blogger providing information regarding COVID-19?	2.38 ±1.06	2.16 ±1.05	2.20 ±1.05	0.95	0.38
3. How often do you share content regarding COVID-19 through social media?	1.46 ±1.16	2.00 ±1.10	1.46 ±1.13	7.96	0.00
4. How often do you attend online lectures/symposium related to COVID-19 organized by professional organization?	0.87 ±1.19	1.67 ±1.14	0.65 ±0.88	32.30	0.00
5. How often do you think that information regarding COVID-19 on social media are important?	2.67 ±0.95	2.66 ±0.99	2.63 ±0.81	0.06	0.94
6. How often do you apply the information received from social media about COVID-19?	2.39 ±1.18	2.29 ±1.07	2.39 ±0.99	0.32	0.72

Table 5 shows the extent of reliance on COVID-19 related information disseminated in the social media. The statistics show the most dominant SM source relied upon among participants is the MOH website (mean SD 3.21 ±1.12), followed by WhatsApp (2.35 ±1.24), and Twitter (2.05 ±1.40). While 57.1% confirmed that they will always rely on MOH as a source of COVID-19 information, participants recorded that they will never rely on other sources such as Facebook (48.4%), Telegram (44.3%), or other sources (36.2%).

Table 5: Reliance on Social Media Sources for COVID-19 Awareness among the Total Population (N=343) – N (%)

Sources	Never	Rarely	Sometimes	Often	Always	Mean ±SD
Facebook	166 (48.4%)	125 (36.4%)	34 (9.9%)	10 (2.9%)	8 (2.3%)	0.74±0.91
Instagram	75 (21.9%)	84 (24.5%)	96 (28.0%)	53 (15.5%)	35 (10.2%)	1.67 ±1.25
Twitter	67 (19.5%)	60 (17.5%)	71 (20.7%)	77 (22.4%)	68 (19.8%)	2.05 ±1.40
YouTube	83 (24.2%)	81 (23.6%)	89 (25.9%)	67 (19.5%)	23 (6.7%)	1.60 ±1.23
Telegram	152 (44.3%)	117 (34.1%)	55 (16.0%)	11 (3.2%)	8 (2.3%)	0.85 ±0.96
WhatsApp	37 (10.8%)	40 (11.7%)	105 (30.6%)	87 (25.4%)	74 (21.6%)	2.35 ±1.24
MOH website	17 (5.0%)	13 (3.8%)	45 (13.1%)	72 (21.0%)	196 (57.1%)	3.21 ±1.12
Other sources	124 (36.2%)	81 (23.6%)	60 (17.5%)	37 (10.8%)	41 (12.0%)	1.38 ±1.37

Table 6 shows significant differences across the study groups on their SM reliance. Bonferroni post hoc test further revealed that healthcare professionals were significantly more likely to rely more on Telegram and the MOH website than non-healthcare professionals ($P < 0.02$). Both HCP and University Students were significantly more likely to rely on YouTube than Non-HCP ($p < 0.05$). Insignificant differences were found in the other SM sources, which indicated that all groups were similar in reliance on those applications.

Table 6: Reliance on Social Media Sources for COVID-19 Awareness across Participant Groups – Mean ±SD

Source	University Students N=71	Healthcare Professionals N=103	Non-Healthcare Professionals N=169	ANOVA F-test	P-value
Facebook	0.70 ±0.94	0.89 ±1.00	0.66 ±0.84	2.00	0.137
Instagram	1.56 ±1.28	1.58 ±1.15	1.78 ±1.30	1.16	0.315
Twitter	2.53 ±1.29	2.11 ±1.35	1.81 ±1.42	6.90	0.00*
YouTube	1.85 ±1.37	1.77 ±1.15	1.40 ±1.18	4.89	0.00*

Telegram	0.85 ± 0.98	1.04 ±1.01	0.72 ±0.89	3.62	0.02[†]
WhatsApp	2.15 ± 1.22	2.48 ±1.17	2.35 ±1.28	1.49	0.22
MOH website	3.36 ±1.08	3.38 ±1.07	3.04 ±1.14	3.82	0.02[†]
Other sources	1.67 ±1.48	1.43 ±1.33	1.23 ±1.34	2.66	0.07

[†]Post Hoc Bonferroni test showed that: Twitter: University Student and Non-HCP ($P=0.001$); YouTube: HCP and Non-HCP ($P=0.044$), University Student and Non-HCP ($P=0.025$); Telegram: HCP and Non-HCP ($P=0.28$); MOH website: HCP and Non-HCP ($P=0.044$).

Using t-test, Table 7 showed that males were significantly relying on Facebook, Twitter, and YouTube more than female. Both male and female participants rely equally on Instagram, Telegram, WhatsApp, MOH website, and other sources like family, peers, news, and medical journals.

Table 7: Reliance on Social Media Sources for COVID-19 Awareness gender

Source	Male	Female	P-value
Facebook	1.03±1.11	.67±.85	0.005
Instagram	1.61±1.23	1.69±1.26	0.665
Twitter	2.43±1.23	1.96±1.43	0.017
YouTube	1.98±1.26	1.52±1.20	0.006
Telegram	.87±.89	.84±.97	0.812
WhatsApp	2.38±1.24	2.34±1.24	0.819
MOH website	3.43±.82	3.16±1.17	0.086
Other sources	1.43±1.29	1.37±1.39	0.780

DISCUSSION

The aim of the study was to investigate the main source of COVID-19-related information and the extent of social media attitudes during the pandemic in Saudi Arabia. During the COVID-19 pandemic, social media platforms have been playing a critical role in the dissemination of safety information, sharing public experience, and providing scientific clinical findings of treatment protocols. As the nature of COVID-19 is evolving and changing, public sources of information about the pandemic can be differently used among people. Creating public awareness through reliable sources can reduce the risk of infection and improve the quality of life in the community (Alanezi *et al.*, 2020). Additionally, disseminating information that is convenient and understandable by the public is key to increase awareness (Basch *et al.*, 2020).

The present study found that more than 54% reported that the MOH website is the main source for pandemic-related information, and 57% confirmed that they will always rely on it for awareness. This finding was anticipated as the Saudi MOH was among the first countries to implement massive precautionary measures in the early pandemic stages, which exceptionally reduced the number of new COVID-19 cases in the country (Alumran, 2020). Saudi MOH took a strong and proactive public health presence on social media; policies related to public health (quarantine, hand hygiene, social distancing, wearing masks, and avoiding gatherings of more than 50 individuals) have been widely posted in the MOH website. During COVID-19 pandemic, community safety and health were the highest priority of the Ministry of Health. Thus, lots of efforts were exerted to increase public awareness with different languages through MOH official website and official social media accounts such as Twitter. On Twitter, MOH posted an awareness video on COVID-19 pandemic. This video explained the safe daily practice and lifestyle to prevent the spread of COVID-19. Such as the way and importance of wearing a face mask outside the home and avoiding handshakes and maintaining social physical distancing while greeting other people (MOH News, 2020).

Furthermore, MOH launched a new website namely, COVID-19 awareness (<https://COVID-19awareness.sa/>); it is the leading health awareness platform that includes the daily statistics report on COVID-19 cases and different COVID-19 related topics like the use of the 937 hotline and self-assessment methods. This platform monitors all COVID-19 information and news published on all social media platforms. Besides, MOH established COVID-19 dashboard and other mobile applications to guide the public and improve their awareness such as Tabaud, Tawakkalna, and Tatamman. Tabaud (<http://tabaud.sdaia.gov.sa>) is an Arabic word meaning “keep away”. That is, uninfected person is notified to keep away from an infected individual. The Tabaud database stores all individuals who were infected with COVID-19. The main goal to track Coronavirus spread and inform users if they have contacted positive cases. The application enables users to receive notifications in case of any registered infected person has been detected in a nearby area. Tawakkalna is to facilitate the issuance of movement permits electronically during the curfew period and to support government efforts to limit the spread of COVID-19. Tatamman provides protection and health care for citizens and maintain their safety and enhance their recovery procedures. The Center for Disease Control and Prevention, the SaudiCDC (<https://COVID-19.cdc.gov.sa>), monitor, measure, evaluate, control, and prevent any risk factors related to the public health in Saudi Arabia. It provides many health services, but not limited to:

- Conducts research and studies related to the public well-being.
- Monitors diseases on national and international levels.

- Exchanges health information with international health organizations.
- Acts as a national resource for detection and diagnosis of diseases.
- Cooperates with national and international centers and authorities for the promotion of wellness and the prevention and control of diseases.
- Supervises health awareness and health education programs in the field of public health.
- Encourages and maintains legislation that promotes wellness and limits the spread of unhealthy habits

SaudiCDC developed an interactive dashboard updated daily. It reports the national and international COVID-19 statistics such as the total reported cases, active cases, dead and recovered cases. All available information and guidelines on MOH website and its official social media channels are evidenced-based and updated regularly. Thus, the MOH website was the most used and trusted source for COVID-19 related information in Saudi Arabia.

Findings showed that the second and third most popular social media sources used for COVID-19-related information were WhatsApp and Twitter. During the quarantine, many people were confined to their phone applications for social and knowledge exchange. This was expected, as even HCP themselves have been using WhatsApp and Twitter for real-time professional communication and debate related to the pandemic. However, there have been instances where lack of consensus of opinion among physicians, have raised public fear and uncertainty (Haroon, 2020).

The study found that the participants regardless of their gender, reported different social media attitudes. They were always finding COVID-19 videos on social media. This is supported by a new study conducted Basch et al. (2020). They found that more than 165 million persons viewed 100 YouTube videos under the word "coronavirus". Furthermore, the study showed a significant relation between the study groups and obtaining useful COVID-19 social media information. The study showed that healthcare providers were the most group sharing COVID-19 content and attending online COVID-19 lecture. This wisely way of using social media platforms leads to improve individuals and public health. Healthcare providers use social media tools for professional development, sharing different educational materials, policies and healthy behaviors with colleagues and public. Physicians are attending online committees to listen to new articles and new and consult other experts about a specific patient's illness.

Thus, it is important that the public relies on a verified source of information, such as the government, because unverified sources are vulnerable to false acquisitions. Ambiguity about COVID-19 can cause a deluge of misinformation to be easily spread on SM applications. Among International Students, 20% encountered false news about COVID-19 from Facebook, Twitter and weChat (Ong'ong'a, & Demuyakor, 2020). In Iran, hundreds died after drinking methanol alcohol that social media messages said had cured COVID-19 patients (Iranpour *et al.*, 2020). In other countries, rumors spread on social media about food and medication scarcity drove people to stock extra supplies, which fluctuated the price of products and caused actual shortages (Zarocostas, 2020). The dissemination of exaggerated information can cause fear, stress, and/or anxiety which can increase the risk for other poor health outcomes at a time where not overbearing the healthcare system is especially important. For example, SM messages about the non-availability of vaccine, ineffective antiviral drug against COVID-19, and that social distancing and isolation are the only option to be protected from infection, can make people vulnerable to mental health issues and/or suicidal thoughts (Thakur *et al.*, 2020). When the Severe Acute Respiratory Syndrome (SARS) spread in Asia, post-traumatic stress disorder (PTSD) was the most predominant psychiatric event appeared after the epidemic (Mak *et al.*, 2009).

As seeking information from SM is considered a new trend, coordinating and developing guidelines for responsible use should be a top priority to ensure proper use (Frederick & Run, 2018; González-Padilla *et al.*, 2020). Governments are encouraged to direct the public toward the credible sources of information. In addition, engaging professional participation in enriching the SM content is important to reduce the risk of incorrect or improper information in the digital world.

LIMITATIONS

To the author's knowledge, this study is the first in Saudi Arabia to assess the role of social media in creating awareness during the COVID-19 pandemic across groups of university students, healthcare professionals, and the public. However, while the results are only generalizable to the population in Saudi Arabia, and may not be applicable to people in different countries or different social and culture context, they may be relevant to other Gulf Cooperation countries. Additionally, the study explored social media attitudes and use during the month of October 2020 only. This duration may not reflect SM extent of use and attitudes to seek information in the initial days of the pandemic.

CONCLUSION AND RECOMMENDATION

This study has confirmed that the main source of information for COVID-19 awareness in Saudi Arabia is the Ministry of Health website. Although other social media sources of information were used, the public heavily relied on the MOH website for awareness during the pandemic. It is very important to have this reliable and trustworthy relationship between the public and MOH, which empower the community to combat misleading or fake information disseminated through the SM. The findings have important practical implications as this study addressed the public social media attitudes in information seeking

and sharing during the pandemic. It is recommended that policymakers and public health leaders develop and maintain effective and reliable SM channels for public health awareness. It is also recommended that governments support appropriate use of social media for all levels in the community. Future development of social media policies, social media monitoring tools, and professional content creation are required for public health awareness during pandemics.

REFERENCES

- [1] Alahdal, H., Basingab, F. & Alotaibi, R. (2020). An analytical study on the awareness, attitude and practice during the COVID-19 pandemic in Riyadh, Saudi Arabia. *Journal of Infection and Public Health*, 13(10), 1446-1452.
- [2] Alanezi, F., Aljahdali, A., Alyousef, S., Alrashed, H., Alshaikh, W., Mushcab, H., & Alanzi, T. (2020). Implications of Public Understanding of COVID-19 in Saudi Arabia for Fostering Effective Communication Through Awareness Framework. *Frontiers in public health*, 8, 494. doi: 10.3389/fpubh.2020.00494
- [3] Alumran A. (2020). Role of Precautionary Measures in Containing the Natural Course of Novel Coronavirus Disease. *Journal of Multidisciplinary Healthcare*, 13, 615-620.
- [4] Al-Dmour, H., Masa'Deh, R., Salman, A., Abuhashesh, M., & Al-Dmour, R. (2020). Influence of Social Media Platforms on Public Health Protection Against the COVID-19 Pandemic via the Mediating Effects of Public Health Awareness and Behavioral Changes: Integrated Model. *Journal of Medical Internet Research*, 22(8):e19996.
- [5] Alqahtani, A. S., Rashid, H., Basyouni, M. H., Alhawassi, T. M. & Bindhim, N. F. (2017). Public response to MERS-CoV in the Middle East: iPhone survey in six countries. *Journal of Infection and Public Health*, 10(5), 534-540. doi:10.1016/j.jiph.2016.11.015
- [6] Basch, C. H., Hillyer, G. C., Meleo-Erwin, Z. C., Jaime, C., Mohlman, J. & Basch, C. E. (2020). Preventive Behaviors Conveyed on YouTube to Mitigate Transmission of COVID-19: Cross-Sectional Study. *JMIR public health and surveillance*, 6(2), e18807.
- [7] Clement, J. (2020). Number of social media users 2025. Retrieved from <https://www.statista.com/statistics/278414/number-of-worldwide-social-network-users/> (accessed 30 October 2020)
- [8] González-Padilla, D. & Tortolero-Blanco, L. (2020). Social media influence in the COVID-19 Pandemic. *International Brazilian Journal of Urology*, 46(Suppl 1), 120-124.
- [9] Kemp, S. (2020). *Digital 2020 - Saudi Arabia*. Retrieved from <https://datareportal.com/reports/digital-2020-saudi-arabia>, (accessed 11 November 2020)
- [10] Haroon N. (2020). Physicians tackle COVID-19 on Social Media. *BC Medical Journal*. Retrieved from: <https://bcmj.org/blog/physicians-tackle-covid-19-social-media> (accessed 11 November 2020).
- [11] Iranpour P, Firoozi H. & Haseli S. (2020) Methanol poisoning emerging as the result of COVID-19 outbreak; radiologic perspective. *Academic Radiology*. 27(5), 755–756.
- [12] Kaicker J., Dang W. & Mondal T. (2013) Assessing the quality and reliability of health information on ERCP using the DISCERN instrument. *Health Care Current Reviews* 1(1), 104. doi: 10.4172/2375-4273.1000104
- [13] Mak IW, Chu CM, Pan PC., Yiu MG. & Chan VL. (2009). Long-term psychiatric morbidities among SARS survivors. *General Hospital Psychiatry*. 31(4), 318-326.
- [14] MOH News - MOH Publishes Awareness Video on Best Practices for COVID-19 Prevention. Retrieved from www.moh.gov.sa website: <https://www.moh.gov.sa/en/Ministry/MediaCenter/News/Pages/News-2020-06-07-003.aspx> (accessed 20/11/ 2020).
- [15] Nirajan (2020). 12 Advantages and Disadvantages of Social Networking Sites. Retrieved from <https://honestproscons.com/social-networking-advantages-and-disadvantages/> (accessed 6 October 2020).
- [16] Ong'ong'a, D. & Demuyakor, J. (2020). Coronavirus Infodemic in the Social Media: A Survey of Kenya International Students in China. *New Media and Mass Communication*, 90, 23-34. DOI: 10.7176/NMMC/90-03
- [17] Samet, A. (2020). How the Coronavirus Is Changing US Social Media Usage. Retrieved from <https://www.emarketer.com/content/how-coronavirus-changing-us-social-media-usage> (accessed 11 November 2020)
- [18] Tonsaker, T., Bartlett, G., & Trpkov, C. (2014). Health information on the Internet: gold mine or minefield?. *Canadian Family Physician*, 60(5), 407-408.
- [19] Thakur V. & Jain A. (2020). COVID 2019-suicides: A global psychological pandemic. *Brain Behavior Immunity*. 88, 952-953.
- [20] Watson, A. (2020). Topic: Coronavirus impact on global media consumption. Retrieved from <https://www.statista.com/topics/6134/coronavirus-impact-on-media-consumption-us/> (accessed 19 October 2020).
- [21] Zarocostas, J. (2020). How to fight an infodemic?. *The Lancet*, 395(10225), 676.

APPENDIX: Study Questionnaire

Dear Respondent, Greetings!

Thank you for taking the time for responding to this questionnaire.

It will take approximately 5 minutes of your time but would be a great help in achieving the goal of our research (to study the role of social media in creating awareness during COVID-19 pandemic in Saudi Arabia). I would like to assure you that all information provided will be kept completely confidential and will only be used for the purpose of the research.

Section 1: Demographic and General Questions:

1. Gender: Male Female
2. Age: _____
3. Education: Middle School or less High School Certificate or Diploma
 Bachelor degree Graduate studies
4. Nationality: Saudi citizen Resident of Saudi Arabia
5. Geographic Region of residence: Eastern Western Middle Southern Northern
6. Which of the following best describes you?
 University Student Healthcare Professional Non-Healthcare Professional

Section 2: COVID-19-related Questions:

11. Are you worried to be infected with COVID-19? No Yes
12. Have you been diagnosed with a positive COVID-19 transmission? No Yes
13. Have you ever isolated yourself as a precaution or because you suspected to be infected by COVID-19? No Yes
 (if yes, how many days did you isolate yourself? _____)
14. Where do you get most information regarding COVID-19?
 Facebook Instagram Twitter YouTube
 Telegram WhatsApp MOH website Other: specify _____

Section 3: Attitudes during COVID-19 Pandemic:

1. How often do you find videos, articles and blogs on social media talking about COVID-19?	<input type="checkbox"/>	<input type="checkbox"/>	<input type="checkbox"/>	<input type="checkbox"/>	<input type="checkbox"/>
	Always	Often	Sometimes	Rarely	Never
2. How often do you follow pages, profile, vlogger or blogger providing information regarding COVID-19?	<input type="checkbox"/>	<input type="checkbox"/>	<input type="checkbox"/>	<input type="checkbox"/>	<input type="checkbox"/>
	Always	Often	Sometimes	Rarely	Never
3. How often do you share content regarding COVID-19 through social media?	<input type="checkbox"/>	<input type="checkbox"/>	<input type="checkbox"/>	<input type="checkbox"/>	<input type="checkbox"/>
	Always	Often	Sometimes	Rarely	Never
4. How often do you attend online lectures/symposium related to COVID-19 organized by professional organization?	<input type="checkbox"/>	<input type="checkbox"/>	<input type="checkbox"/>	<input type="checkbox"/>	<input type="checkbox"/>
	Always	Often	Sometimes	Rarely	Never
5. How often do you think that information regarding COVID-19 on social media are important?	<input type="checkbox"/>	<input type="checkbox"/>	<input type="checkbox"/>	<input type="checkbox"/>	<input type="checkbox"/>
	Always	Often	Sometimes	Rarely	Never
6. How often do you apply the information received from social media about COVID-19?	<input type="checkbox"/>	<input type="checkbox"/>	<input type="checkbox"/>	<input type="checkbox"/>	<input type="checkbox"/>
	Always	Often	Sometimes	Rarely	Never

Section 4: Reliance on Social Media Sources

How often do you rely on information related to COVID-19 in the following social media sources?

Facebook	<input type="checkbox"/>	<input type="checkbox"/>	<input type="checkbox"/>	<input type="checkbox"/>	<input type="checkbox"/>
Instagram	<input type="checkbox"/>	<input type="checkbox"/>	<input type="checkbox"/>	<input type="checkbox"/>	<input type="checkbox"/>
Twitter	<input type="checkbox"/>	<input type="checkbox"/>	<input type="checkbox"/>	<input type="checkbox"/>	<input type="checkbox"/>
YouTube	<input type="checkbox"/>	<input type="checkbox"/>	<input type="checkbox"/>	<input type="checkbox"/>	<input type="checkbox"/>
Telegram	<input type="checkbox"/>	<input type="checkbox"/>	<input type="checkbox"/>	<input type="checkbox"/>	<input type="checkbox"/>
WhatsApp	<input type="checkbox"/>	<input type="checkbox"/>	<input type="checkbox"/>	<input type="checkbox"/>	<input type="checkbox"/>
MOH website	<input type="checkbox"/>	<input type="checkbox"/>	<input type="checkbox"/>	<input type="checkbox"/>	<input type="checkbox"/>
Other sources	<input type="checkbox"/>	<input type="checkbox"/>	<input type="checkbox"/>	<input type="checkbox"/>	<input type="checkbox"/>

Thank you for your participation in this study.

The Impact of Employment Discrimination on Job Search Performance

(Full paper)

Xintong Liu, Hohai University, China, 531030981@qq.com

Qiong Jia*, Hohai University, China, jiaqionghit@163.com

Longhui Li, Hohai University, China, 1051340778@qq.com

ABSTRACT

This study is to explore the impact of perceived employment discrimination on job search performance. Based on the trait activation theory, this article proposes that people's perceived employment discrimination when searching jobs online has a direct effect on job search performance, moderated by self-efficacy of job applicants. A total of 97 valid questionnaires were collected in this study. Through data analysis, we have concluded that the perceived impact of employment discrimination on job search performance is significantly negatively correlated, and job applicants' self-efficacy is not significant. Such results have implications for the human resource managers and job applicants to adopt positive attitudes to deal with the possible facing discrimination generated during searching a job in the internet era.

Keywords: Perceived employment discrimination, job search performance, self-efficacy

*Corresponding author

INTRODUCTION

In the current era of Internet job hunting, based on the convenience and development of the Internet, online job hunting has gradually accounted for an increasing proportion of fresh graduates. From the perspective of the relationship between total supply and total demand, the number of laborers usually exceeds the number of demands, which will inevitably intensify competition for employment pressure. There are currently more than 2,000 colleges and universities and the only a few are highly recognized by the society. This phenomenon will inevitably cause graduates of key colleges and non-key colleges to suffer in the talent market. To treat the problem differently, the perceived employment discrimination factor that people perceive may become one of the important factors affecting job search behavior and results (hereinafter will be more precisely expressed as "job search performance"). At present, domestic and foreign scholars have different degrees of research on people's perception of employment discrimination, job search performance and job self-efficacy. However, there are few studies conducted from the perspective of the impact of perceived employment discrimination on job search performance. Therefore, this study reveals how the self-efficacy factor of job applicants play a role in the chain of causality between perceived employment discrimination and job search performance. It can also theoretically occupy the dominant professional competition market in online job search, and provide guidance for job seekers, especially graduated college students.

LITERATURE

Perceived Employment Discrimination

In the "Convention and Recommendation on Discrimination in Employment and Occupation" (Convention No. 111), the International Labor Organization has given a more standardized definition of "perceived discrimination in employment" (Reskin, 2000): Anything based on race, color, gender, religion, political views, ethnicity, ancestry, or social origin make distinctions, exclusions or preferences; the result is cancellation or damage to equal opportunities or equal treatment in employment or occupation, thus constituting people's perceived discrimination in employment. The U.S. Equal Employment Opportunity Commission (the US ESOC) puts forward another concept—employment discrimination (Ragins & Cornwell, 2001; Volpone & Avery, 2013), that is, individuals are affected by factors such as race, color, nationality, gender, age, etc. in the organization's recruitment, training, salary design and distribution, and promotion.

At present, scholars have some differences in their understanding of perceived employment discrimination. The first is reflected in the naming of the concept of perceived employment discrimination. Some scholars directly name it as employment discrimination, and some scholars name it as perceived employment discrimination. But there is no obvious difference between the two names. In order to better describe it below, we will uniformly use perceived employment discrimination as the name of this phenomenon. Hebl et al. (2002) divided discrimination in organizational contexts into explicit discrimination (Robinson & Wunnava, 1989; Doyle, 2007) and interpersonal discrimination; Hidden discrimination refers to the voluntary or involuntary negative behaviors of the members of the organization in the communication process, which are not inconsistent with the law and job responsibilities, and generally consist of verbal, nonverbal (such as body language) or language-like behavior. In organizational situations, it often manifests as a lack of smile and encouragement, and even hostility. Research shows that interpersonal discrimination is widespread in daily work and life, and interpersonal discrimination is often manifested through discrimination perception. Explicit discrimination usually occurs in links such as employment and career development. It is expressly prohibited by law and is generally correct for various social norms. The visibility and measurability of explicit discrimination is stronger than implicit discrimination. In addition, Dovidio and Gaertner proposed the concepts of blatant

discrimination and subtle discrimination. Yao He and others believe that there are two basic forms of employment discrimination that people perceive namely direct discrimination and indirect discrimination. These three categories actually have their inherent similarities.

To make discrimination tangible, the measurable medium of discrimination perception must be eliminated. Discrimination perception refers to the experience that an individual perceives in a certain group or environment that he is treated differently compared to other members. In recent years, the measure of discrimination has been gradually replaced by self-reporting by implicit measurement. For example, Ziegert and Hanges (2005) used the Implicit Association Test (IAT) (Kim, 2003) to evaluate the implicit racial attitudes of the subjects by examining the two indicators of reaction time and error rate during the process of classifying words. Implicit measurement can more effectively avoid self-reporting bias and is therefore more suitable for evaluation bias.

Job Search -Performance

Performance is the collective term for performance and efficiency, which includes both the efficiency in the process and the results of activities. The focus of this study is on the job search performance of individual graduates. The difference from previous studies is that it focuses more on individuals rather than groups. However, job search performance for individuals at home and abroad is much less than that for groups. Job search performance refers to the performance and efficiency of the job search process (Ellis & Taylor, 1983) and the performance and efficiency of the job search process. Previous job search performance studies mostly only considered the variable of employment as a measurement dimension. It is not scientific and reasonable to determine the job search performance by simply measuring whether an individual can be employed. Since the 1980s, scholars have expanded the depth and breadth of job search performance research to increase job satisfaction, and degree of influence. Job search performance has two dimensions: obtaining performance and continuous performance (Somers & Birnbaum, 2000). Obtaining performance refers to the smoothness of obtaining a job. Continuous performance refers to the length of time in the job after obtaining the job, which involves the degree of satisfaction with the job itself. The focus of this study is on the job search performance of individual graduates. With reference to the current research on factors affecting job search performance by domestic and foreign scholars (Sheehan, McDevitt & Ross, 1998; Jaramillo, Mulki & Solomon, 2006), the factors affecting job search performance mainly include the following aspects: The first thing are subjective attributes of individual characteristics. The second thing is the professional ability. Students with stronger professional ability are easier get a job position you like; intensity of job search; job search performance of graduates is positively correlated with personal effort. The third thing are environmental factors. Graduates from rural areas may be restricted by family conditions and other factors. They tend to have lower job search expectations than graduates from cities, so they are more likely to get a job; from this, it can also be found that the environment is affecting the individual's professional values, in turn, will affect subsequent job search behavior and job performance.

Self-efficacy

The theory of self-efficacy was first proposed by Albert Bandura (1977). He believes that self-efficacy is a belief, which is an individual's ability to achieve a certain goal. The degree of confidence is also the gap between the individual's perception of the various aspects of the condition and the selected goal. Bandura divides self-efficacy into three dimensions: difficulty, intensity, and integrity. Difficulty refers to the individual's predictive value of the difficulty of a certain task to be completed, intensity refers to the degree to which the individual can persist in self-efficacy when facing difficulties, and integrity refers to the degree of transferability of the individual's self-efficacy. These three dimensions are a good measure of whether an individual can maintain confidence in himself in adversity. Bandura also believes that individuals tend to avoid activities beyond the scope of their ability, and are willing to do things within their ability. In addition, individuals will refuse activities that they can accomplish due to lack of confidence. Above, the individual's self-efficacy is related to its behavior, self-efficacy can guide individual actions. Hackett and Betz (1995) first introduced the concept of self-efficacy to the field of job hunting in 1981 (Renn & Fedor, 2001), trying to interpret the relationship between the proportion of women in high-income groups and self-efficacy. Since then, the research field has expanded to all aspects of career fields such as decision-making, career development, and job search behavior. In this research, what we call self-efficacy focuses on the individual's confidence in completing specific tasks or behaviors, and mainly controls the attitude of the subjects when facing difficulties, and the self-evaluation of their own abilities. This pre-evaluation will affect the subsequent behavior in many ways. It may influence people's choice of behavior, affect the persistence and effort in the face of difficulties or affect people's behavior and emotional state.

The existing measurement methods for self-efficacy can be divided into two categories: one is the measurement of general self-efficacy; the other is the measurement of self-efficacy in specific fields. Bandura believes that the measurement and analysis of individual self-efficacy should be analyzed in detail, and should be placed in the environment formed by specific work and corresponding behavior. When the work content or the surrounding environment changes, the individual's self-efficacy will also change. The measurement of self-efficacy in a specific field represented by Bandura is aimed at a specific field and needs to be implemented in combination with a specific situation and field. Regarding the measurement of job-seeking self-efficacy, it can be traced back to the job-seeking self-efficacy questionnaire in 1985. The content of the questionnaire mainly includes the self-efficacy of individuals looking for jobs and vacancies. These scales are divided into three categories: the first category is a one-dimensional job search self-efficacy questionnaire, which only explores a certain

aspect of self-efficacy, and only uses high or low self-efficacy as the standard. The second category is a two-dimensional job search self-efficacy questionnaire, and the third category is a multidimensional self-efficacy questionnaire.

Fairness heuristic theory

The overall sense of fairness affects people's attitudes, emotions, and behaviors. Once treated fairly, people will lay down their burdens and work hard to maximize the benefits of the organization. If personal interests conflict with the interests of the organization, individuals will sacrifice their personal interests to protect the interests of the organization. The core content of fairness heuristic theory can be summarized as two stages and three effects.

(1) The formation stage of fair judgment.

Lind and van den Bos (20021) believe that fair judgments also have this tendency. People will use the fairness information they are exposed to heuristically help people make fair judgments, reduce cognitive complexity, and improve judgment efficiency. Especially when people are in a state of lack of information or ambiguity, people are more likely to use the fairness-related information which they have obtained from the situation to explain the overall fairness perception of the situation they are in.

(2) The use stage of fairness judgment.

When the overall sense of fairness is formed, people will use the overall sense of justice as a kind of enlightening information to guide and explain the related fairness information that they encounter later, that is, once the overall fairness judgment is made, this judgment itself will also produce other fairness judgments. influences. More importantly, this overall sense of fairness affects people's subsequent attitudes, emotions, and behaviors. Once treated fairly, people will work hard to maximize the benefits of the organization. If personal interests conflict with the interests of the organization, individuals will sacrifice their personal interests to protect the interests of the organization. In this way, the sense of fairness is used as an inspiration, and is connected with trust, cooperation, acceptance of authority and rules, self-esteem, pro-social behavior, and organizational citizenship behavior. On the contrary, if they think they have not been treated fairly, they will pay more attention to their personal interests, calculate carefully according to the return of personal short-term interests, and do things that are beneficial to the individual, and do not do things that are beneficial to the organization but not to the individual.

(3) Main cause effect.

The main cause effect is that a person is more receptive to early fair information and gives higher weight. The empirical research of van den Bos et al. (1998) support this view. Their research shows that: the information about procedural fairness and the information about distribution fairness, whichever gets the subjects first, has the greatest impact on fairness judgment, while the other has less influence.

(4) Substitution effect.

The fairness heuristic theory believes that when individuals collect fair information to form an overall fair judgment, the source of information may be result information, program information, and information about interaction with leaders, corresponding to result fairness, procedure fairness, and interaction fairness, respectively.

The research results of van den Bos et al. (1998) show that in the absence of judgments of fairness of results, judgments of procedural fairness will make up for this vacancy and form an alternative judgment of fairness of results. Of course, if there is information on the fairness of the results, the procedural fairness information will have less effect on the judgment of distribution fairness.

(5) Other effects.

Lind and van den Bos (20021) believes that the sense of fairness mainly affects the attitudes and behaviors related to the organization, while those that have little or nothing to do with the organization, it is not so easy to be affected by a sense of fairness.

MODEL

Whether the situation affects the individual is mainly due to how the situation is perceived by the individual. Mischel, Coates, and Raskoff, (1968) and Tett and Burnett (2003) proposed that the different personality traits of the individual are activated in different organizational contexts, so that the advantages of the personality traits are reflected in the work performance. This theory provides a perspective to explain why individuals with certain characteristics can predict performance better than others, and why individuals with certain characteristics can predict performance positively in some jobs, but negatively predict performance in other jobs performance. Therefore, when people feel discrimination, they will be stimulated to have different feelings. This perception may have an impact on job search performance. In addition, people with different self-efficacy may have different effects. As shown in Figure 1, in the research on people's perception of employment discrimination, numbers reflect the degree of perception of employment discrimination that job applicants perceive in the process of job hunting, so as to better measure individual differences. For job-seekers' self-efficacy, a quantitative concept is also introduced, job-seeking self-efficacy, which presents the degree of job-seekers' self-efficacy perception.

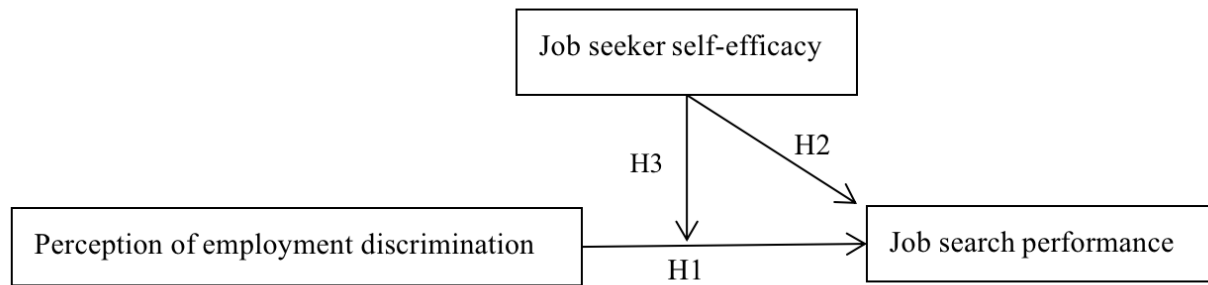

Figure 1: Research Framework

HYPOTHESIS

H1: People's perception of employment discrimination is correlated with job search performance.

The individual's perception of the situation affects the individual's behavior (Mischel, Coates & Raskoff, 1968). The starting point of this hypothesis is that in the process of job hunting, the level of discrimination perception will directly affect job seekers' behavior. That is to say, the stronger the discrimination perception of job applicants, the more sensitive the mind of the job applicant, the more he will be more concerned, and the less self-confidence in themselves, which will increase the difficulty of job hunting by multiples, which will affect the performance of job seekers in the job search process, such as the mistakes caused by the lack of confidence in the interview, or the job seekers will magnify the difficulty of job hunting and evolve into passive avoidance, that is, avoid job hunting behaviors and fear that the job hunting will happen, which will affect the job seekers job search the number of attempts greatly reduces job search performance and directly lead to employment failure.

H2: There is a positive correlation between job applicants' self-efficacy and job performance.

The self-efficacy of job-seekers, that is, the degree of confidence or belief that job-seekers have in their job-hunting activities during the job-hunting process. This inner activity is manifested through external behaviors. The job-seeking behaviors of job seekers driven by feelings will be different, and the final result will be different. If you have a strong sense of self-efficacy, you will be more courageous and proactive in the job search process, and will not easily shrink back in the face of failure. If you have a weak sense of self-efficacy, the opposite is true.

H3: Job-seekers' self-efficacy has a moderating effect on people's perception of employment discrimination and job search performance.

People's perceived employment discrimination will affect job search performance, and job seekers' self-efficacy can also affect job search performance. Then when considering that people's perceived employment discrimination will affect job search performance, the self-efficacy of job seekers may play a certain role between the two, that is, this hypothesis is considered to play a moderating role. When job seekers have a strong sense of discrimination in employment, a series of problems such as the lack of confidence and withdrawal may appear. Job seekers with a strong sense of job-seeking self-efficacy can overcome such problems as the lack of confidence and withdrawal. Then when job seekers feel discrimination in employment, because job search self-efficacy is high or low, it is possible to reduce or increase the effect of job search performance. In summary, a strong sense of self-efficacy of job seekers will reduce the impact of employment discrimination on job search performance, and vice versa, it will reduce the impact.

DATA

This questionnaire survey was conducted online and a total of 106 questionnaires were collected, including 97 valid questionnaires. This questionnaire is mainly distributed to senior seniors who have obtained at least one offer. Among them, in terms of gender, women account for 55% and men account for 45%. In terms of schools, 211/985 key college graduates accounted for 35%, and ordinary college graduates accounted for 65%. From the perspective of household registration sources, about 40% are from rural areas, 50% are from small towns, and about 10% are from big cities. In terms of age, the samples in this survey are all between 20 and 25 years old. People's perception of employment discrimination has a total of 20 questions, the sample size is 97, and the final reliability coefficient is 0.722. This coefficient indicates that the reliability of the questionnaire is within an acceptable range. There are 10 questions in the job-seeking self-efficacy questionnaire, and the final reliability coefficient is 0.841, which is higher than 0.8, indicating that the questionnaire has good reliability. Finally, the reliability coefficient of the job search performance questionnaire is 0.761, which is between 0.7-0.8 The reliability is within the acceptable range and can be used for research and measurement.

MEASUREMENTS

This study will use three sets of scales to synthesize a set of questionnaires. The three sets of scales are: Employment Discrimination Perception Measurement Scale, Job Seeker Self-Efficacy Measurement Scale, work performance measurement Scale. The Employment Discrimination Perception Scale involves seven aspects to measure the perception of employment discrimination: school, gender, appearance, major, household registration, experience, and height. Set up questions for different aspects of employment discrimination, and use the five-point weighting method to measure the perception of employment discrimination. The Self-Efficacy Scale for Job Seekers is adapted from the General Self-Efficacy Scale (GSE), which has good aggregation and resolution. This questionnaire design is based on the general self-efficacy scale, fully considers the relevant context of the job search process, and adds relevant contextual assumptions to quantify the self-efficacy of job applicants. The work performance measurement scale refers to the four-item job-seeking self-efficacy questionnaire compiled by Kenfer in 1985 (Strauser & Berven, 2006). The content of the questionnaire mainly includes what kind of job an individual is looking for, finding vacant positions, etc. Sense of efficacy. The measurement of discrimination has been gradually replaced by implicit measurement by self-report. For example, Ziegert and Hanges used the Implicit Association Test (IAT) (Kim, 2003) to categorize words by examining the two indicators of reaction time and error rate to evaluate. The questionnaire will simply set up 6 questions. The six questions belong to two levels. The first level is to explore process performance, mainly involving the first two issues, and the second level is to explore result performance, including the last four issues. According to two dimensions, the answer to each question also has five levels ranging from "completely inconsistent" to "completely conforming", "completely conforming" is recorded as 5 points, each level is decremented by 1 point, "completely not conforming" "Is counted as 1 point, and finally a questionnaire is made.

RESULTS

(1) People's perception of employment discrimination will directly affect job search performance.

Based on the previous theoretical assumptions, we believe that the strength of people's perception of employment discrimination will drive job-seekers to react differently, which in turn will affect the final job-hunting results. The reliability column can reflect that the final reliability coefficient of the Employment Discrimination Perception Questionnaire is 0.722, and the final reliability coefficient of the job seeker self-efficacy questionnaire is 0.841, which is higher than 0.8, indicating that the questionnaire has good reliability; The reliability coefficient is 0.761, between 0.7-0.8. The reliability is within the acceptable range and can be used for research and measurement. In summary, the final reliability of the three major questionnaires is higher than 0.7, which is within an acceptable range. Among them, the final reliability of the job-seekers' self-efficacy questionnaire is higher than 0.8, which has excellent reliability.

(2) The self-efficacy of job seekers will also directly affect job search performance.

Table1 Descriptive statistics and reliability test of the questionnaire results.

	Statistic s	Mean	Minimum Value	Maximum Value	Standard Deviation	Cronbach α
People's perception of employment discrimination	97	3.2036	2.35	4.20	0.3876	0.722
Job applicant self-efficacy	97	3.6062	2.50	5.00	0.5458	0.841
Job search performance	97	3.1529	1.00	5.00	0.7132	0.761

The scores of job search performance and job self-efficacy are all over 3 points. Preliminary judgment is that the subjects generally feel discriminated against in employment, but most of the subjects have strong confidence in their job search activities, and it also reflects that the subjects are satisfied with the job search results as a whole. In terms of standard deviation, the standard deviation of people's perception of employment discrimination is small, indicating that the difference in their sense of discrimination is not too large; the standard deviation of self-efficacy is moderate, which also varies from person to person. The standard deviation appears to be too large, indicating that some people are extremely satisfied with the job search results, and some are extremely dissatisfied, and there is a big difference.

(3) The self-efficacy of job seekers is not significant in the moderating effect of the perceived employment discrimination on job search performance.

Table 2 Regression analysis table with job search performance as the dependent variable.

Predictor variable	Standardization coefficient	P value
People's perception of employment discrimination	-0.521***	0.000*
Job search self-efficacy	0.228**	0.008
People's perception of employment discrimination * Self-efficacy in job hunting	-0.042	0.612

From the above figure, the regression coefficient between people's perceived employment discrimination and job search performance is -0.521 ($p < 0.01$), indicating that the impact of people's perceived employment discrimination on job search performance is significant and negatively correlated, Hypothesis 1 is verified. The regression coefficient between job search self-efficacy and job search performance is 0.228 ($P < 0.01$), indicating that there is a significant positive correlation between job search self-efficacy and job search performance. Hypothesis 2 is also true. The above figure shows that under the adjustment of job search self-efficacy, the regression coefficient between people's perceived employment discrimination and job search performance is -0.042 ($P > 0.05$), indicating that people's perceived employment discrimination affects job search performance in the process, the regulatory role played is not obvious. Hypothesis 3 has been verified by data and cannot be supported.

DISCUSSION

According to previous theoretical assumptions, people's perception of employment discrimination will drive job applicants to make different behaviors, which will affect the final job search results. At the same time, in the research of this article, job-seekers' self-efficacy is defined as the job-seekers' belief or confidence in their job-hunting activities. Through empirical research, it can be found that job-seekers' self-efficacy is related to the impact of perceived employment discrimination on job search performance. It plays a negative role, but it is of little significance. This may be due to the fact that in the process of employment discrimination affecting job search performance, the difference in performance between job seekers with high job-seeking self-efficacy and job seekers with low job-seeking self-efficacy is small or because the sample size of the questionnaire is limited. In the future, we hope to expand the sample size and accurate detailed information of the questionnaire, refine the questionnaire scoring method, and enhance the degree of data discrimination to obtain this accurate correlation. At the same time, I hope that scholars in follow-up studies will give more consideration to the combination of employment discrimination, job search performance and job self-efficacy.

CONCLUSION

According to the relevant research theories of scholars in recent years, this article discusses the impact of perceived employment discrimination on job search performance by issuing questionnaires and empirically. Through data analysis and analysis, we conclude that the impact of perceived employment discrimination on job search performance is significantly negatively correlated, the strength of the perception of employment discrimination will drive job-seekers to make different behaviors, which in turn will affect the final job-hunting results. The impact of perception of employment discrimination on job search performance is negatively correlated, that is, the stronger the perception of discrimination, the worse the job search performance. Conversely, the weaker the discrimination perception, the better the job search performance. And the self-efficacy of job applicants is not significant in moderating the impact of perceived employment discrimination on job search performance. It may be because of the influence of employment discrimination on job search performance, the difference in performance between job seekers with high job-seeking self-efficacy and job seekers with low job-seeking self-efficacy is smaller. This article suggests that job-seekers should be trained to modify their perception about the discrimination during the job hunting process, in order to exert their subjective initiative in the job search process and enhance their self-efficacy, which can lead to a better job search performance.

REFERENCES

- [1] Bandura, A. (2010). Self-efficacy. In *The Corsini Encyclopedia of Psychology* (4th Ed. pp. 1534-1536). Hoboken, New Jersey: John Wiley & Sons.
- [2] Doyle, O. (2007). Direct discrimination, indirect discrimination and autonomy. *Oxford Journal of Legal Studies*, 27(3), 537-553.
- [3] Ellis, R. A. & Taylor, M. S. (1983). Role of self-esteem within the job search process. *Journal of Applied Psychology*, 68(4), 632-640.
- [4] Hebl, M. R., Foster, J. B., Mannix, L. M. & Dovidio, J. F. (2002). Formal and interpersonal discrimination: A field study of bias toward homosexual applicants. *Personality and Social Psychology Bulletin*, 28(6), 815-825.
- [5] Jaramillo, F., Mulki, J. P. & Solomon, P. (2006). The role of ethical climate on salesperson's role stress, job attitudes, turnover intention, and job performance. *Journal of Personal Selling & Sales Management*, 26(3), 271-282.
- [6] Kim, D. Y. (2003). Voluntary controllability of the implicit association test (IAT). *Social Psychology Quarterly*, 66(1), 83-96.
- [7] Lind, E. A. & van den Bos, K. (2002). When fairness works: Toward a general theory of uncertainty management. *Research in Organizational Behavior*, 24, 181-224.
- [8] Mischel, W., Coates, B. & Raskoff, A. (1968). Effects of success and failure on self-gratification. *Journal of Personality & Social Psychology*, 10(4), 381-390.
- [9] Ragsin, B. R. & Cornwell, J. M. (2001). Pink triangles: antecedents and consequences of perceived workplace discrimination against gay and lesbian employees. *Journal of Applied Psychology*, 86(6), 1244-1261.
- [10] Renn, R. W. & Fedor, D. B. (2001). Development and field test of a feedback seeking, self-efficacy, and goal setting model of work performance. *Journal of Management*, 27(5), 563-583.
- [11] Reskin, B. F. (2000). The proximate causes of employment discrimination. *Contemporary Sociology*, 29(2), 319-328.
- [12] Robinson, M. D. & Wunnava, P. V. (1989). Measuring direct discrimination in labor markets using a frontier approach: evidence from CPS female earnings data. *Southern Economic Journal*, 56(1), 212-218.
- [13] Sheehan, E. P., McDevitt, T. M. & Ross, H. C. (1998). Looking for a job as a psychology professor? Factors affecting applicant success. *Teaching of Psychology*, 25(1), 8-11.
- [14] Somers, M. & Birnbaum, D. (2000). Exploring the relationship between commitment profiles and work attitudes, employee withdrawal, and job performance. *Public Personnel Management*, 29(3), 353-366.
- [15] Strauser, D. R. & Berven, N. L. (2006). Construction and field testing of the Job Seeking Self-Efficacy Scale. *Rehabilitation Counseling Bulletin*, 49(4), 207-218.
- [16] Tett, R. P. & Burnett, D. D. (2003). A personality trait-based interactionist model of job performance. *Journal of Applied Psychology*, 88(3), 500-517.
- [17] van den Bos, K., Wilke, H. A. & Lind, E. A. (1998). When do we need procedural fairness? The role of trust in authority. *Journal of Personality and Social Psychology*, 75(6), 1449-1458.
- [18] Volpone, S. D. & Avery, D. R. (2013). It's self defense: how perceived discrimination promotes employee withdrawal. *Journal of Occupational Health Psychology*, 18(4), 430-448.
- [19] Ziegert, J. C. & Hanges, P. J. (2005). Employment Discrimination: The Role of Implicit Attitudes, Motivation, and a Climate for Racial Bias. *Journal of Applied Psychology*, 90(3), 553-562. <https://doi.org/10.1037/0021-9010.90.3.553>

APPENDIX A : Measurements

Self-efficacy Questionnaire for Job Search	<ol style="list-style-type: none"> 1. If I try my best, I can always solve the problem. 2. Even if others oppose me, I can still get what I want. 3. For me, it is easy to stick to my ideals and achieve my goals. 4. I am confident that I can effectively deal with any unexpected events. 5. With my talents, I can deal with unexpected situations. 6. If I put in the necessary efforts, I will be able to solve most of the problems. 7. I can face difficulties calmly because I can rely on my ability to deal with problems. 8. When facing a difficult problem, I can usually find several solutions. 9. When I have trouble, I can usually think of some ways to deal with it. 10. No matter what happens to me, I can handle it with ease.
--	--

<p>Employment Discrimination Perception</p>	<ol style="list-style-type: none"> 1. Companies tend to recruit graduates from key universities. 2. I think graduates from key universities are more capable than those from ordinary universities. 3. I am very worried that the employer will decide whether to hire me based on the quality of the graduate school. 4. I cannot accept the gender restriction clause in the recruitment process. 5. I will affect my ability when applying for a job because of the company's gender restrictions. 6. The employment opportunities of girls are worse than that of boys. 7. I think people with good looks have an advantage in the job search process. 8. During the interview, I felt that my appearance had a degrading effect. 9. If your major is unpopular, it will be more difficult to find a job. 10. I regret choosing my current major, because I don't follow the employment situation. 11. If the position does not restrict my major, I will have more opportunities with my own ability. 12. I think students with local registered permanent residence will be more popular when companies are recruiting. 13. I will be rejected because the place of household registration is not in the same city as the applicant company. 14. If there is no household registration preference or discrimination, I would prefer to work in a city other than my hometown. 15. Companies always prefer graduates with relevant experience. 16. During the interview, I always feel that my experience is not as good as others. 17. Having relevant work or internship experience is directly related to the success rate of job hunting. 18. I think the disadvantage of my height is that I cannot make up for it in other ways. 19. I will try to make myself appear taller in the job search process. 20. I always feel that someone will discriminate against me because of my height.
<p>Job Search Performance</p>	<ol style="list-style-type: none"> 1. I am very active when looking for a job. 2. My job search is very smooth. 3. I quickly determined my work unit. 4. I have found the ideal job now. 5. I will stay in my current workplace as long as possible. 6. I think the job I am looking for is not much different from my expectations.

Research on the Influence of Pinduoduo Group-Buying Mode on Consumers' Impulse Buying

(Full Paper)

Jiali Cai, Sichuan Agricultural University, China, 18361072952@163.com

Xiaolin Li*, Sichuan Agricultural University, China, 57929606@qq.com

You Li, Sichuan Agricultural University, China, lieo12388@gmail.com

Sujuan Song, Sichuan Agricultural University, China, songsujuan9695@163.com

ABSTRACT

Social commerce, with its unique social attributes, has promoted the group-buying mode to become an important marketing tool. Based on the stimulus-organism-response (S-O-R) paradigm, this study constructs a research model of the impact of the social e-commerce platform Pinduoduo group-buying mode on impulse buying, and uses structural equation model (SEM) for empirical analysis. The research results show that under the group-buying mode: perceived price fairness and reciprocity have significant positive influence on satisfaction; source credibility and similarity have positive effects on trust. Trust is positively correlated with satisfaction. Trust significantly affects impulsive buying impulse, but satisfaction has no significant impact on impulsive buying impulse.

Keywords: Group-buying mode, impulse buying, S-O-R paradigm.

*Corresponding author

INTRODUCTION

With the increasing development of "Internet +" economic technology, e-commerce has gradually penetrated into our daily life, and media platforms with social properties have continued to be mobile and popularized (Zhang & Xu, 2019). In the context of the disappearance of traditional e-commerce traffic dividends and the rise of social e-commerce, the group-buying mode has gradually become a marketing means to urge consumers to buy impulsively through social interaction between people, among which Pinduoduo platform is the most representative. Pinduoduo platform stimulates consumers' sharing motivation by means of incentive measures, then uses its social resources to form social group-buying and guide group-buying mode to be listed successfully, achieving rapid development in a short period of time and creating commercial miracles. Group-buying mode quickly occupies the new retail market, followed by various platforms, among which the typical ones are "special price version" of Taobao and "jingxi", the group-buying APP of Jingdong, making the group-buying mode become the hot one at present.

The development of group-buying mode originated from Groupon group-buying website of the United States in 2008. During this decade, group-buying in China has experienced birth, decline and revival. Pinduoduo group-buying mode has successfully driven the rise of this mode (Sharma & Klein, 2020). The so-called group-buying refers to a social or collective online shopping community. Due to the aggregation of demand, a large number of consumers focus on buying the same commodity or service, resulting in a substantial price reduction. Not only the buyer gets preferential treatment, but also the seller can expand the customer base to increase product sales (Xiao, 2018). Since 2010, group-buying mode has presented an explosive development trend in China's consumer market with its advantages of low price and profit benefits (Han, 2012). However, along with its continuous development, online group-buying also has a series of problems such as lack of integrity and service quality (Han, 2012). At the same time, in the face of fierce market competition, some scholars have pointed out that the development of group-buying mode is increasingly assimilated and its user growth is gradually slow, so a new breakthrough point needs to be established -- constructing group-buying service scenario to stimulate consumers' purchase intention and thus increase their user stickiness (Gong & Liang, 2015). Pinduoduo mode is mainly composed of group-buying mode. Different from the unified discount price mode provided by traditional group-buying, Pinduoduo group-buying obtains discounts through independent group joining. With the continuous development of social e-commerce, the group-buying mode has been gradually improved. To be specific, Pinduoduo group-buying is a group-buying mode based on users launching group joining to their acquaintances through WeChat circle of friends, aiming to gather the power of more people, buy better products at lower prices and have more fun from it.

As for group-buying mode, most domestic and foreign scholars focus on the research on its own advantages and development (Chou, 2019; Han, 2012; Zheng & Zhang, 2018). Compared with a large number of studies on planned purchase behavior, there are relatively few studies on the antecedents of impulsive purchase from the perspective of online community and product recommendation (Chen et al., 2019; Zhang et al., 2019). Pinduoduo group-buying, as a successful paragon of group-buying mode, has rarely been studied on its impact on impulse buying. Therefore, the study of how Pinduoduo group-buying mode influences consumers' impulse buying is of great significance to both the academic and theoretical circles, and especially has important reference value for the future development trend of social e-commerce group-buying mode.

THEORETICAL FRAMEWORK AND LITERATURE REVIEW

Impulse Buying

Zafar *et al.* (2019) believed that impulse buying is an unplanned purchase, which is an instantaneous, intense and irresistible complex behavior that lacks cognitive deliberation and reflects a perceptual desire, which may be considered as a purchase intention without any prior planning. Stern (1962) gave full consideration to the influence of different stimulus factors and divided impulse buying into four types, namely pure impulse buying, suggestive impulse buying, reminder impulse buying and planned impulse buying. These four types of impulse buying have the common feature of being unrestrained (Zheng *et al.*, 2019). Since the actual impulse buying behavior is difficult to measure in a controlled environment, this study focuses on the impulse of consumer impulse buying. Chen *et al.* (2019) believed that the impulse buying impulse is a state of desire presented when exposed to environmental stimuli. Zafar *et al.* (2019) pointed out that several studies have shown that impulse buying impulse can replace the real impulse purchase behavior in social business environment, because consumers' impulse buying impulse largely leads to actual impulse buying. In the context of social commerce, social interaction between groups is becoming increasingly popular, and consumers are increasingly using social media platforms for information dissemination, which promotes purchase stimulation -- social factors have a greater impact and are more likely to lead to impulse purchase (Chen *et al.*, 2019).

S-O-R Paradigm

Liu, Li, and Hu (2013) pointed out that the stimulus-organic-response (S-O-R) framework developed based on environmental psychology has been widely used to explain impulse buying, and they believed that environmental stimulus would have a significant and inevitable impact on consumers' purchasing decisions. The S-O-R paradigm indicates that stimulation can induce individual perception and affect their response (Zheng *et al.*, 2019). Price, as the core competitiveness of Pinduoduo group-buying mode, satisfies the consumer demand of price-sensitive groups for low-priced products. Collective purchase can make each group member benefit materially or spiritually and realize true reciprocity. Pinduoduo group-buying link sharing mainly relies on WeChat circle of friends, so social relationship in circle of friends is the key to successful marketing, which ensures the credibility of information source and similarity between individuals to a certain extent. All of the above factors can be used as external stimuli affecting consumers' purchasing psychology (Chen *et al.*, 2019; Shiao & Luo, 2012; Tai *et al.*, 2012). Therefore, in this research model, we regard situational factors (perceived price fairness, reciprocity, source credibility and similarity) as stimuli that affect consumer satisfaction and trust.

The organism is an internal state of the individual, which is the perceptual psychology between stimulus and response, usually manifested as an emotional state and a cognitive state (Zheng *et al.*, 2019). In this study, we regard satisfaction and trust as organism factors, because satisfaction and trust are reflected as an individual's emotional state, representing an individual's experience feeling and trust emotion, and usually acted as positive psychological factors to promote consumers' impulse purchase, which is consistent with the conclusions of earlier studies (Bressolles, Durrieu, & Giraud, 2007; Chen *et al.*, 2019).

Response is considered as the reaction to perception of different situational factors, manifested as approach or avoidance behavior (Wang, Yao, & Ye, 2014). In impulsive purchase process, the consumer response has experienced two stages, the first stage is impulsive purchase impulse, and the second stage is the actual impulse purchase behavior. The experience of the first stage is the necessary basis for the occurrence of the second stage. Only when the impulsive purchase impulse is generated, can the actual impulse purchase behavior occur (Zheng *et al.*, 2019). Therefore, in this study, urge to buy impulsively is adopted as an individual response factor.

Structural Equation Modeling (SEM)

Structural Equation Modeling (SEM) is a statistical analysis method based on the covariance matrix of processing variables to analyze the hypothetical relationship between latent variables. It has been widely used in linear modeling in Management, Economics, Sociology, Psychology and other fields (Wang & Chen, 2020). Structural Equation Modeling is divided into measurement model and structural model, which can deal with the relationship between observed variables and latent variables, and between latent variables and latent variables at the same time. It is a kind of confirmatory model analysis. It needs to establish measurement model and structural model according to theory in advance, and then collect data for verification. This research uses AMOS 24.0 to verify and analyze the model.

RESEARCH MODEL AND HYPOTHESIS FORMATION

Perceived Price Fairness and Satisfaction

Konuk (2019), based on the equity theory and the principle of dual rights, regarded perceived price fairness as a reasonable, equitable and acceptable assessment and related emotion for the price of a given product. From the perspective of consumers, the author believed that the price level of products with perceived fair price can bring fair profits to merchants, and proved to be positively correlated with satisfaction. Price is often considered as the key factor affecting consumers' purchase intention. Consumers usually set an acceptable price range for a product based on the comparison of goods or purchase experience. Other conditions being the same, the lower the price, the easier it is for consumers to accept it, and the more impulse they will have to buy impulsively (Tai *et al.*, 2012). The fairer the price perception of the product is, the higher the cost performance evaluation will be, and the more satisfied the consumers will be. Consumers' willingness to buy products will be affected by their perceived price fairness, especially in group-buying. Pinduoduo is popular among consumers because of its low price advantage, especially among low-consumption groups in third-tier and fourth-tier cities. Pinduoduo platform has the advantage

that the price of its products is generally lower than the general group purchase price, which makes consumers satisfied. Therefore, the hypothesis is put forward:

Hypothesis 1. Perceived price fairness has a positive impact on consumer satisfaction.

Reciprocity and Satisfaction

Zhang *et al.* (2019) thought that reciprocity is a kind of voluntary and autonomous behavior. This behavior not only helps those who give help, but also helps other members in the virtual community who need help, and provides corresponding help according to their request. It also belongs to an equal social exchange behavior, namely individuals feel fair when exchanging information, experience and other contents in the community. In Pinduoduo group-buying, the price of products participating in the group purchase is significantly lower than that of single purchase. At this time, the participants feel the benefits of the price reduction; in the invitation assistance, the inviting party can get free or low price discounts, and the invited party can get the gratitude of the inviting party. The next role exchange will be helped by the inviting party in the same way. The gratitude of the other party can be regarded as a social reward, which brings satisfaction to people. The premise of an agreed group purchase is that all parties can benefit and members can achieve mutual benefit. Users who profit from each other through Pinduoduo online group-buying information and link sharing have a positive attitude towards participating in Pinduoduo group-buying, and satisfaction, as an attitude measure, has been confirmed by Shiao and Luo (2012) to be significantly positively affected by reciprocity. Therefore, the hypothesis is put forward:

Hypothesis 2. Reciprocity has a positive impact on consumer satisfaction.

Source Credibility and Trust

Source credibility as the subjective evaluation of information communicator's trust degree to the communication source in the process of information communication. Scholars at home and abroad generally agree that source credibility is a subjective perception of the public. In Pinduoduo group-buying mode, information comes from WeChat circle of friends. WeChat is usually a social platform for acquaintances, while acquaintances always maintain a high relationship strength. People with close relationships are often regarded as reliable and trustworthy. Pinduoduo group-buying is famous for its social sharing through WeChat circle of friends. The viral link sharing of Pinduoduo in WeChat circle of friends has made Pinduoduo widely spread. Therefore, reliable information sources can increase the trust of consumers. Filieri, Algezau, and McLeay (2015) pointed out that the credibility of information sources will affect consumers' trust in communication channels, and thus positively affect consumers' trust in products or businesses. Therefore, the hypothesis is put forward:

Hypothesis 3. Source credibility has a positive impact on consumer trust.

Similarity and Trust

Similarity means that there are common values and interests among individuals. In their study, Chen *et al.* (2019) defined similarity as the degree to which followers find interest or experience matching with official accounts. Individuals tend to pay more attention to people with similar attitudes, they tend to trust people who are similar to them, and have more confidence in similar trustees. Prior studies have shown that similarity among individuals affects the development of trust (Chen *et al.*, 2019). For example, Johnson and Grayson (2005) believed that similarity positively affects the emotional trust of consumers. Chen *et al.* (2019) pointed out that similarity is positively correlated with cognitive trust and emotional trust of recommenders. Similarity can shorten the psychological distance between independent individuals. People with common topics and similar interests may feel a closer connection with each other, which can effectively reduce the skepticism and uncertain attitude among people. Therefore, similarity will promote the enhancement of trust. As the main communication channel of Pinduoduo's link sharing, social circle already has its own group attributes to a certain extent, such as similar consumption preferences. In Pinduoduo group-buying mode, consumers tend to trust the initiator when they find similarities between the friends who invite them to group-buying and themselves. Therefore, the hypothesis is put forward:

Hypothesis 4. Similarity has a positive impact on consumer trust.

Satisfaction, Trust and Urge to Buy Impulsively

Trust and Satisfaction

Trust means that consumers in the online environment have full confidence in organizations or sellers, and consumers' trust will produce a good feeling for online shopping; while, satisfaction refers to a pleasant psychological state in which consumers' post-purchase experience meets or even exceeds their expectations. It can also be understood as a good experience in which consumers' needs are satisfied. Namasivayam and Guchait (2013) believed that when consumers lack quality control over products, they tend to pay more attention to the evaluation of trust on suppliers, which will affect consumers' satisfaction with transactions. Shiao and Luo (2012) pointed out that consumers' trust in merchants will have a significant positive impact on their satisfaction, and the stronger the trust, the higher the satisfaction of consumers. In Pinduoduo group-buying, consumers have a sense of trust due to the reliable information source and the similarity between the initiator and the recipient of the group purchase link. Such a strong sense of trust promotes consumers to have positive emotional response to the group purchase products, and then promotes consumers to have a sense of satisfaction. Therefore, the hypothesis is put forward:

Hypothesis 5. Trust has a positive impact on consumer satisfaction.

Satisfaction and Urge to Buy Impulsively

Bressolles, Durrieu, and Giraud (2007) proposed in their study that satisfaction, as a positive emotional state, can reduce rational resistance by stimulating self-indulgence so as to induce impulse buying. Therefore, they proposed that the more satisfied consumers are with online shopping visits, the more likely they will experience online shopping impulse. Self-runaway is the direct cause of impulse buying behavior. When consumers' instant feeling exceeds self-expectation, it will trigger self-runaway, which will lead to impulse purchase. Satisfaction can be used as a measure of exceeding self-expectation. Therefore, in his (her) research, satisfaction was regarded as a key factor to induce consumers' self-runaway, and further demonstrated that satisfaction positively affects consumers' impulse buying behavior. In Pinduoduo group-buying, when consumers evaluate the fair price of group-buying products and predict the benefits after purchase, they will have positive satisfaction with the products, thus increasing the probability of impulse buying behavior. Therefore, the hypothesis is put forward:

Hypothesis 6. Satisfaction has a positive impact on urge to buy impulsively.

Trust and Urge to Buy Impulsively

Chen et al. (2019) believed that emotional trust in recommenders can stimulate consumers' impulse purchase intention. In the virtualized situation, consumers are unable to directly experience the products, resulting in consumers' emotional attitudes have a significant impact on their consumption choices (Zhang, Lu, & Yan, 2017). Stern (1962) proposed that the simplicity and convenience of the purchasing decision-making process can significantly improve the possibility of consumers' impulse buying. Trust generally includes cognitive trust and emotional trust, which is a complex psychological state combining individual rationality and sensibility. Trust can reduce the cognitive effort in decision-making, and trust others can reduce the processing of information, reduce the perceived uncertainty in the purchasing process, and thus improve the decision-making efficiency. In Pinduoduo group-buying, when consumers determine that the information they receive is trustworthy and risk-free, especially for product links recommended by acquaintances with emotional trust basis, they may give up the deliberative stage such as careful review, thus simplifying the decision-making process and leading to the increase of impulse buying. Therefore, the hypothesis is put forward:

Hypothesis 7. Trust has a positive impact on urge to buy impulsively.

Based on the above discussion, Figure 1 shows the research model of this paper. Specifically, based on the S-O-R framework, we study how situational factors such as perceived price fairness, reciprocity, source credibility and similarity affect satisfaction and trust, as well as emotional factors -- the internal influence between satisfaction and trust, which ultimately leads to urge to buy impulsively.

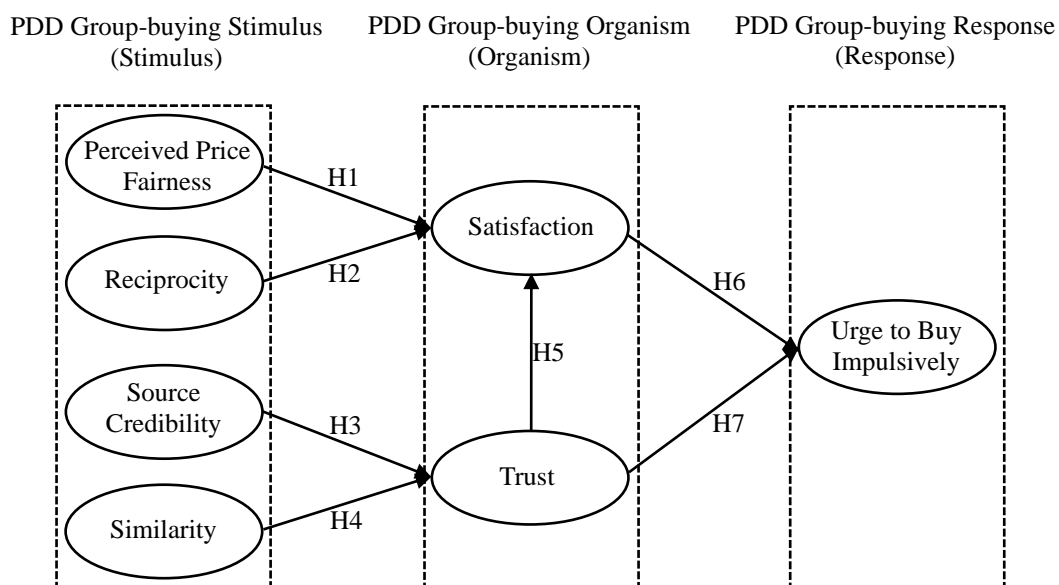

Figure 1: Research model.

RESEARCH METHODOLOGY

Measurement

The questionnaire designed in this study consists of two parts: The first part is the basic information of the respondents, involving: gender, age, education background and income; The second part is to measure all variables in the research model. These variable measure items are all derived from previous studies. For the sake of better adapting to the background of this research, we have made appropriate modifications to the variable items. These items were measured on a 7-point Likert scale (1= "strongly disagree" to 7= "strongly agree"). In order to ensure the validity of the questionnaire, we conducted a prediction test and analyzed the reliability and validity of the 100 valid questionnaires collected, and the analysis results were good. Finally, the wording, content and structure of the questionnaire were slightly modified according to the suggestions of professionals to further ensure the feasibility of the questionnaire. The questionnaire measurement items and their sources are shown in Table 1.

Table 1. Measurement items and sources of each variable.

Constructs	Item	Measure	Source
Perceived Price Fairness (PPF)	PPF1	The price of products is reasonable under the mode of Pinduoduo group-buying.	(Konuk, 2019)
	PPF2	The price of products is acceptable under the mode of Pinduoduo group-buying.	(Lu, Fan, & Zhou, 2016)
	PPF3	The price of products is competitive under the mode of Pinduoduo group-buying.	
Reciprocity (RE)	RE1	I find participating in Pinduoduo group-buying can be mutually helpful.	(Hsu & Lin, 2008)
	RE2	I find participating in Pinduoduo group-buying can be advantageous to me and others.	
	RE3	I think that participating in Pinduoduo group-buying can improve reciprocal benefit.	
Source Credibility (SC)	SC1	The information source of Pinduoduo group-buying is credible.	(Filieri, Alguezaui, & McLeay, 2015)
	SC2	The information source of Pinduoduo group-buying is reliable.	
	SC3	The information source of Pinduoduo group-buying is trustworthy.	
Similarity (SI)	SI1	The initiator of Pinduoduo group-buying has similar interests with me.	(Johnson & Grayson, 2005)
	SI2	The initiator of Pinduoduo group-buying has similar values with me.	
	SI3	The initiator of Pinduoduo group-buying has similar experience with me.	
Satisfaction (SAT)	SAT1	I feel very satisfied with the overall shopping experience of Pinduoduo.	(Shiau & Luo, 2012)
	SAT2	I feel very pleased with the overall shopping experience of Pinduoduo.	
	SAT3	I feel very contented with the overall shopping experience of Pinduoduo.	
	SAT4	I feel absolutely delighted with the overall shopping experience of Pinduoduo.	
Trust (TR)	TR1	I think the products recommended by the initiator of Pinduoduo group-buying are reliable.	(Huang, 2015)
	TR2	I feel products of Pinduoduo group-buying can meet my needs and preferences.	
	TR3	I feel comfortable clicking the link of products recommended by the initiator of Pinduoduo group-buying.	
	TR4	In general, I have confidence in the initiator of Pinduoduo's product link.	
Urge to Buy Impulsively (UBI)	UBI1	As I click the Pinduoduo group-buying product link, I had the urge to purchase items other than in addition to my specific shopping goal.	(Chen et al., 2019)
	UBI2	As I click the Pinduoduo group-buying product link, I had a desire to purchase items that did not pertain to my specific shopping goal.	
	UBI3	As I click the Pinduoduo group-buying product link, I had the inclination to purchase items outside of my specific shopping goal.	

Data Collection

This study collects data through online questionnaires and selects Pinduoduo group-buying consumers as the research objects. We created and released online questionnaires on the online survey platform "Sojump", and collected data by sharing questionnaire links through various social channels such as WeChat, QQ and Micro-blog. After three weeks, a total of 343 questionnaires were collected. After strict screening: (1) Eliminate incomplete questionnaires; (2) Eliminate questionnaires with the same answers for all measurement items or questionnaires with obvious random answers; (3) Eliminate the questionnaire with wrong answers to trap questions set in the questionnaire, that is, "strongly disagree" is not selected; (4) Eliminate the questionnaire with "no" in the screening questions, that is, respondents are not consumers of Pinduoduo group-buying mode, invalid questionnaires were removed, and 310 valid questionnaires were finally obtained, with an effective recovery rate of 90.38%. The demographic information of the respondents is shown in Table 2.

Table 2. Sample demographics.

Measure	Item	Frequency	Percentage
Gender	Male	116	37.42%
	Female	194	62.58%

Age	<18	6	1.94%
	18-25	230	74.19%
	26-30	46	14.84%
	31-40	15	4.84%
	>40	13	4.19%
Educational level	High school and below	31	10%
	Specialist	38	12.26%
	Undergraduate	182	58.71%
	Master's degree and above	59	19.03%
Personal income in RMB (monthly)	No income yet	121	39.03%
	<3000	54	17.42%
	3000-5000	73	23.55%
	5001-8000	29	9.36%
	8001-10000	24	7.74%
	>10000	9	2.90%

Common Method Bias

Since this research data comes from a single questionnaire collection channel, there may be methodological bias. Therefore, Harman single factor test was used in this study to test the common method deviation of sample data. The test results showed that there was more than one factor with more than one characteristic root extracted from the non-rotating exploratory factor analysis table, and the maximum factor explaining the total variance was less than 40% of the general standard critical value (Tang & Wen, 2020). The results demonstrated that there was no single factor to control the total variance, which manifested that there was no serious common method bias in this research scale, and further data analysis could be carried out.

DATA ANALYSIS AND RESULTS

Measurement Model Evaluation

When evaluating the measurement model, we carried out reliability and validity analysis, and the analysis results are shown in Table 3. According to the previous analysis and evaluation criteria, firstly, the standardized factor loadings of each variable measurement item were all greater than 0.6, indicating that the measurement problem was highly correlated with the corresponding factors. Secondly, according to the reliability analysis, Cronbach's Alpha (CA) of each construct exceeded 0.8, indicating that the scale had good internal consistency and good reliability level. Then according to the standardized factor loadings, the average variance extracted (AVE) and the composite reliability (CR) were calculated, and AVEs were all more than 0.5, signifying that the measurement model had good convergence validity. CRs were all over 0.7, indicating that the scale had good comprehensive reliability. Finally, the correlation analysis was carried out and the square root of AVE was calculated. The analysis results are shown in Table 4. The square root of AVE of all latent variables were greater than the maximum correlation coefficient between this latent variable and other latent variables, indicating that different factors had a good degree of differentiation, showing that the scale had a good discriminant validity. The above analysis outcomes proved that all the constructs showed good reliability and the validity of the structure was verified.

Table 3. Results of reliability and validity analysis.

Constructs	Items	Standardized factors loading	Cronbach's α	CR	AVE
Perceived	PPF1	0.844	0.798	0.804	0.580
Price Fairness (PPF)	PPF2	0.786			
	PPF3	0.641			
Reciprocity (RE)	RE1	0.842	0.875	0.876	0.702
	RE2	0.860			
	RE3	0.810			
Source Credibility (SC)	SC1	0.877	0.906	0.907	0.765
	SC2	0.840			
	SC3	0.905			
Similarity (SI)	SI1	0.801	0.870	0.870	0.690
	SI2	0.864			
	SI3	0.826			
Satisfaction (SAT)	SAT1	0.858	0.899	0.899	0.691
	SAT2	0.813			
	SAT3	0.835			
	SAT4	0.818			
Trust (TR)	TR1	0.738	0.858	0.860	0.605
	TR2	0.758			

	TR3	0.785			
	TR4	0.828			
Urge to Buy	UBI1	0.784	0.860	0.861	0.675
Impulsively	UBI2	0.789			
(UBI)	UBI3	0.887			

Table 4. Analysis of discriminant validity.

Constructs	PPF	RE	SC	SI	SAT	TR	UBI
Perceived Price Fairness (PPF)	0.762						
Reciprocity(RE)	0.412	0.838					
Source Credibility(SC)	0.389	0.378	0.874				
Similarity(SI)	0.297	0.370	0.445	0.831			
Satisfaction(SAT)	0.424	0.504	0.520	0.512	0.831		
Trust(TR)	0.364	0.451	0.526	0.446	0.711	0.778	
Urge to Buy Impulsively(UBI)	0.139	0.200	0.335	0.398	0.373	0.415	0.821

Structural Model Evaluation

AMOS 24.0 was used in this study to evaluate the structural model. The fitting degree of the structural model is presented in Table 5. Absolute fitness index: The value of CMIN / DF was 2.154 between the reference value 1 to 3 (Zhang & Wei, 2019), which was in line with the standard; the value of RMSEA was 0.061, greater than 0.05, less than 0.08 (Zhang & Wei, 2019), within the acceptable range; according to the evaluation standard of Huang (2015), the value of GFI and AGFI were 0.885 and 0.853 respectively, both exceeded 0.8, illustrating that the goodness of model fitting was acceptable. The value-added fitness index: the value of NFI, IFI and CFI were 0.901, 0.945 and 0.944, respectively, which were all greater than 0.9, revealing that the model had a good fitness (Zhang, Yang, & Zhang, 2020). these outcomes showed that the overall model had good fitting degree and good modelability.

Table 5. Overall fits of the model.

Fit index	Recommended criteria	This research	Evaluation
CMIN/DF	1~3	2.154	Ideal
GFI	>0.8	0.885	Acceptable
AGFI	>0.8	0.853	Acceptable
NFI	>0.9	0.901	Ideal
IFI	>0.9	0.945	Ideal
CFI	>0.9	0.944	Ideal
RMSEA	<0.05~0.08	0.061	Acceptable

Model Verification

The model verification results are shown in Figure 2, including the coefficients and their significance. With the exception of hypothesis 6 (represented by dashed line), all other assumptions are supported.

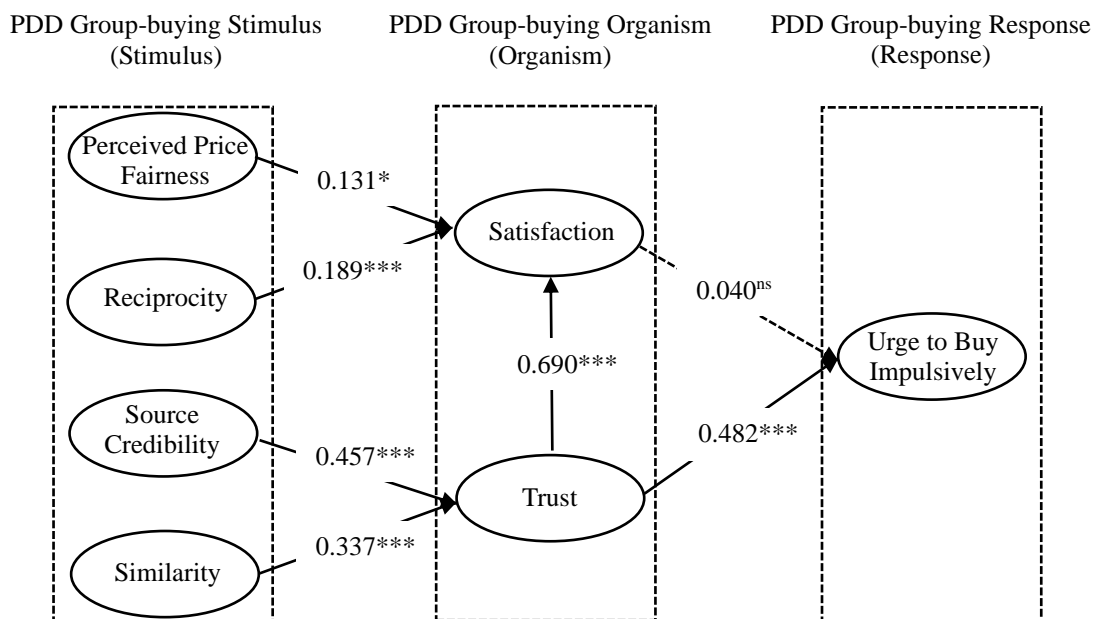

Note: *** $p < 0.001$; ** $p < 0.01$; * $p < 0.05$. ns: non-significant at the 0.05 level.

Figure 2. Research model testing results.

Mediation Analysis

For further probe the impact mechanism of Pinduoduo group-buying mode on impulse buying, this study further tested the significance of the indirect influence involved in the model. The bootstrap method proposed by Preacher and Hayes (2008) was used to test the mediating effect, and the sample size of 5000 were set under the 95% confidence interval, meanwhile, the test was conducted with reference to the intermediary effect test procedure summarized by Zhao *et al.* (2010), the analysis results are presented in Table 6. For the path analysis with satisfaction as the intermediary: satisfaction had a complete mediating effect between perceived price fairness and urge to buy impulsively (the confidence interval of indirect effect was [0.0543,0.2207], excluding 0; the confidence interval of direct effect was [-0.1872,0.1142], including 0); satisfaction had a complete mediating effect in the process of reciprocity stimulating urge to buy impulsively (the confidence interval of indirect effect was [0.0943,0.2675], excluding 0; the confidence interval of direct effect was [-0.1189,0.1756], including 0); the mediating effect of satisfaction on trust and urge to buy impulsively was not significant (the confidence interval of indirect effect was [-0.0524,0.2692], including 0). For the trusting-mediated path analysis: trust completely mediated the impact of source credibility on urge to buy impulsively (the confidence interval of indirect effect was [0.0441,0.2078], excluding 0; the confidence interval of direct effect was [-0.0326,0.2285], including 0); trust has a partial mediating role in the impact of similarity on urge to buy impulsively (the confidence interval of indirect effect was [0.0240,0.1408], excluding 0; the confidence interval of direct effect was [0.1373, 0.3825], excluding 0).

Table 6. Bootstrap mediation test results.

Mediation path	Point estimation	Indirect effect	Direct effect	Result
PPF→SAT→UBI	0.0429	[0.0543,0.2207]	[-0.1872,0.1142]	Complete mediation
RE→SAT→UBI	0.0445	[0.0943,0.2675]	[-0.1189,0.1756]	Complete mediation
SC→TR→UBI	0.0419	[0.0441,0.2078]	[-0.0326,0.2285]	Complete mediation
SI→TR→UBI	0.0303	[0.0240,0.1408]	[0.1373,0.3825]	Partial mediation
TR→SAT→UBI	0.0816	[-0.0524,0.2692]	[0.1800,0.5075]	No mediation

DISCUSSION AND IMPLICATION

Discussion of Results

In this study, a latent variable structural equation model was established to verify the influence path of Pinduoduo group-buying mode on impulse buying. Empirical results showed that all hypotheses were supported by verification except hypothesis 6.

Firstly, the results of this study show that perceived price fairness and reciprocity in group-buying mode both have a significant positive impact on consumer satisfaction ($\beta_{PPF \rightarrow SAT} = 0.131$, $P_{PPF \rightarrow SAT} < 0.05$; $\beta_{RE \rightarrow SAT} = 0.189$, $P_{RE \rightarrow SAT} < 0.001$). Among them, reciprocity has a greater impact on satisfaction than perceived price fairness. This is because compared with the personal benefits brought by low prices, people are more inclined to seek the common interests of the group. Only when all parties benefit can they achieve sustainable development, which is also the trend of social development.

Secondly, in the group-buying mode, the credibility of the information source generated by using WeChat social circle as the communication channel and the similarity between group participants have a significant positive impact on consumer trust ($\beta_{SC \rightarrow TR} = 0.457$, $P_{SC \rightarrow TR} < 0.001$; $\beta_{SI \rightarrow TR} = 0.337$, $P_{SI \rightarrow TR} < 0.001$). Among them, source credibility is more likely to generate trust among consumers, because the information source is the key determinant of trust, and consumers generally trust the information conveyed by relatives and friends more (Xie, Sheng, & Gong, 2019).

Thirdly, consumer trust positively affects consumer satisfaction ($\beta = 0.690$, $P < 0.001$). Trust in the originator of the Pinduoduo group-buying link can have a significant impact on consumers' attitude. Recipients who trust the group purchase link will emotionally evaluate the information of the initiator of the group purchase, and have a positive emotional response to the product, and then feel satisfied with the product.

Fourthly, consumer trust has a positive impact on urge to buy impulsively ($\beta = 0.482$, $P < 0.001$), but consumer satisfaction has no significant effect on urge to buy impulsively, assuming 6 does not hold. This is because although the products under the Pinduoduo group-buying mode are economical and satisfying, consumer satisfaction is not all the determinants of impulse buying. Consumers will have negative emotions such as perceived risk psychology due to the uncertainty of product quality. When the perception of negative emotions is more than positive emotions, it will hinder consumers' impulse purchase, so this may be the reason for the insignificant results. Future research can further consider the influence of product quality as a stimulus on impulse buying.

Implications

Implications for Theoretical Research

This paper uses S-O-R framework to discuss the influence mechanism of Pinduoduo group-buying model on impulse buying. In the light of the results of empirical analysis, it can be seen that the social-based group-buying mode helps to promote consumer impulse purchase to a large extent. Different from previous studies on impulse buying from a single perspective, this article combines shopping contextual factors (perceived price fairness, reciprocity, source credibility and similarity) and

consumer psychological factors (satisfaction and trust) to reveal the mechanism of Pinduoduo group-buying mode on impulse purchase, and more effectively explains the development process of consumers' impulse buying under the group-buying mode. Taking Pinduoduo platform as the research object, this study comprehensively discusses the influence of its group-buying mode on the formation of consumers' impulsiveness to purchase, which makes up for the lack of research on consumers' irrational behaviors under the mode of social e-commerce group-buying in existing literature. This paper takes the emerging social business as the research context to further enrich the theoretical research of impulse buying.

Implications for Practical Research

The findings of this paper provide some valuable insights for social business enterprises, especially for Pinduoduo operators. In terms of satisfaction and trust, the outcomes of this research display that trust has a significant positive impact on urge to buy impulsively. Therefore, social commerce platforms such as Pinduoduo should pay attention to taking measures to enhance consumers' trust. For example, Pinduoduo operators can enhance the credibility by improving the credibility of group-buying information sources and the similarity of group-buying initiators, that is, the platform should effectively supervise the security of the group purchase link, prevent the intrusion of false virus information, and filter the information shared by the circle of friends; at the same time, Pinduoduo should reasonably distinguish consumer needs and preferences based on historical shopping records, recommend and classify friends lists with similar consumption preferences and needs, and guide customers to share in a targeted way to avoid causing harassment to other users. Pinduoduo should continue and strengthen cooperation with WeChat platform, launch Pinduoduo group purchase link with WeChat circle of friends, so as to achieve promotion, but the degree and quality should be strictly controlled to achieve the goal of moderate promotion and high quality content.

With the increasing number of social business platforms and the rapid development of marketing means, how to improve the competitiveness of Pinduoduo group-buying mode to stimulate consumers to buy on impulse has become an important issue. Marketing innovation is on the one hand, but more depends on the product itself. At present, the biggest problem of Pinduoduo is product quality caused by low prices. Pinduoduo has attracted a large amount of traffic due to its low price and great benefits. However, due to the poor post purchase experience, Pinduoduo has been complained by many buyers, which seriously damaged Pinduoduo's reputation. Therefore, Pinduoduo should strictly control the product quality, and quickly remedy it through measures such as raising the threshold for merchants to enter the platform, monitoring product production processes, and improving after-sales service, so as to improve the consumer experience and promote the impulse purchase of consumers. Pinduoduo should continue to maintain the advantage of low price, identify price-sensitive customer groups, and make personalized recommendations based on demand preferences.

Limitations and Future Research

The limitations and future research directions of this article are as follows. The first is limited to external validity. Our research background is limited to Pinduoduo platform. Therefore, future research can be extended to other social commerce platforms to test our research results. Secondly, our research results cannot be extended to other countries. In future studies, our model can be tested in different cultures, and the differences of test results under different cultures can also be compared for further research. Then, this study only uses the form of online questionnaire to conduct the survey, and there will be some deviation. Future studies can adopt diversified methods or multiple sources to collect data to verify our findings. Finally, this study only focuses on the four situational factors of stimulation, and many other factors are still worth exploring (for example, time pressure, scarcity, etc.), which can be considered in future studies.

REFERENCES

- [1] Bressolles, G., Durrieu, F., & Giraud, M. (2007). The impact of electronic service quality's dimensions on customer satisfaction and buying impulse. *Journal of Customer Behaviour*, 6(1), 37-56. doi: 10.1362/147539207X198365
- [2] Chen, Y., Lu, Y., Wang, B., & Pan, Z. (2019). How do product recommendations affect impulse buying? An empirical study on WeChat social commerce. *Information & Management*, 56(2), 236-248. doi: 10.1016/j.im.2018.09.002
- [3] Choi, B., & Lee, I. (2017). Trust in open versus closed social media: The relative influence of user-and marketer-generated content in social network services on customer trust. *Telematics and Informatics*, 34(5), 550-559. doi: 10.1016/j.tele.2016.11.005
- [4] Chou, H. Y. (2019). Units of time do matter: How countdown time units affect consumers' intentions to participate in group-buying offers. *Electronic Commerce Research and Applications*, 35, 100839. doi: 10.1016/j.elerap.2019.100839
- [5] Filieri, R., Alguezaui, S., & McLeay, F. (2015). Why do travelers trust TripAdvisor? Antecedents of trust towards consumer-generated media and its influence on recommendation adoption and word of mouth. *Tourism Management*, 51, 174-185. doi: 10.1016/j.tourman.2015.05.007
- [6] Gong Yanping & Liang Shulin. (2015). A study on the influence of group buying service scenarios on consumers' purchase intention. *East China Economic Management*, 29(11), 1-9. doi: 10.3969/j.issn.1007-5097.2015.11.001
- [7] Han Li. (2012). Economic thinking on the development of online group buying in China. *Commercial Time*, (7), 41-42. doi: 10.3969/j.issn.1002-5863.2012.07.019
- [8] Hsu, C. L., & Lin, J. C. C. (2008). Acceptance of blog usage: The roles of technology acceptance, social influence and knowledge sharing motivation. *Information & Management*, 45(1), 65-74. doi: 10.1016/j.im.2007.11.001
- [9] Huang, L. S. (2015). Trust in product review blogs: The influence of self-disclosure and popularity. *Behaviour & Information Technology*, 34(1), 33-44. doi: 10.1080/0144929X.2014.978378

- [10] Johnson, D., & Grayson, K. (2005). Cognitive and affective trust in service relationships. *Journal of Business Research*, 58(4), 500-507. doi: 10.1016/S0148-2963(03)00140-1
- [11] Konuk, F. A. (2019). The influence of perceived food quality, price fairness, perceived value and satisfaction on customers' revisit and word-of-mouth intentions towards organic food restaurants. *Journal of Retailing and Consumer Services*, 50, 103-110. doi: 10.1016/j.jretconser.2019.05.005
- [12] Liu, Y., Li, H., & Hu, F. (2013). Website attributes in urging online impulse purchase: An empirical investigation on consumer perceptions. *Decision Support Systems*, 55(3), 829-837. doi: 10.1016/j.dss.2013.04.001
- [13] Lu, B., Fan, W., & Zhou, M. (2016). Social presence, trust, and social commerce purchase intention: An empirical research. *Computers in Human Behavior*, 56, 225-237. doi: 10.1016/j.chb.2015.11.057
- [14] Namasivayam, K., & Guchait, P. (2013). The role of contingent self-esteem and trust in consumer satisfaction: Examining perceived control and fairness as predictors. *International Journal of Hospitality Management*, 33, 184-195. doi: 10.1016/j.ijhm.2012.08.002
- [15] Preacher, K. J., & Hayes, A. F. (2008). Asymptotic and resampling strategies for assessing and comparing indirect effects in multiple mediator models. *Behavior Research Methods*, 40(3), 879-891. doi: 10.3758/BRM.40.3.879
- [16] Sharma, V. M., & Klein, A. (2020). Consumer perceived value, involvement, trust, susceptibility to interpersonal influence, and intention to participate in online group buying. *Journal of Retailing and Consumer Services*, 52, 101946. doi: 10.1016/j.jretconser.2019.101946
- [17] Shiau, W. L., & Luo, M. M. (2012). Factors affecting online group buying intention and satisfaction: A social exchange theory perspective. *Computers in Human Behavior*, 28(6), 2431-2444. doi: 10.1016/j.chb.2012.07.030
- [18] Stern, H. (1962). The significance of impulse buying today. *Journal of Marketing*, 26(2), 59-62. doi: 10.1177/002224296202600212
- [19] Tai, C. L., Hong, J. Y., Chang, C. M., & Chen, L. C. (2012). Determinants of consumer's intention to participate in group buying. *Procedia-social and Behavioral Sciences*, 57, 396-403. doi: 10.1016/j.sbspro.2012.09.1203
- [20] Tang Dandan, & Wen Zhonglin. (2020). Common method bias testing: Problems and suggestions. *Psychological Science*, (1), 215-223. doi: 10.16719/j.cnki.1671-6981.20200130
- [21] Wang Qiuzhen, Yao Qian, & Ye Ying. (2014). Research on the influence mechanism of price discount and number of buyers on consumers' impulse purchase intention under online group buying scenario. *Journal of Industrial Engineering and Engineering Management*, (4), 37-47. doi: 10.3969/j.issn.1004-6062.2014.04.005
- [22] Wang, X.H. & Chen, J.F. (2020). Research on new professional farmers' acceptance of information service and influencing factors based on Structural Equation Model. *Science and Technology Management Research* (19), 167-174. doi: 10.3969/j.issn.1000-7695.2020.19.024
- [23] Xiao, L. (2018). Analyzing consumer online group buying motivations: An interpretive structural modeling approach. *Telematics and Informatics*, 35(4), 629-642. doi: 10.1016/j.tele.2018.01.010
- [24] Xie, F., Sheng, G.H., & Gong, S.Y. (2019). Study on the influence of reference groups on green consumption behavior of Chinese residents under the background of civil environmental co-governance. *China Population, Resources and Environment*, (8), 8. doi: 10.12062/cpre.20190321
- [25] Zafar, A. U., Qiu, J., Li, Y., Wang, J., & Shahzad, M. (2019). The impact of social media celebrities' posts and contextual interactions on impulse buying in social commerce. *Computers in Human Behavior*, 115, 106178. doi: 10.1016/j.chb.2019.106178
- [26] Zhang Hong, Lu Yaobin, & Yan Yanling. (2017). Research on the influence of technical characteristics of social shopping community on purchase intention. *Science Research Management*, 38(2), 84-92. doi: 10.19571/j.cnki.1000-2995.2017.02.011
- [27] Zhang, H., Wang, Z., Chen, S., & Guo, C. (2019). Product recommendation in online social networking communities: An empirical study of antecedents and a mediator. *Information & Management*, 56(2), 185-195. doi: 10.1016/j.im.2018.05.001
- [28] Zhang Peng, Xie Maodi, Zhao Dongyuan, & Mei Lei. (2019). The influencing factors of online community on consumers' impulsive buying: Model and empirical analysis. *Business Economics Research*, (4), 20. doi: 10.3969/j.issn.1002-5863.2019.04.019
- [29] Zhang, S., & Wei, M. (2019). The formation of online impulse buying desire: An empirical study based on social commerce. *Journal of Jinan University (Philosophy and Social Sciences)* (05), 17-29. doi: 10.3969/j.issn.1000-5072.2019.05.002
- [30] Zhang, W., Yang T., & Zhang W.K. (2020). Research on the influence mechanism of mobile shopping situation factors on impulse purchase intention. *Management Review*, 32 (2), 174-183. doi: 10.14120/j.cnki.cn11-5057/f.2020.02.014
- [31] Zhang, Y. & Xu, B. (2019). Research on the strategy of e-commerce platform guided group buying based on social group buying. *Management Review*, 31 (10), 133-141. doi: 10.14120/j.cnki.cn11-5057/f.2019.10.012
- [32] Zhao, X., Lynch Jr, J. G., & Chen, Q. (2010). Reconsidering Baron and Kenny: Myths and truths about mediation analysis. *Journal of Consumer Research*, 37(2), 197-206. doi: 10.1086/651257
- [33] Zheng, D. & Zhang, Z. (2018). Value creation and transmission: An analysis of the business model of online group buying in China. *Modernization of Management*, 38 (1), 71-75. doi: 10.19634/j.cnki.11-1403/c.2018.01.021
- [34] Zheng, X., Men, J., Yang, F., & Gong, X. (2019). Understanding impulse buying in mobile commerce: An investigation into hedonic and utilitarian browsing. *International Journal of Information Management*, 48, 151-160. doi: 10.1016/j.ijinfomgt.2019.02.010

The Role of ICT in Sustainable Development: The Ugandan Narrative

(Full Paper)

Samuel Ekundayo*, Centre for Inclusive Digital Enterprise and Eastern Institute of Technology, Auckland, New Zealand. sekundayo@eit.ac.nz

Maryam Tabatabaee, Centre for Inclusive Digital Enterprise, Iran. tabatabaee.1212@gmail.com

Karthik Sridhar, Centre for Inclusive Digital Enterprise, University of Canterbury, New Zealand. ksr38@uclive.ac.nz

ABSTRACT

This article investigates the effectiveness of information and communications technologies in sustainable development among non-OECD economies that encapsulate its underlying beliefs and values. Specifically, we have developed a data-driven narrative by using Uganda as the subject of case analysis. We performed statistical analysis to study the significance of ICT as an enabler to the overall socio-economic development. There is a missing component comprising digital literacy and participation that have calls into question the mediating role of inclusive growth. Both our method and findings adopt generally accepted protocols for case studies. The contribution of this research is interpretivist in nature, and we recommend that similar studies need to be replicated by researchers across geographies and domains.

Keywords: Information technologies for development, digital divide and sustainable development goals.

*Corresponding author

THE SOCIO-ECONOMIC CONTEXT OVERVIEW

Uganda is a former British colony in the African subcontinent that became independent on 6th October 1962. Uganda is one of the least developed countries in the world and is ranked as one of the lowest in the African region (Ndiwalana *et al.*, 2012). However, like many other developing countries, Uganda has experienced consistent economic growth over the years. This article investigates the main reason for this economic growth and determines whether this is due to their expanding commercial exports through the lens of a data-driven narrative (Sharma & Ravindran, 2020). Given that most developmental perspectives are mostly through the lens of neo-classical World Bank, IMF (International Monetary Fund) or OECD (Organisation for Economic Co-operation and Development) analyses, such a narrative is overdue and attempts to make a contribution to the gap in this body of knowledge.

An improvement in the economy does not necessitate a reduction in poverty. As illustrated in figure 1, Uganda, when benchmarked with its neighbours, is on a growth trajectory. However, the poverty levels in Uganda keeps increasing even though their Gross Domestic Product (GDP) was increasing pre-COVID. Since COVID however, Uganda’s real GDP this year is projected to be between 0.4 and 1.7% compared to 5.6% in 2019. From this alone, we can suspect that corruption will play a large role in answering the main question of this report. Uganda finds itself with a very low Human Development (HDI) value of 0.528, which is 159th in the world (UNDP, 2020).

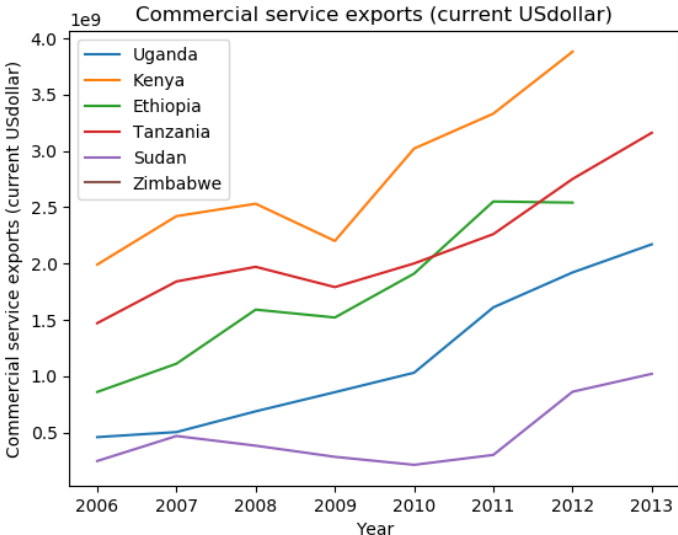

Figure 1: Commercial service exports of Uganda and similar countries.

The level of corruption in Uganda has seen a major increase in the last decade (Buntaine & Daniels, 2020). Uganda is the 137th least corrupt country in the world out of 180 countries (Trading Economics, 2019). Less than half of Uganda's population own a mobile phone, whereas this market is close to mobile phone saturation in countries such as South Africa (83%) and Kenya (87%). The current draft of the Vision is constrained however by the fact that Uganda has one of the lowest (14%) Internet penetration rates of the 10 African countries surveyed by Research ICT Africa (RIA) as part of the Global South After Access Survey conducted between 2017 and 2018. And amongst the participant countries Uganda has the second-poorest Networked Readiness Index (NRI) score, ahead of only Cameroon (Gillwald, 2019).

According to the World Economic Forum (WEF), Uganda's political and regulatory environment is very robust, but its market and infrastructural environments are poor (WEF, 2011). In terms of both readiness and use, the WEF sees the Ugandan government as doing satisfactorily; but businesses are slightly behind, while individuals are seen as still lagging, reflecting potential room for growth in terms of demand for ICT services.

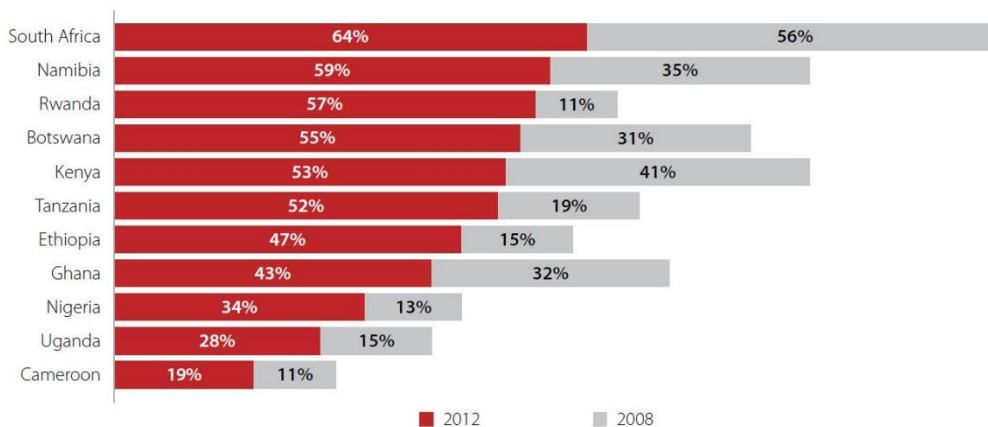

Figure 2: Daily Internet Use among web users in RIA Countries.

When considering the digital infrastructure, a key factor of competitiveness in the digital era, daily internet use has grown across Africa, as shown in Figure 2, and this increase may be attributed to better connectivity as a result of the landing of more undersea cables at the East African coast. However, the resulting retail price drops have not been as significant as expected. Internet use is also increasingly mobile because more users now have internet-capable handsets and other mobile devices, allowing internet connectivity. There is another body of theories that claims knowledge management (KM) provides the solution for leveraging ICT (cf. Sharma *et al.* 2008; 2009; 2012; 2016). This is evident because many sectors are influenced by KM for sustainable development. The analysis in this article uses data from the Uganda Sector Performance Review (SPR) based on the 2012 Research ICT Africa (RIA) Household and Individual ICT Access and Use Survey for Uganda, which delivered nationally representative results for households and individuals by using enumeration areas prepared by the Uganda Bureau of Statistics (UBOS) combined with suitable sample design.

Uganda's ICT sector has continued to grow over the last few years, driven by demand for both mobile voice and mobile internet services, with the ICT sector contributing 6% of the national GDP in 2010 (Ssewanyana *et al.*, 2007).

The most significant recent development in Uganda's ICT sector was the announcement in 2010 of the merger of the two regulators, the Uganda Communications Commission (UCC) and the Broadcasting Council (BC), to form one regulatory body, still known as the Uganda Communications Commission (UCC) (Ministry of Information and Communications Technology, 2010). The Ministry is supported by regulatory agencies that include the UCC – regulating the telecommunications sector and responsible for management and implementation related to the Rural Communications Development Fund; and the National Information Technology Authority Uganda (NITA-U) – regulating the IT sector and also responsible for roll-out and operation of the National Backbone and e-Government Infrastructure (Gillwald *et al.*, 2019). In the digital era, content and media as an innovation asset has been well-researched (cf Sharma & Wildman, 2009).

Fierce competition in mobile voice services has driven tariffs down to the point of eliminating price differentials between on-net and off-net calls. Despite this, Uganda is still poorly ranked in Africa in terms of mobile voice cost, and its interconnection rate is still higher than in neighbouring Kenya and Tanzania (Waema *et al.*, 2014). During the 2010-11 period, the number of Ugandan mobile subscribers increased by a record of 4.37million to a total of 16.7million. The RIA African Mobile Pricing (RAMP) Index shows that in Uganda in 2018 it would cost UGX 10 000—far above the means of a country with a GNI per capita of only USD 1 820, a per capita income level which the majority of the population live below. The 2018 RIA After Access Survey confirms that affordability of devices and services is the main constraint on uptake and use.

Access to the internet has improved, with Uganda having an estimated 4.8million internet users as of December 2011 – partially due to lowering of prices since the landing of new fibre optic undersea cables on the east coast of Africa. Retail internet charges have not, however, dropped as much as would have been expected given the new fibre access because there is no effective backhaul competition. Human capital is one of the essential for innovation and development (Sharma *et al.*, 2008; 2009). Individual internet access takes place predominantly via mobile telephony platforms, and access to computers remains very limited at only 4.8%. However, the perceived level of effectiveness of Uganda’s regulatory environment, historically evaluated as one of the best on the continent, has steadily declined.

This section provides an overview of ICT for sustainable development. The next section is a descriptive account of Uganda’s experiences with ICT-enabled development. Section 3 introduces a 4-pillar research framework adapted from Sharma *et al.* (2016) that serves as a lens for data analytics. Section 4 distils findings in the form of a narrative (cf. Sharma & Ravindran, 2020) that specifically discusses interesting caveats and policy imperatives. The article concludes with some thoughts for further research.

ICT AND UGANDA’S GROWTH TRAJECTORY

The ICT services sector dominates Uganda’s GDP (contributing 45.1% in 2011-12), in comparison to industrial manufacturing (26.3%) and agriculture, forestry, and fishing (23.7%), as summarized in Table 1.

Table 1: GDP contribution by sub-sector

	2007-8	2008-9	2009-10	2010-11	2011-12
Agriculture, forestry, and fishing	21.4%	23.1%	23.6%	22.7%	23.7%
Industry	25.8%	24.7%	24.9%	25.3%	26.3%
Services	46.9%	46.4%	45.5%	46.2%	45.1%

Except during the financial year (2011-12), growth in services has outpaced growth in the industry sub-sector and agriculture, forestry, and fishing sub-sector in terms of GDP contributions, as shown in Table 1. One of the major components of the services sector is posts and telecommunications, which contributed 6% of GDP in the 2010 calendar year - primarily through foreign direct investment (FDI), employment, and paying taxes (Desai *et al.*, 2000). While competition has helped drive down ICT service costs, the costs are still high for Ugandans in low-income brackets. Typical costs, such as purchasing airtime or credit to call, include Pay-As You Earn (PAYE) 16.5%, Value Added Taxes (VAT) 27.9% and excise duty 9.4%, increasing the total cost by about 30%. While such taxes generate income for the government (see Figure 3), they also potentially stifle the growth and reach of telecommunications services.

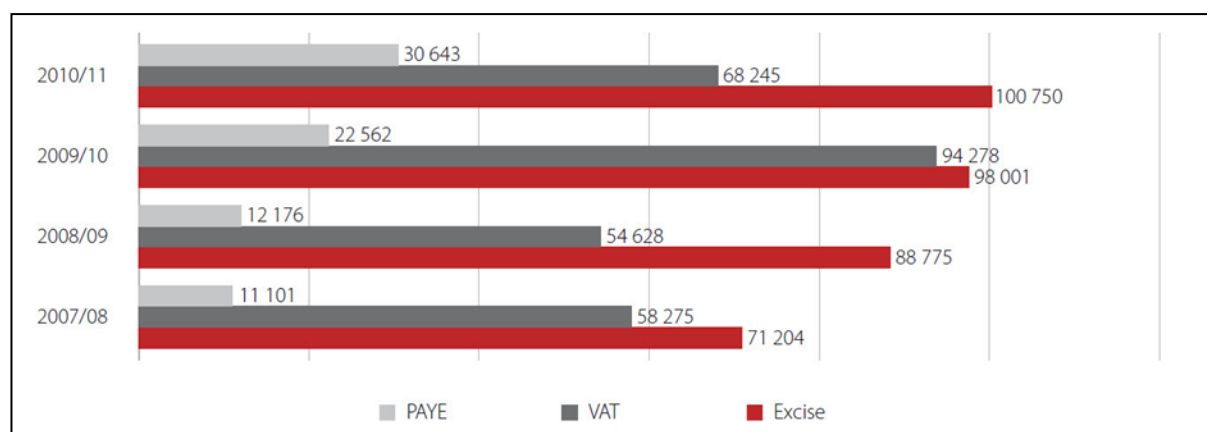

Figure 3: Telecommunications sector contributions to national tax revenues (UGX, millions).

Evidence of the role played by pricing in ICT use can be inferred from the fact that the price war amongst operators in 2009, which reduced the price of mobile voice services, resulted in the largest one-year growth in new mobile subscriptions to date, with 4.37million new subscribers added during 2010-11 (Kasigwa *et al.*, 2006). This subscriber growth also accounts for the surge in the telecommunications sector’s contribution to GDP – a contribution that doubled from 3.1% to 6.2% between 2009 and 2010.

Table 2: Growth rates of GDP sub-sectors

	2007-8	2008-9	2009-10	2010-11	2011-12
Total GDP growth	8.7%	7.3%	5.9%	6.7%	3.2%
Agriculture, forestry, and fishing	1.3%	2.9%	2.4%	0.7%	3%
Industry	8.8%	5.8%	6.5%	7.9%	1.1%
Services	9.7%	8.8%	8.2%	8.4%	3.1%

Over the past decade, telecommunications operators have made significant investments in the Ugandan economy, and have, in turn, reaped substantial revenues (as summarised in Figure 3).

However, in 2010-11, sector revenue dropped to US\$660 million from US\$669 million in 2009-10, partly due to the Ugandan shilling’s weakening against the US dollar (Avgerou, 2010). Mobile network operators derive their revenues from a range of services that include, according to the UCC (proportions in brackets and based on 2009 figures):

- Mobile operations (voice, SMS, mobile money, handsets, etc.) (63%);
- Domestic interconnection (16%);
- Fixed-line revenue (14%);
- Internet revenue (4%);
- International termination, roaming, etc. (2%); and
- Other (1%) (UCC, 2012).

ICTs provide an opportunity for nations to address the digital divide and reduce poverty while registering economic growth. Developed and some developing nations have seen the emergence of a vibrant ICT sector that significantly contributes to national GDP (Ssewanyana, 2007). It is this ICT sector that should be built, in most cases, through public-private partnerships. ICTs are enablers for economic growth because of their cross-cutting nature, thus affecting all sectors. Knowledge disparities cannot contribute to the growth of ICT. For this growth to occur, there has to be inclusion of knowledge and innovation to provide sustainable development (Sharma, 2018). Adoption and proper utilization of ICTs will lead, among others, to increased yields and quality production of goods and services. ICT industry can be resourced, properly managed, and mainstreamed into a significant contributor to GDP.

ANALYTIC METHODS

We performed statistical analysis to study the significance of ICT as an enabler to the overall socio-economic development of Uganda by adopting the research framework proposed by Sharma and his co-workers (Sharma *et al.*, 2016) after reviewing three other theories by International Telecommunication Union (2017), Palvia *et al.* (2018), and Bowles (3013). Deploying a “grounded theory” approach that examined 5 OECD economies in order to understand the nexus between ICT and growth, Sharma *et al.* (2016) prescribed a 4-pillar theory as illustrated in figure 4. They theorised that the Innovation, Human Capital, Governance, and Infrastructure capabilities of an economy will contribute to digital inclusion and participation of people and processes; and with digital literacy as absorptive capacity, sustainable development will be the outcome.

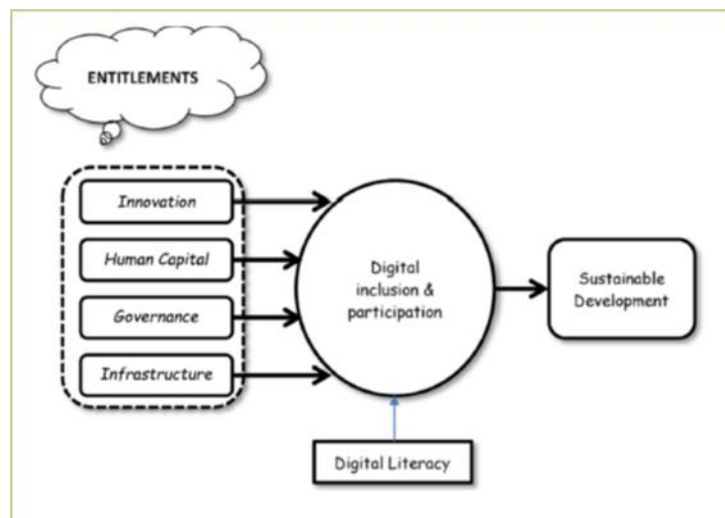

Figure 4: ICT for Development framework (source: Sharma *et al.* 2016, 641).

Data Sources

In our analysis, we use data from several sources. Firstly, for the indicators, we have used the World Development Indicators (WDI), which is a dataset compiled by the World Bank from officially-recognized international sources (World Development Indicators, 2016). We believe that this dataset can be trusted for the purpose of this report. Another set of indicators that we use come from the World Governance Indicators (WGI) dataset, which has also been compiled by the World Bank.

Predictors (ICT Indicators)

For the purpose of our analysis, we selected, on average, ten independent variables for manageability from each of the four pillars that constitute the ICT-4D model: Innovation, Human Capital; Governance; Infrastructure.

Through analysing our model, we hope to understand the correlation between our indicators and the outcome variables. More technically, we will create a multi-linear regression model using a Generalised Least Squares (GLS) method. Using each year (2006 to 2014) as observations, we face challenges in our modelling.

Firstly, we have a limited number of observations to use in our model. Using ten indicators from each of the four pillars of ICT development, we have 40 predictors trying to model eight observations (Sharma *et al.*, 2016). Hence, we face the classic statistical problem of dimensionality reduction. There are several strategies for this, such as PCA, ICA, but we chose to stick with a simple variable selection technique. To select the best indicators, we calculate the F-score of the indicator with respect to SSI. From this, we can calculate the p-value from which we can sort the indicators. We select the top four indicators to use in our multiple linear regression model. Four indicators have sufficient variance. Using this method, the selected variables were:

- Fixed telephone subscriptions
- Fixed telephone subscriptions (% of the population)
- Unemployment level of men (% of the male labour force)
- The time required to enforce a contract (days)

We violated an assumption of linear models that observations must be independent of each other. However, we found that we can still extract valuable information.

Outcome (Dependent variable)

The Sustainable Society Index, SSI, shows at a glance the level of sustainability of each of the 151 assessed countries, included in the SSI. It shows in a simple way the distance to full sustainability for each of the 24 indicators that build up the SSI. The SSI is used for monitoring the progress of a country on its way to sustainability, for setting priorities with respect to sustainability, to make comparisons between countries, for education purposes, and for further research and development.

The SSI has three dimensions, namely: Human Wellbeing, Environmental Wellbeing, and Economic Wellbeing. Human Well-being and Environment Wellbeing are the goals of a country, while Economic Wellbeing is needed to achieve maximum sustainability. Here we are comparing the three SSI dimensions. There is longstanding tradition in IS research of combining Critical Success Factors (CSF) and Delphi that measures to derive indication of success of socio-technical systems (Conrath & Sharma, 1992). We adopted a similar approach in this research.

Besides Human Wellbeing, the other two indicators are stable over the last eight years. Specifically, Human Wellbeing has had some variations worthy of further investigation. Compared to Uganda, the Human Well-being index for every other African country have shown a constant rise.

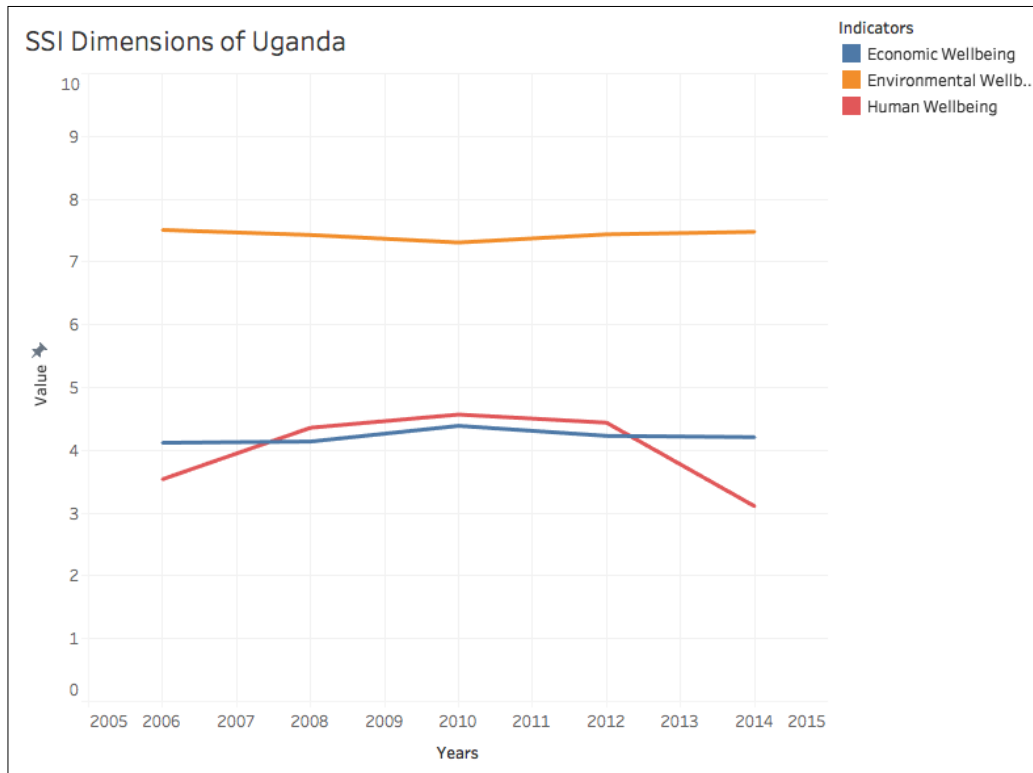

Figure 5: Uganda's Sustainable Society Index.

Clearly, Uganda has experienced a downfall in human well-being from 2012. We attribute it to the combination of the civil unrest which occurred in 2012 and continuing political uncertainties. In our analysis, we found out another interesting fact that the import of arms has seen a sudden rise in 2011-2012. This shows that the government has been spending more on the military, which could have gone into investing in social capital.

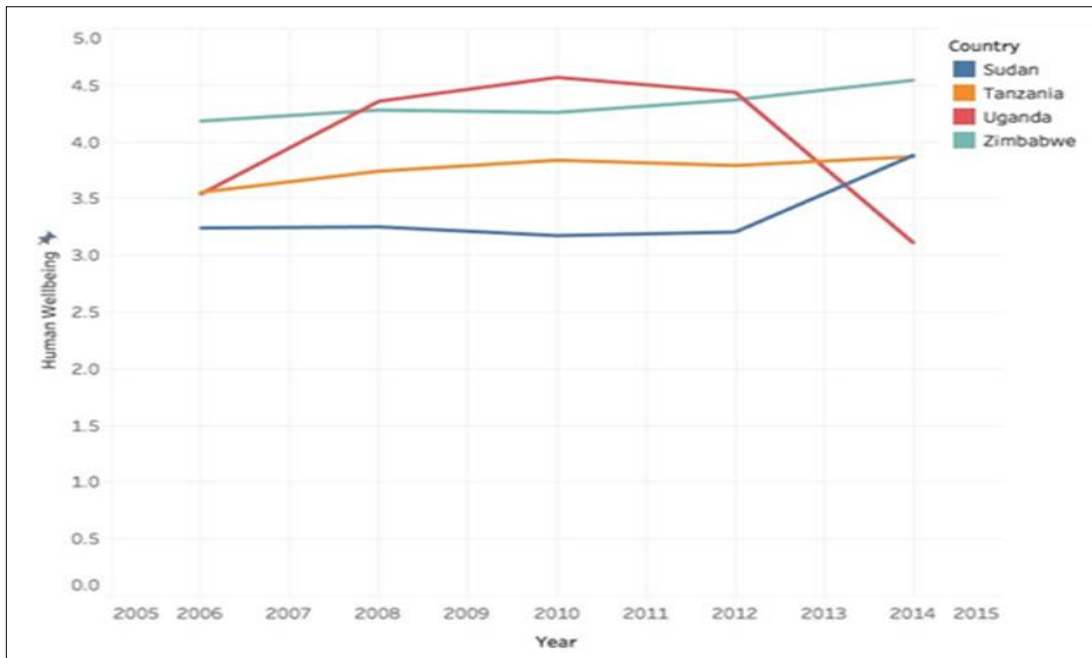

Figure 6: Human Wellbeing across African Countries.

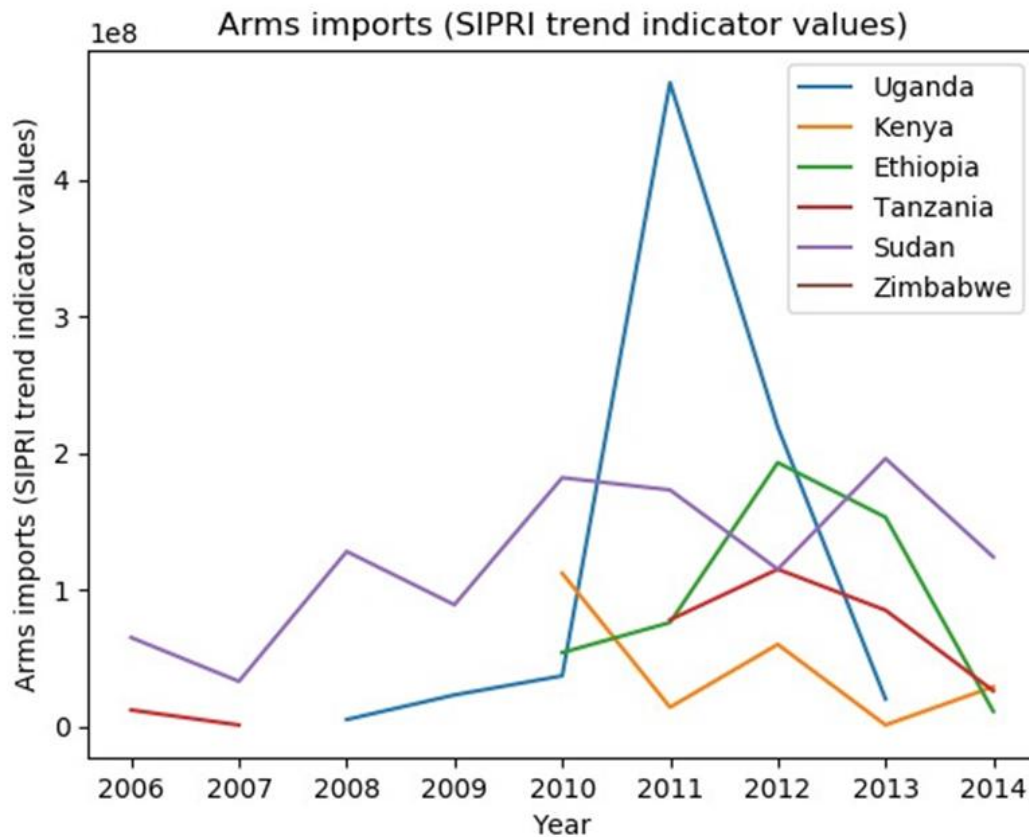

Figure 7: Arms Import Trends across African Countries.

RESULTS AND DISCUSSION

Initially, we had modelled using the aggregate SSI as the output but found that the model was difficult to interpret. After modifying the model to use the Human Wellbeing index (of SSI), we were able to obtain a reasonable result. The first thing to note is that we have a high adjusted R2 value of 0.876, meaning that we can explain 87.6% of the model error. This is reasonably expected, given our small dataset. Of the four selected indicators, we can safely ignore the coefficients for two, namely, 'Unemployment level of men' and 'fixed telephone subscriptions.' The former has a p-value of 0.93, which is far beyond the regular threshold of 0.05, the latter is too similar to 'Fixed telephone subscriptions (% of the population)' whilst not providing any additional information.

Our model suggests that 'Fixed telephone subscriptions (% of the population)' plays a role in determining the Human Wellbeing of Uganda. The coefficient of 1.54 suggests that for every 1% point increase in fixed telephone subscriptions as a percentage of the population, the Human Wellbeing index will increase by 1.54. Similarly, the coefficient for 'Time to enforce contract' of -0.0059 suggests that if it takes a long time to enforce contracts, the Human Wellbeing index will decrease. Data-driven narratives may help in this case as they may help to present this data (Sharma *et al.*, 2020). Some of the data may be confusing but data-driven narratives solve this problem by making comparisons and conclusion.

In our research, we also compared Uganda with countries that are similar in terms of geographical region and previous human development status. Initially, the indicators from each category/pillar are compared with the different countries against their Human Wellbeing index (Ministry of Information and Communications Technology, 2011). For example, the number of mobile subscriptions was on the rise in Uganda, but when compared to other countries, Uganda's growth in this is also minimal. Even though there was a rise in the number of mobile subscriptions, the Human Wellbeing dimension has experienced a downfall from 2012

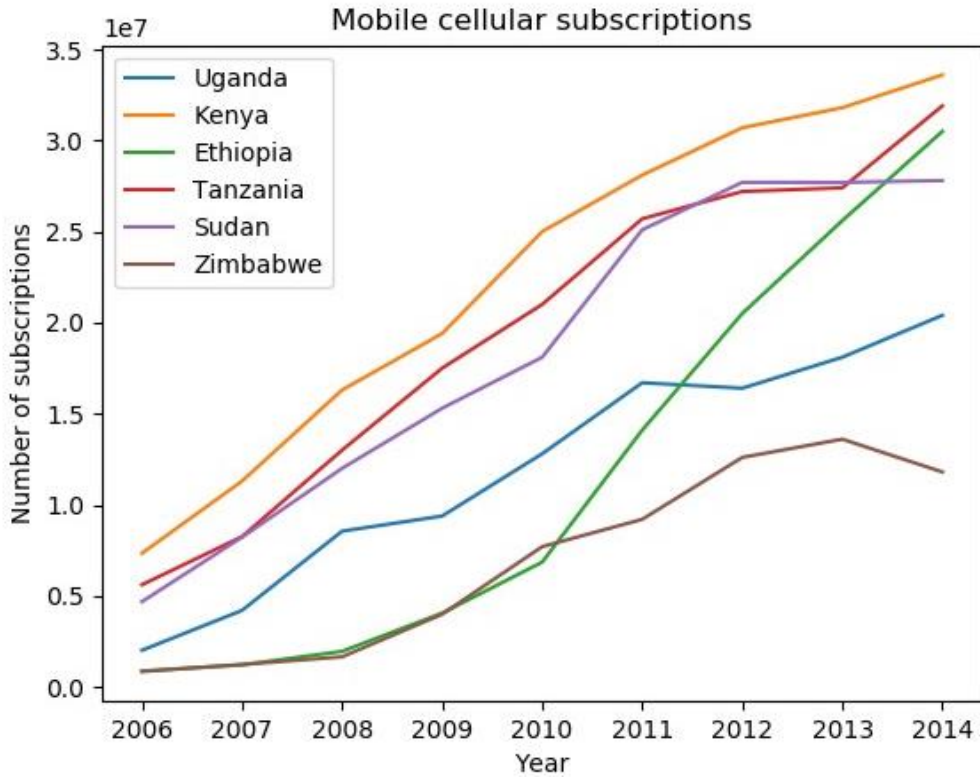

Figure 8: Mobile Cellular Subscriptions across African Countries.

This shows that the growth in the ICT sector did not have any positive effect on the sustainability of Uganda in the last few years. The other significant change in Uganda during these years was the increase in corruption. Uganda is one of the most corrupt countries, placed at 151st out of 176 countries. The control of corruption is the indicator used here to analyse its effect on the SSI; the Human Wellbeing dimension of SSI tends to have its effect from the lack of control in corruption.

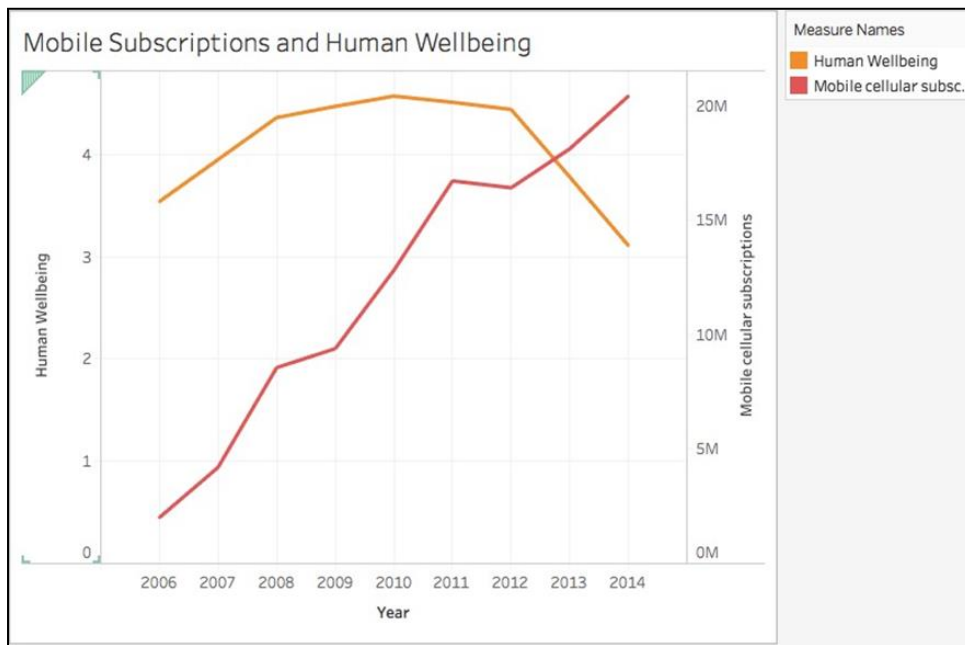

Figure 9: Human Well-being & Mobile Cellular Subscriptions Trend.

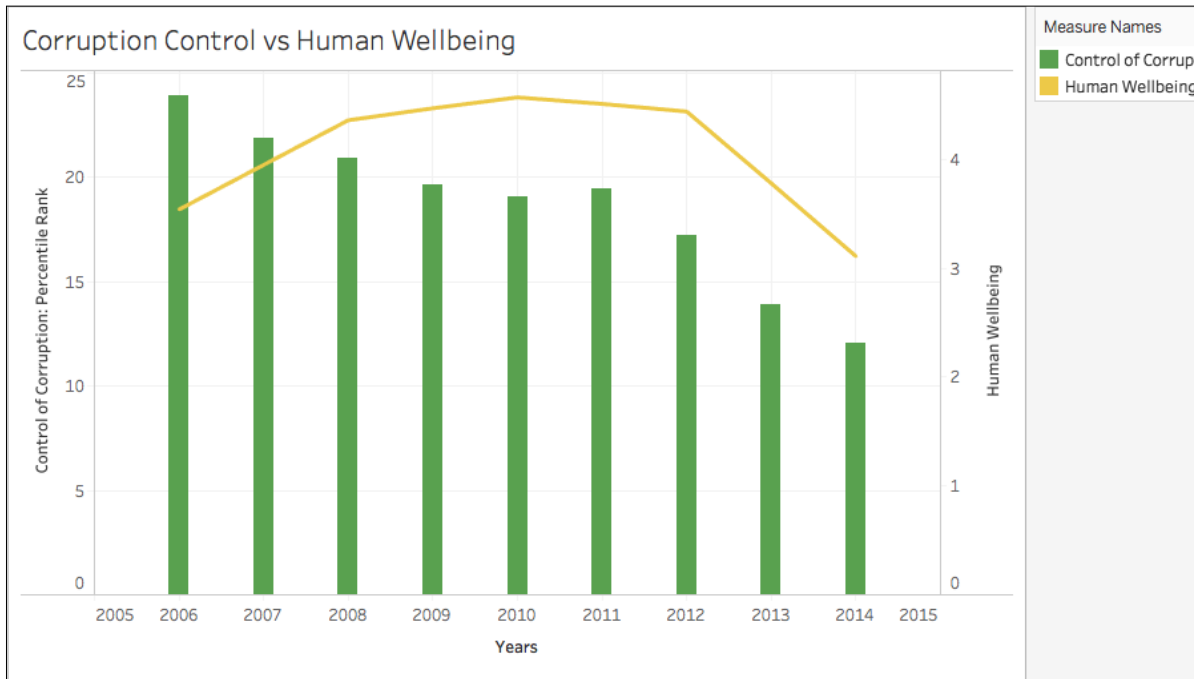

Figure 10: Corruption Control & Human Well-being across African Countries.

Key Implications for Policy:

Three key findings may be derived from modelling and analysis. 1) Uganda’s socio-economic development, as described by the SSI, has been stagnant in recent years. 2) Even though we expected ICT to have a large (statistically significant) effect on socio-economic development, we found that this was not the case. 3) The linear model we have created has limitations, but we have found that ICT does have a small (but nominal) effect on Human Wellbeing. As noted in the above analysis, Uganda saw a large increase in ICT investments, specifically in infrastructure, governance, human capital and innovation. This is entirely consistent with key benchmarks from OECD countries (Sharma *et al.*, 2013). However, Human Wellbeing was on a decline since 2012. Looking at other contributing factors, we suspect the corruption and civil war in Uganda to have played a significant role. This counteracts the effects of ICT on social sustainability. This idea is strengthened by the fact that the ICT industry contributes to a mere 6% of its total GDP. This is a red-flag and a lesson learnt that could be instructive for other developing nations whose priorities could be fundamental – nutrition, housing, security, education, health etc.

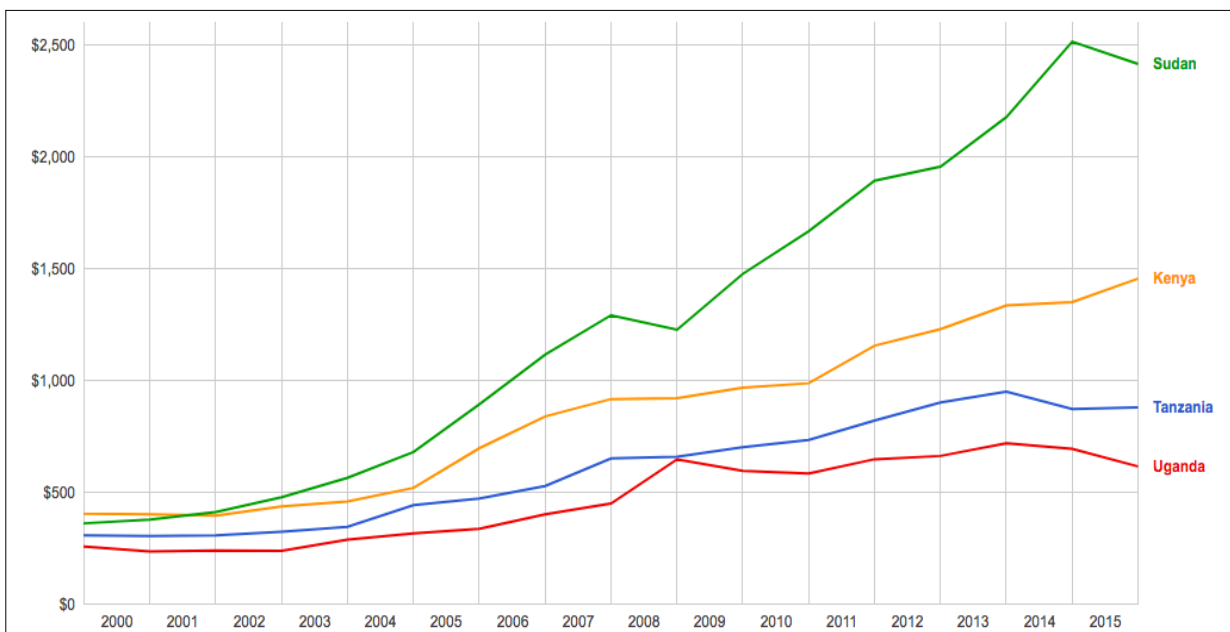

Figure 4: Long term view of Uganda's Economy.

Figure 11 illustrates the growth rate of Uganda relative to similar countries. While Sudan, Kenya, Tanzania, and Uganda all started with a similar GDP per capita in 2000, by 2014, Uganda did not even reach a quarter of Sudan.

Narrative of Trends

Juxtaposed with the above narratives are noteworthy global trends that serve as caveats to the Ugandan growth story.

- The increased affordability of mobile phones and airtime have contributed to the low use of public payphones.
- Fixed-line internet subscriptions are going the way of fixed voice, but the growing availability of internet-enabled mobile devices is increasing internet access.
- The infrastructural capacity of operators will be challenged by increased internet use.
- Mobile money is now the primary method of sending money from one person or place to another.
- Access to customer data has enabled global e-commerce players such as Alibaba to develop creative ICT products.
- The coupling of mobile money services with disruptions of IP-voice services is attracting new over the top (OTP) services.

CONCLUDING REMARKS

To recap, the effect of ICT on sustainable growth on Uganda has been ambiguous at best. This is in stark contrast to its outcome in other African and developing countries. A plausible reason for this anomaly could be that ICT policy has been poorly implemented. That is, while the indicators of access (Internet, mobility, and perhaps even affordability) may have been put in place to encourage usage, the participation and human development of Ugandans may not have taken place. Sharma (2018) attributes this to the lack of the phenomenon we call digital mis-transformation. This alludes to the notion that, despite significant investments in digital infrastructure and governance legislation, persisting knowledge disparities hinder more inclusive growth and development. After all, the multiplier effect and monte-carlo transformations across sectors of society presume a certain level of capability development and absorptive capacity. The current government of Uganda very seriously needs to think and design a set of platforms, applications and community strategies to enjoy the network effects of a digital knowledge society (Sharma *et al.*, 2016).

The case of Uganda, therefore, sadly, reminds academics and policy-makers that ICT indicators by themselves do not necessarily lead to desirable sustainable growth outcomes. The ICT penetration variables such as mobile phones and internet have positive and significant impact on current year's growth process Chatterjee (2020). Hassan (2005) and Goaid (2013) illustrated that ICT is an important part of economy's development process; it improves the productive capacity and competitiveness by connecting the country with the rest of the world. But, for low-income countries such as Uganda, the rapid accumulation of ICT may increase poverty and income inequalities because it eliminates unskilled workers and excludes poor people from workforce since they are not well furnished and qualified. That may have a negative impact on growth.

There is a missing piece comprising digital literacy and participation that calls into question the mediating role of inclusive growth. It is evident that wide access to ICT and capacity development are necessary building blocks of leveraging ICT. We are hopeful that such positivist narratives may be developed in future.

REFERENCES

- [1] Avgerou, C. (2010). Discourses on ICT and development. *Information Technologies and International Development*, 6(3), 1-18.
- [2] Buntaine, M. T., & Daniels, B. (2020). Combining bottom-up monitoring and top-down accountability: A field experiment on managing corruption in Uganda. *Research & Politics*, 7(3), 2053168020934350.
- [3] Bowles, M. (2013). The critical role of e-skills in raising NBN adoption and Australia's competitiveness in the global Digital Economy. *Telecommunications Journal of Australia*, 63(1), 10-1.
- [4] Chatterjee, A. (2020). Financial inclusion, information and communication technology diffusion, and economic growth: a panel data analysis, *Information Technology for Development*, 26(30), 607-635, DOI: 10.1080/02681102.2020.1734770
- [5] Conrath, D. W., & Sharma, R. S. (1990, September). Towards a diagnostic instrument for assessing the quality of expert systems. In *Proceedings of the 1990 ACM SIGBDP Conference on Trends and Directions in Expert Systems* (pp. 72-87).
- [6] Desai, M., Fukuda-Parr, S., Johansson, C., & Sagasti, F. (2002). Measuring the technology achievement of nations and the capacity to participate in the network age. *Journal of Human Development*, 3(1), 95-122.
- [7] Gillwald, A., Mothobi, O., Ndalana, A., & Tusubira, T. (2019). The state of ICT in Uganda. *Research ICT Africa*. Available from https://researchictafrica.net/2019_after-access-the-state-of-ict-in-uganda/
- [8] Kasigwa, J., Williams, D., & Baryamureeba, V. (2006). The role of ICTs and their sustainability in developing countries. *Measuring Computing Research Excellence and Vitality*, 78-88.
- [9] Kraay, A., Kaufmann, D., & Mastruzzi, M. (2010). *The worldwide governance indicators: methodology and analytical issues*. The World Bank, 220-246.
- [10] Ministry of Information and Communications Technology (MOICT). (2011a). Information Management Services Policy: Draft V.8, February, available at: <http://www.nita.go.ug/uploads/>

- [11] Ministry of Information and Communications Technology (MOICT). (2011b). National Information Security Strategy (NISS), March, available at: <http://www.nita.go.ug/uploads/NISS>.
- [12] Ministry of Information and Communications Technology. (2010). The transition from Internet Protocol Version 4 (IPv4) to Internet Protocol Version 6 (IPv6) Policy (Draft). Retrieved from [http://www.nita.go.ug/uploads/IPv6_DRAFT_POLICY\(1\).pdf](http://www.nita.go.ug/uploads/IPv6_DRAFT_POLICY(1).pdf)
- [13] Mwesige, P. G. (2004). Cyber elites: A survey of Internet café users in Uganda. *Telematics and Informatics*, 21(1), 83-101.
- [14] Ndiwalana, Ali, and Tusubira, F.F. (2012). Understanding what is happening in ICT in Uganda. A supply and demand-side analysis of the ICT sector. *Evidence for ICT Policy Action*, Policy Paper 8.
- [15] Palvia, P., Baqir, N., & Nemati, H. (2018). ICT for socio-economic development: A citizens' perspective. *Information & Management*, 55(2), 160-176. <http://dx.doi.org/10.1016/j.im.2017.05.003>
- [16] Sharma, R. (2018). R. Sharma, Revisiting the knowledge Gini coefficient: Digital literacies and sustainable development. *IEEE IT Professional*, 20(5), 91-95. doi: 10.1109/MITP.2018.053891343
- [17] Sharma, R. S., Iqbal, M. I. N. A., & Victoriano, M. M. (2013). On the use of benchmarking and good practices for knowledge management for development. *Knowledge Management Research & Practice*, 11(4), 346-360.
- [18] Sharma, R. S., Samuel, E. M., & Ng, E. W. (2009). Beyond the digital divide: Policy analysis for knowledge societies. *Journal of Knowledge Management*, 13(5), 373-386.
- [19] Sharma, R. S., Ng, E. W., Dharmawirya, M., & Keong, Lee, C. (2008). Beyond the digital divide: A conceptual framework for analyzing knowledge societies. *Journal of Knowledge Management*, 12(5), 151-164.
- [20] Sharma, R. S., Ng, E. W., Dharmawirya, M., & Samuel, E. M. (2012). A policy framework for developing knowledge societies. In *Trends and Effects of Technology Advancement in the Knowledge Society* (pp. 24-49). Hershey, NJ: IGI Global.
- [21] Sharma, R., Fantin, A. R., Prabhu, N., Guan, C., & Dattakumar, A. (2016). Digital literacy and knowledge societies: A grounded theory investigation of sustainable development. *Telecommunications Policy*, 40(7), 628-643.
- [22] Sharma, R., & Ravindran, T. (2020). *The Epistemological Basis for Constructing Data-Driven Narratives*. Cambridge Open Engage Preprint. <https://doi.org/10.33774/coe-2020-v0cfc>.
- [23] Sharma, R. S., & Wildman, S. (2009). The economics of delivering digital content over mobile networks. *Journal of Media Business Studies*, 6(2), 1-24.
- [24] Ssewanyana, J. K. (2007). ICT access and poverty in Uganda. *International Journal of Computing and ICT Research*, 1(2), 10-19.
- [25] Ssewanyana, J., & Busler, M. (2007). Adoption and usage of ICT in developing countries: Case of Ugandan firms. *International Journal of Education and Development using ICT*, 3(3), 49-59.
- [26] Trading Economics (2019). Uganda corruption rank. <https://tradingeconomics.com/uganda/corruption-rank>
- [27] UNDP (2020). *Human Development Indicators*. <http://hdr.undp.org/en/countries/profiles/UGA>
- [28] Waema, T. M., & Miroro, O. O. (2014). Access and use of ICT and its contribution to poverty reduction in Kenya. *ICT Pathways to Poverty Reduction: Empirical evidence from East and Southern Africa*, 102-131.
- [29] World Development Indicators, 2016. (n.d.). Retrieved from <https://issuu.com/world.bank.publications/docs/9781464806834?e=0%2F35179276> (December 1, 2020).

Research on User Resistance Behavior in the Post-Implementation Stage of a Hospital Information System

(Full Paper)

Peilei Fu, Foreign Trade & Business College of Chongqing Normal University, Chongqing, China, fpl515@163.com

Hongjiao Fu, School of Information, Renmin University of China, Beijing, China, fuhj@ruc.edu.cn

Liang Zhou*, School of Public Administration, Sichuan University, Chengdu, China, zhouliang_bnu@163.com

Ying Zhao, School of Public Administration, Sichuan University, Chengdu, China, zhaoying@suc.edu.cn

ABSTRACT

The development of informatization brings great opportunities for the construction of informatization in hospitals. Hospitals are increasingly dependent on information systems. However, in the process of implementing the hospital information system, user resistance has become an important factor hindering the successful implementation of the system. The existing researches on the causes of user resistance mostly stay in the pre-implementation stage before the introduction of the system. However, the pre-implementation stage does not involve the resistance caused by users' real contact with the system, so the research conclusions are limited. Based on the existing three-factor resistance theory, choosing the resistance in the post-implementation stage of a hospital information system as case study object, starting from the three theoretical perspectives, this paper makes a comprehensive analysis of the reasons for the resistance behavior in the post-implementation stage of the information system, and puts forward that the reasons for the resistance behavior are caused by user motivation, system development technology, network infrastructure, organizational support, organizational management, and other comprehensive caused by multiple factors. Through this study, the conclusions of the existing information system resistance factors research field are further expanded and improved, making the conclusions more comprehensive and specific. This paper not only provides theoretical reference for researchers in related fields, but also provides substantive suggestions for the smooth implementation of information system in hospitals, promotes the transformation of hospital informatization, and improves the level of medical service and social health.

Keywords: User resistance factor, hospital information system, post-implementation stage, three-factor resistance theory, case analysis.

*Corresponding author

INTRODUCTION

Health, an eternal topic of human beings, was placed at the center of sustainable development by the United Nations in 2015, and medical organizations and healthcare services play a crucial role in promoting human health (Liu & Mao, 2019). As professional service institutions to maintain human health, hospitals aim to provide active medical services to people in need and improve the health level of the whole society (Manzoor *et al.*, 2019). In recent years, with the support of many emerging information technologies, hospitals have been carrying out reform and innovation to improve medical conditions and social health level. The continuous mature development of information technology has brought new opportunities for the development of medical informatization. Medical informatization has become an important trend in the economic development of various countries and is the core force of social and economic reform. In 2008, the president of the United States proposed that strengthening the construction of medical information technology is an important frontier to achieve the reform of health care system. He suggested to invest 50 billion US dollars in the development of the electronic system of medical information technology (Liu, Guo & Zhao, 2013). In May 2012, the ministry of health in the United Kingdom released a strategy report, which set out the action for medical informatization in the next decade. China has also issued a number of relevant policies and norms, such as "the healthy China 2020 strategic research report" and "the guidance on the construction of health informatization and the preliminary development plan (2011-2015)". In the period of "13th five-year plan", the medical and health industry is taken as the key object of informatization development, and is included in the key plan of informatization construction and national network security.

Practice has proved that under the background of the continuous improvement of the level of social science information technology, medical informatization in all countries is developing rapidly, and medical information system is the indispensable infrastructure for medical organizations to carry out information reform. The implementation of information system in the hospitals can gradually improve the internal competitiveness of hospitals, improve the patient's medical experience and satisfaction, improve the quality of medical service, which lay a foundation for the improvement of doctor-patient relationship and provide important guarantee for the long-term development of the hospital, and promote public health to a new level.

However, in the process of realizing medical informatization, the implementation of hospital information system is confronted with the problem of user resistance, which has become the biggest obstacle to the successful implementation of information system (Kim, 2011). Because the implementation of information system is accompanied by changes in work content, working mode and even in organizational structure, organizational culture and organizational system, when users are worried and anxious about these changes, they will refuse to use the system, delay the implementation cycle of the system or make the new system not fully utilized, etc (Beaudry & Pinsonneault, 2005). The phenomenon that users resist the implementation of information system has become a new problem concerned by researchers in related fields (Klaus & Blanton, 2010; Adams, Berner, & Wyatt, 2004).

User resistance is the biggest obstacle to the successful implementation of information system. Some scholars have conducted researches on the causes of the resistance behavior in the implementation of information system. These researches mainly include two aspects. Part of the researches starts from the phenomenon of user resistance, focusing on the description of the phenomenon, but the lack of theoretical explanation. Researchers only carry out observation records for a certain field or specific phenomenon, and directly propose some factors that may influence the resistance behavior based on the results of individual observation (Kim & Kankanhalli, 2009). The other part of the researches reveals the causes of the resistance behavior from the perspective of the information system users themselves. Compared with the researches directly putting forward the resistance factors that lack the theoretical basis, the theoretical model provides a more solid theoretical research (Gang, 2011), and its research conclusion is more convincing as well. Based on the equity theory, Joshi (1991) studied the individual's resistance to the change of the rights and interests caused by the implementation of information system. Lapointe and Rivard (2005), based on the semantic analysis of the resistance study, came to the conclusion that "the reason for the resistance is that the introduction and implementation of the system makes the system users feel the potential threat and make them anxious, which leads to the resistance of users to the system". From the perspective of emotion theory, Marakas and Hornik (1996) explored the reasons for the formation of user resistance and proposed that when users felt that the introduction of information system would bring pressure and fear on them, they would produce some resistance behaviors. Martinko *et al.* (1996) explained the resistance behaviors based on the attribution theory, believing that users would make attributions to the impact of the implementation of the information system, which would lead to users' expectation of the results, and when the expectation was negative, the behaviors of resisting the implementation of the system would be generated. In addition, some domestic scholars have established the user resistance model based on behavior factors to analyze the factors of user resistance (Wu, Chen & Li, 2008).

However, the above researches mainly focus on the user's resistance behavior in the pre-implementation stage of information system, and seldom discuss the resistance behavior after the implementation of information system. System implementation includes pre-implementation stage and post-implementation stage. The pre-implementation stage refers to the period from the deployment of the system to the pre-use period, with specific tasks including personnel training, purchase, installation and debugging of computers and other equipment. The post-implementation stage refers to the period when the system is put into operation and users can really use the system (Marakas & Hornik, 1996). In fact, the user's resistance to the information system may occur at any stage of the system implementation (Martinko *et al.*, 1996). In the pre-implementation stage, because the users have not really contacted the system, the main reason for the resistance behavior is the users' subjective cognition of the future uncertainty (Beaudry & Pinsonneault, 2005; Klaus & Blanton, 2010; Kim & Kankanhalli, 2009). However, in the post-implementation stage, users have already had real contact with the system, the uncertainty before the implementation has disappeared, and the resulting pressure and anxiety have also changed. Therefore, the existing theories proposed in relevant researches are insufficient to explain the resistance of users to the implementation of information system in the post-implementation stage. In addition, most of the above theories about resistance behaviors focus on the individual level of users and ignore the factors of users' surrounding environment. Human behaviors are response to the stimulus of the surrounding environment, so the role of the environment must be considered when exploring human behaviors. Therefore, the external environment of the users and the interaction between the users and the environment should be considered when studying the user's resistance behaviors in the implementation of information system. In addition, the reasons for users' resistance will vary in different types of organizations and to different types of information systems (Jiang, Muhanna & Klein, 2000). Therefore, it will make the research more targeted to analyze the reasons for the resistance behaviors in a specific organizational context. Most of the previous studies focused on the implementation of information systems in for-profit enterprises, mainly the implementation of ERP systems, while few studies focused on the information system user resistance behavior in other types of organizations. Taking the medical information system as an example, the informatization development of the medical industry has become the focus of current attention, and the medical organizations are increasingly dependent on the hospital information system. There are a large number of public hospitals in China, which derive their revenues from provided services and from the large sums of money received from the government. In the process of operation, they are not purely for the purpose of profit, but need to undertake a large number of social services. Therefore, such public hospitals are different from traditional enterprises, which are not purely profit-oriented organizations. The purpose of their information system implementation is also different from that of traditional enterprises. In the implementation process, on the one hand, they should not only consider how to serve the internal management of the organization, but also consider how to serve the patients who come for medical treatment and assume social responsibility. In addition, most of the members in the hospital organizations are personnel with professional skills and each department is a relatively independent department with very professional knowledge, so the internal management of the hospitals is also a specialized discipline different from enterprise management. Therefore, the environment in which the hospital information system is implemented also has certain

particularity. To explore the issues of user resistance in the implementation of information system in hospitals will help medical organizations accurately grasp the resistance factors, take targeted measures to solve the existing resistance problems, remove obstacles in the implementation of the medical information system, promote the smooth development of the medical systems and improve the level of medical services.

Therefore, this study tries to solve the following questions: what factors can cause the resistance of medical staff to the hospital information system in the post-implementation stage? In order to solve the above problem, based on the summary of the relevant research status and the three-factor resistance theory, this paper extracted, coded and abstracted the influencing factors of the resistance behaviors in the post-implementation stage of the hospital information system from the perspective of user, system and human-system interaction. After discussion and analysis, the paper puts forward the specific reasons for the user resistance behaviors in the post-implementation stage of the hospital information system.

THEORETICAL FRAMEWORK

Through the summary of related domestic and foreign literatures, it can be found that the theories of user resistance mainly include three-factor resistance theory, equity theory, attribution theory and status quo bias (SQB) theory (Martinko *et al.*, 1996). The three-factor resistance theory is the theoretical basis of this study.

The three-factor resistance theory proposed by Marakas (1996) is the most classical theory in the field of resistance behavior research, which explains the user's resistance behaviors from the perspectives of system-oriented, human-oriented and human-system interaction theory (Xing, 2015). The system-oriented view holds that the reasons for the resistance behaviors are related to the factors related to computer technology and communication technology, specifically, the design of the system, and the quality of the system design determines whether the users will have the resistance behaviors. The human-oriented view holds that the resistance is caused by the characteristics related to the users themselves, such as values, emotions, educational background, knowledge and attitude towards information technology, etc. The human-system interaction theory emphasizes that the individual users will interact with the system in the process of implementing the information system, and such interaction will cause the change of power distribution in the process of system implementation, and the party whose power will be lost will resist the implementation of the information system. These three views are also different from each other because of the different theoretical perspectives that explain the causes of user resistance.

The main reasons for selecting the three-factor resistance theory as the theoretical basis for this study are as follows:

Firstly, the three-factor resistance theory provides a more comprehensive research framework for us to understand and analyze the user's resistance behaviors. It can be found from the above summary of the reasons for resistance that all the reasons for resistance based on the existing empirical researches contain the ideological viewpoint of the three-factor resistance theory. However, the existing research results only reflect a certain point of view of the theory, which have not fully reflected the comprehensiveness and advantages of the theory in explaining the causes of users' resistance. In the post-implementation stage, in addition to the resistance behaviors caused by the user's own factors, it also involves the resistance behaviors caused by the system characteristics, as well as the resistance behaviors caused in the process of the interaction between people and the system. In order to fully explore the causes of resistance in the post-implementation stage of the system, the three-factor resistance theory is a good choice.

Secondly, the three-factor resistance theory is the theoretical basis proposed from the organizational level. Some researchers have proposed that individual resistance is not enough to cause too much impact on the whole implementation process or lead to the failure of the system, so it is more meaningful to study group resistance behaviors (Adams, Berner, & Wyatt, 2004). This study is aimed at the resistance research of organizational level. By using the resistance theory and analyzing the causes of resistance from three perspectives, this paper will study the resistance behaviors from the organizational level.

Therefore, taking the three-factor resistance theory as the basis for theoretical construction, this study conducts an all-round analysis of the reasons for the resistance from the three perspectives proposed by the theory, and proposes more comprehensive reasons for the resistance in the post-implementation stage of the system, so as to provide practical reference for relevant researchers and users.

RESEARCH METHODS

As one of the main research methods of social science, case study is an effective tool to understand the objective world and deal with complex problems, which can effectively reveal the reasons behind complex phenomena by in-depth and comprehensive field investigation of a certain problem in reality, obtaining detailed data and analyzing the data under the guidance of theory. Yin (2017), who has studied the case study method in depth, and other senior scholars of the case study method all agree that it is appropriate to use the case study method to answer the "how" and "why" questions. The purpose of this study is to answer the questions such as why user resistance phenomenon arises and how to better avoid the resistance behavior in the process of system implementation, so the case study method is applicable. At the same time, compared with multiple case studies, single case study is more suitable for in-depth analysis and exploration of a certain problem, which can explore very deeply the case phenomenon to extract the theory or law that can reveal the complex phenomenon (Eisenhardt, 1989).

Case Selection

In order to ensure the feasibility and effectiveness of the later data collection, the selection of case study samples is a very important step. Before the case selection, this study theoretically proposed a set of reference standards, which should be followed in case selection. First, the selected cases should be representative and reflect the actual situation of the hospital in the process of implementing the information system. Second, the selected cases should have carried out the construction of informatization and have the experience of system implementation. Third, for the feasibility and convenience of data collection, managers and medical staff in the organization where the selected cases are located should actively cooperate with the research and provide researchers with a large amount of real data.

Based on the above criteria, this study finally selected a grass-roots hospital in Chengdu city of Sichuan Province in China as a case sample. First, the reason for choosing this hospital was not only that it is located in the urban area of Chengdu city, which is convenient for researchers to come to the hospital for field research and interview at any time, but also a consensus has been reached that they are willing to cooperate with the investigation process and provide the required data for the researchers after early communication with the hospital manager. Second, the hospital has been constructed information platform in order to response to the call of medical informatization, and information system used in the hospital was constantly updating and replacing information systems due to the development of technology and changing needs. During the research period, the hospital was implementing a new information system, which was in the post implementation stage, in line with the research situation. Finally, in the process of implementing the new system, the hospital was faced with many difficulties in promoting the new information system due to the replacement of the old and new systems, such as medical staff not cooperating with the implementation of the system, complaining loudly, or even not using the system, etc., which are typical user resistance behaviors and are consistent with the problems of this study. Based on the above reasons, this grass-roots hospital was taken as the research object to deeply analyze the reasons for the resistance behaviors of medical staff in the implementation stage of the hospital information system.

The new system being implemented at the hospital is the family doctor contract signing service system for health management. Family doctor service is a concept put forward in the process of deepening the reform of medical and health system and promoting health management, which is a kind of health management service mode that changes the traditional mode of doctor's sit-in, embodies the people-centered mode, provides all-round and active health management service through long-term contract signing service with patients, and pays more attention to prevention while treating, so it can effectively improve national health management level. The grass-roots hospital in this study actively responded to the family doctor contract signing service policy by continuously promoting the family doctor contract signing service. The hospital also invited Dr. J from a university in the United States to the community hospital for an exchange of experience in health management. In the process of exchange, the importance of information means in the process of contract service was emphasized. Therefore, in order to better provide family doctor contract signing services, while the hospital was vigorously carrying out contract signing services, it also attached great importance to involvement of informatization, hoping to improve the quality and efficiency of contracted services through information tools and win the recognition and satisfaction of the majority of residents. To this end, the hospital leadership finally selected a software development company to develop a family doctor contract signing system after a variety of inspection and consultation. However, after the software development company delivered the contract signing system to the hospital and completed the installation and debugging in the pre-implementation stage, it encountered many difficulties and obstacles when the system was put into operation and used in the community hospital. In the process of using the system, the medical staff reported many system problems or vulnerabilities, which led to their complaints and negative feelings, and even an unwillingness to continue using the system. Faced with this situation, the software development companies could not find other solutions except to try to make up for the loopholes, which made the community hospital leaders very distressed. The hospital hopes to find out the underlying reasons and promote the implementation of the system smoothly.

Data Collection

Yin (2017) proposed that in the process of case study, data materials are from six sources: literature, interviews, direct observation, archival records, participatory observation and physical evidence. In order to ensure the comprehensiveness and rigor of data collection, this study took interviews as the main source of data, supplemented by direct observation and inquiry of archival records.

In order to ensure the smooth conduct of the interview, before the formal interview, the interview outline was designed in detail according to the theoretical basis of the research, and the resistance performance of users was investigated from three dimensions of human-oriented, system-oriented and human-system interaction orientation (see Appendix). The respondents included doctors and nurses who used the system directly. In this interview, a total of twenty medical staff, including 10 doctors and 10 nurses, were interviewed, all of whom have worked for more than 5 years in the hospital. Among the ten doctors interviewed, 7 had bachelor's degree or above, and the other 3 had college degree, while ten nurses had college degrees or above. During the interview, each respondent was interviewed for more than half an hour, and eventually more than 800 minutes of interview recordings were obtained. More than 15,000 words of interview records were obtained by collating the recordings. At the same time, in addition to face-to-face communication with the respondents, we also kept in touch with the respondents throughout the research process to facilitate return visits and repeated communication and confirmation of certain issues.

Data Analysis Method

The data materials in the case study belong to qualitative data, so this study uses the qualitative data analysis technique proposed by Orlikowski (1993), which is the way of combining multi-level data coding with theoretical framework. The specific steps of analysis are as follows:

The first step is open coding to form an entry library. Through the careful arrangement and reading of the original interview materials and the materials obtained through observation and archival records, the open coding results are formed on the basis of respecting the original data, and each entry is identified with the original data vocabulary to identify the resistance behavior and performance in the process of system implementation. The statistical results are shown in Table 1.

Table 1: Statistical results of open code entries number

Data source	Data classification	Number of entries (unit: article)
First-hand materials	Data obtained from in-depth interviews	242
	Data obtained by direct observation	7
Second-hand materials	Data obtained through archival records	14
Total		263

The second step is to induce the first-level code. The surface structure analysis of the case material is conducted on the basis of open coding (Pan & Mao, 2010). That is, by carefully comparing the words repeatedly mentioned by the respondents in the open coding results, rebuilding the event process with their words, and coding in stages, the first-level concept coding can be induced.

The third step is to induce the second-level code. While doing the first-level coding, this study tries to find the relationship between these first-level codes and explore their potential correlation based on the relevant literatures in the research field of user resistance. Through the analysis of the specific performance and characteristics of the resistance behaviors, the deep-seated reasons for users' resistance are analyzed and explained. The specific coding results are shown in table Table 2.

The fourth step is to do summary coding. The work of this process is to logically group the second-level coding results with summative concept, and to summarize and explain the results from the three perspectives of human-oriented, system-oriented and human-system interaction theory in combination with the preliminary theoretical framework.

RESEARCH FINDINGS

Through the analysis and exploration of the implementation of the medical information system in a grass-roots hospital, it is found that a series of changes caused by the implementation of the system lead to the resistance of the medical staff to the system and the reasons for the behaviors.

Resistance Performance

The completion of a series of preparatory work indicates that the hospital's contract signing system will be officially put into operation. In the early stage after the configuration of parameters and operating environment and the installation of function modules, the main performances of users are not interested in the system and do nothing, such as spending little time to learn how to use the system, not being active in system training meetings, etc. The introduction of the contract signing system meant that paper records of signed patients were replaced by electronic records. This community hospital had a large number of contracted patients before the introduction of the contract signing system and medical staff need to enter their paper files into the system when using the contract signing system, which will greatly increase the workload of medical staff. In addition, some basic information of patients is recorded in the public health systems, but since the public health systems and the contract signing system do not realize data sharing, it is necessary to re-enter these patients' basic information into the contract signing system, also resulting in heavy workload of medical staff.

"In order to improve the quality and efficiency of health management, the hospital introduced the contract signing system, but due to the tedious work of data entry, my workload was increased. Moreover, I not only need to finish other work well, also need to consider the use of the new contract signing system, the work content also increased." Said one of the nurses interviewed. (Nurse: No. 5)

This example shows that the real interaction with the contract signing system makes the medical staff feel the experience of using the system. The introduction of the system makes the medical staff feel the increase of workload and work content, which leads to their reluctance to use the system and resistance to the system.

After the contract signing system has been in operation for a period of time, the respondents were gradually familiar with the operation and use of the system, and began to understand its functions. There were some changes in resistance behavior among

respondents. For doctors, after a period of getting familiar with the system, they found that the system is just to realize the informatization of family doctor service mode, the current system is just completing the archives informatization and did not achieve innovation or intelligent on the function. Although the system could basically meet the needs of the work, it did not bring more achievements to the work, which made the doctors feel that the existence of the system did not mean much, so they were still indifferent to the system.

Although adding another system has no impact on the work of doctors, it has a great impact on nurses as the system is further used. Since doctors only use the system for diagnosis and treatment and the recording of some important information, the general data entry work is done by nurses, so the workload of nurses increases a lot. At this time, the nurse's resistance to the system turned into a negative resistance, resulting in complaints against the system, delaying the use of the system and other behaviors. At this stage, nurses often complained about the unstable system, tedious data entry and heavy workload of repeated entry, and the respondents' reluctance to use the system was enhanced by the complaints and negative emotions of their peers.

"The new contract signing system increased our workload, but the working hours were only a few hours, so I couldn't finish my work in the normal working hours and had to work overtime by myself. Therefore, for this new contract signing system, I only used a few functions and operations that I had to use, and the other functions I tried not to use." Said one of the nurses interviewed. (Nurse: No. 7)

From this example, it is clear to see the respondent's negative emotions and resistance behaviors. In addition, the accumulation of everyone's negative emotions at this stage leads to a relatively negative working atmosphere, which affects people's emotions of using the system and makes them more reluctant to use the system.

Resistance Behavior Analysis

Based on the statistical results of the number of entries obtained in the previous open coding stage, the entries are analyzed. Firstly, the surface structure analysis of entries was conducted, and the first-level codes were summarized by using the vocabulary reconstruction process mentioned repeatedly by the interviewees. Then the relationship between the first-level codes was found, and the second-level codes were summarized. At the same time, a typical reference example was given under each code, and the results were analyzed and explained in detail. Finally, the results of the first-level and second-level codes and the corresponding number of entries under each code in the post-implementation stage were obtained, as shown in Table 2.

Table 2: Coding results and typical reference example in the post-implementation stage

Result of second-level codes (Number of entries)	Result of first-level codes (Number of entries)	Typical reference example
External motivation (29)	Negative expectations (14)	The use of the system increased the workload of medical staff and failed to improve their work efficiency and quality. (Nurse: No. 1-4,6,8-10 and Doctor: No:2,3,7)
	Perceived ineffectiveness (15)	The use of the system did not bring more benefits to the work of the medical staff, nor did it allow the medical staff to learn knowledge through the system that could not be obtained in other ways. (Nurse: No. 3,4,6 and Doctor: No:1-3,5-7,9,10)
Internal motivation (20)	Reform participation (9)	Medical staff did not understand the real purpose and reasons for the introduction of the new system, nor the value of the new system, making them lack the participation to use the system. (Nurse: No. 2,3,5,8 and Doctor: No:1,2,4,6-8)
	Sense of need (11)	The existing working mode could meet the working needs without introduction of new system. (Nurse: No. 1-3,5,7-9 and Doctor: No:1,2,4-7,10)
Technical level (79)	System function (5)	System function was not perfect, software quality was not high, etc. (Nurse: No. 2,6 and Doctor: No:4,5,9)
	System performance (39)	The response time was long, the processing speed was slow, the system could not be restored as soon as possible after the failure, etc. (Nurse:No. 1-5,7,9,10 and Doctor:No:1-3,5,6,8-10)
	System operation (35)	Complex system operation, etc. (Nurse: No.3,7,10 and Doctor: No:3,4,6,8,9,10)
Network infrastructure	Network speed (12)	Slow network speed caused the system page to

(12)		open slowly, etc. (Nurse: No. 3,4,8,9 and Doctor: No:2-6,8-10)
Organizational support (14)	System training (14)	The training provided by the hospital or software development company was not timely and in place, etc. (Nurse: No. 2,3,6 and Doctor: No:1,2,5,6)
Organization management (66)	Task redistribution (26)	After the introduction of the new system, the task division was not clear, resulting in tedious and trivial work content. (Nurse: No. 2-5,7,9,10 and Doctor: No:4,5,7)
	Organizational decision making (23)	Hospitals mandated the use of the contract signing system, and medical staff had to be forced to accept. (Nurse: No. 1-6,9,10 and Doctor: No:1-5,7-9)
	Business Process Reengineering (17)	The current system only copied the functions required by the family doctor service mode to the system, without business process restructuring, and the system operation was not standardized and scientific. (Nurse: No. 2,5,6,10, and Doctor: No:2-4,6,7,10)

According to the three-factor resistance theory, the reasons that cause the users to resist the system should start from three aspects: the characteristics of the users themselves, the characteristics of the system and the changes in the process of the interaction between the human and the system.

Human-oriented view

As an internal psychological factor, motivation has a very important influence on human behaviors. In the post-implementation stage, one of the important reasons for the resistance behaviors cannot be separated from the users' resistance caused by human psychological factors.

Motivation can be further subdivided into internal motivation and external motivation. Through the analysis of case materials, the internal motivation is mainly manifested in the lack of need and participation in the reform of the system by users. For users, they can complete their daily work without introducing the system, so they consider that the introduction of the system is not of great value, and of course they will not accept the new system from their hearts. External motivation is reflected in the negative expectation caused by the fact that the actual use effect of the new system is far from as good as expected after the introduction of the system, and the perceived inefficiency caused by the fact that the use of the system does not make the work of users improve qualitatively.

System-oriented view

The system-oriented view holds that resistance is caused by factors related to information technology. Since after the introduction of the system, the users have the most intuitive experience of using the new system, the reason for the resistance behaviors must be related to the characteristics of the system itself.

Through the classification and coding statistics of the interview data reported by the respondents, we find that the problems reflected about the system itself can be summarized into three aspects: system function, system performance and system operation. There is a marked difference in the number of entries in these three aspects. Among them, there are the least number of entries reflecting system function, only 5 entries, 39 entries reflecting system performance, and 35 entries reflecting system operation, which shows that, for users, the developed system can generally meet their requirements in terms of function, and they pay more attention to the operation of the system and the performance of the system. This result is similar to that of users of other types of systems, because system performance and system operation will affect the user experience, if the experience is not good, it will naturally lead to users' dissatisfaction with the system, which will affect their resistance to the system.

In addition, in the process of summarizing and sorting out the system-oriented case materials, another factor that affects the use experience of medical staff and leads to the resistance to the system is also found, that is, the Internet speed. As the infrastructure of information construction, the service quality of network speed has a direct impact on the user's mood of using the system. When these emotions are negative, they will be unwilling to continue using the system.

Human-system interaction orientation

The human-system interaction theory holds that the resistance in the implementation of information system is determined by the interaction between the system and the users. According to the view of human-system interaction orientation, user resistance will occur in the interaction between people and the system, and the interaction between people and the system takes place in such an environment as the organization, so the characteristics of the organization will affect the interaction between

people and the system, and then resistance will occur. Therefore, the influence of relevant characteristics of the organization on the resistance behaviors is worthy of attention. In the analysis of this case, we find the influence of some factors related to organizational characteristics on users' resistance behaviors.

(1) Task redistribution

Before the introduction of the new contract signing system, doctors and nurses did their jobs in their own right. After the introduction of the contract signing system, although the hospital leaders also assigned the work content and responsibilities related to the contract signing system that doctors and nurses needed to complete, the division of labor was not clear due to the lack of specific and reasonable distribution. Some users have to take on too many tasks, which, in the long run, leads to their negative emotions and reluctance to use the new system or delays in using the system.

(2) Organizational decision making

In order to respond to the informatization, the leadership decides to introduce the relevant information system, and the members of the organization can only passively accept it. As a result of passive acceptance, the medical staff naturally have resistance to the system in the process of using it, in their own words, "Don't use it if you can." Therefore, the system functions are not fully used, and the original intention of introducing the system is greatly compromised.

(3) Business process reengineering

In the interviews with healthcare professionals, we also identified a potentially important factor: business process reengineering. It is an inevitable trend to introduce information system to realize informatization, because organizations hope to improve work efficiency and work quality through information system. However, many organizations have the problem of unclear understanding of business process reengineering when implementing information system, and this case study of hospital information system is also no exception. The hospital simply thinks of information systems as transferring existing work to computer systems. However, the workflow on the computer and the traditional work process is different, in order to run a medical information system well, its business process setting must meet the requirements of informatization, so as to achieve the scientific and rational system. Simply copying existing business onto the system will only lead to defects in system processes and problems in system operation. As a result, the system is not running well, which will affect the experience of the system end users or questions about the functionality of the system, increase users' complaints or strong opinions on the system, and generate resistance to the system.

The phenomenon of user resistance to the use of the system, whether during task redistribution or when the hospital decides to force the use of the system, is caused by the improper management mode and thinking of the hospital. Therefore, organizational decision making, task redistribution and business process reengineering can be summarized as organizational management reasons.

The number of entries in Table 2 also reflects a phenomenon that the total number of entries in system-oriented view is the most among the three views of human-oriented view, system-oriented view and human-system interaction orientation.

This indicates that in the post-implementation stage of the system, as users have intuitive feelings and experiences on the use and operation of the system, the reasons that affect the users' resistance behaviors are more from factors related to the characteristics of the system. The most important factors affecting the resistance behaviors of the users are the factors of system-oriented technology level and network environment closely related to technology level. However, under the technology level as a major indicator, system function is not enough to become the factor that affects the users' resistance, and system performance and system operation can affect the users' resistance behaviors more.

CONCLUSIONS

The continuous improvement of national living standard and the enhancement of health consciousness increase the demand for medical and health services day by day, and health well-being is at the heart of many issues facing our country (Agarwal *et al.*, 2010). With the development of information technology and the push of governments around the world, the development of medical informatization has become an inevitable trend. In the process of medical informatization, the construction of hospital information system is particularly necessary. To solve the problem of user resistance behaviors in the process of system implementation to promote the smooth implementation of the hospital information system has an important impact on improving the hospital's medical service level and social health level and enhancing the hospital's core competitiveness.

By studying the resistance behaviors during the implementation of the hospital information system in the context of the medical industry, this paper comprehensively analyzes the specific reasons for the resistance in the post-implementation stage of the medical information system, and constructs a theoretical model of the system resistance behaviors (as shown in Figure 1). This study is a refinement and practical application of the current three-factor resistance theory, which better explains the reasons for the resistance behaviors of users, and also provides a reference and strategy for solving the problem of resistance behaviors and promoting the implementation of hospital information system smoothly.

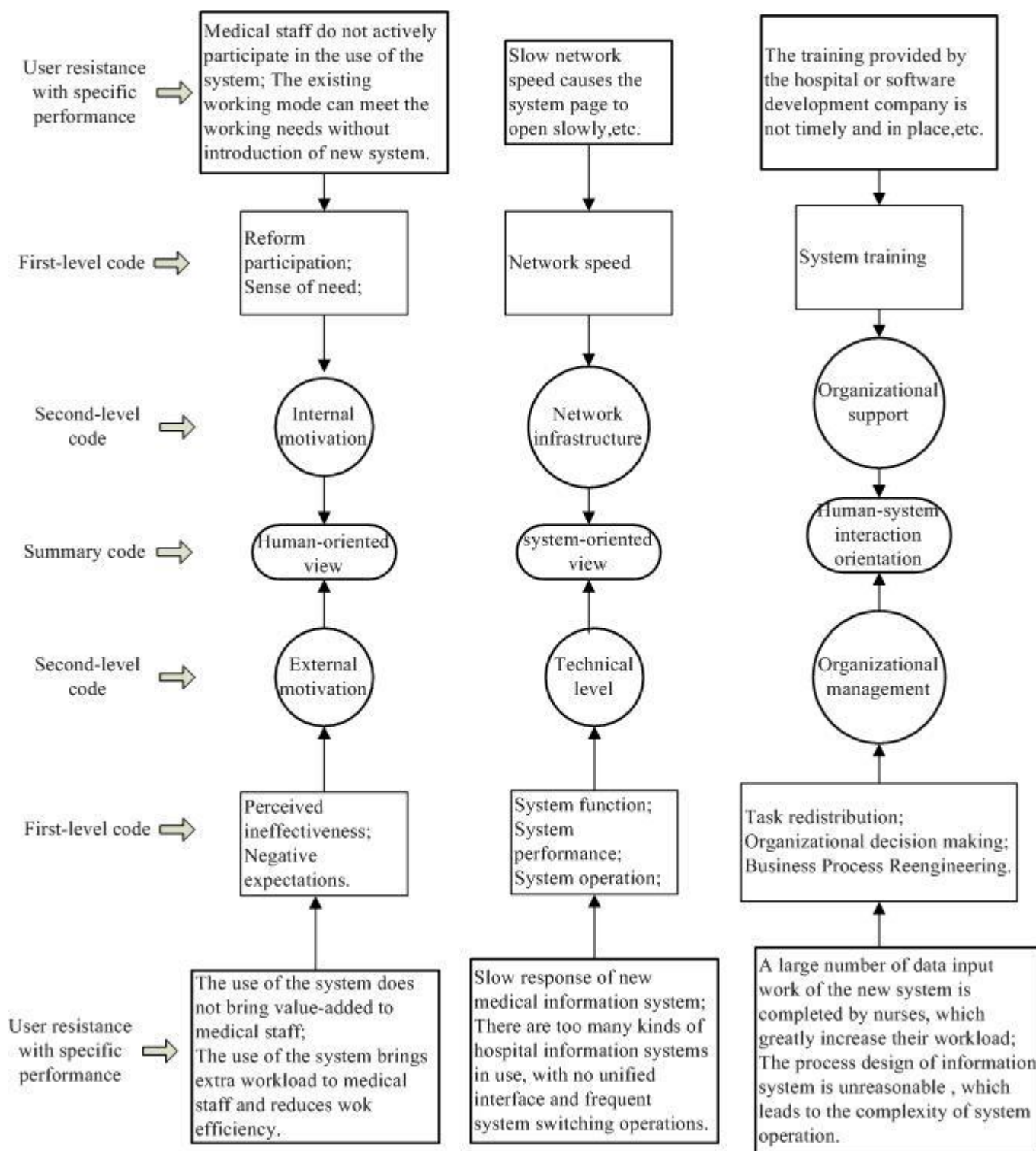

Figure 1: Theoretical model of the system resistance behaviors

It can be intuitively reflected from the theoretical model that human-oriented, system-oriented and human-system interaction orientation all have impact on the user resistance behaviors in the post-implementation stage of the system. In the case of human-oriented, the main reason for the resistance is the explanation based on the user's motivation. In the case of system-oriented, network infrastructure and system development technology will affect the resistance behaviors, among which system performance and system operation are the important reasons for the resistance behaviors. In the case of human-system interaction orientation, organizational management and organizational support become the causes that affect the occurrence of resistance behaviors.

The theoretical contribution of this study is mainly in two aspects. Firstly, based on the three perspectives of the three-factor resistance theory, the paper constructs the interpretation structure model of the users' resistance behavior during the implementation of the information system, which is a further refinement and expansion of the existing three-factor resistance

theory. The existing three-factor resistance theory provides directions for the research of resistance behaviors from three big perspectives including human-oriented, system-oriented and human-system interaction orientation, but the specific reasons for resistance behaviors from each perspective have not been analyzed in depth. This study took the resistance behaviors in the post-implementation stage of the hospital information system as the research object for in-depth analysis, classified and summarized the data obtained, extracted the relationship between each reason and the theory. This study also extended the model that originally provided only three large perspectives to the theoretical model of user resistance with specific performance, first-level code and second-level code, which can be used to explain in detail the reasons of resistance behavior in the post-implementation stage of hospital information system.

Secondly, the theoretical model of resistance behaviors obtained in this study not only includes the reasons for the resistance from the user's own perspective, but also explains the resistance behaviors from the perspective of system and organizational environment. Among the existing user resistance theories, equity theory, attribution theory and status quo bias (SQB) theory mainly focus on the individual level, and propose that the individual's own subjective and objective reasons, such as gender, age, education background, values, motivation, and response to changes in the external environment, etc. result in the resistance behaviors to information system. In this study, since the study situation is positioned at the post-implementation stage of the system in the medical industry, the individual characteristics of system users, such as age, gender, education background and other factors, have no obvious influence on the resistance behaviors, and the resistance behaviors generated by individuals mainly comes from the user's motivation. Meanwhile, because users have real experience of using the system at this stage, the influence of system characteristics on the resistance behaviors is equally important. In addition, because individuals are in the environment of organization, the influence of organizational management and support on users' resistance behaviors should not be ignored. Therefore, according to the specific problems and situations in this study, a theoretical model is constructed by integrating individual, system characteristics and organizational environment. Compared with theories that only explain the resistance behaviors from the perspective of individuals, the theoretical model proposed in this study is more comprehensive and more general, which can provide a comprehensive reference for the interpretation of the resistance behaviors.

The practical value of this paper lies in that, combined with the existing theoretical basis, the most authentic data were obtained through in-depth interviews, and the structural model was constructed completely based on the interview data. The analysis results show that the reasons for the user's resistance behaviors in the post-implementation stage of the system are a series of psychological factors, poor network infrastructure, low technology level, and inadequate organizational support and management after the implementation of the system. Based on the theoretical model obtained in this study, in the process of implementing the information system, the hospital can provide comprehensive support to system users according to the actual situation within the organization, create a good system environment for system users, and relieve users' negative emotions in the process of implementing the system. At the same time, attention should be paid to the technical support of the system to provide users with a good network environment and a system with complete functions and simple operation to improve user experience. By adopting the above strategies to avoid the phenomenon of users' resistance in the process of implementing the information system, the hospital information system can be applied more smoothly, and can be used as an important guarantee of medical informatization, providing people with more convenient, personalized and intelligent medical services, improving the quality of medical services, and helping build a healthy society.

Of course, the study of this paper still has some shortcomings. The case study method is used in this study, so the analysis of the data is mainly qualitative, although a reflective study was carried out in the process of case material analysis, and the meaning of sentences was repeatedly determined with the interviewees through return visits to avoid misunderstanding of case materials, the existence of subjectivity could not be avoided in the analysis of data. In the follow-up study, the number of respondents can be appropriately increased, and the analysis of the pre-implementation stage can be added to understand the reasons for the resistance in the whole system implementation process and its change process. In addition, in the process of data sorting and analysis, joint discussion, repeat thinking, and verification by each other in the process of case interpretation should be added. Through these ways, the existence of subjectivity can be weakened and the analysis results can be more comprehensive, scientific and reasonable.

REFERENCES

- [1] Adams, B., Berner, E. S., & Wyatt, J. R. (2004). Applying strategies to overcome user resistance in a group of clinical managers to a business software application: A case study. *Journal of Organizational and End User Computing (JOEUC)*, 16(4), 55-64.
- [2] Agarwal, R., Gao, G., DesRoches, C., & Jha, A. K. (2010). Research commentary—The digital transformation of healthcare: Current status and the road ahead. *Information Systems Research*, 21(4), 796-809.
- [3] Beaudry, A., & Pinsonneault, A. (2005). Understanding user responses to information technology: A coping model of user adaptation. *MIS Quarterly*, 29(3), 493-524.
- [4] Eisenhardt, K. M. (1989). Building theories from case study research. *Academy of Management Review*, 14(4), 532-550.
- [5] Gang, M. E. I. (2011). Research on development path of management from perspective of rationalism and empiricism. *East China Economic Management*, 25(9), 97-101. doi: 10.3969/j.issn.1007-5097.2011.09.022
- [6] Jiang, J. J., Muhanna, W. A., & Klein, G. (2000). User resistance and strategies for promoting acceptance across system types. *Information & Management*, 37(1), 25-36.

- [7] Jiye, P. M. M. (2010). Effective user participation in ERP implementation: The role of brainstorming sessions. *Chinese Journal of Management*, 7(7), 1052-1063.
- [8] Joshi, K. (1991). A model of users' perspective on change: The case of information systems technology implementation. *MIS Quarterly*, 15(2), 229-242.
- [9] Kim, H. W. (2010). The effects of switching costs on user resistance to enterprise systems implementation. *IEEE Transactions on Engineering Management*, 58(3), 471-482.
- [10] Kim, H. W., & Kankanhalli, A. (2009). Investigating user resistance to information systems implementation: A status quo bias perspective. *MIS Quarterly*, 33(3), 567-582.
- [11] Klaus, T., & Blanton, J. E. (2010). User resistance determinants and the psychological contract in enterprise system implementations. *European Journal of Information Systems*, 19(6), 625-636.
- [12] Lapointe, L., & Rivard, S. (2005). A multilevel model of resistance to information technology implementation. *MIS Quarterly*, 29(3), 461-491.
- [13] Liu, J., & Mao, Y. (2019). Patient satisfaction with rural medical services: A cross-sectional survey in 11 Western Provinces in China. *International Journal of Environmental Research and Public Health*, 16(20), 1-15. doi:10.3390/ijerph16203968.
- [14] Liu, Y., Guo, J. J., & Zhao, J. (2013). The study of informatization construction in the development of hospital. *China Digital Medicine*, 8(07), 38-40+44. http://en.cnki.com.cn/Article_en/CJFDTotal-YISZ201307014.htm
- [15] Manzoor, F., Wei, L., Hussain, A., Asif, M., & Shah, S. I. A. (2019). Patient satisfaction with health care services; An application of physician's behavior as a moderator. *International Journal of Environmental Research and Public Health*, 16(18), 1-16. doi: 10.3390/ijerph16183318
- [16] Marakas, G. M., & Hornik, S. (1996). Passive resistance misuse: overt support and covert recalcitrance in IS implementation. *European Journal of Information Systems*, 5(3), 208-219.
- [17] Martinko, M. J., Zmud, R. W., & Henry, J. W. (1996). An attributional explanation of individual resistance to the introduction of information technologies in the workplace. *Behaviour & Information Technology*, 15(5), 313-330.
- [18] Orlikowski, W. J. (1993). CASE tools as organizational change: Investigating incremental and radical changes in systems development. *MIS Quarterly*, 17(3), 309-340.
- [19] Wu, X., Chen, Q., & Li, J. (2008). A model of IT resistance based on behavioral factors and its empirical study. *Journal of Xidian University (Social Science Edition)*, 18(5), 7-12. doi: 10.16348/j.cnki.cn61-1336/c.2008.05.015
- [20] Yin, R. K. (2017). *Case Study Research and Applications: Design and Methods*. SAGE Publications.

APPENDIX: Interview Outline

1、 Basic information of respondents

- (1) Age:
- (2) Gender:
- (3) Educational background:
- (4) Position in hospital:
- (5) Years of medical practice:

2、 Interview questions:

- (1) Do you feel bothered by the contract signing system after you really use it? If so, what are the specific manifestations of these problems? What are your specific actions in the face of these problems?
- (2) Do previous habits or experiences of using an information system affect the use of the new contract signing system? Do these impacts help you better use the new system or make it difficult for you to switch to the use of the new system?
- (3) Learning to use the new system requires a lot of time and effort to receive training and to adapt to the new environment or system. What is your attitude towards this situation? And what are your specific actions?
- (4) After using the new system, do you think the system has improved your work efficiency and quality? If not, what do you think led to this result? And what are your actions in the face of such a result?
- (5) From the original working mode (or using the original system) to using a new system, do you think the new system has helped your work or made you gain more?
- (6) Do you think the new contract signing system put into use is useless? Why do you have this idea? What are your specific actions in the face of this idea?
- (7) After the contract signing system is put into use, do the organizations (such as: Health and Family Planning Commission, software development company, hospitals, etc.) provide systematic and effective training? How do you rate these training?

- (8) Do organizations which has mentioned in question7 provide the necessary support and help when there are difficulties in using the new system? Is this enough to help you solve the problem in time?
- (9) Have you ever thought about why you want to use the contract signing system? Do you know what the purpose of the new system is? What is your opinion on this? What are your actions in the face of this situation?
- (10) What is your opinion or attitude towards the hospital's practice of forcing you to use the new system?
- (11) From the perspective of system function, what is your evaluation of the contract signing system?
- (12) In terms of system performance, what problems do you think affect your experience in using the contract signing system?
- (13) During the operation of the contract signing system, what problems do you think affect your feeling of using the system?
- (14) Do these difficulties make you reluctant to continue to use the system? Are these ideas strong?

Website Quality of Listed Companies: A Comparison between SMES and Large Firms

(Full Paper)

Mathupayas Thongmak*, Thammasat Business School, Thammasat University, Thailand,
mathupayas@tbs.tu.ac.th

Winai Nadee*, Thammasat Business School, Thammasat University, Thailand, winai@tbs.tu.ac.th

ABSTRACT

Websites are the main information source for investors, so the quality of companies' websites are vital. This study explores the website quality of listed companies in Thailand and draws a comparison between SMEs' and large firms' website quality. In total, concrete and overall objective measures of 271 listed companies (136 large firms from the SET market and 135 SMEs from the MAI market) are collected using a website evaluation tool called SEOptimer. Non-parametric statistics are employed for data analysis due to non-normality. Findings reveal the room for improving the website quality for both SMEs and large companies in each industry. SMEs significantly have lower website quality in terms of SEO, performance, social, security, and overall compared to large enterprises. This study presents the research opportunities to explore listed companies in other countries using other tools in the future and guides SMEs and large companies in Thailand to effectively improve their website quality from the reliable measures and practical suggestions.

Keywords: Website quality; website evaluation; SEOptimer; SMEs, large firms, Thailand.

*Corresponding author

INTRODUCTION

A website is a platform that is crucial for information and transaction (Yang, Shi, Wang, & Yan, 2014). A business website represents an integral part of e-business strategy and elicits the impressions and reactions of stakeholders (Canziani & Welsh, 2016; Galati *et al.*, 2016; Pirchegger & Wagenhofer, 1999). It is also a market space that enables a company to conduct business, reach global audiences, and interact with its customers in innovative ways (Rasheed *et al.*, 2018; Sharma & Lijuan, 2015). Customers depend on the Internet to find product information and conduct a purchase electronically (Sharma & Lijuan, 2015). From their perspective, the successful website should meet their expectations and give them positive experiences, so companies should develop high-quality websites that provide better online experiences (Hasanov & Khalid, 2015; Sharma & Lijuan, 2015).

Website design determines the ability of a company to reap the benefits of the Internet. Poor website design such as usability could lead to poor corporate image and reputation (Canziani & Welsh, 2016; Sharma & Lijuan, 2015). Website quality drives online business, effective communications to customers, and Word-of-Mouth (WOM) and could lead to profitability from the retained customers (Biswas, Nusari, & Ghosh, 2019; Fatahi & Moosavi Bideleh, 2018; Yang *et al.*, 2014). The information richness, online service, easy to use, interactivity, web traffic, reliability reflect a website's effectiveness and are crucial for customers' purchase decisions (Sharma & Lijuan, 2015; Yang *et al.*, 2014). A website needs to possess these quality attributes since website quality is a measure for website design success (Galati *et al.*, 2016; Sharma & Lijuan, 2015). Consequently, website quality evaluation becomes more and more important (Yang *et al.*, 2014).

Websites have been evolved from reading information (Web 1.0) to executing mode/ semantic web (Web 3.0), making them complex nowadays (Rasheed *et al.*, 2018). However, without a significant programming ability, these websites are difficult to observe, leading to the need for an evaluation tool for more sophisticated websites (Canziani & Welsh, 2016). The SEOptimer is a Search Engine Optimization (SEO) audit tool, which can be used for detailed website analysis. It evaluates website quality using 100 website data points and provides clear and actionable recommendations for website owners and website designers to improve a website's effectiveness. The tool can be also accessed via the website. Not only a website's performance that can be explored, but also SEO, usability, social, security, and overall (Rasheed *et al.*, 2018; SEOptimer, 2020).

Small and Medium-sized Enterprises (SMEs) face various problems and challenges in the aspects related to financing, technology, managerial capabilities, skill development and productivity, international market access, and regulatory burdens compared to large firms (Wasiuzzaman, 2019). Due to these constraints, there were significant differences in website adoption rates between large firms and SMEs in the past and there still have SMEs in some sectors reluctant to adopt new technologies at the present (Galati *et al.*, 2016; Gemino, MacKay, & Reich, 2006). However, if they are willing to adopt new technologies,

they will be more flexible with a higher capacity to adapt and could be successful as same as large firms (Gemino *et al.*, 2006). The study of Heiens, Pleshko, and Ahmed (2019) believes that customer satisfaction levels will be higher for SMEs than for large enterprises. SMEs could try to be active and offer actual and meaningful information through fast supports on their websites (Constantinescu-Dobra, 2012). Moreover, newly established (small) companies such as startups connect to their customers using websites and social media platforms to provide the status quo of their campaigns and to fetch funding)Kaur & Gera, 2017(. Additional websites could enhance startups' communication with stakeholders and could help them to extend their potential reputation and signal their quality. A homepage additional to the project page on the crowdfunding platform significantly increases the success of their projects (Beier & Wagner, 2015).

Although website quality evaluation has been studied in the literature, many of these studies are conducted using subjective measures, which are generally assessed based on the perception of end-users (Biswas *et al.*, 2019; Canziani & Welsh, 2016; Sastika, Suryawardani, & Hanifa, 2016; Sharma & Lijuan, 2015). An objectivity quality evaluation system is thus required to decrease the subjectivity and biases in human judgment in website quality assessment (Canziani & Welsh, 2016; Galati *et al.*, 2016). The study of Rasheed *et al.* (2018) suggests future research to evaluate the performance of websites in different domains using open source tools to investigate new important signals. The study of Yang *et al.* (2014) indicates that there is still much room to improve the website quality. The study of (Canziani & Welsh, 2016) supports the use of automated website evaluation tools to reduce the degree of raters' errors in website evaluation. Using automated tools such as Website Grader, SEOptimer, and Qualidator to evaluate websites could reveal the points to be improved and help website designers to enhance their websites to reach international standards (Khandare, Gawade, & Turkar, 2017). Scores from these website quality evaluation tools are also advantageous for website owners in terms of comparing their websites to industry standards and competitor websites (Canziani & Welsh, 2016).

Therefore, this paper tries to fill the research gap and answer the following research questions using an automated tool (SEOptimer) to evaluate website quality: (a) Do listed companies in different sizes (SMEs vs. large enterprises) perform differently in designing high-quality websites?; and (b) How are the website quality of the listed companies in the Stock Exchange of Thailand (SET) and Market for Alternative Investment (MAI) in each industry? According to The Stock Exchange of Thailand (n.d.), SET is a stock market for large companies, while MAI is a source of funding for SMEs.

LITERATURE REVIEW

Tarigan (2009) assessed user satisfaction and explore the website quality from the e-library users of the Stock Exchange of Thailand using WEBQUAL theory. End-users supported some degree of the positive relationship between WEBQUAL dimensions and their satisfaction. Constantinescu-Dobra (2012) examined websites of Romanian companies (SMEs and large companies) from top-hundred software, hardware, and IT distributor companies in terms of content, in-time communication tools, navigability, and styles in correlation with their marketing outcomes and size. Findings indicated a strong correlation between website content and companies' turnover, profits, and the number of employees and a positive correlation between interactivity and turnover. Galati *et al.* (2016) evaluated website quality of Italian wineries using the Web Assessment Index (WAI), compared e-commerce and e-marketing websites and verified the associations between website quality and business revenues and the characteristics of managers. The results pointed out that e-commerce websites had higher website quality than e-marketing websites. Business revenues and the educational level of managers positively affected companies' website quality. Canziani and Welsh (2016) reviewed websites of SMEs in winery tourism using automated website evaluation. An automated evaluation scoring system could discriminate best practice websites and other websites of wineries in the USA and North Carolina. Gawade, Raikar, and Chopade (2017) applied a set of automated tools that were Qualidator tool, Website Grader, and SEOptimer to evaluate agricultural sites, particularly their usability. Fatahi and Moosavi Bideleh (2018) examined the influence of financial service providers' website quality on customer responses among brokerages using the Stimulus Organism Response (SOR) paradigm. Findings showed that website quality determined customer responses. It significantly directly impacted customer perceived value and corporate reputation, which significantly increased customers' purchase intention and WOM. Rasheed *et al.* (2018) compared the website performance of five foreign and local universities using two SEO tools: Nibbler and SEOptimer, to reveal the strengths and weaknesses of these websites.

HYPOTHESIS DEVELOPMENT

Website quality and its consequences

Websites are one of the online media campaigns, which play a crucial role in the business world (Sastika *et al.*, 2016). A website with well website design, usability, and SEO ensures customer success in looking for a company's information, goods, or services online (Rathi & Given, 2011). The perception of customers about website quality depends on website features that meet their needs such as appearance, navigation, well-organized and well-managed content display. Multiple dimensions of website quality are security, enjoyment, information quality, ease of use, and service quality. Website design is an important determinant to achieve website features and quality of services (Hasanov & Khalid, 2015). Website quality consists of both technical and service components, which are information, system, and service qualities (Chen, Huang, & Davison, 2017). Website quality dimensions consist of content, design, organization, and user-friendly (Hasanov & Khalid, 2015).

E-commerce website quality in terms of brand awareness, visitors scale, user experience, website speed, and interactivity generates profitability in terms of revenue and profit (Yang *et al.*, 2014). Website quality determines customers' purchase decisions (Biswas *et al.*, 2019; Yang *et al.*, 2014). Website quality (visual appeal, security, download delay, and navigability) significantly positively affects a customer's perceived product quality, which subsequently affects his/ her intention to purchase the product (Wells, Valacich, & Hess, 2011). Website quality (system quality, information quality, and service quality) significantly enhances customers' perceived value and corporate reputation, which have a positive effect on purchase intention (Fatahi & Moosavi Bideleh, 2018). Consumers' perception of website quality (usability and information quality) significantly influences their online shopping intention (Jones & Kim, 2010). Website quality in terms of website design, fulfillment/ reliability, customer service, and security/ privacy significantly indirectly impacts customers' purchase intention (Kim & Lennon, 2013).

Website quality significantly increases customer satisfaction that later significantly drives their purchase intention (Hasanov & Khalid, 2015). Website quality in terms of web layout, web information, customer service, fulfillment, and privacy are proposed to positively influence e-satisfaction (Ahmad, Rahman, & Khan, 2017). Usability, information quality, and service interaction quality have an impact on end-user satisfaction (Tarigan, 2009). Website design, service quality, information quality, ease of use, and process management are dimensions influencing consumer satisfaction (Yang *et al.*, 2014). In the Destination Marketing Organization (DMO) websites, website design quality (functional, emotional, symbolic dimensions) significantly positively related to relationship satisfaction, which significantly increases tourism customer e-loyalty (Tsai, 2017). Website service quality significantly improves the confirmation of customer expectations and in turn their satisfaction towards online shopping (Biswas *et al.*, 2019). The service quality of e-commerce websites significantly impacts user satisfaction (Sharma & Lijuan, 2015). Website quality directly affects customer loyalty (Sastika *et al.*, 2016). Information quality, system quality, and service quality of a seller's website are significantly positively related to the cognitive and structural capital between buyers and sellers, which later directly and indirectly reshape buyers' loyalty to sellers (Chen *et al.*, 2017).

SMEs and Large Companies

Many large and small businesses utilize websites as media to promote their products or services (Sastika *et al.*, 2016). Therefore, website design becomes a mandatory criterion for those who come into play. However, SMEs tend to have higher learning curves and longer implementation timeframes due to their restricted time and resources (Canziani & Welsh, 2016). Changes in the banking system since the financial crisis in 2008 and SMEs' characteristics make SMEs difficult to gain bank financing, so they are hard to scale up their production, adopt new technologies, create product/ service innovation, and increase profitability (Spithoven, Vanhaverbeke, & Roijackers, 2013; Wasiuzzaman, 2019). Business revenue significantly positively affect its website quality, which positively associates with business success. In the winery industry, companies with the lowest revenues are less likely to effectively adopt web marketing strategies (Galati *et al.*, 2016). A bigger company could afford to manage itself, conduct marketing activities online, and has more achievements than smaller firms (Constantinescu-Dobra, 2012). There are several opportunities and concerns relating to company size (SMEs vs. large companies) such as lower upfront investment, business continuity, mobility, scalability, performance, perceived insecurity of cloud and deployment speed (Johansson, Alajbegovic, Alexopoulos, & Desalermos, 2014). SMEs differ from large firms in terms of financial and staffing resources, which impede their e-business strategies such as developing a good website and pushing it to be listed in the top search engine results (Rathi & Given, 2011). In the case of Austrian companies, the website quality scores significantly increase when the company sizes expand (Pirchegger & Wagenhofer, 1999). In the study of (Constantinescu-Dobra, 2012), IT SMEs (hardware, software, distributors) have fewer website quality scores in terms of content, handling, interactive, and layout compared to large companies. Based on these findings, the following hypotheses are explored.

Hypotheses:

- H1: There is a difference in the website quality score (SEO) of SMEs and large firms.*
- H2: There is a difference in the website quality score (Usability) of SMEs and large firms.*
- H3: There is a difference in the website quality score (Performance) of SMEs and large firms.*
- H4: There is a difference in the website quality score (Social) of SMEs and large firms.*
- H5: There is a difference in the website quality score (Security) of SMEs and large firms.*
- H6: There is a difference in the website quality score (Overall) of SMEs and large firms.*

RESEARCH METHOD

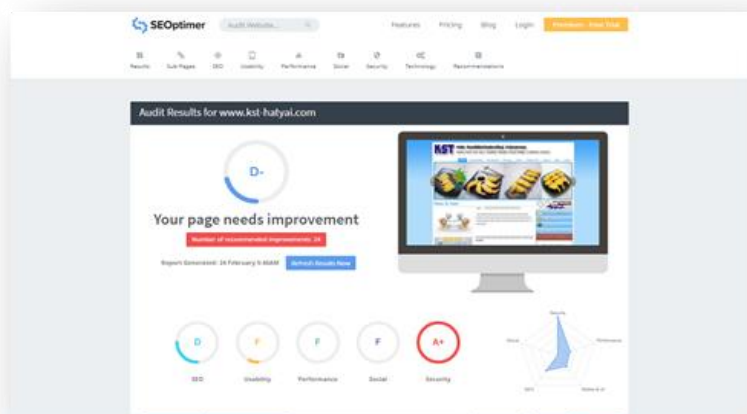

Figure 1. The result of a website's quality evaluation from SEOptimer.

Table 1. The conversion of grade to number

Grade	Score	Grade	Score	Grade	Score
A+	4.3	C+	2.3	E+	0.3
A	4	C	2	E	0
A-	3.7	C-	-1.7	E-	-0.3
B+	3.3	D+	1.3	F+	-0.7
B	3	D	1	F	-1
B-	2.7	D-	0.7	F-	-1.3

This work was a sub-project of the WEB ANALYZE SET project. This study collected data from listed companies in SET and MAI. According to The Stock Exchange of Thailand (n.d.), large companies in SET had more than 300 million baht in paid-up capital after Initial Public Offering (IPO), while SMEs in MAI had over 20 million baht in paid-up capital after IPO. A free automated website rating, SEOptimer, was applied to assess the website quality of each company. An automated website evaluation tool was believed to be a cost-effective and viable tool to complement the absence of objectivity and reliable raters and reduce the need for expert evaluators (Canziani & Welsh, 2016). The SEOptimer was available online (<https://www.seoptimizer.com/>). It evaluated various specifications of a website such as performance, mobile or User Interface (UI), social, and page analysis and gave clear recommendations to improve the website (Khandare *et al.*, 2017). The web crawler of SEOptimer accessed each homepage and sub-pages after a user inputted a company's URL and showed grades from A+ to F- regarding overall, SEO, usability, performance, social, and security respectively, as shown in Figure 1. Some companies' websites could not be evaluated since they had no content or had security mechanisms to reject SEOptimer's crawlers. These websites were removed from the analysis to prevent inaccurate results. This study employed quota sampling. There were companies in the SET market more than the MAI market. Hence, for the comparison purpose, all verified companies in the MAI market were included, whereas the highest-value companies in each group were selected.

DATA ANALYSES

As shown in Table 1, a specific number, adapting from the grade conversion of Berkeley (2020), was later assigned to all grades. The independent-samples t-test was planned to be used to test hypotheses in the first place. However, according to the Shapiro-Wilks test of normality, almost all variables in this study were not normally distributed. Also, Levene's Test of Equality of Variances indicated that the assumption of homogeneity of variances of website quality score (security) was broken. Two assumptions were violated, so a non-parametric test, Mann-Whitney U Test, was applied to test hypotheses instead of the independent samples t-test.

RESULTS

There were 271 listed companies (136 large companies from the SET market and 135 small and medium-sized enterprises from the MAI market) from 8 industries which were Agro & Food Industry (AGRO), Consumer Products (CONSUMP), Financials (FINCIAL), Industrial (INDUS), Property & Construction (PROPCON), Resources (RESOURC), Services (SERVICE), and Technology (TECH). The average total stocks of large companies were 14,339,705 with the average value of SMEs were 345,893.15 billion baht, whereas the average total stocks of 3,628,231 with the average value of 5,099.36 billion baht. The industry with the highest average value in SET was financials and the industry with the highest average value in

MAI was agro and food. Figure 2 to Figure 7 shows the median value of website quality scores in each aspect for companies in each industry. Higher median values of website qualities in each industry are presented with black outlines.

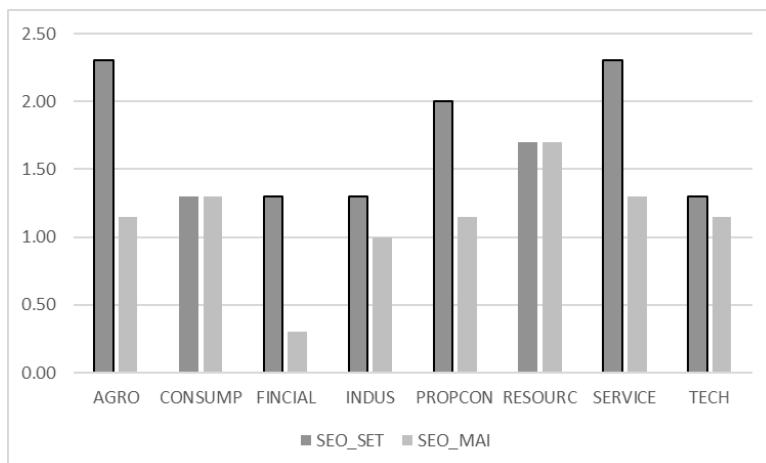

Figure 2. A chart showing median values of website qualities (SEO) of listed companies in SET and MAI

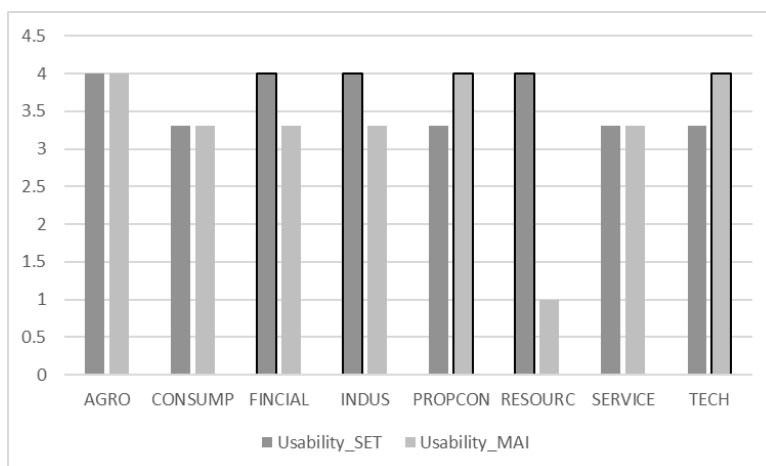

Figure 3. A chart showing median values of website qualities (Usability) of listed companies in SET and MAI

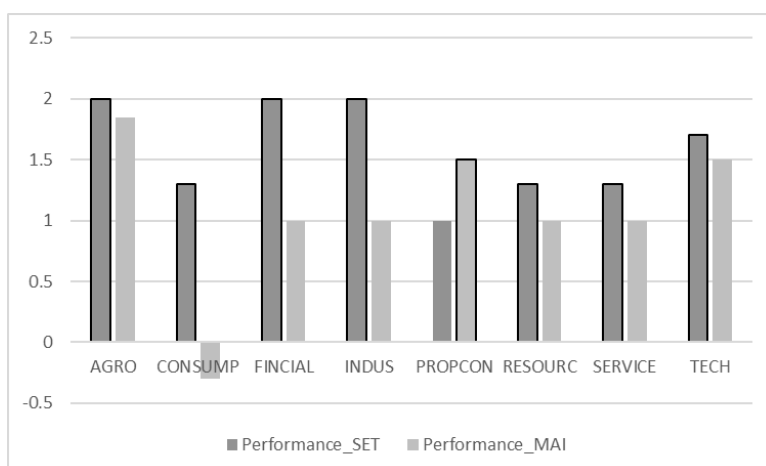

Figure 4. A chart showing median values of website qualities (Performance) of listed companies in SET and MAI

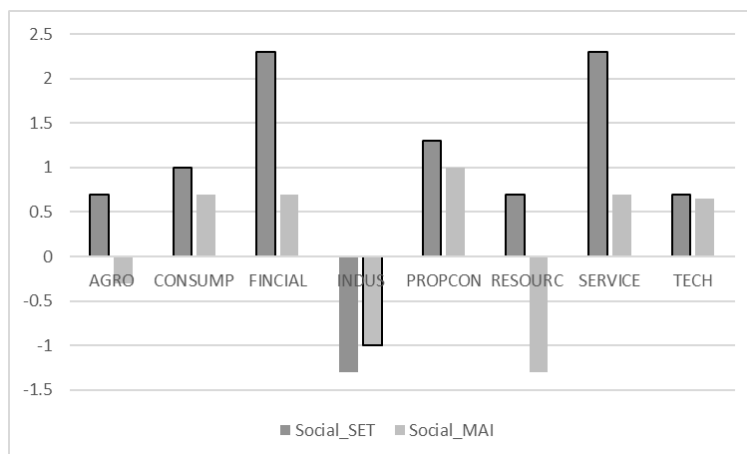

Figure 5. A chart showing median values of website qualities (Social) of listed companies in SET and MAI

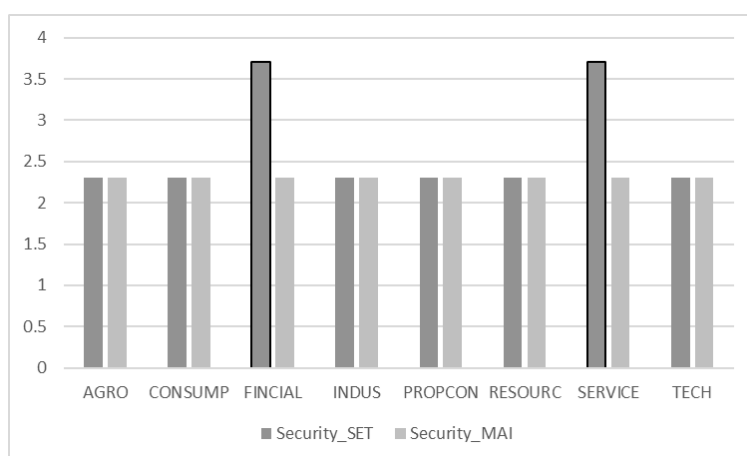

Figure 6. A chart showing median values of website qualities (Security) of listed companies in SET and MAI

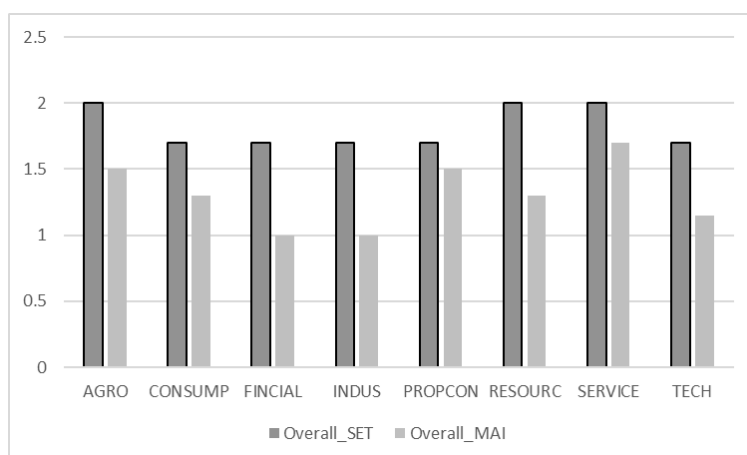

Figure 7. A chart showing median values of website qualities (Overall) of listed companies in SET and MAI

A Mann-Whitney U test revealed that there was a significant difference ($U = 6600.0, p = 0.000$) between the website quality (SEO) of large firms compared to SMEs. The median of large firms' website quality (SEO) was 1.7 compared to 1.0 for small and medium-sized companies. The median of website quality (Usability) in large firms and SMEs were 4.0 and 3.3. The distribution in two groups did not differ significantly ($U = 8146.5, p = 0.100$). A Mann-Whitney test also showed that the website quality (Performance) was greater for large companies ($Mdn = 1.7$) than for SMEs ($Mdn = 1.0$), $U = 7642.0, p = 0.017$. A Mann-Whitney test indicated that there was a statistically significant difference between the website quality (Social) of large firms ($Mdn = 0.7$) and SMEs ($Mdn = 0.7$), $U = 7283.0, p = 0.003$. A Mann-Whitney test pointed out that website quality (Security) was greater for large companies ($Mdn = 2.3$) than for SMEs ($Mdn = 2.3$), $U = 7286.5, p = 0.001$. Large companies also had the higher mean ranks in both website quality (Social) and website quality (Security) compared to SMEs, which could be considered as having a higher website quality in terms of social and security. For the overall website quality, website quality (Overall) scores in large companies ($Mdn = 1.7$) were statistically significantly higher than small and medium-sized companies

($Mdn = 1.3$), $U = 6075.0$, $p = .000$. Hence, there was enough evidence to reject null hypotheses of $H1$, $H3$, $H4$, $H5$, and $H6$ respectively (p -value < 0.05).

DISCUSSION AND IMPLICATIONS

Findings conform to the proposed hypotheses and their supports in the HYPOTHESIS DEVELOPMENT section, revealing the room for improvement in the website quality for both SMEs and large enterprises. This study presents the research opportunities for academics from using automated evaluation tools and objective measures instead of subjective measures, which possibly generate biases from human raters. Human rater bias could impact decisions about website quality (Canziani & Welsh, 2016). Objective measures from standard tools not only create reliable scores and sound suggestions but also help in the comparisons between a company's website quality and competitors or between a company's website quality and the industry benchmark. Besides, an online website quality evaluation tool helps to decrease programming efforts due to web evolution from static medium to semantic medium (Rasheed *et al.*, 2018) and supports companies with limited resources e.g. SMEs in website quality evaluation. Using automated evaluation methods are effective and are also suggested to be applied in various business sectors (Canziani & Welsh, 2016).

The findings could be used for the website management practices of listed companies, both SMEs and large enterprises, which are believed to have moderate resources for enhancing their websites. In the big picture, although SMEs have more agility than large firms, large companies have better website qualities than SMEs in almost all aspects, except usability in PROPCON & TECH, performance in PROPCON, and social in INDUS. However, because both SMEs and large companies are choices for stock market investors, SMEs have to enhance their website qualities for competitiveness. According to SEOptimer (2020), SMEs should improve their SEO by 1) adding a title tag with 10 – 70 characters and a meta description tag in the page heading, 2) using header tags with consistency keywords and adding more content particularly images with ALT attributes in the body content, 3) managing number of backlinks, on-page links, and broken links and using human/ search engine readable URLs, 4) avoiding no-index tag and no-index header, and 5) creating a robots.txt file to provide instructions for search engines and XML sitemaps and using analytic tools and schema.org (a structured data markup). To improve their performance, SMEs should 1) optimize their webpage speed, 2) decrease their page's file size to be around 5 MB per page, 3) remove unnecessary files to be downloaded from web servers or combine files like styles and scripts where possible, 4) beware of JavaScript errors, 5) enable GZIP compression, 6) format and compress images, 7) minify JavaScript and CSS files, 8) remove deprecated HTML tags, and 9) avoid inline style coding practices in HTML code.

To improve the social aspect, SMEs should 1) link their websites with their Facebook pages, Twitter, Instagram, YouTube, and LinkedIn, 2) add Facebook Open Graph tags and Twitter Cards, and 3) use Facebook Pixel to track users. For security, SMEs should 1) enable SSL, 2) redirect their page to the HTTPS version, 3) prevent malware attacks, and 4) remove email addresses in plain text on webpages. Although the usability of SMEs' websites is not significantly lower than large companies' websites. They can improve their webpages' usability by 1) optimizing users' experiences (page renders) on different devices such as PCs, mobile phones, and tablets, 2) utilizing mobile viewpoints to ensure page content sizes for different devices, 3) removing Flash content and iFrames, 4) specifying a favicon, 5) using proper text size on their pages for all devices, and 6) expanding Tab targets to be larger for better user experiences.

Comparing between SMEs and large firms, almost all SMEs should actively improve their website qualities. Breaking into the industry level of large companies, the Agro & Food Industry (ARGO) focuses on SEO, usability, performance, and overall. Financials (FINCIAL) are remarkable in terms of usability, performance, social, and security, whereas Industrial (INDUS) is outstanding in usability and performance. Resources (RESOURC) perform well in usability and overall, while Services (SERVICE) are excellent in SEO, social, security, and overall. Large firms in Consumer Products (CONSUMP), Property & Construction (PROPCON), and Technology (TECH) still have more rooms to improve their website qualities using the above suggestions. Considering each website quality, all large companies give an important on website usability. Large firms in some sectors i.e., financials and services are highly concerned about security. However, large companies in every industry still have more rooms to enhance their SEO, performance, overall, and particularly social qualities.

For SMEs, the Agro & Food Industry (AGRO) is good in usability, performance, and security. SMEs in Consumer Products (CONSUMP), Financials (FINCIAL), and Industrial (INDUS) perform well in security. Property & Construction (PROPCON) is outstanding in usability, social, and security. Resources (RESOURC) are distinguished in SEO and security, whereas Services (SERVICE) are notable in security and overall. Technology (TECH) is marked in usability and security. Considering each quality aspect, SMEs in almost all sector except RESOURC give an importance on usability and security. Nevertheless, SMEs in every industry should improve their SEO, performance, overall, and especially social qualities.

CONCLUSION AND RECOMMENDATIONS

Investors search for company-related information from the company websites. The purposes of this paper are thus to explore the website quality of listed companies both SMEs and large enterprises in Thailand using a website evaluation tool, SEOptimeter and compare the website quality between SMEs and large firms. The findings suggest the improvement of website quality, particularly SMEs, in various industries. Using an automated tool in the context of listed company websites show the usefulness of website evaluation tool to technically assess website quality in multiple aspects (SEO, usability, performance, social, security, and overall) and to give practical guidelines for website owners and developers.

LIMITATIONS AND FUTURE RESEARCH

This study primarily focuses on assessing websites, especially in the technical aspects, so the study does not reflect the users' or investors' perceptions of website quality. There are some restrictions on reported information from the free services of the SEOptimizer. Future work, therefore, could additionally explore more results from the paid services. Furthermore, this paper use samples from listed companies in Thailand only. Future research should investigate the website quality of companies in other countries and deeply examine in some company types such as export companies and some industries such as tourism that use websites as the main channel to communicate globally. Future research should also develop local and global benchmarks for each industry. There are various automated website evaluation tools available, for instance, Website Grader and Qualidator (Gawade *et al.*, 2017; Khandare *et al.*, 2017). Future research should conduct the comparative analysis of website quality for companies in each industry using these tools to suggest the best tool to be applied.

REFERENCES

- [1] Ahmad, A., Rahman, O., & Khan, M. N. (2017). Exploring the role of website quality and hedonism in the formation of e-satisfaction and e-loyalty. *Journal of Research in Interactive Marketing*, 11(3), 246-267
- [2] Beier, M., & Wagner, K. (2015). *Crowdfunding success: a perspective from social media and e-commerce*. Paper presented at the International Conference on Information Systems (ICIS), Fort Worth, Texas, USA.
- [3] Berkeley, U. (2020). GPA Calculator. Retrieved from <https://reslife.berkeley.edu/gpa-calculator>
- [4] Biswas, K. M., Nusari, M., & Ghosh, A. (2019). The influence of website service quality on customer satisfaction towards online shopping: The mediating role of confirmation of expectation. *International Journal of Management Science and Business Administration*, 5(6), 7-14.
- [5] Canziani, B. F., & Welsh, D. H. (2016). Website quality for SME wineries: Measurement insights. *Journal of Hospitality and Tourism Technology*, 7(3), 266-280
- [6] Chen, X., Huang, Q., & Davison, R. M. (2017). The role of website quality and social capital in building buyers' loyalty. *International Journal of Information Management*, 37(1), 1563-1574.
- [7] Constantinescu-Dobra, A. (2012). Is the website marketing strategy correlated with the companies outcomes? Evidence from Romanian it industry. *Annals of the University of Oradea, Economic Science Series*, 21(1), 1134-1140.
- [8] Fatahi, Y., & Moosavi Bideleh, S. S. (2018). Investigating the effect of website quality on trader's responses in e-financial services of stock brokerage. *International Journal of Web Research*, 1(2), 27-33.
- [9] Galati, A., Crescimanno, M., Tinervia, S., & Siggia, D. (2016). Website quality and internal business factors. *International Journal of Wine Business Research*, 28(4), 308-326.
- [10] Gawade, S., Raikar, K., & Chopade, S. (2017). *Usability evaluation of agricultural websites*. Paper presented at the 4th International Conference on "Computing for Sustainable Global Development" (INDIACom-2017), Bharati Vidyapeeth's Institute of Computer Applications and Management (BVICAM), New Delhi (INDIA).
- [11] Gemino, A., MacKay, N., & Reich, B. H. (2006). Executive decisions about website adoption in small and medium-sized enterprises. *Journal of Information Technology Management*, 17(1), 34-49.
- [12] Hasanov, J., & Khalid, H. (2015). The impact of website quality on online purchase intention of organic food in Malaysia: A WebQual model approach. *Procedia Computer Science*, 72(6), 382-389.
- [13] Heiens, R. A., Pleshko, L. P., & Ahmed, A. A. (2019). A comparison of the relationship marketing outcomes of SMEs vs large enterprises in the Kuwait fast food industry. *British Food Journal*, 121(10), 2442-2453.
- [14] Johansson, B., Alajbegovic, A., Alexopoulos, V., & Desalermos, A. (2014). *Cloud ERP adoption opportunities and concerns: a comparison between SMES and large companies*. Paper presented at the Pre-ECIS 2014 Workshop "IT Operations Management"(ITOM2014).
- [15] Jones, C., & Kim, S. (2010). Influences of retail brand trust, off-line patronage, clothing involvement and website quality on online apparel shopping intention. *International Journal of Consumer Studies*, 34(6), 627-637.
- [16] Kaur, H., & Gera, J. (2017). Effect of social media connectivity on success of crowdfunding campaigns. *Procedia Computer Science*, 122, 767-774.
- [17] Khandare, S. S., Gawade, S., & Turkar, V. (2017). *Survey on website evaluation tools*. Paper presented at the 2017 International Conference on Recent Innovations in Signal Processing and Embedded Systems (RISE).
- [18] Kim, J., & Lennon, S. J. (2013). Effects of reputation and website quality on online consumers' emotion, perceived risk and purchase intention. *Journal of Research in Interactive Marketing*, 7(1), 33-56.
- [19] Pirchegger, B., & Wagenhofer, A. (1999). Financial information on the internet: a survey of the homepages of Austrian companies. *European Accounting Review*, 8(2), 383-395.
- [20] Rasheed, K., Noman, M., Imran, M., Iqbal, M., Khan, Z. M., & Abid, M. M. (2018). Performance comparison among local and foreign universities websites using seo tools. *ICTACT Journal on Soft Computing*, 8(2), 1597-1610.
- [21] Rathi, D., & Given, L. M. (2011). Designing digital marketplaces for competitive advantage. In *E-Business issues, challenges and opportunities for SMEs: Driving competitiveness* (pp. 1-19): IGI Global.
- [22] Sastika, W., Suryawardani, B., & Hanifa, F. (2016). *Analysis of website quality, brand awareness on trust and its impact on customer loyalty*. Paper presented at the 2016 Global Conference on Business, Management and Entrepreneurship.
- [23] SEOptimer. (2020). SEO Audit & Reporting Tool. Retrieved from <https://www.seoptimizer.com/>

- [24] Sharma, G., & Lijuan, W. (2015). The effects of online service quality of e-commerce Websites on user satisfaction. *The Electronic Library*, 33(3), 468-485.
- [25] Spithoven, A., Vanhaverbeke, W., & Roijakkers, N. (2013). Open innovation practices in SMEs and large enterprises. *Small Business Economics*, 41(3), 537-562.
- [26] Tarigan, J. (2009). User satisfaction using Webqual instrument: A research on stock exchange of Thailand (SET). *Jurnal Akuntansi Dan Keuangan*, 10(1), 24-47.
- [27] The Stock Exchange of Thailand. (n.d.). Listing. Retrieved from https://www.set.or.th/en/faqs/listing_p1.html
- [28] Tsai, S.-P. (2017). E-loyalty driven by website quality: The case of destination marketing organization websites. *Journal of Organizational Computing and Electronic Commerce*, 27(3), 262-279.
- [29] Wasiuzzaman, S. (2019). Resource sharing in interfirm alliances between SMEs and large firms and SME access to finance: A study of Malaysian SMEs. *Management Research Review*, 42(12), 1375-1399
- [30] Wells, J. D., Valacich, J. S., & Hess, T. J. (2011). What signal are you sending? How website quality influences perceptions of product quality and purchase intentions. *MIS Quarterly*, 35(2), 373-396.
- [31] Yang, Z., Shi, Y., Wang, B., & Yan, H. (2014). Website quality and profitability evaluation in ecommerce firms using two-stage DEA model. *Procedia Computer Science*, 30, 4-13.

What Factors Influence Customers' Purchase Intentions in Travel-Related Social Commerce?

(Full Paper)

Jin Guo, Northumbria University, UK, jinguo@northumbria.ac.uk

Shan Shan*, Northumbria University, UK, Shan.Shan@northumbria.ac.uk

Yulei, Li, Durham University UK, Yulei.li@durham.ac.uk

ABSTRACT

Social commerce significantly impacts the tourism and hospitality industry. Nonetheless, further empirical research investigating the factors that impact the purchase intentions of those who engage with travel-related social commerce. Combining the Uses and Gratification Theory (UGT) and TAM, the present study will investigate the relationships between purchases intentions and the following factors: perceived usefulness, perceived ease-of-use, entertainment, interaction and information seeking. During the research, four different models will be compared. The Ridge Model will be used to explain the effects of the aforementioned factors. The findings indicate that customers' social commerce purchase intentions are positively impacted by all five factors.

Keywords: Social media, uses and gratifications theory, social commerce, TAM, purchase intention.

*Corresponding author

INTRODUCTION

E-commerce has developed rapidly in recent times thanks to advancements in information and communication technologies, as well as the creation of Web2.0 technologies. The rapidly-increasing popularity of social technologies and social media platforms has been a key factor in pushing these advancements (Liang & Turban, 2011)). People are choosing to spend more time on the internet and interacting with others on social platforms (online communities).

The hospitality and tourism sectors have been significantly affected by consumer-generated media, social media outlets (including social networking sites, virtual communities, weblogs, Apps and photo/video sharing platforms) and websites dedicated to travel-related reviews. Social commerce users can rate and review their travel-related experiences online. Moreover, they can obtain and share information about their travel experience, leave comments, express opinions and make recommendations about airlines, restaurants and hotels (Nusair *et al.*, 2013). Such users find travel-related online reviews to be highly trustworthy. Park and Yoon (2009) explain that users place significant trust in travel-related online reviews.

Social media regulates social commerce (Hajli, 2015). As the popularity of social media continues to grow, people are turning to social commerce for more and more reasons, including to book tickets, seek travel information and to interact with other users. Social commerce marketing is largely reliant upon social media and its capacity to facilitate the exchange of information and opinions about different services and products (Cha, 2009; Hajli, 2013)). Through social commerce, individuals can seek specific product and service-related information (Liang *et al.*, 2011)). Moreover, they can learn about new, interesting products or services (Phang, Zhang, & Sutanto, 2013)), recommend rate products, share information and opinions about products or companies, and make transactions (Hu *et al.*, 2016; Olbrich & Holsing, 2011). This ultimately increases their usage intentions (Kim, 2013; Liang *et al.*, 2011).

Therefore, more and more researchers have been investigating the factors that influence consumers' purchase intentions in social commerce over the last few years (e.g., Hajli, 2015; Hu, Chen, & Davison, 2019; Um, 2019; Yahia, Al-Neama, & Kerbache, 2018). Previous studies concentrated predominantly on the factors that impact the purchase decisions and intentions of online consumers (Kwahk & Kim, 2017), as well as their urges to impulsively purchasing restaurant products and services (Chung, Song, & Lee, 2017), and their loyalty to travel-related online social networks (Nusair *et al.*, 2013). Some researchers, such as Tang *et al.* (2012) have explored the travel intentions of online consumers, whilst others have investigated their intentions to visit tourist destinations (Chen, Shang, & Li, 2014), and their intentions to remain loyal (Harrigan *et al.*, 2017). Recent research carried out by Ponte, Carvajal-Trujillo, and Escobar-Rodríguez (2015) has shown that travellers' online purchase intentions are positively impacted by perceived value and trust. Other factors found to influence online purchase intentions include perceived flow (Ali, 2016), consumer online reviews (Chen & Chang, 2018), and the quality of the website and available information (Tarkang *et al.*, 2020). Social commerce purchase intentions have evidently increased. Nonetheless, further research is still required in order to identify ways to effectively increase consumer participation in social commerce and to further understand the factors that drive consumers' social commerce purchase intentions.

At present, there are at least two significant research gaps that must be addressed. First of all, no studies have attempted to

investigate the relationship between social motives (such as entertainment, information seeking and social interactions) and purchase intentions in social commerce. By exploring these factors in more depth, managers will be able to make better decisions regarding the allocation of limited resources. Secondly, although several studies have found that consumer experience factors such as trust, perceived, website quality and perceived flow serve as the key factors driving consumers' purchase intentions on social commerce sites (Ponte *et al.*, 2015), the extent to which technology system experience factors (such as perceived ease-of-use and usefulness) influence purchase intentions in social commerce is unknown.

In the present research, the aforementioned research gaps will be addressed. The research thus focuses on exploring the factors influencing social media usage in travel-related social commerce (information seeking, entertainment, and social interaction). The extent to which technology-system experience factors (perceived ease-of-use and usefulness) influences users' purchase intentions in travel-related social commerce will also be investigated. To technology-related factors and three travel-related social-commerce usage motivations will be tested in the present study, as well as one behavioural intention. To test these relationships, a parsimonious conceptual model will be developed based on Technology Acceptance Model (Davis, 1989) and Uses and Gratification Theory (UGT) (Katz, Blumler, & Gurevitch, 1973).

Didi and LaRose (2006) explain that UGT can help researchers to understand the reasons for which people use social media, such as to seek information or for social interaction and entertainment purposes. UGT is based on the assumption that consumers actively engage with social media to fulfil specific needs and not to passively acquire information (Gao & Feng, 2016). Moreover, consumers actively engage with media to find any information that they require, to entertain themselves, and to uphold relationships with family members, friends, acquaintances and even strangers (Kim *et al.*, 2016; Lin & Liu, 2012). Users who can find accurate and reliable information from social media are more likely to use it for purposes of seeking information. Additionally, travellers who can successfully obtain information from knowledgeable social media providers are more likely to use it to seek information, to entertain themselves and to communicate with others. Collaboratively, these factors can enhance consumers' social commerce purchase behaviours and intentions.

The present research contributes to the understanding of purchase intentions in travel-related social media in three significant ways. Firstly, it will enhance understanding of the socio-psychological factors that drive consumer purchase intentions in social commerce by combining technology-system experience factors and social-media usage motivations in a research model. Secondly, it shows that technology-system experience factors have a stronger influence than social media usage motivation factors. Thirdly, the findings of the present study can help companies to develop their social commerce strategies by giving them a more profound understanding of consumer purchase behaviours.

THEORETICAL FRAMEWORK, HYPOTHESES, AND CONCEPTUAL MODEL

Social Commerce

No standard definition of social commerce exists in previous literature on the topic. However, most researchers highlight two key elements of it, namely: social activities and commercial activities. (Liang & Turban, 2011; Zhang & Benyoucef, 2016). Social commerce has been defined by Sturiale and Scuderi (2013) as the use of internet-based media to purchase and sell items, as well as to share and compare information about items sold in online marketplaces. However, a different definition is provided by Sharma and Crossler (2014), who state that social commerce is a type of online commerce developed from Web 2.0 which enables users to be interactive and communicate via blogs, wiki pages and self-created content. Furthermore, social commerce is also deemed to be a type of traditional e-commerce in which Social Networking Sites (SNSs) are used to encourage social interactions when buying and selling products/services online (Marsden & Chaney, 2012; Zhang & Benyoucef, 2016). On the other hand, Ngai, Tao, and Moon (2015) describe social commerce as the action of selling products via social media platforms (including Facebook and WeChat). Although many different definitions of social commerce have been put forward by researchers, the present research will employ Curty and Zhang (2011) definition that it is a type of e-commerce in which social media is used to facilitate social interactions and to enable users to make contributions to the online purchase experience by participating in a collaborative online environment.

In recent times, researchers have divided social commerce into two categories, namely social network sites designed with commercial features that enable users to advertise and make transactions, and conventional e-commerce websites like Amazon and eBay, which incorporate social networking tools which allow users to engage in social interactions (Pöyry, Parvinen, & Malmivaara, 2013; Zhang & Benyoucef, 2016). Most previous studies have referred to the former type of social commerce (Amblee & Bui, 2011; Ng, 2013). Amazon allows for social interactions by enabling users to leave online reviews and thus Amblee and Bui (2011) describe Amazon as being a practical form of social commerce. Another practical social commerce site is Groupon, a group buying website where users create groups to purchase products at discounted prices (Kim, 2013; Kim & Park, 2013; Wagner & Majchrzak, 2006). The Uses and Gratifications Theory will be employed in the present research since social interaction characteristics are prevalent in social commerce.

Uses and Gratifications Theory

UGT theory can be used to explore the factors that motivate individuals to use social media and the gratifications that people get from using social media. Moreover, the UGT assumes that people actively choose their media consumption in an attempt to satisfy their needs (Katz, 1974). It is regarded as an axiomatic theoretical approach since its principles can be applied to pretty

much all types of media-based communication, including both traditional media (such as newspapers) and interactive media (i.e., the Internet).

UGT has been employed in empirical studies by many different researchers (Ku, Chu, & Tseng, 2013; Lee & Ma, 2012; Park, Kee, & Valenzuela, 2009). It is a theoretical framework that can be used to develop hypotheses relating how factors such as information seeking and sharing, entertainment, and relationship maintenance influence social commerce and information-seeking behaviour. To be more precise, UGT has been described by Katz *et al.* (1973, p. 510) as a model upon which the social and psychological origins of needs are identified. This generates expectations of the mass media and other sources and can ultimately cause different media exposure patterns to emerge. This enables one's needs to be fulfilled but may also result in other (often unplanned) consequences. Moreover, Katz *et al.* (1973) also point out that, under the UGT, it is believed that media can fulfil individuals' needs and that gratifications can re-design individuals' needs. The UGT is highly applicable for use in research which explores interactive media or social media issues since it concentrates predominantly on the motives of media acceptance.

Different motivations for using social media have been identified in empirical studies that have used. Kaye (1998) found that entertainment, escape, social interactions, information-seeking, website preferences and passing time were the key factors motivating individuals to use the internet. On the other hand, Smock *et al.* (2011) found that entertainment, companionship, expressive information sharing, professional enhancement and social interactions were the key factors driving Facebook use. Sheldon (2008) also investigated Facebook usage motivations and found that age, gender and education played a significant role in motivating individuals to use the platform for entertainment, upholding relationships, interactions with virtual communities and for passing time. Five key factors motivating internet usage were identified by Papacharissi and Rubin (2000), namely interpersonal utility, information seeking, passing the time, entertainment and convenience. Moreover, Luo, Chea, and Chen (2011) research revealed that information-seeking, entertainment and interpersonal utility were positively related to behavioural usage. Lee and Ma (2012) found that social interactions, information seeking, status enhancement and previous social-media sharing experiences largely influenced users' intentions to share news items. Ten motivations for social media usage were also identified by Whiting and Williams (2013), namely: information seeking, social interaction, entertainment, relaxation, passing the time, communication, convenience, expressing opinions, sharing information and finding out information about other users.

Luo *et al.* (2011) explain that information seeking serves as a key motivating factor for internet usage. People turn to the internet to find out information about people, places and events (Luo *et al.*, 2011). Social media can be very helpful for those seeking information for making plans to travel since it allows users to access the most up-to-date information travel. Furthermore, people can simply enjoy themselves and have fun on social media, which enhances their purchase intentions. Social interaction has been defined by Hsu, Chang, and Chen (2012) as communication with family members, friends or even new individuals via social media (Sheldon, 2008). A number of individual needs (including the need to socialise and to entertain oneself) were found by Park *et al.* (2009) to be the key reasons for which college student engage in Facebook groups. Recent research has also found that social interactions encouraged individuals to seek travel-related information on social media (Chung, Han, & Koo, 2015). Thus, in brief, entertainment and information seeking are considered to be the key factors influencing social commerce behaviour and intentions to share information. The following hypotheses have been developed in accordance with the UGT (Katz *et al.*, 1973) and existing empirical evidence in the field of travel and tourism:

H1: Social commerce purchase intentions are positively impacted by information seeking.

H2: Social commerce purchase intentions are positively impacted by entertainment.

H3: Social commerce purchase intentions are positively impacted by travel-related social media interactions.

Technology Acceptance Model

Since social commerce has many technological characteristics, the present research employed the Technology Acceptance Model (TAM) in an attempt to explain the factors that influence travel consumers' purchasing behaviours. Several studies have used the TAM to explore aspects related to online shopping (Koufaris, 2002; Pavlou, 2003), the use of websites (Jiang, 2009; Moon & Kim, 2001; Porter & Donthu, 2006), acceptance of online banking platforms (Wang *et al.*, 2003) and SMS advertising (Dix *et al.*, 2017). Previous studies show that TAM can effectively explain several different technology-related behaviours (Luna-Nevarez & Torres, 2015). Moreover, Luna-Nevarez and Torres (2015) also used the TAM to explain the factors that influence consumers attitudes about advertisements on social networks. Therefore, the TAM is highly suited to explaining consumers' social commerce behaviours. By considering social commerce websites as technological tools, it can also be used to predict the antecedents of consumers' attitudes toward social commerce. There are two key constructs within the TAM, namely perceived usefulness and perceived ease-of-use.

Perceived Usefulness

Perceived usefulness has been defined by Davis (1989) as the extent to which an individual thinks that a website/tool/application will improve their work performance. Prior researchers have found, in several contexts, that perceived usefulness plays a significant role in developing positive attitudes toward technology. For example, Luna-Nevarez and Torres (2015) found that perceived usefulness positively impacts consumer attitudes towards advertisements on social

networks. Moreover, in relation to mobile-based advertising, Bauer *et al.* (2005) found that perceived usefulness tends to generate more favourable attitudes towards mobile advertising. There is significant evidence to suggest that individuals will more likely be accepting of a mobile advertising system if they perceive it to be useful (Bauer *et al.*, 2005; Merisavo *et al.*, 2007). What's more, some researchers have discovered that perceived usefulness positively impacts consumer attitudes towards e-commerce sites, and this positively impacts purchase intentions (Ahn, Ryu, & Han, 2004; Pavlou, 2003). Based on the information presented above, the hypothesis below has been developed:

H4: Social commerce purchase intentions are positively impacted by consumers' perceived usefulness.

Perceived ease-of-use

As previously stated, Davis (1989) defines perceived-ease-of-use as the extent to which an individual considers a technology to be effortless. If a new system is considered by consumers to be easy-to-use, it is more probable that they will accept it. In a social networking advertising context, Luna-Nevarez and Torres (2015) found that consumers' attitudes towards social network advertising were positively impacted by perceived ease-of-use. What's more, research has found that consumers' attitudes towards e-commerce websites, as well as their purchase intentions and loyalty intentions, were significantly influenced by the consumers' perceived ease-of-use (Ahn *et al.*, 2004; Koufaris, 2002; Pavlou, 2003). Thus, the following hypothesis is proposed in the present study:

H5: Consumers' perceived ease to use positively influence purchase intention in social commerce.

METHODOLOGY

Construct measurement and data collection

In the present research, a field study was carried out to investigate the factors influencing consumers social commerce purchase intentions. A questionnaire was used which contained 21 items categorised under six constructs. The items were taken from several existing sources and adapted to suit the specific purpose of the present research. The items are presented in Table 1. To begin with, the researchers conducted a pilot survey with 32 participants who had experience in using travel-related social media. The feedback from the pilot study was then used to modify the questionnaire and create a final questionnaire that would be used in the research. All items were measured using a 7-point Likert-scale, with number 1 indicating "strongly disagree" and number 7 indicating "strongly agree". To identify any inconsistencies in the answers, two screening questions were also employed.

To gather data, we sent an internet-based questionnaire to participants and invited them to partake (<https://www.wjx.cn>). A screening question was used to ensure that only people with previous experience using travel-related apps could take part. Participants were told that they would be given a summary of results produced automatically by the hosting website once they submit their completed survey. A total of 33 returned questionnaires were discarded because some contained incomplete responses and others contained the same response option for most of the question items. Thus, altogether, 359 valid responses were collected. Table 1 shows the demographic profile of the sample, of which 73.3% were female and 26.7% were male. Most respondents (68%) were aged between 21 and 30 years, and most (56.5%) had achieved tertiary Masters degrees. The sample was relatively homogeneous in terms of demographics and the constructs used in the research were similar to those used in previous studies. There are three additional items in the questionnaire, namely employment, gender and education. This is merely for descriptive purposes since ordinary data helps us to predict the determinates on social commerce. However, these variables were not subject to any further analysis.

Table 1: Descriptive statistics of variables

	Percentage (%)	Frequency
<i>Gender</i>		
Female	73.3	264
Male	26.7	96
<i>Age</i>		
20 or under	3.6	13
21-30	56.5	203
31-40	27.6	99
41-50	8.9	32
51-60	2.8	10
61or over	0.6	2
<i>Educational level achieved</i>		
High school or less	10	36
Undergraduate	36.5	131
Masters or over	53.5	192
<i>Occupational status</i>		
Full-time employee	57.1	205
Student	20.3	73

Self-employed	5.8	21
Freelancer	5.8	21
Others	10.9	39
<i>Income</i>		
Well below average	5	18
Below average	15	54
Just below average	18.4	66
Just above average	41.2	148
Above average	16.7	60
Well above average	3.6	13
<i>Internet use frequency (per day)</i>		
Under 1h	4.5	16
1h-3h (include 3h)	39.3	141
3h-6h (include 6h)	34.5	124
Over 6h	21.7	78
<i>How many social media app in your mobile</i>		
0	2.5	9
1-2	37	133
3-4	37.9	136
5-6	10.3	37
Over 7	12.3	44

Regression Modelling

The present research aims to investigate the factors motivating consumers to engage with travel-related social commerce. To explore and compare the relationship between variables, researchers will use ridge regression modelling, Linear least square regression modelling and Lasso regression modelling to compare the findings. The mathematical model can be shown in the form of the Multiple Linear Regression (MLR) expression presented below:

$$y = \beta_0 + \beta_1 x_1 + \beta_2 x_2 + \dots + \beta_k x_k + \varepsilon \quad (1)$$

The equation is presented as follows:

$$sc = \beta_0 + \beta_1 peou + \beta_2 is + \beta_3 ent + \beta_4 pu + \beta_5 si + \beta_6 age + \beta_7 fin + \varepsilon \quad (2),$$

When *sc* represents the explained variable (i.e. social commerce), x_1, x_2, \dots, x_k are the explanatory variables. In equation 2, the explanatory variables are *peou* (perceived ease of use), *fin* (financial status), *si* (social interaction), *is* (information seeking), *ent* (entertainment), *pu* (perceived usefulness) and *age*. $\beta_0, \beta_1, \dots, \beta_k$ serve as the parameters of the model and ε represents the specification error (in other words, the difference between the actual model and the specified model).

To start, the researcher assessed the multicollinearity of all the variables using the Variance Inflation Factor (VIF). A VIF value of 3.1 was found, which is higher than 2. A value that is over two indicates slight multicollinearity. The purpose of using such models for regression issues is to pinpoint the Best Linear Unbiased Estimator (BLUE). Therefore, the researcher in the present study employed Ordinary Least Squares (OLS) (Hayes & Cai, 2007) as a benchmark for the BLUE. Moreover, the search functions of the supervised machine learning algorithms worked well for the sample in the present research. The value *y* of social commerce is predicted in the present study based on observed characteristics *x* in the sample of *n* participants. In the regression algorithm of the present study, a loss function is inserted as an input (which is Mean Standard Error (MSE) in this case). Subsequently, the algorithm seeks to identify a function with low expected prediction loss on a *new* data point using the same distribution.

Moreover, to identify and address the regression problem outlined above, four methods are employed, namely OLS, Ridge regression (Hoerl & Kennard, 1970), Lasso regression (Tibshirani, 1996) and K-nearest neighbours (KNN) (Maltamo & Kangas, 1998). Cross-validation should also be performed. The key purpose is to highlight any variables that have a more significant effect on the social commerce measurement. Therefore, to ensure that the desired outcomes are obtained, the present research will attempt to regress the target variable (social commerce) and the OLS, ridge, Lasso and KNN regressions are used to analyse the relationships between the data and the target variable in order to assess the efficiency of different models.

Control Variables

The researchers selected age and financial status to be the control variables in the present work. With regard to online purchasing behaviours, age has been found to be a significantly influential factor. Different characteristics and online behaviours are demonstrated by consumers in different age groups. For instance, it is more probable that younger users (aged 18-29) will use online platforms than older individuals (Fox, 2004; Hargittai & Hinnant, 2008; Law, Kwok, & Ng, 2016; Madden, 2006). Spero and Stone (2004) point out that, since middle-aged individuals have higher incomes and access to credit, they may possess more purchasing power. Thus, it is evident that age can largely impact social commerce purchasing

behaviours and intentions.

Additionally, financial status can also influence social commerce purchase intentions. It is more probable that those better personal financial statuses will have higher online purchase intentions and a tendency to favour certain products and services. For instance, Tsakiridou *et al.* (2008) and Vapa-Tankosic *et al.* (2018) found that people in better financial situations are more likely to pay extra for organic products.

However, when adding age and financial situation into the estimation model, problems with multicollinearity could occur, since there is likely to be a positive relationship between age and financial status. The researchers thus performed a preliminary test to determine the extent of the correlation between financial status and age.

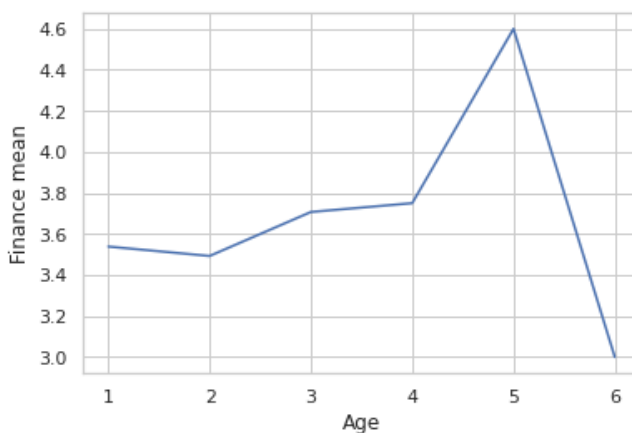

Figure 1: Preliminary correlation test between financial status and age

No relationship was found between these two variables and thus there is no evidence to suggest the personal financial situations of participants increased with age. For this reason, it is acceptable to include the two variables in the estimation model.

RESULTS

Ordinary Least Square (OLS) results

In the present research, the OLS linear model is used to model the determinates of Social Commerce. The statistical summary shows a determination coefficient (R-Squared) of 0.522, suggesting that the model is only representative of 52% of the sample data. The MSE value is thus 0.883. Additionally, we pinpointed the features that have a more significant effect on social commerce, which are presented in Figure 4, alongside their respective weightings. As can be seen in the figure, information seeking had the greatest impact (0.4163) followed by social interaction (0.2632). The factor with the third greatest significance was entertainment (0.228), followed by age (0.1772), perceived usefulness (0.1577), financial status (-0.1619) and perceived ease of use (0.1456)

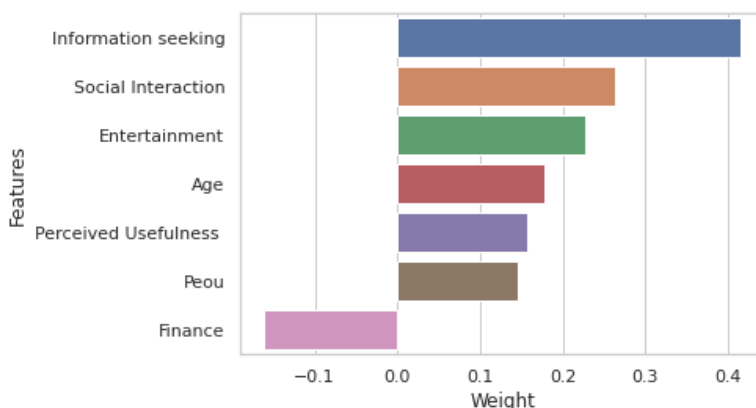

Figure 4: Significant influential factors and weightings (obtained by OLS)

Ridge regression results

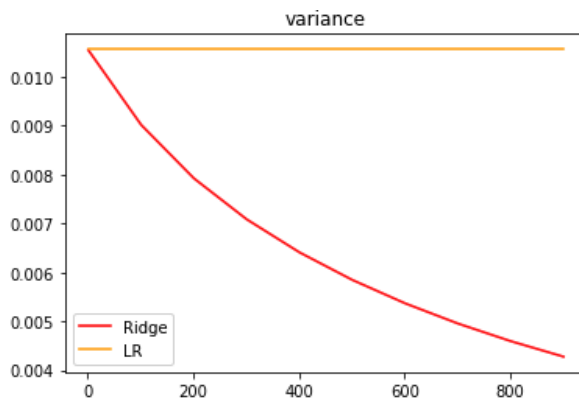

Figure 5: variance changes (OLS vs Ridge)

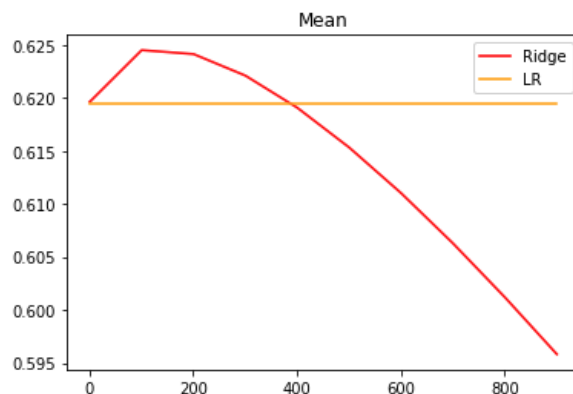

Figure 6: mean changes (OLS vs Ridge)

Ridge regression was also performed, after which the findings were compared with those of the OLS. It can be seen in Figure 6 that the mean value reached its peak when the cross-validation reached 150, after which a slight reduction was seen. Nonetheless, the range is below 0.005 (0.625-0.620). In other words, the level of multicollinearity between variables is minuscule. Additionally, there was a significant decrease in variance (see Figure 5). This indicates that, when cross-validation increases, the generalization error decreases. The ridge model has an R-squared value of 0.5682 and an MSE of 0.7978.

What’s more, the variables that have the most significant impact on social commerce purchase intentions will also be identified. These features are shown in Figure 7, alongside their corresponding weights according to the Ridge regression. As can be seen in the figure, perceived usefulness had the greatest significance (0.2434), followed by information seeking (0.2153). This was followed by social interaction (0.1855) and entertainment (0.1604), perceived ease of use (0.1455), age (0.085) and financial status (-0.0839).

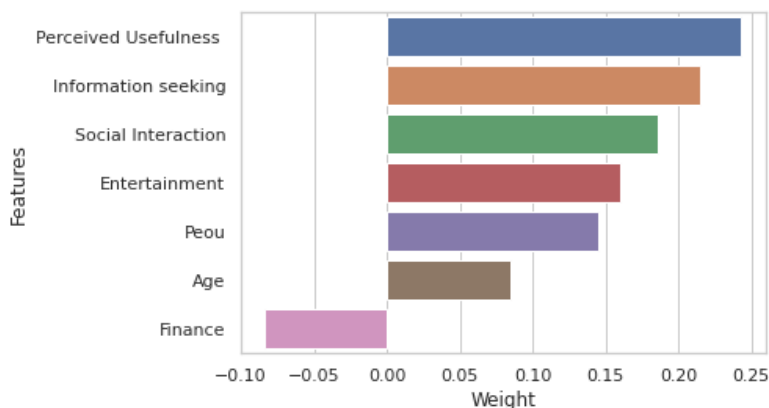

Figure 7: Significant influential factors and weightings (obtained via Ridge Regression)

Lasso Regression Results

Estimates made using Lasso regression indicate that coefficients are sparse. In other words, the number of variables for the given solution is dependently reduced. The statistics summary shows that the R-Squared value found using the Lasso regression is 0.5563. This suggests that of 55.63% of the data is represented through the model. Moreover, the model has an MSE is 0.8199. The variables that have the most significant impact on social commerce purchase intentions will also be

identified. These features are shown in Figure 8, alongside their corresponding weights according to the Lasso regression results. It can be seen that information seeking has the greatest significance (0.2737), followed by *perceived usefulness* (0.1885). The next most influential factors are *social interaction* (0.1629), *entertainment* (0.1397), *perceived ease of use* (0.069), *financial status* (-0.0547) and *age* (0.048).

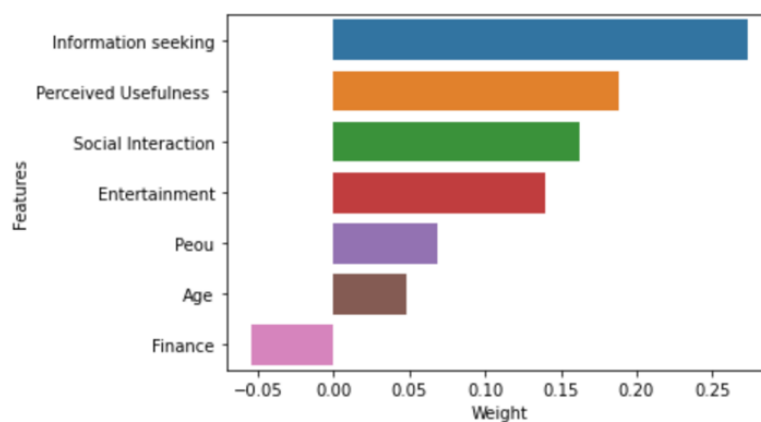

Figure 8: Significant influential factors and weightings (obtained via Lasso Regression)

KNN Regression Results

K-nearest neighbours (KNN) is a simple yet commonly-used algorithm that can predict the value of the target variable using a similarity measure (Arora, Bansal, Kandpal, Aswani, & Dwivedi, 2019). Identifying a value for the hyper-parameter k is vital for ensuring that the outcomes are accurate. Different k values are inputted into the model, after which the accuracy is assessed. This is evident in Figure 9, the latter of which shows that accuracy is highest for 24 neighbours. Regression analysis is conducted in order to obtain the results. The statistics summary shows that there is an R-Squared value of 0.5740. This means that only 57.4% of the data is represented by the model. Moreover, the MSE value is 0.7872 (when a neighbour is 24).

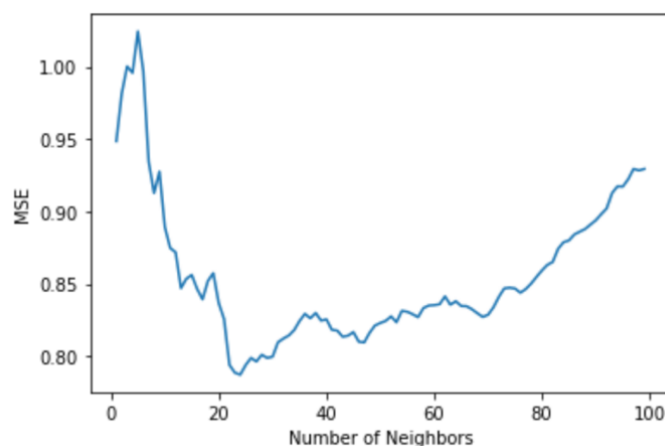

Figure 9: Accuracy for different 'K' neighbours

DISCUSSION AND CONCLUSION

The key objective of the present research was to investigate how consumers' social commerce purchase intentions are influenced by *social media usage motives* and *technologies acceptance factors*. We developed our hypotheses based on the UGT and TAM. These hypotheses focused on the relationships between purchase intentions and the following five factors: *information seeking*; *social interactions*, *perceived usefulness*, *perceived ease-of-use* and *entertainment*. Although the KNN model appears to perform better than the Ridge model, we selected the latter as our explanatory model as it is easier to interpret.

The findings demonstrate that there is a positive relationship between information seeking and social commerce purchase intentions and thus we accept hypothesis *H1*. This means that information seeking may generate favourable purchasing behaviour in the field of social commerce. Travellers purposefully choose specific sources to fulfil their need to seek information about their travels. Thus, individuals who engage with travel-related e-commerce will use social media sources (such as comments and recommendations made by other travellers) to find information and simply to entertain themselves. Lee and Ma (2012) asserted that social media can help individuals to find important information when planning trips, as well as

helping them to pass the time and to entertain themselves. Moreover, such individuals may use social media to create and uphold relationships with other people, from existing friends and family members to complete strangers.

The coefficient for entertainment using the Ridge regression model is 0.1604, which indicates that entertainment and social commerce purchase intentions have a positive relationship. Thus, we can accept hypothesis **H2** that social media use is positively influenced by entertainment motives since users engage with social media content for purposes of self-amusement and fun. The findings are similar to those of Siibak (2009), who identified the following factors as being key motivations for Facebook use: entertainment, companionship, professional advancement, social interaction and expressive information sharing.

The coefficient for entertainment using the Ridge regression model is 0.1855 which indicates that social interactions and social commerce purchase intentions have a positive relationship (**H3**). With regard to social commerce, those with internal motivation endorse the ideology of interactions with other users (for example, they believe that shopping experiences should be shared publicly). Therefore, they believe that information sharing about products is important. Such individuals will make significant efforts to engage with other users and to share information relating to products and services. This is in line with information provided in the literature review, that social media users engage in social interactions to seek information about travel (Chung *et al.*, 2015).

Moreover, there is a positive relationship between perceived usefulness and social commerce purchase intentions. Moreover, this variable also has the greatest significance value at 0.2434. This can be seen in the Ridge regression results. Luna-Nevarez and Torres (2015) explained that consumers' attitudes towards advertisements on social media can be positively impacted by perceived usefulness (**H4**). This is in line with the findings of Ahn *et al.* (2004) study, which revealed that perceived usefulness is positively related to consumer attitudes towards e-commerce websites and their subsequent purchase intentions.

The Ridge regression coefficient for perceived ease-of-use was found to be 0.1455. This shows that there is a positive relationship between perceived ease-of-use and social commerce purchase intention (**H5**). TAM appears to provide results that are consistent when it comes to social commerce attitudes and purchasing behaviours. The results are in line with those of previous studies and indicate that perceived usefulness and ease-of-use are the top priorities when using social commerce sites (Pavlou, 2003).

This study also revealed that age positively influences social commerce purchasing behaviours. To be more precise, as age increases, users are more likely to take part in travel-related social commerce. However, financial status was found to have a negative correlation with social commerce. This was found in all three regressions. This means that consumers in better financial positions are less likely to partake in travel-related social commerce.

Theoretical Contribution

The findings from the questionnaire on travel-related social commerce allowed the researchers to obtain a more profound theoretical understanding of the socio-psychological factors and technology system experience factors that impact users' social commerce purchase intentions. In our research model, we combined both personal motivation factors and technology-related factors, since this helped us to understand the socio-psychological constructs that underpin consumer social commerce purchase intentions. Moreover, technology-related factors were found to be more significant than personal usage motivation factors when the TAM and UGT were combined. This highlights the importance of technology in influencing social commerce participation.

Managerial Implications

The findings of the present study can help companies to develop their social commerce strategies by giving them a more profound understanding of consumer purchase behaviours. The integrated model presents different factors that can be manipulated by company managers and social commerce providers to influence consumers' purchase behaviours. Our study is very similar to previous ones that have used TAM to address usability issues. Additionally, it also contains UGT factors. If customers enjoy participating in social media, then entertainment is an important motivator for social commerce. Managerial teams may wish to employ customer contact employees to ask consumers about their previous TSM experiences. They can then compare the responses to online reviews and make note of the feedback.

Limitations and Recommendations for Future Research

It is important to note that the present research had several limitations. These limitations should be considered in future research. Firstly, the participants of the study were all Chinese and thus it is impossible to generalize the findings and conclusions. In future, researchers should use participants from different countries, as this will enable them to compare the results and determine whether culture has any influence on social commerce. Secondly, the different features of different sectors were not taken into account. These unique factors can have different influences on the hotel and restaurant purchase intentions. In future, researchers may wish to explore different travel-related sectors so that they can identify any differences in the impacts exerted by the five influential factors.

REFERENCE

- [1] Ahn, T., Ryu, S., & Han, I. (2004). The impact of the online and offline features on the user acceptance of Internet shopping malls. *Electronic Commerce Research and Applications*, 3(4), 405-420.
- [2] Ali, F. (2016). Hotel website quality, perceived flow, customer satisfaction and purchase intention. *Journal of Hospitality and Tourism Technology*, 7(2), 213-228.
- [3] Amblee, N., & Bui, T. (2011). Harnessing the influence of social proof in online shopping: The effect of electronic word of mouth on sales of digital microproducts. *International Journal of electronic commerce*, 16(2), 91-114.
- [4] Arora, A., Bansal, S., Kandpal, C., Aswani, R., & Dwivedi, Y. (2019). Measuring social media influencer index-insights from Facebook, Twitter and Instagram. *Journal of Retailing and Consumer Services*, 49, 86-101.
- [5] Bauer, H. H., Reichardt, T., Barnes, S. J., & Neumann, M. M. (2005). Driving consumer acceptance of mobile marketing: A theoretical framework and empirical study. *Journal of electronic commerce research*, 6(3), 181.
- [6] Cha, J. (2009). Shopping on social networking Web sites: Attitudes toward real versus virtual items. *Journal of interactive advertising*, 10(1), 77-93.
- [7] Chen, C.-C., & Chang, Y.-C. (2018). What drives purchase intention on Airbnb? Perspectives of consumer reviews, information quality, and media richness. *Telematics and Informatics*, 35(5), 1512-1523.
- [8] Chen, Y.-C., Shang, R.-A., & Li, M.-J. (2014). The effects of perceived relevance of travel blogs' content on the behavioral intention to visit a tourist destination. *Computers in Human Behavior*, 30, 787-799. doi: 10.1016/j.chb.2013.05.019
- [9] Chung, N., Han, H., & Koo, C. (2015). Adoption of travel information in user-generated content on social media: the moderating effect of social presence. *Behaviour & Information Technology*, 34(9), 902-919.
- [10] Chung, N., Song, H. G., & Lee, H. (2017). Consumers' impulsive buying behavior of restaurant products in social commerce. *International Journal of Contemporary Hospitality Management*, 29(2), 709-731.
- [11] Curty, R. G., & Zhang, P. (2011). Social commerce: Looking back and forward. *Proceedings of the American Society for Information Science and Technology*, 48(1), 1-10.
- [12] Davis, F. D. (1989). Perceived usefulness, perceived ease of use, and user acceptance of information technology. *MIS quarterly*, 13(3), 319-340. doi:10.2307/249008
- [13] Diddi, A., & LaRose, R. (2006). Getting hooked on news: Uses and gratifications and the formation of news habits among college students in an Internet environment. *Journal of Broadcasting & Electronic Media*, 50(2), 193-210.
- [14] Dix, S., Phau, I., Jamieson, K., & Shimul, A. S. (2017). Investigating the drivers of consumer acceptance and response of SMS advertising. *Journal of Promotion Management*, 23(1), 62-79.
- [15] Fox, S. (2004). *Older Americans and the Internet: Just 22% go online, but their enthusiasm for email and search may inspire their peers to take the leap*: Pew Internet & American Life Project. <https://www.pewresearch.org/internet/2004/03/28/older-americans-and-the-internet/>
- [16] Gao, Q., & Feng, C. (2016). Branding with social media: User gratifications, usage patterns, and brand message content strategies. *Computers in Human Behavior*, 63, 868-890.
- [17] Hajli, M. (2013). A research framework for social commerce adoption. *Information Management & Computer Security*, 21(3), 144-154.
- [18] Hajli, N. (2015). Social commerce constructs and consumer's intention to buy. *International Journal of Information Management*, 35(2), 183-191. doi: 10.1016/j.ijinfomgt.2014.12.005
- [19] Hargittai, E., & Hinnant, A. (2008). Digital inequality: Differences in young adults' use of the Internet. *Communication research*, 35(5), 602-621.
- [20] Harrigan, P., Evers, U., Miles, M., & Daly, T. (2017). Customer engagement with tourism social media brands. *Tourism Management*, 59, 597-609.
- [21] Hayes, A. F., & Cai, L. (2007). Using heteroskedasticity-consistent standard error estimators in OLS regression: An introduction and software implementation. *Behavior research methods*, 39(4), 709-722.
- [22] Hoerl, A. E., & Kennard, R. W. (1970). Ridge regression: Biased estimation for nonorthogonal problems. *Technometrics*, 12(1), 55-67.
- [23] Hsu, C.-L., Chang, K.-C., & Chen, M.-C. (2012). The impact of website quality on customer satisfaction and purchase intention: perceived playfulness and perceived flow as mediators. *Information Systems and e-Business Management*, 10(4), 549-570.
- [24] Hu, X., Chen, X., & Davison, R. M. (2019). Social support, source credibility, social influence, and impulsive purchase behavior in social commerce. *International Journal of Electronic Commerce*, 23(3), 297-327.
- [25] Hu, X., Huang, Q., Zhong, X., Davison, R. M., & Zhao, D. (2016). The influence of peer characteristics and technical features of a social shopping website on a consumer's purchase intention. *International Journal of Information Management*, 36(6), 1218-1230.
- [26] Jiang, P. (2009). Consumer adoption of mobile internet services: An exploratory study. *Journal of Promotion Management*, 15(3), 418-454.
- [27] Katz, E. (1974). Utilization of mass communication by the individual. In J.G. Blumler & E. Katz (Eds.) *The Uses of Mass Communications: Current Perspectives on Gratifications Research*, 19-32.
- [28] Katz, E., Blumler, J. G., & Gurevitch, M. (1973). Uses and gratifications research. *The Public Opinion Quarterly*, 37(4), 509-523.
- [29] Kaye, B. K. (1998). Uses and gratifications of the world wide web: From couch potato to web potato. *Atlantic Journal of Communication*, 6(1), 21-40.

- [30] Kim, D. (2013). Under what conditions will social commerce business models survive? *Electronic Commerce Research and Applications*, 12(2), 69-77.
- [31] Kim, M. J., Chung, N., Lee, C.-K., & Preis, M. W. (2016). Dual-route of persuasive communications in mobile tourism shopping. *Telematics and Informatics*, 33(2), 293-308.
- [32] Kim, S., & Park, H. (2013). Effects of various characteristics of social commerce (s-commerce) on consumers' trust and trust performance. *International Journal of Information Management*, 33(2), 318-332.
- [33] Koufaris, M. (2002). Applying the technology acceptance model and flow theory to online consumer behavior. *Information Systems Research*, 13(2), 205-223.
- [34] Ku, Y.-C., Chu, T.-H., & Tseng, C.-H. (2013). Gratifications for using CMC technologies: A comparison among SNS, IM, and e-mail. *Computers in Human Behavior*, 29(1), 226-234.
- [35] Kwahk, K.-Y., & Kim, B. (2017). Effects of social media on consumers' purchase decisions: evidence from Taobao. *Service Business*, 11(4), 803-829.
- [36] Law, M., Kwok, R. C.-W., & Ng, M. (2016). An extended online purchase intention model for middle-aged online users. *Electronic Commerce Research and Applications*, 20, 132-146.
- [37] Lee, C. S., & Ma, L. (2012). News sharing in social media: The effect of gratifications and prior experience. *Computers in Human Behavior*, 28(2), 331-339.
- [38] Liang, T.-P., Ho, Y.-T., Li, Y.-W., & Turban, E. (2011). What drives social commerce: The role of social support and relationship quality. *International Journal of Electronic Commerce*, 16(2), 69-90.
- [39] Liang, T.-P., & Turban, E. (2011). Introduction to the special issue social commerce: a research framework for social commerce. *International Journal of Electronic Commerce*, 16(2), 5-14.
- [40] Lin, S.-W., & Liu, Y.-C. (2012). The effects of motivations, trust, and privacy concern in social networking. *Service Business*, 6(4), 411-424.
- [41] Luna-Nevarez, C., & Torres, I. M. (2015). Consumer attitudes toward social network advertising. *Journal of Current Issues & Research in Advertising*, 36(1), 1-19.
- [42] Luo, M. M., Chea, S., & Chen, J. S. (2011). Web-based information service adoption: A comparison of the motivational model and the uses and gratifications theory. *Decision Support Systems*, 51(1), 21-30.
- [43] Madden, M. (2006). *Internet penetration and impact: Pew Internet & American Life Project*. <https://www.pewresearch.org/internet/2006/04/26/internet-penetration-and-impact/>
- [44] Maltamo, M., & Kangas, A. (1998). Methods based on K-Nearest Neighbor Regression in the prediction of basal area diameter distribution. *Canadian Journal of Forest Research*, 28(8), 1107-1115.
- [45] Marsden, P., & Chaney, P. (2012). *The Social Commerce Handbook: 20 Secrets for Turning Social Media into Social Sales*. McGraw Hill Professional.
- [46] Merisavo, M., Kajalo, S., Karjaluoto, H., Virtanen, V., Salmenkivi, S., Raulas, M., & Leppäniemi, M. (2007). An empirical study of the drivers of consumer acceptance of mobile advertising. *Journal of Interactive Advertising*, 7(2), 41-50.
- [47] Moon, J.-W., & Kim, Y.-G. (2001). Extending the TAM for a World-Wide-Web context. *Information & Management*, 38(4), 217-230.
- [48] Ng, C. S.-P. (2013). Intention to purchase on social commerce websites across cultures: A cross-regional study. *Information & Management*, 50(8), 609-620.
- [49] Ngai, E. W., Tao, S. S., & Moon, K. K. (2015). Social media research: Theories, constructs, and conceptual frameworks. *International Journal of Information Management*, 35(1), 33-44.
- [50] Nusair, K. K., Bilgihan, A., Okumus, F., & Cobanoglu, C. (2013). Generation Y travelers' commitment to online social network websites. *Tourism Management*, 35(0), 13-22. doi: 10.1016/j.tourman.2012.05.005
- [51] Olbrich, R., & Holsing, C. (2011). Modeling consumer purchasing behavior in social shopping communities with clickstream data. *International Journal of Electronic Commerce*, 16(2), 15-40.
- [52] Papacharissi, Z., & Rubin, A. M. (2000). Predictors of internet use. *Journal of Broadcasting & Electronic Media*, 44(2), 175-196.
- [53] Park, D.-B., & Yoon, Y.-S. (2009). Segmentation by motivation in rural tourism: A Korean case study. *Tourism Management*, 30(1), 99-108. doi: 10.1016/j.tourman.2008.03.011
- [54] Park, N., Kee, K. F., & Valenzuela, S. (2009). Being immersed in social networking environment: Facebook groups, uses and gratifications, and social outcomes. *Cyberpsychology & Behavior*, 12(6), 729-733.
- [55] Pavlou, P. A. (2003). Consumer acceptance of electronic commerce: Integrating trust and risk with the technology acceptance model. *International Journal of Electronic Commerce*, 7(3), 101-134.
- [56] Phang, C. W., Zhang, C., & Sutanto, J. (2013). The influence of user interaction and participation in social media on the consumption intention of niche products. *Information & Management*, 50(8), 661-672.
- [57] Ponte, E. B., Carvajal-Trujillo, E., & Escobar-Rodríguez, T. (2015). Influence of trust and perceived value on the intention to purchase travel online: Integrating the effects of assurance on trust antecedents. *Tourism Management*, 47, 286-302.
- [58] Porter, C. E., & Donthu, N. (2006). Using the technology acceptance model to explain how attitudes determine Internet usage: The role of perceived access barriers and demographics. *Journal of Business Research*, 59(9), 999-1007.
- [59] Pöyry, E., Parvinen, P., & Malmivaara, T. (2013). Can we get from liking to buying? Behavioral differences in hedonic and utilitarian Facebook usage. *Electronic Commerce Research and Applications*, 12(4), 224-235.
- [60] Sharma, S., & Crossler, R. E. (2014). Disclosing too much? Situational factors affecting information disclosure in social

- commerce environment. *Electronic Commerce Research and Applications*, 13(5), 305-319.
- [61] Sheldon, P. (2008). Student favorite: Facebook and motives for its use. *Southwestern Mass Communication Journal*, 23(2).
- [62] Smock, A. D., Ellison, N. B., Lampe, C., & Wohn, D. Y. (2011). Facebook as a toolkit: A uses and gratification approach to unbundling feature use. *Computers in Human Behavior*, 27(6), 2322-2329. doi: 10.1016/j.chb.2011.07.011
- [63] Sturiale, L., & Scuderi, A. (2013). Evaluation of social media actions for the agrifood system. *Procedia Technology*, 8, 200-208.
- [64] Tarkang, M. E., Alola, U. V., Nange, R. Y., & Öztüren, A. (2020). Investigating the factors that trigger airline industry purchase intention. *Current Psychology*. <https://doi.org/10.1007/s12144-020-00815-z>
- [65] Tibshirani, R. (1996). Regression shrinkage and selection via the lasso. *Journal of the Royal Statistical Society: Series B (Methodological)*, 58(1), 267-288.
- [66] Um, N.-H. (2019). Antecedents and consequences of consumers' attitude toward social commerce sites. *Journal of Promotion Management*, 25(4), 500-519.
- [67] Wagner, C., & Majchrzak, A. (2006). Enabling customer-centricity using wikis and the wiki way. *Journal of Management Information Systems*, 23(3), 17-43.
- [68] Wang, Y. S., Wang, Y. M., Lin, H. H., & Tang, T. I. (2003). Determinants of user acceptance of Internet banking: an empirical study. *International Journal of Service Industry Management*, 14(5), 501-519.
- [69] Whiting, A., & Williams, D. (2013). Why people use social media: a uses and gratifications approach. *Qualitative Market Research: An International Journal*, 16(4), 362-369.
- [70] Yahia, I. B., Al-Neama, N., & Kerbache, L. (2018). Investigating the drivers for social commerce in social media platforms: Importance of trust, social support and the platform perceived usage. *Journal of Retailing and Consumer Services*, 41, 11-19.
- [71] Zhang, K. Z., & Benyoucef, M. (2016). Consumer behavior in social commerce: A literature review. *Decision Support Systems*, 86, 95-108

An Integrated Computer Vision Based OOH Audience Measurement System

(Work in Progress)

Jialou Wang*, Northumbria University, United Kingdom, jialou.wang@northumbria.ac.uk

Honglei Li, Northumbria University, United Kingdom, honglei.li@northumbria.ac.uk

Shan Shan, Northumbria University, United Kingdom, shan.shan@northumbria.ac.uk

ABSTRACT

Out of Home (OOH) advertising models through deep learning method with demographical information such as gender, age, etc. While a more comprehensive model would involve fine-tuned information from audience. This paper proposed a subdivided apparel recognition model to enhance the existing audience measurement for OOH. SVM accompanied by Libra R-CNN and histogram intersection kernels is adopted alongside advertising board-mounted cameras, which obtain unprocessed data from which gender, age and other demographic features are discerned to determine viewers of particularly clothing advertising. Pervasive adoption for contactless consumer engagement, customised content display and consumer analysis is possible through the amalgamation of results, while audience measurement via digital advertising panels can be more effectively understood by OOH companies and businesses.

Keywords: Face recognition; gender classification; age classification; apparel classification

* Corresponding author

INTRODUCTION

Out of Home (OOH) advertising plays an important role in marketing field. A considerable proportion of businesses and companies' general spending on advertising focuses on OOH, which seeks to provide advertising material in internal (business buildings) and external (street advertising) environments to target populations (Costache, Popescu, Mocanu, & Ichim, 2020; A. Roux & Van der Waltd, 2014). Attracting possible consumers and advertising goods and services through low-cost, appealing and innovative methods is the focus of marketers, advertisers and companies due to contemporary high-tech developments. The effect of OOH advertising measurement is a crucial yet challenging activity for advertisers. The existing OOH audience measurement methods involves the computer vision method to extract precise audience measurement information from OOH advertising. Personal behaviour, demographic information as well as approximation of the present audience may all be derived through identifying, classifying and assessing individuals' faces through the computer vision techniques. Monitoring of gestures and facial expressions among viewers are the primary topics with regards to OOH advertising's audience measurement. Ethnic identity, gender, age and other demographic variables are explored in relation to facial expressions (Bekhouché *et al.*, 2015; Hjelmås & Low, 2001; Khryashchev *et al.*, 2014). Cutting edge findings relating to several competitive standards have been presented based on the identification of emotions, gender and age of viewers based on applying several deep convolutional neural networks (Dehghan *et al.*, 2017). Meanwhile, deriving a viewer's age based on their appearance in images is possible when insufficient data about their genuine biological age is available with the principal issue of developing dedicated age recognition databanks (Khryashchev *et al.*, 2014). Furthermore, audience measurement can be enhanced through the extraction of various facial features, for instance gesture, body positioning, body language, attention and in-viewing duration, as well as dwell duration (Baysal, Kurt, & Duygulu, 2010; Chen *et al.*, 2009; Ravník & Solina, 2013). The current studies for the OOH audience measurement call for a more integrated dimension with richer information, such as audience demographic dimensions, or consumers' self-identification of clothing. This research proposed and developed a subdivided apparel identification model for augmented OOH audience measurement. In this model, data related with viewers' clothing behaviour will be collected and classified according to its formal, or relaxed, or sports style and so forth. In combination with previous algorithm of a single or multiple extant gender and age algorithms, the model will provide a more comprehensive estimation of audience measurements for OOH.

RELATED WORKS

Opportunity to Contact Measurement

In terms of OOH advertising efficacy's measurement, the principal index used is opportunity to contact (OTC). The sample population's trajectories are measured via satellite tracking apparatus, with highly accurate data regarding a person's position being garnered from such apparatus. Nevertheless, to provide precise findings, cautious selection of the sample is required, with significant expenditure potentially incurred through the process. Additionally, establishing the number of cell phone users walking through a location is an alternative approach, with the cell phone trajectories determined on the basis of timestamp information and associated likely position each time a cellular network is linked to by a cell phone (Quercia, Di Lorenzo, Calabrese, & Ratti, 2011). A further means of measuring the success of OOH advertising has been questionnaires, with every journey made by a sample population recorded by them. For example, the success of car advertising was investigated on the

basis of 400 questionnaires in Roux's study (2014). Moreover, the success of advertising near Hong Kong city centre metro station exits was investigated through 408 questionnaires completed by tourists and citizens in Chan and Fung's research (Chan & Fung, 2013). Regardless, precision may be markedly affected by the duration of time between the sample population's journey and when the questionnaire was completed by them.

Measuring OOH advertising success may also be done using the further significant index of eye-hit rate. Through obtaining pedestrians' location data it is possible that the size of an audience may be approximately determined via the established OTC techniques explained previously, whereas OOH advertising's direct views can be determined according to the eye-hit rate. The number of individuals looking a minimum of one time at the panel can be measured as the eye-hit rate, utilising eye-tracking technology. The correlation between hit rate and the features of an advertisement, for instance panel area, orientation and distance, is investigated through an eye-tracking technology approach devised by Barber, Sanderson and Dickenson (Barber, Sanderson, & Dickenson, 2008), with foot traffic and drivers being categorised by the researchers. One shortcoming is that marketers find information regarding group, ethnicity, gender, age and other demographics significant, which was not collected in depth during the study.

Audience Measurement

Movement detection and facial detection are primarily focused on audience measurement. Furthermore, automatic suggestion of goods, clothing search and retrieval engines, clothing identification and other e-commerce deep learning methods are being implemented by fashion-associated organisations (Seo & Shin, 2019). Additionally, because numerous visual signals may be comprehended, for example group-individual proxemics, emotions, dwell duration, free gaze estimation and demographics data, critical prominence is being given to pattern recognition and computer vision technology for audience measurement. Recognition rests crucially on such dynamics as the significant internal diversity in ethnic, age, female and class groupings, as well as attained subjects limited spatial resolution.

The existing literature explores numerous face detection strategies (Feraund *et al.*, 2001; Liu & Peng, 2010; Yang, Kriegman, & Ahuja, 2002). When detecting faces in varying positions an effective approach is analysing geometrical facial features, while for discerning faces in low-quality pictures or small faces a holistic representation-based detection algorithm is superior, as a representation-focused classification of face detection techniques shows (Hsu, Abdel-Mottaleb, & Jain, 2002). Two additional subcategories of a feature-orientated strategy's formulation can be identified. Because the discernment of a face within a busy environment is a common face detection issue, colour, greyscale and such pixel features can be subject to an initial low-level assessment for visual features' segmentation (Hjelmås & Low, 2001). Within computer vision applications, the foremost primary characteristic is edges; identification of facial features is undertaken on the basis of assessing line drawings of faces extracted from images as a form of edge analysis. For instance, research offers a thorough collection of objectives for edge points' effective computation (Canny, 1986). With negligible assumptions adopted regarding the solution's form, the detector's requisite conduct may be defined through the sufficiently accurate objectives.

Additionally, features such as grey and colour data can be adopted. Facial regions adjacent to lips, pupils and eyebrows are typically lighter in shade. Low-level grey-scale thresholding enables the attainment of dark areas' extraction. Discerning faces within grey-scale photographs is possible via a neural network algorithm (Rowley, Baluja, & Kanade, 1998). Every input window can be assessed by the neural network's 'router', prior to the 'detector' network processing it. The face angle is returned by the router if a face is identified in the window. Compared with thoroughly attempting every possible orientation, such a method is markedly faster and returns a more limited number of erroneous detections, given that per image location there is just a single application of the detector network.

Detecting the presence of an object is more effective based on colour, despite a simple discernment of image features being possible through grey data. People's skin hue provides a dependable characteristic under uncontrolled, complicated conditions, as the self-adaptive face detection algorithm for discerning skin colour shows. This is because a tremendous volume of skin colour pixels were initially used in HS colour space to construct the histogram skin colour model, followed by the adoption of histogram back projection to introduce skin colour segmentation for the images, which following thresholding enables the acquisition of a binary picture of the skin colour region.

Classification

Computer vision studies are placing greater emphasis on determining ethnicity, gender, age and other demographic variables. Assessing human faces for characteristic signs of ageing such as spots and wrinkles is pervasively undertaken using colour discernment and edge discernment methods. Telling apart babies and adolescents from elderly people was possible using the wrinkle index devised in (Kwon & da Vitoria Lobo, 1999), based on skin wrinkle analysis and cranio-facial development theory for determining age. Furthermore, research has devised a way of identifying more likely locations using a Marked Point Process (MPP) model, with a Reversible Jump Markov Chain Monte Carlo (RJMCMC) algorithm adopted with a prior probability model to limit line segments' features (Batoov & Chellappa, 2012). Presently, discerning audience data is commonly undertaken on the basis of gender and age classification.

A face's 3D composition, inter-characteristic configural relationships, as well as local features for example skin texture, eyebrows and facial hair, are three data classifications for faces that are used to undertake gender recognition. Gender

classification techniques, face detection and skin area detection on the basis of colour space, are gender classification's principal concerns. Ravi and Wilson (2010) mention undertook experimental investigation of gender classification and face detection's relationship, while the use of manually aligned faces for gender classification via an Adaboost system has been assessed by Baluja and Rowley (2007), who altered facial image's rotation, translation and scaling to undertake a meticulous contrast of SVM and Adaboost via experimentation.

Nevertheless, in terms of viewer measurement, age and gender are fundamental demographic features, meaning that we can ask whether OOH with more precise estimations can be achieved when additional viewer data reflecting other features is derived from computer vision. For example, an image may include an individual wearing or holding numerous items of apparel, which can be identified through various methods as existing research shows. One instance is the adoption of varied previous information concerning fashion apparel such as aspect ratio, size and location, to develop an R-CNN framework (Hara, Jagadeesh, & Piramuthu, 2016). Meanwhile, deep learning to discern learned features and semantic features to engage in apparel retrieval is an original strategy devised by Liu, Zhou, and Tang (2016). YOLO2 was used as the basis of the Apparel object detection system developed by Feng *et al.* (2018), with a 56ms per image detection speed, 0.73 mean recall rate, as well as 0.839 mean precision being accomplished.

Through this study, identification of the attire classes through Libra R-CNN is undertaken, developing an apparel recognition model subdivision and providing an in-depth clarification of the process.

METHODOLOGY

As a means of augmenting the OOH viewer measurement system, identification of the apparel classes via a subdivided apparel recognition model is the approach developed here. Accordingly, the apparel, gender and age classification model are explained here. The mining of significant and regular trends and their association rules through static databanks is the pervasive approach adopted for FP-tree, Apriori and other data mining apparatus. Through adopting association rules, clustering and classification algorithms, the mining of databanks comprising of continuous or growing, timely and real-time data will be concentrated on in this study. An individuals' mouth, nose, eyes and other major features are used to discern objects through feature-focused techniques. The location of such features in relation to each other is largely fixed, meaning that the geometric connections may be used for facial description. Nevertheless, to derive the pertinent facial features, the image must be pre-processed. Instant video footage will be obtained from a camera attachedé to ée OOH display board. Tracking individuals walking past will be undertaken through person detection, with the extent to which the tracked individuals are looking at the camera as they walk past being determined through OTC. Based on the aforementioned feature vector representations, training of the standard linear SVM (Cortes & Vapnik, 1995) will be undertaken, which is used to undertake classification. Discrete investigation of every descriptor will be made, or single long feature vectors will be formed through concatenating multiple descriptors. Accordingly, two stages of the research will be carried out to achieve this. The pre-processing phase will involve: elimination of neck, hair and other areas extrinsic to the face; automated or manual facial geometric alignment; brightness and contrast normalising, for example via histogram equalisation; lowering the pixel number through downsizing; pixel value normalising or rescaling, for instance to unit variance and zero mean.



Fig.1: Face landmarks trained on HELEN dataset

The second stage will implement Zhu and Ramanan (2012) reliable facial feature detector as a means of categorising viewers' apparel, age and gender features. The nose, mouth and eye corners are among 68 particular facial features. Alignment of the images is possible through a theoretical determination of the affine transformation, based on choosing the ideal coordinates per point. Nevertheless, practically speaking the alignment outcomes lack stability, due to flaws in face shape variability and point localisations. Moreover, the minimum window size and associated sliding step will be established via the Viola-Jones

algorithm, when an image comprises of numerous individuals. Per step, both horizontal and vertical window sliding will be undertaken for the selected window size, while application of a collection of N face recognition filters will be carried out. A face will be discerned in the specific window if a positive response is provided by a filter. The process will be ceased if the maximum size of the window is reached. If this is not the case, then the subsequent selected size for the window and related sliding step should be moved to.



Fig.2: An illustration of exact clothing retrieval



Fig.3: An example of clothing attribution recognition

A classification or regression problem may be defined for the age estimator; viewer classification on the basis of various age groups to approximate age is sufficient for our research. Evidently, even if human emulation is carried out, it is challenging to use facial images in order to approximate age. Health and numerous other extrinsic variables, as well as genetic factors, influence the distinctive aging process of individuals. SVM will be adopted accompanied by histogram intersection kernels. A process of GP multi-class classification will be undertaken on the basis of the one-vs-all method, typical for SVM classification systems, while training of the binary classifier with label regression is carried out per class m ; positive instance are all m images, while negative instances are any others that are left (Rodner *et al.*, 2017). Furthermore, classification depth adds intricacy and there are numerous apparel features, thus increasing the challenge of apparel classification. Essentially, discerning between alike classes may be a vague process, with difficulties in multi-class apparel classification. In this regard, object discernment will be carried out on the basis of the newly devised Libra R-CNN model (Pang *et al.*, 2019). Varied geometric priors will be applied to fashion apparel size, location and aspect ratios. Through applying R-CNN alongside the new balanced L1 Loss, diminishment of the disparity at the objective, features and sample level is possible. This can be shown in the equation:

$$L_b(x) = \begin{cases} \frac{\alpha}{b} (b|x| + 1) \ln(b|x| + 1) - \alpha|x| & \text{if } |x| < 1 \\ \gamma|x| + C & \end{cases} \quad (1)$$

Restriction of parameters γ , α , and b is on the basis of the following:

$$\alpha \ln(b + 1) = \gamma \quad (2)$$

On this basis, our experiment will establish the default parameters of γ and α . Additionally, two classes will be determined for our apparel classification: one is the pattern and colour of apparel, for instance ‘floral’, ‘green’, ‘pink’ and so forth, while the second is the type of apparel, for example ‘jeans’, ‘skirt’, ‘hat’ and so forth. It must be pointed out that distinct apparel may be deemed identical, while identical apparel may be deemed as distinct, based on the image (Seo & Shin, 2019). Additionally, tights or leggings for example may appear ambivalent in terms of classification due to their comparable feature (Hara, Jagadeesh & Piramuthu 2016). Therefore, apparel’s heterarchical nature will be determined in the image classification algorithms, enabling a contrast with Libra-RCNN to be made, so that the images’ shortcomings can be resolved (Seo & Shin, 2019).

EXPECT RESULT AND CONCLUSIONS

As a means of augmenting the OOH viewer measurement system, a subdivided apparel recognition model for discerning apparel categories has been posited in this research. Initially, we sought to determine the location of every passer-by's face that appeared irrespective of their positioning, as well as determining attention duration through discerning the viewer's head orientation, through applying facial detection methods, thus differing from established OOH research. Following this, the raw databank was analysed to extract apparel features in addition to gender, age and other demographic features. Accordingly, the ability to discern an individual's age group and gender, as well as whether they are orientated towards the advertising panel was possible, thus responding to the extant research shortcomings through providing relevant results. Moreover, the principal colour (blue, pink and so forth), apparel pattern (plaid, spotted, floral and so forth), as well as general style (jumper, skirt, coat, dress shirt and so forth) is discernible, responding to issues regarding apparel object data.

Based on the results being assessed, important implications for both theory and application will be derived from the research. A crucial aspect of audience measurement is the accurate identification of amalgamated demographic data such as age and gender, as well as discernment of particular apparel. Furthermore, enhanced comprehension of possible consumers is achieved when viewers of advertising can be precisely classified according to apparel subdivisions.

OOH organisations in particular will benefit from the applied contributions of this study, specifically the measurement of viewers' demographic data as part of advertainment marketing which enables the subdivided apparel recognition model's results to surpass the potential assumed by organisations. Essentially, immediate term advantages of utilising consumers' demographic data for amending marketing approaches will be derived by OOH advertising organisations.

REFERENCES

- [1] Baluja, S., & Rowley, H. A. (2007). Boosting sex identification performance. *International Journal of computer vision*, 71(1), 111-119.
- [2] Barber, P., Sanderson, M., & Dickenson, A. (2008). Postar visibility research. *School of Psychology Birkbeck College, London*. Retrieved from <http://route.org.uk/wp-content/uploads/2017/07/Visibility-Research-Visibility-Hit-Rates-for-Poster-Panels.pdf> (December 1, 2020).
- [3] Batool, N., & Chellappa, R. (2012, October). Modeling and detection of wrinkles in aging human faces using marked point processes. In *European Conference on Computer Vision* (pp. 178-188). Springer, Berlin, Heidelberg.
- [4] Baysal, S., Kurt, M. C., & Duygulu, P. (2010, August). Recognizing human actions using key poses. In *2010 20th International Conference on Pattern Recognition* (pp. 1727-1730). IEEE.
- [5] Bekhouche, S. E., Ouafi, A., Benlamoudi, A., Taleb-Ahmed, A., & Hadid, A. (2015, May). Facial age estimation and gender classification using multi level local phase quantization. In *2015 3rd International Conference on Control, Engineering & Information Technology (CEIT)* (pp. 1-4). IEEE.
- [6] Canny, J. (1986). A computational approach to edge detection. *IEEE Transactions on Pattern Analysis and Machine Intelligence*, 8(6), 679-698..
- [7] Chan, K., & Fung, M. S. (2013). Effectiveness of subway advertising in Hong Kong. *Journalism and Mass Communication*, 3(12), 757-767.
- [8] Chen, Q., Malric, F., Zhang, Y., Abid, M., Cordeiro, A., Petriu, E. M., & Georganas, N. D. (2009, July). Interacting with digital signage using hand gestures. In *International Conference Image Analysis and Recognition* (pp. 347-358). Springer, Berlin, Heidelberg.
- [9] Cortes, C. & Vapnik, V. (1995). Support-vector networks. *Machine Learning*, 20(3), 273-297.
- [10] Costache, A., Popescu, D., Mocanu, S., & Ichim, L. (2020, June). Target Audience Response Analysis in Out-of-home Advertising Using Computer Vision. In *2020 12th International Conference on Electronics, Computers and Artificial Intelligence (ECAI)* (pp. 1-6). IEEE.
- [11] Dehghan, A., Ortiz, E. G., Shu, G., & Masood, S. Z. (2017). Dager: Deep age, gender and emotion recognition using convolutional neural network. *arXiv:1702.04280v2*. <https://arxiv.org/pdf/1702.04280.pdf>
- [12] Feng, Z., Luo, X., Yang, T., & Kita, K. (2018, December). An object detection system based on YOLOv2 in fashion apparel. In *2018 IEEE 4th International Conference on Computer and Communications (ICCC)* (pp. 1532-1536). IEEE..
- [13] Feraund, R., Bernier, O. J., Viallet, J. E., & Collobert, M. (2001). A fast and accurate face detector based on neural networks. *IEEE Transactions on Pattern Analysis and Machine Intelligence*, 23(1), 42-53.
- [14] Hara, K., Jagadeesh, V., & Piramuthu, R. (2016, March). Fashion apparel detection: the role of deep convolutional neural network and pose-dependent priors. In *2016 IEEE Winter Conference on Applications of Computer Vision (WACV)* (pp. 1-9). IEEE.
- [15] Hjelmas, E., & Low, B. K. (2001). Face detection: A survey. *Computer Vision and Image Understanding*, 83(3), 236-274.
- [16] Hsu, R. L., Abdel-Mottaleb, M., & Jain, A. K. (2002). Face detection in color images. *IEEE Transactions on Pattern Analysis and Machine Intelligence*, 24(5), 696-706.
- [17] Khryashchev, V., Ganin, A., Stepanova, O., & Lebedev, A. (2014, October). Age estimation from face images: challenging problem for audience measurement systems. In *Proceedings of 16th Conference of Open Innovations Association FRUCT* (pp. 31-37). IEEE.
- [18] Kwon, Y. H., & da Vitoria Lobo, N. (1999). Age classification from facial images. *Computer Vision and Image Understanding*, 74(1), 1-21..

- [19] Liu, H., Zhou, P., & Tang, Y. (2016). Customizing clothing retrieval based on semantic attributes and learned features. <https://pdfs.semanticscholar.org/48c9/1983b51a1d443c11e46bbd5d38bc8b7c0f11.pdf>.
- [20] Liu, Q., & Peng, G. Z. (2010, March). A robust skin color based face detection algorithm. In *2010 2nd International Asia Conference on Informatics in Control, Automation and Robotics (CAR 2010)* (Vol. 2, pp. 525-528). IEEE.
- [21] Pang, J., Chen, K., Shi, J., Feng, H., Ouyang, W., & Lin, D. (2019). Libra r-cnn: Towards balanced learning for object detection. In *Proceedings of the IEEE Conference on Computer Vision and Pattern Recognition* (pp. 821-830).
- [22] Pokorny, P., Tennant, J. K., & Stevenson, P. E. (2013). Systems and methods for assessing exposure value of out of home advertising assets. *U.S. Patent Application No. 13/918,722*.
- [23] Quercia, D., Di Lorenzo, G., Calabrese, F., & Ratti, C. (2011). Mobile phones and outdoor advertising: measurable advertising. *IEEE Pervasive Computing*, 10(2), 28-36.
- [24] Ravi, S., & Wilson, S. (2010). Face detection with facial features and gender classification based on support vector machine. *International Journal of Imaging Science and Engineering*, 23-28.
- [25] Ravnik, R., & Solina, F. (2013). Audience measurement of digital signage: Quantitative study in real-world environment using computer vision. *Interacting with Computers*, 25(3), 218-228.
- [26] Rodner, E., Freytag, A., Bodesheim, P., Fröhlich, B., & Denzler, J. (2017). Large-scale gaussian process inference with generalized histogram intersection kernels for visual recognition tasks. *International Journal of Computer Vision*, 121(2), 253-280.
- [27] Roux, A., & Van der Walddt, D. (2014). Out-of-home advertising media: theoretical and industry perspectives. *Communitas*, 19, 95-115.
- [28] Roux, A. T., & Van der Walddt, D. I. R. (2016). Toward a model to enhance synergy of out-of-home advertising media integration strategies. *Journal of Promotion Management*, 22(3), 386-402.
- [29] Roux, T. (2014). The effectiveness of car advertising media: Perceptions of Generation-Y Consumers. *Mediterranean Journal of Social Sciences*, 5(20), 1877-1877.
- [30] Rowley, H. A., Baluja, S., & Kanade, T. (1998, June). Rotation invariant neural network-based face detection. In *Proceedings. 1998 IEEE Computer Society Conference on Computer Vision and Pattern Recognition (Cat. No. 98CB36231)* (pp. 38-44). IEEE.
- [31] Seo, Y., & Shin, K.-s. (2019). Hierarchical convolutional neural networks for fashion image classification. *Expert Systems with Applications*, 116, 328-339.
- [32] Yang, M.-H., Kriegman, D. J., & Ahuja, N. (2002). Detecting faces in images: A survey. *IEEE Transactions on Pattern Analysis and Machine Intelligence*, 24(1), 34-58.
- [33] Zhu, X., & Ramanan, D. (2012, June). Face detection, pose estimation, and landmark localization in the wild. In *2012 IEEE Conference on Computer Vision and Pattern Recognition* (pp. 2879-2886). IEEE.

Citizens' Adoption of Digital Technologies during COVID-19

(Work in Progress)

Thamer Alshammari*, Monash University, Australia and Saudi Electronic University, Saudi Arabia,
Thamer.Alshammari@monash.edu, T.Alshammari@seu.edu.sa

Chris Messom, Monash University, Australia, Christopher.Messom@monash.edu

Yen Cheung, Monash University, Australia, Yen.Cheung@monash.edu

ABSTRACT

The spread of Coronavirus disease 2019 (COVID-19) has affected both governments and businesses worldwide. Besides lives loss and disease, COVID-19 causes reduction in economic growth and increase in the unemployment rate, companies' bankruptcy, and the workload of healthcare. Governments and businesses have relied heavily on the digital technologies to eliminate or at least reduce the spread and effect of COVID-19. Therefore, individuals (as citizens requiring government services, employees working in either public or private sectors, or costumers having goods or services) were only able to accomplish their tasks through digital technologies. COVID-19 effect has implications on many research fields, including information systems. Prior studies that investigated the adoption of digital technologies have focused on technological, personal, and/or institutional factors. This work-in-progress paper attempts to explore the digital technologies adoption through the lens of COVID-19. This research uses the grounded theory. This work-in-progress paper presents research methodology and expected contributions.

Keywords: Coronavirus, COVID-19, pandemic, digital technologies, adoption, grounded theory.

*Corresponding author

INTRODUCTION

The first positive case of COVID-19 was reported by the local government in Wuhan City, China, in December 2019; since then, the virus has spread all over China and other 216 countries (WHO, 2020). On March 11, 2020, the World Health Organization (WHO) declared the new virus outbreak is a pandemic (WHO, 2020a). By October 21, 2020, about 40 million people have been infected by the virus, among them about 1.13 million died (WHO, 2020b).

There are several institutions working in developing vaccines for COVID-19. However, to date, there are no proven vaccines for COVID-19. Therefore, governments worldwide have taken precautionary actions to fight the spread of COVID-19. These actions include, but are not limited to lockdown and social distancing restrictions. Governments have also utilized technologies to limit the spread and effect of COVID-19. Many governments have transformed to online learning in order to continue the education process in a safe environment (Patricia, 2020). They also utilized social networks to increase their citizens' awareness on COVID-19 (Sahoo *et al.*, 2020). Moreover, some of the governments in the developed countries have also utilized advanced technology such as Artificial Intelligence, robotics and drones (Chamola *et al.*, 2020). Business have adopted some platforms to keep operating during the pandemic. Some examples of these technologies are business communication platforms to allow organization members arrange virtual meetings (e.g. Zoom, Microsoft Teams) and ticketing systems to solve employees' technical issues (e.g., Freshdesk).

Prior to the pandemic, the uptake of digital technologies by citizens is below expectations in developing and developed countries (Glyptis *et al.*, 2020). Which led many researchers to investigate the factors affecting the adoption of these technologies. The studies focused on identifying technological, personal, and/or institutional factors. Since then, many theories have been established for examples Theory of Planned Behavior (TPB) (Ajzen, 1991), Technology Acceptance Model (TAM) (Davis, 1989), and Technology–Organization–Environment Framework (TOE) (Tornatzky & Fleischer, 1990). However, as Venable (2013) states existing theories rely on the state of the world (or context). Therefore, due to change in the state of the world as well as social and individuals' behaviors because of COVID-19 existing theories cannot comprehend digital technologies adoption during COVID-19.

Scholars expect that similar pandemic are expected to breakout every few years (Ahmadi *et al.*, 2020; Cranford, 2020). This makes pandemics a reoccurring issue, which need to be prepared for at every level. Understanding the digital technologies adoption during COVID-19 can help governments in the future during similar potential pandemics.

In this study, we attempt to investigate the adoption of digital technologies through the lens of COVID-19. This study does not intend to replicate prior studies rather it concerns with investigating the adoption of digital technologies through the lens of COVID-19 effects. This study will use the grounded theory to overcome the limitations of aforementioned theories.

RESEARCH BACKGROUND

COVID-19

COVID-19 have many symptoms such as fever, tiredness, and shortness of breath. It also has less common symptoms such as sneezing, loss of appetite, and sore throat (Blumfield *et al.*, 2020). In extreme cases infected people can have kidney failure (Blumfield *et al.*, 2020). COVID-19 is a deadly disease, about 2.7% of the infected people died (WHO, 2020b).

COVID-19 like other viruses spread between people through the air (Nakamura & Managi, 2020). They also live in air and on surfaces for a period of time that has not been confirmed yet, but some scholars estimate that they can live outside human bodies for up to 28 days depending on the nature of the surface (Ari, 2020). The most dangerous fact about COVID-19 is that its symptoms do not show as soon as the body gets infected (Ari, 2020). Therefore, infected people may spread the virus to others without knowing.

Fighting COVID-19

To date, there are no proven vaccines for COVID-19. Therefore, governments worldwide have issued instructions to fight the spread of COVID-19. These instructions included but are not limited to wearing masks in public places, prohibiting social gathering, closing shopping centres, and imposing curfews. Moreover, governments have started issuing fines to business and individuals breaking the precautionary instructions.

Beside the aforementioned precautionary instructions, governments worldwide have transformed to relying on Information Communication technologies (ICTs). For example in the field of education many schools and universities have adopted online learning to avoid large gatherings in classrooms, which can spread COVID-19. Nowadays, patients do not have to go to hospitals to meet doctors, which might increase the chance of being infected by COVID-19. Governments have provided what is known as telehealth, which is a service that allows patients meet general practitioners and specialists via advanced communication technologies (Smith *et al.*, 2020). Governments have also been relying on social networking sites (e.g. Twitter and Facebook) to increase their citizens' awareness of COVID-19 and provide up-to-date statistics on the number of infected and recovered cases (Sahoo *et al.*, 2020).

Besides government, businesses have also heavily relied on digital technologies to continue operating during the pandemic. Traditional stores have transformed to adopted electronic commerce after closing their stores. Moreover, technology based businesses offering cloud computing services such as Microsoft have thrived during the pandemic due to increase in demand by governments and businesses (Gadgets, 2020).

However, due to the low level of utilization of digital technologies by citizens, governments might not benefit from implementing such technologies (Alshammari *et al.*, 2019; Glyptis *et al.*, 2020). The following section reviews the adoption of digital technologies.

Adoption of ICTs

Over the past few decades, several theories and models have been established to investigate the adoption of new information technologies. These models have focused on specific aspects, which differ from one model to another. For instance, TAM focuses on perceived usefulness and perceived ease of use; whereas, TPB focuses on attitude, subjective norm, and perceived behavioral control. Table 1 presents each model with its factors and an example of a study that employed the model to investigate the adoption of ICTs.

Table 1: Most common models, their factors and citation of studies adapted these models.

Model	Factors	Studies
TRA	Attitude, Subjective norm	(Althunibat & Sahari, 2011)
TPB	Attitude, Subjective norm, Perceived behavioral control	(Susanto & Goodwin, 2013)
TAM	Perceived usefulness, Perceived ease of use	(Almarashdeh & Alsmadi, 2017)
DOI	Relative advantage, Compatibility, Complexity, Trialability, Observability	(Abdelghaffar & Magdy, 2012)
UTAUT	Performance expectancy, Efforts expectancy, Social influence, Facilitating conditions	(Baabdullah <i>et al.</i> , 2017)

These theories were proven to successfully determine the factors affecting the adoption of information technologies during normal times. However, during the COVID-19 pandemic none of these models is suitable for studies attempting to explore a new context (e.g. the COVID-19 pandemic). The following section reviews the literature to find the most suitable theory for exploring the adoption of digital technologies during COVID-19.

Adoption of ICTs during COVID-19

The aforementioned (traditional) theories were employed and successfully explained the adoption of digital technologies. However, as Venable (2013) states theories appropriateness cannot be timeless as it depends upon the state of the context, which is currently changing because of COVID-19. The current situation is creating unprecedented circumstances that increase

the need to explore the adoption of information technologies through the lens of COVID-19. Because this situation is relatively new, very little is known, and there is no enough data, it is recommended to adopt the Grounded Theory (GT) (Goulding, 1998). The following section reviews the literature on the GT.

Grounded theory

The GT has been developed by Glasser and Strauss (1967). According to Strauss (1987), the GT is not a specific method rather it is a guideline of conducting qualitative analysis. The GT has evolved in practice due to scholars' attempts to elaborate on the procedures in some detail (Corbin & Strauss, 1990). The GT has been used in several research fields including the information systems field. The GT can be defined as a tool for developing theories from data systematically collected and rigorously analysed (Goulding, 1998). According to Charmaz (2006), the GT is a set of practical rules to plan for data collection and analysis to develop a theory form data. The GT is used when there are no existing theories or limited theories, i.e. little is known, regarding the phenomenon that is of interest (Alemu *et al.*, 2012). Table 2 summarizes sample studies that have used the grounded theory.

Table 2: Examples of studies that have adopted GT.

Context	Summary	Reference
E-government	This study adopted the GT to explore the factors affecting the adoption of E-government in China	(Liang <i>et al.</i> , 2017)
E-learning	This study adopted the GT to explore the opportunities to utilize e-learning in medical education.	(Chu <i>et al.</i> , 2020)
E-commerce	This study adopted the GT to investigate the aspects that affect the adoption of e-commerce from consumers' perceptive.	(Alqahtani <i>et al.</i> , 2012)

RESEARCH METHODOLOGY

This will explore the adoption of digital technologies through the lens of COVID-19 by adoption the qualitative GT. The GT is deemed appropriate for this research as COVID-19 pandemic is changing the state to the world. Semi-structured interviews will be conducted with 20 with experts in the information systems field. The GT consists of data collection and analysis. The following Table 3 explains the analysis terminologies of the GT.

Table 3: Explanations of the analysis terminology of the GT.

Term	Explanation
Open coding	Means examining the data line by line to create categories (Goulding, 1999; Corbin & Strauss, 1990).
Axial coding	Means merging the codes based on the relationship between subcategories and the respective categories (Sarker, 2000; Corbin & Strauss, 1990).
Selective coding	Means selecting the core category and its related categories (Draucker <i>et al.</i> , 2007; Corbin & Strauss, 1990; Strauss, 1987).
Concepts	Means having codes on similar contents grouped into collections (Müller & Olbrich, 2012).
Categories	Means groups of similar codes used as the base of the theory (Müller & Olbrich, 2012; Strauss, 1987).

During the analysis NVivo software will be used as it is considered to be the best tool for coding qualitative data (Hilal & Alabri, 2013).

EXPECTED CONTRIBUTIONS

The research attempts to extend extant literature by offering timely and relevant insights on digital technologies adoption during COVID-19. It is expected that the findings will bring to light novel aspects that can be used to examine the adoption of new technologies during the pandemic. This study does not intend to replicate prior studies rather it concerns with investigating the adoption of digital technologies through the lens of COVID-19 effects. In order to achieve this aim the GT will be used as it has been proven to be the most suitable for this type of research, where little is known about the phenomenon. This will helps researchers and practitioners to better understand the adoption of the technologies during the pandemic. It is expected that the findings (e.g. novel aspects affecting the adoption of ICTs during pandemics) will open the gate for future studies in the IS field. Moreover, it will help policy makers to gain deeper insights on the adoption of ICTs during the pandemic and therefore, utilize ICTs to fight COVID-19

REFERENCES

- [1] Ahmadi, M., Sharifi, A., Dorosti, S., Ghouschi, S. J., & Ghanbari, N. (2020). Investigation of effective climatology parameters on COVID-19 outbreak in Iran. *Science of the Total Environment*, 729, 138705.
- [2] Ajzen, I. (1991). The theory of planned behavior. *Organizational Behavior and Human Decision Processes*, 50(2), 179-211.
- [3] Alemu, G., Stevens, B., & Ross, P. (2012). Towards a conceptual framework for user-driven semantic metadata

- interoperability in digital libraries. *New Library World*, 113(1/2), 38-54.
- [4] Alshammari, T., Messom, C., & Cheung, Y. (2019). Factors Affecting Continuance Intention of Mobile Government Services. In *19th International Conference on Electronic Business*, 520-525.
- [5] Ari, A. (2020). Practical strategies for a safe and effective delivery of aerosolized medications to patients with COVID-19. *Respiratory Medicine*, 167, 105987.
- [6] Blumfield, E., & Levin, T. L. (2020). COVID-19 in pediatric patients: a case series from the Bronx, NY. *Pediatric Radiology*, 50(10), 1369-1374.
- [7] Chamola, V., Hassija, V., Gupta, V., & Guizani, M. (2020). A Comprehensive Review of the COVID-19 pandemic and the role of IoT, drones, AI, blockchain, and 5G in managing its impact. *IEEE Access*, 8, 90225-90265.
- [8] Chu, A., Biancarelli, D., Drainoni, M. L., Liu, J. H., Schneider, J. I., Sullivan, R., & Sheng, A. Y. (2020). Usability of Learning Moment: Features of an E-learning Tool That Maximize Adoption by Students. *Western Journal of Emergency Medicine*, 21(1), 78-.
- [9] Corbin, J. M., & Strauss, A. (1990). Grounded theory research: Procedures, canons, and evaluative criteria. *Qualitative Sociology*, 13(1), 3-21.
- [10] Cranford, S. W. (2020). I may not have symptoms, but COVID-19 is a huge headache. *Matter*, 2(5), 1068-1071. doi:doi.org/10.1016/j.matt.2020.03.017.
- [11] Davis, F. D. (1989). Perceived usefulness, perceived ease of use, and user acceptance of information technology. *MIS Quarterly*, 13(3), 319-340.
- [12] Gadgets. (2020). *Microsoft Earnings Continue to Soar Due to Increased Demand for Cloud*. Retrieved from shorturl.at/kqCG2
- [13] Glaser, B. G., & Strauss, A. L. (1967). *The Discovery of Grounded theory: Strategies For Qualitative Research*. NJ: USA: Transaction Publisher.
- [14] Glyptis, L., Christofi, M., Vrontis, D., Del Giudice, M., Dimitriou, S., & Michael, P. (2020). E-Government implementation challenges in small countries: The project manager's perspective. *Technological Forecasting and Social Change*, 152, 119880.
- [15] Goulding, C. (1998). Grounded theory: The missing methodology on the interpretivist agenda. *Qualitative Market Research*, 1(1), 50-57.
- [16] Goulding, C. (1999). Grounded Theory: some reflections on paradigm, procedures and misconceptions. Working Paper Series, WP006/99, ISSN Number ISSN 1363-6839
- [17] Hilal, A. H., & Alabri, S. S. (2013). Using NVivo for data analysis in qualitative research. *International Interdisciplinary Journal of Education*, 2(2), 181-186.
- [18] Lee, C., & Wan, G. (2010). Including subjective norm and technology trust in the technology acceptance model: a case of e-ticketing in China. *ACM SIGMIS Database: the DATABASE for Advances in Information Systems*, 41(4), 40-51.
- [19] Liang, Y., Qi, G., Wei, K., & Chen, J. (2017). Exploring the determinant and influence mechanism of e-Government cloud adoption in government agencies in China. *Government Information Quarterly*, 34(3), 481-495.
- [20] Müller, B., & Olbrich, S. (2012). Developing theories in information systems research: the grounded theory method applied. In *Information Systems Theory* (pp. 323-347). Springer, New York, NY.
- [21] Nakamura, H., & Managi, S. (2020). Airport risk of importation and exportation of the COVID-19 pandemic. *Transport Policy*, 96, 40-47.
- [22] Patricia, A. (2020). College students' use and acceptance of emergency online learning due to Covid-19. *International Journal of Educational Research Open*, 1, 100011.
- [23] Sahoo, S., Rani, S., Parveen, S., Singh, A.P., Mehra, A., Chakrabarti, S., Grover, S., & Tandup, C. (2020). Self-harm and COVID-19 Pandemic: An emerging concern—A report of 2 cases from India. *Asian Journal of Psychiatry*, 51: 102104.
- [24] Sarker, S., Lau, F., & Sahay, S. (2000). Using an adapted grounded theory approach for inductive theory building about virtual team development. *ACM SIGMIS Database: the DATABASE for Advances in Information Systems*, 32(1), 38-56.
- [25] Smith, A. C., Thomas, E., Snoswell, C. L., Haydon, H., Mehrotra, A., Clemensen, J., & Caffery, L. J. (2020). Telehealth for global emergencies: Implications for coronavirus disease 2019 (COVID-19). *Journal of Telemedicine and Telecare*, 26(5), 309-313.
- [26] Strauss, A. L. (1987). *Qualitative Analysis for Social Scientists*. Cambridge university press.
- [27] Tornatzky, L. G., Fleischer, M., & Chakrabarti, A. K. (1990). *Processes of Technological Innovation*. Lexington books.
- [28] Venable, J. R. (2013, June). Rethinking design theory in information systems. In *International Conference on Design Science Research in Information Systems* (pp. 136-149). Springer, Berlin, Heidelberg.
- [29] WHO (2020). *Novel Coronavirus (2019-Ncov) situation report - 1*. Geneva, Switzerland. Retrieved from <https://www.who.int/docs/default-source/coronaviruse/situation-reports/20200121-sitrep-1-2019-ncov.pdf> (01/10/2020).
- [30] WHO. (2020b). *Coronavirus Disease (COVID-19) Dashboard*. Retrieved from <http://covid19.who.int>
- [31] WHO. (2020b). *Timeline: WHO's COVID-19 Response*. Geneva, Switzerland. Retrieved from <http://www.who.int/emergencies/diseases/novel-coronavirus-2019/interactive-timeline#!> (01/10/2020)

Constructing National Identity Education through Online Platform: A Case Study of Discovery Education for Primary Schools in UK

(Work in Progress)

Erhui Shao, Chongqing Normal University, China, 295712987@qq.com
Honglei Li*, Northumbria University, UK, honglei.li@northumbria.ac.uk

ABSTRACT

Through content analysis of Discovery Education, we found that the content of national identity is abundantly embodied in the curriculum of primary schools in UK. As a widely used online platform in primary schools of UK, Discovery Education integrates the content of national identity education into the curriculum. The presentation meets the needs of primary school students for its psychological and behavioral characteristics and provides personalized learning opportunities through a variety of links. Such practice displays advantages of online education. Recommendations are offered to developing virtual learning community, data analysis of online teaching process and the construction of expression system of online national identity education.

Keywords: Primary schools in UK, online education, national identity education.

*Corresponding author

INTRODUCTION

National identity originates from the identity and acceptance of the individual to the country. From the perspective of nation, national identity is concerned with the internal cohesion which influences and determines whether a country can maintain relative stability in the multicultural collision. From the perspective of the individual, it affects individual's self-unity and sense of belonging, and it is the psychological support for individual to adapt to the social development.

In the past decades, national identity has been a focus for researchers. According the literature review, some researchers focused on the key elements of national identity such as language identity, cultural identity, historical identity, institutional identity, and so on. Some researchers paid attention to how the sense of national identity develops during the course of adolescence and found that the importance which children attribute to their national identity increases significantly between 5 and 11 years of age. Some other researches also provided insights about when it is appropriate to teach children to think about issues of diversity and nationality, and has implications for curriculum and policy related to national identity education in multicultural nations. These studies provide the basis for this paper.

RESEARCH METHODOLOGY

Case Study is chosen as the main method of this paper and Discovery Education as the research object. In 2020, the online curriculum of primary schools in UK played an important role due to the COVID-19, especially the online Education platform provided by the OAK National Academy, BBC, Discovery Education, etc.

The features of Discovery Education

The recourses can be viewed repeatedly and it covers all subjects (including English, Maths, History, Geography, Art, PE, PSHE and so on) and all ages form foundation to Key stage 1 and Key stage 2 of primary school, it is highly relevant to the content of the face-to-face courses offered by primary schools in UK so it can complement the curriculum in school through providing many kinds of resources such as videos, picture books, images, quick links (news, games and so on)

Content Analysis

Content analysis are employed to deal with the resources. Through classification of curriculum content and identification of themes and key words, features and trends are pinpointed.

FINDINGS

The curriculum system of primary schools in UK is rich in the content of national identity education, which is mainly reflected in English, history, geography, PSHE and so on. There are higher requirements for the selection and design of curriculum resources, curriculum content, information dissemination and so on for online education achieving good results in a time-and-space-separated situation. National identity education through online platform has higher requirements for technical support and discourse expression. The curriculum resources provided by Discovery Education are varied and integrates the content of national identity education into various courses, uses narrative methods that match the attention and memory characteristics of primary school students, and provides a large number of in-depth links to students to expand the content of national identity education through online platform.

Decentralization and Integration: national identity education is embodied in the curriculum system

There is no special national identity curriculum in the UK, but many courses in its curriculum system contain a variety of national identity education. According to the curriculum resources provided by Discovery Education, national identity education is embodied in English (especially reading material in English courses), PSHE (Personal, Social, Health and Economic Education), History and Geography. According to the content classification of national identity education, these courses contain a great deal of content related to the cultural customs, social institution, significant historical events, geographical boundaries of the country etc. It helps primary school students to construct the thinking mode, value orientation and behavior habit that accord with the mainstream society through the study of these contents, and then forms the individual cognition of the country and the nation.

The emphasis and presentation form of national identity education are different in different courses. In English class, the main form is the way of thinking identity. primary schools of UK pay great attention to the cultivation of students' reading ability all along. Reading is an extremely significant part in both online and face-to-face class. In addition to intensive reading of relevant literature in English classes under the guidance of teachers, the school will also provide a large number of extra-curricular books for students to expand their reading. These reading materials mainly include classic works of local writers and stories with traditional cultural characteristics. Most of the reading materials on Discovery Education are written by native British writers who were born and have lived in UK for a long time.

Take J.K. Rowling for example, she was born in Gwent County, England. Her *Harry Potter* series are full of British elements; There are also tales of traditional cultures such as *Merlin and The Dragons* and *The Loch Ness Monster*, and so on. From the perspective of values education, through the analysis and intensive reading of these reading materials, primary school students learn to identify different types of characters and make value judgments, and gradually form the value orientation accepted by the whole society. From the perspective of group psychology, through reading training, pupils learn to infer the feelings, the thoughts and the psychology of characters from their behavior, also learn to recognize and discuss various themes and customs in writing. The cultural customs contained in the traditional stories are infused into the students' cognitive system in the process, building a bridge between the nation's collective subconscious and its actual behavior, so that students can generate and even build up the mainstream of social thinking.

In the course of history, the primary school students initially formed their emotional identification with the history of the country by studying the significant events and the lives of the important persons who promoted the development of history in UK. In the course of geography, students gradually build and strengthen the individual identity of the territory with the study of the geographic information of the community and the city. And cultural and institutional identity education are the main contents in PSHE course, primary school students form a basic understanding of cultural customs and their historical inheritance from the perceptual level through the popularization of knowledge about festivals and celebrations, understand their own national system through the rules and institutions of social operation, lay the psychological foundation of national identity.

Table 1: Curriculum Distribution of National Identity Education

Curriculum	English	History	Geography	PSHE
Main content	Education in way of thinking identity: mainly through the reading and analysis of literary works and news materials in UK	Education in history identity: Mainly through significant historical events and important historical figures in UK	Education in territory identity: mainly on the map, mountains and rivers, well-known adventure course in UK	Education in cultural and institutional identity: festival celebrations, rules and institutions in UK
Example	J.K. Rowling (KEYSTAGE 2, English)	Second World War (KEYSTAGE 2, History)	Maps and Mapping (KEYSTAGE 2, Geography)	Democracy & Elections (KEYSTAGE 2, PSHE)

3.2. Convergence and Confirmation: multiple teaching materials are used in the same subject to reinforce identity.

Convergence generally refers to the process in which related things come together around a core. Convergence of information is more common on web, where the relevant information easily comes together and, in some cases, mutually reinforcing with each other. An individual's memory is related not only to the intensity of the information received, but also to the number of repetitions of the information received. Moreover, the same content presented in different forms can stimulate different parts of the brain to react and form a comprehensive understanding of the information which help the information to enter individual's

long-term memory system. The curriculum of Discovery Education reflects this feature of convergence and confirmation with videos, books and links related to each other, presented in different ways around the same theme. The most striking feature of Discovery Education's course resources is their brevity. Each course presented in different forms around the same core topic typically consists of one or more five-minute videos, one or more 10-page picture books, and a handful of small exercises. These contents arouse primary school students' interest and trigger their perceptual knowledge through video and pictures. Some contents can be transformed into rational knowledge through picture book reading, and then the learning content and activities are mutually converged through the after-class practice, thus a complete cognitive process including perceptual knowledge and rational knowledge and experience which makes relevant knowledge enters the student's cognitive system.

Take <Black History Month> of PSHE in KEY STAGE 2 for example. Firstly, the theme contains four categories (14 in all) of videos, the videos are on equal rights protests and social progress on black rights and individuals contributing to social progress and related news report. Secondly, knowledge development including prominent black representatives in various fields and images about significant people or classical scenes is related to equal rights. Thirdly, some printable resources are accessible for students.

Table 2: The Sample of Cultural Identity Education

Topic : Cultural Identity Education	videos	Protest (The story of Rosa Parks\The Little Rock Nine\The Berlin Olympic Games, 1936\Taking a knee protest) Progress (Britain elects the most diverse Parliament ever\The story of the Empire Windrush\President Barack Obama leaves office) People (The story of Mary Seacole\The life of Nelson Mandela\The life of Muhammad Ali) News reel (Martin Luther King marches for civil rights\Mandela walks to freedom\ Arrival on the Empire Windrush\Barack Obama is elected President\Black History Month)
	Facilitates	Early black British history, Trailblazers, World leaders, Cultural icons, Sporting heroes, Civil Rights in the USA, Historic speeches
	Printable Resources	To view these resources, you will need Adobe Acrobat.
	Images	Katherine Johnson at her desk – 1966, Katherine Johnson receives the Presidential Medal of Freedom – 2015, Martin Luther King, Jr., The Rev. Dr. Martin Luther King Jr., Nelson Mandela in prison, Nelson and Winnie Mandela – 1990, Rosa Parks being fingerprinted by a police officer – 1958, Rosa Parks – 1999 (Totally 57 pieces)

Key-Point Narration: Telling History through Significant Events and important characters

Individuals of different ages have different psychological states and learning abilities, therefore, it is necessary to carry out education according to the individual's psychological development in order to achieve good results. From the perspective of attention depth, primary school students tend to be attracted by something new and changing, and they are not good at learning systematic and abstract knowledge; In terms of the stability of attention, it is difficult for primary school students to maintain a high concentration of attention for a long time. Judging by the propensity of attention, primary school students have strong emotion in the process of perceiving something, and they generally complete the reception of information based on their own interests. Therefore, the teaching content for primary school students should be able to grasp their attention, and achieve educational goals in line with their psychological and behavioral characteristics.

Key-Point narration used by Discovery Education can catch students' attention quickly through vivid and interesting points, and it can also stimulate students' interest in autonomous learning through a series of points. Systematic learning of history is necessary for primary school students but it is a little boring for them, and significant events are relatively easy to grab their attention and then enter their memory system. Discovery Education has chosen different types of points for its historical narrative such as through the major events that have taken place and important figures to promote the historical process, which can help primary school students form a preliminary understanding of history, evoking a collective sense of history through the national remembrance holidays, learning about national culture and historical heritage through holiday celebrations.

Table 3: Significant Events and Persons, Festivals, Days of Commemoration

Significant events	Second World War, 21st Century Timeline (Find out about significant people and events from the recent past by exploring an interactive timeline, which is organised around themes.)
Day of Commemoration	VE Day (Victory in Europe Day)
Festival	Red Nose Day
Significant persons	Florence Nightingale and Mary Seacole Round the World with Captain Cook

Link Extension: Providing the Possibility of Personalized Learning and Deep Learning

The development of online education has provided greater possibilities for personalized learning for primary school students, whose students learning needs are varied and are in flux. In the traditional teaching process, teachers can only take the needs of the majority into consideration, so the depth and breadth of teaching content can only be kept at an average level, which makes them difficult to carry out personalized learning. On the contrary, online platform can expand the depth and breadth of learning through various links which can be chosen by students according to their own interests and abilities. At the same time, teachers can seize the static model (such as learning style, cognitive characteristics) and the dynamic model (the change of the interaction between the learning process and the environment) by mining the relevant educational data in the teaching process to optimize the curriculum resources on the basis of grasping the students' learning model.

In addition to the core content of the course, Discovery Education offers a number of links to articles, videos and a series of photos, as well as a number of links of websites. If students have a strong interest in the specific topic, they can click on these links step by step to expand and deepen their knowledge. Taking J.K. Rowling as an example, the online platform provides the core content of the Harry Potter series such as the main characters and classic scenes, it also provides main readers and news reports and the author's life and pictures and reading comments of Harry Potter series and so on. These diversified types of links meet the personalized needs of different students with differentiated interests and abilities.

Table 4: Links of *Harry Potter*

Videos	<p>Harry Potter books The readers\Entering the wizard world</p> <p>The characters Favourite characters\ Harry's school Hogwarts\Quidditch</p>
News archive	<p>News archive: A collection of news videos (12) and articles (10) about J.K. Rowling and the <i>Harry Potter</i> books.</p>
Factfiles	<p>J.K. Rowling: Find out about the author.</p> <p>The books: Learn what happens in each of the seven books.</p> <p>The characters: Find out about the most popular characters in the series.</p> <p>Hogwarts: Learn about the famous wizarding school.</p> <p>Quidditch: Could you be a future Quidditch star?</p>
Things to do	<p>Each resource can be used on-screen with type-in text boxes. Alternatively, they can be printed out and used away from a computer.</p> <p>Story openings: Using different openings for stories, in order to gain the reader's interest.</p> <p>Character description: Looking at and creating detailed descriptions of characters within stories.</p> <p>Ideas for longer pieces of writing: Suggestions for longer pieces of writing, some of which involve children working in pairs.</p>
Photos	<p>Photo gallery A collection of photographs of J.K. Rowling and the <i>Harry Potter</i> books.</p>
Book reviews	<p>An opportunity for pupils to read comments from other children about J.K. Rowling's books and to submit their own.</p> <p>J.K. Rowling Book reviews</p>

DISCUSSION AND SUGGETION

Make the most of online education in national identity education

In terms of the perspective of technological change, online education provides a more convenient channel for connecting educators and learners which can help communicating and disseminating information across the space-time barrier. In terms of knowledge dissemination, it is more convenient to share high-quality educational resources and enrich teaching process with various types of curriculum resources by the support of technology. In terms of the perspective of national identity education, in addition to the changes in educational and teaching methods brought about by technological changes, online education which has profound advantages should play a more active role in national identity education.

Firstly, the way of thinking emerges a fundamental shift in in online education. How to express, stimulate interest and motivation are the key issues that must be considered in online national identity education. The traditional national identity education can be carried out in the way of activities and projects, and the effect of identity education can be strengthened by immersion experience. In contrast, online national identity education has its own unique advantages. However, if we want to achieve good results, we need to study not only the technology, but also the interactive process under the support of technology, stimulating students' sustained interest in learning by exploring the discourse system suitable for online national education, and setting key nodes in the learning process.

Secondly, online education provides an effective opportunity for personalized learning. Online platform can not only provide abundant curriculum resources, but also expand the depth and breadth of some knowledge points through various links which

provides more possibilities for students' personalized learning. Students can achieve deep learning according to their own interests and abilities, of course, this also puts forward higher requirements and expectations for online education, it is urgent to solve the problems of arousing students' attention and interest and stimulating students' persistent motivation.

Focusing on the role of virtual communities in online national identity education

Differing from traditional face-to-face teaching, an even greater challenge for online education is how to stimulate students' interest and sustain motivation in the context of time-and-space separation. In other words, students can only rely on complete self-discipline because of the teachers' "absence" in online education, which brings great uncertainty to the process and effect of learning. At the same time, due to the barrier of space-time, learners of online education can only participate in the learning process in an individualized way, this kind of lonely learning mode will not only have a negative impact on the learning process such as learning interruption, etc., and also fails to exert the positive interactive influence among the educational objects. The separation of time and space between teachers, students and students, coupled with the difficulty of effective communication and interaction, students often find it hard to maintain the long-term and continuous learning because of emotional loss, loss of motivation and other difficulties, even show a low-input shallow learning state. Therefore, some online platforms will need to build a communication platform by establishing a virtual community to meet the intrinsic needs of mutual stimulation and communication in the learning process.

Paying more attention to the data analysis of online national identity education

Compared with traditional face-to-face courses teaching, one of the outstanding advantages of online national identity education is that it can be easy to grasp the static model and dynamic model of student learning process. Different with other courses in learning and evaluation, it is difficult to measure the effect of national identity education which cannot rely entirely on examinations or other similar means. Therefore, it is a difficult problem to take hold of the learning effect of students objectively and comprehensively. But online national identity education can be an effective measure of learning outcomes, to a certain extent. Students will have different learning preferences, click frequency, interactive style or attitude towards some issues in the process of online teaching, these characteristics can be more objectively reflected through the data. we can understand the deficiencies of the learning content and make timely adjustments through the analysis of some key data, on the other hand, we can also understand students more accurately and target to enhance the effectiveness of online education in a comprehensive grasp of the psychological and behavioral characteristics of students.

REFERENCES

- [1] Koh, S. S. (2010). *National identity and young children: A comparative study of 4th and 5th graders in Singapore and the United States* (Doctoral dissertation). Available from ProQuest Dissertations & Theses database, (UMI No. 3441678), University of Michigan.
- [2] Tormey, R. (2006). The construction of national identity through primary school history: The Irish case. *British Journal of Sociology of Education*, 27(3), 311-324.
- [3] Waldron, F., & Pike, S. (2006). What does it mean to be Irish? Children's construction of national identity. *Irish Educational Studies*, 25(2), 231-251.
- [4] Barrett, M (2000) *The development of national identity in childhood and adolescence*. Inaugural lecture presented at the University of Surrey.
- [5] Idris, F., Hassan, Z., Ya'acob, A., Gill, S. K., & Awal, N. A. M. (2012). The role of education in shaping youth's national identity. *Procedia-Social and Behavioral Sciences*, 59, 443-450.

R&D Investment that enhances IT Firm Survival

(Work in Progress)

Buraj Patrakosol*, Chulalongkorn University, Thailand, buraj@cbs.chula.ac.th

ABSTRACT

IT industry is a research-intensive industry. IT firms focus on advanced research activities to stay relevant. Their survival depends on value creations from innovations based on the research. Source of fund to these innovation-related activities are commonly expressed in terms of R&D investment. However, this investment is not the direct indicator of innovation outcome, which impacts firm's survival. This is the gap between R&D investment and survivability of the firm. To narrow the gap, innovation process and value creation have been focuses of firm's innovation literature. The literature has narrowed the gap, but uncertainty still largely exists. Both researchers and practitioners often classified R&D investment as a risky investment. This study continues this line of conversation and offers empirical evidence suggesting that R&D investment could be risk mitigator rather than risk enhancer. Data of 2,087 firm-years in IT industry revealed that successful IT firms may invest in R&D to mitigate innovation-related competitive risks. When risk is under control, survivability of the firm increases. IT firm should, therefore, prioritize R&D investment for innovations and products that mitigate competitive risks. This insight is particularly relevant to post CoVID-19 pandemic world because the survival of IT firms depends on how they perceive risks associated with the new-normal world and how they innovate to mitigate those risks.

Keywords: IT industry, R&D investment, Competitive risk mitigation.

*Corresponding author

INTRODUCTION

Research-intensive industry such as IT industry is characterized by high environmental uncertainty and innovation complexity. Firms in IT industry focus on delivering cutting-edge innovations to stay on the competition. Innovation-related competitive risk is fundamental to IT firms' survival. Mitigating this risk becomes a common aspiration among IT firms. The worldwide CoVID-19 pandemic will likely to heighten environmental uncertainty and accelerate the need for complex innovation. Therefore, IT firms must pay even more attention to innovation-related competitive risk.

Research and development (R&D) investment can be used as a tool to mitigate the risk. Interestingly, the investment does not directly suggest innovation outcomes. Researchers and practitioners largely classified R&D investment as a risky investment because the return on investment often mismatch the cost of investment (Xin & Choudhary, 2019). Yet, research-intensive firms are aggressively investing in R&D because R&D investments generally have positive effect on firms' performance (Kuo, Wu, & Lin, 2019).

Given the intensity and the general effects of R&D investment, several IT firms did not survive the competition. One may argue that failures of these firms could be function of risks introduced by R&D investments. Other may suggest that factors are numerous related to firm's demise including but not limited to strategic misdirection, disruption by certain technology, or internal mismanagement. This study seeks to clarify the linkage, if there is any, between R&D investment behavior and firm survival. Therefore, the first research question is posted.

RQ1: Is general R&D investment behavior significantly contribute to IT firm survival?

Like others, IT firms are facing uncertainties. These uncertainties present risks to the firms. Innovation-related competitive risk is among uncertainties that may adversely affect future of any IT firm. R&D investment could be a tool to mitigate this risk. However, the investment may introduce additional risks to the firm because successful innovation is ex post phenomenon. Innovation is invented and is exploited by the firm. Then, success of the exploitation could be materialized. These arguments present dilemma to the management team regarding the R&D investment. This study aims to understand relationships between R&D investment and innovation-related competitive risk in the context of firm's survivability. This discussion points to the second research question.

RQ2: How do innovation-related competitive risks contribute to R&D investment behavior in the context of survived and of not-survived IT firms?

Two research questions are posted. This study proceeds with hypothesis building, data collection, and hypothesis testing respectively. Finally, it reports findings and makes a conclusion to the research questions.

HYPOTHESIS BUILDING

This study formulates hypothesis to address RQ1 by reviewing literature and connecting dots between R&D investment and firm survival. The literature suggests a chain of events below.

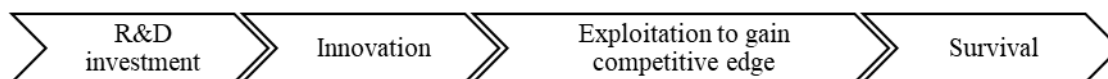

Investment R&D commonly initiates by top management. Custódio, Ferreira, & Matos (2019) discover certain top executive can lead firm to higher innovation outputs. One reason for their successes is their skill to balance risk and opportunity across R&D initiatives. However, having more innovations does not directly connect to firm's survival. Case-study in highly innovative firms by Urbinati *et al.* (2019) highlights the importance of opportunity recognition and product value creation connecting innovation to survival. Even then, to survive the competitive is still not an easy mission. Opportunity in the market itself can be a source of firm's misfortune. Khanagha *et al.* (2018) reveals that innovation-to-market process in technology-driven firm is complex with multi-dimensions and potentially conflicting priorities. Market demand heterogeneity is the source of this complexity. Firm counters this heterogeneity by modifying innovation process to accommodate variety of technological advances. However, this modification causes unintended consequence. Firm's product portfolio is weakened because innovations are simultaneously pushed forward in multiple directions. As a result, firm cannot sustain competition under high market heterogeneity.

Given this chain of events, the failure of decision-maker at any point cannot be known *ex ante*. Executive may successfully encourage a wide range of innovations but few of them were commercially viable. Hence, failure of a firm cannot be predicted *ex ante* by R&D investment decision. Failure to R&D investment is *ex post*. This study expects not-survived firms to behave during their "alive" periods very similar to their survived counterparts. Taking current discussion and RQ1 into account, H1 is proposed.

H1: R&D investment behavior is similar between survived and not-survived IT firms.

Based on RQ2, this study recognizes differences between survived and not-survived states of firms and proposes two hypotheses for each state. Competitive risk is not having access to critical resources to satisfy competitive requirements (George, Wiklund, & Zahra, 2005). Therefore, innovation-related competitive risk is the missing of essential innovations to sustain firm's competitiveness. When risk is severe, its effect can be devastated to the firm. Consistently exposed to severe competitive risks is the threat to firm survival. In context of this study, IT firm failed to delivery competitive values from innovations for a period may not survive. Risk mitigation is to prepare organization for potential threats. This study makes distinction between R&D project risk mitigation and competitive risk mitigation based on R&D investment. The former is to enhance success rate of the project. This type of mitigation, however, does not directly mitigate competitive risk (Calof & Smith, 2010). The latter is to enhance survivability of the firm. Executives in high technology firms are better incentivized to undertake risk mitigation executions rather than to exercise risk aversions (Makri, Lane, & Gomez-Mejia, 2006). Absent of risk taking hinders firm's performance. While moderate risk taking enhances the performance. If R&D investment were the risk mitigation mechanism for survived firms, observed innovation-related risks should positively correlate with R&D investment. The more risks are observed, the better the risk mitigation can be initiated by executive. Therefore, survived firm's executives increase the firm's R&D investment. Hypothesis 2a is proposed.

H2a: Innovation-related competitive risks positively affect R&D investment behavior in survived IT firms.

R&D is an important part of innovation process. Investment in R&D creates core innovation capability. According to Péreza *et al.* (2019), this capability creates positive feedback loop for greater innovations in successful firms but produces no effect for unsuccessful firms. A reason of the ineffectiveness is 'competency trap'. Levitt and March (1988) notes that this trap is when firm keeps doing the same activities, experiencing diminishing returns of its performance. R&D activity is carried out, but it does not produce desired outcomes. R&D investment indirectly measures innovation. It provides input to innovation activities but is not direct indicator of innovation outcome. Nonetheless, R&D investment can be interpreted as firm's willingness to innovate (Dziallas & Blind, 2019). Furthermore, innovations from R&D activity is not easily judged for their competitive worthiness because of their high degree of relatedness to the business (Qian *et al.*, 2017). Risk is commonly associated with innovation (Keizer & Halman, 2007). This risk is based on incomplete information and bounded rationality during decision making process (Goes & Park, 1997). This discussion suggests that executives in not-survived firm may keep investing in R&D but fail to realize influences of competitive risks based on innovation. Therefore, hypothesis 2b is proposed.

H2b: Innovation-related competitive risks do not affect R&D investment behavior in not-survived IT firms

METHODOLOGY

Controls

This study controls for firm size and for changes in operating expenses. The effects of uncertainty are not similar across firm sizes (Doshi, Kumar, & Yerramilli, 2018). Larger firms differently behave from smaller firms do when they face quite similar risks. Firm size, therefore, must be controlled. Furthermore, operating expenses indicate over-all firm day-to-day operations. Changing in this expense could signify change in strategic direction of the firm (Ramaswamy, 1997). Controlling for this change is to normalize effects of any change in the direction.

Measures

This study measures the R&D investment behavior by year-to-year growth rate of the R&D expenditure in percentage. Changes in firm operating expenses are captured in percentage terms of year-to-year growth rate of the operational expenditure, excluding R&D expenditure. Size of a firm is measured by its natural logarithm of sales.

The innovation-related competitive risk is defined in terms of degree of innovation-related threats recognized by firm in its annual report. It is measured in percentage of number of sentences with innovation-related word over number of all sentences in item 1a risk factors section of firm's 10-K annual report. The extraction of the numbers of sentences is done by a custom-built python program with the help of Natural Language Tool Kit (NLTK) package version 3.4.5. Sentences are identified using *PunktSentenceTokenizer* routine in *nltk.tokenize.punkt* library. The following terms are used to identify innovation-related threats: innovation, technology, creativity, creative, research, development, new, and patent. This study carried out synonymization of the terms using the *synsets* routine in *nltk.corpus.wordnet* library before identification of sentences. The pipeline to obtain the innovation-related risk is visualized in figure 1.

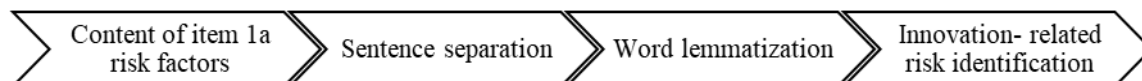

Figure 1: Innovation-related risk extraction pipeline

Data collection

This study carried out a cross-section research design. Data record format is in firm-year. Annual financial data of IT firms was collected from Compustat-North America database. IT firms are identified by NAICS industry code 51. Data is extracted between January 2008 and June 2019. The extraction is filtered by R&D expenditure more than zero and CIK (i.e., Central Index Key) is not empty. The extraction yielded 826 firms with 4,544 firm-year records in both active and inactive firms.

Annual reports form 10-K during the data extraction period of the 826 firms were downloaded from EDGAR system of U.S. security and exchange commission. Two thousand eight hundred eighty-two firm-year reports were successfully downloaded, which is equal to 63.4% of firm-year records from Compustat database. The reason for unsuccessful download is that the 10-K reports of those firm-year were not presented on the EDGAR system.

Item 1a risk factors of each report are extracted using a custom-build pattern recognition program. The program successful extracted 2,517 firm-years (87% of downloaded 10-K reports). Examination of the unsuccessful extractions reveals two major reasons. First, for the majority, the item 1a was omitted form the reports. Second, the programs failed to recognized patterns due to unusual report layout.

The calculation of year-to-year grown in R&D investment behavior and in normal operation behaviors are performed on the 2,517 firm-years. Growths of 315 firm-years could not be calculated because of the missing data in prior years. This brings valid data down to 2,202 firm-years. There are 84 firm-years with year-to-year growth of R&D investment more than 100%. These records are removed because they unduly influence the distribution of the variable. The negative-growth is theoretically limited to only -100%. Therefore, positive-growth is administratively limited to 100%. Following the same argument, twenty-two firm-years are removed because year-to-year growth of normal operation expenditure are more than 100%. Examining sale figures reveals 9 firm-years with zero dollar reported. These nine firm-years are removed because natural logarithm of sales calculation cannot be performed. A total of 430 firm-years is removed from the 2,517 firm-years, which is amount to 17%. Therefore, eighty-three percent (83%) or two-thousand eighty-seven (2,087) firm-years are left for hypothesis testing.

This study makes distinction between two groups of IT firms: survived and not-survived. The survived firms are identified by the active status in the Compustat database. While, the inactive status indicates not-survived IT firms. Inactive status in the database is a result of firm's bankruptcy or liquidation (Swift, 2016).

Hypothesis Testing

Descriptive statistics of both survived and not-survived IT firms are in table 1 and table 2 respectively. Skewness and kurtosis statistics are mostly within the recommended boundaries -2 and +2. There are few instances where kurtosis statistics are over the boundary. Nonetheless, these statistics indicate that the variables are largely normally distributed.

Table 1: Descriptive statistics of survived IT firms (N=1,397 firm-years)

	Mean	S.D.	Skewness	Kurtosis
Year-to-year R&D investment growth (%)	10.59	27.04	-0.21	2.22
Year-to-year operating expenses growth (%)	9.52	20.68	-0.07	1.96
Log Sales	2.35	1.04	-0.53	1.68
Innovation-related risks	0.22	0.05	0.56	2.18

Table 2: Descriptive statistics of not-survived IT firms (N=690 firm-years)

	Mean	S.D.	Skewness	Kurtosis
Year-to-year R&D investment growth (%)	11.28	28.58	0.23	1.09
Year-to-year operating expenses growth (%)	8.75	22.25	0.34	1.51
Log Sales	2.17	0.66	-0.66	3.06
Innovation-related risks	0.22	0.06	0.33	0.88

Independent sample *t*-test is carried out to test hypothesis 1. Levene's test for equality of variance reject null hypothesis ($F=4.928$, $p = 0.027$). Equal variance assumption is not assumed. *T*-test is used to examine differences of R&D investment growth between successful and unsuccessful IT firms. The *t*-statistics is 0.524 with probability at 0.6. Therefore, null hypothesis is retained. This study found no significance difference of R&D investment growth between survived and not-survived IT firms.

Table 3: Independent samples *t*-test

	Levene's Test	<i>t</i> -test
Year-to-year R&D investment growth (%)	$F=4.928$, $p=0.027$	$t=0.524$, $p=0.60$

This study utilized multiple regression statistical model to address hypothesis 2a and hypothesis 2b. Results of the models are in table 4 and table 5. An examination of tolerance and VIF statistics is performed to identify multicollinearity problem. All Tolerance statistics is more than prescriptive value at 0.3 and all VIF statistics is less than recommended value at 5 (Hair *et al.*, 1998). Therefore, multicollinearity among variables would not interfere with the regression results.

Table 4: Regression year-to-year R&D investment growth of survived IT firms

Successful IT firms (N=1,397)	STD β	<i>t</i>	<i>P</i>	Tolerance	VIF
Innovation-related risks	0.057	2.54	0.01	0.99	1.01
Year-to-year operating expenses growth (%)	0.509	22.14	0.00	0.96	1.04
Log Sales	0.092	4.01	0.00	0.97	1.04

Table 5: Regression year-to-year R&D investment growth of not-survived IT firms

Unsuccessful IT firms (N=690)	STD β	<i>t</i>	<i>P</i>	Tolerance	VIF
Innovation-related risks	0.041	1.45	0.15	0.95	1.05
Year-to-year operating expenses growth (%)	0.617	20.05	0.00	0.92	1.09
Log Sales	0.044	1.33	0.19	0.90	1.11

Both hypothesis 2a and 2b are supported by the statistical results in table 4 and table 5 respectively. Table 4 reveals that innovation-related risks positively impact year-to-year R&D investment growth of survived IT firms ($t = 2.54$, $p = 0.01$). On the other hand, the risk demonstrates no relationship with year-to-year R&D investment growth of unsuccessful IT firms ($t = 1.45$, $p = 0.15$) in table 5. These results suggest that innovation-related competitive risks differently affect survived and not-survived IT firms in terms of year-to-year R&D investment growth.

RESULT

This study seeks to uncover relationships between R&D investment and innovation-related risk of IT firms. It focuses on the investment behavior of survived and not-survived IT firm when innovation-related competitive risk is considered. Two research questions are posted, and three hypotheses are formulated from the literature. A cross-sectional dataset is collected from Compustat database and from 10K annual reports. The data consists of two-thousand eighty-seven IT firm-years and is used to test hypotheses. Statistical results reveal the following.

1. There is no difference in terms of R&D investment growth rate between survived and not-survived IT firms.
2. Innovation-related competitive risk has positive effect on R&D investment growth rate of survived IT firm.
3. Innovation-related competitive risk has *no* effect on R&D investment growth rate of not-survived IT firm.

DISCUSSION

Above findings shed lights on the two research questions. The first question, is general R&D investment behavior significantly contribute to IT firm survival? The findings reveal no *ex post* difference between the two types of IT firms. The implication is that IT firms could not *ex ante* predict that their R&D investment behaviors would either make or not make them stay on the competition. Executive of IT firms should not expect R&D investment as the silver bullet that increases chances of firm's survival. This finding agrees with a recent investigation on innovation value chain by Chen, Liu & Zhu (2018). They find that commercialization process is significant in the making of successful innovation, which is responsible for superior return on R&D investment and for firm's bottom line.

The second research question, how do innovation-related competitive risks contribute R&D investment behavior in the context of survived and of not-survived IT firms? Testing of hypothesis 2a and hypothesis 2b suggest that the risks have positive effects on R&D investment of survived firms but no effects on that of not-survived firms. Yoon *et al.* (2020) recently reveal that R&D investment involve product's quality that leads to customers' satisfaction should be given higher priority. Their finding suggests a specific area of competitive risks where executive must emphasize. Future research could help reveal more specific areas. Nonetheless, this discussion is a note to any IT executive. The executive must be able to connect competitive risks in these areas to actual R&D investment in order to survive competition. Connecting competitive risks with R&D investment advances an argument by Bromiley, Rau, & Zhang (2017) that R&D investment cannot be used as indicator of risk-taking investment. This study suggests that R&D investment is considerably a risk mitigation investment by making firm better handling innovation-related uncertainties.

Literature reviewer earlier suggests a chain connecting R&D investment to firms' survival as depicted here again.

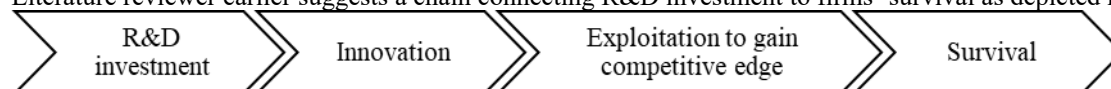

Insights form this study shed light that the “exploitation to gain competitive edge” could be explicated in terms of “mitigating innovation-related risks”. Therefore, a refined chain of events is depicted as the following.

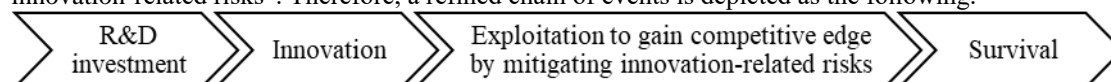

CoVID-19 pandemic increase business uncertainty. However, several IT firms have demonstrated their resilience during the pandemic. These firms are well-positioned with products and services, which support social distancing activities. However, these firms cannot rest on their laurels because the new-normal world has yet established. Innovation must move forward. IT firm should not irrationally follow a paradigm that increasing R&D investment somehow equate to increasing chances to survive. This study finds no such relationship. This insight is particularly relevant in post pandemic world. The resources are sacred because the prolonged and reduced economic activities. Any investment must be made carefully. To survive, IT firm should focus and prioritize its R&D investment on areas where innovation-related competitive risk is expected, particularly in the area where customer satisfaction is involved. Investing in R&D to reduce competitive risks is effectively increasing chances of the firm's survival.

REFERENCES

- [1] Bromiley, P., Rau, D., & Zhang, Y. (2017). Is R&D risky? *Strategic Management Journal*, 38(4), 876-891.
- [2] Calof, J., & Smith, J. (2010). The integrative domain of foresight and competitive intelligence and its impact of R&D management. *R&D Management*, 40(1), 31-39.
- [3] Chen, X., Liu, Z., & Zhu, Q. (2018). Performance evaluation of China's high-tech innovation process: Analysis based on the innovation value chain. *Technovation*, 74, 42-53.
- [4] Custódio, C., Ferreira, M. A., & Matos, P. (2019). Do general managerial skills spur innovation? *Management Science*, 65(2), 459-476.
- [5] Doshi, H., Kumar, P., & Yerramilli, V. (2018). Uncertainty, capital investment, and risk management. *Management Science*, 64(12), 5769-5786.
- [6] Dziallas, M., & Blind, K. (2019). Innovation indicators throughout the innovation process: An extensive literature analysis. *Technovation*, 80-81, 3-29.
- [7] George, G., Wiklund, J., & Zahra, S. A. (2005). Ownership and the internationalization of small firms. *Journal of Management*, 31(2), 210-233.
- [8] Goes, J. B., & Park, S. H. (1997). Interorganizational links and innovation: The case of hospital services. *Academy of Management Journal*, 40(3), 673-696.
- [9] Hair, J. F., Black, W. C., Babin, B. J., Anderson, R. E., & Tatham, R. L. (1998). *Multivariate data analysis* (Vol. 5, No. 3, pp. 207-219). Upper Saddle River, NJ: Prentice hall.
- [10] Keizer, J. A., & Halman, J. I. (2007). Diagnosing risk in radical innovation projects. *Research-Technology Management*, 50(5), 30-36.

- [11] Khanagha, S., Ramezan Zadeh, M. T., Mihalache, O. R., & Volberda, H. W. (2018). Embracing bewilderment: responding to technological disruption in heterogeneous market environments. *Journal of Management Studies*, 55(7), 1079-1121..
- [12] Kuo, C. I., Wu, C. H., & Lin, B. W. (2019). Gaining from scientific knowledge: the role of knowledge accumulation and knowledge combination. *R&D Management*, 49(2), 252-263.
- [13] Levitt, B., & March, J. G. (1988). Organizational learning. *Annual Review of Sociology*, 14(1), 319-338..
- [14] Makri, M., Lane, P. J., & Gomez-Mejia, L. R. (2006). CEO incentives, innovation, and performance in technology-intensive firms: a reconciliation of outcome and behavior-based incentive schemes. *Strategic Management Journal*, 27(11), 1057-1080.
- [15] Pérez, J. A. H., Geldes, C., Kunc, M. H., & Flores, A. (2019). New approach to the innovation process in emerging economies: The manufacturing sector case in Chile and Peru. *Technovation*, 79, 35-55.
- [16] Qian, C., Wang, H., Geng, X., & Yu, Y. (2017). Rent appropriation of knowledge-based assets and firm performance when institutions are weak: A study of Chinese publicly listed firms. *Strategic Management Journal*, 38(4), 892-911.
- [17] Ramaswamy, K. (1997). The performance impact of strategic similarity in horizontal mergers: Evidence from the U.S. banking industry. *Academy of Management Review*, 40(3), 697-715.
- [18] Swift, T. (2016). The perilous leap between exploration and exploitation. *Strategic Management Journal*, 37(8), 1688-1698.
- [19] Urbinati, A., Bogers, M., Chiesa, V., & Frattini, F. (2019). Creating and capturing value from Big Data: A multiple-case study analysis of provider companies. *Technovation*, 84, 21-36.
- [20] Xin, M., & Choudhary, V. (2019). IT Investment under competition: The role of implementation failure. *Management Science*, 65(4), 1909-1925.
- [21] Yoon, B., Jeong, Y., Lee, K., & Lee, S. (2020, December). A systematic approach to prioritizing R&D projects based on customer-perceived value using opinion mining. *Technovation*, 98, 1-19.

Rural Destination revitalization in Shennongjia Forestry District: A Tourism Poverty Alleviation Perspective

(Work in Progress)

Junyang Lu, School of Business Administration, Zhongnan University of Economics and Law, Wuhan, China, 430073; School of Tourism, Xinyang Normal University Xinyang, China; Email: juntaiyang628@163.com

Aimin Deng, School of Business Administration, Zhongnan University of Economics and Law, Wuhan, China, 430073; Email: Dam99@163.com

Penghao Ye*, School of Business Administration, Zhongnan University of Economics and Law, Wuhan, China, 430073, Email: paullyph@whu.edu.cn

ABSTRACT

Tourism development is an important way to eliminate poverty. Existing research in this area has been mostly based on western experiences; In this context, there is a lack of research on how to promote rural revitalization through tourism, especially in these poverty-stricken areas. This study fills this research gap by selecting and evaluating the developing process of Shennongjia Forestry District in China. Tourism is considered a way to mitigate poverty in the region, and make a great effort and ultimately revive the economy and culture of the region. Shennongjia Forestry District illustrates the importance of initial conditions and how the government attaches great importance to the development of the region and poverty alleviation policies can help mitigate shortfalls in those initial conditions. We summarize many successful practices in Shennongjia Forestry District in different phases, especially the application of e-commerce in tourism poverty alleviation, and concluded that by addressing the needs of tourists and providing proper products, and a number of poverty alleviation measures have really worked. Study results also showed that the development of tourism has driven the development of other industries, and the construction of government support network has indeed had a profound impact on poverty alleviation. This requires the participation of local communities to jointly advance tourism development.

Keywords: Rural revitalization; tourism development; poverty alleviation; Shennongjia Forestry District; China.

*Corresponding author

INTRODUCTION

Rural destinations are experiencing a global crisis, particularly in developing countries. More and more rural dwellers have abandoned their houses and lands, moving to larger cities to strive for better jobs, higher educations, and more reliable medical services (Deng, Lu & Zhao, 2020). As a result, hometowns have become hollow villages; traditional agriculture and daily life is now disappearing or undergoing homogenization through urbanization and economic concentration. Critical issues remain unresolved, such as how to revitalize rural destinations. This calls for attention by both academics and industry (Yachin & Ioannides, 2020; Gao & Wu, 2017).

Tourism development is usually considered to be an effective means to balance the adverse effects of economic restructuring, especially in rural areas (Gao & Cheng, 2020; Müller & Jansson, 2007). A successful tourism project can advance the transformation of economic development at a low environmental cost. This usually requires rich resources (natural or cultural), adventure experiences, superior locations, and an economic base (Ma & Hassink, 2013).

Past research has studied the development of destinations under the complete market economy system; however, fewer studies have examined the development of destinations in incomplete market economy systems (Halkier, et al., 2019). China is a representative of the typical incomplete market economy system, with many villages and uneven development conditions. The Chinese government has recently advocated developing rural tourism to realize a national strategy to alleviate poverty (Zhang & Zhang, 2020). This has advanced the process of rural revitalization in China. To emphasize universality, Shennongjia Forestry District in China was selected for the study. This work can shed light on rural tourism development in other different regions.

Therefore, this study explains the emergence and prosperity of Shennongjia Forestry District in China during the past 8 years, assessing how tourism lifted the poor people out of poverty and produced regional effects. This study contributes to the emerging path creation research agenda by developing a fuller understanding of this process (Deng, Lu & Zhao, 2020). To achieve this goal, the following research questions were considered: how do Shennongjia Forestry District alleviate poverty

through the development of tourism? What is the way to advance rural revitalization? What experiences can Shennongjia Forestry District be used for reference by other regions?

LITERATURE REVIEW

The worldwide degradation of rural areas has been a general situation because of urbanism. A traditional village would rapidly decay if it does not diversify from a sole dependence on agriculture to a wider range of socio-economic activities (Gao & Wu, 2017; De Souza, 2017). The shrinkage of rural areas can lead to the population loss of the rural area, in terms of population density. This emphasizes the necessities and urgencies of exploring a rural economic transformation mode (Gao & Cheng, 2020). Involving tourism into rurality may be a relatively effective worldwide development path. Rural tourism can boost market economies and create relevant jobs; then governments and researchers credit it with keeping back the Floating population in rural areas (Flisher & Felsenstein, 2000). This encouraging more cultural exchange between downtown area and countryside area, and enhancing the traditional values of rural life, as well as contributing to the Economic Diversification (Yachin & Ioannides, 2020; Sharpley & Sharpley, 1997; Roberts & Hall, 2001; Cánovesetal, 2004). Thus, rural tourism should not, however, be understood merely as a type of tourism. It is also a tool to conserve and regenerate rural societies and local life-styles. Rural restructuring supported by tourism has gradually become an effective pillar for promoting economic integration and revitalizing other rural business activities (Tu, et al., 2018). However, some studies have speculated that an over-reliance on tourism may lead to problems (Gao, et al, 2014; Schmallegger & Carson; 2010).

As mentioned above, tourism can provide a solution to economic transformation in rural areas, especially when other industries are depressed (Halkier, et al., 2019). However, the transition from the old rural economy to a new economic paradigm is not a simple process. Rather, it involves pilot projects, learning and summarizations, novel findings, creative policies, feedbacks and re-adjustments. In addition, the geographical distribution of the transition alters the background of every process. As a result, policymakers should consider self-supply with the existing endowments, labors, and the market to infuse the actions to the advancing active processes, local and global (Mutana & Mukwada, 2019; Mackinnon, et al., 2018).

Therefore, to address sustainable rural development, research should be focused more on mechanism and course rather than on local resources (Randelli, Romei, & Tortora, 2014). In practice, the key issues involve balancing the needs and perspectives of different stakeholders and managing them equitably and efficiently. However, issues remain concerning how stakeholders form partnerships in different regions, development stages, and levels; and the factors that should be considered and need to be addressed.

METHODS AND CASE STUDY AREA

Case studies can provide detailed information on specific factors, based on interviews and observation; highlight the most apparent facilitators and barriers faced by a region during the initiation and/or operation of tourism (Zielinski, et al., 2020). Hence, the case study data can provide important evidence and insights into the evolutionary process of tourism area development. The data of this paper is mainly from Shennongjia Forestry District Precise Poverty Alleviation battle headquarters Offices (hereinafter referred to as SFDPPAO).

Shennongjia area, commonly known as Shennongjia Forestry District due to its high forest coverage rate, is located in the northwest of Hubei Province (Figure 1). Established in 1970, Shennongjia is the only administrative division in China named after "forest area", which is directly under the jurisdiction of Hubei Province. The area covers a total area of 3,253 square kilometers, with a total area of 109°56' ~ 110°58' east longitude and 31°15' ~ 31°75' north latitude.

Shennongjia Forestry District has jurisdiction over 6 towns and 2 townships, 1 national nature reserve, 1 state-owned forest industry enterprise forestry administration, and 1 national wetland park, with forest land accounting for more than 85%. Shennongjia is the first place in China to be inscribed on the "Triple Crown" list of UNESCO's Man and Biosphere Nature Reserve, World Geopark and World Heritage Sites. On July 17, 2016, Shennongjia was added to the World Heritage List, becoming the first world Natural heritage site in Hubei Province and the 11th in China.

In general, the local government has effectively helped local residents out of poverty through efforts (Table 1), and it is noteworthy that on August 7, 2018, the government of Hubei Province approved Shennongjia Forest district to be removed from poverty. In September 2018, it won the title of "China's Natural Oxygen Bar". In March 2019, it was listed as one of the first counties for the protection and utilization of revolutionary cultural relics.

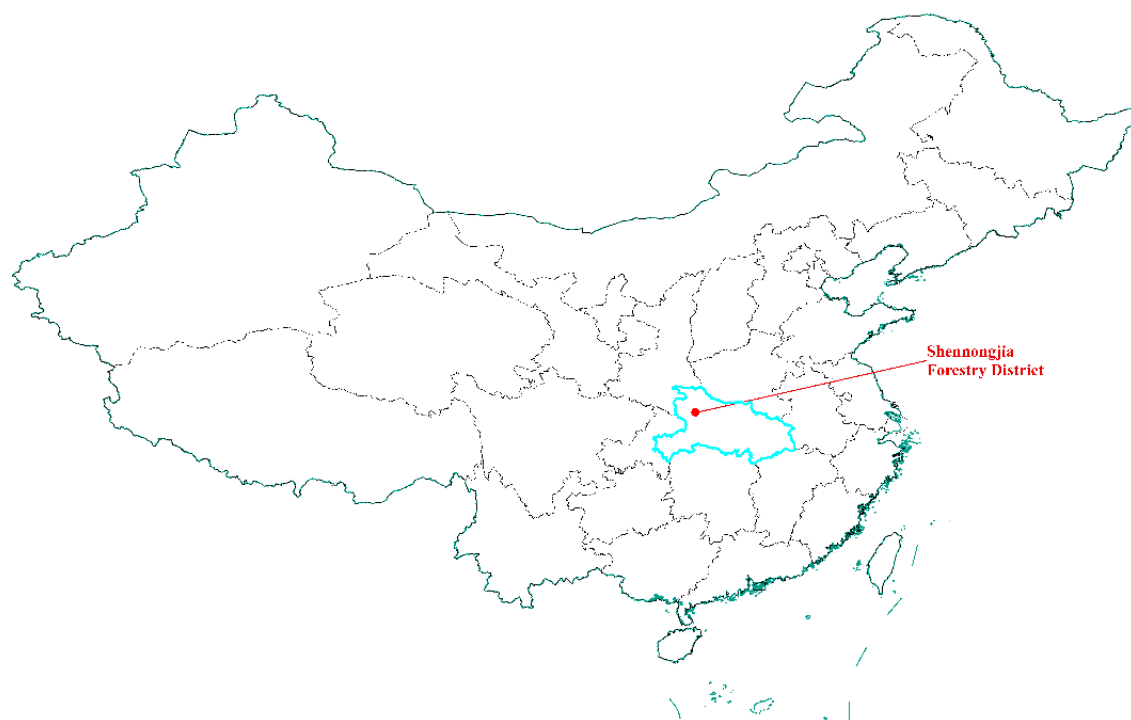

Figure 1: Case study area in China

Table 1: Summary data of targeted rural township poverty alleviation in Shennongjia Forestry District (The statistical unit is the number of households or persons)

No.		1	2	3	4	5	6	7	8	Total
Rural township		Songbai	Yangri	Muyu	Hongping	Xinhua	Dajiuhu	Songluo	Xiagu	
Inputting record	Households	765	1010	534	588	442	517	844	778	5478
	Population	1969	2989	1304	1685	1343	1617	2534	2342	15783
Poverty-alleviation in 2014	Households	64	319	115	65	57	64	101	100	885
	Population	186	1045	163	205	177	258	201	328	2563
Poverty-alleviation in 2015	Households	111	182	88	60	63	157	96	103	860
	Population	338	656	240	234	203	487	375	348	2881
Poverty-alleviation in 2016	Households	350	277	190	278	146	241	375	374	2231
	Population	968	827	532	880	488	733	1298	1204	6930
Poverty-alleviation in 2017	Households	238	228	136	182	171	54	265	189	1463
	Population	468	450	354	360	460	137	643	422	3294
Poverty-alleviation in 2018	Households	All these rural townships were officially announced to be removed of the title "Impoverished mountain county" in 2018.								
	Population	(Source: http://www.hubei.gov.cn/zfwj/ezh/201808/t20180824_1712302.shtml)								

Source: The data in this table is from SFDPPAO.

RESULTS

Shennongjia Forestry District has made active exploration in promoting regional poverty alleviation through tourism development. The development of tourism drives the overall development of other industries and constantly improves the rural public service system.

Shennongjia Forest District Party Committee played the core role. The first secretary of each village is the head and concurrent post of the district direct unit, effectively integrating capital, projects, talents and other resources to help the development of the industry. Take Week as the unit to promote regularly, set up a carry red and yellow flag, the last position of the speech system, encourage and urge to create a competitive atmosphere. They carry out in-depth research on poor villages and households, analyze the reasons for the lack of development capacity, and adopt targeted policies for each household and village. They combine measures to increase industrial growth and alleviate poverty. They improved the sustainable development of poor villages through tourism poverty alleviation, photovoltaic poverty alleviation, enterprise assistance, and share in dividends.

The local government attaches importance to industrial development to alleviate poverty. Based on the characteristic tourism resources -- the "Triple Crown" heritage site, they promote regional tourism. They develop tourism products in accordance with local conditions, hold various tourism festival activities, create a number of quality tourism routes. Residents here achieve poverty alleviation through running farmhouses, famous tourist villages, ecological leisure agriculture and scenic spot driving. Meanwhile, the modern planting industry and organic agricultural products are built according to local conditions. As a result, these measures worked, and the number and income of tourists in the Shennongjia forest area increased significantly (Figure 2).

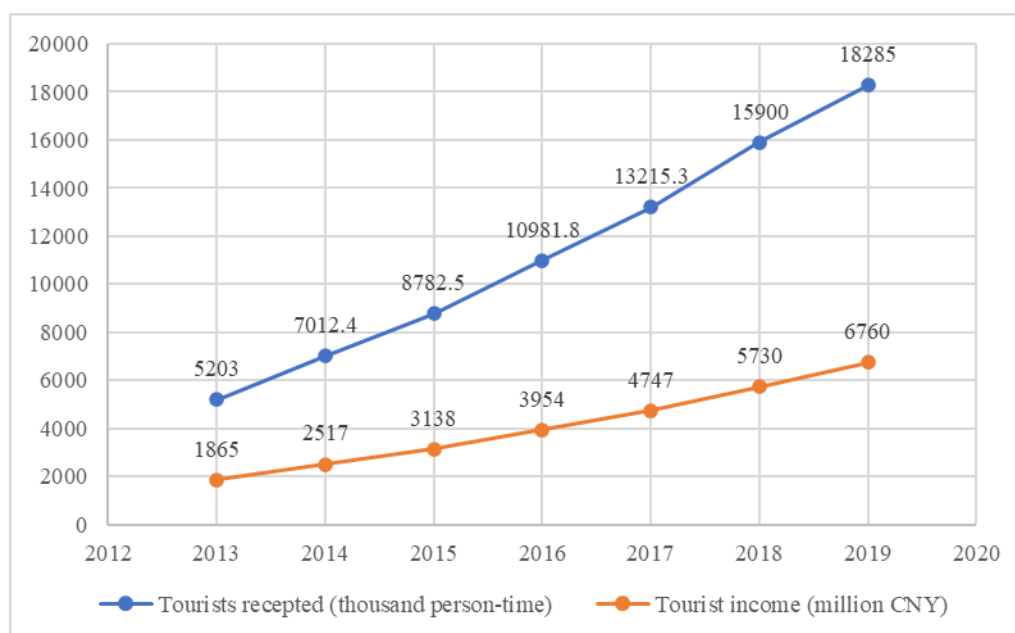

Source: The data in this table was partly from SFDPPAO, and the other was from regional statistics.

Figure 2: The number and income of tourists in Shennongjia since 2013

Since most of the poor people are in rural areas, the government has made overall arrangements for the infrastructure construction and resource protection of each village. They comprehensively improve the rural environment and renovate dilapidated houses, and infrastructure for residents, such as water, electricity, roads, telecommunications, landscaping, and lighting, they improved living conditions throughout the area.

The government actively seeks funds to upgrade the existing health facilities and equipment, and improves the local medical level by means of medical trust, remote consultation, personnel training, in-depth exchange and new hospital. Meanwhile, they also improve the level of running schools in towns and villages by optimizing the layout and integrating resources, and actively supplements and improves vocational education and skill training, ensures that vocational high school and vocational college students can also receive systematic education and training, and rely on industrial development to start businesses and find jobs. They expand funding channels and build a comprehensive funding system from pre-school to universities to ensure that poor students can attend school smoothly. Precision is the most important part of targeted poverty alleviation. Therefore, it is necessary to first identify the poor areas and populations, and carry out targeted poverty alleviation, poverty alleviation relocation, ecological compensation and other means according to the specific conditions.

They attach importance to the integration of tourism and other industries, and provide training for poor residents, strengthen their skills, and enable them to find jobs and start businesses by relying on characteristic industrial zones, enterprises and eco-tourism zones so that they can get out of poverty through work. With manual weaving, tourism, farmhouse and e-commerce services, they developed new industries to drive rural poor women to increase their income and get rid of poverty through intellectual assistance, organization and coordination, and employment assistance.

DISCUSSIONS

They make full use of regional ecological culture tourism resources in Shennongjia Forestry District since 2013, tourism poverty alleviation and development, in-depth practice "green water castle peak is the gold mountain" concept of development, the combination of a variety of mechanisms coordinated development. With these efforts, they promote the precision of the breakthrough and alleviate poverty in Shennongjia Forestry District. Hence, they also explore some conform to the laws of ecological protection, remote mountainous areas development, and the laws of tourism economic development practice and experience.

Explore a model of efficient development based on reality

(1) Based on reality, they carefully select the leading industry. Remote mountainous areas usually have a good ecological environment and unique local culture. Tourism, with its strong correlation and low pollution, should be given priority to development.

(2) Driven by tourism, the industry in this district develops in an all-round way. For example, the rural households in the vicinity of the tourist area got rid of poverty and became rich through the operation of the farmhouse; Along the road, these farmers give full play to their traffic advantages, build ecological farms, family forest farms (named "Lin Jiale" in Chinese), and develop garden sightseeing. Farmers in other regions take advantage of the ecological advantages of Shennongjia to produce or sell featured tourism commodities such as soil honey, tea, Chinese medicinal materials, soil pig and forest chicken, and develop sales channels by relying on enterprises such as Shennongjia Shopping and e-commerce.

(3) Innovate organizational model and promote efficient development, Combine the role of the Internet of Things, mobile Internet and other information technologies to realize the transformation of products into industrialization through the mode of "e-commerce + tourism + agricultural products + training"; On the basis of guaranteeing farmers' interests, industrial organizations should innovate in the forms of human stock, lease, subcontract, concession and trusteeship.

Strengthening policy support for poverty alleviation under the leadership of the government

The government is the leader of poverty alleviation and the coordinator of the development of tourism and other industries. The first step is to establish government leadership and give full play their activity. Second, the Party Committee should play its core role of overall leadership and coordinating all parties, strictly implement the one-person responsibility system for poverty alleviation, and effectively integrate funds and projects to provide support for the development of tourism. Third, they also actively mobilize the enthusiasm of community-level Party organizations and the masses, select community-level cadres with strong abilities, responsibilities and dedication, and encourage them to devote themselves to poverty alleviation and development, so as to enhance cohesion. Finally, a scientific and comprehensive follow-up support and consolidation promotion mechanism should be established to strictly implement the requirements of "taking off the poverty cap without taking off responsibility, policies, assistance and supervision".

Change ideas and straighten out the thinking on rural development

Relying on basic conditions, they choose industries with distinctive features according to local conditions, change traditional development concepts, and straighten out rural development ideas. First, improve the autonomy of residents in poor areas in project development, so that they can have more power in decision-making and supervision, supervise the whole process of design, development and operation of poverty alleviation projects like tourism, and make development projects open and transparent. Second, change the concept of rural operation, and deepen the definite rights of forest, water, land and housing rights of residents in poor areas, so that they can enter the tourism industry smoothly. Third, build confidence and determination to get rich through hard work, and promote the residents of poor areas to lift themselves out of poverty with dignity in the course of rural revitalization and tourism development.

Relocate the poor in the inhospitable areas to other area and ensure that supporting industries lift them out of poverty

Before relocation, the government organizes development, reform, forestry and other departments to go deep into towns and townships, adopt on-site office and one-stop handling methods, and centrally countersign and approve the site selection, planning, and nature of land use of the centralized settlement sites, so as to quickly start the preliminary procedures. Adhere to the follow-up industrial development throughout the relocation work, in accordance with the idea of both housing and happiness, relocation and poverty alleviation, do a good job in supporting industries.

Managerial implications for electronic business: Poverty alleviation by E-commerce

Give full play to the platform advantage of e-commerce, strengthen the construction of social poverty alleviation websites, and encourage social capital and Internet resources to enter the poverty alleviation system. They guide outstanding enterprises and organizations to jointly promote the development of poor areas, integrate social resources to the maximum extent possible, and promote the formation of an overall pattern of social poverty alleviation. Strive for domestic and foreign assistance, build a perfect e-commerce platform for agricultural products, optimize the allocation of resources, improve the logistics system, through the e-commerce system to perfect the docking of product demand and supply. And through the e-commerce system, they are able to promote the local products and the popularity of the tourist attractions. They also organize poverty alleviation projects such as tourism development, and organize agricultural and tourism professional companies and other units to promote value creation.

E-commerce contributes to poverty alleviation by promoting cash flows and information flows through the prevalent traveling mobile apps, such as AirbnbTM, CtripTM, eLongTM, MetuanTM, QunarTM, FliggyTM, Little Red BookTM, and TripadvisorTM, etc.; or by stimulating the electronic transaction of the souvenirs and the special local products in the e-commerce platforms, such as TaobaoTM, JD.comTM and PinduoduoTM. Hence, by Web crawlers' techniques and quantitative analysis, we can conduct the correlation analysis on the linkage between poverty alleviation through tourism and e-commerce in an explicit way.

ACKNOWLEDGMENT

This research was funded by Soft Science Research Project of Henan Province, China. [Project No. 182400410492]; This research was funded by China Scholarship Council [grant number CSC201907080003].

REFERENCES

- [1] Ashworth, G., & Page, S. J. (2011). Urban tourism research: Recent progress and current paradoxes. *Tourism Management*, 32(1), 1-15.
- [2] Beaumont, N., & Dredge, D. (2010). Local tourism governance: A comparison of three network approaches. *Journal of Sustainable Tourism*, 18(1), 7-28.
- [3] Bramwell, B. (2010). Participative planning and governance for sustainable tourism. *Tourism Recreation Research*, 35(3), 239-249.
- [4] Chen, G., Huang, S., & Bao, J. (2016). The multiple logics of tourism development in China. *Journal of Sustainable Tourism*, 24(12), 1655-1673.
- [5] DeLorenzo, J., & Techera, E. J. (2019). Ensuring good governance of marine wildlife tourism: a case study of ray-based tourism at Hamelin Bay, Western Australia. *Asia Pacific Journal of Tourism Research*, 24(2), 121-135.
- [6] Deng, A., Lu, J., & Zhao, Z. (2020). Rural destination revitalization in China: applying evolutionary economic geography in tourism governance. *Asia Pacific Journal of Tourism Research*, 1-16. doi: 10.1080/10941665.2020.1789682
- [7] De Souza, P. (2017). *The Rural and Peripheral in Regional Development: An Alternative Perspective*. Routledge, London.
- [8] Doussard, M., & Schrock, G. (2015). Uneven decline: Linking historical patterns and processes of industrial restructuring to future growth trajectories. *Cambridge Journal of Regions, Economy and Society*, 8(2), 149-165.
- [9] Duran, C. (2013). Governance for the tourism sector and its measurement, *UNWTO statistics and TSA issue paper series STSA/IP/2013/01*.
- [10] Fleischer, A., & Felsenstein, D. (2000). Support for rural tourism: Does it make a difference? *Annals of Tourism Research*, 27(4), 1007-1024.
- [11] Gao, C., & Cheng, L., (2020). Tourism-driven rural spatial restructuring in the metropolitan fringe: An empirical observation. *Land Use Policy*, 95(6), 1-12.
- [12] Gao, J., & Wu, B. (2017). Revitalizing traditional villages through rural tourism: A case study of Yuanjia Village, Shanxi Province, China. *Tourism Management*, 63, 223-233.
- [13] Gao, H., Zhang, J., Luo, Z., (2014). Renaissance or alienation? Spatial transformation of rural space of metropolis fringe area driven by consumer culture: empirical observation on Dashan Village of Gaochun International Slow City. *Urban Planning International*, 29, 68-73. http://en.cnki.com.cn/Article_en/CJFDTotal-GWCG201401012.htm
- [14] Gill, A. M., & Williams, P. W. (2011). Rethinking resort growth: Understanding evolving governance strategies in Whistler, British Columbia. *Journal of Sustainable Tourism*, 19(4-5), 629-648.
- [15] Hwang, D., Stewart, W. P., & Ko, D. W. (2012). Community behavior and sustainable rural tourism development. *Journal of Travel research*, 51(3), 328-341.
- [16] Jamal, T., & Camargo, B. A. (2018). Tourism governance and policy: Whither justice? *Tourism Management Perspectives*, 25, 205-208.
- [17] Mayaka, M., Croy, W. G., & Cox, J. W. (2019). A dimensional approach to community-based tourism: Recognising and differentiating form and context. *Annals of Tourism Research*, 74, 177-190.
- [18] Manyara, G., & Jones, E. (2007). Community-based tourism enterprises development in Kenya: An exploration of their potential as avenues of poverty reduction. *Journal of Sustainable Tourism*, 15(6), 628-644.
- [19] Miles, M. B., Huberman, A. M., & Saldana, J. (2014). *Qualitative Data Analysis: A Methods Sourcebook* (3rd ed.). Los Angeles: SAGE.
- [20] Mobedi, E., & Tanyeri, M. (2019). Comparison of two cluster life stages in a synthetic knowledge base. *European Planning Studies*, 27(9), 1687-1708.
- [21] Mutana, S., & Mukwada, G. (2020). Are policies and guidelines shaping tourism sustainability in South Africa? Critical Success Factors for tourism sustainability governance in the Drakensberg Region. *Tourism and Hospitality Research*, 20(2), 198-209. doi:10.1177/1467358419841100
- [22] Nair, V., Munikrishnan, U. T., Rajaratnam, S. D., & King, N. (2015). Redefining rural tourism in Malaysia: A conceptual perspective. *Asia Pacific Journal of Tourism Research*, 20(3), 314-337.
- [23] Ooi, N., Duke, E., & O'Leary, J. (2018). Tourism in changing natural environments. *Tourism Geographies*, 20(2), 193-201.

- [24] Qian, C., Sasaki, N., Shivakoti, G., & Zhang, Y. (2016). Effective governance in tourism development an analysis of local perception in the Huangshan mountain area. *Tourism Management Perspectives*, 20, 112–123.
- [25] Roberts, L., Hall, D., (2001). *Rural Tourism and Recreation: Principles to Practice*. CABI, Wallingford.
- [26] Schmallegger, D., & Carson, D. (2010). Is tourism just another staple? A new perspective on tourism in remote regions. *Current Issues in Tourism*, 13(3), 201-221.
- [27] Sharpley, J., Sharpley, R., (1997). *Rural Tourism: An Introduction*. International Thomson Business Press, London.
- [28] Siakwah, P., Musavengane, R., & Leonard, L. (2020). Tourism governance and attainment of the Sustainable Development Goals in Africa. *Tourism Planning & Development*, 17(4), 355-383.
- [29] Tu, S., Long, H., Zhang, Y., Ge, D., & Qu, Y. (2018). Rural restructuring at village level under rapid urbanization in metropolitan suburbs of China and its implications for innovations in land use policy. *Habitat International*, 77, 143-152.
- [30] Van Leeuwen, E. (2019). The rural and peripheral in regional development: An alternative perspective. *Regional Studies*, 53(6), 924-925.
- [31] Wanner, A. Seier, G.& Pröbstl-Haider, U.(2020). Policies related to sustainable tourism – An assessment and comparison of European policies, frameworks and plans. *Journal of Outdoor Recreation and Tourism*. Vol.29 ref.48.1-12
- [32] Williams, A. M., & Baláz, V. (2001). From collective provision to commodification of tourism? *Annals of Tourism Research*, 28(1), 27–49.
- [33] Yachin, J. M., & Ioannides, D. (2020). “Making do” in rural tourism: the resourcing behaviour of tourism micro-firms. *Journal of Sustainable Tourism*, 28(7), 1003-1021.
- [34] Zhang, H. Q., Chong, K., & Ap, J. (1999). An analysis of tourism policy development in modern china. *Tourism Management*, 20(4), 471-485.
- [35] Zhang, J., & Zhang, Y. (2020). Examining the energy literacy of tourism peasant households in rural tourism destinations. *Asia Pacific Journal of Tourism Research*, 25(4), 441-456.
- [36] Zielinski, S., Kim, S., Botero, C. M., & Yanes, A. (2020). Factors that facilitate and inhibit community-based tourism initiatives in developing countries. *Current Issues in Tourism*, 23(6), 723-739.

Successful Features of Crowdfunding Campaigns: An Analysis of Requests for Coronavirus Food Relief

(Work in Progress)

Nan Zhao*, Wenzhou-Kean University, China, zhaona@kean.edu

Zhengqing Yuan, Wenzhou-Kean University, China, yuanzhe@kean.edu

Jiajie Zou, Wenzhou-Kean University, China, zouji@kean.edu

Candy Lim. Chiu, Wenzhou-Kean University, China, cchiu@kean.edu

Han-Chiang Ho, Wenzhou-Kean University, China, hho@kean.edu

Somkiat Mansumittrchai, Wenzhou-Kean University, China, smansumi@kean.edu

ABSTRACT

Crowdfunding is an emerging industry in the past decades, which proliferates and has attracted an enormous population from the public to be involved in various funding projects in multiple fields such as business entrepreneurship, healthcare, and fintech. Meanwhile, charitable crowdfunding platforms such as GoFundMe, Indiegogo, and Kickstarter have allowed internet users to provide help and donation to the fundraisers directly. As the year 2020 is surrounded by the COVID-19 global pandemic spreading out the world, the topic of coronavirus relief has surged. Thus, it is worthy of evaluating the crowdfunding campaign's effectiveness during the coronavirus context by making a connection between fundraising activities and coronavirus relief. This paper aims to investigate the effects of various factors affecting a donation-based crowdfunding campaign for coronavirus relief of food donation in the United States and determine the significant factors affecting the campaign's success rate.

To achieve this research purpose, secondary data were extensively collected from the crowdfunding platform GoFundMe for regression analysis. The sample data was derived from crowdfunding campaigns launched from March 1st, 2020, to May 31st, 2020. During this period, the United States was severely affected by the COVID-19 pandemic with an exponentially surged number of confirmed cases. This paper derives the independent variables that have been examined from previous studies and further applies in the coronavirus context to identify whether these factors are significant influencers to the success of crowdfunding campaigns for coronavirus relief of food donation. The factors being examined include target funding amount, the existence of spelling mistakes, the presence of pictures, video, social network sites, project updates, comments between fundraisers and backers, and links to external websites. That the significant factors contributing to a successful funding project are similar, as identified in previous reward-based and equity crowdfunding studies. On the other hand, several independent variables' effectiveness varied between the normal scenario and the coronavirus context, as such variables demonstrate a much compelling role to attract donors for the coronavirus relief activations.

The analysis is valuable and worthy of different viewpoints. First, understanding the donor's motivation and the success features of funding projects is valuable for fundraisers to have a strategic mindset for decision-making criteria when initiating funding projects to attract more donors and the amount of money. Second, because of the lack of literature focusing on examining the success features for donation-based crowdfunding campaigns, this study fills the gap and further focus on the crowdfunding activations in the context of coronavirus food relief in the US. Therefore, this study provides significant insight to understand the dynamics of the donation-based crowdfunding campaign and provides a recommendation to develop coronavirus relief more efficiently.

Keywords: Coronavirus, COVID-19, Pandemic, Food Relief, Food Donation, United States.

*Corresponding author

INTRODUCTION

Reported by the Centers for Disease Control and Prevention (CDC) as of September 12, 2020, there have been 6,427,058 confirmed COVID-19 infected cases and 192,388 deaths in the United States alone, which contribute to roughly 26% and 22% of the total number of cases worldwide respectively (CDC, 2020). Under such context, a large number of crowdfunding campaigns in different states in the U.S. have been initiated for coronavirus relief, such as medical and food relief, in response to the loss of income sources resulting from lockdown, temporary business closure, bankruptcies, lay-offs, and unemployment. Due to the crowdfunding platform's online accessibility, it becomes a powerful tool during the COVID-19 outbreak to help finance any treatment. Also, crowdfunding platforms are being leveraged to provide relief that will assist vulnerable people across the world.

Based on the study of Rajwa *et al.* (2020), they identified 1579 crowdfunding campaigns that are related to COVID-19 issues that were created on GoFundMe.com between March 3 and March 20, 2020, with a total fundraising goal of \$1,492,988,587. The number of campaigns continues to increase rapidly with the wide-spread of confirmed COVID-19 cases. Currently, research study about characteristics of equity crowdfunding campaign success is growing such as Ahlers *et al.* (2015), Lukkarinen *et al.* (2016), Agrawal *et al.* (2015), Kim and Viswanathan (2014), Cholakova and Clarysse (2015), and Bernstein *et al.* (2014). Lagazio and Querci (2018) have examined several key factors contributing to a successful reward-based crowdfunding campaign. However, Legazio and Querci's (2018) research is primarily based on reward-based crowdfunding projects launched by the Italian crowdfunding market while the situation in the United States may vary quite much, and the nature of the crowdfunding is mostly charity-based.

Due to the lack of literature on this type of crowdfunding campaigns, this study will fill the gap by focusing on the successful features of crowdfunding campaigns in the coronavirus food relief of food in the United States as the Covid-19 has dramatically overturned the country. This paper aims to investigate the effects of various features occurred during the crowdfunding campaign process, such as the campaign goal, campaign duration, spelling mistakes, storytelling, photos, video, social network, presence of updates and/or comments, and presence of links to external websites, in initiating a successful crowdfunding campaign for coronavirus food relief the United States.

LITERATURE REVIEW AND HYPOTHESIS DEVELOPMENT

Theoretical Framework

Success of the Campaign

Crowdfunding platforms can choose either the “all-or-nothing” model or “keep-it-all” model to run the platforms. In the “all-or-nothing” model, project owner receives the invested money only if the goal for minimum target funding is achieved. While project owner is able to keep any funds that the project collected under the “keep-it-all” model (Cumming *et al.*, 2014). In this paper, the campaign succeeds if the rate of financing (i.e., the ratio between project target and amount received at the end of the campaign) is higher than or equal to 100%. Thus, if the campaigner raises at least the pre-set target amount, the campaign is successful.

Altruism and the theory of warm-glow giving (Andreoni, 1990)

According to Crumpler and Grossman (2008), the theory of warm-glow giving can be defined as an individual who is presented with the opportunity to contribute to charity and society. Altruism and the theory of warm-glow identifies that people will gain a sense of utility from the act of giving and donation (Andreoni, 1990). This theory explains the donor's motivation when participating in the relief donation project such as the crowdfunding campaign: that is, donors can not only contribute themselves to the social relief project but also achieve significant social impacts in helping those from a disadvantaged background as the response to the global pandemic situation. Therefore, this theory can contribute to the successful features of crowdfunding campaigns because the social impact is an important factor affecting donor's motivation of campaign initiatives.

Narrative theories on persuasion and information processing (Stern, 1991)

Stern (1991) introduced the theory by identifying the narrative as a medium to guide human behaviors. Various messaging strategies could be set up for narrative with the target audience, including media patterns and user appeals with visual or textual communication. The impacts on human behaviors vary based on the type of persuasion and informative strategy applied within the medium of the narrative. In the crowdfunding campaigns within the coronavirus context, the persuasiveness of information provided to the target donors is thus a vital factor to the success of the project. Besides, the video, verbal, and audio elements occurred in the communication are critical measurements to the narrative theories (Lagazio & Querci, 2018). Linked to the coronavirus relief crowdfunding campaigns, this theory could effectively interpret the presentation of the campaign through its content, message, video, and other relevant channels, which play a critical rule in examining the successful features of the projects.

Presence of pictures or video

A vivid presentation using audio elements, visuals (e.g., image, infographics, and animation) stimulates various sensory channels that are appealing to the audience or backers (Kunz *et al.*, 2016). The use of images and videos in the crowdfunding campaign enhances media richness in online communication (Courtney, Dutta, & Li, 2017), and emotions can be communicated more easily (Clauss *et al.*, 2018). A descriptive text provides detailed explanations of the project, whereas a video concisely outlines a project (Lagazio & Querci, 2018). The campaign's storytelling in a visual form rather than text-only messages leads to successfully funded projects (Colombo *et al.*, 2015; Huang *et al.*, 2018). Therefore, we hypothesize:

H2: The presence of picture will have a significant influence on the crowdfunding campaign success

H3: The presence of video will have a significant influence on the crowdfunding campaign success

Social identity theory (Tajfel et al., 1979)

Tajef *et al.* (1979) suggested that the social identity theory is the representation of individuals who regard themselves as members of the group when performing for the social identity. Besides, the groups that individuals belong to are crucial sources of self-esteem and recognition. Lagazio and Querci (2018) noted that the social identity theory would be practical when potential donors are sharing the crowdfunding campaigns over social networks with high exposure to project awareness. Thus, the social identity theory could link to the successful features of crowdfunding campaigns within the context of intense interaction between donors and fundraisers.

Attainable Target Fund

The funding goal of crowdfunding campaigns has a significant influence on potential backers' decision on the amount that will be donated or invested (Kuppuswamy & Bayus, 2017). Hobbs *et al.* (2016) illustrate that fundraisers must balance the budgetary requirements and the likelihood of achieving targets while setting project goals. Donation-based crowdfunding projects have a wide variety of goals. Many donation campaigns seek to raise small amounts of donation, often between US\$1000 to US\$5000, to initiate a particular one-time relief. Overambitious funding targets of crowdfunding campaigns reduce the chance of success or raising no funds at all (Mollick 2014; Liu & Liu 2016; Lagazio & Querci 2018; Kuppuswamy & Bayus, 2018). Lagazio and Querci (2018) demonstrate that fixed campaigns with clear goals and precise targets have a higher rate of success than flexible campaigns by an 11 % success rate. Therefore, we hypothesize:

H4: An attainable target fund will have a significant influence on the crowdfunding campaign success

Signaling theory (Ross, 1977; Spence, 1973)

Ross (1977) and Spence (1973) suggested in their literature of signaling theory that entrepreneurial activities are highly related to the degree of information possession by other parties. In this theory, one party will determine how to communicate and signal the information while the other party will decide how to interpret this sort of information. Connelly *et al.* (2011) further pointed out that the signaling theory can help identify behaviors when both parties of individuals have access to different information. Therefore, this theory also has a close-knit relationship to the success features of coronavirus relief crowdfunding campaign, which are highly dependent on the effectiveness of the message conveyed from the fundraiser to donor regarding whether the information accessed by both parties is consistent for the campaign initiatives.

Presence of project updates

Prior studies found that providing updates to funders can increase funding success. Fundraisers can communicate with their supporters by posting updates on their projects that everyone can see. According to Block, Hornuf, and Moritz (2017), providing updates is a one-sided communication for capital seekers to provide additional information about their business ideas, products, start-up's value, or the campaign. Mollick (2014) stated that for campaigns to generate visibility, fundraisers are highly recommended to update their project because the absence of an update reduces the chance of success by 13%. Successful crowdfunding projects can achieve higher project support levels if the fundraisers communicate more to the potential contributors and their backers by posting more updates. Lagazio and Querci (2018) 's findings show that an updated crowdfunding campaign page is much more appealing, instills trust, increases the sense of involvement of the contributors, and provides opportunities to recommend to new followers. Hence, it increases the probability of success by 5%. Based on previous findings, we propose:

H6: The presence of project updates will have a significant influence on the crowdfunding campaign success

Presence of comments between fundraiser and backers

Fundraiser's comments induce backers to participate because it enables direct conversation, especially if it contains valuable feedback or information about the crowdfunding project (Hornuf & Schwienbacher, 2015). Kromidha and Robson (2016) stated that an engaging joint forum between the fundraiser and its backers can achieve a greater pledge/backer ratio. Courtney, Dutta, and Li (2017) prove the relevance of backers' comments, which serve as a third-party endorsement of the project quality and the fundraiser's credibility. The study of Wang *et al.* (2018) shows the importance of interaction between capital seekers and backers in crowdfunding success, including the number of comments, comment sentiments, length of response, and reply speed. It shows that the fundraisers is willing to invest considerable time and effort to address concerns and shows gratefulness for donors. Hence, we hypothesize:

H7: The presence of comments between fundraiser and backers will have a significant influence on the crowdfunding campaign success

Presence of links to external websites

Lagazio and Querci (2018) argue that fund seekers must give all information needed, such as links to external websites, to help the backers in his/her decision-making with the presence of information asymmetry. External websites provide more detailed and additional information about the project and the fundraisers that can generate traffic to the fundraiser's homepage and enhance communication with stakeholders and increase trust because it signals transparency (Dikaputra, Sulung, & Kot, 2019). Potential backers are usually restricted to the available information from the crowdfunding website; links to external websites can therefore increase the functionalities of communicating with the public (Kunz *et al.*, 2016). Fundraisers can customize the design for project presentations, especially for target donors without social media. Therefore, having a link to an external

website may lead to an increased probability of project success. The presence of links is also highly relevant to the signaling theory as identified above. As supplementary information is identified at the outside link, the donor could perceive a better overview of the project as the effectiveness of interpretation for the information in the project is enhanced by both parties. We hypothesize:

H8: The presence of links to external websites will have a significant influence on the crowdfunding campaign success

Based on the literature and theoretical framework discussed above, this study proposes a conceptual model as shown in Figure 1.

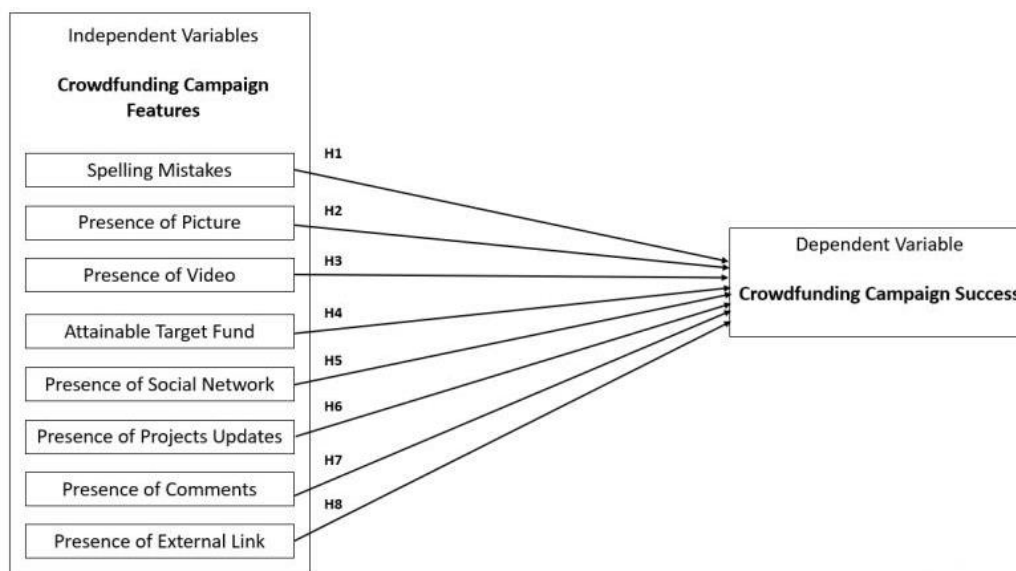

Source: This study.

Figure 1: Conceptual Framework

CONCLUSION

The analysis is valuable and meritorious from different viewpoints. First, understanding the donor's motivation and the success features of funding projects is valuable for fundraisers to have a strategic mindset for decision-making criteria when initiating funding projects to attract more donors and amount of money. Second, it is important to fill the gap about the analysis of successful features of a crowdfunding campaign in the coronavirus context since the pandemic has significantly affected the order of the world and it is urgent to have a better understanding of this issue to develop coronavirus relief more efficiently.

REFERENCES

- [1] Alonso Dos Santos, M., Lobos, C., Muñoz, N., Romero, D., & Sanhueza, R. (2017). The influence of image valence on the attention paid to charity advertising. *Journal of Nonprofit & Public Sector Marketing*, 29(3), 346-363.
- [2] Block, J., Hornuf, L. and Moritz, A. (2017). Which updates during an equity crowdfunding campaign increase crowd participation? *Small Business Economics*, 50(4), 3–27.
- [3] Clauss, T., Breitenecker, R. J., Kraus, S., Brem, A. and Richter, C. (2018). Directing the wisdom of the crowd: the importance of social interaction among founders and the crowd during crowdfunding campaigns. *Economics of Innovation and New Technology*, 27(8), 709-729.
- [4] Colombo, M. G., Franzoni, C. and Rossi-Lamastra, C. (2015). Internal social capital and the attraction of early contributions in crowdfunding. *Entrepreneurship Theory and Practice*, 39(1), 75-100.
- [5] Courtney, C., Dutta, S. and Li, Y. (2017). Resolving information asymmetry: Signaling, endorsement, and crowdfunding success. *Entrepreneurship Theory and Practice*, 41(2), 265–290.
- [6] Cryder, C. E., Loewenstein, G., & Scheines, R. (2013). The donor is in the details. *Organizational Behavior and Human Decision Processes*, 120(1), 15-23.
- [7] Dikaputra, R., Sulung, L. A. K., & Kot, S. (2019). Analysis of Success Factors of Reward-Based Crowdfunding Campaigns Using Multi-Theory Approach in ASEAN-5 Countries. *Social Sciences*, 8(10), 293.
- [8] Wang, J. G., Xu, H., Ma, J., Zhang, Y., & Chen, Z. (Eds.). (2017). *Financing from Masses: Crowdfunding in China*. Springer.
- [9] Gleasure, R. and Morgan, L. (2017). The pastoral crowd: Exploring self-hosted crowdfunding using activity theory and social capital. *Information Systems Journal*, 28(3), 489-515.
- [10] Hobbs, J., Grigore, G. and Molesworth, M. (2016). Success in the management of crowdfunding projects in the creative industries. *Internet Research*, 26(1), 146-166.

- [11] Huang, Z., Chiu, C. L., Mo, S., & Marjerison, R. (2018). The nature of crowdfunding in China: initial evidence. *Asia Pacific Journal of Innovation and Entrepreneurship*, 12(3), 300-322.
- [12] Kromidha, E., & Robson, P. (2016). Social identity and signalling success factors in online crowdfunding. *Entrepreneurship & Regional Development*, 28(9-10), 605-629.
- [13] Kunz, M. M.; Bretschneider, U.; Erler, M. and Leimeister, J. M. (2016). An Empirical Investigation of Signaling in Reward-Based Crowdfunding. *Electronic Commerce Research*, 17(5), 425-461.
- [14] Kuppuswamy, V., & Bayus, B. L. (2017). Does my contribution to your crowdfunding project matter? *Journal of Business Venturing*, 32(1), 72-89.
- [15] Kuppuswamy, V., & Bayus, B. L. (2018). Crowdfunding creative ideas: The dynamics of project backers. In *The Economics of Crowdfunding* (pp. 151-182). Palgrave Macmillan, Cham.
- [16] Lagazio, C., & Querci, F. (2018). Exploring the multi-sided nature of crowdfunding campaign success. *Journal of Business Research*, 90, 318-324.
- [17] Liu, C. and Liu, J. S., (2016). Antecedents of Success Rate of Award-Based Crowdfunding: The Case of the 'Kickstarter'. *Modern Economy*, 7(3), 250-261.
- [18] Lu, C. T., Xie, S., Kong, X. and Yu, P. S. (2014). Inferring the impacts of social media on crowdfunding. In *Proceedings of the 7th ACM International Conference on Web Search and Data Mining*, 573-582.
- [19] Lukkarinen, A., Teich, J. E., Wallenius, H. and Wallenius, J. (2016). Success drivers of online equity crowdfunding campaigns. *Decision Support Systems*, 87, 26–38.
- [20] Mollick, E. (2014). The dynamics of crowdfunding: An exploratory study. *Journal of Business Venturing*, 29(1), 1-16.
- [21] Righi, R. R., Alberti, M. A. and Singh, M. (2020). *Blockchain-Based Crowdfunding*, Springer, Singapore.
- [22] Sheng, B., Liu, Z. and Usman, K. (2017). The influence of online information on investing decisions of reward-based crowdfunding. *Journal Business Research*, 71, 10–18.
- [23] Sulaeman, D. (2018). Smart charities? Analyses of IT-enabled charitable fundraising. *PACIS 2018 Proceedings*, 340.
- [24] Zheng, H., Li, D., Wu, J., & Xu, Y. (2014). The role of multidimensional social capital in crowdfunding: A comparative study in China and US. *Information & Management*, 51(4), 488-496.

The Continuous Use Intentions and Antecedents of Novice Players in the Social Network Online Games

(Work in Progress)

Wei-Hsi Hung, National Chengchi University, Taiwan, fhung@nccu.edu.tw

Kai-Ju Chuang*, National Chengchi University, Taiwan, Hsuan Chuang University, Taiwan, karen999k@gmail.com

ABSTRACT

Social network online games (SNOGs) make players have a positive usage status (such as: entertainment, and enjoyment). Yet, it may also produce a negative usage status (such as: technostress). Users who are new to social network online games are termed novice gamers. Based on the theory of Technological-Personal-Environmental (TPE), this research proposes a framework to explain the adoption of social network online games from the novice players' perspective, and conducts qualitative in-depth interviews with them to define the key factors for the continuous usage intention on social network online games. This research plans to use online questionnaires and structural equation modeling (SEM) to verify models and hypotheses in order to obtain antecedents of the continuous usage intention for novice players in social network online games and related impact.

Keywords: Social network online game, novice user, expert user, continuous use intention

*Corresponding author

INTRODUCTION

With the advancement of technology, smart phones have become people's platform for entertainment and social interaction. According to relevant analysis of Newzoo, the benchmarking platform for global game market data analysis has revealed several key finding (Newzoo, 2020; 199IT.COM, 2020; Wijman, 2020). Firstly, by the end of 2020, there will be 2.7 billion gamers in the world, and the number of gamers worldwide will continue to grow. Secondly, among global gamers, 2.5 billion plays mobile games, 1.3 billion plays PC-based games, and 80 million plays console games. Thirdly, the global games market revenue will reach 159.3 billion US dollars in 2020. The Asia-Pacific region is the largest market, in 2020, games revenue will reach 78.4 billion US dollars, an annual growth of 9.3%, accounting for half of global game revenue. Fourthly, mobile games (including smartphone games and tablet games) are the largest market, generating \$77.2 billion in revenue. Lastly, many players in these emerging markets are entering games through mobile devices. In the future, games are likely to become new social media platforms, and they may also bring new business models to the next generation. From the perspective of game revenue structure, mobile games also continue to grow in the market and become the dominant player in the gaming industry.

Over the past decade, computers and mobile games have become one of the mainstream cultures in the lives of young people. Today based on games' social interaction uniqueness, people can create a unified interest, goals, and experiences that can connect each other together while at the same time, the gaming world as a whole is more immersive than social applications, and the feedback of games is often more instantaneous, satisfying, interactive, and fun than social media alone. Therefore, young people are shifting from social media to video games that provide better interactive experiences (Newzoo, 2020).

Game feature is one of the characteristics of smart phones. Users will experience immersion (Ha, Yoon, & Choi, 2007) and a sense of pleasure when playing mobile games. This experience allows players to revisit the same game again and again, so that users get drawn to it (Shin & Kim, 2008). Since social games have a large number of players, the users who entertain themselves at the same time have created the technological pressure of social games, and at the same time caused negative psychological states (such as technostress or addiction).

In the past, most of the factors related to technological acceptance were the TOE (Technology-Organization-Environment) framework proposed by Tornatzky and Fleischer (1990), which was the most widely accepted. Due to the relevant factors contained in the existing TOE framework, the current academic situation cannot fully meet the needs of research in terms of the user behavior of mobile social network players. Therefore, this research refers to the TPE (Technological-Personal-Environmental) model classification proposed by Jiang, Chen, and Lai (2010), and converts the TOE architecture into a personal usage model, which are respectively the Technological Context, Personal Context, and Environmental Context and other three categories, make the extension of TOE mode more complete. This research is based on the TPE framework to explore the continuous use intentions and related influences of the novice player group in the context of social network online games (SNOGs).

LITERATURE REVIEW

Social Network Game

Gaming is regarded as a way of relaxation and leisure, and as society has evolved into digital games, the popularity of digital games has evolved into a communication medium used by millions of people (Terlutter & Capella, 2013). Shin and Shin (2011) defined social network online games as multiplayer games, with one or more functions, and a casual social platform that provides a person with a role and identity. Social games use existing social networks and platforms, such as smart phones to share with friends. The difference between social network games and general games is that they pay attention to the connection between friends, is convenient and can bring entertainment, so it has become a trend.

Wang and Lee (2020) define Mobile Social Network Games (MSNGs) as a product that combines games and social network services (SNSs), and they also believe that this type of game mechanism provides players with more fun and establishes a strong social atmosphere through competition or cooperation modes.

Due to the development of technology and the popularization of the Internet, online network games have the characteristics of real-time, five-sense experiences, media, interaction, and social, which have driven the trend of social network games. These have formed a large number of game players. Compared with stand-alone games, online network games can bring more social interactions, expand interpersonal relationships, and bring more entertainments, but frequent use can easily lead to friction and pressure.

Continue Use Intention

Bhattacharjee (2001) investigates the consistency between the decision of individuals to continue using information technology and the decision of consumers to repeat purchases, and proposes to use the expectation confirmation theory in the scientific literature as a theoretical basis to explain the user's intention to continual use. He proposes an expectation-confirmation model, with continuance intention as the contingency number.

Other studies have tried to integrate theories or models to explain the users' intention to continue using information technology. From the perspective of social capital theory, Hsiao and Chiou (2012) studied the Massive Multiplayer Online Game (MMOG) in the context of a community to explore how to influence personal attitudes and continued use intentions. Wang *et al.* (2020) used perceived entertainment and concentration as intermediary variables to explore the continuous use intention of mobile social network games (MSNGs). The result shows that perceived entertainment and concentration have a significant positive impact on continued use intentions.

However, on the other hand, Tarafdar *et al.* (2020) believe that the use of Information Technology (IT) may become a source of stress, namely, technostress, for people to adopt certain technological applications. It also explores the relationship between technostress and technological addiction caused by people adopting social networking sites. This study pointed out that even if people find that they are exhausted and unable to keep up and responding to (posts) on social networking sites, it is still difficult for people to leave the use of social networking sites. Even when individuals are stressed by using social networking sites, they may continue to be addicted to the same social networking sites.

TPE Framework

Jiang *et al.* (2010) referred to numerous TOE theories related documents, and proposed that the factors affecting the adoption of personal information technology are classified according to the TPE (Technological-Personal-Environmental) model, which are divided into three categories: technology, personal, and environment. The meanings are explained as follows:

1. Technology Context: It contains many factors. Taylor and Todd (1995) studied the use of information technology by individuals and found that self-efficacy has an impact on perceived behavior control, which in turn affects the users' behavior intentions and usage behavior. Hackbarth, Grover and Yi (2003) pointed out that entertainment and technostress are considered to be systematic experiences that have a significant mediating effect on perceived ease of use.
2. Personal Context: Contains many factors, such as personal-related content that will affect the choice of information technology, including personal personality and other personal characteristics and other related attributes, such as: extraversion and risk aversion. Related research has pointed out that personality traits affect the choice of information technology (Korzaan & Boswell, 2008).
3. Entertainment Context: It contains many factors. The environmental aspect refers to the mutual relationship between individuals in a social group environment, such as interpersonal relationships. The common theory in the environment is the system theory, that is, group pressure, which is a personal belief, attitude and behavior that will be affected by the system (Emdad, Badamass & Mouakket, 2009; Scott, 2001).

Novice IT Users

This research focuses on social network online games. In 1991, Mackay and Lamb divided web users into three categories based on their experiences, namely novice, intermediate and expert.

In this research the author summarizes previous research on human-computer interaction and the key to successful technological development, with analyzation by user type, as shown in Table 1.

The study adopts Mackay and Lamb in 1991 for the type of web users, and defines a novice as having used the game software but not using it frequently nor is specialized. That is, the beginner himself has no experience with the game and cannot immediately master the situation of the game. Even using it once is also considered as a novice.

Table 1. User Types

Year	Author	User Type
1991	Mackay and Lamb (1991)	novice, intermediate and expert
2000	Dreyfus and Dreyfus (2000)	Novice, Advanced beginner, Competent, Proficient and Expert
2003	Hackbarth <i>et al.</i> (2003)	novice, intermediate and expert
2010	Brandtzæg (2010)	No use, Low use, Medium use and High use

Source: This study.

RESEARCH METHOD

Research Design and Research Objects

The study explores the antecedents that affect the continuous use of social network online games, the use status, the causal relationship between continuous use intent and various variables, and then classifies and organizes them to provide an integrated antecedent framework to understand the relationship between various motivations and users' continued use of social network online games. Since none of the previous studies has proposed an integrated framework and concept, the design of this research first focuses on the group of young users of social network online games as the main analysis object.

The research design is expected to adopt a two-stage data collection. The first stage is the literature review. After exploration, the research category will be proposed, and the continuous use intention of the social network online games for novice group is summarized, the key influence antecedents in the TPE dimension are defined, and the novice group is also targeted (a total of 20 people) to conduct qualitative interviews and to be compared with literature-based methods.

After this research has gone through the aforementioned process, the propositions of this research category and the interview results are obtained. It is expected that the second phase of quantitative research and analysis will be carried out next to verify the relevant antecedents, propositions and hypotheses of the continuous use intentions of novice players in social network online games. The question items will be developed first, followed by online questionnaire survey, data analysis, SEM structural equations and model verification, and then conduct qualitative and quantitative research results summary, comparison and analysis, and it is expected that conclusions and suggestions will be put forward to define academic contributions and research observations on the current development of the industry.

PROPOSITIONS

In this study, we plan to conduct interviews for novice group. The results of the interview will be generated by using grounded theory to find out the various variables that influence the continuous use intention of the TPE dimension.

Models and Propositions

The research revises the TPE model proposed by Jiang *et al.*, (2010), and divides the impact on the use of information technology into three major aspects: technology, personal, and environment. It also refers to related past research, and then establishes the proposition of social network online games in this research, then proposes a social game model: "the model of the continuous use intention of the novice group" (please refer to Figure 1).

Proposition Regarding the Continuous Use Intention of the Novice Group of Social Network Game Players

Hackbarth *et al.* (2003) pointed out that many studies have shown that: in the initial stage of using a computer system, many users will have anxiety. The results of the study show that the user's system experience will affect the individual's entertainment of the system. Beaudry and Pinsonneault (2010) believe that few people pay attention to understanding how

emotions affect the initial use of information systems. The increase in technological anxiety will greatly reduce the satisfaction of interacting with information technology, and affect the intention of using information technology, especially for novices and initial users. This study found that variable such as novices' experience of using the system, perceived ease of use, self-efficacy, etc., will all affect the state of use. However, there are still some points that can be clarified in the existing research results on the network online games of the novice community. Based on the above discussion, this research has compiled the following propositions (please refer to Figure 1):

Proposition: In social network online games, the variables in the TPE dimension have a significant impact on the game usage status of novice players

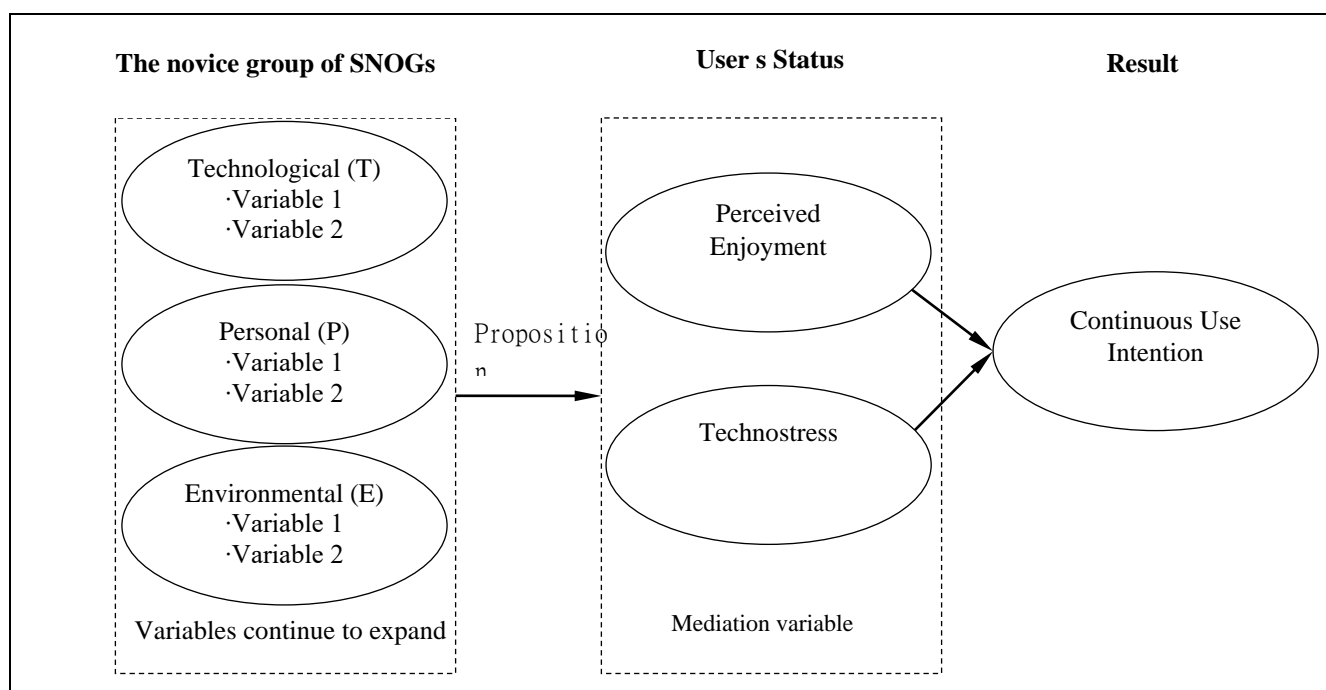

Source: This study.

Figure 1: The preliminary model of continuous use intention of the novice group of social network online online games

CONTRIBUTIONS AND FUTURE RESEARCH

The study draws various relevant comments and analyses of experts and scholars on the research field from the literature discussion, including social network online games, the antecedents of technology adoption, continuous use intentions, the transition from TOE to TPE, etc.

At this stage, the research draws the conclusion from literature review. Future research may employ in-depth interviews, grounding methods, and research observations to identify what novice's user of social network online games are interested in using new technologies. The relevant variables classified by the TPE dimensions include 3 levels, i.e., Technology level: perceived usefulness, perceived ease of use, self-efficacy; Personal level: compatibility, extraversion, risk appetite and Environmental level: institutional pressures, imitation behavior, Social Influence... and other variables. Although these variables correspond to entertainment and technostress, they may have different levels of impact on continuous use intention.

The design of this research is expected to adopt a variety of research methods (document comparison method, grounded method, interview method, survey method, SEM, etc.) for research analysis and comparison, and conduct two-stage qualitative research method and quantitative research method. The research results will be analyzed and compared to derive more in-depth research findings. It is hoped that after a scientifically proven research process, relevant research results can be obtained and analyzed and discussed.

REFERENCES

- [1] 199IT.COM (2020). Global Games Market Report. (in Chinese) Retrieved from <http://www.199it.com/archives/1082336.html> (13 August 2020)
- [2] Beaudry, A., & Pinsonneault, A. (2010). The other side of acceptance: studying the direct and indirect effects of

- emotions on information technology use. *MIS Quarterly*, 34(4), 689-710.
- [3] Bhattacharjee, A. (2001). Understanding information systems continuance: an expectation-confirmation model. *MIS Quarterly*, 25(3), 351-370.
- [4] Brandtzæg, P. B. (2010). Towards a unified Media-User Typology (MUT): A meta-analysis and review of the research literature on media-user typologies. *Computers in Human Behavior*, 26(5), 940-956. <https://doi.org/10.1016/j.chb.2010.02.008>.
- [5] Dreyfus, H., & Dreyfus, S. E. (2000). *Mind Over Machine*. New York: The Free Press.
- [6] Sodano, D. (2016). Mobile Taiwan: A look at a highly mobile market. *Insider Intelligence-eMarketer*. Retrieved from <https://www.emarketer.com/Article/Mobile-Taiwan-Look-Highly-Mobile-Market/1014877?ecid=NL1007>. (13 August, 2020)
- [7] Emdad, A. F., Badamas, M., & Mouakket, S. (2009). Factors and impacts of low utilization of Internet: The case of Arab countries. *Journal of International Technology and Information Management*, 18(3), 299-320.
- [8] Ha, I., Yoon, Y., & Choi, M. (2007). Determinants of adoption of mobile games under mobile broadband wireless access environment. *Information & Management*, 44(3), 276-286.
- [9] Hackbarth, G., Grover, V., & Mun, Y. Y. (2003). Computer playfulness and anxiety: positive and negative mediators of the system experience effect on perceived ease of use. *Information & Management*, 40(3), 221-232.
- [10] Hsiao, C. C., & Chiou, J. S. (2012). The effects of a player's network centrality on resource accessibility, game enjoyment, and continuance intention: A study on online gaming communities. *Electronic Commerce Research and Applications*, 11(1), 75-84.
- [11] Jiang, Y., Chen, D., & Lai, F. (2010). Technological-personal-environmental (TPE) framework: A conceptual model for technology acceptance at the individual level. *Journal of International Technology and Information Management*, 19(3), 89-98.
- [12] Korzaan, M. L., & Boswell, K. T. (2008). The influence of personality traits and information privacy concerns on behavioral intentions. *Journal of Computer Information Systems*, 48(4), 15-24.
- [13] Mackay, J. M., & Lamb Jr., C. W. (1991). Training needs of novices and experts with referent experience and task domain knowledge. *Information & Management*, 20(3), 183-189.
- [14] Newzoo (2020). *Global Games Market Report*. From <https://newzoo.com/products/reports/global-esports-market-report/> (12 August 2020)
- [15] Scott, W. R. (2001). *Institutions and Organizations*. Thousand Oaks, CA; Sage.
- [16] Shin, D. H., & Kim, W. Y. (2008). Applying the technology acceptance model and flow theory to cyworld user behavior: implication of the web2.0 user acceptance. *CyberPsychology & Behavior*, 11(3), 378-382.
- [17] Shin, D. H., & Shin, Y. J. (2011). Why do people play social network games? *Computers in Human Behavior*, 27(2), 852-861.
- [18] Tarafdar, M., Maier, C., Laumer, S., & Weitzel, T. (2020). Explaining the link between technostress and technology addiction for social networking sites: A study of distraction as a coping behavior. *Information Systems Journal*, 30(1), 96-124. DOI: 10.1111/isj.12253
- [19] Taylor, S., & Todd, P. A. (1995). Understanding information technology usage: A test of competing models. *Information Systems Research*, 6(2), 144-176.
- [20] Terlutter, R., & Capella, M. L. (2013). The gamification of advertising: analysis and research directions of in-game advertising, advergames, and advertising in social network games. *Journal of Advertising*, 42(2-3), 95-112.
- [21] Tornatzky, L.G., & Fleischer, M. (1990). *The Processes of Technological Innovation*. Massachusetts: Lexington.
- [22] Wang, H., & Lee, K. (2020). Getting in the flow together: The role of social presence, perceived enjoyment and concentration on sustainable use intention of mobile social network game. *Sustainability*, 12(17), 6853. DOI: 10.3390/su12176853
- [23] Wijman, T. (2020). Newzoo released the "2020 Global Games Market Report": Global game players will reach 3 billion by 2023, player participation and industry revenue will continue to rise. (in Chinese) Retrieved from <https://newzoo.com/insights/articles/games-market-revenues-engagement-trends-2020-2023-gaming-report-chinese/> (13 August 2020).

Tseng, T. (2020). Lessons of COVID-19 pandemic on cross-border e-commerce and suggestions. In *Proceedings of The 20th International Conference on Electronic Business* (p. 506). ICEB'20, Hong Kong SAR, China, December 5-8.

Lessons of COVID-19 Pandemic on Cross-border E-commerce and Suggestions

(Abstract)

TzuShan Tseng, Ming Chuan University, FlyinPop, Ltd., Taiwan,
shan23tw@yahoo.com.tw.

ABSTRACT

COVID-19 pandemic has become a worldwide crisis. A lot of known brands have been forced to shut down their physical stores. At the same time, the contact-free economy is rising and cross-border e-commerce sales have increased a lot. Due to closed borders restricting logistics and employees limited to home for quarantine, some negative effects on cross-border e-commerce companies have arisen. Many companies are finding themselves in troubles because, for example, they cannot get the components or/and goods they need. The COVID 19 crisis is a world-changing event, and the pandemic is not yet over. It is impossible to know what will happen in the future, but it is possible to consider the lessons from the COVID-19 pandemic, and on this basis, to think constructively about the future. This is the main research purpose for this study.

This study aims at examining lessons from the COVID-19 pandemic on cross-border e-commerce and then providing suggestions from those lessons. The research methodology adopted secondary data analysis and in-depth interviews to acquire the research results. The secondary data was collected from 2 global data and research companies, comprising eMarketer, and Quest Mobile, especially their white papers. Using secondary data may alone may not adequately fit the research purpose; so, primary in-depth interviews were conducted with cross-border e-commerce company leaders in Taiwan. After analyzing the collected data, several lessons from COVID-19 regarding cross-border e-commerce are discussed and then suggestions are presented for facing the “new normal” in this global pandemic period. The lessons included in the discussion are on supply chain, logistics, diversified customers and consumer experience. Suggestions are provided for each of them.

Keywords: Pandemic, COVID-19, cross-border e-commerce, supply chain disruption, logistics delays.