



# Proceedings of The International Conference on Electronic Business *Volume 23*

Edited by

**Eldon Y. Li**  
**She-I Chang**  
**Benjamin Yen**

**ICEB'23**  
**Chiayi, Taiwan**  
**19-23 October 2023**

**ISSN: 1683-0040**





**Proceedings of  
The International Conference on  
Electronic Business  
*Volume 23***

*“AI and Precision Analytics in Financial and  
Medical Services”*

Edited by

**Eldon Y. Li**

National Chung Cheng University

**She-I Chang**

National Chung Cheng University

**Benjamin Yen**

University of Hong Kong Business School

***ICEB'23***

Chiayi, Taiwan

19-23 October 2023

**ISSN: 1683-0040**

Reference to this book should be made as follows: Li, E.Y. *et al.* Eds. (2023). *Proceedings of The International Conference on Electronic Business, Volume 23* (ISSN: 1683-0040). ICEB'23, Chiayi, Taiwan, October 19-23, 2023, 778 pages.





Chengqi (John) Guo	James Madison University, USA
Chien-Ming Chen	Harbin Institute of Technology Shenzhen Campus, China
Chi-Ping Wei	National Taiwan University, Taipei, Taiwan
Chong Guan	Singapore University of Social Sciences, Singapore
Christy Cheung	Hong Kong Baptist University, Hong Kong
Eldon Y. Li	National Chung Cheng University, Chiayi, Taiwan
Feng Li	Cass Business School, City, University of London, UK
Honglei Li	Northumbria University, UK
Hsin-Lu Chang	National Chengchi University, Taipei, Taiwan
Hu Xiong	University of Science and Technology of China
Ibrahim M. Al-Jabri	King Fahd U. of Petroleum and Minerals, Saudi Arabia
Jao-Hong Cheng	National Yulin U. of Science and Technology, Taiwan
Jesús Garcia-Madariaga	Universidad Complutense de Madrid, Spain
Jia Qiong	Business School, Hohai University, Nanjing, China
Jiahua Weng	Kanagawa University, Yokohama, Japan
John Hamilton	James Cook University, Australia
Keng Leng Siau	City University of Hong Kong, Hong Kong
Kevin K.W. Ho	University of Tsukuba, Japan
Laddawan Kaewkitipong	Thammasat Business School, Thailand
Laurence F.K. Chang	Fang Chia University, Taichung, Taiwan
Liming Yao	Sichuan University, Chengdu, China
Michael C.L. Chau	University of Hong Kong, China
Michel De Rougemont	University Paris II, France
Pei-Lee Teh	Monash University, Malaysia
Peter Ractham	Thammasat University, Thailand
Pimmanee Rattanawicha	Chulalongkorn University, Thailand
Qiang Ye	University of Science and Technology of China
Ravi S. Sharma	Zayed University, Abu Dhabi, UAE
Savvas Papagiannidis	Newcastle University, UK
She-I Chang	National Chung Cheng University, Chiayi, Taiwan
Shih-Wei Liao	National Taiwan University, Taipei, Taiwan
Siriluck Rotchanakitumnuai	Thammasat University, Thailand
Stuart Orr	Melbourne Institute of Technology, Australia
Thurasamy Ramayah	Universiti Sains Malaysia
Timon C. Du	Chinese University of Hong Kong, China
Vandana Ahuja	Amity Business School, India
Victor Jeng-Chung Chen	National Cheng Kung University, Tainan, Taiwan
Waiman Cheung	Chinese University of Hong Kong, China
Wayne Huang	Southern University of Science and Technology, China
Wei-Hsi (Frank) Hung	National Chengchi University, Taipei, Taiwan
William Y.C. Wang	University of Waikato, New Zealand
Xiaoyu Xu	Xi'an Jiaotong University, China
Xudong (David) Luo	Guanxi Normal University, China
Yichuan Wang	Sheffield University Management School, UK
Yue Guo	Southern University of Science and Technology, China
Zhibin Lin	Durham University Business School, Durham, UK



# SPONSORING JOURNALS

---



*Journal of  
Business and  
Management*

Indexed by  
Australian ABDC list  
Cabell's whitelist  
EBSCO  
Google Scholar  
etc.



*International Journal of  
Electronic  
Business*

Indexed by  
Australian ABDC list  
Cabell's whitelist  
EI Compendex  
SCOPUS  
etc.



*International Journal of  
Internet Marketing and  
Advertising*

Indexed by  
Australian ABDC list  
Cabell's whitelist  
ESCI  
SCOPUS  
etc.

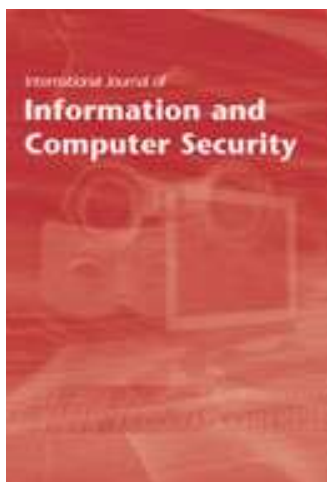

*International Journal of  
Information and  
Computer Security*

Indexed by  
Australian ERA list  
Cabell's whitelist  
EI Compendex  
SCOPUS  
etc.

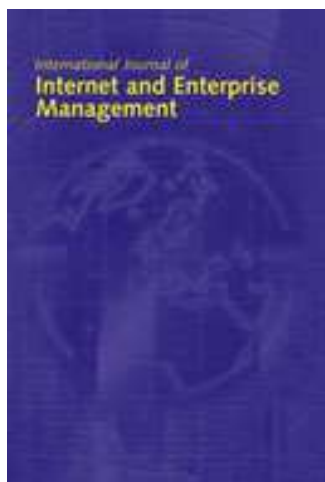

*International Journal of  
Internet and Enterprise  
Management*

Indexed by  
Australian ABDC list  
Cabell's whitelist  
Google Scholar  
ProQuest  
etc.

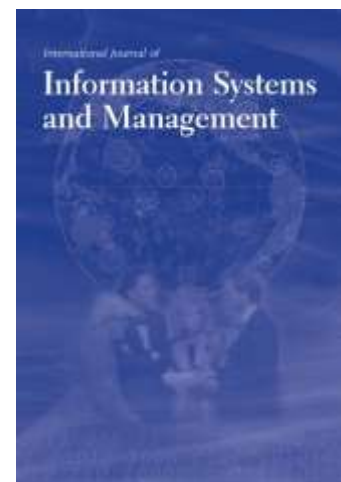

*International Journal of  
Information Systems  
and Management*

Indexed by  
ACM Digital Library  
Cabell's whitelist  
Google Scholar  
ProQuest  
etc.

# PREFACE

---

Welcome to the 23<sup>rd</sup> International Conference on Electronic Business (ICEB 2023). The conference this year is held virtually by the University of Hong Kong Business School and physically by the National Chung Cheng University Management College in Chiayi, Taiwan. The conference theme is “AI and Precision Analytics in Financial and Medical Services”. We received 115 submissions, and 96 papers were accepted into the final program, which consisted of 24 sessions. The topic areas of the papers in this conference include AI and its applications, Big data analytics and precision analytics, Blockchain and FinTech, Digital marketing and consumer behavior, Digital transformations in enterprises, EB models and issues, E-business education and e-learning, E-business strategies and models, E-healthcare and gerontechnology, IT ethics and data governance, New technology adoption and diffusion, Social media and social computing, Supply chain management and e-logistics, and other interdisciplinary issues. In this post-conference proceedings book, 80 papers are included: 63 full papers and 17 work-in-progress papers.



At the conference, we have scheduled seven keynote speakers which broke the record of every academic conferences in the world. The speakers include (in the appearance sequence): Prof. H. Kenny Cheng, a Senior Editor of *Information Systems Research*; Prof. Guy Gable, the Co-Chief Editor Emeritus of *The Journal of Strategic Information Systems*; Prof. Patrick Chau, a former Chief Editor of *Information and Management*; Galit Shmueli, the Chief Editor of *INFORMS Journal on Data Science*; Prof. Matthieu Guitton, the Chief Editor of *Computers in Human Behavior*; Prof. Chris Westland, the Chief Editor of *Electronic Commerce Research*; and Prof. Robert M. Davison, the Chief Editor of *Information Systems Journal*. Authors of full papers in this conference are welcome to submit their papers to these journals for publication. Because the threat of the COVID-19 pandemic persists and the constraints of the travel time and budget, only three speakers (Kenny, Patrick, and Galit) deliver their speeches on site. All keynote speeches and presentations are delivered with ZOOM software in two virtual meeting rooms, despite many of them are on site with audience. This year’s speeches are scheduled in two mornings and two evenings, considering the time zone differences between the speakers in Australia, Canada, Chicago, China, Hong Kong, New Zealand, and Taiwan. Presentations are also scheduled so authors from other continents can attend the meetings between 8:20 AM and 6:00 PM in Hong Kong Time.



The annual conference of ICEB is an excellent opportunity for the scholars like you and me to share research ideas and get informed about the latest development in the fields. In addition, we could meet leading scholars from around the world to establish a research network and engage in future collaborations. In this conference, there are 89 registered scholars from 19 countries or regions, including Australia, Austria, Belgium, China, Finland, Hong Kong, Hungary, India,



Indonesia, Japan, New Zealand, Saudi Arabia, Singapore, South Korea, Taiwan, Thailand, Russia, United Kingdom, United States and others. This year, the Best Paper Award Committee of 7 members selected one best paper and 7 outstanding papers to receive the awards. The authors of these papers are invited to present their papers in the TWAIS 2023 Pre-ICEB-Conference Workshop. This workshop is a ground-breaking joint effort of the ICEB and the Taiwan Association for Information Systems (TWAIS). The workshop details are available on the conference website.

Finally, on behalf of the entire Conference Committee, we thank you for participating in ICEB 2023 hybrid conference. Without your presence, the conference could not be successful. We also thank all the speakers, presenters, reviewers, program committee members, the Best Paper Award committee members, and session chairs who have contributed their time and effort to this conference. Furthermore, special thanks go to Prof. Benjamin Yen and his conference team from the University of Hong Kong, who provided the administrative and technical support to execute the ZOOM conference events tirelessly and flawlessly. Also, we thank Ms. Yunu Chen of Plum Season Co. for helping our home office set up and manage the payment gateway effectively. Finally, we thank you all for preparing and sharing your research findings in the sessions and look forward to seeing you again in ICEB 2024 in Zhuhai, Guangdong, China hosted by the Beijing Normal University-Hong Kong Baptist University United International College (UIC).

Sincerely yours,

*Eldon Y. Li*

Eldon Y. Li  
ICEB Honorary President  
Chair Professor of MIS  
National Chung Cheng University, Taiwan

*She-I Chang*

She-I Chang  
ICEB 2023 Conference Co-Chair  
Professor and Dean  
College of Management  
National Chung Cheng University, Taiwan

*Benjamin Yen*

Benjamin Yen  
ICEB 2023 Program Co-Chair  
Associate Professor of Business School  
The University of Hong Kong, S.A.R., China

October 2023 in Chiayi, Taiwan, R.O.C.



# TABLE OF CONTENTS

TITLE	PAGE
Preface ..... <i>Eldon Y. Li, She-I Chang &amp; Benjamin Yen</i>	<i>i</i>
<b>PART 1: Full Research Papers</b>	
1. Adoption of data spaces as multi-sided platforms: Towards a preliminary adoption framework <i>Andreas Hutterer and Barbara Krumay</i>	<i>1</i>
2. AI and firm competitiveness <i>John Hamilton, Singwhat Tee and Stephen Maxwell</i>	<i>17</i>
3. An empirical study of impulse purchase in e-commerce live streaming from the e-commerce marketing mix perspective <i>Fuyume Sai and Guannan Su</i>	<i>25</i>
4. Artificial intelligence (AI), Rio Tinto and firm leading-edge ai competitiveness <i>John Hamilton and Stephen Maxwell</i>	<i>36</i>
5. Be human-like or AI-like: Investigating the impact of the anthropomorphism and decision valence on organizational justice and attractiveness in the AI-recruitment <i>Donghwan Kwon, Jooyoung Kim, Sunyoung Choi, Yechan Kim and Hangjung Zo</i>	<i>45</i>
6. Can CAPM (Capital Asset Pricing Model) accurately value assets? <i>Petr Brusov, Tatiana Filatova, Veniamin Kulik, She-I Chang, George Lin and Li-Min Chang</i>	<i>60</i>
7. Cold chain logistics risk analysis based on AHP-FCE method <i>Kun Tian and Zhongming Nie</i>	<i>71</i>
8. Comprehensive risk management matrix in agile EDA project management for semiconductor industry- A case study <i>Terence Sheng-Yow Chen</i>	<i>79</i>
9. Computed tomography usage data analysis model <i>Peiyi Lin and Han Cheng Chang</i>	<i>88</i>
10. Configuration analysis of factors influencing the sales performance of live streaming e-commerce based on the fsQCA method <i>Jianhong Chen, Liezhen Duan, Yuanyue Feng and Congcong Yang</i>	<i>97</i>
11. COVID 19 and information technology: A systematic review <i>Hadeel Alharbi, John Hamilton and Stephen Maxwell</i>	<i>107</i>
12. Decoding business applications of generative AI: A bibliometric analysis and text mining approach <i>May Wang and Pengqi Wang</i>	<i>119</i>
13. Delivering smart warehousing in Australia	<i>131</i>

14. Design and application of artificial intelligent fire fighting robot and development of data module 139  
*Jianjun Hou, Yu Tang, Li Chen and Wen-Min Chen*
15. Development of an AI-based alert system for targeted temperature management patients using machine learning and millimeter-wave technology 148  
*Chia-Lun Lo and Tsung-Lung Yang*
16. Development of Bayesian network-based regional healthcare analysis model for data-driven approach 156  
*Miyako Kawashima, Haruka Ohba and Shinya Mizuno*
17. Dialogues of creation: Collaborative content generation by the human author and ChatGPT and its impact on the evolving intellectual property landscape 166  
*Ya-Chen Liu, Chen-Ho Kuo and Guo-Hua Wang*
18. Distinguishing game engagement from task engagement in the gamification of e-commerce platforms: An empirical study of shopping festival games 186  
*Nan Wang and Yuxing Peng*
19. Domain-adversarial neural network with joint-distribution adaption for credit risk classification 200  
*Jianshan Pan, Yiqiong Wu, Xiaofang Cai, Yang Lv, Jinrui Peng and Wayne Wei Huang*
20. Employee demographics in human resource space in a religious not-for-profit organization in Australia: Understanding for organizational retention rates 208  
*Suzie Pont, John Hamilton and Stephen Maxwell*
21. Enhancing inbound tourism through the Taiwan outdoor project and AI-enabled chatbot management 216  
*Chen-Ho Kuo*
22. Evaluating the key factors affecting hedonic motivations of online video game players 224  
*Doarka Das and Aijaz Ahmed Shaikh*
23. Exploring bibliometric perspectives on data culture in scholarly discourse 232  
*Sunday Adewale Olaleye and Akwasi Gyamerah Adusei*
24. Exploring factors influencing e-learning acceptance: An integration of Transactional Distance Theory and Technology Acceptance Model 244  
*Kun Tian and Jing Wu*
25. Exploring IT affordances and risk management for internationalization activities of business schools 253  
*Bob Nanthakorn, Peter Ractham, Phatsaporn Suwannakart, Lalita Damrourngkunkamjorn and Noptanit Chotisarn*
26. Exploring the influence of AI on purchase intention of electric vehicle among consumers in China 263  
*Ning Fang and Worawan Ongkrutraksa*
27. Factors affecting intention of use electronic ticket service of state railway of Thailand 271

passengers.

*Woranon Chana and Siriluck Rotchanakitumnuai*

28. Fostering Fintech adoption in growing economies: Opportunities, challenges, and strategies 279  
*Eldon Y. Li and Usama Zafar*
29. From adoption to adaptation: Bridging digital transformation and AI integration in contemporary SMEs 291  
*Hsiang An Hu, Hsiao-Ting Tseng, Jian Mou and Jongki Kim*
30. Game theory application for European photonics companies collaborating with Asian EDA firms to develop EDA tools 303  
*Terence Sheng-Yow Chen*
31. Gen Z consumers' purchase intention towards organic cosmetic brands advertised on social media 312  
*Sarita Nagvanshi, Neha Gupta and Vinod Kumar*
32. Home care and mobile health services provision for rural dwellers: a conceptual framework of poverty alleviation and rural development 323  
*Sunday Adewale Olaleye, Ismaila Temitayo Sanusi, Jari Salo and Esther Olubunmi Olaleye*
33. Impact of artificial intelligence (AI) in enhancing productivity and reducing stress among students 334  
*Eldon Y. Li and Anila Jan*
34. Influence of social media platforms on consumers' attitudes for selecting travel destinations. 343  
*Vandana Ahuja, Pooja Sehgal Tabeck and Prerna Arora*
35. Interactive interface design of aging smart home products based on perception ability evaluation 354  
*Shengzan Yan, Yi-nan Li and Yiru Chen*
36. Intervention mechanism for green disposal behavior in the gamification context 365  
*Jingtao Yin, Tuxia Chen, Yixun Lin and Helen S. Du*
37. Introduction of data spaces – Status and recommendations for action 377  
*Andreas Hutterer*
38. Investigating influencing factors of consumer purchase in airport shopping mall: A mixed methods study 391  
*Qiongwei Ye, Danni Zhang and Yumei Luo*
39. Investigating information systems vulnerabilities using machine learning algorithms 401  
*Shiyun Hao, Weihua Li and Xiong Zhang*
40. Investigating the impact of AIGC features on the users' perception of the persuasiveness of AIGC: A perspective of two-dimensional awe emotions 409  
*Xibo Liu, Bo Yang, Haofei Cheng and Yongqiang Sun*
41. Legislation trends: Latest data regulation observations in the U.S. 419  
*Pei-Chuan Chang*



42.	Leveraging technological innovation and retail business during pandemic times <i>Pooja Tabeck and Vandana Ahuja</i>	428
43.	Meet the technological needs of industrial clusters with privacy concerns: A patent recommendation method based on federated learning <i>Zhaobin Liu, Weiwei Deng, Han Chen and Jian Ma</i>	436
44.	Mitigating effects of the early warning time on individual work technostress <i>Xi Chen and Wei-Hsi Hung</i>	445
45.	Online learning experiences and resilience in higher education students: Evidence from India <i>Rupali, Paritosh Mishra and Balvinder Shukla</i>	457
46.	Precision finance: Capital structure theories approach reality <i>Petr Brusov, Tatiana Filatova, Veniamin Kulik, She-I Chang, George Lin and Li-Min Chang</i>	466
47.	Reinventing the case-method teaching approach using a new technological tool <i>Aijaz Shaikh, Shabnam Shaikh and Heikki Karjaluo</i>	481
48.	Research on conceptual design of intelligent products for aquatic plant management in urban river channels <i>Yajing Hou, Shengzhan Yan and Jie Wang</i>	490
49.	Research on the influence of recommended online testing and evaluation on college students' purchase intention of beauty products <i>Yingzhi Guo, Yongzhong Yang and Kunming Luo</i>	502
50.	Research on the model innovation and governance strategy of Jiangsu green supply chain finance development under the digital background <i>Yao Liu, Fei Xu, Jiaqi An, Shun Zhang and Yaqin Dou</i>	512
51.	Research on the relationship between digital job crafting, algorithm aversion and job performance in the digital transformation <i>Qiong Jia, Shan Wang and Wenxue Chen</i>	526
52.	Retrospective analysis of natural disaster impact on firm growth: A case in manufacturing firms in Bangladesh <i>A.B.M. Munibur Rahman, Mohammad Abir Shahid Chowdhury, Zhan Zhan and Arnab Paul</i>	535
53.	Semantics as persuasive cues in donation-based crowdfunding campaigns: The moderating role of donation category <i>Ting-Yu Hsu, Yin-Chi Tsai, Yu-chen Hung, Wenting Liu, Jing Ren, Ding Ding and Jorng-Tzong Horng</i>	545
54.	Social Media advertising in the recent years: A bibliometric analysis and thematic overview <i>Sarita Nagvanshi, Neha Gupta and Vinod Kumar</i>	553
55.	Stakeholder behaviors of peer-to-peer accommodation: A systematic review (2008-2022) <i>Xiaorong Wang, Yifan Ding and Yinghua Huang</i>	573

56.	Stock market or real estate market: Who is the leader? <i>Yao Chun Tsao and Shun-Jen Hsueh</i>	581
57.	Study of short-term price prediction with K-line and SMA for electrical stocks in Taiwan <i>Po-Wen Chen, Kuen-Liang Sue and Pei-Yin Yang</i>	589
58.	Study on the influencing factors of Chinese consumers' continuous purchase intention on cross-border beauty products <i>Zeng Yitang, Tang Xuanbin and Lu Hongxia</i>	602
59.	The application of digital technology in the protection of architectural cultural heritage <i>Jie Wang, Gabriella Medvegy and Jian Jun Hou</i>	610
60.	The design of agricultural UAV system based on Kano-AHP-QFD <i>Shengzan Yan, Jun Wang and Guodong Liang</i>	619
61.	The effect of host personality on property performance and review volume: Evidence from an accommodation-sharing platform <i>Zhiyun Zhang, Pengyu Li and Yanhong Chen</i>	629
62.	The formation mechanism of customer citizenship behaviors in open innovation community based on SOR model <i>Zhang Hua and Liu Shuangji</i>	637
63.	The study of e-business models in hospitality management: Comparing hotel reservation systems of Booking.com, Expedia and Agoda <i>Cheng-Hao Tsai</i>	646
64.	The technologies of digital supply chain in Industry 4.0 <i>Shih-Jung Juan</i>	659
65.	Towards delivering AI & smarter, self-learning, autonomous, humanoid robots <i>John Hamilton, Stephen Maxwell and Paul Lynch</i>	667
66.	Towards understanding university governance within Australia <i>Stephen Maxwell and John Hamilton</i>	675
67.	Unravelling consumer engagement in influencer marketing: An exploratory UGC analysis <i>Yi-Ching Tseng, Pei-Yi Chen, Jing Ren, Yu-chen Hung, Wenting Liu, Jorng-Tzong Horng and Li-Ching Wu</i>	686
68.	User persistence in solving self-service technology problems <i>Alireza Nili, Mary Tate and David Johnstone</i>	694
69.	Utilizing a gamified mobile app to promote post-COVID nurses in managing their self-health <i>Li Jung Lu and Shao Huan Hsu</i>	705

## **PART 2: Work-in-Progress Papers**

70.	Bridging the gap between e-learning and e-business education management in English teaching — A case study of Kaysersberg Education Group in Taiwan <i>Hsiu-Chin Wang</i>	713
-----	--	-----

71. Convolution neural network (CNN) based phishing attack detection model for e-business in enterprise information systems 719  
*Brij B. Gupta, Akshat Gaurav and Kwok Tai Chui*
72. Exploring the interplay between online dating, cyberpsychology, and the dynamics of self-representation and deception: A case study on Tinder 726  
*Gérrard Li and Chen-Yuen Kang*
73. Factors Influencing the formation of false health information 731  
*Kevin K.W. Ho and Shaoyu Ye*
74. Revealing stablecoin successes: Lessons from a case study on USDT 738  
*Wen Shuo Hsu and Cheuk Hang Au*
75. Robot umpire vs. human umpire: The spectators' perception of algorithm errors in baseball games 744  
*Sunyoung Choi, Jooyoung Kim, Donghwan Kwon, Gimok Yun and Hangjung Zo*
76. The impact of live streamer type and live streaming scene type on agricultural product purchase intention: A psychological distance perspective 750  
*Ruixuan Zhang, Nan Wang and Yuxing Peng*
77. The prototypical framing effect in product recommendation 757  
*Yimei Yuan and Bin Ling*
78. Unlocking opportunities amidst obstacles: Navigating Digital transformation challenges in China's manufacturing towns for small and medium-sized enterprises 761  
*Nan Jiang and Ruilin Zhu*
79. Unveiling the potential and pitfalls of ChatGPT: A comprehensive analysis and ethical exploration 767  
*Josefina Yia-Chun Hong*
80. Will ChatGPT remodify the education? The future of business education and research 773  
*Zhan Zhan, A.B.M. Munibur Rahm and Ruichen Cui*



Reference to this book should be made as follows: Li, E.Y. *et al.* Eds. (2023). *Proceedings of The International Conference on Electronic Business, Volume 23* (ISSN: 1683-0040). ICEB'23, Chiayi, Taiwan, October 19-23, 2023, 778 pages.

*Disclaimer: The content accuracy of a paper in this document is the full responsibility of its authors; the ICEB editorial office and the proceedings editors take no responsibility.*



## Adoption of Data Spaces as Multi-Sided Platforms: Towards A Preliminary Adoption Framework

Andreas Hutterer <sup>1,\*</sup>  
Barbara Krumay <sup>2</sup>

\*Corresponding author

<sup>1</sup> Researcher, Johannes Kepler University Linz, Linz, Austria, andreas.hutterer@jku.at

<sup>2</sup> Professor, Johannes Kepler University Linz, Linz, Austria, barbara.krumay@jku.at

### ABSTRACT

Organizations recognize the strategic value of data and explore diverse means of harnessing its potential. Opportunities for data sharing and collaboration via platforms have been discussed. Among these platforms, data spaces, as multi-sided platforms, have gained prominence. Yet, the motivations behind their adoption by organizations remain unclear. Existing literature primarily delves into technical aspects, neglecting socio-organizational considerations. Recognizing the influence of socio-organizational factors in information system adoption, our study addresses this gap. Through a structured literature review, we identify 15 adoption approaches and corresponding factors, spanning individual and organizational levels. Thus, allowing us to derive a preliminary data space adoption framework.

*Keywords:* Data spaces, Multi-sided platform, Platform adoption, Adoption factors.

### INTRODUCTION

The so-called digital economy depends to a great extent on data as a strategic resource for enabling the value generation of organizations. One particular concept that has been considered a “game changer” is the use of platforms (Dmitrieva, 2020; Otto et al., 2015), particularly digital platforms. Their main functions are to act as intermediaries and to bring together supply and demand (Bartelheimer et al., 2022; Kenney & Zysman, 2016). Due to these functions and their importance for the digital economy, the number of digital platforms has increased tremendously, leading to the establishment of the term ‘platform economy’ (Bartelheimer et al., 2022; Kenney & Zysman, 2016). In particular, their intermediary function, i.e., connecting participants sharing economic objectives (e.g., buyers and sellers), has led to the term ‘multi-sided platforms’ (MSPs) to describe this phenomenon (Abdelkafi et al., 2019; Hagi, 2007). Due to the characteristics of digital platforms (e.g., scalability, marginal transaction costs, exploitation of network effects) platformization has become a trend, mainly in business-to-consumer (B2C) markets, over the past decade (Akberdina & Barybina, 2021). There is some evidence that the adoption of MSPs depends on the type of ownership, e.g., single organization vs. alliance-driven (De Reuver et al., 2018). However, many platforms have failed in recent years, due in part to non-adoption (Özcan et al., 2022; Spiekermann, 2019; Yoffie et al., 2019). The idea of MSPs nonetheless remains valid, including concepts beyond the exchange of goods; MSPs facilitate data sharing, as is reflected by the concept of data spaces (Otto & Jarke, 2019a). In this regard, data spaces are typically seen as multi-sided platforms driven by alliances, enabling federated data sharing among multiple organizations (Otto & Jarke, 2019a).

Aside from the enormous potential of digital platforms in terms of doing business (e.g., for transactions of goods and services), it has been argued that the data linked to such platforms comprises an extensive “treasure trove” for participants (Otto & Jarke, 2019b). While data platforms aim at managing the collection of data, they can also be understood in terms of technical infrastructure (Strnadl & Schöning, 2023). Data spaces enable a different means of data sharing amongst participants, as well as the integration of both data and data intelligence (Curry, 2020). As an institutionalization of distributed data integration, a federator in data spaces provides intermediary services (Otto, 2022). Despite their potential, data spaces are a novel type of digital platform and have not yet garnered substantial attention (Beverungen et al., 2022a). Data spaces can be implemented in data environments to ensure data sovereignty (Hutterer & Krumay, 2022; Otto et al., 2016). Interestingly, data spaces and their associated platforms are designed to create data ecosystems that streamline data sharing both within and between organizations (Schleimer et al., 2023). Even though the data space concept is promising (Franklin et al., 2005), the knowledge base about data space adoption remains low (Otto, 2022). Consequently, a “conditional relationship exists between the product platform that underlies the data space and the industry platform that is multi-sided towards its participants” (Strnadl & Schöning, 2023, p. 24). Initially, data spaces were proposed in the industrial sector, in 2010 (J. Guo et al., 2021). More recent initiatives focus on a broader establishment and use of data spaces (European Commission, 2018; IDSA, 2019; Minghini et al., 2022).

As the current literature on data spaces mainly adopts a technical perspective and describes functionalities (Hutterer & Krumay, 2022), it lacks an independent theoretical foundation (Hirsch-Kreinsen et al., 2022). The current body of literature has analyzed the requirements of data spaces and data-driven organizations (DDOs) with a primary focus on delineating capabilities (Hupperz & Gieß, 2024). However, what remains absent is a theoretical framework that can comprehensively describe the adoption of data spaces. Additionally, the socio-organizational aspects of adopting and implementing data spaces have rarely been researched. Therefore, the present study’s focus is on exploring reasons for implementing or adopting data spaces, from a management

perspective. Specifically, we seek to identify the driving factors that motivate organizations to participate in data spaces in a globalized data economy.

Interestingly it has been stated that the body of knowledge regarding B2C platform adoption can hardly be applied to B2B platforms, due to the distinctive conditions under which they operate (Pauli et al., 2021a). In contrast to B2C platforms, B2B platforms have a higher level of technical and commercial complexity, with organizations rather than individual users taking on the role of participants (Hein et al., 2019; Pauli et al., 2021b). Notable, there are several platform concepts in the IS literature (Bartelheimer et al., 2022). Due to definitional inconsistencies of platform subtypes, e.g., MSP (Hagiu & Wright, 2015), we assume that platform adoption research in general may inform data space research. There is research on the adoption of platforms in general, as well as digital platforms in particular (Akberdina & Barybina, 2021; Dmitrieva, 2020). As for data spaces as MSPs, however, research remains—to the best of our knowledge—rather scarce (Beverungen et al., 2022b; Otto & Jarke, 2019b), as “especially the (very) early stages of the MSP emerging – are still relatively unexplored” (Otto & Jarke, 2019b). The goal of this study is therefore to identify factors influencing data space adoption. Given that only a few data spaces have presently been implemented, obtaining the requisite empirical data is challenging. We therefore address the following research question: Which factors influencing platform adoption in general can be identified as also affecting the adoption of data spaces as MSPs? However, as previously noted, data spaces are MSPs and thus share characteristics with digital platforms. Therefore, we present a structured literature review to identify approaches (models, theories, frameworks, etc.) for platform adoption and use the results as a basis for drawing conclusions via analogy. Based on those conclusions and the results from the literature review, we offer a preliminary data space adoption framework for the scientific community.

The remainder of this paper is structured as follows. Section two provides background information on platforms, data spaces, and adoption approaches. In section three, we present the structured literature review. Our results, particularly focused on outcomes from the literature review, are presented in section four. Section five discusses these results, focusing mainly on the applicability of the approaches for the adoption of data spaces, including the emergent preliminary data space adoption framework. Finally, we present the study’s conclusions, discuss its limitations, and propose future research priorities.

## BACKGROUND INFORMATION

Platforms, which have become a central component of digital business models in the past ten years, provide an infrastructure for commodity exchange (De Reuver et al., 2018; Dmitrieva, 2020). Electronic marketplaces, for example, are platforms characterized by both buying and selling features (Schmid & Lindemann, 1998), making them an integral part of the entire transaction of goods and services (Yanagisawa & Guellec, 2009). Marketplaces in general (electronic or otherwise) serve three main functions: (1) matching buyers and sellers, (2) facilitating transactions, and (3) providing the institutional infrastructure for business markets (Bakos, 1998). Although transaction platforms represent marketplaces, not all platforms connecting buyers and sellers manage whole transactions (Koutroumpis et al., 2017). Platforms also allow technological and engineering perspectives, qualifying platforms as a type of technological architecture classified by their participants, e.g., internal platforms, supply-chain platforms, or industry platforms (Gawer, 2014). Digital platforms, naturally generate data as a byproduct of their operations, primarily provide a diverse range of services that extend beyond data-related functions (De Reuver et al., 2022). In contrast, data platforms specialize in facilitating data exchange and monetization, playing a crucial role in driving the emerging data economy and manifesting in diverse forms, i.e., data marketplaces (Abbas et al., 2021), data collaboratives (Susha et al., 2017) and data spaces (Beverungen et al., 2022b). Further, the literature does not offer a comprehensive exposition elucidating the motivations and incentives underpinning data sharing (Gelhaar et al., 2023). In the realm of academic discourse, there remains an ongoing lack of precise definition regarding the concept of data sharing, particularly in the context of its interchangeable usage within the literature, e.g., data exchange (Jussen et al., 2023). In addition, there is a notable lack of research that addresses the barriers organizations face in the practice of data sharing (Fassnacht et al., 2023).

The digital economy has yielded not only digital marketplaces but also platforms to enable extensive data exchange (De Reuver et al., 2022; Stahl et al., 2014). Although data can also be made available free of charge, as in the case of open data (Zuiderwijk et al., 2014), data marketplaces, also referred to as data platforms, have been specifically designed to facilitate data exchange (Abbas et al., 2021, 2023; Fruhwirth et al., 2020). In their digital form, their potential is fully exploited, allowing fast and easy exchange of data and thus contributing to the value generation of organizations (Abbas et al., 2022; Spiekermann, 2019). The architecture of such marketplaces may be either centralized or decentralized (Koutroumpis et al., 2017). While centralized architectures are mainly driven by a cloud service or data storage provider, decentralized architectures allow the preservation of data sovereignty, as the data remains with the organization providing the data (Spiekermann, 2019). However, this makes “the exercise of data processing and data storage more difficult for the actors” (Spiekermann, 2019). In this regard, the data space concept exhibits the same characteristics: It is defined as an MSP for sharing data, allowing data management via a Data Space Support Platform (DSSP), while following a decentralized approach (Franklin et al., 2005; Otto & Jarke, 2019b). Data Spaces allows data sharing amongst participants while also preserving data access at the same time (Franklin et al., 2005). When data sharing between different organizations in data spaces is established, data ecosystems evolve (Gelhaar & Otto, 2020). Beyond the technical perspective, a data space also represents a sociotechnical system (M. Singh & Jain, 2011), with specific requirements related to the socio-organizational perspective, such as security (Brost et al., 2018).

The data space concept (Franklin et al., 2005) and in particular DSSPs serve as the basis for data spaces designed as a multi-sided data platform (Otto & Jarke, 2019b). While the term ‘data space’ appears to have broad usage in both academic and

business contexts, there is significant variation in the understanding of its defining characteristics (Hutterer et al., 2023). Its design aims to establish a platform ecosystem while ensuring data sovereignty by developing an architecture (Otto & Jarke, 2019b), as proposed by the IDS initiative (IDSA, 2022c). The DSSPs, i.e. federators, as conceptions of a data intermediary, provide data intermediation services between participants (Schweihoff et al., 2023), enabling direct exchange between participants (Otto, 2022). Moreover, data spaces consist of six elements: (1) a connector (ensures that participants maintain sovereignty over the data); (2) a metadata broker (i.e., a data source registry); (3) a vocabulary provider (service to create, maintain, manage, monitor, and validate identity information of and for participants); (4) an identity provider (a one-stop-shop to safeguard and secure data exchange); (5) an app store (for provision of apps); (6) a clearing house (provides clearing and settlement services for all financial and data exchange transactions) (Drees et al., 2021; Pettenpohl et al., 2022). Interestingly, a data space can have different architectures (Schleimer et al., 2023) or designs (Gieß et al., 2023). Specifically, there are several design options for data space connectors (Gieß et al., 2024). Varying centralized approaches with operating companies as federators (Catena-X, 2023; Mobility Data Space, 2023), or more decentralized approaches like Pontus-X (Pontus-X, 2023). For example, the Pontus-X network (GEN-X) blockchain-network (Pontus-X, 2023) is a distributed ledger technology based on Ocean Protocol (Ocean Protocol Foundation, 2022). Various data space projects have been initiated (Steinbuss et al., 2023), unfortunately mostly focus on Europa at the beginning. Due to global value chains, such as Catena-X in the automotive sector (Catena-X, 2022), there is a pursuit of internalization (Catena-X, 2023; IDSA, 2022b). Thus, the IDSA becomes a global initiative (Bub, 2023; Jürjens et al., 2022), which additionally certifies components (Pettenpohl et al., 2022), i.e., connectors (Giussani & Steinbuss, 2023).

Although the concept of platforms is generally promising, some platforms have failed (Özcan et al., 2022). Such failures can be due to a lack of adoption or falling short of the critical mass of participants needed to benefit from network effects (Spiekermann, 2019; Yoffie et al., 2019). Information systems research has explored the adoption of technologies broadly, as is reflected by the various concepts, theories, and frameworks that have been proposed to address the issue of factors influencing technology adoption (Alhammadi et al., 2015; Al-Suqri & Al-Aufi, 2015). Technology adoption in general has been defined as “the first use or acceptance of a new technology or new product” (Khasawneh, 2008). Technology adoption can be analyzed at an individual or organizational level or both (Jeyaraj et al., 2006; Stieglitz et al., 2018), both of which have been addressed by the Innovation Diffusion Theory (IDT), also referred to as diffusion of innovation (DOI) (Al-Suqri & Al-Aufi, 2015; Rogers, 1995). However, many other approaches focus on the individual level, i.e., determining the factors that influence an individual’s decision to adopt or not adopt certain technologies (Deng et al., 2019). Within the information systems literature, the Technology Acceptance Model (TAM) (Davis et al., 1989; Venkatesh & Davis, 2000) seems to be the most widely used (S. Hong et al., 2006; Rahimi et al., 2018; Scholten, 2017). TAM has progressed through different iterations and has been applied to a range of topics, including online investments (Konana & Balasubramanian, 2005), telemedicine services (Kamal et al., 2020), and autonomous driving (Koul & Eydgahi, 2018). Other approaches to explaining adoption include the Perceived Characteristics of Innovations (Moore & Benbasat, 1991), Social Cognitive Theory (Bandura, 1986), the Theory of Planned Behavior (TPB) (Ajzen, 1991), and the Theory of Reasoned Action (Fishbein & Ajzen, 1975). The Unified Theory of Acceptance and Use of Technology (UTAUT) is another example that combines eight different approaches in a condensed model (Venkatesh et al., 2003). In contrast, at an organizational level, the technology–organization–environment (TOE) framework is widely applied, mainly regarding technology adoption decisions (Tornatzky et al., 1990). The framework is a versatile approach for evaluating technology adoption and can be extended to include other approaches (Oliveira & Martins, 2011). It has been applied to topics including cloud computing (Low et al., 2011; Oliveira et al., 2014), the Internet of Things (IoT) (Lin et al., 2016; Sivathanu, 2019), or Enterprise Systems (Boumediene & Kawalek, 2008). Other models of organizational-level technology adoption include the diffusion/implementation model (Kwon & Zmud, 1987) and the Tri-Core Model (Swanson, 1994). Some research to date has compared different approaches on different levels. For example, comparing adoption on the individual level based on TAM versus adoption on the organizational level based on the TOE framework showed that both frameworks are valid but can be integrated based on specific variables (Gangwar et al., 2015).

## METHODOLOGY

This study aims to identify factors influencing data space adoption. Our research uses existing approaches (models, theories, frameworks, etc.) for platform adoption in general to draw analogy conclusions for data space adoption. We apply a three-stage process approach for the structured literature review (SLR), as developed by Tranfield et al. (2003), to create a reliable knowledge stock. The approach has been applied in various IS research studies, e.g., in the context of digital twin (Jones et al., 2020), industry 4.0 (Ghobakhloo, 2020) or digital transformation (Hanelt et al., 2021). In the first stage, the procedure is planned based on the research question. In the second stage, the literature is selected and analyzed. In the final stage, the results are presented.

We drew inspiration for the screening from the process proposed by Dybå and Dingsøyr (2008). For a high-quality selection of scientific literature, the following databases were consulted: ACM Digital Library, IEEE Explore, ScienceDirect, and Scopus. Based on our study’s research question, keywords were identified (i.e., ‘platform’, ‘adoption’). Given that data platforms and data spaces exhibit distinctions from digital platforms, and their characteristics are not readily transferable (De Reuver et al., 2022), we have opted to employ the broad term “platform” as a keyword. As the combination of these keywords (‘platform’ AND ‘adoption’) yielded more than 15,000 results, the search criteria were further refined. First, only articles published in English from 2010 to 2021 were considered, in order to prioritize more recent results. The timeframe was set this way because data spaces first appeared in the industrial domain in 2010 (J. Guo et al., 2021). Literature was excluded due to a lack of content fit (e.g., title not focusing on platforms); we also excluded technical articles, newsletters, and gray literature. Because there has

already been an exploration of the technical problem-solving aspects of data spaces (Hutterer & Krumay, 2022), we have conducted a focused search for non-technical dimensions. After the additional exclusion of unavailable papers, 107 remained. Next, redundant and inaccessible studies were excluded, leaving a total of 83 publications. By reading their abstracts, further studies were excluded due to not fitting the research aim (n=27). Following the final quality assessment, a total of 21 papers were used for the analysis. Because our research question centers on identifying factors related to the adoption of data spaces, this step involved excluding articles that do not address technology adoption approaches, as they do not align with the scope of this study, i.e., Hallikainen & Aunimo (2020).

## RESULTS

The studies selected for further analysis showed that there is growing interest in the adoption of digital platforms. In our sample of papers published between 2010 and 2021, only one paper (X. Guo et al., 2010) was published 2010, with a growing number of studies published over time, including five publications in 2020 (De Prieelle et al., 2020; Delgosha & Hajiheydari, 2020; Tamilmani et al., 2020; Tomičić-Pupek et al., 2020; Zeng et al., 2020). Eight papers in the sample were published in conference proceedings, whereas 13 are journal papers, some of which were in highly ranked journals.

### Classification Results

To identify approaches related to platform adoption, we performed an analysis of the papers in our sample. Based on this analysis, we identified 15 different approaches, of which only five focused on the organizational level (see Table 1). Only one study (X. Guo et al., 2010) investigated adoption on both levels, six studies focused exclusively on the organizational level, and the rest (14) were at the individual level. Interestingly, some studies based their investigation on more than one approach or even combined approaches (Arif & Suzianti, 2019; Blesik & Bick, 2016; Freire et al., 2014; X. Guo et al., 2010; Hasyati & Suzianti, 2018; S. Hong et al., 2006; Song et al., 2018). At the individual level, we found UTAUT to be the most widely used approach (seven times), followed by TAM (five times), and IDT/DOI (three times). All other individual-level approaches were each used in only one study. At the organizational level, most studies applied the TOE framework (five studies), followed by the IDT/DOI approach (two studies). In addition, two studies provided comprehensive overviews of adoption factors (De Prieelle et al., 2020; J. Hong et al., 2021). Table 1 shows a detailed analysis of the 21 selected articles, identifying a total of 154 adoption factors.

Table 1: Adoption approaches for platforms on individual and organizational levels

Adoption Level	Study	Factors from approaches	Research framework	Platform
Individual & Organizational	(X. Guo et al., 2010)	Consumer: Intention, Attitude, Subjective Norm, Controllability, Self-Efficacy, Merchant Abundance, Product Abundance, Usefulness, Ease of use, Facilitating Conditions, External Influence, Information Protection Merchant: Usage Decision, Relative Advantage, Compatibility, Costs, Security Concern, Organization Size, Competitive	Consumer: TPB  Merchant: TOE framework and IDT	Mobile Marketing Platform
Individual	(Xie et al., 2021)	Social Influence, Facilitating Conditions, Performance Expectancy, Effort Expectancy, Perceived Risk	UTAUT	FinTech Platform
	(A. Singh et al., 2021)	Perceived Usefulness, Perceived Ease of Use, Cost Effectiveness, Interactivity	TAM	Digital Collaboration Platform
	(Tamilmani et al., 2020)	Social Influence, Performance Expectancy, Effort, Expectancy, Hedonic Motivation, Facilitating Conditions, Self-Efficacy, Trust	Revised UTAUT	Airbnb Platform
	(Delgosha & Hajiheydari, 2020)	Perceived complexity, Platform application security concerns, Service provider performance ambiguity, Service provider trust worthiness issues, Financial concerns, Financial benefits, Flexibility, ODSP application superior functionality, ODSP special services	Behavioral Reasoning Theory (BRT)	On-demand Service Platform

	(Tomičić-Pupek et al., 2020)	Relationship history, Payment options, Comfort & convenience, Customer recommendations (C2C2C), Community support, Producer's reliability, Trust & traceability, Regulatory compliance, Incentives and sustainability, Outbound logistics, Innovations, Inbound logistics, Resources, Product Quality, Producing technologies, Health & food safety, Sales channels, Eco-friendliness, Location & time (from farm to fork)	Value Adoption Model (VAM)	Digital Platform in Agriculture
	(Arif & Suzianti, 2019)	Cognitive Need, Affective Need, Social Need, Performance Expectancy, Effort Expectancy, Social Influence, Facilitating Conditions	Uses and Gratification Theory (UGT)	Mobil learning platform
	(Syafinal & Suzianti, 2019)	Confirmation, Perceived Usefulness, Perceived Ease of Use, Perceived Risk, Satisfaction, Attitude, Subjective Norms, Continuance Intention	Technology Continuance Theory (TCT)	Booking service platform
	(Kurniawan, 2019)	Ease of use, Usefulness, Perceived Benefit, Perceived Risk, Credibility, Trust, Attitude, Behavior Intention to Use, Actual Use	TAM	Lending service platform
	(Hasyati & Suzianti, 2018)	Performance Expectancy, Effort Expectancy, Facilitating Conditions, Social Influence, Information Quality, System Quality, Trust, Compatibility	Information Systems Success Model (ISSM)	Online Platform for Development Planning Discussion
	(Song et al., 2018)	Relative advantage, Platform innovativeness, Technical compatibility, Platform openness, Market potential, Marketability, Developer tools, Personal benefit, Enjoyment, Related knowledge, Personal innovativeness, Social influence	SCT = Social Cognitive Theory	IT-Platform for mobile application developers
	(Blesik & Bick, 2016)	Internal Motivation, External Motivation, Internal Self Concept, External Self Concept, Importance of Crowdsourcing Features, Importance of Restrictive Features, Perceived Ease of Use, Perceived Unintentional Risk	TAM and UTAUT	Medical Information Platforms
	(Steiner et al., 2016)	Perceived Hardware Price, Perceived Software Price, Perceived Monetary Sacrifice, Perceived Software Quality, Perceived System Value, Perceived Software Variety, Expected Installed Base, Expected Direct Network Effect, Expected Indirect Network Effect	Perceived Value Model (PVM)	Platform-based systems for entertainment products
	(Freire et al., 2014)	Social influence, trust, perceived privacy, perceived security, age, gender, internet experience, perceived web design, perceived ease of use, relative advantage	TAM, DOI, and UTAUT	E-government platforms
	(Miranda et al., 2014)	Testability, Observability, Compatibility, Complexity, Relative Advantage	Diffusion of innovations	Mobile development platforms
Organizational	(Chaudhary & Suri, 2021)	Price, Transaction Cycle, Easy to User, Infrastructure, Customer Career, Social Influence, Trust, Cost	Multilayer Perceptron (MLP)	Agricultural e-trading platform
	(J. Hong et al., 2021)	Organizational resources, External pressures, Ease of use, Relative advantage, SCSP adoption, Quality performance, Economic performance, Platform governance	Inter-organizational Relationship Theory (IOR)	Supply chain service platforms
	(Zeng et al., 2020)	Ease of use, Usefulness, Relative advantage, Cost, Information confidentiality, Service quality, Top management support, Firm size, Ownership structure, Industrial characteristics Power: authority, supply chain partners, Institutional environment	TOE Framework	Inter-organizational information systems (IST)



	(De Prieelle et al., 2020)	Benefits, Costs, Ease-of-use, Compatibility, Reliability, Scalability, Security, Technological readiness, Financial readiness, Human readiness, Application user readiness, Enabling party readiness, Trust in application user, Trust in enabling party, Relative power application user, Relative power enabling party, External pressure, Regulation, Governance mode, Governance of data ownership, access, Governance of data usage	TOE Framework	Data platform
	(Shim et al., 2018)	Network Effect Benefits, New Platform Benefits, New Platform Risk, Organizational Learning, Mimetic Pressure, Competitive Pressure, Firm Size, Firm Year, Profit	TOE Framework	Open platform
	(Gebregiorgis & Altmann, 2015)	Attractiveness of IT Platform, Number of Actual Customers, Revenue, Allocated Budget for Improving QoS, Usability, Portability & Interoperability, Standards, Market Power, Platform Maturity, Trust, Switching & Integration Cost, Training Cost, Charge per Customer, Quality of Service, Total Cost, Customer Satisfaction, Attractiveness of IT Platform.	Value Creation Model (VCM) and System Dynamics Methodology	IT-Service platforms

### **Individual and organizational level**

As already mentioned, only one paper in the sample investigated adoption at both the individual and the organizational level (X. Guo et al., 2010). For that study, an integrated two-sided framework was developed to analyze platform adoption by consumers and merchants. The consumer side was based on TPB, whereas the merchant side combined IDT and TOE approaches, which were extended to include factors that incorporate cross-network effects. Based on a quantitative approach, Guo et al. (2010) concluded that a platform's cross-network effects do not directly affect user attitudes toward the platform. In addition, the effect of information protection was also found to be insignificant. However, network effects were found to be of particular importance. On the merchant side, competitive pressures harm adoption decisions; thus, network effect factors have significant effects. The size and value of the consumer group were found to have significant impacts on relative advantage. Overall, the two-sided cross-effects were found to promote the adoption of platforms by smaller firms.

### **Individual level**

Our sample included 14 studies that focused on the individual level. These papers investigated a range of different platforms, including FinTech platforms (Xie et al., 2021), digital collaboration platforms (A. Singh et al., 2021), and Airbnb (Tamilmani et al., 2020). The majority of the papers used UTAUT; however, this was mostly in combination with other approaches and applied quantitative analysis. Xie et al. (2021) even extended UTAUT in the context of FinTech platforms, by using financial consumption attributes to complement UTAUT. They concluded that adoption intention in this context is strongly influenced by perceived value, perceived risk, and social influence. Furthermore, perceived value is influenced by the effects of performance expectancy, effort expectancy, and perceived risk. As an example, Freire et al. (2014) investigated the adoption of e-government platforms by Portuguese citizens. To develop a conceptual model, they used TAM, DOI, and UTAUT as a basis. To measure usage intentions, they employed a combination of factors, including trust, privacy, social influence, security, relative advantage, web design, and perceived ease of use. Similarly, Arif and Suzianti (2019) investigated the adoption of mobile devices for a learning platform, by combining UTAUT and UGT approaches. Their quantitative analysis showed that four factors significantly influence mobile application usage: (1) cognitive need, (2) effort expectancy, (3) intention to use, and (4) facilitating conditions. Furthermore, Blesik and Brick (2016) studied crowdsourcing platforms for medical diagnostics, by combining TAM and UTAUT approaches. Integrating user acceptance, risk avoidance, and motivational influencing factors revealed a correlation between risks and functions; in addition, these factors also influenced perceived usefulness (PU), i.e., PU is decreased by perceived risks and increased by crowdsourcing functions. Furthermore, external motivation was identified as an influencing factor.

In contrast, Hasyati and Suzianti (2018) aimed to develop an adoption strategy based on UTAUT and ISSM. They investigated the Online Platform for Development Planning Discussion and identified six acceptance factors, of which social influence, facilitating conditions, and performance expectancy were found to significantly influence adoption intentions. Song et al. (2018) based their research on TAM, UTAUT, DOI, and social cognitive theory; they used these approaches to analyze platform adoption of developers, consumers, and manufacturers. In the first step of their study, factors from perceived platform characteristics, perceived network externalities, individual characteristics, and social interaction were identified. Unlike previous adoption studies, this study also incorporated technology characteristics and network externalities. The analysis determined that IT platform adoption is influenced by developers' perceived platform characteristics, individual characteristics, network externalities, and social influence. Furthermore, Tamilmani et al. (2020) investigated individuals' usage intentions of Airbnb based on a revised UTAUT model, which included hedonic motivation, trust, and self-efficacy factors. They found that effort

expectancy, social influence, and facilitating conditions have a major influence on technology usage intentions; performance expectancy, attitude, trust, and self-efficacy also exert a direct influence.

In addition to UTAUT, TAM was identified as an investigation basis five times in our study's sample, with TAM and UTAUT combined in three of these studies (Blesik & Bick, 2016; Freire et al., 2014; Song et al., 2018). The two remaining studies using TAM to investigate digital collaboration platforms (A. Singh et al., 2021) and a peer-to-peer lending platform (Kurniawan, 2019). Kurniawan (2019) based their research on TAM, showing that perceived benefit, trust, usefulness, and ease of use all represent significant influencing factors. In contrast, A. Singh et al. (2021) examined adoption intentions on digital collaboration platforms based on TAM, finding that interactivity, cost-effectiveness, perceived usefulness, and perceived ease of use all positively influence adoption. DOI was found to be the underlying theory used in three studies, while two other studies (Freire et al., 2014; Song et al., 2018) combined it with UTAUT and TAM. Only Miranda et al. (2014) relied solely on DOI, to investigate software developers' mobile platform choices. Interestingly, this study applied a qualitative method (i.e., semi-structured interviews) and grounded theory techniques (Charmaz & Belgrave, 2012). The results showed that developers value different characteristics of mobile platforms, with the Android platform being valued for accessibility and compatibility and iOS being valued for the seemingly more lucrative platforming.

Other approaches in explaining adoption were each found in only one paper and often in combination with other approaches. In particular, these include ISSM in combination with UTAUT (Hasyati & Suzianti, 2018), SCT in combination with TAM, UTAUT and DOI (Song et al., 2018), TPB in combination with TOE (X. Guo et al., 2010), and UGT in combination with UTAUT (Arif & Suzianti, 2019). Hence, four remaining approaches have not been discussed. Delgosha and Hajiheydari (2020) applied BRT to investigate the acceptance of and resistance toward on-demand service platforms to assess digital platforms as new sociotechnical systems. Their study revealed that the negative effects of reasons against can lead to bias in terms of reasons for, which could influence consumers' attitudes and adoption intentions. Consequently, their study provides insights into the logical processes for and against the use of digital platforms. In contrast, Syafinal and Suzianti (2019) investigated the factors influencing the use of platform X, a health application used to manage sports activities. Their analysis employed TCT to investigate the influence of confirmation, perceived usefulness, perceived ease of use, perceived risk, satisfaction, attitude, and subjective norms on usage continuance intentions. Tomičić-Pupek et al. (2020) examined adoption factors in the agricultural industry based on the VAM, including perceptual factors, which were used to investigate individuals' intentions to join. Overall, their study provides an improved understanding of matching between consumers and producers. Finally, Steiner et al. (2016) investigated the expectation of direct and indirect network effects on the game console market based on the PVM. The "give" components (i.e., software variety and quality) and "get" components (i.e., hardware prices, software prices, and monetary sacrifice) define the value of the system. Their study showed that new platforms can benefit from improved targeting, especially, at the beginning of the customer lifecycle; as the platform progresses, the offering can be expanded. Furthermore, the authors highlighted the need to integrate behavioral insights into go-to-market strategies.

### **Organizational level**

At the organizational level, the platforms investigated by previous studies range from the agricultural (Chaudhary & Suri, 2021) to the maritime sector (Zeng et al., 2020). The most widely used framework is TOE (five studies); however, the TOE-based study combining organizational and individual levels (X. Guo et al., 2010) has been discussed above. Hong et al. (2021) examined the academic literature for theories applicable to supply chain service platforms that coordinate the flows of goods. The authors used TOE, IDT, and IOR as the theoretical underpinnings for their research. Their analysis revealed that organizational resources and external pressures have significant and direct influences on platform adoption. Furthermore, both factors impact the perceived value of the platform, thus illustrating that platform adoption and company performance are positively correlated. The study by De Prieelle et al. (2020) describes the facilitated exchange of IoT data via platforms. The authors identified adoption factors for inter-organizational systems in the existing literature, to supplement the TOE framework. The study's data, collected from the vegetable growing industry, were analyzed using multi-criteria decision analysis, based on the best-worst method. Interestingly, they found that benefits and readiness were considered the most important aspects, while ecosystem data governance was ranked as the most significant factor for platform providers. Using an adapted TOE framework, Zeng et al. (2020) examined the adoption of a platform for cross-organizational information sharing in the maritime sector. The authors identified factors in their model, such as industry characteristics, the confidentiality of the system's information, the power of trading partners in the supply chain, governmental power, and the ownership structure of the company. Based on their analysis, system confidentiality, service quality improvement, ownership structures, and government legislation were found to be of significant influence. Furthermore, their work identified that initiatives by market-constraining actors can drive adoption readiness. The final study applying TOE investigated the adoption of open platforms in organizations (Shim et al., 2018). For this purpose, the authors designed a TOE framework that drives herding. This model includes network effect benefits, new platform benefits, new platform risks, organizational learning, mimetic pressures, and competitive pressures. Their study reveals two distinct phases. In the first phase, new platform risk and organizational learning influence herd behavior; in the second phase, the benefits of new platforms and competitive pressures determine herd behavior. These phases can be explained by the fact that when platforms are successfully adopted, competitors then imitate the early adopters.

The studies using IDT (X. Guo et al., 2010; J. Hong et al., 2021) and IOR (J. Hong et al., 2021) have already been presented; thus, MLP (Chaudhary & Suri, 2021) and VCM approaches remain (Gebregiorgis & Altmann, 2015). Chaudhary and Suri (2021) explored the adoption factors of wholesale e-trading platforms, based on MLP. Due to the lack of literature in this area, the

authors identified adoption factors in the first phase of their study and subsequently established a research framework. Predictions regarding the adoption of the agricultural trading platform were generated using a neural network-based classification tool, which incorporated the MLP procedure. On this basis, it was found that the two most crucial factors influencing the adoption of an agricultural trading platform are fast transaction cycles and higher prices. Gebregiorgis and Altmann (2015) investigated the influence of openness on cloud computing platform adoption. In contrast to closed platforms, open IT service platform systems are defined by their portability, interoperability, and usability. Accordingly, the authors designed a value creation model for IT service platforms. The simulation results reveal only an understanding of trends in the market.

## DISCUSSION

Due to the expectations expressed towards data spaces in research, business, and policy making, their adoption is an important topic for the near future. Because the extant research literature lacks an approach to describe or explain data space adoption, this study aimed at identifying factors influencing data space adoption. As literature on actual data space adoption is scarce (Hutterer & Krumay, 2022), we investigated literature on platform adoption in general. We identified 15 approaches (models, theories, frameworks, etc.) as the basis for deriving a preliminary framework for data space adoption, mainly to lay the foundations for further academic discussion. Accordingly, our study contributes to the academic knowledge on this topic area, and also provides insights for prospective data space participants. Although the 21 papers examined in our study mainly focused on platform adoption, they nonetheless yield important insights for data space adoption.

The papers identified in the SLR addressing data platforms (De Prieelle et al., 2020), open platforms (Shim et al., 2018), and supply chain service platforms (J. Hong et al., 2021) even discussed challenges to data sharing via a platform. In this regard, data governance (in particular, ecosystem data governance) emerged as a relevant influencing factor for adoption (De Prieelle et al., 2020). Data governance involves governance modes, ownership and access, and data usage, all of which influence platform adoption (De Prieelle et al., 2020). Governance of data ownership and control is particularly essential for organizations that participate in platforms, and the mode of governance is a critical success factor for platforms (Provan & Kenis, 2007; Van Den Broek & Van Veenstra, 2015). In addition, the mimetic pressure in the terms of perceived rate of competitors' adoption seems essential to platform adoption (Shim et al., 2018), as does the perceived value of the platform for its participants (J. Hong et al., 2021). The results of the literature review reveal that external pressure is an environmental factor that has the potential to impact the decision-making processes regarding use of a data space (De Prieelle et al., 2020; J. Hong et al., 2021; Iacovou et al., 1995; Lippert & Govindarajulu, 2006; Rui, 2007; Shim et al., 2018; Sun et al., 2018). Furthermore, trust (Gelhaar & Otto, 2020), particularly regarding the reliability of a platform, positively affects user appeal in platforms (Chaudhary & Suri, 2021; De Prieelle et al., 2020; Gebregiorgis & Altmann, 2015). Within the literature, regulation has been recognized as an environmental factor that pertains to the guidelines and legal provisions governing the sharing of data (De Prieelle et al., 2020; Lippert & Govindarajulu, 2006).

The decision to adopt data spaces may also be affected by a range of organizational factors that can either support or hinder the process. One particularly critical factor is the support of top management, which has been shown to be important for technology adoption in general and may also apply to data spaces (Ilin et al., 2017; Kurnia et al., 2015; Oliveira et al., 2014; Reyes et al., 2016; Zeng et al., 2020). Another set of key factors relates to the readiness of an organization, which consists in having the appropriate technological resources (De Prieelle et al., 2020; Grover, 1993; Iacovou et al., 1995; Kuan & Chau, 2001; Premkumar & Ramamurthy, 1995; Rui, 2007; Zhu, Xu, et al., 2003) as well as sufficient financial resources to cover the costs of implementation (Bouchbout & Alimazighi, 2008; De Prieelle et al., 2020; Grover, 1993; Iacovou et al., 1995; Kuan & Chau, 2001; Premkumar & Ramamurthy, 1995; Zhu, Xu, et al., 2003). In addition, human resources—more specifically, employees with the necessary knowledge and skills—are also important (Chau & Tam, 1997; De Prieelle et al., 2020; Grover, 1993; Iacovou et al., 1995; Rui, 2007; Zhu, Xu, et al., 2003). Finally, the size of an organization may also be a significant factor in technology adoption, including the adoption of data spaces (Harris et al., 2015; Kurnia et al., 2015; Lai et al., 2006; Oliveira et al., 2014; Shim et al., 2018; Wang et al., 2010; Zeng et al., 2020).

Interestingly, several factors were identified that may influence the technological implementation of data spaces. Relative advantage is the perceived improvement of the technology over existing alternatives (De Prieelle et al., 2020; J. Hong et al., 2021; Shim et al., 2018; Zeng et al., 2020). Furthermore, compatibility concerns how well a technology aligns with an organization's existing values, experiences, and needs (Bouchbout & Alimazighi, 2008; De Prieelle et al., 2020; Rogers, 1995; Rui, 2007). Costs are the expenses incurred by an organization when adopting the platform (Chaudhary & Suri, 2021; De Prieelle et al., 2020; Gebregiorgis & Altmann, 2015; Zeng et al., 2020; Zhu, Kraemer, et al., 2003). Scalability consists in the ease with which the platform can be adjusted, in terms of size, scope, and function (Bouchbout & Alimazighi, 2008; De Prieelle et al., 2020; Lippert & Govindarajulu, 2006). Security is a major concern in organizations when activities are performed over the internet; this relates to security attributes of the platform (Bouchbout & Alimazighi, 2008; De Prieelle et al., 2020; Fu et al., 2014; Lippert & Govindarajulu, 2006; Yang & Maxwell, 2011).

Further aspects that may play a role can be derived from the existing literature. Other influencing aspects relate to the ecosystem typology (Guggenberger et al., 2020), such as openness, centralization vs. decentralization, and data sovereignty; these are all influencing factors for platform adoption (Spiekermann, 2019; Zuiderwijk et al., 2014). However, beyond the architecture design options of the data space (Schleimer et al., 2023), there also seems to be a need for an architecture description (Bianco et al., 2014). While data spaces serve as technical platforms, they also represent sociotechnical artifacts and market intermediaries

(Otto & Jarke, 2019b). As data spaces extend from internal platforms to industry platforms, they may contribute to the development of a data ecosystem (Gelhaar & Otto, 2020). Accordingly, data ecosystems with neutral intermediary aspects should promote cross-organizational data exchange (Gelhaar & Otto, 2020). We therefore conclude that the key component for data space adoption is a data space platform that both fulfills organizations' needs and fits their interests (e.g., perceived benefits). Furthermore, a platform might also encompass the external task environment (Scholten, 2017; Tornatzky et al., 1990). Although some digital platforms have failed (Özcan et al., 2022; Yoffie et al., 2019); there are nonetheless many trends for overcoming such hurdles (Spiekermann, 2019).

Additionally, it is important to relate these factors to a theoretical underpinning. From the sample papers, we surmised that studies focusing on the individual level of platform adoption mainly used UTAUT and TAM as underlying theoretical models. By contrast, the TOE framework was dominant in the studies focusing on the organizational level. Although the platforms' contexts differed greatly, including FinTech (Xie et al., 2021), Airbnb (Tamilmani et al., 2020), or mobile learning platforms (Arif & Suzianti, 2019), especially on an organizational level, the results of the study were promising. Clearly, it is possible for an individual user to participate in a data space. However, we assume that data space adoption will generally be undertaken at an organizational level. As our study focuses on enterprises, i.e., industrial data spaces (Otto et al., 2016), the results allowed us to offer insights regarding data space adoption. Thus, we adhere to the definition of data spaces as multi-sided data platforms (Otto & Jarke, 2019b), mainly involving organizations as participants. Following the results from our sample, we used the TOE framework (Tornatzky et al., 1990) as a basis for the preliminary data space adoption model. The TOE framework depicts the technology, organization, and external task environment related to technological innovation decision-making (Tornatzky et al., 1990). Based on the insights gained from our SLR, we conclude that the TOE framework approach constitutes an opportunity to describe the adoption of data spaces. Notably, the factors of the framework are dependent on the technology it focuses on. Thus, while the TOE is generally a good solution, this framework can be extended with other approaches or individual factors specific to data spaces. In our example, the TOE framework is extended with an factor from the Interorganisational Relationship Theory (IRT) (J. Hong et al., 2021).

The factors identified may also serve as bases for decisions made by organizations aiming to participate in a data space, as well as decisions made by data space providers. The main goals of a data space seem to be to generate value and increase organizations' competitiveness (Beverungen et al., 2022b). Hence, data platform providers should aim to realize added value and innovations for organizations (Bartelheimer et al., 2022). Because applications of data spaces are scarce (Czvetkó & Abonyi, 2023; Steinbuss et al., 2023), prospective participants are forced to rely on the few existing implementations. For example on supranational level, the EU Data Strategy (European Commission, 2023; Minghini et al., 2022) aims to create nine interoperable domain-specific data spaces that should ensure data sovereignty, realizing data availability within a single market, i.e., European Health Data Space (European Commission, 2022). At the national level, the National Initiative for AI-driven Advancements (NITD) operationalizes the progress of data spaces (acatech – National Academy of Science and Engineering, 2023a) as an outcome of the German Digital Strategy (Cabinet of Germany, 2022), i.e., Culture Data Space (acatech – National Academy of Science and Engineering, 2021, 2023b). Additionally, there is ongoing global cooperation in the field of the data economy interconnection of data infrastructures and data ecosystems (Braud et al., 2021; Tardieu, 2022). Collaborative initiatives expand beyond Europe and advancing notably in Asia, connecting European and Japanese data spaces (DATA-EX, 2023; IDSA, 2022b; NTT Corporation, 2022), establishment of Gaia-X Hubs in Korea and Japan (Bonfiglio, 2023; Tardieu, 2022), as well as the creation of IDSA Competence Centers in China (IDSA, 2022a). Current practical examples for data spaces are “EuProGigant” in the industrial domain (Dumss et al., 2021; EuProGigant, 2023), “Mobility Data Space” for mobility data (Drees et al., 2021; Mobility Data Space, 2023), and the “Catena-X” in the automotive sector (Catena-X, 2022, 2023). The overarching goal is to establish a federation among and within data spaces, with interoperability being a critical factor (Pettenpohl et al., 2022). Interestingly, the Mobility Data Space links existing data platforms to each other on national level (Pretzsch et al., 2022), effectively functioning as data space mesh (Drees et al., 2022; MaaS Alliance, 2022). Furthermore, PrepDSpace4Mobility lay the foundation for sharing securely mobility data across Europe (PrepDSpace4Mobility, 2023). However, our study can help to inform both providers and participants about how adoption can be achieved.

To summarize, the factors identified above need to be considered when developing a data space adoption framework. The framework aims to help organizations better evaluate the implementation of data spaces in their operations and ensure successful adoption. Overall, it is important to consider these various factors when assessing the potential for data space adoption. Based on our results, we offer a preliminary framework for exploring the adoption of data spaces. We suggest using the TOE-framework, which has been used in the literature on data platform adoption (De Prieelle et al., 2020). We assume that the proposed framework focuses on achieving the successful adoption of data spaces, with a focus on data sovereignty, when implementing data governance in the data ecosystem. We aim to provide a preliminary framework, by combining the innovation characteristics of data spaces with the results. The framework is based on the three dimensions suggested in the TOE framework: technological, organizational, and environmental (see Table 2). Due to the focus of this study, the identified factors cover all dimensions and may provide a holistic perspective. There appear to be certain factors that are associated with multiple aspects and cannot be clearly attributed to any one of them. Interestingly, the technological dimension only shows up in five of the factors we have considered. Although the literature has addressed many organizational factors, our SLR revealed only six. As this is a preliminary model, and mainly a collection of factors in relation to the TOE framework, interdependencies and possible inconsistencies have not been assessed.

Table 2: Preliminary data space adoption model related to dimensions of TOE (Tornatzky et al., 1990)

Preliminary data space adoption model and related factors		
Technological Factors	Organizational Factors	Environmental Factors
Relative advantage	Top management support	Data Governance
Compatibility	Technological resources	Mimetic pressure
Cost	Financial resources	Perceived platform value
Scalability	Humane resources	External Pressure
Security	Organization size	Trust
		Regulation

### CONCLUSION, LIMITATIONS & FUTURE RESEARCH

Due to the increasing importance of data spaces and the interest shown in this area by policymakers and global players, research on data spaces needs to increase. In this study, we presented approaches used to describe or explain platform adoption, so as to draw analogous conclusions for data space adoption. Based on our results, we offer a preliminary data space adoption model. The data space is an emerging research topic, so the results should not be considered definitive. Further research is necessary to gain more knowledge about the adoption of data spaces. In particular, there is no adoption model for data spaces in the existing literature. Overall, this work constitutes a starting point for further research on data space adoption. Based on our SLR, a model for explaining data space adoption can be developed. The preliminary framework we propose may also serve as a starting point of sorts as a starting point. However, this study admits of some limitations. First, the sample used for the analysis was rather small. The use of literature on platform adoption for theories in field of data spaces is also subject to some well-known limitations (Touboulic & Walker, 2015). Importing existing theories to understand the adoption of data space is appropriate, but must be done judiciously and with consideration (Amundson, 1998). Not all platform principles of B2C platforms can be easily transferred to the B2B context (Culotta & Duparc, 2022). With regard to the literature, to characterize specific domains and their platform use in more detail (De Reuver et al., 2018), i.e., specifically for data spaces. Second, the approaches identified represent only a fraction of the existing technology adoption models. Thus, studying other research areas, for example, might provide further insights. In order to assess the validity of the presented preliminary data space adoption model, we invite researchers to extend our investigation to obtain a more comprehensive understanding. However, the fact that our study focused on various platforms limits the generalizability of our results to data spaces. While this study reviews the literature from a perspective that a federated data space refers to a decentralized infrastructure for trustworthy data sharing, future research should examine similarities and differences of the identified factors. Further studies will aim to confirm the framework and identify other factors not mentioned in this preliminary framework. Finally, although we have laid the foundations for developing a framework for data space adoption, we have not yet commenced this process. This is in part because so few data spaces have been implemented, making it hard to evaluate such a model. Thus, as a next step, we hope to develop an initial conceptual framework, based on this study's findings.

### REFERENCES

- Abbas, A. E., Agahari, W., Van De Ven, M., Zuiderwijk, A., & De Reuver, M. (2021). Business Data Sharing through Data Marketplaces: A Systematic Literature Review. *Journal of Theoretical and Applied Electronic Commerce Research*, 16(7), 3321–3339. <https://doi.org/10.3390/jtaer16070180>
- Abbas, A. E., Ofè, H., Zuiderwijk, A., & De Reuver, M. (2022). Preparing Future Business Data Sharing via a Meta-Platform for Data Marketplaces: Exploring Antecedents and Consequences of Data Sovereignty. *35 Th Bled eConference Digital Restructuring and Human (Re)Action*, 571–586. <https://doi.org/10.18690/um.fov.4.2022.36>
- Abbas, A. E., Ofè, H., Zuiderwijk, A., & De Reuver, M. (2023). Toward Business Models for a Meta-Platform: Exploring Value Creation in the Case of Data Marketplaces. *Proceedings of the 56th Hawaii International Conference on System Sciences*. <https://hdl.handle.net/10125/103086>
- Abdelkafi, N., Raasch, C., Roth, A., & Srinivasan, R. (2019). Multi-sided platforms. *Electronic Markets*, 29(4), 553–559. <https://doi.org/10.1007/s12525-019-00385-4>
- acatech – National Academy of Science and Engineering. (2021). *Datenraum Kultur—Souveräne digitale kulturelle Infrastrukturen für Publikumsentwicklung und Zugänglichkeit*. [https://www.kultursekretariat.de/fileadmin/Dateien/Im\\_Dialog/2021\\_11\\_08\\_Fachtage\\_fuer\\_Kommunalpolitik\\_Fachrun\\_de\\_1\\_Datenraum\\_Kultur.pdf](https://www.kultursekretariat.de/fileadmin/Dateien/Im_Dialog/2021_11_08_Fachtage_fuer_Kommunalpolitik_Fachrun_de_1_Datenraum_Kultur.pdf)
- acatech – National Academy of Science and Engineering. (2023a). *National Initiative for AI-based Transformation to the Data Economy*. <https://en.acatech.de/project/national-initiative-data-economy/>
- acatech – National Academy of Science and Engineering. (2023b). *The Culture Data Space is growing: More than 90 institutions in Munich deliberate over the next steps*. <https://en.acatech.de/allgemein/the-culture-data-space-is-growing-more-than-90-institutions-in-munich-deliberate-over-the-next-steps/>
- Ajzen, I. (1991). The theory of planned behavior. *Organizational Behavior and Human Decision Processes*, 50(2), 179–211. [https://doi.org/10.1016/0749-5978\(91\)90020-T](https://doi.org/10.1016/0749-5978(91)90020-T)
- Akberdina, V., & Barybina, A. Z. (2021). Prerequisites and Principles of Digital Platformization of the Economy. In V. Kumar, J. Rezaei, V. Akberdina, & E. Kuzmin (Eds.), *Digital Transformation in Industry* (Vol. 44, pp. 37–48). Springer International Publishing. [https://doi.org/10.1007/978-3-030-73261-5\\_4](https://doi.org/10.1007/978-3-030-73261-5_4)



- Alhammedi, A., Stanier, C., & Eardley, A. (2015). The Determinants of Cloud Computing Adoption in Saudi Arabia. *Computer Science & Information Technology (CS & IT)*, 55–67. <https://doi.org/10.5121/csit.2015.51406>
- Al-Suqri, M. N., & Al-Aufi, A. S. (Eds.). (2015). *Information Seeking Behavior and Technology Adoption: Theories and Trends*. IGI Global. <https://doi.org/10.4018/978-1-4666-8156-9>
- Amundson, S. D. (1998). Relationships between theory-driven empirical research in operations management and other disciplines. *Journal of Operations Management*, 16(4), 341–359. [https://doi.org/10.1016/S0272-6963\(98\)00018-7](https://doi.org/10.1016/S0272-6963(98)00018-7)
- Arif, N., & Suzianti, A. (2019). Analysis of technology adoption for an mobile learning platform on generation Z in Indonesia. *Proceedings of the 5th International Conference on Communication and Information Processing*, 32–36. <https://doi.org/10.1145/3370000>
- Bakos, Y. (1998). The emerging role of electronic marketplaces on the Internet. *Communications of the ACM*, 41(8), 35–42.
- Bandura, A. (1986). *Social foundations of thought and action: A social cognitive theory*. Prentice-Hall.
- Bartelheimer, C., zur Heiden, P., Lüttenberg, H., & Beverungen, D. (2022). Systematizing the lexicon of platforms in information systems: A data-driven study. *Electronic Markets*, 32(1), 375–396. <https://doi.org/10.1007/s12525-022-00530-6>
- Beverungen, D., Hess, T., Köster, A., & Lehrer, C. (2022a). From private digital platforms to public data spaces: Implications for the digital transformation. *Electronic Markets*, 32(2), 493–501. <https://doi.org/10.1007/s12525-022-00553-z>
- Beverungen, D., Hess, T., Köster, A., & Lehrer, C. (2022b). From private digital platforms to public data spaces: Implications for the digital transformation. *Electronic Markets*, 32(2), 493–501.
- Bianco, V. D., Myllarniemi, V., Komssi, M., & Raatikainen, M. (2014). The Role of Platform Boundary Resources in Software Ecosystems: A Case Study. *2014 IEEE/IFIP Conference on Software Architecture*, 11–20. <https://doi.org/10.1109/WICSA.2014.41>
- Blesik, T., & Bick, M. (2016). Adoption Factors for Crowdsourcing Based Medical Information Platforms. In F. Lehner & N. Fteimi (Eds.), *Knowledge Science, Engineering and Management* (Vol. 9983, pp. 172–184). Springer International Publishing. [https://doi.org/10.1007/978-3-319-47650-6\\_14](https://doi.org/10.1007/978-3-319-47650-6_14)
- Bonfiglio, F. (2023). *Gaia-X - Zoom-in the Big Picture of the European Digital Ecosystem Future*. [https://gaia-x.eu/wp-content/uploads/2023/04/Gaia-X-Standard-deck\\_04042023.pdf](https://gaia-x.eu/wp-content/uploads/2023/04/Gaia-X-Standard-deck_04042023.pdf)
- Bouchbout, K., & Alimazighi, Z. (2008). A framework for identifying the critical factors affecting the decision to adopt and use inter-organizational information systems. *Proceedings of the World Academy of Science, Engineering and Technology*, 43, 338–345.
- Boumediene, R., & Kawalek, P. (2008). Predicting SMEs willingness to adopt ERP, CRM, SCM & e-procurement systems. *ECIS 2008 Proceedings. 115*. European Conference on Information Systems (ECIS).
- Braud, A., Fromentoux, G., Radier, B., & Le Grand, O. (2021). The Road to European Digital Sovereignty with Gaia-X and IDSA. *IEEE Network*, 35(2), Article 2. <https://doi.org/10.1109/MNET.2021.9387709>
- Brost, G. S., Huber, M., Weiß, M., Protsenko, M., Schütte, J., & Wessel, S. (2018). An ecosystem and iot device architecture for building trust in the industrial data space. *Proceedings of the 4th ACM Workshop on Cyber-Physical System Security*, 39–50.
- Bub, U. (2023). „Ein klares Geschäftsmodell für das Teilen von Daten in Data Spaces hat sich noch nicht herauskristallisiert“. *Wirtschaftsinformatik & Management*, 15(3), 191–193. <https://doi.org/10.1365/s35764-023-00483-1>
- Cabinet of Germany. (2022). *Digital Strategy—Creating Digital Values Together*. [https://digitalstrategie-deutschland.de/static/eb25ff71f36b8cf2d01418ded8ae3dc2/Digitalstrategie\\_EN.pdf](https://digitalstrategie-deutschland.de/static/eb25ff71f36b8cf2d01418ded8ae3dc2/Digitalstrategie_EN.pdf)
- Catena-X. (2022). *Catena-X Operating Model Whitepaper*. [https://catena-x.net/fileadmin/user\\_upload/Publikationen\\_und\\_WhitePaper\\_des\\_Vereins/CX\\_Operating\\_Model\\_Whitepaper\\_02\\_12\\_22.pdf](https://catena-x.net/fileadmin/user_upload/Publikationen_und_WhitePaper_des_Vereins/CX_Operating_Model_Whitepaper_02_12_22.pdf)
- Catena-X. (2023). *Catena-X General Presentation*. [https://catena-x.net/fileadmin/user\\_upload/Vereinsdokumente/Catena-X\\_general\\_presentation.pdf](https://catena-x.net/fileadmin/user_upload/Vereinsdokumente/Catena-X_general_presentation.pdf)
- Charmaz, K., & Belgrave, L. L. (2012). Qualitative interviewing and grounded theory analysis. In J. F. Gubrium, J. A. Holstein, A. B. Marvasti, & K. D. McKinney (Eds.), *The Sage handbook of interview research: The complexity of the craft* (2nd ed). SAGE.
- Chau, P. Y., & Tam, K. Y. (1997). Factors affecting the adoption of open systems: An exploratory study. *MIS Quarterly*, 21(1), 1–24. <https://doi.org/10.2307/249740>
- Chaudhary, S., & Suri, P. K. (2021). Framework for agricultural e-trading platform adoption using neural networks. *International Journal of Information Technology*, 13(2), 501–510. <https://doi.org/10.1007/s41870-020-00603-9>
- Culotta, C., & Duparc, E. (2022). *Dimensions of Digital B2B Platforms in Logistics – A White Spot Analysis*. Hawaii International Conference on System Sciences. <https://doi.org/10.24251/HICSS.2022.597>
- Curry, E. (2020). Dataspaces: Fundamentals, Principles, and Techniques. In E. Curry, *Real-time Linked Dataspaces* (pp. 45–62). Springer International Publishing. [https://doi.org/10.1007/978-3-030-29665-0\\_3](https://doi.org/10.1007/978-3-030-29665-0_3)
- Czvetkó, T., & Abonyi, J. (2023). Data sharing in Industry 4.0—AutomationML, B2MML and International Data Spaces-based solutions. *Journal of Industrial Information Integration*, 33, 100438. <https://doi.org/10.1016/j.jii.2023.100438>
- DATA-EX. (2023). *DATA-EX and Related Activities in Japan—Gaia-X / DATA-EX – The importance of digital ecosystems for digital sovereignty: Framework to create digital ecosystems*. [https://japan.ahk.de/filehub/deliverFile/fe360c55-77bd-45c7-a353-91c4b40da403/2271440/S3b-DATA-EX\\_and\\_Related\\_Activities\\_in\\_Japan\\_2271440.pdf](https://japan.ahk.de/filehub/deliverFile/fe360c55-77bd-45c7-a353-91c4b40da403/2271440/S3b-DATA-EX_and_Related_Activities_in_Japan_2271440.pdf)
- Davis, F. D., Bagozzi, R. P., & Warshaw, P. R. (1989). User acceptance of computer technology: A comparison of two theoretical models. *Management Science*, 35(8), 982–1003.

- De Prieelle, F., De Reuver, M., & Rezaei, J. (2020). The Role of Ecosystem Data Governance in Adoption of Data Platforms by Internet-of-Things Data Providers: Case of Dutch Horticulture Industry. *IEEE Transactions on Engineering Management*, 1–11. <https://doi.org/10.1109/TEM.2020.2966024>
- De Reuver, M., Ofe, H., Agahari, W., Abbas, A. E., & Zuiderwijk, A. (2022). The openness of data platforms: A research agenda. *Proceedings of the 1st International Workshop on Data Economy*, 34–41. <https://doi.org/10.1145/3565011.3569056>
- De Reuver, M., Sørensen, C., & Basole, R. C. (2018). The digital platform: A research agenda. *Journal of Information Technology*, 33(2), Article 2.
- Delgosha, M. S., & Hajiheydari, N. (2020). On-demand service platforms pro/anti adoption cognition: Examining the context-specific reasons. *Journal of Business Research*, 121, 180–194. <https://doi.org/10.1016/j.jbusres.2020.08.031>
- Deng, H., Duan, S. X., & Luo, F. (2019). Critical determinants for electronic market adoption: Evidence from Australian small- and medium-sized enterprises. *Journal of Enterprise Information Management*, 33(2), 335–352. <https://doi.org/10.1108/JEIM-04-2019-0106>
- Dmitrieva, E. I. (2020). Digital Platforms as a Base for Forming a Digital Economy. *Proceedings of the 2nd International Scientific and Practical Conference on Digital Economy (ISCDE 2020)*. 2nd International Scientific and Practical Conference on Digital Economy (ISCDE 2020), Yekaterinburg, Russia. <https://doi.org/10.2991/aebmr.k.201205.092>
- Drees, H., Kubitzka, D. O., Lipp, J., Pretzsch, S., & Langdon, C. S. (2021). *Mobility Data Space – First Implementation and Business Opportunities*. 27th ITS World Congress, Hamburg.
- Drees, H., Pretzsch, S., Heinke, B., Wang, D., & Schlueter Langdon, C. (2022). *Data Space Mesh: Interoperability of Mobility Data Spaces*. <https://dih.telekom.com/cms/assets/e930c2fe-b2ad-4183-86bb-27d0093f1a05.pdf>
- Dumss, S., Weber, M., Schwaiger, C., Sulz, C., Rosenberger, P., Bleicher, F., Grafinger, M., & Weigold, M. (2021). EuProGigant – A Concept Towards an Industrial System Architecture for Data-Driven Production Systems. *Procedia CIRP*, 104, 324–329. <https://doi.org/10.1016/j.procir.2021.11.055>
- EuProGigant. (2023). *EDGE COMPUTING IN THE EUPROGIGANT PROJECT*. [https://euprogigant.com/wp-content/uploads/2022/03/EuProGigant-Whitepaper\\_EN.pdf](https://euprogigant.com/wp-content/uploads/2022/03/EuProGigant-Whitepaper_EN.pdf)
- European Commission. (2018). *Towards a common European data space*. European Commission. <https://eur-lex.europa.eu/legal-content/EN/TXT/PDF/?uri=CELEX:52018DC0232&from=DE>
- European Commission. (2022). *REGULATION OF THE EUROPEAN PARLIAMENT AND OF THE COUNCIL on the European Health Data Space*. [https://eur-lex.europa.eu/resource.html?uri=cellar:dbfd8974-cb79-11ec-b6f4-01aa75ed71a1.0001.02/DOC\\_1&format=PDF](https://eur-lex.europa.eu/resource.html?uri=cellar:dbfd8974-cb79-11ec-b6f4-01aa75ed71a1.0001.02/DOC_1&format=PDF)
- European Commission. (2023). *European Data Strategy: Making the EU a role model for a society empowered by data*. [https://commission.europa.eu/strategy-and-policy/priorities-2019-2024/europe-fit-digital-age/european-data-strategy\\_en](https://commission.europa.eu/strategy-and-policy/priorities-2019-2024/europe-fit-digital-age/european-data-strategy_en)
- Fassnacht, M., Benz, C., Heinz, D., Leimstoll, J., & Satzger, G. (2023). Barriers to Data Sharing among Private Sector Organizations. *Proceedings of the 56th Hawaii International Conference on System Sciences*. Hawaii International Conference on Systems Sciences (HICSS). <https://hdl.handle.net/10125/103084>
- Fishbein, M., & Ajzen, I. (1975). Belief, attitude, intention and behavior reading, MA. *Addison-Wesley, Ford, RC & Richardson, WD (1994). Ethical Decision Making: A Review of the Empirical Literature. Journal of Business Ethics*, 13, 205–221.
- Franklin, M., Halevy, A., & Maier, D. (2005). From databases to dataspace: A new abstraction for information management. *ACM SIGMOD Record*, 34(4), Article 4. <https://doi.org/10.1145/1107499.1107502>
- Freire, M., Fortes, N., & Barbosa, J. (2014). Decisive factors for the adoption of technology in E-government platforms. *2014 9th Iberian Conference on Information Systems and Technologies (CISTI)*, 1–6. <https://doi.org/10.1109/CISTI.2014.6877042>
- Fruhworth, M., Rachinger, M., & Prlja, E. (2020). *Discovering Business Models of Data Marketplaces*. Hawaii International Conference on System Sciences. <https://doi.org/10.24251/HICSS.2020.704>
- Fu, H.-P., Chang, T.-H., Ku, C.-Y., Chang, T.-S., & Huang, C.-H. (2014). The critical success factors affecting the adoption of inter-organization systems by SMEs. *Journal of Business & Industrial Marketing*.
- Gangwar, H., Date, H., & Ramaswamy, R. (2015). Understanding determinants of cloud computing adoption using an integrated TAM-TOE model. *Journal of Enterprise Information Management*, 28(1), 107–130. <https://doi.org/10.1108/JEIM-08-2013-0065>
- Gawer, A. (2014). Bridging differing perspectives on technological platforms: Toward an integrative framework. *Research Policy*, 43(7), 1239–1249. <https://doi.org/10.1016/j.respol.2014.03.006>
- Gebregiorgis, S. A., & Altmann, J. (2015). IT Service Platforms: Their Value Creation Model and the Impact of their Level of Openness on their Adoption. *Procedia Computer Science*, 68, 173–187. <https://doi.org/10.1016/j.procs.2015.09.233>
- Gelhaar, J., Müller, P., Bergmann, N., & Dogan, R. (2023). Motives and incentives for data sharing in industrial data ecosystems: An explorative single case study. *Proceedings of the 56th Hawaii International Conference on System Sciences (HICSS)*. Hawaii International Conference on System Sciences (HICSS), Hawaii, USA. <https://hdl.handle.net/10125/103085>
- Gelhaar, J., & Otto, B. (2020). Challenges in the Emergence of Data Ecosystems. *Pacific Asia Conference on Information Systems (PACIS)*, 175.
- Gieß, A., Hupperz, M., Schoormann, T., & Möller, F. (2024). *What Does it Take to Connect? Unveiling Characteristics of Data Space Connectors*. Hawaii International Conference on System Sciences (HICSS).
- Gieß, A., Möller, F., Schoormann, T., & Otto, B. (2023). *Design options for data spaces*. Thirty-first European Conference on Information Systems (ECIS 2023).
- Giussani, G., & Steinbuss, S. (2023). *Data Connector Report (5.0)*. International Data Spaces Association. <https://doi.org/10.5281/ZENODO.7711222>

- Grover, V. (1993). An Empirically Derived Model for the Adoption of Customer-based Interorganizational Systems. *Decision Sciences*, 24(3), 603–640. <https://doi.org/10.1111/j.1540-5915.1993.tb01295.x>
- Guggenberger, T., Möller, F., Haarhaus, T., Gür, I., & Otto, B. (2020). Ecosystem Types in Information Systems. *ECIS*. Twenty-Eighth European Conference on Information Systems (ECIS2020), Marrakesh, Morocco.
- Guo, J., Cheng, Y., Wang, D., Tao, F., & Pickl, S. (2021). Industrial Dataspace for smart manufacturing: Connotation, key technologies, and framework. *International Journal of Production Research*, 1–16. <https://doi.org/10.1080/00207543.2021.1955996>
- Guo, X., Zhao, Y., Jin, Y., & Zhang, N. (2010). Two-Sided Adoption of Mobile Marketing Platforms: Towards an Integrated Conceptual Model. *2010 Ninth International Conference on Mobile Business and 2010 Ninth Global Mobility Roundtable (ICMB-GMR)*, 474–480. <https://doi.org/10.1109/ICMB-GMR.2010.53>
- Hagiu, A. (2007). Merchant or two-sided platform? *Review of Network Economics*, 6(2), Article 2.
- Hagiu, A., & Wright, J. (2015). Multi-Sided Platforms. *SSRN Electronic Journal*. <https://doi.org/10.2139/ssrn.2794582>
- Hallikainen, H., & Aunimo, L. (2020). Adoption of Digital Collaborative Networking Platforms in Companies: A Study of Twitter Usage in Finland. In L. M. Camarinha-Matos, H. Afsarmanesh, & A. Ortiz (Eds.), *Boosting Collaborative Networks 4.0* (Vol. 598, pp. 98–110). Springer International Publishing. [https://doi.org/10.1007/978-3-030-62412-5\\_8](https://doi.org/10.1007/978-3-030-62412-5_8)
- Harris, I., Wang, Y., & Wang, H. (2015). ICT in multimodal transport and technological trends: Unleashing potential for the future. *International Journal of Production Economics*, 159, 88–103. <https://doi.org/10.1016/j.ijpe.2014.09.005>
- Hasyati, Z., & Suzianti, A. (2018). Analysis of technology adoption for an online platform for development planning discussion. *Proceedings of the 4th International Conference on Communication and Information Processing - ICCIP '18*, 150–155. <https://doi.org/10.1145/3290420.3290434>
- Hein, A., Weking, J., Schreieck, M., Wiesche, M., Böhm, M., & Krcmar, H. (2019). Value co-creation practices in business-to-business platform ecosystems. *Electronic Markets*, 29(3), Article 3. <https://doi.org/10.1007/s12525-019-00337-y>
- Hirsch-Kreinsen, H., Kubach, U., Stark, R., von Wichert, G., Litsche, S., Sedlmeier, J., & Steglich, S. (2022). *Themenfelder Industrie 4.0: Forschungs-und Entwicklungsbedarfe zur erfolgreichen Umsetzung von Industrie 4.0* (2). Forschungsbeirat der Plattform Industrie 4.0/acatech – Deutsche Akademie der Technikwissenschaften.
- Hong, J., Guo, P., Deng, H., & Quan, Y. (2021). The adoption of supply chain service platforms for organizational performance: Evidences from Chinese catering organizations. *International Journal of Production Economics*, 237, 108147. <https://doi.org/10.1016/j.ijpe.2021.108147>
- Hong, S., Thong, J. Y. L., & Tam, K. Y. (2006). Understanding continued information technology usage behavior: A comparison of three models in the context of mobile internet. *Decision Support Systems*, 42(3), 1819–1834. <https://doi.org/10.1016/j.dss.2006.03.009>
- Hupperz, M., & Gieß, A. (2024). *The Interplay of Data-Driven Organizations and Data Spaces: Unlocking Capabilities for Transforming Organizations in the Era of Data Spaces*. Hawaii International Conference on System Sciences (HICSS).
- Hutterer, A., & Krumay, B. (2022). Integrating Heterogeneous Data in Dataspaces—A Systematic Mapping Study. *PACIS 2022 Proceedings*. Pacific Asia Conference on Information Systems (PACIS). <https://aisel.aisnet.org/pacis2022/222>
- Hutterer, A., Krumay, B., & Mühlburger, M. (2023). What Constitutes a Data space? Conceptual Clarity beyond Technical Aspects. *29th Americas Conference on Information Systems (AMCIS)*. Americas Conference on Information Systems (AMCIS), Panama. [https://aisel.aisnet.org/amcis2023/eco\\_systems/eco\\_systems/5](https://aisel.aisnet.org/amcis2023/eco_systems/eco_systems/5)
- Iacovou, C. L., Benbasat, I., & Dexter, A. S. (1995). Electronic data interchange and small organizations: Adoption and impact of technology. *MIS Quarterly*, 465–485.
- IDSA. (2019). *IDS – A standard for data sovereignty and indispensable element of data ecosystems*. International Data Space Association. <https://internationaldataspaces.org/wp-content/uploads/IDSA-Brochure-IDS-Standard-for-Data-Sovereignty-Indispensable-Element-for-Data-Ecosystems.pdf>
- IDSA. (2022a). *IDSA establishes China Competence Center: Strengthening international data sharing and collaboration*. <https://internationaldataspaces.org/idsa-establishes-china-competence-center-strengthening-international-data-sharing-and-collaboration/>
- IDSA. (2022b). *Joint development between Japan and Europe in data sovereignty*. <https://internationaldataspaces.org/joint-development-between-japan-and-europe-in-data-sovereignty/>
- IDSA. (2022c). *Reference Architecture Model, Version 4.0*. <https://docs.internationaldataspaces.org/ids-ram-4/>
- Ilin, V., Ivetić, J., & Simić, D. (2017). Understanding the determinants of e-business adoption in ERP-enabled firms and non-ERP-enabled firms: A case study of the Western Balkan Peninsula. *Technological Forecasting and Social Change*, 125, 206–223. <https://doi.org/10.1016/j.techfore.2017.07.025>
- Jeyaraj, A., Rottman, J. W., & Lacity, M. C. (2006). A review of the predictors, linkages, and biases in IT innovation adoption research. *Journal of Information Technology*, 21(1), 1–23.
- Jürjens, J., Scheider, S., Yildirim, F., & Henke, M. (2022). Tokenomics: Decentralized incentivization in the context of data spaces. *Designing Data Spaces*, 91.
- Jussen, I., Schweihoff, J., Dahms, V., Möller, F., & Otto, B. (2023). Data Sharing Fundamentals: Definition and Characteristics. *Proceedings of the 56th Hawaii International Conference on System Sciences (HICSS)*, 3685–3694. <https://hdl.handle.net/10125/103083>
- Kamal, S. A., Shafiq, M., & Kakria, P. (2020). Investigating acceptance of telemedicine services through an extended technology acceptance model (TAM). *Technology in Society*, 60, 101212. <https://doi.org/10.1016/j.techsoc.2019.101212>
- Kenney, M., & Zysman, J. (2016). The rise of the platform economy. *Issues in Science and Technology*, 32(3), 61.

- Khasawneh, A. M. (2008). Concepts and measurements of innovativeness: The case of information and communication technologies. *International Journal of Arab Culture, Management and Sustainable Development*, 1(1), 23–33. <https://dx.doi.org/10.1504/IJACMSD.2008.020487>
- Konana, P., & Balasubramanian, S. (2005). The Social–Economic–Psychological model of technology adoption and usage: An application to online investing. *Decision Support Systems*, 39(3), 505–524. <https://doi.org/10.1016/j.dss.2003.12.003>
- Koul, S., & Eydgahi, A. (2018). Utilizing Technology Acceptance Model (TAM) for driverless car technology Adoption. *Journal of Technology Management & Innovation*, 13(4), 37–46. <https://doi.org/10.4067/S0718-27242018000400037>
- Koutroumpis, P., Leiponen, A., & Thomas, L. D. (2017). *The (unfulfilled) potential of data marketplaces*. ETLA working papers.
- Kuan, K. K., & Chau, P. Y. (2001). A perception-based model for EDI adoption in small businesses using a technology–organization–environment framework. *Information & Management*, 38(8), 507–521.
- Kurnia, S., Karnali, R. J., & Rahim, M. M. (2015). A qualitative study of business-to-business electronic commerce adoption within the Indonesian grocery industry: A multi-theory perspective. *Information & Management*, 52(4), 518–536. <https://doi.org/10.1016/j.im.2015.03.003>
- Kurniawan, R. (2019). Examination of the factors contributing to financial technology adoption in Indonesia using technology acceptance model: Case study of peer to peer lending service platform. *2019 International Conference on Information Management and Technology (ICIMTech)*, 1, 432–437.
- Kwon, T. H., & Zmud, R. W. (1987). Unifying the fragmented models of information systems implementation. In *Critical issues in information systems research* (pp. 227–251).
- Lai, K., Wong, C. W. Y., & Cheng, T. C. E. (2006). Institutional isomorphism and the adoption of information technology for supply chain management. *Computers in Industry*, 57(1), 93–98. <https://doi.org/10.1016/j.compind.2005.05.002>
- Lin, D., Lee, C. K. M., & Lin, K. (2016). Research on effect factors evaluation of internet of things (IOT) adoption in Chinese agricultural supply chain. *2016 IEEE International Conference on Industrial Engineering and Engineering Management (IEEM)*, 612–615. <https://doi.org/10.1109/IEEM.2016.7797948>
- Lippert, S. K., & Govindarajulu, C. (2006). Technological, organizational, and environmental antecedents to web services adoption. *Communications of the IIMA*, 6(1), 14.
- Low, C., Chen, Y., & Wu, M. (2011). Understanding the determinants of cloud computing adoption. *Industrial Management & Data Systems*.
- MaaS Alliance. (2022). *MOBILITY DATA SPACES AND MAAS*. <https://maas-alliance.eu/wp-content/uploads/2022/10/MaaS-Alliance-Whitepaper-on-Mobility-Data-Spaces-1.pdf>
- Minghini, M., Kotsev, A., & Granell, C. (2022). A European Approach to the Establishment of Data Spaces. *Data*, 7(8), 118. <https://doi.org/10.3390/data7080118>
- Miranda, M., Ferreira, R., de Souza, C. R. B., Figueira Filho, F., & Singer, L. (2014). An exploratory study of the adoption of mobile development platforms by software engineers. *Proceedings of the 1st International Conference on Mobile Software Engineering and Systems - MOBILESoft 2014*, 50–53. <https://doi.org/10.1145/2593902.2593915>
- Mobility Data Space. (2023). *Mobility Data Space: Data Sharing Community*. [https://mobility-dataspace.eu/fileadmin/05\\_presse\\_medien/2023-08-30\\_MDS\\_PitchDeck\\_EN.pdf](https://mobility-dataspace.eu/fileadmin/05_presse_medien/2023-08-30_MDS_PitchDeck_EN.pdf)
- Moore, G. C., & Benbasat, I. (1991). Development of an instrument to measure the perceptions of adopting an information technology innovation. *Information Systems Research*, 2(3), 192–222.
- NTT Corporation. (2022). *NTT Com and NTT DATA to Develop Data-sharing Eco-system that Interconnects with Europe's Catena-X Platform to Protect Data Sovereignty*. <https://www.ntt.com/en/about-us/press-releases/news/article/2022/0526.html>
- Ocean Protocol Foundation. (2022). *Ocean Protocol: Tools for the Web3 Data Economy*. Ocean Protocol Foundation. <https://oceanprotocol.com/tech-whitepaper.pdf>
- Oliveira, T., & Martins, M. F. (2011). Literature review of information technology adoption models at firm level. *Electronic Journal of Information Systems Evaluation*, 14(1), pp110-121.
- Oliveira, T., Thomas, M., & Espadanal, M. (2014). Assessing the determinants of cloud computing adoption: An analysis of the manufacturing and services sectors. *Information & Management*, 51(5), 497–510. <https://doi.org/10.1016/j.im.2014.03.006>
- Otto, B. (2022). The evolution of data spaces. In *Designing Data Spaces: The Ecosystem Approach to Competitive Advantage* (pp. 3–15). Springer International Publishing Cham.
- Otto, B., Auer, S., Cirullies, J., Jürjens, J., Menz, N., Schon, J., & Wenzel, S. (2016). *Industrial Data Space: Digital Sovereignty Over Data*. <https://doi.org/10.13140/RG.2.1.2673.0649>
- Otto, B., Bärenfänger, R., & Steinbuß, S. (2015). Digital business engineering: Methodological foundations and first experiences from the field. *BLED 2015 Proceedings*. 13. 28th Bled eConference, Bled. <https://aisel.aisnet.org/bled2015/13>
- Otto, B., & Jarke, M. (2019a). Designing a multi-sided data platform: Findings from the International Data Spaces case. *Electronic Markets*, 29(4), Article 4.
- Otto, B., & Jarke, M. (2019b). Designing a multi-sided data platform: Findings from the International Data Spaces case. *Electronic Markets*, 29(4), 561–580.
- Özcan, L., Koldewey, C., Duparc, E., van der Valk, H., Otto, B., & Dumitrescu, R. (2022). Why do digital platforms succeed or fail? - A literature review on success and failure factors. *AMCIS 2022 Proceedings*. 15. Americas Conference on Information Systems (AMCIS). [https://aisel.aisnet.org/amcis2022/sig\\_dite/sig\\_dite/15](https://aisel.aisnet.org/amcis2022/sig_dite/sig_dite/15)
- Pauli, T., Fielt, E., & Matzner, M. (2021a). Digital industrial platforms. *Business & Information Systems Engineering*, 63(2), 181–190.

- Pauli, T., Fielt, E., & Matzner, M. (2021b). Digital Industrial Platforms. *Business & Information Systems Engineering*, 63(2), 181–190. <https://doi.org/10.1007/s12599-020-00681-w>
- Pettenpohl, H., Spiekermann, M., & Both, J. R. (2022). International data spaces in a nutshell. *Designing Data Spaces; Springer: Cham, Switzerland*, 29–40.
- Pontus-X. (2023). *Pontus-X Documentation*. <https://docs.genx.minimal-gaia-x.eu/docs/intro>
- Premkumar, G., & Ramamurthy, K. (1995). The Role of Interorganizational and Organizational Factors on the Decision Mode for Adoption of Interorganizational Systems. *Decision Sciences*, 26(3), 303–336. <https://doi.org/10.1111/j.1540-5915.1995.tb01431.x>
- PrepDSpace4Mobility. (2023). *Preparatory action to establish a common European data space for mobility*. <https://mobilitydataspace-csa.eu/wp-content/uploads/2023/07/psf-27-june.pdf>
- Pretzsch, S., Drees, H., & Rittershaus, L. (2022). Mobility Data Space: A Secure Data Space for the Sovereign and Cross-Platform Utilization of Mobility Data. In B. Otto, M. Ten Hompel, & S. Wrobel (Eds.), *Designing Data Spaces* (pp. 343–361). Springer International Publishing. [https://doi.org/10.1007/978-3-030-93975-5\\_21](https://doi.org/10.1007/978-3-030-93975-5_21)
- Provan, K. G., & Kenis, P. (2007). Modes of Network Governance: Structure, Management, and Effectiveness. *Journal of Public Administration Research and Theory*, 18(2), 229–252. <https://doi.org/10.1093/jopart/mum015>
- Rahimi, B., Nadri, H., Lotfnezhad Afshar, H., & Timpka, T. (2018). A Systematic Review of the Technology Acceptance Model in Health Informatics. *Applied Clinical Informatics*, 09(03), 604–634. <https://doi.org/10.1055/s-0038-1668091>
- Reyes, P. M., Li, S., & Visich, J. K. (2016). Determinants of RFID adoption stage and perceived benefits. *European Journal of Operational Research*, 254(3), 801–812. <https://doi.org/10.1016/j.ejor.2016.03.051>
- Rogers, E. (1995). Diffusion of innovations. *New York: Free Press of Glencoe*, 4. <http://www.lamolina.edu.pe/postgrado/pmdas/cursos/innovacion/lecturas/Obligatoria/17%20-%20Rogers%201995%20cap%206.pdf>
- Rui, G. (2007). *Information systems innovation adoption among organizations-A match-based framework and empirical studies* [Doctoral Thesis]. National University of Singapore.
- Schleimer, A. M., Fraunhofer, I., Jahnke, N., & Otto, B. (2023). Architecture Design Options for Federated Data Spaces. *Proceedings of the 56th Hawaii International Conference on System Sciences*. Hawaii International Conference on System Sciences (HICCS). <https://hdl.handle.net/10125/103078>
- Schmid, B. F., & Lindemann, M. A. (1998). Elements of a reference model for electronic markets. *Proceedings of the Thirty-First Hawaii International Conference on System Sciences*, 4, 193–201.
- Scholten, J. (2017). *The determinants of cloud computing adoption in The Netherlands: A TOE-perspective* [Master's Thesis]. University of Twente.
- Schweihoff, J. C., Jussen, I., & Möller, F. (2023). Trust me, I'm an Intermediary! Exploring Data Intermediation Services. *Proceedings of the 18th International Conference on Wirtschaftsinformatik*. International Conference on Wirtschaftsinformatik. <https://aisel.aisnet.org/wi2023/23>
- Shim, S., Lee, B., & Kim, S. L. (2018). Rival precedence and open platform adoption: An empirical analysis. *International Journal of Information Management*, 38(1), 217–231. <https://doi.org/10.1016/j.ijinfomgt.2017.10.001>
- Singh, A., Sharma, S., & Paliwal, M. (2021). Adoption intention and effectiveness of digital collaboration platforms for online learning: The Indian students' perspective. *Interactive Technology and Smart Education*, 18(4), 493–514. <https://doi.org/10.1108/ITSE-05-2020-0070>
- Singh, M., & Jain, S. K. (2011). A Survey on Dataspace. In D. C. Wyld, M. Wozniak, N. Chaki, N. Meghanathan, & D. Nagamalai (Eds.), *Advances in Network Security and Applications* (Vol. 196, pp. 608–621). Springer Berlin Heidelberg. [https://doi.org/10.1007/978-3-642-22540-6\\_59](https://doi.org/10.1007/978-3-642-22540-6_59)
- Sivathanu, B. (2019). Adoption of Industrial IoT (IIoT) in Auto-Component Manufacturing SMEs in India. *Information Resources Management Journal*, 32(2), 52–75. <https://doi.org/10.4018/IRMJ.2019040103>
- Song, J., Baker, J., Wang, Y., Choi, H. Y., & Bhattacharjee, A. (2018). Platform adoption by mobile application developers: A multimethodological approach. *Decision Support Systems*, 107, 26–39. <https://doi.org/10.1016/j.dss.2017.12.013>
- Spiekermann, M. (2019). Data Marketplaces: Trends and Monetisation of Data Goods. *Intereconomics: Review of European Economic Policy*, 54(4), 208–216. <https://doi.org/10.1007/s10272-019-0826-z>
- Stahl, F., Schomm, F., & Vossen, G. (2014). *The data marketplace survey revisited* (ERCIS Working Paper 18). ERCIS - European Research Center for Information Systems. <http://hdl.handle.net/10419/94187>
- Steinbuss, S., de Roode, M., Papakosta, S., Klinker, P., Punter, M., & Jimenez, S. (2023). *Data Spaces Landscape – Overview and relations of data spaces initiatives, standards, and tools (1.0)*.
- Steiner, M., Wiegand, N., Eggert, A., & Backhaus, K. (2016). Platform adoption in system markets: The roles of preference heterogeneity and consumer expectations. *International Journal of Research in Marketing*, 33(2), 276–296. <https://doi.org/10.1016/j.ijresmar.2015.05.011>
- Stieglitz, S., Mirbabaie, M., Fromm, J., & Melzer, S. (2018). The Adoption of social media analytics for crisis management—Challenges and Opportunities. *ECIS 2018 Proceedings*, 4. [https://aisel.aisnet.org/ecis2018\\_rp/4](https://aisel.aisnet.org/ecis2018_rp/4)
- Strnadl, C., & Schöning, H. (2023). Data platforms, Data Spaces, and (Data-)Ecosystems [Manuscript in preparation]. In *Data Governance*. Weber (Ed.); Springer.
- Sun, S., Cegielski, C. G., Jia, L., & Hall, D. J. (2018). Understanding the Factors Affecting the Organizational Adoption of Big Data. *Journal of Computer Information Systems*, 58(3), 193–203. <https://doi.org/10.1080/08874417.2016.1222891>



- Susha, I., Janssen, M., & Verhulst, S. (2017). *Data Collaboratives as a New Frontier of Cross-Sector Partnerships in the Age of Open Data: Taxonomy Development*. Hawaii International Conference on System Sciences. <https://doi.org/10.24251/HICSS.2017.325>
- Swanson, E. B. (1994). Information systems innovation among organizations. *Management Science*, 40(9), 1069–1092. <https://doi.org/10.1287/mnsc.40.9.1069>
- Syafinal, A. A., & Suzianti, A. (2019). Analyzing adoption factors of booking service platform for sport facilities with technology continuance theory model. *Proceedings of the 5th International Conference on Communication and Information Processing*, 174–178. <https://doi.org/10.1145/3369985.3369996>
- Tamilmani, K., Rana, N. P., Nunkoo, R., Raghavan, V., & Dwivedi, Y. K. (2020). Indian Travellers' Adoption of Airbnb Platform. *Information Systems Frontiers*. <https://doi.org/10.1007/s10796-020-10060-1>
- Tardieu, H. (2022). Role of Gaia-X in the European Data Space Ecosystem. In *Designing Data Spaces: The Ecosystem Approach to Competitive Advantage* (pp. 41–59). Springer International Publishing Cham.
- Tomičić-Pupek, K., Pihir, I., & Furjan, M. T. (2020). The Role of Perception in the Adoption of Digital Platforms in Agriculture. *2020 43rd International Convention on Information, Communication and Electronic Technology (MIPRO)*, 1429–1434.
- Tornatzky, L. G., Fleischer, M., & Chakrabarti, A. K. (1990). *Processes of technological innovation*. Lexington books.
- Touboulic, A., & Walker, H. (2015). Theories in sustainable supply chain management: A structured literature review. *International Journal of Physical Distribution & Logistics Management*, 45(1/2), 16–42. <https://doi.org/10.1108/IJPDLM-05-2013-0106>
- Van Den Broek, T., & Van Veenstra, A. F. (2015). Modes of Governance in Inter-Organizational Data Collaborations. *ECIS 2015 Proceedings*. European Conference on Information Systems (ECIS). <https://doi.org/10.18151/7217509>
- Venkatesh, V., & Davis, F. D. (2000). A theoretical extension of the technology acceptance model: Four longitudinal field studies. *Management Science*, 46(2), 186–204.
- Venkatesh, V., Morris, M. G., Davis, G. B., & Davis, F. D. (2003). User acceptance of information technology: Toward a unified view. *MIS Quarterly*, 425–478.
- Wang, Y.-M., Wang, Y.-S., & Yang, Y.-F. (2010). Understanding the determinants of RFID adoption in the manufacturing industry. *Technological Forecasting and Social Change*, 77(5), 803–815.
- Xie, J., Ye, L., Huang, W., & Ye, M. (2021). Understanding FinTech Platform Adoption: Impacts of Perceived Value and Perceived Risk. *Journal of Theoretical and Applied Electronic Commerce Research*, 16(5), 1893–1911. <https://doi.org/10.3390/jtaer16050106>
- Yanagisawa, T., & Guellec, D. (2009). *The Emerging Patent Marketplace* (OECD Science, Technology and Industry Working Papers 2009/09). Organisation for Economic Co-operation and Development. <https://doi.org/10.1787/218413152254>
- Yang, T.-M., & Maxwell, T. A. (2011). Information-sharing in public organizations: A literature review of interpersonal, intra-organizational and inter-organizational success factors. *Government Information Quarterly*, 28(2), 164–175. <https://doi.org/10.1016/j.giq.2010.06.008>
- Yoffie, D. B., Gawer, A., & Cusumano, M. A. (2019). A study of more than 250 platforms a reveal why most fail. *Harvard Business Review*. <https://hbr.org/2019/05/a-study-of-more-than-250-platforms-reveals-why-most-fail>
- Zeng, F., Chan, H. K., & Pawar, K. (2020). The adoption of open platform for container bookings in the maritime supply chain. *Transportation Research Part E: Logistics and Transportation Review*, 141, 102019. <https://doi.org/10.1016/j.tre.2020.102019>
- Zhu, K., Kraemer, K., & Xu, S. (2003). Electronic business adoption by European firms: A cross-country assessment of the facilitators and inhibitors. *European Journal of Information Systems*, 12(4), 251–268. <https://doi.org/10.1057/palgrave.ejis.3000475>
- Zhu, K., Xu, S., & Dedrick, J. (2003). Assessing drivers of e-business value: Results of a cross-country study. *ICIS 2003 Proceedings*, 16.
- Zuiderwijk, A., Loukis, E., Alexopoulos, C., Janssen, M., & Jeffery, K. (2014). Elements for the development of an open data marketplace. *Proceedings of the International Conference for E-Democracy and Open Government*, 309–322.

## AI and Firm Competitiveness

John R. Hamilton <sup>1,\*</sup>  
Singwhat Tee <sup>2</sup>  
Stephen J. Maxwell <sup>3</sup>

---

\*Corresponding author

<sup>1</sup> Adj. Chair Professor, James Cook University, Cairns, Australia, John.Hamilton@jcu.edu.au

<sup>2</sup> Senior Lecturer, Doctor, James Cook University, Cairns, Australia, Singwhat.Tee@jcu.edu.au

<sup>3</sup> Researcher, Doctor, James Cook University, Cairns, Australia, Stephen.Maxwell@my.jcu.edu.au

### ABSTRACT

The inclusion of artificial intelligence (AI) can alter firm competitiveness through data analysis and strategic planning modelling. In this paper we demonstrate that firm AI inclusion is literature supported as a stage-wise, developmental, intelligences-driven, change process. Identified benefits that AI inclusion may bring to the firm: (1) a knowledge-driven competencies and capabilities collation, (2) engaging innovative digital deep-learning, along with (3) robust stage-wise interpretations. These AI actioning effects ultimately network, and coalesce, and can deliver beneficial changes towards altering the existing firm competitiveness positioning. An AI deliverance framework with AI feedback loops is presented which demonstrates that AI can provide a competitive advantage in the global workplace.

*Keywords:* Artificial Intelligence, Capabilities, Competencies, Creative Knowledge, Digital Technologies, Innovation, Intellectual Capital, Firm AI

### INTRODUCTION

#### Artificial Intelligence (AI) and the Firm

AI captures the analysis of substantive firm captured data sets, identifies embedded patterns, and likely offers intelligent solutions. AI can assist a firm in: decision making, creating greater firm operational efficiencies, minimize risks, delivering firm personalized experiences to the marketplace, and in pursuing firm ongoing competitiveness. In firms, AI, and/or learning machines, and/or autonomous robots, can each mimic aspects of human intelligence. Yet each provides different task performance capabilities, and each can in some way complement the other's solution aspects (Varmavuo, 2020). AI considers complexities, and can assess and utilize these as it seeks to enhance net intelligences of firm products, firm services, or specific firm solutions (Shankar, 2018). In contrast, when compared to most intelligent machines and autonomous robots, humans in the workforce can provide creative, holistic and intuitive solutions. AI also offers intelligent, near error-free data derived solutions to complex organisational problems (Vishoi *et al.*, 2018). Hence, as AI rapidly analyses complex data and trends, it can also generate further accuracies and further insights across its solutions to maximize workplace productivity,

Currently AI, incorporated at the firm level, resides within a technology-firm-environment framework, and with diffusion of innovation theory (AlSheibani *et al.*, 2020). AI inclusion also links the firm and its business across a raft of theories including: theory of reasoned action, resource-based theory, competitive advantage theory, decision theory, motivated reasoning theory, theory of motivated reasoning, uncertainty reduction theory, value chain theory, and voice of the customer theory (Debnath & Mukhopadhyay, 2016). Further, firms can specifically pursue AI as further enablers towards their competitiveness position. For example, firms may include AI when aiming to move faster, sharpen predictions, boost efficiencies and optimize real-time product pricing and stock minimization, and blue-ocean position against rivals (Townson, 2021). Thus AI and its inclusion fits into an important firm modelling theoretical framework.

Krakowski *et al.* (2023) follow a resource-based perspective where AI and its effects across competitive capabilities and as a performance (competitiveness) outcome is mapped and explored. They show AI adoption triggers new resource dynamics, and typically make a traditional human workforce's competitive capabilities obsolete, whilst creating a new AI-based decision-making resource, along with generating new workforce-machine capabilities. Such heterogeneous interactions in-turn also create a dynamic shift in the firm's performance (competitiveness) position. Thus firms adopting AI likely find changes to prior sources of competitive advantage, and this likely requires new relevant AI-based capabilities to become performance engaged. Rowland *et al.* (2022) see AI and digital transformation as a natural operational choice tension. AI first determines successful competitive contributions. AI inclusion brings opportunities across emerging new technologies to further explore and exploit additional technologies-related approaches - that can in-turn: (1) embed values - such as improvements in connectivities, and knowledge (qualities), operational efficiencies (performance), productive engagement levels (economic worth), (2) deliver new significant pathway systems, and (3) execute beneficial digital transformations that offer enhanced overall firm competitiveness.

AI captures ‘narrow solutions’ like accuracy-of-prediction to augment human efforts, through to ‘broad solutions’ delivering integrated machine learning capabilities and recommendations (Davenport et al., 2021). The mapping a ‘situated AI’ pathway provides model perspectives of how AI helps drive a competitiveness position (Kemp, 2023). Kemp’s (2023) grounding, bounding, and recasting approach to AI firm activities (competencies) likely better enables the firm towards developing AI-supports capabilities that are: firm specific, cost effective, and appropriate for the opportunities arising in the strategic marketplace. Similarly, knowledge sharing (capacities and intellectual capital [IP]), plus market-orientated IT (creative technologies) competences support an innovative firm orientation (innovativeness) that blends with current firm innovativeness (values deliverance) (Singh et al., 2022). These then coalesce, and further enable an ongoing (sustainable) competitively advantageous (competitiveness) position - along with a specific consumer/marketplace orientation. Therefore, AI is an intelligent feedback system capable of rapidly advancing improvement solutions to the current data situation and the firm’s competitiveness (Davenport et al., 2021; Singh et al., 2022; Kemp, 2023). AI knowledge information capacities across available data systems as intelligent business systems (competencies) that can positively engage towards improving firm process performances (capabilities), and these in-turn can positively impact on the existing competitiveness position (Wang et al., 2023). The existence of an AI competencies to capabilities to competitiveness three stage developmental process, and like other \_ third generation AI studies (Zhang et al., 2023), this process has structural feedback loops operating (Figure 1).

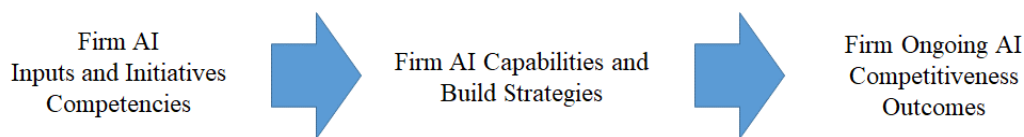

Figure 1: Three stage AI deliverance.

### Research Agenda

This study’s research agenda assesses whether the AI deployed by firms can model Figure 1 to gauge the deliverance of overall competitiveness into the future. Hence, this study asks, at the firm- level: ‘can AI competencies and capabilities together model towards delivering a dynamic AI-enhancing competitiveness position?’ We answer this with the presentation of a AI deliverance framework and modelling approach first assesses firm AI inputs and initiatives including: IP capacities, technologies knowledge creation, and VRIO innovation as three key competencies readiness determinants. These inputs and initiatives covary and frame towards supporting firm operational AI values, risk, marketplace serving and communicative connectivities capabilities and their build strategies. Collectively these construct areas strategically build supportive relational systems that typically network-coalesce towards delivering ongoing firm AI-related outcomes - gauged as the firm’s ongoing (sustainable) AI-enhancing competitiveness positioning.

## LITERATURE REVIEW

### AI and Firm Input and Initiative Competencies

AI competencies provide computational agents that act intelligently whilst solving complex, time-consuming problems - sometimes akin to human cognitive intelligence processes (Makalef et al., 2023). This is achieved through the focus of AI technologies on pre-determined data and information requirements. AI systems learn, provide inferences, and leverage real-time data, that are aimed towards delivering operational and related firm-value benefits to the firms operations (Collins et al., 2021; Makarius et al., 2020). The conceptual view of competencies offered by Prahalad (1993) is supported by Mikalef et al., (2023) who argue competencies must address: (1) knowledge creative technologies offering technical abilities to differentiate; (2) IP capacities to support a raft of firm operations and processes; and (3) VRIO innovations to dynamically keep the firm proactively hard to imitate.

A firm is a ‘for-profit’ business entity. It is established to operate in-perpetuity, and over-time aims to grow its marketplace share. A new firm establishes so it can take unique input ideas and/or new initiative alternatives to the marketplace. When compared to its rivals, the firm strategizes its competencies to deliver such new initiative alternatives at greater efficiency, and/or lower cost. Thus, the new firm plans a fresh, differentiated entry into the marketplace. The new firm’s competencies draw upon its current intellectual property capacities, its existing technologies knowledge creation dimensions, and the existing resourcing innovations it can apply. The new firm’s differentiated competencies help it strategically support and build optimal capabilities sets of actioned, efficient, effective, and logical new product/service offerings with suitable sales appeal the firm’s chosen marketplace. The firm aims for its unique ideas and initiatives to provide an ongoing AI-enhancing competitiveness position against its rivals.

A firm collects its required and initiative alternatives as supply-side inputs. These frame the competencies required by the firm to support its ongoing business operations. Business operations that move into the digital domain, facilitate large data capture, and with this comes the opportunity to integrate AI. Firm supply-side inputs build around the firm’s capacities to collect and integrate inputs into a unique product, service or data-related intellectual property solution - typically of competitive use to the consumer and/or the marketplace. Similarly, the firm also captures technologies and innovations that offer it potential benefit and incorporates these as another input parameter. Further, the firm AI inclusion solutions also possess a unique mix of valuable, rare, inimitable, and firm organizational knowledge creation resources.

### ***Firm AI IP Capacities***

AI firm IP capacities represent the AI competence suite developed over time to support the continual-maintenance of a productive, valuable, operational business. IP offers patent protection and so provides a uniqueness or competitive-edge over rivals. It stops rivals copying, manufacturing, using, or selling the firm's product, service or artificial intelligences. The infusion of AI (and likely with machine learning [ML] support) add an IP capacities competency to quickly and accurately capture, process and analyse, the diverse, extensive, differentiated data sets available, and to provide real-time data-driven solutions and decisions against real-time, profitability-assessed insights.

Intellectual capital (IP), along with innovations in marketplace servicing capabilities, can enhance the current competitiveness position of a firm (Alkhatib & Valeri, 2022). Firms adopting AI that affected competitive capabilities, also found that these innovations also affected performance-related (competitiveness) outcomes (Krakowski et al., 2023). AI absorptive capacities moderate effects of engaged process and resource optimization of the servitization (service-centric business logistical models) (Abou-Foul et al., 2023). Therefore, inclusion of AI IP capacities contribute towards capacities to build further operational efficiencies, market offerings, consumer experiences, and socially engaging innovations. Thus the firm AI IP capacities are a set of competencies, that influence the AI capabilities being actioned, and collectively these likely affect the firm's AI-enhancing competitiveness positioning.

### ***Firm AI Technologies Knowledge Creation***

AI firm technologies knowledge creation is the AI competence suite required to initiate, support, and retain a competitive business edge. Technologies that AI-supported knowledge creation is useful in transforming, adapting and solving business communication processes from an accumulation, dissemination and effectively-used knowledge management perspective (Iaia et al., 2023). Thus AI technologies knowledge creation is a competency that likely supports efficient ongoing (and potential) transformational capabilities changes across the communicative-connectivities process domain. Specifically, AI-powered big data knowledge creation competencies can affect capabilities across the strategic marketplace (serving) decision-making domain (Bag et al., 2021). Further, an AI technologies knowledge creation change inclusion can then also affect this model's firm performance (competitiveness) outcomes. Hence, firm AI technologies knowledge creation is a likely required competence when delivering an ongoing AI-enhancing competitiveness positioning.

### ***Firm AI VRIO Innovation***

AI firm VRIO innovation captures AI predetermined valuable, rare, inimitable, and firm-specific input resourcing competence suite required to initiate the build of a competitive edge. (Barney et al., 2001; Lee, 2022). Such changeable AI focused VRIO input resourcing competences continually-refine, adapt over-time, and support sharper, better-aligned, more-efficient, digital operational capabilities systems, which in-turn can enhance an ongoing AI competitiveness position. From a resource-based view, strategic VRIO resources can enable AI-internal pathways towards a more sustainable competitiveness against relevant rivals, and in doing so, can leverage above-average profits, whilst also lessening competitive pressures (Agarwal et al., 2021).

### ***Firm AI Inputs and Initiatives Competencies Covariance***

Firm AI-driven VRIO innovation also engage firm AI IP capacities strategies, and firm AI knowledge-creating technologies techniques as competencies enlisted towards changing and/or transforming both internal processes and marketplace offerings. This also initiates dynamic AI technologies capabilities. Termed 'Edge AI' this initiates firm: competitive self-calibration, enhanced sensing, selective capture, and reputation (Agarwal et al., 2021), making machinery more-intelligent, smarter, and more self-aware. Edge AI links AI VRIO innovative ideas, internet of things (IoT) sensor devices, intelligent ML, and deep learning optimizations - delivering new capabilities performance levels to purposefully-enable, and dynamically-create, new firm and marketplace deliverables - like rapid prototyping, exploration of new device-combinations, and new feedback loop functionalities, that in-turn can simulate performance, assess functionalities, test personalization directions, increase conceptual precision, and interpret scalability (Agarwal et al., 2021). Thus the suite of AI inputs and initiatives competencies, supported by new Edge AI technologies and directions, bring an important, changeable dependency into firm competitiveness.

### ***AI and Firm Capabilities***

Firm AI deployment continues to accelerate in B2B and B2C marketplace environments - offering insights into consumer behaviors, marketplace insights, and streamlining of operational inefficiencies. AI competencies positively support fast AI capabilities actioning, and these can collectively contribute towards delivering rapid firm competitiveness (performance) outcomes (Mikalef et al., 2023). Furthermore, firm AI capabilities can offer higher informative AI-related effects, and can quicken firm AI-related quality decisions (Wamba-Taguimdje et al., 2020). Firm actioned operations collectively contribute towards the net capabilities available to the firm. Continuing across Figure 1, and considering a new firm from an AI incorporation perspective, firm AI capabilities are operationally actioned to strategically formulate, and deliver, new alternative products/services saleable suite solutions. Multiple dynamic consumptive construct areas help the new firm strategically build its Edge AI into its ongoing operational components.

AI as the key to technological intelligence advancements that achieve operational transformations capabilities (Dhamija & Bag, 2020). Their bibliometric analysis (2018-19) of English articles/documents finds six AI clusters emerge. AI first links to optimizations across a sector. Second AI links to firm research and advantageous automation against other sectors. Third AI supported operational performance and ML improve automated processes. Fourth AI brings an ongoing (sustainable)

interconnected supply chain - offering deep-thought development solutions. Fifth AI via technologies adoption, enhances ongoing (sustainable) developments, and sixth AI via IoT and reverse logistics feedback contributes towards economic, social and environmental sustainability outcomes. Broadly, AI exerts multiple network effects, across multiple firm operational capabilities areas including: values deliverance, risks mitigation, communicative connectivities and marketplace serving, and these targeted capabilities likely add towards building an ongoing AI-enhancing competitiveness positioning.

The AI values deliverance construct ensures as the operational area builds its quality, optimal performance product profitably. The AI risks mitigation construct involves the capture, assessment and solution across the competencies and capabilities network. The AI communicative connectivities ensures the consumer and the marketplace are transactionally-focused towards meeting or exceeding expectations. The AI marketplace serving construct ensures the logistics of best serving consumer and the marketplace are conducted in real-time to build consumer and marketplace confidence in the firm and its products. These firm actions collectively pursue the movement of unique ideas and initiatives towards providing a new, *ongoing AI-enhancing competitiveness* positioning against its rivals.

#### ***Firm AI Values Deliverance***

Firm AI value deliverance is the AI capabilities suite required to strategically build the net operational system that is in-demand and that can generate profit. Firm value deliverance systems typically lower costs (less inventory), reduce waste, and optimize the supply chain, (Nollet & Beaulieu, 2003). They bring further value adds across manufacturing (Khorasani et al., 2020), digitize products/services (Pirola et al., 2020), gauge resourcing changes, lift qualities, optimize performance, and grow profitable investments (Lahti et al., 2018). These measures blend across three different value deliverance constructs – qualities, performance, and economic worth. This complex firm AI values deliverance system has multi, sequenced networked components across qualities, performance and productive calibrations, and net economic worth. For example, Hamilton & Tee (2018)) see GitHub's open source digital value deliverance as a stage-wise data mining system combining qualities, performance, and economic worth capabilities with marketplace servicing, and workforce satisfying behavioral considerations. Ramanujam, (2020) also shows the value linkage between qualities, performance and economic worth in delivering a sustainable competitive business positioning.

#### ***Firm AI Risks Mitigation***

Firm AI risks mitigation is the AI capabilities suite required to strategically build risks minimized net operational components across all actioned operations. This complex system also has networked components capturing aspects of values, risks and communications. For example, Rana et al. (2022) adopt a resource-based and dynamic capability and contingency theory view and study the negative effects of AI business analytics components (including poor governance, poor data qualities, and poor workforce IP training) on delivering reduced operational efficiencies and negative economic worth plus delivering increased perceived risks, whilst also raising workforce dissatisfaction. These negatives network and likely result in a significant disadvantageous competitiveness positioning. The risk-competitiveness linkage further clarifies where AI risk mitigation capabilities decline, AI risks rise, and the AI-enhancing competitiveness positioning likely declines.

#### ***Firm AI Communication Connectivities***

Firm AI communication connectivities is the AI capabilities suite required to dynamically and strategically connect with the end-users in the marketplace across the interactive transaction medium employed. This complex system also has networked components capturing aspects of values, risks and communications. AI knowledge management as a process of acquiring, using, transferring, developing and storing digital data in a transparent, accessible, communications form that builds connectivities across business processes (Iaia et al., 2023). AI as combining with values deliverance (qualities and operational performance components) to AI support firm-consumer engagements in B2B environments (Chatterjee et al., 2021). The resultant performance-related outcomes significantly support an AI-enhancing competitiveness positioning.

#### ***Firm AI Marketplace Serving***

Firm AI marketplace serving represents the AI capabilities suite required to strategically build the net operational components that deliver service requirements into the marketplace. This complex system has networked components capturing aspects of values, risks and communications. Conceptually modeling AI and analytics capabilities as positively adding into marketplace sensing, seizing and reconfiguration capabilities components, and then towards improving an AI-enhancing competitiveness positioning (Hossain et al., 2022).

#### ***Firm AI-Enhancing Competitiveness***

AI competencies and AI capabilities collectively deliver an ongoing dynamic firm AI competitiveness (performance) positioning outcome (Mikalef et al., 2023). AI-at-the-Edge, or Edge AI approach, adds competitive self-calibration, enhanced sensing, selective capture, and digital reputation capabilities into the firm's AI competitiveness positioning (Agarwal et al., 2021). AI-powered big data knowledge creation significantly develops strategic marketplace decision making, and likely enhances the firm performance outcomes enhancing competitiveness – measured as a coalesced delivery of: customer retention, sales increases, higher profits, greater ROI, new markets capture, faster product/service introductions, faster new products acceptances, and greater market share (Bag et al., 2021).



## DISCUSSION

### AI Deliverance Framework

To date, the AI deliverance framework as shown in figure 2 remains conceptual although some researchers claim a firm can also achieve the same result across the same general construct system. However by including AI additive components these can reside across the entire suite of constructs – sometimes as Edge AI inclusions. Alternatively, they can exclusively (or in part) enter the ongoing competitiveness system as external suite of AI moderators. This alternative moderator inclusion pathway option can also be tested as impacting across the pathways of figure 2's AI deliverance framework. In this inclusion option, the firm's competencies to capabilities to competitiveness system, accepts an external injection of likely useful AI additive components, and likely incorporates these in pursuit of further expanding its AI-enhancing competitiveness. Collectively, these measures spread over much of the competencies and capabilities of Figure 2 - giving father support to the competencies to capabilities to competitiveness AI deliverance framework proposed below.

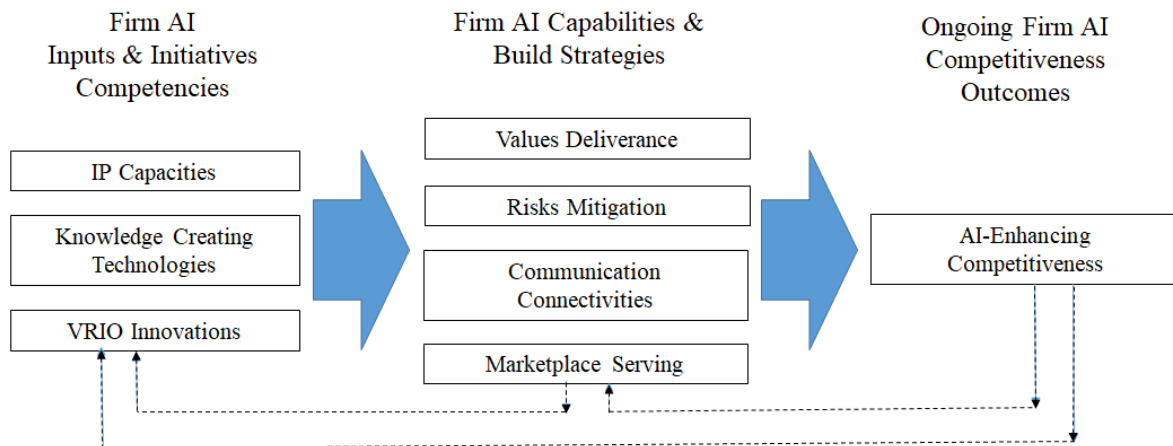

Figure 2: AI deliverance framework with AI feedback loops.

### Implications of Research

#### Theoretical Implications

This study draws on data capture across many firm business measurement domains. Competencies-related theories include: resource based (Barney, 1991), competencies based (Prahalad & Hamel, 2009), dynamic capabilities (Teece et al., 1997), and dynamic competition (Petit & Teece, 2021). It adds expectations, motivation, consumption, and user-gratification theories, into its capabilities relationships. As the firm is consumer and marketplace end-user focused when investigating its AI inclusions, alignment to marketing theories is expected. The European Journal of Marketing 50 year collation of fifty widely-used key words is theory linked by Martínez-López et al., (2018). Relevant theories to this AI deliverance framework study include: consumer behavior, marketing, strategy, customer satisfaction, relational marketing, market orientation, trust, retailing, consumers, equity, loyalty, identity, brand image, stakeholder analysis, buyer-seller relationships, innovation, marketing theory, performance, marketing communications, brand image, research, market segmentation, pricing, competitive strategy, financial service, international marketing, consumption, services, empowerment, culture, and customer orientation (Martínez-López et al., 2018, Table X. Thus this study has a vast array of theoretical support.

#### Practical Implications

This study offers a new firm construct measurement approach towards building AI-enhancing competitiveness. To date this is a first literature study formally linking firm AI competencies to AI capabilities, and these then forming a precursor network suite focused towards delivering firm AI-enhancing competitiveness.

### Future Research

#### Measurement Aspects

This study recognizes that when considering firm AI inputs and initiatives three major competencies construct areas are consistently required. First firm AI IP capacities retain a tangible (or physical) firm-possessed AI point-of-difference. Second, firm AI knowledge creating technologies bring a digital intangible dimension to the firm's AI. Third, Firm sourced and developed VRIO innovations bring newly discovered futures-focused tangible and intangible resourcing dimensions into the firm's competencies. These three competencies are interrelated and so likely covary as predicted above. Hence these independent competencies are proposed as a general prerequisite AI suite when updating and reframing the firm. It is likely that the interdependence between these three competencies suites varies depending on such things as: the country, the industry, the firm, the leadership and its' strategic approach, the firm's technical competence, the workforce, the firm's specific products/services, the risks involved, the firm-allocated AI investment level, the consumer and the marketplace. Research and measurement into the items making up each construct is now required.

The firm AI capabilities and build strategies constructs represent four interrelated systems (values deliverance, risks, connectivities and serving). Each is dependent on the available competencies mix. Research regarding measurement and understanding is required as to how these embedded systems operate and network towards delivering AI-enhancing competitiveness.

The inclusion of AI can be achieved by several pathways and each can exert differing AI-enhancing competitiveness outcomes. For example (1) AI can be selectively step-by-step added to a chosen construct (or related constructs), or (2) AI can be added across the full network of constructs, or (3) AI can be added as a moderator to select relational pathways, or (4) AI can be added at the edge (Edge AI) of the existing system. The optimal AI inclusion approach remains unclear and so is an area for further research.

### **Theoretical Aspects**

#### **Theory of AI Adoption**

At firm/business level, or at the industry level, a certain level of input AI competencies need to be present before enacted firm AI capabilities can deliver significant operational enhancements. This firm AI approach encompasses 'Diffusion of Innovation theory,' along with a 'Resource Based View' approach. The 'Theory of Adoption' adds choice (accept/reject) of a chosen idea or innovation. An 'AI Intelligence theory' adds that developing technologies systems can execute tasks (visual, speech, decisions, language, translations, and the like) in real-time and in preference to a firm's workforce. Thus a 'Theory of AI Adoption' can be stage-wise proposed as:

*'sourcing/examining, selecting/exploring, accepting/rejecting, and adopting/exploiting, a particular additive mix of latest AI innovative and useful components into the firm's (or the industry's) business solution.'*

#### **Theory of AI-Enhancing Competitiveness**

This study proposes the inclusion of smart AI solutions into the firm (or into an industry) brings a new knowledge approach that likely changes firm competitiveness. A theory of 'AI-Enhancing Competitiveness' is defined as:

*'a knowledge-driven competencies and capabilities collation, engaging innovative digital deep-learning, along with robust stage-wise interpretations that ultimately coalesce and deliver a beneficial change to the existing competitiveness position.'*

### **Management Aspects**

Management can investigate how Figure 2's feedback loops can best measure to facilitate useful real-time change solutions. The negatives to AI inclusions can also be located and eliminated. As changes are implemented by management the relative strengths of pathways within Figure 2's model may require further optimization or adjustments. The way AI is included need to be determined for the firm, the business and the industry under consideration.

## **CONCLUSION**

This study concludes AI competencies and AI capabilities together model towards delivering a dynamic AI-enhancing competitiveness position. It proposes AI-enhancing competitiveness as a stage-wise, developmental, intelligent and changeable construct - arising from firm-relevant AI inclusions bringing positive, innovative changes to the existing complex systems of interrelated competencies and capabilities, and their network coalescence towards an AI-enhancing competitiveness positioning.

This study expands knowledge regarding AI and firm competitiveness. Its literature research frames the Figure 2 AI deliverance framework, and highlights different ways AI can be included in the firm's competitiveness strategies. The feedback loops of Figure 2 allow selective, preferential, maximum-impact, near real-time changes to be tested as rapid improvement mechanisms to the existing AI-deliverance system. The research agenda asks for executive firm-feedback regarding adoption of AI competencies to action AI related capabilities, and to help drive firm AI-enhances competitiveness..

## **REFERENCES**

- Abou-Foul, M., Ruiz-Alba, J. L., & López-Tenorio, P. J. (2023). The impact of artificial intelligence capabilities on servitization: The moderating role of absorptive capacity-A dynamic capabilities perspective. *Journal of Business Research*, 157, 113609, 1-16.
- Agarwal, G. K., Magnusson, M., & Johanson, A. (2021). Edge AI driven technology advancements paving way towards new capabilities. *International Journal of Innovation and Technology Management*, 18(01), 2040005, 1-25.
- Alkhatib, A. W., & Valeri, M. (2022). Can intellectual capital promote the competitive advantage? Service innovation and big data analytics capabilities in a moderated mediation model. *European Journal of Innovation Management*. June, 1-27.
- Alsheibani, S., Cheung, Y., & Messom, C. (2018). Artificial Intelligence Adoption: AI-readiness at Firm-Level. *PACIS*, 4, 231-245.
- AlSheibani, S., Messom, C., & Cheung, Y. (2020). Re-thinking the competitive landscape of artificial intelligence. In *Proceedings of the 53rd Hawaii International Conference on System Sciences* (pp. 5861-5870), Hawaii.
- Bag, S., Gupta, S., Kumar, A., & Sivarajah, U. (2021). An integrated artificial intelligence framework for knowledge creation and B2B marketing rational decision making for improving firm performance. *Industrial Marketing Management*, 92, 178-189.
- Barney, J. B. (2007). *Gaining and sustaining competitive advantage* (3rd Ed). Upper Saddle River, NJ: Prentice Hall.

- Barney, J., Wright, M., & Ketchen Jr, D. J. (2001). The resource-based view of the firm: Ten years after 1991. *Journal of Management*, 27(6), 625-641.
- Chatterjee, S., Rana, N. P., Tamilmani, K., & Sharma, A. (2021). The effect of AI-based CRM on organization performance and competitive advantage: An empirical analysis in the B2B context. *Industrial Marketing Management*, 97, 205-219.
- Collins, C., Dennehy, D., Conboy, K., & Mikalef, P. (2021). Artificial intelligence in information systems research: A systematic literature review and research agenda. *International Journal of Information Management*, 60, 102383, 1-17.
- Davenport, T. H., Guha, A., & Grewal, D. (2021). How to design an AI marketing strategy. *Harvard Business Review*, 99(4), 42-47.
- Debnath, R., Datta, B., & Mukhopadhyay, S. (2016). Customer relationship management theory and research in the new millennium: Directions for future research. *Journal of Relationship Marketing*, 15(4), 299-325.
- Dhamija, P., & Bag, S. (2020). Role of artificial intelligence in operations environment: a review and bibliometric analysis. *The TQM Journal*, 32(4), 869-896.
- Hamilton, J. R. & Tee, S. (2018). Big data values deliverance: OSS mode. In *Proceedings International Conference on Electronic Business, Volume 18* (pp. 154-162). ICEB, Guilin, China, December 2-6.
- Hossain, M. A., Agnihotri, R., Rushan, M. R. I., Rahman, M. S., & Sumi, S. F. (2022). Marketing analytics capability, artificial intelligence adoption, and firms' competitive advantage: evidence from the manufacturing industry. *Industrial Marketing Management*, 106, 240-255.
- Iaia, L., Nespoli, C., Vicentini, F., Pironti, M., & Genovino, C. (2023). Supporting the implementation of AI in business communication: the role of knowledge management. *Journal of Knowledge Management*, (ahead-of-print).1-11. DOI 10.1108/JKM-12-2022-0944.
- Kemp, A. (2023). Competitive Advantages through Artificial Intelligence: Toward a Theory of Situated AI. *Academy of Management Review*.
- Khorasani, S. T., Cross, J., & Maghazei, O. (2020). Lean supply chain management in healthcare: a systematic review and meta-study. *International Journal of Lean Six Sigma*. 11(1), 1-34.
- Krakowski, S., Luger, J., & Raisch, S. (2023). Artificial intelligence and the changing sources of competitive advantage. *Strategic Management Journal*, 44(6), 1425-1452.
- Lahti, T., Wincent, J., & Parida, V. (2018). A definition and theoretical review of the circular economy, value creation, and sustainable business models: where are we now and where should research move in the future? *Sustainability*, 10(8), 2799, 1-19.
- Lee, K. K. (2022). A Study on 7-Eleven's Core Competencies: Focusing on the VRIO Model. *International Journal of Advanced Culture Technology*, 10(1), 67-74.
- Makarius, E. E., Mukherjee, D., Fox, J. D., & Fox, A. K. (2020). Rising with the machines: A sociotechnical framework for bringing artificial intelligence into the organization. *Journal of Business Research*, 120, 262-273.
- Martínez-López, F. J., Merigó, J. M., Valenzuela-Fernández, L., & Nicolás, C. (2018). Fifty years of the European Journal of Marketing: a bibliometric analysis. *European Journal of Marketing*, 52(1/2), 439-468.
- Mikalef, P., Islam, N., Parida, V., Singh, H., & Altwaijry, N. (2023). Artificial intelligence (AI) competencies for organizational performance: A B2B marketing capabilities perspective. *Journal of Business Research*, 164, 113998, 1-11.
- Nollet, J., & Beaulieu, M. (2003). The development of group purchasing: an empirical study in the healthcare sector. *Journal of Purchasing and Supply Management*, 9(1), 3-10.
- Petit, N., & Teece, D. J. (2021). Innovating big tech firms and competition policy: favoring dynamic over static competition. *Industrial and Corporate Change*, 30(5), 1168-1198.
- Pirola, F., Boucher, X., Wiesner, S., & Pezzotta, G. (2020). Digital technologies in product-service systems: a literature review and a research agenda. *Computers in Industry*, 123, 103301, 1-19.
- Prahalad, C. K. (1993). The role of core competencies in the corporation. *Research Technology Management*, 36(6), 40-47.
- Prahalad, C. K., & Hamel, G. (2009). The core competence of the corporation. In Michael H. Zack, (Ed.), *Knowledge and Strategy* (pp. 41-59). London, UK: Routledge.
- Ramanujam, R. (2020). *Delivering competitiveness across management consulting firm and client firm boundaries* (Doctoral dissertation, James Cook University, Cairns, Australia), 1-121.
- Rana, N. P., Chatterjee, S., Dwivedi, Y. K., & Akter, S. (2022). Understanding the dark side of artificial intelligence (AI) integrated business analytics: assessing firm's operational inefficiency and competitiveness. *European Journal of Information Systems*, 31(3), 364-387.
- Rowland, M., Carroll, N., & Conboy, K. (2022). Examining the Adoption of Artificial Intelligence for Digital Transformation. In *Proceedings European Conference on Information Systems*, (pp. 1-14), Timișoara, Romania.
- Shankar, V. (2018). How artificial intelligence (AI) is reshaping retailing. *Journal of Retailing* 94 (4), 6-11.
- Singh, A. K., Verma, J., & Verma, R. (2020). Understanding the role of market-orientated IT competence and knowledge sharing mechanism in gaining competitive advantage. *Global Business Review*, 21(2), 418-435.
- Teece, D. J., Pisano, G., & Shuen, A. (1997). Dynamic capabilities and strategic management. *Strategic Management Journal*, 18(7), 509-533.
- Townson, S. (2021). 3 areas where AI will boost your competitive advantage. *Harvard Business Review*, Dec.
- Varmavuo, E. (2020). Factors affecting the success of AI campaigns in marketing: data perspective. *Jyväskylä University, Master's Thesis*, 1-61.

- Vishnoi, S. K., Bagga, T., Sharma, A., & Wani, S. N. (2018). Artificial intelligence enabled marketing solutions. A review. *Indian Journal of Economics & Business*, 17(4), 167-177.
- Wamba-Taguimdje, S. L., Fosso Wamba, S., Kala Kamdjoug, J. R., & Tchatchouang Wanko, C. E. (2020). Influence of artificial intelligence (AI) on firm performance: the business value of AI-based transformation projects. *Business Process Management Journal*, 26(7), 1893-1924.
- Wang, J., Omar, A. H., Alotaibi, F. M., Daradkeh, Y. I., & Althubiti, S. A. (2022). Business intelligence ability to enhance organizational performance and performance evaluation capabilities by improving data mining systems for competitive advantage. *Information Processing & Management*, 59(6), 103075, 1-14.
- Zhang, B., Zhu, J., & Su, H. (2023). Toward the third generation artificial intelligence. *Science China Information Sciences*, 66(2), 121101, 1-19.

## An Empirical Study of Impulse Purchase in E-commerce Live Streaming from The E-commerce Marketing Mix Perspective

Fuyume Sai <sup>1,\*</sup>  
Guannan Su <sup>2</sup>

\*Corresponding author

<sup>1</sup> Daito Bunka University, Tokyo, Japan, Professor, fuyume-sai@ic.daito.ac.jp

<sup>2</sup> Daito Bunka University, Tokyo, Japan, Master Student, s22261002@st.daito.ac.jp

### ABSTRACT

E-commerce live streaming has undergone rapid development in recent years. Technically, it is the combination of traditional e-commerce and live streaming, allowing salespeople to conduct sales operations and interact with and serve customers in real-time to improve their shopping experience. This study uses the e-commerce marketing mix (*product, promotion, place, people, process, physical evidence*) to conceptualize its influences on the shopping experience (*product involvement* and *flow experience*) and the outcome behavior (*impulse buying*). The research model is measured and evaluated by using the PLS-SEM method based on 248 valid questionnaire samples from China. The findings show that *place* has the most effect on *product involvement*, followed by *product, people, process*, and on the *flow experience, process* is most effective, followed by *physical evidence, place*, and *people*. In terms of the role of the shopping experience, *product involvement* has a fully mediating effect between *product* and *impulse buying*, and *flow experience* mediates the effect partially between three relationships: *place, process*, and *physical evidence* to *impulse buying*. Different from prior studies, we adapted the e-commerce marketing mix to provide empirical evidence for research on impulse purchases via e-commerce live streaming.

**Keywords:** E-commerce live streaming, Impulse buying, E-commerce marketing mix, Involvement, Flow experience, PLS-SEM.

### INTRODUCTION

Also known as the 4Ps and/or 7Ps theory, the original marketing mix proposes four strategic elements for internal management to achieve business goals, named by McCarthy (1964) as product, price, promotion, and place. 7Ps theory proposed by Booms and Bitner (1981) extends strategic focuses from product-centered to service-oriented management. In addition to the 4Ps, three service elements are introduced: people, process, and physical evidence. The three "service Ps" posit that management cannot ignore the needs of customers. As defined by Kotler and Armstrong (1989), marketing mix is "the set of controllable marketing variables that the firm blends to produce the response of wants in the target market." In achieving marketing goals, the combination of 4Ps focuses on the promotion of products, while 7Ps on persuading customers. 4Ps pay more attention to the push strategy, whereas 7Ps adopt the pull strategy to approach more prospective customers and consumers and to identify their needs and perceptions.

Marketing mix elements are means to an end, they pave the way for marketing managers to achieve organizational goals and objectives through proper planning. Regarding information services and trade of online stores, Pogorelova et al. (2016) formulated a 7Ps marketing mix for e-commerce and discussed the significant influence of consumers on the content change of 7Ps. By using the e-commerce marketing mix model, Ghiffarin et al. (2019) analyzed the performance of each "P" on e-commerce utilization from the small and medium enterprises of batik. Concisely in the context of e-commerce, the 7Ps can be referred to as follows: *Product* is an offer in form of texts, graphs, short videos or others. Those forms capture consumers' perception of the characteristics and features of the product and information relevant to product updates; *Price* provides a comparative analysis of price and display of price fluctuations; *Promotion* activities encourage customers to engage in the selling process. Customer reviews and sales promotions such as discounts, coupons, premiums, and so on can incite customers to take targeted actions (approval, registration, download, purchase, recommendation); *Place* of sale should maximize the availability of sales channels for both buyers and sellers; As replaced by technology, *People* is "invisible" during personal selling and customer service, which are implemented in an interface e.g., e-shore; *Process* refers to the standardized operating procedures run by human-computer interactions; *Physical evidence* includes a website, pages in social network, and/or mobile applications.

As a conceptual framework, prior studies have applied the 7Ps marketing mix in various fields such as information service (Liu, 2022), education (Ivy, 2008) and others. Recently, the 7Ps application has been conducted in e-commerce live streaming research. E-commerce live streaming (ECL) is the fastest-growing sales technology tool integrated with live streaming and e-commerce. It offers explosive potential for conducting sales operations and interacting with and serving customers, which in turn gets customers more involved and immersed in ECL's selling (Bu et al., 2023; Arora et al., 2021). Ho et al.(2022) applied the traditional 7Ps concepts to explore the relationship between the 7Ps marketing mix and purchase intention in live streaming platforms. The results revealed that promotion, place, and physical evidence have positive effects on customers' watching and purchase intention. However, to date, no other study that investigated the influence of the 7Ps combination on consumers'

impulse buying. Therefore, the present research aims to fill this research gap and provide an empirical study of impulse purchase in ECL. Different from prior studies using the traditional 7Ps concepts, we take the e-commerce marketing mix as stated above and adapt it for ECL from the consumers' point of view.

Impulse purchase is a common phenomenon in online shopping (Liu et al., 2013). Much empirical research deals with it as a sudden, spontaneous, and immediate purchase with no specific buying intentions, and an urge to buy without much consideration of the buying consequences (Rook, 1987). Chan et al., (2017) conducted a literature analysis on online impulse buying research, proposing that impulse purchase can be an outcome of cognitive and/or affective reactions triggered by the stimuli from website, marketing, situational, or personal characteristics. In line with the prior studies, we focus on impulse purchase in ECL by taking the e-commerce marketing mix as a means to induce consumers' cognitive and affective shopping experience which in turn leads to impulse buying. For doing so, the remainder of this paper is organized as follows. First, we review the theoretical background and then develop a research model and hypotheses. Next, we present the results of model measurement and hypothesis testing by using empirical data. And we conclude by discussing the findings in the end.

## **THEORETICAL BACKGROUND AND HYPOTHESES**

### **Involvement**

Involvement is one of the most important variables in consumers' purchase behavior research (Martin, 1998; Evrard & Aurier, 1996). To date, much research has proposed several definitions, but there is no universal version for the variable. Generally, involvement is conceptualized as an internal cognitive state of the consumer engendered by certain marketing stimuli or tasks or interests in a certain goal or event (Zaichkowsky, 1985; Celsi & Olson, 1988). On the other hand, it is also referred to as a motivational state concerning the relationship between a product and the individual's values built on the product's practicality, symbolic meaning, and hedonic value (Mittal & Lee, 1989). The level of involvement is fundamentally the embodiment of the results of personal internal factors subjected to different types of stimuli and situations and leads to differences in consumers' information processing methods and purchase decision-making processes. It urges consumers to show a series of information processing strategies such as information search and information processing through perception, interest, or motivation evoked by specific stimuli or situations (Mittal, 1989). In addition, the involvement construct has been divided into cognitive and affective involvement (Zaichkowsky, 1994). Cognitive involvement focuses on the functional and utilitarian aspects of the product; affective involvement is caused by value expressions or emotional motivations. Thus, cognitive involvement encompasses reasoning and factual information, whereas affective involvement is associated with emotion and mood (Zaichkowsky, 1994). Overall, involvement includes an assessment of the importance of the stimulus/situations, which in turn produces a certain behavior.

Previous studies have investigated *Involvement* in various cognitive processes. For example, consumers who are involved with a product category tend to devote more attention to relevant marketing stimuli, focus their attention on product-related information, and engage in more elaboration of the product information during comprehension of the information (Celsi & Olson, 1988; Drossos, 2014). In studying online consumer behavior, Koufaris (2002) concluded that the richer the consumer's knowledge about the product, the more impulse buying and revisiting intention to be produced. Chan et al., (2017) indicated that product involvement (cognitive and affective) is one of the main influencing factors of online impulse buying. Gong et al. (2023) examined that product involvement has a positive effect on impulse buying behavior. Therefore, in this study, we propose that involvement (product involvement) has a positive impact on impulse buying.

### **Flow Experience**

Flow theory originated from Csikszentmihalyi's research on games. He defines flow as an overall experience that people feel when they fully engage in an activity. It is believed that flow is an important antecedence of why people continue to participate in a certain behavior (Csikszentmihalyi, 1975). During the flow state, people appear to be drawn in, the focus of consciousness is narrowed down, and the perceptions and thoughts not related to the target are filtered out and/or ignored. That is, when people are immersed in what they are doing, they lose self-awareness, focusing only on the specific goal and/or activity, responding to explicit feedback and feeling a sense of control through manipulation of the environment (Csikszentmihalyi, 1990). The main constructive indicators examined in prior studies for the variable of flow are perceived enjoyment, perceived utility, perceived control, attentional concentration, and time distortion (Koufaris, 2002; Hoffman & Novak, 1996).

Flow experience has been applied in an examination of online marketing activities (Hoffman & Novak, 1996), online shopping behavior and human-computer interactions (Donna et al., 2018). Recent studies have adopted flow as a mediator to investigate the influences of marketing stimuli on impulse purchases in the context of ECL. In studying the relationship between atmosphere cue, flow experience and impulse buying in ECL, Gong et al. (2019) examined the impact of flow experience ( $\beta=0.742$ ,  $p < .001$ ) on impulse buying intention. Feng et al. (2020) combined trust and flow experience to investigate the influence of social presence on impulse buying. The study showed that flow experience has a positive impact ( $\beta = 0.300$ ,  $p < .001$ ) on impulse purchases via live streaming. Thereby, in this study, we assume that flow experience has a positive effect on impulse buying via live streaming.

### The E-Commerce Marketing Mix as a Means

In addition to the functions of traditional e-commerce (e.g., information display, ordering), ECL visualizes salesperson (streamer: *People*) and e-store (livestream room: *Physical evidence*) and sells products with real-time interpersonal interactions (*Process*). In livestream room streamer provides more vivid and comprehensive product information (*Product*) and answers customer questions or concerns (*Process*), allowing customers to better understand product features (including price and/or price comparison), functions, and specifications in real-time and among others (e.g., how to use), increasing consumer awareness and interest in products (*Product*) and desire to buy. Consumer promotion in the livestream room can be multiple options such as limited-time or limited-quantity discounts, coupons, rebates, gifts, or other rewards (*Promotion*) to customers who buy via live product demonstration, which encourages consumer's impulse buying. As ECL combines live streaming with e-commerce, it inherits the functionality of e-commerce and can provide availability of sales channels (*Place*) for both buyers and sellers. Table 1 shows the elements of the e-commerce marketing mix in this study.

Table 1: The marketing mix elements for e-commerce live streaming

Element	Definition
Product	Product[-centered information] presented by streamer
Promotion	Consumer promotion during live streaming e.g., limited-time/quantity discounts, rebates, gifts
Place	Availability of ECL for shopping e.g., method of purchase, information on shipping, logistics
People	Streamer's attractiveness itself
Process	Interactivity [interactions in live streaming] e.g., streamer-customer-viewers, customer participation
Physical evidence	Interface design of livestream room e.g., structure, color, visual display

Source: Adapted from Pogorelova et al. (2016) & Ghiffarin et al. (2019).

Streamer plays an important role in ECL. In addition to the attractiveness of the streamer itself (*People*) which can engender perceived pleasure and induce impulsive intention to buy, several studies have explored whether interactions between streamers and customers (*Process*) during live streaming affect consumers' purchase behavior. For example, Wei et al. (2022) investigated the relationship between the characteristics of the streamer and impulse purchases, showing that the streamer's attractiveness and interactivity have a positive impact on impulse buying intention mediated by flow experience. The study conducted by Liu et al. (2020) suggested that streamer's professionalism can increase consumers' awareness of products or services, and thus affect consumer purchase behavior. Li (2020) pointed out that real-time interactions between streamers and consumers, and opinions exchanged between consumers during live streaming can affect impulse buying behavior positively. As evidenced by Yin & Wang (2022), the professionalism of the streamer can allow consumers to understand the features and functions of the product accurately and comprehensively, thus, generating positive emotions and triggering consumers' impulse buying behavior.

Compared with the shopping environment of traditional e-commerce which delivers information through characters, pictures, and videos, ECL can create a better shopping experience. In the livestream room, customers can see the products and the product-related information presented by a streamer (*Product*) promptly, asking the streamer to introduce the product in more detail, forward comments to consult questions about products, communicate with other consumers, and devote more attention to the product. Moreover, convenient ways of shopping and effective service after ordering (*Place*) relevant to e.g., shipping and logistics are indispensable. These shopping experience can increase consumers' positive emotions and get them involved effectively (Sun et al., 2019) which cause impulse buying. On the other hand, the atmosphere cue engendered in the livestream room makes customers experience flow. For example, Gong et al. (2019) measured atmosphere cue from perspectives of information, ease of use, and interface design of the ECL platform (*Physical evidence*), exploring its relationship with impulse purchase via live streaming based on the mediation of flow experience. The results revealed that flow has a partial mediating effect between atmosphere cues and impulsive buying intention.

In ECL, streamers can direct consumer promotions (*Promotion*) toward customers and viewers who are involved in the livestream room to urge them to buy or enhance their product involvement. In a study investigating impulse buying led by emotional experience, Sun et al. (2022) reported that price discounts, streamer's characteristics and interactions in livestream room are focal factors enhancing perceived pleasure and perceived arousal to induce consumer impulse purchase. In an analysis of impulsive purchase intention of apparel, Xu et al. (2021) also found that price discounts, and other constructs (live interaction, live entertainment, opinion leaders, visibility, merchant services, and value-added content) have a significant positive influence on impulse buying by mediation of perceived pleasure and perceived arousal. In an experimental study that set out to test the role of prospective emotion in the formation mechanism of impulse buying intention in ECL, Yue & Lu (2021) showed that limited-time and limited-quantity discounts can affect consumers' impulse purchase intention via ECL, and future-oriented emotion plays a mediating role. Following the prior research, therefore in this study, we hypothesize that each element of the e-commerce marketing mix (*Product, Promotion, Place, People, Process, Physical evidence*) affects product involvement and flow experience positively.

### RESEARCH MODEL

Figure 1 depicts the research model and shows the hypotheses for this study. As stated above, each element of the e-commerce marketing mix affects product involvement and flow experience, which in turn causes consumers' impulse purchases via ECL. As regards *Price* in the e-commerce marketing mix, since *Price* as a feature of product-related information is presented by



streamers during live streaming, we integrate the *Price* with *Product* from consumers' point of view. Thus, the research model is comprised of 9 constructs in total. The label *Involvement* denotes product involvement.

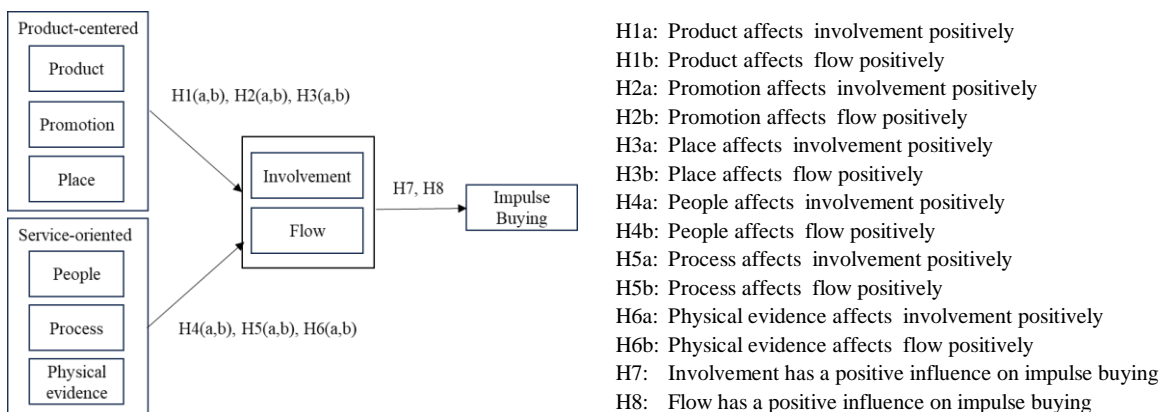

Figure 1: Research model and hypotheses

**INSTRUMENT DEVELOPMENT**

The scale and items for all constructs used in this study were taken from the previous literature, with minor modifications, as needed to customize them to the context of this study. Collectively, it becomes 37 items for all variables, that is, three items for *Product* (Chang et al., 2020; Floh et al., 2013), three items for *Promotion* (Chan, 1997), three items for *Place* (Wu et al., 2016), five items for *People* (Wei et al., 2022), nine items for *Process* (Ming, 2021), three items for *Physical evidence* (Floh et al., 2013), three items for product *Involvement* (Faisal et al., 2021; Gong et al., 2023), four items for *Flow* (Marsh & Jackson, 1996; Hoffman & Novak, 2009) and four items for *Impulse buying* (Rook & Fisher, 1995). All these items are measured by using a 5-point Likert scale ranging from 1 (strongly disagree) to 5 (strongly agree). Table 2 shows the items of each construct.

Table 2: The items of the constructs

Construct	Code	Item Wording
Product (PROD)	prod_1	In live streaming, the streamer carefully presents the products, services and information that consumers want.
	prod_2	In live streaming, the streamer recommends products and services based on consumers' requirements.
	prod_3	In live streaming, the streamer provides the latest product information in a timely manner.
Promotion (PROM)	prom_1	In live streaming, I am easily tempted by discounts promotion.
	prom_2	In live streaming, the promotion makes me want to buy.
	prom_3	In live streaming, I look or pick out items that are on sales promotion carefully.
Place (PLAC)	plac_1	The convenient and fast ordering method of the livestreaming platform make me want to buy more.
	plac_2	The interface of the livestreaming platform is friendly and easy to use.
	plac_3	The customer service response from the livestreaming platform is efficient.
People (PEOP)	peop_1	The streamer makes me feel kind.
	peop_2	The streamer catches me attention.
	peop_3	The streamer makes me happy.
	peop_4	I approve of the way of life and entertainment demonstrated by the streamer.
	peop_5	I think the streamer is funny and can arouse my interest in shopping.
Process (PROC)	proc_1	In live streaming, the streamer responds to consumers' questions or concerns in a timely manner.
	proc_2	In live streaming, the content presented by the streamer allows consumers to participate effectively.
	proc_3	In live streaming, the content presented by the streamer arouses consumers' interests.
	proc_4	In live streaming, I sometimes comment on the products and share how I feel about them with other viewers.
	proc_5	In live streaming, I sometimes discuss product information and usage experience with other viewers.
	proc_6	In live streaming, I sometimes post some words for entertainment.
	proc_7	In live streaming, other viewers sometimes discuss some entertainment topics with me.
	proc_8	In live streaming, other viewers sometimes share information about the products and how they feel about them.
	proc_9	In live streaming, other viewers sometimes send some words for entertainment.
Physical evidence (PHYC)	phyc_1	The colors used in the livestreaming room are attractive.
	phyc_2	The livestreaming room is visually pleasing to me.
	phyc_3	The layout of the livestreaming room is attractive.
Involvement (INVO)	invo_1	In live streaming, I think the products recommended by the streamer are what I need.
	invo_2	In live streaming, I think the products recommended by the streamer are valuable to me.
	invo_3	In live streaming, I think the products recommended by the streamer are relevant to me.
Flow (FLOW)	flow_1	In live streaming, I often experience pleasure.
	flow_2	In live streaming, the pleasure I experience keeps me watching.
	flow_3	In live streaming, I feel time going so fast.
	flow_4	In live streaming, I am immersed in it and don't pay much attention to other things.
Impulse buying (IMPU)	impu_1	In live streaming, I bought items that I didn't plan to buy.
	impu_2	In live streaming, I bought a lot of items that I won't be using in the coming days.
	impu_3	In live streaming, I bought items without thinking much about them.
	impu_4	In live streaming, I am affected by emotions which make me shopping.

## RESEARCH METHOD

### Sampling and Data collection

The population selected to carry out this research were individuals residing in China who have experience in online shopping via live streaming. Data was collected in an anonymous online survey form from 23<sup>rd</sup> May 2023 to 30<sup>th</sup> May 2023. A total of 256 forms were obtained, whereof 8 forms were excluded due to incomplete responses with missing the questions or aberrant responses lacking justification. Consequently, 248 valid samples are remained and subsequently summarized. Table 3 displays the demographic statistics of respondents in detail.

Table3: Sample profiles (n = 248)

Profile	Category	Frequency	Percentage
Gender	Male	118	47.6
	Female	130	52.4
Age	<20	19	7.7
	21-30	86	34.7
	31-40	57	23.0
	41-50	51	20.6
	>50	35	14.1
Education	Diploma/Lower	36	14.5
	Below Graduate	68	27.4
	Graduate	94	37.9
	Post Graduate /Higher	50	20.2
Occupation	Student	38	15.3
	Company employee	108	43.5
	Self-employed	53	21.4
	Others	49	19.8
Controllable money (monthly, CNY*)	<1000	29	11.7
	1000-3000	45	18.1
	3000-5000	99	39.9
	<5000	75	30.2
Viewing time of livestream shopping	<5 hours	63	25.4
	6-10 hours	96	38.7
	11-15 hours	52	21.0
	>15 hours	37	14.9

\*CNY = Chinese yuan

## DATA ANALYSIS AND RESULTS

For the validation of the model, we used the method of partial least square (PLS) to ensure the reliability and validity of the measurement scales and the structural equation modeling (SEM) with PLS (PLS-SEM) for model and hypothesis testing. Compared with the covariance-based structural equation modeling, PLS-SEM is variance-based and suitable for causal-predictive analysis and theory building, for example, when the objective of the analysis is to predict and identify determinants of consumer behavior (Hair et al., 2012). In addition, it is capable of handling non-normally distributed data, and is less affected by small sample sizes (Henseler et al., 2014). Thus, in recent years, PLS-SEM has been widely used in social science disciplines (Hair et al., 2019). The present study applies R (ver.4.3.0) to run the PLS-SEM analysis and test the proposed hypotheses.

### Measurement Model

The goal of this step is to ensure the reliability and validity of construct measures. For each construct, indicator reliability (indicator loadings), internal consistency reliability (Cronbach's alpha coefficients ( $\alpha$ ) and composite reliability (CR)), convergent validity (average variance extracted (AVE)), and discriminant validity (heterotrait-monotrait ratio (HTMT)) are evaluated respectively by following the guideline of Hair et al. (2017). As can be seen in Table 4, all the indicator loadings are more than 0.707 meaning that more than 50% of each indicator's variance is explained by its construct. As regards internal consistency reliability, the data shows an adequate internal consistency reliability with  $\alpha$  ranging in [0.804, 0.920] and CR ranging in [0.884, 0.934]. Convergent validity for all indicators on each construct is evaluated by AVE values. The AVE values in Table 4 for all measures surpassed the recommended value of 0.5 (Hair et al., 2017). Discriminant validity is assessed by using HTMT proposed by Henseler et al. (2015) and calculated by running the bootstrapping routine (5000 samples). The HTMT value should be below 0.90 or 0.85 (Henseler et al., 2015). As shown in Table 5, the HTMT values of all the constructs in the model are lower than 0.85, thereby, discriminant validity across constructs in the model is supported.

Table 4: Evaluation of construct validity and reliability

Constructs	Code	Loadings	Mean	SD	Cronbach's alpha	rhoA	CR	AVE
Product (PROD)	PROD_1	0.915	3.498	1.309	0.857	0.869	0.913	0.777
	PROD_2	0.875	3.279	1.223				
	PROD_3	0.853	3.259	1.147				
Promotion (PROM)	PROM_1	0.882	3.401	1.238	0.833	0.841	0.899	0.749
	PROM_2	0.884	3.316	1.205				
	PROM_3	0.830	3.348	1.133				
Place (PLAC)	PLAC_1	0.883	3.377	1.165	0.804	0.819	0.884	0.718
	PLAC_2	0.85	3.194	1.184				
	PLAC_3	0.808	3.231	1.051				
People (PEOP)	PEOP_1	0.819	3.368	1.157	0.875	0.877	0.909	0.667
	PEOP_2	0.830	3.279	1.158				
	PEOP_3	0.801	3.146	1.138				
	PEOP_4	0.821	3.312	1.061				
	PEOP_5	0.813	3.340	1.114				
Process (PROC)	PROC_1	0.795	3.174	1.118	0.921	0.922	0.934	0.610
	PROC_2	0.796	3.227	1.139				
	PROC_3	0.773	3.130	1.122				
	PROC_4	0.809	3.247	1.155				
	PROC_5	0.744	3.336	1.095				
	PROC_6	0.774	3.267	1.098				
	PROC_7	0.788	3.243	1.125				
	PROC_8	0.794	3.117	1.062				
	PROC_9	0.753	3.142	1.144				
Physical evidence (PHYC)	PHYC_1	0.897	3.150	1.175	0.836	0.838	0.901	0.753
	PHYC_2	0.849	3.296	1.168				
	PHYC_3	0.856	3.138	1.096				
Involvement (INVO)	INVO_1	0.869	3.332	1.170	0.824	0.824	0.895	0.739
	INVO_2	0.847	3.255	1.142				
	INVO_3	0.864	3.117	1.129				
Flow (FLOW)	FLOW_1	0.896	3.393	1.191	0.883	0.885	0.919	0.741
	FLOW_2	0.866	3.433	1.211				
	FLOW_3	0.848	3.312	1.128				
	FLOW_4	0.831	3.344	1.158				
Impulse buying (IMPU)	IMPU_1	0.861	3.223	1.142	0.878	0.878	0.916	0.732
	IMPU_2	0.861	3.215	1.158				
	IMPU_3	0.870	3.069	1.133				
	IMPU_4	0.829	3.093	1.149				

Table 5: Heterotrait-monotrait results (HTMT) for discriminant validity

	PROD	PROM	PLAC	PEOP	PROC	PHYC	INVO	FLOW	IMPU
PROD									
PROM	0.802								
PLAC	0.783	0.750							
PEOP	0.692	0.660	0.690						
PROC	0.670	0.705	0.710	0.699					
PHYC	0.677	0.664	0.652	0.691	0.693				
INVO	0.765	0.753	0.785	0.728	0.721	0.659			
FLOW	0.658	0.697	0.730	0.709	0.792	0.788	0.693		
IMPU	0.553	0.656	0.531	0.589	0.642	0.728	0.581	0.681	

### Structural Model

As the constructs were validated as shown above, this step was to assess the structural model and the hypothesized relationships. Before checking the results of hypothesis tests, collinearity was examined by the variance inflation factor (VIF) values of the exogenous constructs with each of the endogenous constructs. Our model has three endogenous constructs, namely, INVO, FLOW, and IMPU. As shown in Table 6, the VIF values ranged from 1.538 to 2.470 were all well below threshold value 3, it is to say that there was no collinearity issue ( $\geq 5$ ) among the six exogenous constructs in this study which might affect the accuracy of the results (Hair et al., 2017). In addition, the R-squared ( $R^2$ ) values of the endogenous constructs were examined to test the

model’s explanatory power. The R<sup>2</sup> of the impulse buying construct was 0.390, indicating that 39% of the variance in the impulse purchase via live streaming could be explained by the predictor constructs. The R<sup>2</sup> of involvement and flow were 0.579 and 0.642, meaning that the antecedents could explain 57.9% and 64.2% of the variances in the construct respectively.

Table 6: The VIF values of predictor constructs

INVO:	PROD	PROM	PLAC	PEOP	PROC	PHYC
VIF	2.470	2.300	2.190	2.097	2.294	1.943
FLOW:	PROD	PROM	PLAC	PEOP	PROC	PHYC
VIF	2.470	2.300	2.190	2.097	2.294	1.943
IMPU:	INVO	FLOW				
VIF	1.538	1.538				

As regards the predictive power of the structural model, we examined the out-of-sample predictive error, comparing root-mean-squared error (RMSE) and mean absolute error (MAE) values produced by PLS-SEM with the values yielded by the linear regression model (LM) for each indicator of the outcome construct (IMPU) by running the PLSpredict procedure with ten repetitions (Shmueli et al., 2016; Shmueli, 2019). As shown in Table 7, the PLS-SEM model has lower values compared to the values of LM for all the indicators of the outcome construct (IMPU) in terms of RMSE and MAE. Accordingly, it is concluded that the model proposed has a high predictive power.

Table 7: The results of PLSpredict procedure

		impu_1	impu_2	impu_3	impu_4
RMSE	PLS	0.969	0.987	0.981	0.999
	LM	1.020	1.042	1.013	1.013
MAE	PLS	0.743	0.788	0.792	0.781
	LM	0.792	0.845	0.817	0.812

Next, the relevance and significance of the structural paths were evaluated by bootstrapping (5000 samples). Table 8 and Figure 2 summarize the results of the bootstrapping of structural paths. H1a to H6a postulate that each of Ps affects *Involvement* positively. Of the six exogenous constructs, PLAC has the strongest positive impact (0.202) on INVO, followed by PROD (0.185), PEOP (0.176), and PROC (0.165). H1b to H6b assume that each of Ps influences *Flow* positively. As can be seen, PROC has the most positive effect (0.328) on FLOW, followed by PHYC (0.282), PLAC (0.152), and PEOP (0.126). Assuming a 5% significance level, the *t*-values estimated from the bootstrapping should exceed 1.960. As shown in Table 8, four exogenous relationships are not statistically significant (H2a: PROM→INVO, *t* = 1.926; H6a: PHYC→INVO, *t* = 0.699; H1b: PROD→FLOW, *t* = -0.264; H2b: PROM→FLOW, *t* = 1.242). Regarding the endogenous constructs, the results show that INOV and FLOW have a positive effect (0.214) and (0.474) on IMPU with *t*-value of 2.926 and 6.483 respectively, thus both H7 (Involvement has a positive influence on impulse buying) and H8 (*Flow* has a positive influence on impulse buying) were statistically supported at 5% level. In terms of mediation effect, Table 9 shows that INVO has a full mediating effect on the relationships between PROD and IMPU, while FLOW mediates effects partially between three relationships: PLAC and IMPU, PROC and IMPU, PHYC and IMPU.

Table 8: The results of hypothesis testing

Path Relationship	Original sample	Sample Mean	S.D.	T-Statistics	P-value	2.5% CI	97.5% CI
H1a: PROD -> INVO	0.185**	0.184	0.07	2.648	0.009	0.054	0.326
H2a: PROM -> INVO	0.145 ns	0.143	0.076	1.926	0.055	-0.002	0.293
H3a: PLAC -> INVO	0.202**	0.205	0.073	2.760	0.006	0.058	0.342
H4a: PEOP -> INVO	0.176**	0.174	0.066	2.661	0.008	0.04	0.302
H5a: PROC -> INVO	0.165*	0.171	0.082	2.025	0.044	0.01	0.327
H6a: PHYC -> INVO	0.047 ns	0.044	0.067	0.699	0.485	-0.082	0.18
H1b: PROD -> FLOW	-0.018 ns	-0.016	0.066	-0.264	0.792	-0.145	0.114
H2b: PROM -> FLOW	0.088 ns	0.092	0.071	1.242	0.215	-0.046	0.229
H3b: PLAC -> FLOW	0.152*	0.145	0.067	2.262	0.025	0.008	0.271
H4b: PEOP -> FLOW	0.126*	0.128	0.063	2.015	0.045	0.008	0.253
H5b: PROC -> FLOW	0.328***	0.325	0.067	4.893	0.000	0.192	0.455
H6b: PHYC -> FLOW	0.282***	0.285	0.070	4.011	0.000	0.149	0.424
H7: INVO -> IMPU	0.214**	0.215	0.073	2.926	0.004	0.073	0.359
H8: FLOW -> IMPU	0.474***	0.475	0.073	6.483	0.000	0.328	0.616

S.D.: Standard Deviation, \* *p* < 0.05, \*\* *p* < 0.01, \*\*\* *p* < 0.001, ns-not significant,

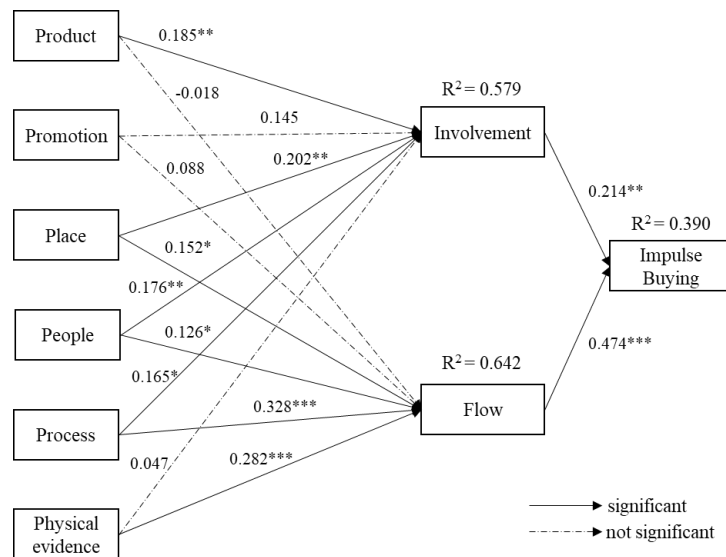

Figure 2: The results of the structural paths

Table 9: The results of mediating effects testing

Mediation Path	Indirect Effect	T-Statistics	P-value	Direct Effect	T-Statistics	P-value	Mediation
PROD->INVO->IMPU	0.040*	2.124	0.035	0.031	0.789	0.431	full
PROD->FLOW->IMPU	-0.008	-0.259	0.800	0.031	0.789	0.431	no
PROM->INVO->IMPU	0.031	1.416	0.158	0.073*	2.071	0.039	no
PROM->FLOW->IMPU	0.042	1.140	0.255	0.073*	2.071	0.039	no
PLAC->INVO->IMPU	0.043	1.934	0.054	0.115**	3.113	0.002	no
PLAC->FLOW->IMPU	0.072*	2.229	0.027	0.115**	3.113	0.002	partial
PEOP->INVO->IMPU	0.038	1.909	0.057	0.097**	2.607	0.009	no
PEOP->FLOW->IMPU	0.060	1.900	0.060	0.097**	2.607	0.009	no
PROC->INVO->IMPU	0.035	1.572	0.117	0.191***	4.746	0.000	no
PROC->FLOW->IMPU	0.155***	3.938	0.000	0.191***	4.746	0.000	partial
PHYC->INVO->IMPU	0.010	0.630	0.525	0.143**	3.090	0.002	no
PHYC->FLOW->IMPU	0.133**	3.045	0.003	0.143**	3.090	0.002	partial

\*  $p < 0.05$ , \*\*  $p < 0.01$ , \*\*\*  $p < 0.001$

## CONCLUSION

Since ECL enables personal selling through live streaming, the appearance of salespeople in ECL's livestream room allows customers to shop as if they were in a physical store which can enhance customer shopping experience. The primary goal of this study is to investigate the influence of marketing mix on consumers' shopping experience in ECL from consumers' point of view and the outcome behavior of impulse buying. The research model adopted the e-commerce marketing mix for the context of ECL and built on the relationships of the shopping experience (product involvement and flow experience) to impulse purchase, and the e-commerce marketing mix to the shopping experience. Regards the former linkages, the study results revealed that both product involvement and flow experience have a positive effect on impulse buying via ECL, and the influence of flow experience ( $\beta = 0.474$ ,  $p < .001$ ) shows more stronger than product involvement ( $\beta = 0.214$ ,  $p < .01$ ). Therefore, it is advisable for sellers (salespeople) to focus on marketing activities that positively influence the customers' perception of their products and services and those that enhance customers' flow experience in the live streaming.

As regards the latter linkages, the results showed that not all elements of the e-commerce marketing mix have a positive impact on the shopping experience. *Place* (availability of the platform and customer service), *People* (attractiveness of streamer) and *Process* (interpersonal interactions) influence both product involvement and flow experience positively, but *Product* (product information) has a positive impact only on product involvement, and *Physical evidence* (atmosphere of livestream room) only on flow experience. On the contrary, *Promotion* (sales promotions activities) seems not to have a positive impact on product involvement and flow experience. Further, considering the mediating effect produced by the shopping experience, the results indicated that the relationship between *Product* and impulse buying is fully mediated by product involvement, and flow

experience partially mediates the respective effects of *Place, Process, and Physical evidence* on impulse buying. In other words, it is suggested that although *People* may encourage customers to engage in the selling process, it does not affect impulse buying through the experiences in ECL. *Promotion* has no effects on the shopping experience, but not surprisingly, it may direct customers toward purchasing impulsively when much more benefits are provided.

Given that marketing mix elements are means to an end, the study results also suggest that while performing the combination of *Product, Place, People, and Process*, salespeople (streamers) should concentrate their marketing efforts on enhancing their product presentation (*Product*) and providing more comprehensive and customer-needed information to induce them to engage in knowing the product. This will increase their product involvement, which in turn causes impulse buying. On the other hand, it is recognized that the effective combination of *Place* (e.g. kind customer service), *Process* (e.g. joyful interactions), and *Physical evidence* (e.g. pleasant atmosphere) can increase customers' flow experience, which evokes impulse purchase consequently.

Overall, this study has provided empirical evidence of the application of the e-commerce marketing mix on research of impulse purchase in ECL. However, it must be noted that the survey was limited to consumers of ECL in China, and the type of platforms they use was not limited. Therefore, the study can be improved in terms of data sources and research fields in the future. Future studies could consider expanding the sample size to include consumers from other countries and regions.

## REFERENCES

- Arora, A., Glaser, D., Kluge, P., Kim, A., Kohli, S., & Sak, N. (2021). *It's showtime! How live commerce is transforming the shopping experience*. McKinsey Digital. <https://www.mckinsey.com/capabilities/mckinsey-digital/our-insights/its-showtime-how-live-commerce-is-transforming-the-shopping-experience#/>.
- Booms, B. H., & Bitner, M. J. (1981). *Marketing strategies and organization structures for service firms*. In: *Marketing of Services*, American Marketing Association, Chicago, 47-51.
- Bu, L., Wang, J., Wang, K. W., & Zipser, D. (2023). *Powering growth in China with social and live commerce*. McKinsey & Company. <https://www.mckinsey.com/cn/our-insights/our-insights/powering-growth-in-china-with-social-and-live-commerce>.
- Celsi, R. L., & Olson, J. C. (1988). *The role of involvement in attention and comprehension processes*. *Journal of Consumer Research*, 15, 210–224. <https://doi.org/10.1086/209158>.
- Chan Yee-kwong R. (1997). *Demographic and attitudinal differences between active and inactive credit cardholders-the case of Hong Kong*. *International Journal of Bank Marketing*, 15(4), 117-125. <https://doi.org/10.1108/02652329710189375>.
- Chan, Tommy K.H., Cheung, Christy M.K. & Lee, Zach W.Y. (2017). *The state of online impulse-buying research: A literature analysis*. *Information & Management*, 54, 204–217. <https://doi.org/10.1016/j.im.2016.06.001>.
- Chang H. H., Lu Y. Y. & Lin S. C. (2020). *An elaboration likelihood model of consumer respond action to facebook secondhand marketplace: impulsiveness as a moderator*. *Information & Management*, 57(2), 103171. <https://doi.org/10.1016/j.im.2019.103171>.
- Csikszentmihalyi M. (1975). *Beyond Boredom and Anxiety*. Jossey-Bass Publishers.
- Csikszentmihalyi M. (1990). *Flow: The Psychology of Optimal Experience*. New York Harper and Row.
- Donna L., Hoffman, T. & Novak. P. (2018). *Editorial: Consumers and the Internet of Things*. *GfK Marketing Intelligence Review*, 10(2). <https://doi.org/10.2478/gfkmir-2018-0011>.
- Drossos, D. A., Kokkinaki, F., Giaglis, G. M., & Fouskas, K. G. (2014). *The effects of product involvement and impulse buying on purchase intentions in mobile text advertising*. *Electronic Commerce Research*, 13(6) 423–430. <https://doi.org/10.1016/j.elepar.2014.08.003>.
- Evrard, Y. & Aurier, P. (1996). *Identification and validation of the components of the person-object relationship*. *Journal of Business Research*, 37, 127-134. [https://doi.org/10.1016/0148-2963\(96\)00054-9](https://doi.org/10.1016/0148-2963(96)00054-9).
- Faisal, C. M. N., Fernandez-Lanvin, D., De Andrés, J., & Gonzalez-Rodriguez, M. (2020). *Design quality in building behavioral intention through affective and cognitive involvement for e-learning on smartphones*. *Internet Research*, 30, 1631–1663. <https://doi.org/10.1108/INTR-05-2019-0217>.
- Feng Jun & Lu Mei (2020). *The empirical research on impulse buying intention of live marketing in mobile internet era*. *Soft Science*, 34(12), 128-133,144. <https://doi.org/10.13956/j.ss.1001-8409.2020.12.20>.
- Floh A. & Madlberger M. (2013) *The role of atmospheric cues in online impulse buying behavior*. *Electronic Commerce Research and Applications*, 12 (6), 425-439. <https://doi.org/10.1016/j.elepar.2013.06.001>.
- Ghiffarin, A. R., Priyandari, Y., & Liquidanu, E. (2019). *Marketing analysis for e-commerce improvement in small and medium enterprise of batik using e-commerce marketing mix model*. *IOP Conf. Series: Materials Science and Engineering* 495 012044. <https://doi.org/10.1088/1757-899X/495/1/012044>.
- Gong X. X. & Jiang X. T. (2023). *Understanding consumer impulse buying in livestreaming commerce: the product involvement perspective*. *Frontier in Psychology*, 1-18. <https://doi.org/10.3389/fpsyg.2023.1104349>.
- Gong X. X., Ye Z. L., Wu Y. P. & Liu J. Y. (2019). *Research on the influencing mechanism of atmosphere clue on impulse purchase intention in live streaming context*. *Chinese Journal of Management*, 16(6), 875-882. <http://www.cnki.net/KCMS/detail/detail.aspx?dbcode=CJFD&dbname=CJFDLAST2019&filename=GLXB201906010&uniplatform=OVERSEA&v=1yQLZgKrVsvqT43bna6kS5NycPEv9vZAW986ip-vi3avDVWscqHdBxn5Wo2Jj10>.



- Henseler, J., Dijkstra, T. K., Sarstedt, M., & Ringle, C. M. (2014). *Common beliefs and reality about PLS*. *Organizational Research Methods*, 17(2), 182-209. <https://doi.org/10.1177/1094428114526928>.
- Hair, J. F., Matthews, L. M., Matthews, R. L., & Sarstedt, M. (2017). *PLS-SEM or CB-SEM: Updated guidelines on which method to use*. *International Journal of Multivariate Data Analysis*, 1, 107-123. <https://doi.org/10.1504/IJMDA.2017.087624>.
- Hair, J. F., Risher, J. J., Sarstedt, M., & Ringle, C. M. (2019). *When to use and how to report the results of PLS-SEM*. *European Business Review*, 31, 2-24. <https://doi.org/10.1108/EBR-11-2018-0203>.
- Hair, J. F., Sarstedt, M., Ringle, C. M., & Mena, J. A. (2012). *An assessment of the use of partial least squares structural equation modeling in marketing research*. *Journal of the Academy of Marketing Science*, 40, 414-433. <https://doi.org/10.1007/s11747-011-0261-6>.
- Henseler, J., Ringle, C. M., & Sarstedt, M. (2015). *A new criterion for assessing discriminant validity in variance-based structural equation modeling*. *Journal of the Academy of Marketing Science*, 43, 115-135. <https://doi.org/10.1007/s11747-014-0403-8>.
- Ho C. I., Liu Y. Y., & Chen M. C. (2022). *Factors influencing watching and purchase intentions on live streaming platforms: from a 7ps marketing mix perspective*. *Information* 13, 239. <https://doi.org/10.3390/info13050239>.
- Hoffman D. L. & Novak T. P. (1996). *Marketing in hypermedia computer-mediated environments: conceptual foundations*. *Journal of Marketing*, 60 (3) 50-68. <https://doi.org/10.2307/1251841>.
- Hoffman, T. P., & Novak, D. L. (2009). *Flow online: lessons learned and future prospects*. *Journal of Interactive Marketing*, 23(1), 23-34. <https://doi.org/10.1016/j.intmar.2008.10.003>.
- Ivy, J. (2008). *A new higher education marketing mix: the 7Ps for MBA marketing*. *International Journal of Educational Management*, 22(4), 288-299. <https://doi.org/10.1108/09513540810875635>.
- Kotler, P., & Armstrong, G. (1989). *Principles of Marketing, 4th ed.*, Prentice-Hall, Englewood Cliffs, N.J.
- Koufaris M. (2002). *Applying the technology acceptance model and flow theory to online consumer behavior*. *Information Systems Research*, 13(2), 205-223. <https://doi.org/10.1287/isre.13.2.205.83>.
- Li Y. (2020). *Research on The Impact of E-commerce Live Broadcasting on Consumers' Impulsive Buying*. Thesis, Harbin Engineering University. <https://doi.org/10.27060/d.cnki.ghbcu.2020.001529>.
- Liu Q. Y. (2022). *Research on wechat official account service of Liaoning university library based on 7ps theory*. Thesis, Liaoning University, China. <https://doi.org/10.27209/d.cnki.glniu.2022.001215>.
- Liu Y., Li H. X., & Hu F. (2013). *Website attributes in urging online impulse purchase: An empirical investigation on consumer perceptions*. *Decision Support Systems*, 55(3), 829-837. <https://doi.org/10.1016/j.dss.2013.04.001>.
- Liu Z. Y., Zhao X. H. & Long W. (2020). *The Formation Mechanism of Consumers' Purchasing Intention in Online Celebrity Live Streaming Based on Grounded Theory*. *Chian Business and Market*, 34(8), 48-57. <https://doi.org/10.14089/j.cnki.cn11-3664/f.2020.08.005>.
- Marsh, S. A. & Jackson, H. (1996). *Development and validation of a scale to measure optimal experience: the flow state scale*. *Journal of Sport & Exercise Psychology*, 18, 17-35. <https://doi.org/10.1123/jsep.18.1.17>.
- Martin, C. L. (1998). *Relationship marketing: a high-involvement product attribute approach*. *Journal of product & brand management*, 7(1), 6-26. <https://doi.org/10.1108/10610429810209700>.
- McCharty, E.J. (1964). *Basic Marketing: A Managerial Approach*. 2nd Edition, Irwin, New York.
- Ming M. M. (2021). *Research on the influencing factors of consumers' impulse purchase intention in the interactive content of e-commerce live streaming*. Thesis, Shandong University. <https://doi.org/10.27272/d.cnki.gshdu.2021.001847>.
- Mittal, B. (1989). *Measuring Purchase-decision involvement*. *Psychology & Marketing*, 6(2), 147-162. <https://doi.org/10.1002/mar.4220060206>.
- Mittal, B., & Lee, M.S. (1989). *A causal model of consumer involvement*. *Journal of Economic Psychology*, 10(3), 363-389. [https://doi.org/10.1016/0167-4870\(89\)90030-5](https://doi.org/10.1016/0167-4870(89)90030-5).
- Pogorelova, Elena V., Yakhneeva, Irina V., Agafonova, Anna N., & Prokubovskaya, Alla O. (2016). *Marketing mix for e-commerce*. *International Journal of Environmental & Science Education*, 11(14), 6744-6759. <https://eric.ed.gov/?id=EJ1115907>.
- Rook, D. W. & Fisher R.J. (1995). *Normative influences on impulsive buying behavior*. *Journal of Consumer Research*, 22(3), 305-313. <https://doi.org/10.1086/209452>.
- Rook, D. W. (1987). *The buying impulse*. *Journal of Consumer Research*, 14(2), 189-199. <https://doi.org/10.1086/209105>.
- Shmueli, G., Ray, S., Estrada, J. M. V., & Chatla, S. B. (2016). *The elephant in the room: Predictive performance of PLS models*. *Journal of Business Research*, 69(10), 4552-4564. <https://doi.org/10.1016/j.jbusres.2016.03.049>.
- Shmueli, G., Sarstedt, M., Hair, J. F., Cheah, J. H., Ting, H., Vaithilingam, S., & Ringle, C. M. (2019). *Predictive model assessment in PLS-SEM: Guidelines for using PLSpredict*. *European Journal of Marketing*, 53(11), 2322-2347. <https://doi.org/10.1108/EJM-02-2019-0189>.
- Sun, K., Liu, L. H., & Liu, C. L. (2022). *Consumers' impulsive purchase intention from the perspective of affection in livestreaming e-commerce*. *China Business and Market*, 36(1), 33-42. <https://doi.org/10.14089/j.cnki.cn11-3664/f.2022.01.004>.
- Sun, Y., Shao, X., Li, X. T., Guo, Y., & Nie, K. (2019). *How live streaming influences purchase intentions in social commerce: An IT affordance perspective*. *Electronic Commerce Research and Applications*, 37, 100886. <https://doi.org/10.1016/j.elelap.2019.100886>.



- Wei, J. F., Li, M. N., & Liu, B. P. (2022). Research on the influence of anchor characteristics on consumers' impulse purchase intention in e-commerce livestreaming. *China Business and Market*, 36(4), 32-42. <https://doi.org/10.14089/j.cnki.cn11-3664/f.2022.04.003>.
- Wu, I. L., Chen, K. W., & Chiu, M. L. (2016). Defining key drivers of online impulse purchasing: A perspective of both impulse shoppers and system users. *International Journal of Information Management*, 36(3), 284-296. <https://doi.org/10.1016/j.ijinfomgt.2015.11.015>.
- Xu, H., Qu, H. J., & Cai, J. Z. (2021). Influencing factors of apparel consumers' impulsive purchase willingness in the context of webcasting. *Journal of Donghua University (Natural Science)*, 47(5), 111-120. <https://doi.org/10.19886/j.cnki.dhdz.2020.0189>.
- Yin, Y., & Wang, Y. L. (2022). The influence of e-commerce live streaming on users' purchase intention--based on the characteristics of the host and the perspective of social presence. *Journal of Hubei University of Science and Technology*, 42(1), 26-33. <https://doi.org/10.16751/j.cnki.hbkj.2022.01.005>.
- Yue, H., & Lu, S. (2021). Factors affecting Chinese consumers' impulse buying decision of live streaming e-commerce. *Asian Social Science*, 17(5), 16-32. <https://doi.org/10.5539/ass.v17n5p16>.
- Zaichkowsky, J. L. (1985). Measuring the involvement construct. *Journal of Consumer Research*, 12(3), 341-352. <https://doi.org/10.1086/208520>.
- Zaichkowsky, J. L. (1994). The personal involvement inventory: reduction, revision, and application to advertising. *Journal of Advertising*, 23(4), 59-70. <https://doi.org/10.1080/00913367.1943.10673459>.

## Artificial Intelligence (AI), Rio Tinto and Firm Leading-Edge AI Competitiveness

John R. Hamilton <sup>1,\*</sup>  
Stephen J. Maxwell <sup>2</sup>

\*Corresponding author

<sup>1</sup> Adj. Chair Professor, James Cook University, Cairns, Australia, John.Hamilton@jcu.edu.au

<sup>2</sup> Researcher, Doctor, James Cook University, Cairns, Australia, Stephen.Maxwell@my.jcu.edu.au

### ABSTRACT

This study frames AI into five successive generational AI All development phases of increasing complex program and platform diversity, whilst drawing on involving increasingly diverse and rich 'global' sources of 'relevant' data. It considers the AI techniques Rio Tinto applies at each generational level. It recognizes the AI complexities of resourcing, technologies, connectivities integrations, intelligent devices, and data-recall capacities on leading-edge firms and their ongoing competitiveness. It proposes a leading-edge firm timeline stagewise strategic AI feedback model.

*Keywords:* AI generation, big data complexity, AI techniques, strategic AI competitiveness, machine learning, intelligent augmented AI, deep learning AI, super-intelligent AI.

### INTRODUCTION

Artificial intelligence (AI) encompasses the ability of a computer program or a digitally connected device to think, learn and respond in a similar way to how humans learn to understand, and influence their environment. This field of programmed interconnectedness technologies also tries to make computing 'smarter'. AI encompasses complex information processing and programming problems that have their origins in some aspects of biological or business data and its' information processing (Marr, 1975). Today's advances in AI have made the sector more complicated and more difficult to deliver high-quality business information in an instant, and this can make the difference between success, or survival, or bankruptcy (Bharadiya, 2023).

Pallathadka et al. (2021) present AI across financial industries as often involving: machine learning, complexities solutions and diversities algorithms, and as helping to achieve: better consumer connectivities, supply chain efficiencies, design improvements, product qualities control methods, and new consumer experiences - and all at low cost! The steady growth in AI applications has now permeated human lives and business opportunities. Today, AI-adoption in business helps anticipate and learn from data. It helps drive competitiveness, re-engineer products/services, remap business strategies, improve human understanding, advances calculations, and solve complex business unknowns (Sestino & De Mauro, 2022).

### The AI Business Domain

AI is often based on capabilities being actioned of on functionalities of devices. AI enlists applicable digital AI software systems and offers abilities to analyse and identify basic repetitive patterns, or pattern differences within complex mechanisms including big data optimization, image recognition, machine learning (ML), robotics, and device automation across chosen firm or industrial sectors. Some AI can enable machinery, or devices, to learn and design self-improvements. Zohuri and Moghaddam, (2020) and others support different iteration levels of AI involvement in business processes. AI permeates business at many levels. AI has roughly developed cyclically from simple mechanical rule-based response-driven AI, through to increasingly-complex generational levels of AI as presented below. These five generations align with major shifts in (1) latest digital capabilities and trends, (2) ongoing industrial/developer creative technologies and (3) AI engagement breakthrough cycles. These cycles also marry with futurists considerations (Anon7, 2023, Anon8, 2023), and they are not specifically based on academic papers.

Simple reactive-AI systems receive basic digital information and is programmed to initiate specific responses. This first generation AI system consistently delivers in an unsupervised way, the same basic, specific conditional alterations to the same situation. Further, it does not learn from recurrent or variant digital information situations. Reactive-AI systems cannot initiate future re-directive change actions. However, they can encompass programs including: spam filters, SPSS's statistical analyses, or a Taxi/Uber booking service or a business call-line's filtering system to connect to the chosen business-response sector. This level of software development delivers outcomes like basic AI nature language processing (recognizing/responding and image recognition), but sometimes they may engage basic machine learning and/or neural network algorithms to complete specific tasks.

Second generation AI systems draw upon available memory but in a limited and supervised way. This approach can store knowledge, and use predictive algorithms: to recall, re-collate and train large volumes of data, to compare past and present observed, experiential, or actioning data, and to build further comparative knowledge, whilst also offering complex, assessed,

best-option predictions regarding changeable task components and their redirection. This limited-AI system often involves basic machine learning, and is applicable to chatbox assessments, or to assessing fixed optimal, directed movements of semi-autonomous vehicles in warehouses, or to on-road vehicle activities. However these software-actioned capabilities do not specifically store each specific software action for future differential reuse.

Third generation AI systems involve detailed intelligent augmented machine learning approaches. This computer programming approach delivers coding containing machine language instructions ‘read’ by ‘intelligent’ machines, interpreted as binary program data and augmented with assembly languages or high-level languages via hexadecimal or octal decimal program data. This augmented machine language is designed towards creating very-specific reactive real-time responses - capable of learning, adapting, responding, and sometimes developing specific responses, often along with a degree of ‘reliable’ intuition. However they cannot improve their functionality via gathered experiences, and can only respond to limited combinations of inputs.

For example third generation AI systems (augmented machine learning) are used precise medical measurement devices, or embedded in the operational electronics controlling vehicular engine activities, or in autonomous vehicle detection/control/direction systems or in flight simulators or in movies like ‘top gun maverick’, or even in chess matches, but today can be augmented with voice, virtual realities and powerful computing to merge relevant physical and virtual worlds whilst delivering global real-time digital and logical solutions.

A fourth generation AI system applies more advanced scenarios, data-storage developments and memory management. It operates at a deep-learning AI level and approaches human mind intelligence. This ‘mind’ intelligence AI approach allows emotive, conversational assessment and smarter decision making. It engages fluidity-of thought, memory-recall and emotional intelligence behaviors, and can process human commands and through their deep learning centres, and can adapt findings towards appropriate (and even future-forecasting) communicative interactions. As such, this is a tricky, complex, and comparative, and still-emerging, domain to program. Examples here include intelligent simulators and humanoid robots that mimic human behavior – such as: the ultra-realistic robot ‘Ai-Da Robot’ - who in 2023, both designed and 3D prototyped several commonly-used household items. This area of smart, autonomous robotics continues to expand across: personal assistance, entertainment, healthcare, education, and even into retailing.

A fifth generation AI system is one that can operate super-intelligently as a self-aware-AI instrument of technical, digital, emotional, consciousness, and intelligent competence capable of thinking and operating across multiple mental states. Super-intelligence is driven via specific software interfacing that can enable autonomous machinery to sense, comprehend and enact decisions on their own. Its human-brain inspired artificial neural networks bring the capability of cognitive and natural language towards mimicking, mastering and surpassing human intelligence processes. These artificial neural networks capture structured and unstructured data: as multi-level perceptions, as convolutional neural networking, and as recurrent networking systems - offering combined augmented flexibilities, and providing useful, reliable predictive problem solving deliverables. Examples here include supercomputers –that can resolve almost anything. To date, the fifth generation super-intelligent self-awareness and feelings assessment system has not been delivered, but it is very close and will become reality once the full scope of quantum computing becomes a successful reality.

The above five generations of AI are depicted as Figure 1. Simple reactive AI systems although widespread, generally access lowest levels of acquired data, whereas super-intelligent AI neural networks with vast reach and data complexities operationalize and integrate the other four generations of AI development plus other emerging technologies. Such fifth generation AI systems can potentially scope and solve any emergent inconsistency, or problem, to the level required, and in a very-specific manner.

This study now considers the firm Rio Tinto as a lead example of how key generational-level AI-related techniques can deliver results. This study recognizes AI operates across an expanding continuum where complexities of resourcing, engaged technologies, network-linked connectivities integrations, intelligent physical and virtual devices, and data-recall capabilities It recognizes each engaged technique presents business enhancements that when incorporated can influence overall firm operations whilst also delivering ongoing global, competitiveness repositioning.

## LITERATURE REVIEW

### **Rio Tinto’s Leading-Edge AI Business Model**

Rio Tinto has existed for 150+years, and today is the second largest global mining company. It operates in 35 countries and has a workforce of around 52,000 across six continents. Rio Tinto’s portfolio includes iron ore, copper, aluminium, lithium plus other materials required for everyday life, and for a world transition towards net zero carbon emissions. Its market capitalization is USD 130.24B (Anon1, 2022).

Across the last four 2019 -2022 financial years, Rio Tinto’s gross sale revenue ranged from USD 43.165B to USD 63495B, and its current 2022/23 financial year gross sales revenue is USD 55,554B. By mid 2028 shares in Rio Tinto are projected to grow by around +6.44% (Anon1, 2022).

Rio Tinto is focused towards best operator, with greater consistency in operational performance, whilst delivering impeccable environmental, social, and governance credentials, excelling in development, and strengthening its social licence. In-line with societal decarbonizing, Rio Tinto is also shifting to underground autonomous vehicles and renewable power. This is driving demand for more copper aluminium, lithium and high-quality iron ore from globally competitive mines. Thus Rio Tinto focuses towards finding better ways to work and towards a determination to innovate. Hence it strives to create partnerships in solving problems, to create win-win, and to meeting opportunities, whilst also being a business with a commodity-mix aligned with evolving customer demand in a decarbonizing world. Thus it aims to find better ways to engage its DNA (Anon1, 2022).

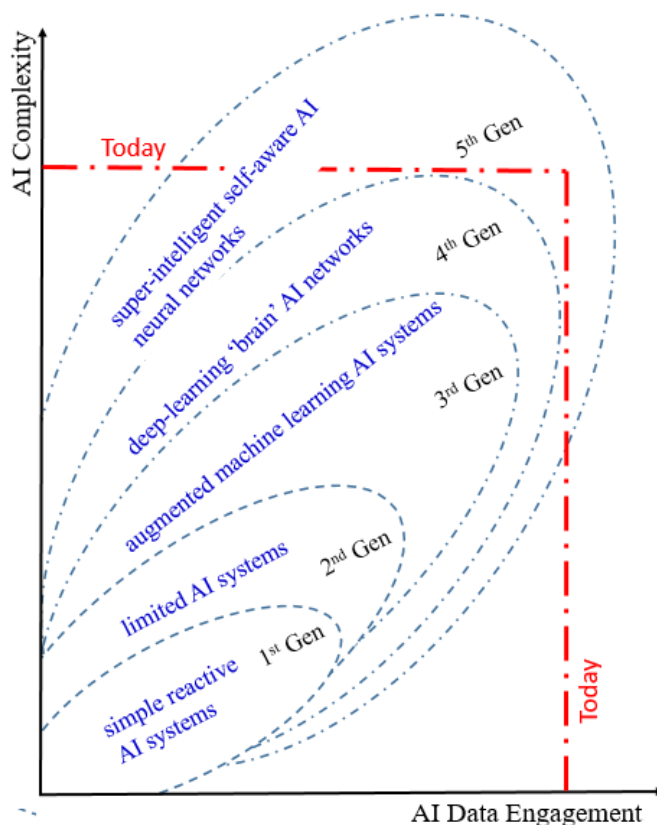

Source: This study.

Figure 1: Specificity/complexity of data deployed under successive generations of AI

Rio Tinto engages new technologies, data science, machine learning and artificial intelligence throughout their current strategic business model. Their need for innovation is continually growing as are their ways of producing materials like aluminium and scandium. They already sustainably block-chain-label their aluminium product, and have sold iron ore and aluminium via block chain. The beneficial outcome of copper, aluminium, iron ore, lithium and other minerals towards net zero or renewable energy production are improved and continually monitored. Mine yields and efficiencies, along with the lowering of waste streams, are continually improved (Anon2, 2022).

Globally, Rio Tinto has access to over four million hectares of land Its 2023 R&D technology roadmap aims to explore, design, build, operate and close chosen operations by improving productivity, maximizing value from each orebody, equipment utilization, automation, energy efficiency, energy storage, green processing, reducing capital intensity, reducing water consumption reducing frontline hazards, and people wellbeing management (Anon1, 2022).

**Rio Tinto Digitally Connected Techniques**

Since April 2019 ‘Gudai-Darri’ is Rio Tinto’s most technologically advanced iron ore mine. it engages over one hundred digital technologies, some of which are presented in Table 1, with each displayed diagrammatically across the rows of Figure 2 below. To date Rio Tinto has delivered generation 1 to generation 4 AI solutions across its mines, and it continues to develop further generation 4 and 5 AI technologies (marked as capital red ‘X’). But, it has not yet delivered generation 5 AI solutions.

Today Rio Tinto’s AI is predominantly working towards or at generation 4 AI levels. However, its innovation continues to advance with these four generations. For example, its new Bioiron (trademark IP) approach enlists sustainable biomass, microwave energy and AI to efficiently replace coal across the iron to steel reduction process. This also enhances its decarbonization.

The fifth generation AI system with super-intelligence, self-awareness, emotional consciousness, and sensory capabilities across multiple mental states is now being targeted by Rio Tinto as a precursor model prior to the completion of quantum

computers. Quantum computing offers the potential introduction of robotically-interfacing self-modifying autonomous machinery – possibly collectively deploying AI-supported neural networks, senses, comparisons, comprehensions, and machine-specific smart decisions. This structured and unstructured big data intelligence level likely surpasses human intelligences, offering combined augmented autonomous functionality flexibilities, whilst also providing optimized predictive problem solving activity analytics. Thus Rio Tinto continues to draw on creative technologies and build new innovative AI techniques and applications that likely facilitate an enhanced AI-supported competitiveness position.

Table 1: AI Deployment Techniques and Applications at Rio Tinto  
Rio Tinto Iron Ore AI Engaged in Australian Mining Operations

AI Deployed	Gen 1	Gen 2	Gen 3	Gen 4	Gen 5
1 Near-real-time robotic ore sampling/grading/mine-feedback laboratory plus the data analytics	x	x			
2 23*CAT 793F battery-driven autonomous haul trucks	x	x			
3 4*CATMD autonomous drills	x	x	x		
4 Autonomous dust suppression water carts	x	x			
5 Autonomous dozers, graders, loaders, and shovels complete mine operational fleet - with iron ore grades controlled by blast hole data	x	x			
6 World's first fully autonomous and remotely monitored long distance, heavy-haul rail network, and in the future maybe ships	x	x	x		
7 Digital replica processing plant to pretest situations before processing	x	x	x	x	x
8 Mine digital twinning (visually navigates physical asset, plans work against 3D (to scale) gaming engine model & accesses/views associated AI tech data & documents and VR interactively PLUS virtually trains operators	x	x	x	x	x
9 34MW (83000 solar panels) on-site solar/wind powering 33% of the mines requirements plus a 1GW off-site solar/wind additional renewables power support system	x				
10 Field mobility devices for all personnel	x	x	x		
11 Low maintenance down-time removable rotatable 74 bucketwheel reclaimer	x				
12 Heavy mobile equipment (HME) warehouse robotics and laser-guided automatic vehicles to IoT automate pallet frame handling	x	x	x		
13 Real-time tablet solutions (paperless field mobility)	x	x	x		
14 Master remote control of all field operations	x	x	x	x	
15 Digital training and field-action simulators	x	x	x	x	
16 Mining artificial intelligence	x	x	x	x	x
17 Sensor based ore sorting	x				
18 Mine-of-Future layered technologies	x	x	x	x	x
19 3D mine analysis gaming engine sees inside operations, dives down for detailed information	x	x	x		
20 Robotic drilling and ore sampling	x	x	x		
21 Big data 3D analysis	x	x	x		
22 Immersive technologies	x	x	x	x	
23 Near-earth drones data robotics autonomy	x	x	x		
24 Mine-to-port VR oversight	x	x	x		
25 VR drone meshing	x	x	x	x	
26 Remote VR warehouse monitoring	x	x	x		
27 Value chain visualization	x	x	x	x	x
28 Holistic digital mine site exploration	x	x	x	x	

RED 'X' = DEVELOPING

1 Robotic Lab Sampling



5 Autonomous Grader

2 Haul Truck



6 AI Train

3 Autonomous Drill



7 Digital 3D Mine/Plant

4 Robot Water Cart



8 Digital Twinning



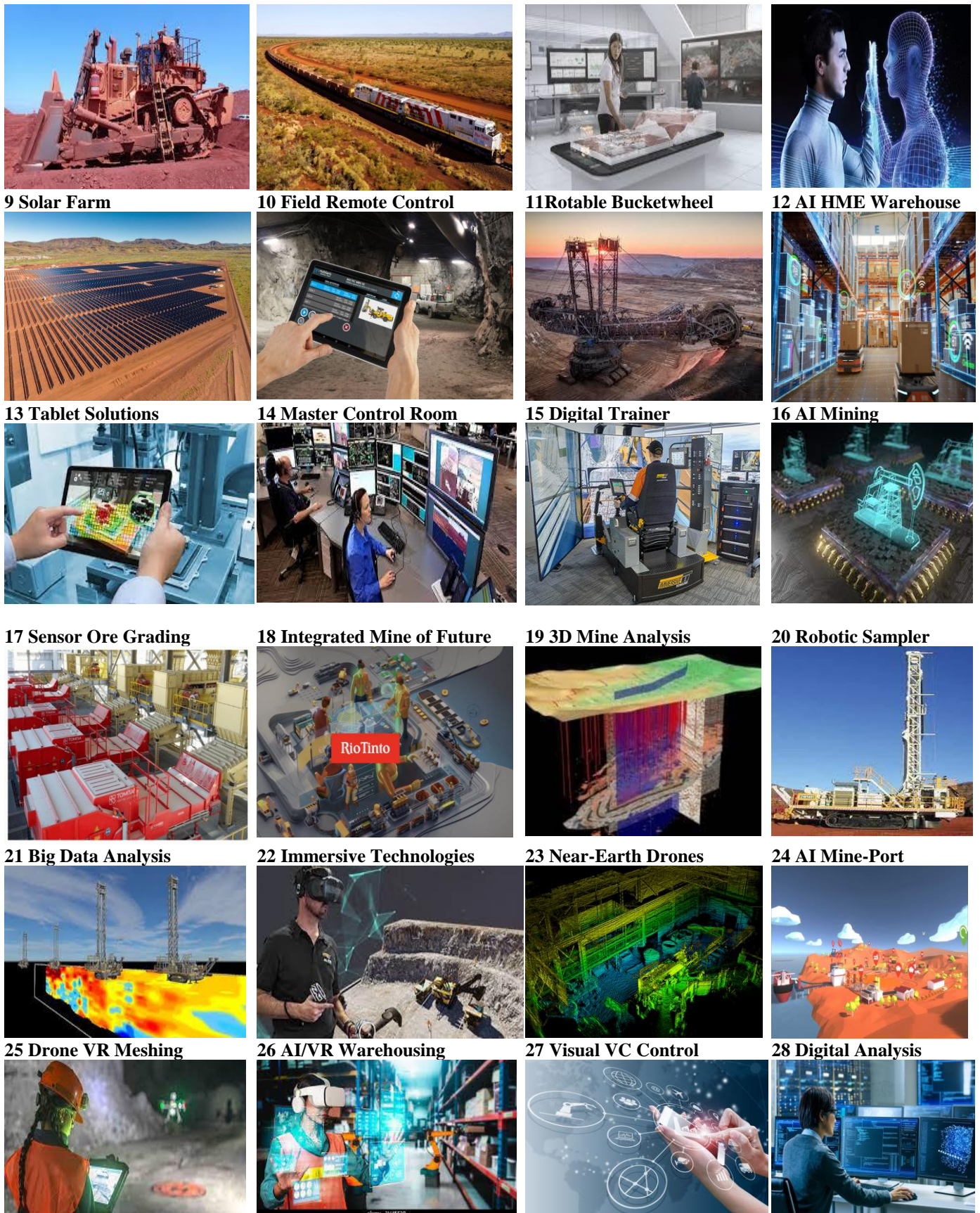

Figure 2: Rio Tinto Digitally-Related Techniques (sources Google Images and RioTinto.com)

**ANALYSIS**

**Mine Meshing**

Rio Tinto continues to enhance its new-age logistics approach as a mine mesh - integrating all its digital global intelligence systems across multiple platforms and servers. These integrate into a seamless pit-to-port, layered, 3D/4D continually-updating

process line, where all experiences and decision making is possible by intelligent machines or by human overrides (Anon2, 2022).

Today the world's most intelligent mine (Gudai-Darri) continues to disrupt traditional mining (Chan, 2022). It continues working towards the cohesive and collective networking of all assets into one digital connectivities decision making system - where any decision can be made 'in a microsecond.' Mine meshing brings digital full-mine visibility. For example Microsoft Azure's digital twinning gathers, integrates and extracts data and special intelligence graphs into models and interactions from across the mine's real world IoE sensors. It adds historical data and allows real-world interface modelling of the entire value relationships and interactions between the mine operator, spaces, and devices. This allows a drill down to individual assets and AI predicted setting suggestions, and to then make informed decisions with ability to simulate/predict downstream effects of such planned actions. Thus changes can be assessed and implemented virtually with an overall aim to deliver a system which understands in microsecond, manages an unplanned event, assesses past experiences, uses market intelligences and ensures value-over-volume (Anon6, 2023).

Mine meshing technology provides interconnected, seamless, overall digital mine experience, visibility, and toolkits to optimize productivity. Currently, there are more than one hundred approaches that mining incorporates including:

- Augmented realities (AR) where the mine mesh sees (1) digital processing plant real-time accessibilities (workforce, or fully integrated automation/autonomous/simulation systems), (2) technologies interconnecting logistics and the entire mining value chain, and (3) real-time sampled, lab-analyzed ore-body control-limit data.
- An autonomous drilling system (ADS) that safely tracks and pursues best grade seams of the ore body
- Remote in-city operators/controllers engaging analytics, machine learning and robotics to drive improvements in mining and/or business outcomes
- Virtual reality (VR) modules enable the solution to complex activities
- Mixed reality (MR) and extended reality (XR) simulations to test and/or guide new approaches
- 360 degrees 'complete' surroundings capture of any task allowing the on-demand workforce to fix problems and reset tasks
- Smart (autonomous) robotics capturing data everywhere as an internet of everything (IoE)
- Drone GPS mapping, recording across mine and logistical activities engages Rio Tinto's visualisation 3D gaming engine. It allows viewing over a site, collecting diagnostics, and assessing against accumulated information.
- Remotely operated vehicles (ROVs) real-time 3D mapping and checking slopes, crests and walls for safety risks, etc.
- Data-driven mine assets capturing and adding to digital IoE integration
- Marketplace-led demand-driven logistical supply chain actions specifically-generating additional value capabilities and delivering secure, real-time targeted outcomes
- Blockchain security across chosen contracted deliverable product mixes
- Agile, specific, block-chain labelled, blending/combining of mine ore grades to best-fit-end-user processing requirements and enable agile qualities/blending responses linked to marketplace demands
- Machine learning and predictive analytics help anticipate marketplace conditions and guide better mine output decision making
- Real-time mine mesh visualization across Australian mining operations through to the Singapore sales/marketing hub allows optimized shipping schedules of (what cargo, what size, what grade, what timeframe, what destination, what ship)
- Integrated GPS tracking of ships (largest biggest-draft-ships aimed to deepest berth pockets)
- Rio's AI historical data tells best mine ore to use for particular end-user order
- Advanced resource management system planning systems now reduce 3-to-4 weeks historical scheduling to 2 days
- AI/BI and big data technologies data sharing includes digital partners like Microsoft, Apple, Caterpillar, etc.
- AI software encompasses: locations, speeds, directions materials, efficiencies, safely, productivity, predictive maths, clever computer coding, powerful multi-level software, operations centres adding identified opportunities for improvements/efficiencies, geology, geotechnical, drill/blast, production/planning, visualized surfaces/sub-surface features, integrates analytics/sensory tools for better decision-making
- Dynamic learning systems operating within mesh visualizations
- Sustainable mine decarbonizing by lessening diesel fuels and engaging substitute enviro fuels
- Decarbonizing energy demands using solar and wind renewables.

## DISCUSSION

Rio Tinto remains on a progressive pathway to advancement, low cost delivery, and consumer connectivity. It remains not yet satisfied with its total suite of deliverables, and it still imagines things like at Gudai-Darri using predictive analytics to self-check machinery component conditions and to use AI and AR to check as required before non-scheduled maintenance can occur. This in-turn minimizes downtime. Currently Rio Tinto is focused on the following five domains

- Sustainability and a move towards zero emissions, along with digital connectivities to drive real-time efficiencies
- Predictive analytics to deliver real-time scheduling/tracking/ordering, augmented realities, and smart resource allocation solutions



- Mine ventilation-on-demand to reduce energy consumption underground below its current 50% of underground mining cost
- All electric and electronic digital mining delivered through autonomous and digital solutions each reducing costs and contributing towards further decarbonization
- Global logistics ensuring complete mine to client individual order completion is just-in-time (JIT) delivered as the desired ‘matched product to end-user requirement.

Thus at Rio Tinto, sustainability, real-time predictive analytics, mine efficiencies, mine ventilation-on-demand, all autonomous/electric machinery, and JIT globally-connected remote-management control logistics networks, pervade all operational capabilities thinking. To optimally achieve these actions, Rio Tinto engage latest applicable creative technologies. They build internal capacities to help them successfully build and optimally mine. They continually innovate with specifically-skilled partners to improve everything they do. They use unique selections of resources smartly, efficiently and effectively. They up-skill their workforce to competently multi-task and interact with the virtual world. They engage their current and emergent intellectual properties and preserve their unique competencies as a foil against copy-cat rivals.

These all constitute a suite of essential competencies precursors required by Rio Tinto to support and help optimize their mining capabilities. These optimal operational capabilities are values driven, risks minimized, system connectivities networked, marketplace serving, and end-user consumer connected. As a suite of capabilities they network-combine and digitally integrate as a coalesced enhancement solution focused towards delivering a decarbonized, sustainable, intelligent, competitiveness that positions them strongly against their rivals.

Rio Tinto, like many firms, builds-up and enhances its competitiveness position over time, but Rio Tinto works diligently to remain a global leader in lowest-cost, ultra-efficient, high-tech mining. As per Figure 1, and across all five generations of AI, specificity and complexity of data deployed under successive generations of AI is helping Rio Tinto develop its digital competencies, better-action its capabilities, and focus towards being an even more competitive miner in the future.

Thus, where other leading-edge firms also choose to grow their leading-edge competitiveness, AI is likely an essential, and increasingly complex, business enabling component, requiring relevant ingredients from across all five of Figure 1’s AI generations. This alone requires advanced coding and extensive data capture and cloud storage. It is also likely that across a compact timeframe, leading-edge firms must strategically consider and deploy multiple AI generations together and also incorporate multiple platforms of IoE smart devices. This likely means they may need to understand more precisely how their business operates and delivers it ongoing AI competitiveness against rivals.

Ongoing firm competitiveness is a possible business outcome targeted position, derived through the skilful use of firm available, astutely-sourced and well-guarded, technological innovations and capacities. These competencies support the firm’s value adding actions, risks mitigations, and consumer and marketplace connectivities. These capabilities suites, along with their supporting competencies, present a useful network that can focus towards delivering an enhanced competitiveness position (Hamilton et al. (2020). Figure 3 offers a general competitiveness model structure specifically focused towards AI.

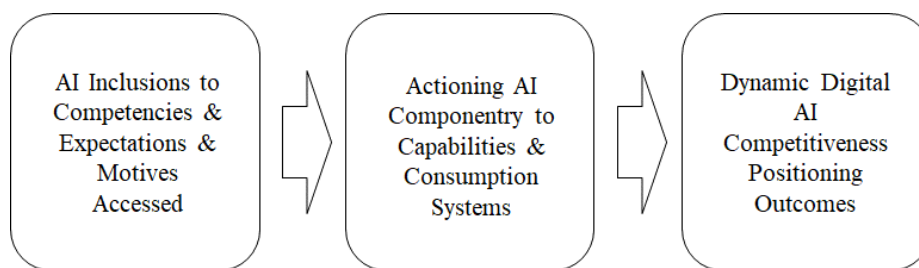

Source: This study & further model-adapted from Hamilton et al. (2023).

Figure 3: Strategic AI feedback model

Figure 3 also likely applies to smaller firms pursuing leading-edge approaches to AI. This study’s lead author is currently investigating Figure 3’s strategic AI feedback model separately and at three levels (global, industry, and firm). These differing firm-sized approaches are each structural equation modelling analysed. Results to date show a complex connectivities network solution does exist across these three stagewise AI development blocks.

## CONCLUSION

AI is not simple. AI is integrated into the firm to help achieve chosen strategies or targets. AI can be delivered across one or more of five generations of inclusion – from the first generation of least complexity through to the fifth generation of most complexity. AI across all generations continues to improve as machinery, devices, creative technologies, computing power and

innovation continue to improve. AI is a capabilities and functionalities strategic-build inclusion. It is likely best incorporated to help drive and enhance an overall competitiveness position.

Since 2006, Rio Tinto has remained on the mining technologies advancement pathway. Its achievements over time are substantive, productive, and leading-edge. It is now recognized as the most technologically advanced iron ore miner in the world (Chan, 2022), but it is not yet the most profitable global miner. Hence, it remains on positive competitiveness pathway against rivals.

AI competitiveness likely remains a digitally-related stagewise firm development. The leading-edge firm builds an AI mesh network that captures firm-wide technologies across multiple servers and seamlessly integrates them into a network of expectations, experiences and competitiveness outcomes.

First the leading-edge firm acquires a suite of necessary competitive business competencies. It supports each of the firm's leading-edge digital competencies with separate, specific, relevant AI inclusions which include integral, digital, enabler/learner/extender componentry.

Second, the leading-edge firm collectively enlists these AI-supported competencies as a combined suite of competitive digital enablers, specifically-focused towards innovatively optimizing/actioning each available key AI capabilities system into coalesced and measured AI-networked outcomes.

Third in an ongoing manner, the leading-edge firm then contributes its competencies and capabilities network towards enhancing its overall dynamic AI competitiveness positioning against rivals.

As a change driver, it is very likely AI can be successfully measured. Key areas of AI include machine learning, machine support vectoring, digital learning, deep learning, natural language processing, artificial neural networks, autonomous automation, machine visioning, and sensing. AI and its related data, can be captured, assessed, and adjusted for each AI application or inclusion. This useable information can be captured across Figure 3's stagewise strategic feedback model. Further, this approach also applies at generation 1 through to generation 5 applications, and either as single generation or multi-generation application system inclusion.

#### ACKNOWLEDGMENT

This work is partially built from assessment/research across Rio Tinto, its website, and its public-access downloadable reports.

#### REFERENCES

- Anon1. (2022). *Rio Tinto Annual Report 2022* (pp. 1-353). Rio Tinto Pub. Retrieved from <https://www.riotinto.com/en/invest/reports/annual-report> (accessed 10 August 2023).
- Anon2. (2022). *Rio Tinto Strategic Report 2022* (pp. 1-100). Australia: Rio Tinto Pub. Retrieved from <https://company-announcements.afr.com/asx/rio/9404c8e8-b2f7-11ed-8c64-2ed00a0d38ab.pdf> (accessed 11 August 2023).
- Anon3. (2022). *Rio Tinto Business Strategy 2022* (pp. 1-353). Rio Tinto Pub. Retrieved from <https://www.riotinto.com/en/about/business-strategy> (accessed 12 August 2023).
- Anon4. (2022). *Rio Tinto R&D and Technology* (pp. 1-353). Rio Tinto Pub. Retrieved from <https://www.riotinto.com/en/about/innovation/rd-and-technology> (accessed 12 August 2023).
- Anon5. (2022). *Rio Tinto Technology and Start-ups* (pp. 1-353). Rio Tinto Pub. Retrieved from <https://www.riotinto.com/en/about/innovation/tech-and-start-ups> (accessed 13 August 2023).
- Anon6 (2023). *Look Inside mine of the future*. Rio Tinto Pub. Retrieved from <https://www.riotinto.com/en/news/stories/look-inside-future-mine> (accessed 14 August 2023).
- Anon7. (2023). *10 stages of AI development*. Retrieved from <https://www.youtube.com/watch?v=AK5EwG62hx8> (accessed 1 Sept 2023).
- Anon8. (2023). *Unveiling the 10 Stages of AI: What You Need to Know NOW!* Retrieved from <https://www.youtube.com/watch?v=AK5EwG62hx8&t=4s> (accessed 20 Sept 2023).
- Bharadiya, J. P. (2023). *A Comparative Study of Business Intelligence and Artificial Intelligence with Big Data Analytics*. *American Journal of Artificial Intelligence*, 7(1), 24-30.
- Chan, R. (2023). *Rio Tinto's Gudai-Darri mine most technologically advanced in Pilbara*. *Australian Mining*. Retrieved from <https://www.australianmining.com.au/most-technologically-advanced-iron-ore-mine-in-pilbara> (accessed 15 August 2023).
- Hamilton, J.R., Ramanujam, R., Tee, S., & Underdown, M. (2020). *Business Competitiveness: Building and Applying the 3Cs and the Strategic Change Matrix across COVID-19*. *Global Journal of Science Frontier Research: I (Interdisciplinary)*, 20(5), 19-49.

- Hamilton, J.R., Tee, S., & Maxwell, S.J. (2023b). *AI and Firm Competitiveness*. In Li, E.Y. et al. (Eds.), *Proceedings of The International Conference on Electronic Business, Volume 23* (pp. 1.8). ICEB'23, Chiayi, Taiwan, October 17-23, 2023.
- Marr, D. (1976). *Artificial Intelligence - A personal view*. Massachusetts Institute of Technology Artificial Intelligence Laboratory, March(355), 1-11.
- Pallathadka, H., Ramirez-Asis, E. H., Loli-Poma, T. P., Kaliyaperumal, K., Ventayen, R. J. M., & Naved, M. (2023). *Applications of artificial intelligence in business management, e-commerce and finance*. *Materials Today: Proceedings*, 80, 2610-2613.
- Sestino, A., & De Mauro, A. (2022). *Leveraging artificial intelligence in business: Implications, applications and methods*. *Technology Analysis & Strategic Management*, 34(1), 16-29.
- Spence R. (2014). *Rio Tinto: Mine of the Future*. *Mining Digital Magazine*, 10-15. Retrieved from <https://miningdigital.com/supply-chain-and-operations/rio-tinto-mine-future> (accessed 4 August 2023).
- Zohuri, B., & Moghaddam, M. (2020). *From business intelligence to artificial intelligence*. *Journal of Material Sciences & Manufacturing Research*, 1(1), 1-10.

## **Be Human-Like or AI-Like: Investigating the Impact of the Anthropomorphism and Decision Valence on Organizational Justice and Attractiveness in the AI-Recruitment**

Donghwan Kwon <sup>1</sup>  
Jooyoung Kim <sup>2</sup>  
Sunyoung Choi <sup>3</sup>  
Yechan Kim <sup>4</sup>  
Hangjung Zo <sup>5,\*</sup>

\*Corresponding author

<sup>1</sup> Master's Student, School of Business and Technology Management, College of Business, Korea Advanced Institute of Science and Technology, Daejeon, Republic of Korea, dh\_kwon@kaist.ac.kr

<sup>2</sup> Doctoral Student, School of Business and Technology Management, College of Business, Korea Advanced Institute of Science and Technology, Daejeon, Republic of Korea, jyk1095@kaist.ac.kr

<sup>3</sup> Doctoral Student, School of Business and Technology Management, College of Business, Korea Advanced Institute of Science and Technology, Daejeon, Republic of Korea, sunyung97@kaist.ac.kr

<sup>4</sup> Master's Student, School of Business and Technology Management, College of Business, Korea Advanced Institute of Science and Technology, Daejeon, Republic of Korea, yc1189@kaist.ac.kr

<sup>5</sup> Professor, School of Business and Technology Management, College of Business, Korea Advanced Institute of Science and Technology, Daejeon, Republic of Korea, joezo@kaist.edu

### **ABSTRACT**

The advancement of technology has led to the diffusion of AI, extending beyond individuals to the organizational level. Among all, AI recruitment is increasing organizations' interest in its adoption to enhance operational efficiency, shape an attractive corporate image, and elevate the recruitment experience.

However, despite the increasing importance of AI recruitment, most of the previous research is conducted in the context of AI versus Human or AI-human collaboration and there is a lack of research examining how the applicant's perceptions of organizational justice and attractiveness are formed by the AI recruiter's human-likeness and situational context.

To address this research gap, this study aims to investigate the impact of AI Anthropomorphism on procedural justice, interactional justice, and organizational attractiveness based on the positive/negative outcome in an AI Recruitment setting. This study conducted a scenario-based between-subject experiment involving a 2(Human-like/Machine-like)X2(Positive/Negative) design. An independent sample T-test and ANOVA were conducted to test the hypotheses.

The results revealed that people prefer Human-like AI recruiters to machine-like ones in all measured variables. Considering the recruitment's valence, there were significant differences in perceived interactional Justice and organizational attractiveness only in the negative decision-making situations. However, procedural justice did not differ based on the level of AI anthropomorphism. It showed an outcome bias, which shows that regardless of the AI recruiter's type, applicants tend to perceive higher procedural justice in positive rather than negative situations. This research offers insights for developers of AI Recruitment solutions and organizations considering the adoption of AI Recruitments, helping them explore optimal strategies for utilizing AI Recruitment system effectively.

*Keywords:* AI recruitment, Human-like AI, Organizational attractiveness, Procedural and Interactional justice, Outcome bias

### **INTRODUCTION**

AI-based Human Resource Management (HRM) has emerged as a new trend, leveraging big data and AI technology to enhance efficiency in HRM (Hmoud & Várallyai, 2020; Statista, 2020). The COVID-19 pandemic has accelerated the adoption of technology-driven HRM solutions, especially in exploring remote work methods (Maurer, 2020). According to the global market research firm 'Research and Market,' the AI HR market worldwide is predicted to achieve an average annual CAGR of 35.26%, growing from 3.89 billion in 2022 to 17.61 billion in 2027 (Researchandmarket, 2023). Thus, the introduction of AI in the field of HRM has become indispensable in this era.

Among various value chains in HRM AI service, In light of the increasing significance of talent acquisition for organizations, there has been a growing interest and effort among companies to introduce AI into their recruiting systems to ensure efficiency and fairness (Van Esch, Black, & Ferolie, 2019; Lee & Kim, 2021). AI-Recruitment can be defined as the utilization of AI with

the aim of assisting organizations in their recruitment processes (Hunkenschroer & Luetge, 2022). It encompasses a wide range of the recruitment process, ranging from outreaching potential candidates, screening resumes, analyzing and evaluating recruitment, to the necessary coordination leading to final hiring decisions, thus demonstrating a broad potential for extensive application across a company's overall recruitment functions (Black & van Esch, 2020; Lee & Kim, 2021). AI Recruitments not only enhance operational efficiency (Miller, Katz, & Gans, 2018) but also play a significant role in shaping a company's initial impression (Mirowska & Mesnet, 2022). Despite the considerable market potential of AI Recruitments, there are challenges to address during market expansion, including the potential for negative recruitment experiences compared to human interactions such as procedural fairness in decision-making (Konradt et al., 2020) and dehumanization concerns, where applicants are treated as data points rather than individuals deserving respect and value (Stone et al., 2015; Wang, Min, & Liu, 2021).

On the other hand, Recent advancements in generative AI technology have led to the emergence of highly sophisticated human-like AI, to the extent that it has become difficult to distinguish from real humans (Franke, Groeppel-Klein, & Müller, 2023), making them expected to bring innovative changes to various industries (Budhwar et al., 2023). While previous studies have explored the impact of Human-like AI on customers in various service domains such as retail (Jiang, Qin, & Li, 2022), banking (Lee & Chen, 2022), hospitality (Fan et al., 2020), and healthcare (Sestino & D'Angelo, 2023), limited research exists on the effects of anthropomorphism in the crucial context of AI recruitments. Additionally, previous studies have primarily focused on identifying variables affecting technology acceptance, comparing human and AI preferences, and examining consumer perceptions of human-AI collaboration. However, limited research compares consumer perceptions based on AI product characteristics. Specifically, there is a lack of studies comparing consumer perceptions in different levels of Humanizing the AI product (Mirowska & Mesnet, 2022) and situational contexts, such as positive/negative decision-making (Pan et al., 2022).

Therefore, this study examines the effect of the AI recruiter's type and decision valence on the recruiter's perception of organizational justice and attractiveness. This study aims to focus on the following two key research questions: 1) "How do different level of Anthropomorphism, which is shown as AI recruiter types affect applicants' perceptions of organizational fairness and attractiveness?", 2) "Do applicants' perceptions of AI recruiters change based on feedback received during the recruitment process?"

To examine these research questions, this study conducts the 2 (Level of Anthropomorphism: Human-like/Machine-like) X 2 (decision-making valence: negative/positive) between-subject experiment. To enhance the external validity of the research, we provide the mock AI Recruitment through the AI Recruitment scenarios, and each group's participants allocate to complete the questionnaire regarding the perceptions of justice and organizational attractiveness.

This study provides implications for companies' practical AI adoption by verifying how the degree of AI anthropomorphism, especially, Human-like AI recruiter affects the company's recruitment experience in line with the advancing AI recruitment trend. Furthermore, it demonstrates the importance of providing appropriate AI Recruitment experiences according to the positive/negative decision-making context to identify the boundary condition for this effect.

## **THEORETICAL BACKGROUND AND HYPOTHESES**

### **CASA Theory and Human-like AI**

Technological progress is leading innovation in various key service sectors by enhancing AI to be more human-like and providing customers with new experiences (Li & Suh, 2022; Li & Sung, 2021). The growing desire to develop AI that increasingly resembles humans can be explained through the CASA theory. According to the CASA theory, people tend to perceive the process of interacting with computers similarly to human-to-human interaction (Reeves & Nass, 1996). The CASA theory suggests that people unconsciously apply social norms and attitudes they hold towards humans even when interacting with AI (Mou & Xu, 2017). Furthermore, it has been proposed that if AI displays social and human-like cues, these effects can be amplified (Nass & Moon, 2000).

Previous studies have presented various criteria for attributing human features to AI service agents. Yang et al. (2022) suggested human features to include psychological features such as emotions, and non-psychological features such as appearance, and human-like capabilities like empathy. Baek and Kim (2023) further categorized them into visual cues like human faces and body parts, as well as verbal cues such as human names. However, these elements are not always clearly distinguishable, and are often integrated and recognized as giving consumers the impression that they possess human characteristics.

In various service domains, humanized AI has been recognized as a strategic approach that can lead to positive consumer responses and contribute to business success. It surpasses general AI by forming higher performance expectations similar to humans (Bickmore & Picard, 2005; Qiu et al., 2020), increasing the perception of social presence, enhancing trust (Qiu & Benbasat, 2009), and encouraging service adoption and continued use (Han & Yang, 2018; Li & Suh, 2021).

However, previous research has also indicated that humanized AI can be negatively perceived in specific situations or contexts. For example, the Uncanny Valley effect, where individuals feel confusion and fear about human identity when observing the appearance of humanized AI (Ciechanowski et al., 2019), or situations where expectations of high-level service from humanized AI do not align with reality (expectancy violation) can lead to negative consumer reactions (Sheehan, Jin, & Gottlieb, 2020; Crolig et al., 2022). Moreover, exceptions exist, where less humanized AI can be positively perceived, particularly in analytical and objective tasks or interactions that require personal information disclosure (Lucas et al., 2014; Lee, 2018).

Despite extensive research on consumer responses to AI across various service domains, there has been limited exploration of the human-like versus machine-like dimension in the context of AI Recruitments. Previous studies have mostly focused on AI versus human comparisons (Bankins et al., 2022; Schlicker et al., 2021) or AI-human collaboration contexts (Jiang et al., 2023; Gonzalez et al., 2022). Therefore, this study aims to investigate how Human-like AI and Machine-like AI influence perceived fairness and attitudes towards the company in the context of recruitments.

### **AI Recruitment and Organizational Justice**

In the context of company's recruitment process, applicants have limited opportunities to interact with the company; therefore, the recruiting process itself can have a greater impact on forming perceptions and attitudes toward the company, rather than objectively stated company and job characteristics (Harris & Fink, 1987; Walker et al., 2015). In particular, applicants form justice expectations during the recruitment process (Gilliland, 1993), which not only motivates their continued participation in the recruitment process but also influences their attractiveness to the organization and their decision to ultimately accept the job offer (Bell, Wiechmann, & Ryan, 2006; Newman, Fast, & Harmon, 2020).

These justice expectations have been evolving based on Organizational Justice theory and can be classified into Distributive Justice (focusing on fairly allocation outcomes) (Adams, 1965), Procedural Justice (emphasizing the fairness of procedural processes leading to outcomes) (Leventhal, 1980), and Interactional Justice (centered on interpersonal interactions during decision-making processes) (Bies & Moag, 1986) (Colquitt, Greenberg, & Zapata-Phelan, 2013). Among these, this study intends to explore applicant reactions in the context of AI Recruitments, considering AI's requirement for objectivity in procedural justice and its demand for human-likeness interaction in interactional justice.

First, from the perspective of procedural justice, previous research on AI versus Human in the context of Schlicker et al. (2021) examined justice perceptions in health-care scheduling. The results indicated that applicants perceived human agents as more favorable in terms of interactional aspects and preferred automated agents in terms of the objectivity of decision-making. Next, Noble, Foster, and Craig (2021) investigated procedural and interpersonal justice perceptions in the context of automated application and resume screening. The results showed that most people perceived algorithm-based screening as negative compared to traditional human approaches. However, in terms of the procedural justice aspect of consistency, algorithm-based screening was perceived more positively.

In this way, the characteristic of AI being consistent and capable of objective evaluation (Lee, 2018; Araujo et al., 2020; Loureiro, Guerreiro, & Tussyadiah, 2021) leads us to expect that, according to the CASA theory, Machine-like AI will be perceived as more 'AI-like' compared to Human-like AI, thereby enhancing the perceived procedural fairness in the recruitment process. Based on this, we propose the following hypothesis:

*H1: Perceived procedural justice will be higher with the Machine-like AI recruiter than with a Human-like AI recruiter.*

Next, Interactional Justice is considered to be more crucial and perceived as a complement that should be given more consideration in the context of AI Recruitments compared to traditional human recruitment methods (Gonzalez et al., 2019). Most previous research conducted in the AI versus Human context, mainly involving AI recruiters, has revealed that recruitments conducted by AI recruiters are perceived more negatively in terms of Interactional Justice compared to recruitments conducted by human recruiters.

Bankins et al. (2022) conducted a study comparing applicant responses to AI versus Human decision makers in the context of HRM. The study found that participants generally felt a higher perception of respectful treatment in scenarios where the recruitment was conducted by a human decision maker compared to an AI decision maker. Additionally, Acikgoz et al. (2020) aimed to compare applicants' Perceived Justice between AI and Human recruitments based on AI Recruitment scenarios. The results confirmed that people perceived AI-based recruiting as less interactionally justified compared to traditional human-based recruitments.

In line with the CASA theory, this study expects that Human-like AI will be perceived as more human-like relative to Machine-like AI, leading to the anticipation that, consistent with the findings from previous research, Human-like AI will exhibit higher levels of Interactional Justice compared to Machine-like AI.

*H2: Perceived interactional justice will be higher with the Human-like AI recruiter than with a machine-like AI recruiter.*

### **AI Recruitment and Organizational Attractiveness**

With the advancement of generative AI technology, humanized AI is expected to create new value not only in the traditional areas of customer service and interaction, which AI agents have been performing, but also in new areas such as education instructors and advertising models. This study aims to investigate the impact of humanized AI, facilitated by generative AI technology, on the attitude toward a company when it replaces humans in the context of AI Recruitments.

Organizational attractiveness can be defined as a general attitude toward how people perceive an organization from the perspective of a potential workplace (Smith, Bolton, & Wagner, 1999; Wilhelmy et al., 2019). AI Recruitments are still considered an emerging technology, and given the asymmetry of information in this domain, the AI Recruitment experience

provided by a company can serve as a signal and a first impression of how applicants perceive the organization (Gonzalez et al., 2022). This can shape applicants' attitudes toward the company and potentially influence recruitment and selection outcomes (Chapman et al., 2005).

Various previous studies argue that the adoption of AI technology can help generate positive attitudes toward companies among consumers (Franke, Groeppel-Klein, & Müller, 2023; Folger et al., 2021). Franke, Groeppel-Klein, and Müller (2023) aimed to examine consumer responses by comparing Virtual Humans created using generative AI technology as corporate advertising models with Human influencers. The study found that people tend to prefer Human influencers, but when using Virtual Human endorsers, it can increase Perceived ad novelty for the company. This effect was particularly pronounced when advertising products (such as digital devices) with a high perceived congruence between the product and the Virtual Influencer. Folger et al. (2021) investigated whether the extent to which companies use digital selection methods in their hiring processes mediates changes in user perceptions of innovativeness toward organization and employer attractiveness. The results showed that participants perceived organizations as more innovative when digital selection methods were high, leading to increased employer attractiveness.

Building on previous research, this study also expects that introducing Human-like AI recruiters in the context of AI Recruitments is likely to be perceived by applicants as the adoption of more advanced technology compared to Machine-like AI. This, in turn, is expected to contribute to forming a positive attitude towards the company.

*H3: Perceived organizational attractiveness will be higher with the Human-like AI interviewer than with a machine-like AI interviewer.*

### **Decision Valence and Outcome Bias**

According to previous research, consumer responses to AI can differ depending on the Valence (Positive versus Negative) context (Garvey, Kim, & Duhachek, 2023; Bankins et al., 2022). Garvey, Kim, and Duhachek (2023) suggested that in a positive service offer context, consumers tend to respond more favorably to humans than AI. However, in negative situations, AI interactions may result in better outcomes in terms of purchase likelihood and satisfaction compared to human interactions. Garvey, Kim, and Duhachek (2023) argued that this phenomenon might be due to the perception that AI is less likely to have malicious intent when proposing negative deals. On the contrary, Bankins et al. (2022) found a tendency for participants to prefer humans over AI in both positive and negative decision-making scenarios during AI Recruitments. Therefore, if negative results are conveyed by AI, it may lead to a more negative recruitment experience for consumers.

However, research on the impact of Decision Valence on consumer responses in the context of Human-like AI versus Machine-like AI is currently lacking. Until now, studies have focused on Human versus AI contexts, leaving a gap in understanding how Decision Valence might affect consumer reactions when comparing Human-like AI and Machine-like AI recruiters. Thus, this study plans to investigate how responses to Valence differ depending on the type of AI recruiter (Human-like AI versus Machine-like AI) in the unique context of AI Recruitments.

In particular, this study aims to draw attention to a specific phenomenon known as 'Outcome bias', which may arise due to the introduction of new technology like AI Recruitments, as per Signaling theory (Chapman, Uggerslev, & Webster, 2003). Outcome bias occurs when individuals evaluate decisions with positive outcomes more favorably and decisions with negative outcomes more negatively, regardless of the decision's quality or the attributes or processes involved in decision-making (Fischhoff, 1975; Lipshitz, 1989). Previous research suggests that Outcome bias is amplified when individuals have little relevant information to base their evaluations of decisions (Baron & Hershey, 1988; Strohmaier et al., 2021).

Even if the form of AI recruiters becomes more advanced, users are likely to perceive uncertainty about decision information in AI Recruitment contexts unless information about AI Recruitment decision outcomes or processes is provided. Therefore, this study anticipates that Outcome bias will occur in AI Recruitment contexts regardless of the type of AI recruiter and presents the following hypothesis:

*H4-a: Regardless of the AI recruiter's type, Perceived procedural justice will be higher in positive decision-making situation rather than the negative decision-making situation.*

*H4-b: Regardless of the AI recruiter 's type, Perceived interactional justice will be higher in positive decision-making situation rather than the negative decision-making situation.*

*H4-c: Regardless of the AI recruiter 's type, Perceived organizational attractiveness will be higher in positive decision-making situation rather than the negative decision-making situation.*

## **METHODOLOGY**

### **Research Design**

In this study, a scenario-based experimental study was conducted to investigate the effects of anthropomorphism and decision valence on user perception and response in an AI Recruitment context. The experiment included two factors: Level of AI anthropomorphism (AI recruiter type: Human-like AI/Machine-like AI) and Valence (Recruitment results: Positive/Negative), resulting in a 2x2 design.



To manipulate the level of anthropomorphism, the participants were divided into two groups: the high group, where the AI recruiter was designed to be more human-like, and the low group, where the AI recruiter was designed to be more machine-like. An avatar of the AI recruiter was created using a generative AI video production tool called “SYNTHESIA”.

This study aimed to incorporate AI humanization technology that can be currently implemented into the research scenario to the fullest extent, with a focus on the humanization of external elements. In the case of Human-like AI, sub-elements of external humanization, such as facial expression, human appearance, and name, were assigned, while other aspects such as language style, speech content, voice tone, and gestures were all controlled.

For the manipulation check, an Independent-sample t-test was conducted to check whether there was a significant difference in the Perceived Anthropomorphism variable between the Human-like and Machine-like groups. Perceived Anthropomorphism (AP) was measured using a scale adapted from Bartneck's (2009) study. The scale consisted of a total of three items. Specifically, each survey item is as follows: AP1 (AI recruiter is more human-like); AP2 (AI recruiter is conscious of their actions); AP3 (AI recruiter is lifelike and not artificial).

According to the result of the independent-sample t-test, there was a significant difference in the Perceived Anthropomorphism variable between the AI recruiter types, with a t-value of 8.048. When comparing the difference in means, the Human-like AI group ( $M=3.72$ ) exhibited a higher level of Perceived Anthropomorphism than the Machine-like AI group ( $M=2.34$ ) ( $P=.000$ ). Therefore, it was confirmed that there were no issues with the AI recruiter type settings for the experiment.

Furthermore, the decision valence was divided into Positive and Negative conditions. In the Positive condition, the AI recruiter delivered the result, "You have successfully passed this recruitment stage," indicating a favorable outcome. On the other hand, in the Negative condition, the experimental situation was designed so that the AI recruiter stated, "You have unfortunately failed this recruitment stage," indicating an unfavorable outcome.

To enhance the validity of the study, a scenario was created based on prior research related to AI Recruitments. The AI recruitment scenario used in the study is as follows:

“Imagine you have just applied for your dream job at Company ‘A’. You've been eagerly waiting for a response, and finally, you receive an email informing you that your application has been accepted. The next step in the hiring process is a video recruitment conducted by an advanced AI recruiter through your webcam. According to the information, the AI recruiter of company ‘A’ was developed in compliance with company A's HR guidelines, which were learned based on discussions by representatives of the HR department, and its performance has been improved by utilizing several years' worth of recruitment recruitment data. The recruitment process will be led by an AI recruiter. The AI recruiter asks you structured recruitment questions and scores your answers with the criteria of the content, verbal, and non-verbal responses through an advanced artificial intelligence-based algorithm. After the recruitment, based on your answers, artificial intelligence will automatically determine if you are the right person to move on to the next recruitment and inform you of the results. Over time, the scheduled AI Recruitment day arrived. You access the link provided in the email and proceeded to conduct an AI Recruitment. Please participate in the recruitment as if it is a real job recruitment.”

As such, the participants in the experiment engaged in a virtual recruitment scenario, where they were assigned to one of the randomly selected conditions among the 2 X 2 groups. In the virtual recruitment, participants imagine as if they were in a real recruitment, watch a video with a written scenario and an AI recruiter, and answer one recruitment question (“Please explain the most important factors that you consider when selecting the company and explain why”). When the participant submits the answer, a screen appears as if AI is analyzing the results. After a while, the AI recruiter will randomly announce to the recruitment participants the results of passing or failing the recruitment. After the scenario is finished, the experiment participants proceed with questionnaires on various variables based on the mock AI Recruitment experience.

To address additional research questions and test hypotheses, several research variables were measured, including Perceived Interactional Justice, Perceived Procedural Justice, Organizational Attractiveness, and various control variables.

### Measurement Scales

The scale for measuring the research variables and control variables in the survey was selected based on previous studies. As research variables, Interactional Justice, Procedural Justice, and Organizational Attractiveness were collected, and demographic variables (age, gender, education, Employment status, Work experience, and Prior AI-based recruitment experience) were measured as control variables. Scales of all study variables were measured with a 7-point Likert scale (1 = Strongly Disagree, 7 = Strongly Agree).

Perceived Procedural Justice (PJ) was measured by adapting the scale used in Colquitt's (2001) study to match the context of this study, and consisted of a total of three items. Specifically, each survey item is as follows: PJ1 (I feel that AI Recruitment procedure would be in a consistent manner); PJ2 (I feel that AI Recruitment procedure was free of bias) and PJ3 (I feel that AI Recruitment procedure was based on accurate information).

Perceived Interactional Justice (IJ) was measured by changing the scale used in the study by Chi, Wen, and Ouyang (2020) to match the context of this study and consisted of a total of three items. Specifically, the questionnaire items are as follows: IJ1 (I feel like that AI recruiter respected me); IJ2 (I feel like that AI recruiter was very polite) and IJ3 (I feel like that AI recruiter served me with great enthusiasm)

Organizational Attractiveness (OA) was assessed by adapting the scale used in the study by Highhouse, Lievens, and Sinar (2003) to fit the context of the current study and consisted of a total of three items. Specifically, the questionnaire items are as follows: OA1 (For me, the company which conducted the AI Recruitment in this scenario would be a good place to work); OA2 (The company which conducted the AI Recruitment in this scenario was attractive to me as a place for employment) and OA3 (Getting a job of the company in the scenario is very appealing to me).

## RESULTS

### Demographic Statistics

The survey data was collected from a total of 321 individuals using a research platform named “Cloud Research”. From the collected 321 survey respondents, a total of 296 responses were analyzed after excluding samples with straight-lining answers and those corresponding to the “Retired” employee status. General demographic attributes such as Gender, Age, and Education, as well as employment-related attributes including Employee status, Work experience, and Prior AI-interview, which could influence the analysis, were collected.

Table 1: Respondents’ demographic Characteristic

Characteristics of respondents		Frequency (N=296)	Percentages	Characteristics of respondents		Frequency (N=296)	Percentages	
Gender	Male	147	49.7	Employee status	Full-time	179	60.5	
	Female	149	50.3		Part-time	53	17.9	
Age	18-24	43	14.5	Employee status	Currently Seeking opportunities	53	17.9	
	25-29	50	16.9		Work experience	Prefer not to say	11	3.7
	30-34	63	21.3			Fewer than 1year	32	10.8
	35-39	43	14.5			More than 1year to fewer than 3years	33	11.1
	40-44	37	12.5	More than 3years to fewer than 5years		31	10.5	
	45-49	19	6.4	More than 5years to fewer than 10years		59	19.9	
	50-54	15	5.1	More than 10years	141	47.6		
	55-59	14	4.7	Prior AI-recruitment experience	Yes	11	3.7	
	Above 60	12	4.1		No	285	96.3	
Education	Some high school or less	5	1.7					
	High school	109	36.8					
	Bachelor’s Degree	149	50.3					
	Master’s Degree	30	10.1					
	Ph.D or higher	4	1.0					

Source: This study.

The characteristics of the survey respondents who participated in this study are presented in <Table 1>. Among them, 147 respondents (49.7%) were male, and 149 respondents (50.3%) were female. Employee status revealed that a total of 232 individuals (78.4%) were currently employed, including both full-time and part-time positions. Respondents in the “Currently seeking opportunities” category, which is closely related to job interviews, accounted for 53 participants (17.9%). Only 11 individuals (3.7%) had actual experience participating in an AI interview, indicating a limited presence of real AI recruitment experiences among the majority of the respondents.

### Reliability and Validity Testing of Measurement Items

Prior to hypothesis testing, exploratory factor analysis and reliability analysis were conducted to confirm the validity and reliability of the measurement items. The results of the analyses are presented in <Table 2>. First, exploratory factor analysis was performed to assess the suitability of factor analysis using the Kaiser-Meyer-Olkin (KMO) measure of sampling adequacy and Bartlett's test of sphericity. The analysis results revealed a KMO value of 0.6 or higher and a significant p-value (<0.001) for Bartlett's test, indicating the appropriateness of factor analysis. Next, reliability analysis was conducted to measure the internal consistency of the items, using Cronbach's alpha coefficient. All values exceeded 0.5, demonstrating satisfactory consistency.

Table 2: Result of Exploratory Factor Analysis

Kaiser-Meyer-Olkin Measure of Sampling Adequacy	0.894	
Bartlett's Test of Sphericity	Approx. Chi-Squar	3000.306
	df	66
	p	.000***

\*p<.05, \*\*p<.01, \*\*\*p<.001

Factor		Factor Analysis				Credibility
Components		Factor loading	Extraction	Rotation sums of squared loading		Cronbach alpha
				Total	% of variance	
Anthropomorphism1	AI recruiter in this scenario was more human-like	0.891	0.846	2.593	21.611	0.553
Anthropomorphism2	AI recruiter in this scenario seems conscious of its actions	0.794	0.759			0.627
Anthropomorphism3	AI recruiter in this scenario feel lifelike and not artificial	0.893	0.901			0.657
Procedural_Justice1	AI Recruitment procedure would be in a consistent manner	0.811	0.816	2.498	20.818	0.693
Procedural_Justice2	AI Recruitment procedure was free of bias	0.812	0.827			0.683
Procedural_Justice3	AI Recruitment procedure was based on accurate information	0.793	0.835			0.735

Interactional_Justice1	AI recruiter in this scenario respected me	0.738	0.768	2.235	18.627	0.705
Interactional_Justice2	AI recruiter in this scenario was very polite	0.811	0.792			0.604
Interactional_Justice3	AI recruiter in this scenario was more human-like	0.718	0.728			0.681
Organizational_Attractiveness_1	The company in this scenario would be a good place to work	0.822	0.923	2.723	22.692	0.817
Organizational_Attractiveness_2	The company in this scenario was attractive to me as a place for employment	0.861	0.927			0.781
Organizational_Attractiveness_3	Getting a job at the company in this scenario is very appealing to me	0.849	0.927			0.797

Source: This study.

### Analysis of Differences in Measured Variables

#### Mean, Standard Deviation, and Correlation of Measured Variables

Prior to conducting the Independent Samples T-test and analysis of variance (ANOVA), the means, standard deviations, and correlations of the measurement variables, namely Procedural Justice, Interactional Justice, and Organizational Justice, were examined. The analysis results are presented in <Table 3>, providing an overview of the means, standard deviations, and correlations among these variables.

Table 3: Mean, Standard Deviations, and Correlations among the variables

	M	SD	PJ	IJ	OA
Procedural_Justice (PJ)	4.395	1.508	-	0.672**	0.653**
Interactional_Justice (IJ)	4.496	1.321	0.672**	-	0.648**
Organizational_Attractiveness (OA)	3.830	1.741	0.653**	0.648**	-

Source: This study.

#### Hypothesis Testing through Independent Samples T-test

An independent-sample t-test was conducted to determine if there were any difference in the mean scores of the measurement variables (procedural Justice, Interactional Justice and Organizational Attractiveness) across different AI interviewer type.

Before conducting the t-test, a preliminary analysis was performed to assess whether the basic assumptions of the t-test, namely normality and homogeneity of variance, were met. First, regarding the normality assumption, as shown in <Table4>, the data were found to be normally distributed for each group. This was evident from skewness and kurtosis values that were less than |2.0| and |9.0|, respectively, in line with guidelines from Schmider et al. (2010).

Next, to assess the homogeneity of variance assumption, Levene's F test was conducted. The results indicated that all assumptions of equal variances were satisfied for the following variables: Procedural Justice (F=0.745, p=0.389), Interactional Justice (F=3.670, p=0.056), and Organizational Attractiveness (F=1.220, p=0.270).

Table 4: Descriptive statistics for research variables

Variables	<i>n</i>	<i>M</i>	<i>SD</i>	<i>Skewness</i>	<i>Kurtosis</i>
Procedural Justice	296	4.395	1.509	-0.399	-0.575
Interactional Justice	296	4.497	1.321	-0.317	-0.126
Organizational Attractiveness	296	3.830	1.741	-0.066	-1.071

Notes: n= number of participants; M=mean; SD=Standard Deviation

Source: This study.

The results of the independent-sample t-tests are presented in <Table5>. For Procedural Justice, the t-value was 2.017, indicating a significant difference between AI interview types. When comparing the mean differences, the Human-like AI group (M=4.569) scored higher in Procedural Justice compared to the Machine-like AI group (M=4.217) (p=0.045). Therefore, H1 was rejected.

Second, for Interactional Justice, the t-value was 3.203, indicating a significant difference between AI interview types. When comparing the mean differences, the Human-like AI group (M=4.736) scored higher in Interactional Justice compared to the Machine-like AI group (M=4.251) (p=0.002). Therefore, H2 was supported.

Lastly, for Organizational Attractiveness, the t-value was 2.850, indicating a significant difference between AI interview types. When comparing the mean differences, the Human-like AI group (M=4.111) scored higher in Organizational Attractiveness compared to the Machine-like AI group (M=3.541) (p=0.005). Therefore, H3 was supported.

Table 5: Independent-Sample t-Tests for Mean Differences in Measured Variables Based on AI Interviewer Type

Variables	Group	<i>N</i>	<i>M</i>	<i>SD</i>	<i>t</i>	<i>p</i>
Procedural Justice	Human-like	150	4.569	1.468	2.017	0.045
	Machine-like	146	4.217	1.534		
Interactional Justice	Human-like	150	4.736	1.184	3.203	0.002
	Machine-like	146	4.251	1.411		
Organizational Attractiveness	Human-like	150	4.111	1.697	2.850	0.005
	Machine-like	146	3.541	1.744		

Notes: n= number of participants; M=mean; SD=Standard Deviation

Source: This study.

#### Hypothesis Testing through One-Way Analysis of Variance (ANOVA)

To investigate whether there were differences in the mean scores of the measurement variables (Procedural Justice, Interactional Justice, Organizational Justice) across different AI interview situations, a one-way analysis of variance (ANOVA) was conducted. The research findings are presented in <Table 6>, which provides an overview of the results.

Table 6: Difference Testing of Dependent Variables across AI Interview Scenarios

Treatment_Group		Procedural Justice					
		n	Mean	Std. Dev	F	p	Bonferroni
AI Interview	Human-like/Positive(a)	74	5.180	1.238	18.887	0.000***	a>b, a>d,

Case	Human-like/Negative(b)	76	3.974	1.436		c>b, c>d
	Machine-like/Positive(c)	77	4.745	1.401		
	Machine-like/Negative(d)	69	3.628	1.469		

\*p<.05, \*\*p<.01, \*\*\*p<.001

Source: This study.

Treatment_Group	Interactional Justice					
	n	Mean	Std. Dev	F	p	Bonferroni
	Human-like/Positive(a)	74	5.063	1.115		
AI Interview Case	Human-like/Negative(b)	76	4.417	1.130	17.112	0.000*** a>b, a<d, b>d, c>d
	Machine-like/Positive(c)	77	4.771	1.261		
	Machine-like/Negative(d)	69	3.672	1.349		

\*p<.05, \*\*p<.01, \*\*\*p<.001

Source: This study.

Treatment_Group	Organizational Justice					
	n	Mean	Std. Dev	F	p	Bonferroni
	Human-like/Positive(a)	74	4.487	1.679		
AI Interview Case	Human-like/Negative(b)	76	3.746	1.644	12.176	0.000*** a>b, a>d, b>d, c>d
	Machine-like/Positive(c)	77	4.121	1.745		
	Machine-like/Negative(d)	69	2.894	1.509		

\*p<.05, \*\*p<.01, \*\*\*p<.001

Source: This study.

Based on the results presented in <Table 6>, significant differences were found among the AI Recruitment cases in terms of the mean scores of Procedural Justice (F=18.887, p=.000), Interactional Justice (F=17.112, p=.000), and Organizational Attractiveness (F=12.176, p=.000). To further examine the specific differences between groups, post hoc tests using the Bonferroni test were conducted.

For Procedural Justice, the results indicate that in the case of Machine-like AI recruiters presenting Positive Valence, participants rated Procedural Justice 0.771 points higher on average compared to the situation where Human-like AI recruiters presented Negative Valence (p=0.004), thereby supporting hypothesis H4-a. This shows the phenomenon called 'Outcome bias' which shows that the situational context of Valence has a greater influence on participants' perception of Procedural Justice than the type of AI recruiter.

Regarding Interactional Justice, it was found that the AI recruiter type only showed significant differences when the AI Recruitment results were negative. In such cases, Human-like AI recruiters were associated with higher scores in Interactional Justice (0.7452 points higher,  $p=0.002$ ) than Machine-like AI recruiters. However, no significant differences were found in Interactional Justice when comparing Positive Valence situations with Machine-like AI recruiters to Negative Valence situations with Human-like AI recruiters, leading to the rejection of hypothesis H4-b.

Organizational Attractiveness is the last variable to be examined. The results indicate that there were significant differences in the participants' perceptions of Organizational Attractiveness based on the form of AI recruiters, but only when the AI Recruitment results were negative. Human-like AI recruiters were rated on average 0.8519 points higher than Machine-like AI recruiters ( $p=0.000$ ). This finding is consistent with the results for Interactional Justice, suggesting that in decision-making situations that may evoke Negative Valence, utilizing Human-like AI recruiters can be more effective in terms of Interactional Justice and Organizational Attractiveness. However, similar to Interactional Justice, no significant differences were found in Organizational Attractiveness when comparing Positive Valence situations with Machine-like AI recruiters to Negative Valence situations with Human-like AI recruiters, leading to the rejection of hypothesis H4-c.

## CONCLUSION

### Discussion

The increasing utilization of AI in corporate recruitment extends beyond enhancing organizational efficiency to encompass promoting the company's image. As a result, the significance of and the interest in implementing AI-based recruitments have grown. In line with this industry trend, this study aims to propose effective strategies for implementing AI Recruitments by examining the impact of the AI recruiter's type (Human-like/Machine-like) and the nature of recruitment outcomes (Positive/Negative) on applicants' perceptions of organizational fairness and attractiveness.

The research findings indicate that when the AI recruiter takes on a Human-like form, users responded significantly more positively in terms of interactional Justice and organizational attractiveness compared to when it had a Machine-like appearance. These findings are aligned with prior research findings indicating that humanized AI, perceived as similar to humans, can elicit positive customer responses through high performance expectancy and social presence (Qiu et al., 2020; Xie et al., 2023). However, contrary to the hypothesis that machine-like AI would be perceived as higher procedural justice due to its greater objectivity, it was found that procedural justice was perceived as higher in the case of human-like AI compared to machine-like AI. These results can be interpreted as applicant perceiving AI recruitment as inherently high in consistency, regardless of its recruiter type, due to the inclusion of AI in its functionality. Hence, applicants tend to perceive Human-like AI, with its inclusion of machine heuristic attributes, as having an overall higher performance expectancy.

In the contexts where decision valence is considered, the AI recruiter's form only exhibited significant differences in Interactional Justice and Organizational Justice when conveying negative recruitment outcomes. This suggests that anthropomorphizing AI recruiters could be an effective solution for enhancing perceptions of fairness and attractiveness in AI-based recruiting recruitments. Furthermore, anthropomorphizing AI recruiters can serve as a mitigation strategy for negative effects, particularly when delivering unfavorable recruitment results with AI. These findings suggest that this could be an effective solution to the issue identified in most prior studies, where the introduction of AI instead of humans in recruitment often resulted in lower perceptions of interaction justice (Acikgoz et al., 2020; Bankins et al., 2022).

Furthermore, in terms of procedural justice, the phenomenon of outcome bias was emerged, indicating that Machine-like recruiters delivering positive outcomes yielded significantly higher levels of procedural justice than Human-like recruiters delivering negative outcomes. This research finding suggests that the outcome bias phenomenon, as observed in the study by Bankins et al. (2022), where AI delivering positive outcomes is perceived as more job-appropriate, respectful, and unbiased than humans delivering negative outcomes, may also apply similarly to the context of considering procedural justice.

These findings highlight the importance of considering not only the type of the AI recruiter, but also the content of recruitment outcomes and the context in which they are conveyed.

### Theoretical Implication

This study holds theoretical significance in two main aspects. First, this study contributes to the field of Human Resource Management by examining the novel aspect of AI's type on the applicant's perception. According to the previous research in AI Human Resource Management, most of the studies have focused on AI versus Human or AI-human collaboration perspectives, resulting in a lack of studies considering how the company should consider the characteristics or form of AI itself when they decide to apply the AI solution to their company. By investigating the influence of AI's type on consumer perceptions within the context of AI-based recruitments, this study demonstrates that the results of comparing Human-like AI and Machine-like AI may differ from the results of previous research comparing AI and Humans. Therefore, this study suggests that while research focusing on future strategies for AI adoption through collaboration with humans is currently receiving considerable attention in academia, studies that prioritize the adoption of AI products themselves by considering the characteristics or form of AI are also important.

Furthermore, this study has significance in combining the form of AI services with a new variable called Valence in the context of AI decision-making. The study demonstrates that situational contexts, such as Valence, can influence user perceptions.



Particularly, it reveals the presence of the outcome bias phenomenon, where positive outcomes are perceived to have higher levels of procedural justice regardless of the decision-maker's attribute.

Therefore, this study highlights the importance of considering not only technological capabilities and user characteristics, but also the situational context of Valence as a crucial factor when determining consumer perceptions in the future adoption of AI-related new products by companies.

### **Practical Implication**

This study holds practical significance in providing insights into the AI Recruitment adoption strategies for companies. First of all, it identifies specific conditions where the form of AI recruiters can influence applicants' perceptions. By demonstrating that in contexts requiring the delivery of negative recruitment outcomes, a human-like AI recruiter is perceived to exhibit higher levels of interactional justice and organizational attractiveness compared to a machine-like AI recruiter, the study emphasized the need to further explore the humanization of AI recruiters and investigate diverse perceptions and responses of applicants based on the form of AI recruiters.

Second, the study indicates that companies should consider varying the delivery approach based on recruitment outcomes when implementing AI Recruitments. According to the study findings, regardless of the form of AI recruiter, positive outcomes were associated with higher perceived procedural justice than negative outcomes. Moreover, in the same form of AI Recruitment conditions, positive outcomes yielded high scores in perceived justice and organizational attractiveness compared to the negative outcome condition.

Based on this study, organizations should prioritize the adoption of AI in the context of conveying positive decision-making during the implementation of AI Recruitments. However, in contexts where negative outcomes need to be delivered, it is essential to consider various strategies that can mitigate users' negative perceptions of AI recruiters. In this study, it is demonstrated that utilizing a Human-like AI recruiter is an effective solution for mitigating applicants' negative reactions compared to a Machine-like AI recruiter in terms of the perception aspects of Interactional Justice and Organizational Attractiveness.

However, concerning Procedural Justice, it suggests that beyond merely anthropomorphizing AI recruiters, there is a need for consideration of various strategies to address Outcome bias and alleviate negative perceptions, particularly when dealing with unfavorable outcomes. For instance, one approach is to design a voice channel in the recruitment process that allows participants to express their opinions regarding AI Recruitments, thereby increasing feedback acceptance. Additionally, exploring and implementing strategies such as utilizing explainable AI in the decision-making process, which enhances transparency, can help alleviate users' negative perceptions and outcome bias of procedural justice through AI Recruitments. These efforts are crucial in mitigating negative perceptions and outcome bias and should be actively considered when introducing AI Recruitment systems.

### **Limitation and Future Research Directions**

This study identifies three significant limitations and proposes future research directions. First, there is a concern regarding external validity. The study employed virtual AI Recruitment scenarios to validate the main research hypotheses. However, this approach may introduce a potential discrepancy with real-world contexts. To address this limitation, the study used existing literatures on AI Recruitments to design experiments. Nevertheless, given the variability in recruitment methods and formats for optimized candidate selection across different organizations, future research could benefit from conducting studies that compare the applicants' perceptions in an actual AI Recruitment environment or by utilizing real-world AI Recruitment service data.

Second, there is an issue regarding the distribution of survey respondents. The study found that a majority of the survey participants lacked prior experience with AI Recruitments, which limits the generalizability of the findings. As the adoption of AI Recruitments is gradually increasing in organizations, it is recommended that future research focus on validating the practical effects of AI Recruitments by exclusively targeting individuals with actual AI Recruitment experience. Additionally, considering that prior experience with technology can act as a significant research variable, it would be valuable to investigate the impact of experience on perceptions by incorporating prior AI Recruitment experience as a relevant research variable.

For the last, this study faces a challenge in stimulus manipulation. To simplify the research design, the study simplified the manipulation of anthropomorphism by categorizing stimuli into human-like and machine-like categories. Although a manipulation check confirmed a significant difference in anthropomorphism levels between the two stimulus types, this simplified approach may restrict the study's scope.

Anthropomorphism encompasses not only visual elements but also intricate interactions involving verbal and non-verbal factors like motion and tone. Thus, future research should consider the specific impacts of each specific dimension of anthropomorphism and propose a more comprehensive examination by categorizing anthropomorphism levels as high, medium, and low. This will enable a more delicate investigation of the effects based on the degree of AI anthropomorphism.

### **ACKNOWLEDGMENT**

This research was supported by the MSIT (Ministry of Science and ICT), Republic of Korea, under the ITRC (Information Technology Research Center), Republic of Korea, support program (IITP-2020-0-01787) supervised by the IITP (Institute of Information & Communications Technology Planning & Evaluation), Republic of Korea.

## REFERENCES

- Acikgoz, Y., Davison, K. H., Compagnone, M., & Laske, M. (2020). Justice perceptions of artificial intelligence in selection, *International Journal of Selection and Assessment*, 28(4), 399-416. <https://doi.org/10.1111/ijisa.12306>
- Adams, J. S. (1965). Inequity in social exchange. In *Advances in experimental social psychology*, 2, 267-299. Academic Press.
- Araujo, T., Helberger, N., Kruike-meier, S., & De Vreese, C. H. (2020). In AI we trust? Perceptions about automated decision-making by artificial intelligence. *AI & society*, 35, 611-623. <https://doi.org/10.1007/s00146-019-00931-w>
- Baek, T. H., & Kim, M. (2023). Ai robo-advisor anthropomorphism: The impact of anthropomorphic appeals and regulatory focus on investment behaviors, *Journal of Business Research*, 164, 114039. <https://doi.org/10.1016/j.jbusres.2023.114039>
- Bankins, S., Formosa, P., Griep, Y., & Richards, D. (2022). AI decision making with dignity? Contrasting workers' justice perceptions of human and AI decision making in a human resource management context, *Information Systems Frontiers*, 24(3), 857-875. <https://doi.org/10.1007/s10796-021-10223-8>
- Bell, B. S., Wiechmann, D., & Ryan, A. M. (2006). Consequences of organizational justice expectations in a selection system. *Journal of Applied Psychology*, 91(2), 455. <https://doi.org/10.1037/0021-9010.91.2.455>
- Bies, R. J., & Moag, J. F. (1986) Interactional justice: Communication criteria of fairness. In R. J. Lewicki, B. H. Sheppard, & M. H. Bazerman (Eds.), *Research on negotiations in organizations*, 1, 43-55. Greenwich, CT: JAI Press.
- Bickmore, T. W., & Picard, R. W. (2005). Establishing and maintaining long-term human-computer relationships, *ACM Transactions on Computer-Human Interaction (TOCHI)*, 12(2), 293-327. <https://doi.org/10.1145/1067860.1067867>
- Black, J. S., & van Esch, P. (2020). AI-enabled recruiting: What is it and how should a manager use it?, *Business Horizons*, 63, 215-226. <https://doi.org/10.1016/j.bushor.2019.12.001>
- Budhwar, P., Chowdhury, S., Wood, G., Aguinis, H., Bamber, G. J., Beltran, J. R., ... & Varma, A. (2023). Human resource management in the age of generative artificial intelligence: Perspectives and research directions on ChatGPT, *Human Resource Management Journal*. 33(3), 606-659. <https://doi.org/10.1111/1748-8583.12524>
- Ciechanowski, L., Przegalinska, A., Magnuski, M., & Gloor, P. (2019). In the shades of the uncanny valley: An experimental study of human-chatbot interaction, *Future Generation Computer Systems*, 92, 539-548. <https://doi.org/10.1016/j.future.2018.01.055>
- Chapman, D. S., Uggerslev, K. L., Carroll, S. A., Piasentin, K. A., & Jones, D. A. (2005). Applicant attraction to organizations and job choice: a meta-analytic review of the correlates of recruiting outcomes, *Journal of applied psychology*, 90(5), 928. <https://doi.org/10.1037/0021-9010.90.5.928>
- Chapman, D. S., Uggerslev, K. L., & Webster, J. (2003). Applicant reactions to face-to-face and technology-mediated interviews: A field investigation, *Journal of applied psychology*, 88(5), 944. <https://doi.org/10.1037/0021-9010.88.5.944>
- Chi, C. G. Q., Wen, B., & Ouyang, Z. (2020). Developing relationship quality in economy hotels: the role of perceived justice, service quality, and commercial friendship, *Journal of Hospitality Marketing & Management*, 29(8), 1027-1051. <https://doi.org/10.1080/19368623.2020.1748158>
- Colquitt, J. A. (2001). On the dimensionality of organizational justice: a construct validation of a measure, *Journal of applied psychology*, 86(3), 386. <https://doi.org/10.1037/0021-9010.86.3.386>
- Colquitt, J. A., Greenberg, J., & Zapata-Phelan, C. P. (2013). What is organizational justice? A historical overview. In *Handbook of organizational justice* (pp. 3-56). Psychology Press.
- Crolic, C., Thomaz, F., Hadi, R., & Stephen, A. T. (2022). Blame the bot: Anthropomorphism and anger in customer-chatbot interactions, *Journal of Marketing*, 86(1), 132-148. <https://doi.org/10.1177/00222429211045687>
- De Visser, E. J., Monfort, S. S., Goodyear, K., Lu, L., O'Hara, M., Lee, M. R., ... & Krueger, F. (2017). A little anthropomorphism goes a long way: Effects of oxytocin on trust, compliance, and team performance with automated agents, *Human factors*, 59(1), 116-133. <https://doi.org/10.1177/0018720816687205>
- Fan, A., Wu, L., Miao, L., & Mattila, A. S. (2020). When does technology anthropomorphism help alleviate customer dissatisfaction after a service failure? The moderating role of consumer technology self-efficacy and interdependent self-construal, *Journal of Hospitality Marketing & Management*, 29(3), 269-290. <https://doi.org/10.1080/19368623.2019.1639095>
- Folger, N., Brosi, P., Stumpf-Wollersheim, J., & Welpe, I. M. (2021). Applicant reactions to digital selection methods: A signaling perspective on innovativeness and procedural justice, *Journal of Business and Psychology*, 1-23. <https://doi.org/10.1007/s10869-021-09770-3>
- Franke, C., Groeppel-Klein, A., & Müller, K. (2023). Consumers' responses to virtual influencers as advertising endorsers: novel and effective or uncanny and deceiving?, *Journal of Advertising*, 52(4), 523-539. <https://doi.org/10.1080/00913367.2022.2154721>
- Garvey, A. M., Kim, T., & Duhachek, A. (2023). Bad news? Send an AI. Good news? Send a human', *Journal of Marketing*, 87(1), 10-25. <https://doi.org/10.1177/00222429211066972>
- Gonzalez, M. F., Capman, J. F., Oswald, F. L., Theys, E. R., & Tomczak, D. L. (2019). "Where's the IO?" Artificial intelligence and machine learning in talent management systems, *Personnel Assessment and Decisions*, 5(3), 5. <https://doi.org/10.25035/pad.2019.03.005>
- Gonzalez, M. F., Liu, W., Shirase, L., Tomczak, D. L., Lobbe, C. E., Justenhoven, R., & Martin, N. R. (2022). Allying with AI? Reactions toward human-based, AI/ML-based, and augmented hiring processes, *Computers in Human Behavior*, 130, 107179. <https://doi.org/10.1016/j.chb.2022.107179>

- Han, S., & Yang, H. (2018). Understanding adoption of intelligent personal assistants: A parasocial relationship perspective, *Industrial Management & Data Systems*, 118(3), 618-636. <https://doi.org/10.1108/IMDS-05-2017-0214>
- Harris, M. M., & Fink, L. S. (1987). A field study of applicant reactions to employment opportunities: Does the recruiter make a difference?, *Personnel Psychology*, 40(4), 765-784. <https://doi.org/10.1111/j.1744-6570.1987.tb00623.x>
- Highhouse, S., Lievens, F., & Sinar, E. F. (2003). Measuring attraction to organizations, *Educational and psychological Measurement*, 63(6), 986-1001. <https://doi.org/10.1177/0013164403258403>
- Hmoud, B. I., & Várallyai, L. (2020). Artificial intelligence in human resources information systems: Investigating its trust and adoption determinants, *International Journal of Engineering and Management Sciences*, 5(1), 749-765. <https://doi.org/10.21791/IJEMS.2020.1.65>
- Hunkenschroer, A. L., & Luetge, C. (2022). Ethics of AI-enabled recruiting and selection: A review and research agenda, *Journal of Business Ethics*, 178(4), 977-1007. <https://doi.org/10.1007/s10551-022-05049-6>
- Jiang, K., Qin, M., & Li, S. (2022). Chatbots in retail: How do they affect the continued use and purchase intentions of Chinese consumers?, *Journal of Consumer Behaviour*, 21(4), 756-772. <https://doi.org/10.1002/cb.2034>
- Jiang, L., Qin, X., Yam, K. C., Dong, X., Liao, W., & Chen, C. (2023). Who should be first? How and when AI-human order influences procedural justice in a multistage decision-making process, *Plos one*, 18(7), e0284840. <https://doi.org/10.1371/journal.pone.0284840>
- Konradt, U., Okimoto, T., Garbers, Y., & Otte, K. P. (2020). The shape of justice repair: Asymmetric nonlinear retributive and restorative justice effects to unfair supervisor treatment, *International Journal of Conflict Management*, 31(2), 149-173. <https://doi.org/10.1108/IJCMA-06-2019-0096>
- Lee, B. C., & Kim, B. Y. (2021). Development of an AI-based interview system for remote hiring, *International Journal of Advanced Research in Engineering and Technology (IJARET)*, 12(3), 654-663. <https://doi.org/10.34218/IJARET.12.3.2021.0.60>
- Lee, J. C., & Chen, X. (2022). Exploring users' adoption intentions in the evolution of artificial intelligence mobile banking applications: the intelligent and anthropomorphic perspectives, *International Journal of Bank Marketing*, 40(4), 631-658. <https://doi.org/10.1108/IJBM-08-2021-0394>
- Lee, M. K. (2018). Understanding perception of algorithmic decisions: Fairness, trust, and emotion in response to algorithmic management, *Big Data & Society*, 5(1), 2053951718756684. <https://doi.org/10.1177/2053951718756684>
- Leventhal, G. S. (1980). What should be done with equity theory? New approaches to the study of fairness in social relationships, In *Social exchange: Advances in theory and research* (pp. 27-55). Boston, MA: Springer US.
- Li, M., & Suh, A. (2022). Anthropomorphism in AI-enabled technology: A literature review, *Electronic Markets*, 32(4), 2245-2275. <https://doi.org/10.1007/s12525-022-00591-7>
- Li, X., & Sung, Y. (2021). Anthropomorphism brings us closer: The mediating role of psychological distance in User-AI assistant interactions, *Computers in Human Behavior*, 118, 106680. <https://doi.org/10.1016/j.chb.2021.106680>
- Loureiro, S. M. C., Guerreiro, J., & Tussyadiah, I. (2021) Artificial intelligence in business: State of the art and future research agenda, *Journal of business research*, 129, 911-926. <https://doi.org/10.1016/j.jbusres.2020.11.001>
- Lucas, G. M., Gratch, J., King, A., & Morency, L. P. (2014). It's only a computer: Virtual humans increase willingness to disclose. *Computers in Human Behavior*, 37, 94-100. <https://doi.org/10.1016/j.chb.2014.04.043>
- Maurer, R. (2020) 'Job interviews go virtual in response to COVID-19'. *Society for Human Resources Management*. Retrieved from <https://www.shrm.org/resourcesandtools/hr-topics/talent-acquisition/pages/job-interviews-go-virtual-response-covid-19-coronavirus.aspx> (accessed 14 September 2023).
- Miller, F. A., Katz, J. H., & Gans, R. (2018). The OD imperative to add inclusion to the algorithms of artificial intelligence. *OD practitioner*, 50(1), 8.
- Mirowska, A., & Mesnet, L. (2022). Preferring the devil you know: Potential applicant reactions to artificial intelligence evaluation of interviews. *Human Resource Management Journal*, 32(2), 364-383. <https://doi.org/10.1111/1748-8583.12393>
- Mou, Y., & Xu, K. (2017). The media inequality: Comparing the initial human-human and human-AI social interactions. *Computers in Human Behavior*, 72, 432-440. <https://doi.org/10.1016/j.chb.2017.02.067>
- Nass, C., & Moon, Y. (2000). Machines and mindlessness: Social responses to computers. *Journal of social issues*, 56(1), 81-103. <https://doi.org/10.1111/0022-4537.00153>
- Newman, D. T., Fast, N. J., & Harmon, D. J. (2020) 'When eliminating bias isn't fair: Algorithmic reductionism and procedural justice in human resource decisions', *Organizational Behavior and Human Decision Processes*, 160, 149-167. <https://doi.org/10.1016/j.obhdp.2020.03.008>
- Noble, S. M., Foster, L. L., & Craig, S. B. (2021) 'The procedural and interpersonal justice of automated application and resume screening', *International Journal of Selection and Assessment*, 29(2), 139-153. <https://doi.org/10.1111/ijsa.12320>
- Pan, Y., Froese, F., Liu, N., Hu, Y., & Ye, M. (2022) 'The adoption of artificial intelligence in employee recruitment: The influence of contextual factors', *The International Journal of Human Resource Management*, 33(6), 1125-1147. <https://doi.org/10.1080/09585192.2021.1879206>
- Qiu, H., Li, M., Shu, B., & Bai, B. (2020) 'Enhancing hospitality experience with service robots: The mediating role of rapport building', *Journal of Hospitality Marketing & Management*, 29(3), 247-268. <https://doi.org/10.1080/19368623.2019.1645073>
- Qiu, L., & Benbasat, I. (2009) 'Evaluating anthropomorphic product recommendation agents: A social relationship perspective to designing information systems', *Journal of management information systems*, 25(4), 145-182. <https://doi.org/10.2753/MIS0742-1222250405>

- Reeves, B., & Nass, C. (1996) *The media equation: How people treat computers, television, and new media like real people*. Cambridge, UK, 10(10).
- Researchandmarket(2023). *Global Artificial Intelligence in HR Market (2023-2028) by Offering, Technology, Application, Industry and Geography, Competitive Analysis, and the Impact of Covid-19 with Ansoff Analysis*. Infogence Global Research.
- Schlicker, N., Langer, M., Ötting, S. K., Baum, K., König, C. J., & Wallach, D. (2021). What to expect from opening up ‘black boxes’? Comparing perceptions of justice between human and automated agents. *Computers in Human Behavior*, 122, 106837. <https://doi.org/10.1016/j.chb.2021.106837>
- Schmider, E., Ziegler, M., Danay, E., Beyer, L., & Bühner, M. (2010). Is it really robust? Reinvestigating the robustness of ANOVA against violations of the normal distribution, *European Research Journal of Methods for the Behavioral and Social Sciences*, 6(4), 147-151.
- Sestino, A., & D'Angelo, A. (2023). My doctor is an avatar! The effect of anthropomorphism and emotional receptivity on individuals' intention to use digital-based healthcare services. *Technological Forecasting and Social Change*, 191, 122505. <https://doi.org/10.1016/j.techfore.2023.122505>
- Sheehan, B., Jin, H. S., & Gottlieb, U. (2020). Customer service chatbots: Anthropomorphism and adoption. *Journal of Business Research*, 115, 14-24. <https://doi.org/10.1016/j.techfore.2023.122505>
- Smith, A. K., Bolton, R. N., & Wagner, J. (1999). A model of customer satisfaction with service encounters involving failure and recovery, *Journal of Marketing Research*, 36(3), 356–372. <https://doi.org/10.1177/002224379903600305>
- Statista. (2020). *Global recruiting trends: Importance of artificial intelligence by country 2017*. Statista.
- Stone, D. L., Deadrick, D. L., Lukaszewski, K. M., & Johnson, R. (2015). The influence of technology on the future of human resource management. *Human resource management review*, 25(2), 216-231. <https://doi.org/10.1016/j.hrmr.2015.01.002>
- Strohmaier, N., Pluut, H., Van den Bos, K., Adriaanse, J., & Vriesendorp, R. (2021). Hindsight bias and outcome bias in judging directors' liability and the role of free will beliefs, *Journal of Applied Social Psychology*, 51(3), 141-158. <https://doi.org/10.1111/jasp.12722>
- Van Esch, P., Black, J. S., & Ferolie, J. (2019). Marketing AI recruitment: The next phase in job application and selection, *Computers in Human Behavior*, 90, 215-222. <https://doi.org/10.1016/j.chb.2018.09.009>
- Wang, X., Min, Q., & Liu, Z. (2021). Antecedents and Impact of Applicants' Perceived Interactional Justice in AI-based Job Interviews. *PACIS 2021 Proceedings*. Dubai, UAE, p. 29.
- Walker, H. J., Helmuth, C. A., Feild, H. S., & Bauer, T. N. (2015). Watch what you say: Job applicants' justice perceptions from initial organizational correspondence. *Human resource management*, 54(6), 999-1011. <https://doi.org/10.1002/hrm.21655>
- Wilhelmy, A., Kleinmann, M., Melchers, K. G., & Lievens, F. (2019). What do consistency and personableness in the interview signal to applicants? Investigating indirect effects on organizational attractiveness through symbolic organizational attributes, *Journal of Business and Psychology*, 34(5), 671-684. <https://doi.org/10.1007/s10869-018-9600-7>
- Xie, Y., Zhu, K., Zhou, P., & Liang, C. (2023). How does anthropomorphism improve human-AI interaction satisfaction: a dual-path model, *Computers in Human Behavior*, 148, 107878. <https://doi.org/10.1016/j.chb.2023.107878>
- Yang, Y., Liu, Y., Lv, X., Ai, J., & Li, Y. (2022). Anthropomorphism and customers' willingness to use artificial intelligence service agents, *Journal of Hospitality Marketing & Management*, 31(1), 1-23. <https://doi.org/10.1080/19368623.2021.1926037>



## Can CAPM (Capital Asset Pricing Model) accurately value assets?

Peter Brusov<sup>1,\*</sup>  
Tatiana Filatova<sup>2</sup>  
Veniamin Kulik<sup>3</sup>  
She-I Chang<sup>4</sup>  
George Lin<sup>5</sup>  
Li-Min Chang<sup>6</sup>

\*Corresponding author

<sup>1</sup> Department of Mathematics, Financial University under the Government of Russian Federation, Moscow, Russia; pnb1983@yahoo.com

<sup>2</sup> Department of financial and investment management, Financial University under the Government of Russian Federation. Moscow, Russia, tvfilatova@fa.ru

<sup>3</sup> Faculty of Information Technology and big data analysis, Financial University under the Government of Russian Federation, Moscow, Russia, venya.kulik@mail.ru

<sup>4</sup> College of Management, National Chung Cheng University, Taiwan, actsic@ccu.edu.tw

<sup>5</sup> College of Management, National Chung Cheng University, Taiwan, actycl@ccu.edu.tw

<sup>6</sup> College of Management, National Chung Cheng University, Taiwan, changclm@gmail.com

### ABSTRACT

A comprehensive analysis of CAPM (Capital Asset Pricing Model) was carried out. Our analysis within CAPM for several dozen listed companies from different countries, as well as numerous results of other authors, showed that the CAPM results differ significantly from the real returns of companies. The reasons for this discrepancy are discussed, which are related to the internal properties and shortcomings of the model, as well as its possible modifications that can bring the model closer to real life. Among the latter, accounting for financial risk in CAPM along with business risk, various amendments such as the Fama-French corrections, Arbitrage Pricing Theory (APT) and the incorporation of CAPM into modern capital structure theories. Accounting for financial risk in CAPM along with business risk was made by Brusov, Filatova and Kulik recently analytically (CAPM 2.0 model), in contrast to the phenomenological model of Hamada, and a large difference in these results was emphasized. In addition to the renormalization of the beta-coefficient, obtained in the Hamada model, two additional terms are found: the renormalized risk-free return and the term dependent on the cost of debt kd. Disadvantages of Hamada's model are discussed. Two versions of CAPM (market and industry) are considered and it is shown that the latter is closer to real life.

*Keywords:* Business and financial risks, capital structure, Modigliani–Miller (MM) theory, Brusov–Filatova–Orekhova (BFO) theory, risk and profitability, Fama–French model

### INTRODUCTION

The famous Capital Asset Pricing Model (CAPM), based on the portfolio theory by Harry Markowitz, was developed independently by Jack Traynor (1961), William F. Sharp (1964), John Lintner (1965) and Jan Mossin (1966). The Capital Asset Pricing Model (CAPM) is still widely used to estimate the return on assets and investments. But as our CAPM analysis for several dozen listed companies from different countries, as well as numerous results from other authors, has shown, CAPM results differ significantly from the actual profitability of companies. The reasons for this discrepancy are discussed, related to the internal properties and shortcomings of the model. As well we discuss possible modifications of CAPM (Hamada, R. 1969, 1972; Fama E. 1965; Fama, E. and French 1992, 1993, 1995; Brusov, Filatova, Kulik 2023) that can bring the model closer to real life. Among the latter is the account of financial risk in CAPM along with business risk, which was recently correctly done by Brusov, Filatova, Kulik (2023), and the first attempt to take financial risk into account (not completely successful) was made by Hamada R. (1969, 1972). Initial Capital Asset Pricing Model (CAPM) takes into account only business risk. In practice, companies use debt financing and operate at non-zero levels of leverage. This means that it is necessary to take into account the financial risk associated with the use of debt financing along with business one. Brusov, Filatova, Kulik (2023) simultaneously take into account the business and financial risk. A new approach to CAPM has been developed that takes into account both business and financial risk. They combine the theory of

CAPM and the Modigliani–Miller (MM) theory. The first is based on portfolio analysis and accounting for business risks in relation to the market (or industry). The second one (the Modigliani–Miller (MM) theory) describes a specific company and takes into account the financial risks associated with the use of debt financing. The combination of these two different approaches makes it possible to take into account both types of risks: business and financial ones. Brusov, Filatova, Kulik (2023) combine these two approaches analytically, while Hamada (1969, 1972) did it phenomenologically. Using the Modigliani–Miller (MM) theory, it is shown that the Hamada’s model, first model, used for this purpose half a century ago, is incorrect. In addition to the renormalization of the beta-coefficient, obtained in the Hamada model, two additional terms are found: the renormalized risk-free return and the term dependent on the cost of debt  $k_d$ . A critical analysis of the Hamada model was carried out. The vast majority of listing companies use debt financing and are levered, and the Hamada model is not applicable to them in contrast to a new (Brusov, Filatova, Kulik) approach applicable to leveraged companies. Implemented a new approach to specific companies. A comparison of the results of the new approach with the results of the conventional CAPM is shown. Two versions of CAPM (market or industry) are considered (Brusov, Filatova, Kulik 2023).

One more modification of the CAPM has been done in 1992, by Y. Fama and K. French, who proved that future returns are also affected by factors such as company size and industry affiliation. They have developed three- and five- factor models (Fama, E. and French 1992, 1993, 1995).

Alternative to CAPM is the Arbitrage Pricing Theory (APT), created by Stephen Ross in 1976. In opposite to the CAPM, which has only one factor and one beta, the APT formula has multiple factors that include non-company factors, which requires the asset's beta with respect to each separate factor. The APT does not explain what these factors are, and APT model users should analytically determine factors that might affect the asset's returns. The factor used in the CAPM is the difference between the market rate of return and the risk-free rate of return.

The CAPM is a single-factor model and is easier to use, which is why investors prefer to use it to estimate the expected rate of return rather than using the APT, which requires users to estimate multiple factors.

#### DERIVATION OF THE CAPM FORMULA

To derive the CAPM formula, we create a portfolio of asset  $i$  and the market portfolio  $M$ ;  $(\alpha, 1 - \alpha)$ , with the price share of the security in the portfolio  $\alpha \in [0,1]$  (Sigman Karl 2005). The rate of return is thus  $\mu(\alpha) = \alpha\mu_i + (1 - \alpha)\mu_M$ . Asset  $i$  is assumed not efficient; it's point lies in the feasible region but not on the efficient frontier. Thus as  $\alpha$  varies this portfolio's point traces out a smooth curve in the feasible  $(\sigma, \mu)$  region  $\alpha \rightarrow (\sigma(\alpha), \mu(\alpha))$  parametrized by  $\alpha$ , where

$$\mu(\alpha) = \alpha\mu_i + (1 - \alpha)\mu_M = \alpha(\mu_i - \mu_M) + \mu_M \quad (1)$$

Using well known formula for portfolio dispersion

$$\sigma^2(\alpha) = \alpha^2\sigma_i^2 + (1 - \alpha)^2\sigma_M^2 + 2\alpha(1 - \alpha)\sigma_{M,i}, \quad (2)$$

one gets

$$\begin{aligned} \sigma(\alpha) &= \sqrt{\alpha^2\sigma_i^2 + (1 - \alpha)^2\sigma_M^2 + 2\alpha(1 - \alpha)\sigma_{M,i}} = \\ &= \sqrt{\alpha^2(\sigma_i^2 + \sigma_M^2 - 2\sigma_{M,i}) + \sigma_M^2 + 2\alpha(\sigma_{M,i} - \sigma_M^2)} \end{aligned} \quad (3)$$

When  $\alpha = 0$   $(\sigma(0), \mu(0)) = (\sigma_M, \mu_M)$  and when  $\alpha = 1$   $(\sigma(1), \mu(1)) = (\sigma_i, \mu_i)$ . Thus the curve touches the capital market line at the market point  $(\sigma_M, \mu_M)$ , but otherwise remains off the capital market line but (of course) within the feasible region where it also hits the point  $(\sigma_i, \mu_i)$ . We conclude that the curve is tangent to the capital asset line at point  $(\sigma_M, \mu_M)$  and therefore when  $\alpha = 0$  the curve's derivative

$$\frac{d\mu(\alpha)}{d\sigma(\alpha)}_{\alpha=0} \quad (4)$$

is identical to the slope of the capital asset line at point M. The slope (the price of risk) of the line is given by (2). We thus conclude that when  $\alpha = 0$

$$\frac{d\mu(\alpha)}{d\sigma(\alpha)} = \frac{\mu_M - \mu_f}{\sigma_M}. \quad (5)$$

The composition rule from calculus yields

$$\frac{d\mu(\alpha)}{d\sigma(\alpha)} = \frac{d\mu(\alpha)/d\alpha}{d\sigma(\alpha)/d\alpha}. \quad (6)$$

Differentiating (1) and (3) and evaluating at  $\alpha = 0$  yields

$$\frac{d\mu(\alpha)}{d\sigma(\alpha)} = \frac{\mu_i - \mu_M}{(\sigma_{M,i} - \sigma_M^2)/\sigma_M} \quad (7)$$

From (5) we deduce that

$$\frac{\mu_i - \mu_M}{(\sigma_{M,i} - \sigma_M^2)/\sigma_M} = \frac{\mu_M - \mu_f}{\sigma_M} \quad (6)$$

Solving this equation for  $\mu_i$ , we obtain the CAPM formula for the asset  $I$  (CAPM formula for single asset  $i$ )

$$\mu_i - \mu_f = \beta_i \cdot (\mu_M - \mu_f), \quad (7)$$

as was to be shown. For the more general portfolio result, observe that

$$\mu_p - \mu_f = -\mu_f + \sum_{i=1}^n \alpha_i \mu_i = \sum_{i=1}^n \alpha_i (\mu_i - \mu_f) = \sum_{i=1}^n \alpha_i \beta_i (\mu_M - \mu_f) = (\mu_M - \mu_f) \sum_{i=1}^n \alpha_i \beta_i \quad (8)$$

Note that when  $\beta_p = 1$  then  $\mu_p = \mu_M$ ; the expected rate of return is the same as for the market portfolio. When  $\beta_p > 1$ , then  $\mu_p > \mu_M$ ; when  $\beta_p < 1$ , then  $\mu_p < \mu_M$ .

In case of negatively correlated asset  $i$  with M,  $\sigma_{M,i} < 0$ , then  $\beta_i < 0$  and  $\mu_i < \mu_f$ ; the expected rate of return is less than the risk-free rate. Effectively, such a negatively correlated asset serves as insurance against a drop in the market returns, and might be viewed by some investors as having enough such advantages so as to make it worth the low return. Such an example could be investing in gold.

### CAPM (CAPITAL ASSET PRICING MODEL) PROPERTIES

CAPM is a simple, but widely used, one-factor model that describes the relationship between the expected return on assets (stocks, investments, etc.) and the risk-free rate, taking into account systematic (business) risk. This relationship is described by the equity risk premium, which depends on the asset's beta (which describes the asset's correlation or sensitivity to the market), the risk-free rate (say, the Treasury bill rate or the central bank's key rate), and the expected return in the market. CAPM assumes an idealized open market structure where all risky assets refer to all tradable shares available to everyone. In addition, we have a risk-free asset (for borrowing and/or lending in unlimited quantities) with an interest rate of  $k_f$ . One assumes that all information is available to everyone, such as covariances, variances, average stock returns and so on. It is also assumed that the investor is a rational, risk-averse, who uses the same Markowitz portfolio theory.



### The Assumptions are Made Within the CAPM Model

The following assumptions are made within the CAPM model:

- 1) All investors are risk averse and have the same time frame to evaluate information.
- 2) Unlimited capital exists to borrow at the risk-free rate.
- 3) Investments can be divided into unlimited parts and sizes.
- 4) Taxes, inflation and transaction costs are absent.
- 5) Return and risk are linearly related.

CAPM (Capital Asset Pricing Model) describes the profitability of asset and is described by the following formula

$$k_i = k_f + \beta_i (k_m - k_f). \quad (9)$$

(Note, that here and below we will denote assets profitability as  $k$  (like cost of equity) instead of  $r$ .)

Here  $k_f$  is risk free profitability,  $\beta$  is the  $\beta$ -coefficient of the company. It shows the dependence of the return on the asset and the return on the market as a whole. The  $\beta$ -coefficient is described by the following formula

$$\beta_i = \frac{\text{COV}_{im}}{\sigma_m^2} = \rho_{im} \frac{\sigma_i}{\sigma_m}. \quad (10)$$

Here  $\sigma_i$  is the risk (standard deviation) of  $i$ -th asset,  $\sigma_m$  is market risk (standard deviation of market index),  $\text{COV}_{im}$  is covariance between  $i$ -th asset and market portfolio.

An investor invests in risky securities only if their return is higher than the return on risk-free securities, so always  $k_i > k_f$  and  $k_m > k_f$ .

The beta-coefficient of a security,  $\beta$ , has the meaning of the amount of riskiness of this security. It follows from formula (9) that:

- 1) if  $\beta=1$  the yield of the security is equal to the yield of the average market portfolio ( $k_i = k_f$ );
- 2) if  $\beta > 1$ , the security is more risky than the average on the security market ( $k_i > k_f$ );
- 3) if  $\beta < 1$ , the security is less risky than the average on the security market ( $k_i < k_f$ ).

Securities betas are calculated using statistical data on returns on specific securities and the average market returns on securities traded on the market.

### Disadvantages of the CAPM model

CAPM has some well-known disadvantages.

1. The CAPM formula only works under assumption that the market is dominated by purely rational players who make decisions that favor only investment returns. This, of course, is not always true.
2. CAPM assumes that each market participant acts on the basis of the same information. In reality, relevant information is distributed unevenly among the public, so some participants may make decisions based on information that others do not.
3. Using beta as the main part of the formula. But beta takes into account only changes in the stock price in the market. However the share price can change for reasons other than the market. Stocks can rise or fall in value for deliberate reasons, not just volatility.
4. CAPM only uses historical data. But historical stock price changes are not enough to determine the overall risk of an investment. Other factors should be considered, such as economic conditions, industry peculiarities and competitor characteristics, and internal and external activities of the company itself.

So, the model has a number of limitations: the model does not take into account taxes, transaction costs, non-transparency of the financial market, etc.

Finally, to predict future returns, a retrospective level of market risk is used, which leads to a forecast error.

### MODIFICATIONS OF THE CAPITAL ASSET PRICING MODEL (CAPM)

The CAPM approach is still evolving and we will describe some of the directions of this development below.

#### The Distribution Function: The Symmetric CAPM

One of the remaining internal problems of CAPM is the distribution function. The Capital Asset Pricing Model (CAPM) assumes a Gaussian or Normal distribution. In practice, this assumption may be violated. In paper (Leal D. et al. 2023) a symmetric CAPM is proposed, assuming distributions with lighter or heavier tails than the normal distribution. Elliptic distributions (normal, exponential and Student-t) are considered. This consideration is of a general nature. Authors conducted a detailed case study to apply the obtained results estimating the systematic risk of the financial assets of a Chilean company with real data. A Chilean company is just illustration of obtained results. In addition, Leal D. et al. (2023) study the methods of leverage and local impact for diagnostics in a symmetric CAPM. It is concluded that the considered models give better results than the CAPM with Gaussian distribution.

In (Zhou, G. 1993; Lange, K. et al. L. 1989 and Chen, J.; Wu, Y.; Xu, Y. 2021) an empirical studies were carried out under the assumption that stock returns have distributions with heavier tails than the normal distribution. The Student-t distribution instead of the normal distribution was considered in (Lange, K. et al. L. 1989) and in (Blattberg, R.C.; Gonedes, N.J. 1974), taking into account the maximum likelihood method for estimating its parameters. Paper (Chen, J.; Wu, Y.; Xu, Y. 2021) concluded that asset valuation should be carried out within the framework of the CAPM and the discounted dividend model.

#### The Multiple Factors Models

The CAPM operates on only one factor that affects the future performance of a stock.

There are several models with multiple factors that modify the CAPM in this regard. Among them are Fama-French (three- and five-factor models) and APT (Arbitrage Pricing Theory) models.

#### *Fama-French model*

In 1992, Y. Fama and K. French (Fama and French, 1992) proved that future returns are also affected by factors such as company size and industry affiliation. They have developed three- and five- factor models.

#### *Fama-French Three-factor Model*

Fama-French three-factor model takes into account two additional risk factors, namely, size and book to market equity along with market beta

$$k_e = k_f + \beta_U(k_m - k_f) + s \cdot SMB + h \cdot HML \quad (11)$$

were *SMB* – the difference between the returns of companies with large and small capitalization;  
*HML* – the difference between the returns of companies with low and high intrinsic value (*indicator B/P*).

#### *Fama-French Five-factor Model*

The equation of Fama-French five-factor model (Fama and French, 1993, 1995) in addition to the difference between the returns of companies with large and small capitalization (*SMB*) and the difference between the returns of companies with low and high intrinsic value (*indicator B/P*)(*HML*) accounts return on equity and company capital expenditure and has a view

$$k_e = k_f + \beta_U(k_m - k_f) + s \cdot SMB + h \cdot HML + r \cdot RMW + c \cdot CMA, \quad (12)$$

where *RMW* – return on equity; *CMA* – company capital expenditure.

**Arbitrage Pricing Theory (APT)**

In the Arbitrage Pricing Theory (APT model), the return on an asset can be expressed by the following formula:

$$r_i = a_i + \beta_{i1}F_1 + \beta_{i2}F_2 + \dots + \beta_{in}F_n + \varepsilon_i, \tag{13}$$

where  $a_i$  is a constant per asset;  $F_i$  is a systematic factor, such as a macroeconomic or company-specific factor;  $\beta_i$  is the sensitivity of the asset in relation to the factor  $F_i$ ; and  $\varepsilon_i$  is a random variable with an expected mean of zero.

APT formula has the form:

$$E(r_i) = r_f + \beta_{i1}\hat{F}_1 + \beta_{i2}\hat{F}_2 + \dots + \beta_{in}\hat{F}_n, \tag{14}$$

where  $r_f$  is the risk-free rate of return,  $\beta_{ik}$  is the sensitivity of the asset  $i$  with respect to factor  $k$ ,  $\hat{F}_k$  is the risk premium for factor  $k$ .

In opposite to the CAPM, which has only one factor and one beta, the APT formula has multiple factors that include non-company factors, which requires the asset's beta with respect to each separate factor. The APT does not explain what these factors are, and APT model users should analytically determine factors that might affect the asset's returns. The factor used in the CAPM is the difference between the market rate of return and the risk-free rate of return.

The CAPM is a one-factor model and is simpler to use, thus investors prefer use it to estimate the expected rate of return rather than using APT, which requires users value the multiple factors.

Below we describe a couple more modifications of CAPM, which account the business and financial risks.

**ACCOUNT OF BUSINESS AND FINANCIAL RISKS**

Two models - Hamada model, by R. Hamada (1961) and CAPM 2.0 model, by Brusov–Filatova–Kulik (2023) account the business and financial risks. The first author did this phenomenologically, and the second authors - analytically. Below we describe both these theories in details and compare their results, showing that Hamada results are incorrect.

**Hamada Model**

The Modigliani–Miller theory with taxes (Modigliani and Miller, 1963) has been united with CAPM (Capital asset pricing model) in 1961 by R. Hamada. For the cost of equity of a leveraged company, the below formula has been derived.

$$k_e = k_f + \beta_U(k_m - k_f) + \beta_U(k_m - k_f)\frac{D}{S}(1-t) \tag{15}$$

The first term represents risk-free profitability  $k_f$ , the second term is business risk premium,  $\beta_U(k_m - k_f)$ , and the third term is financial risk premium  $\beta_U(k_m - k_f)\frac{D}{S}(1-t)$ .

In the case of an unlevered company ( $D = 0$ ), the financial risk (the third term) is zero, and its shareholders receive only a business risk premium.

Hamada used an empirical approach in incorporating the level of leverage into the CAPM. One of the main objectives in his research was to distinguish companies without leverage from companies with leverage. The latter make up almost the majority of real companies. In 1972, he surveyed 304 companies, among which he found 102 non-leveraged and 202 leveraged (Hamada 1972). Comparing equity returns of two types of companies, he got his formula for the  $\beta_U$ -factor, which takes into account the level of leverage.

The incorrectness of the Hamada approximation will be shown below in the framework of the new approach **CAPM 2.0**, which has been developed by by Brusov–Filatova–Kulik (2023), which account both business and financial risk.

**CAPITAL ASSET PRICING MODEL 2.0 (CAPM 2.0)**

In this section, we describe a new approach that describes both business and financial risk. We call this approach CAPM 2.0. (Brusov–Filatova–Kulik 2023), as opposed to conventional CAPM, which accounts only business risk.

**Derivation of the Main Formula CAPM 2.0**

Let's combine CAPM (Capital asset pricing model) and the Modigliani–Miller theory (Modigliani and Miller 1963) not phenomenologically, like Hamada (1969, 1972), but analytically.

Substituting the CAPM formula

$$k_0 = k_f + \beta_U(k_m - k_f) \tag{16}$$

into Modigliani–Miller formula for equity cost

$$k_e = k_0 + L(k_0 - k_d)(1-t), \tag{17}$$

one gets the following result

$$\begin{aligned} k_e &= k_0 + L(k_0 - k_d)(1-t) = \\ &= k_f + \beta_U(k_m - k_f) + L(k_f + \beta_U(k_m - k_f) - k_d)(1-t) = \\ &= k_f(1 + L(1-t)) + \beta_U(k_m - k_f)(1 + L(1-t)) - Lk_d(1-t) \end{aligned} \tag{18}$$

The second term is the same as in Hamada's formula (15), but the first term is renormalized value of risk free profitability and the last term, which depends on the cost of debt  $k_d$ , is missing from Hamada's formula (15).

So the difference with Hamada's formula is:

while in Hamada's formula only beta coefficient is renormalized, in formula (18) the first term (risk–free return) is also renormalized by the same factor  $(1 + L(1-t))$  and the last term, depending on the cost of debt  $k_d$ , appears, which is absent in Hamada's formula.

Factor  $(1-t)$  (tax corrector) exists due to the tax shield.

The incorrectness of Hamada's approximation becomes obvious.

We could rewrite expression (8) as a sum of two parts, one of which is the Hamada expression, and the second is an additional term that we received

$$\begin{aligned} k_e &= k_f + \beta_U(k_m - k_f)(1 + L(1-t)) + k_f L(1-t) - Lk_d(1-t) = \\ &= k_f + \beta \cdot (k_m - k_f) + L(1-t)(k_f - k_d) = k_{e,CAPM} + \Delta \end{aligned} \tag{19}$$

Here

$$\Delta = L(1-t)(k_f - k_d). \tag{20}$$

This formula takes into account both business and financial risk and is the main result of the work. Below in section 4 we will apply developed by us approach to several companies, calculate their profitability using formula (9) and compare the results with conventional CAPM that take into account only business risks (with some notes).

From the formula (20) it follows, that the value added to the company's return ( $\Delta$ ) with respect to results of conventional CAPM does not depend on the industry (see below) or market version of CAPM and turns out to be the same for both cases.

**INDUSTRY APPROACH**

CAPM has an alternative approach that refers to the industrial index rather than the market.

$$k_i = k_f + \beta_i(k_I - k_f). \tag{21}$$

Here,  $k_f$  is risk free profitability,  $\beta$  is the  $\beta$ -coefficient of the company. In this case it shows the dependence of the return on the asset and the return on the industry as a whole. The  $\beta$ -coefficient now is described by the following formula

$$\beta_i = \frac{\text{COV}_{il}}{\sigma_i^2} = \rho_{il} \frac{\sigma_i}{\sigma_I} \quad (22)$$

Here  $\sigma_i$  is the risk of  $i$ -th asset,  $\sigma_I$  is industry risk (standard deviation of industry index),  $\text{COV}_{il}$  is covariance between  $i$ -th asset and industry index. Note, that the industry approach better describes the return on an asset than the market approach.

### METHODOLOGY AND FEATURES OF THE APPLICATION OF THE NEW APPROACH (CAPM 2.0)

It is clear that the vast majority of companies are leveraged ones because they use debt financing. The use of debt financing is determined by several factors.

1. All listing companies are quite large and participate in expanded reproduction, which requires the attraction of borrowed capital.
2. The use of debt financing allows you to take advantage from the tax shield: reduce the cost of capital raised and increase the company value.

This means that the standard CAPM formula takes into account business risk and part of the financial risk accounted for by the leveraged beta coefficient in the form of Hamada. This reduces the importance of Hamada's formula, since the covariance found from the statistical reporting and Beta-coefficient already contains the level of leverage and does not need to be renormalized. While the additional term(s) found by us must be taken into account in order to correctly determine the premium for financial risk.

If we consider the almost never occurring case of a non-leveraged company, then we need to apply the standard CAPM formula with a non-leveraged beta. However, if we want to make a forecast for assessing the profitability of the company, taking into account the future level of leverage, it is necessary to take into account all three of the above additives related to taking into account debt financing.

### APPLICATION OF CAPM 2.0 APPROACH TO

The application of the new approach is carried out through the following steps:

- **At the first stage**, it is necessary to collect and process statistical data at three levels: company, industry and market. We need the following parameters:

- 1) For company  $k_i; L; k_d; \sigma_i; \beta_{il}; \beta_{im};$
- 2) For industry  $k_I; L; k_d; \sigma_I; \beta_{il};$
- 3) Market  $k_m; \sigma_m; \beta_{im}$

Here  $k_i; k_I; k_m$  stand for company, industry and market returns;

$\sigma_i; \sigma_I; \sigma_m$  are standard deviation for company, industry and market returns;

$\beta_{il}; \beta_{im}$  are beta coefficient company to industry and to market;

L is leverage level;  $k_d$  is the cost of debt.

It is also necessary to use methods for their processing, since we will operate with average annual values, and the data on the sites usually give daily quotes.

- **At the second stage** we evaluate the company's profitability within the traditional CAPM.
- **At the third stage** one needs to use formulas (19) and (20) to estimate the company return under taking into account both business and financial risk.
- **At the fourth stage**, the company's profitability is compared on the traditional CAPM approach and on the new CAPM 2.0 approach.

**Application of the New CAPM 2.0 Approach to Walt Disney Company**

Below we provide an example of applying the new CAPM 2.0 approach to the Walt Disney Company and comparing it with the results of the classic CAPM.

Estimation of the return of Walt Disney Company: DIS for the period 2018–2022 by CAPM

Summary of indicators for Walt Disney Company: DIS shares, industry an market indexes in the period 2018–2022 could be found in Table 1.

Table 1. Summary table of indicators for Walt Disney Company: DIS shares, industry (SPLRCD) and market (S&P500) indexes in the period 2018–2022

Level	Index	2018	2019	2020	2021	2022
Company	$k_i$	1.99%	31.90%	25.27%	-14.51%	-43.91%
	$\sigma_i$ (ΠΟ μ)	0.041	0.088	0.132	0.069	0.108
	$L_i$	0.43	0.53	0.70	0.61	0.51
	$k_d$	3.27%	2.65%	2.81%	2.84%	3.20%
	$\beta_{im}$	0.57	0.93	1.54	1.23	1.18
Industry (SPLRCD)	$k_I$	-0.49%	26.20%	32.07%	23.66%	-37.58%
	$\sigma_I$ (ΠΟ μ)	0.057	0.046	0.090	0.041	0.089
	$L_I$	0.20	0.20	0.15	0.15	0.33
	$\beta_{iI}$	0.355	0.695	1.081	0.049	0.816
	$k_i$	1.78%	18.94%	34.55%	2.96%	-29.94%
Market (S&P500)	$k_m$	-6.24%	28.88%	16.26%	26.89%	-19.44%
	$\sigma_m$	0.044	0.037	0.075	0.032	0.066
	$\beta_{im}$	0.57	0.93	1.54	1.23	1.18
	$k_F$	3.020%	2.389%	1.646%	1.905%	3.975%
	$k_i$	-2.28%	27.13%	24.14%	32.61%	-23.64%
	$k_i$ , Company	1.99%	31.90%	25.27%	-14.51%	-43.91%
	$k_i$ , Industry	1.78%	18.94%	34.55%	2.96%	-29.94%
	$k_i$ , Market	-2.28%	27.13%	24.14%	32.61%	-23.64%

Table 2. Comparison of Walt Disney Company: DIS shares profitability estimates for the period 2018–2022 on CAPM and on the new CAPM 2.0 approach

Year	2018	2019	2020	2021	2022
$k_F$	3.02 %	2.39 %	1.646%	1.91 %	3.98 %
$\Delta$	-0.08%	-0.11 %	-0.64%	-0.45%	0.31%
$k_i$ , Company	1.99%	31.90%	25.27%	-14.51%	-43.91%
$k_i$ , Industry	1.78%	18.94%	34.55%	2.96%	-29.94%
$k_i$ , Market	-2.28%	27.13%	24.14%	32.61%	-23.64%
<b><math>k_i</math> CAPM (Industry)</b> New CAPM 2.0 approach	1.70%	18.83%	33.91%	2.51%	-29.63%
<b><math>k_i</math> CAPM (market)</b> New CAPM 2.0 approach	-2.36%	27.02%	23.50%	32.16%	-23.33%

From Tables 1–2 and from results for other dozens companies we come to the following conclusions:

1. When  $k_d$  exceeds  $k_f$ , the financial risk premium becomes negative.
2. As well for companies from the extractive industries, such as Rosneft etc, whose leverage level, due to the specifics of the industry is quite high, the premium for financial risk is high as well.
3. At the same time, companies with a typical level of leverage from 0.5 to 1 (1.5) have a low financial risk premium compared to a business risk. This is well seen for Walt Disney Company (L is of order 0.5) and for Pfizer INC. (L is of order 1–1.5).

### CONCLUSIONS

A comprehensive analysis of CAPM (Capital Asset Pricing Model) was carried out. Our analysis within CAPM for several dozen listed companies from different countries, as well as numerous results of other authors, showed that the CAPM results differ significantly from the real returns of companies. The reasons for this discrepancy have been discussed, which are related to the internal properties and shortcomings of the model, as well as its possible modifications that can bring the model closer to real life. Among the latter, accounting for financial risk in CAPM along with business risk, various amendments such as the Fama–French corrections, Arbitrage Pricing Theory (APT) and the incorporation of CAPM into modern capital structure theories. Two versions of CAPM (market and industry) are considered and it is shown that the latter is closer to real life. Accounting for financial risk in CAPM along with business risk was made by Brusov, Filatova and Kulik recently analytically (CAPM 2.0 model), in contrast to the phenomenological model of Hamada, and a large difference in these results was emphasized. In addition to the renormalization of the beta-coefficient, obtained in the Hamada model, two additional terms are found: the renormalized risk-free return and the term dependent on the cost of debt  $k_d$ . Disadvantages of Hamada's model have been discussed. From Tables 1–2 and from results for other dozens companies we come to the following conclusions:

1. When  $k_d$  exceeds  $k_f$ , the financial risk premium becomes negative.
2. As well for companies from the extractive industries, such as Rosneft etc, whose leverage level, due to the specifics of the industry is quite high, the premium for financial risk is high as well.
3. At the same time, companies with a typical level of leverage from 0.5 to 1 (1.5) have a low financial risk premium compared to a business risk. This is well seen for Walt Disney Company (L is of order 0.5) and for Pfizer INC. (L is of order 1–1.5).

It has been shown, that the value added to the company's return ( ) within CAPM 2.0 model with respect to results of conventional CAPM does not depend on the industry or market version of CAPM and turns out to be the same for both cases. The results obtained show that accounting for financial risk properly significantly affects the assessment of the return on assets. The proposed approach allows making forecasts on the company's profitability without using the theory of capital structure. Estimated financial risk premiums depend on the level of leverage (capital structure) and the cost of borrowings. By planning the values of these parameters, the manager can predict the profitability of the company in the future. The novelty of the CAPM 2.0 model lies in the development of a new approach that generalizes CAPM to account for both business and financial risks.

One of the directions of future investigation is the incorporation of CAPM into modern capital structure theories: Brusov–Filatova–Orekhova theory and the Modigliani–Miller (MM) theory.

### Abbreviations

**CAPM:** Capital Asset Pricing Model; **MM:** the Modigliani – Miller theory;  $k_i; k_l; k_m$  ( ; ; m) stand for company, industry and market returns;  $\sigma_i; \sigma_l; \sigma_m$  are standard deviation for company, industry and market returns;  $\beta_{il}; \beta_{im}$  are Beta coefficients company to industry and to market; L is leverage level;  $k_d$  is the cost of debt.

### REFERENCES

- Blattberg, R.C. & Gonedes, N.J. (1974). A comparison of the stable and student distributions as statistical models for stock prices. *J. Bus.*, 47, 244–280.
- Brusov Peter and Filatova Tatiana (2023). Capital Structure Theory: Past, Present, *Future Mathematics* 2023, 11(3), 616; <https://doi.org/10.3390/math11030616>
- Brusov Peter, Filatova Tatiana, Kulik Veniamin (2023). Capital Asset Pricing Model 2.0: account of business and financial risk, Preprint ID: 87056; DOI10.20944/preprints202310.0347.v1
- Brusov, P., Filatova, T., Orekhova, N. (2022). Generalized Modigliani–Miller Theory: Applications in Corporate Finance, Investments, Taxation and Ratings, Springer Nature, 362 pp
- Brusov, P., Filatova, T., & Orekhova N., (2023). The Brusov–Filatova–Orekhova Theory of Capital Structure: Applications in Corporate Finance, Investments, Taxation and Ratings, Springer Nature, 769 pp.



- Chen, J., Wu, Y., Xu, Y. (2021). Research and analysis of asset pricing model based on the empirical test of stock price. In Proceedings of the Third International Conference on Economic Management and Cultural Industry, Guangzhou, China, 22–24 October 2021; pp. 1288–1293.
- Fama, E.F. & French, K. R. (1992). The Crosssection of Expected Stock Returns, *The Journal of Finance*, 47(2): 427–465
- Fama, E. F. & French, K. R. (1993). Common Risk Factors in the Returns on Stocks and Bonds, *Journal of Financial Economics*, 33(1): 3–56
- Fama, E. F., & French, K. R. (1995). Size and Book-to-market Factors in Earnings and Returns. *The Journal of Finance*, 50(1): 131–155.
- Fama, E.F. (1965) The behavior of stock–market prices. *J. Bus.*, 38, 34–105.
- French, Craig W. (2003). The Treynor Capital Asset Pricing Model. *Journal of Investment Management*, Vol. 1, No. 2, pp. 60–72, Available at SSRN: <https://ssrn.com/abstract=447580>
- Hamada, R. (1969). Portfolio Analysis, Market Equilibrium, and Corporate Finance. *J. Finance*, 24, 13–31
- Hamada, R. (1972). The Effect of the Firm’s Capital Structure on the Systematic Risk of Common Stocks, *The Journal of Finance*, 435–452
- Lange, K.L.; Little, R.J., & Taylor, J.M. (1989). Robust statistical modeling using the t distribution. *J. Am. Stat. Assoc.*, 84, 881–896.
- Leal Danilo, Rodrigo Jiménez, Marco Riquelme & Víctor Leiva (2023). Elliptical Capital Asset Pricing Models: Formulation, Diagnostics, Case Study with Chilean Data, and Economic Rationale Mathematics, 11(6), 1394; <https://doi.org/10.3390/math11061394>
- Lintner J. (1965). The valuation of Risk Assets and the selection of Risky Investments in Stock Portfolios and Capital Budgets. *Review of Economics and Statistics*, 13–37.
- Modigliani, F. & Miller, M.H. (1958). The cost of capital, corporation finance and the theory of investment. *Am. Econ. Rev.* 48, 261–296.
- Modigliani, F., Miller, M.H. (1963). Corporate income taxes and the cost of capital: A correction. *Am. Econ. Rev.* 53, 433–443.
- Mossin J. (1966). Equilibrium in a Capital Asset Market, *Econometrica*, 768–783.
- Ross, Stephen The arbitrage theory of capital asset pricing. *Journal of Economic Theory*. 13(3): 341–360. doi:10.1016/0022-0531(76)90046-6.
- Sharpe, W. F. (1964). Capital Asset Prices: A Theory of Market Equilibrium under Conditions of Risk. *The Journal of Finance*, 19(3), 425–442.
- Sigman Karl. (2005). CAPM for economics.
- Treynor, Jack L. (1965). How to evaluate the management of investment funds. *Harvard Business Review*, 43, p. 63–75.
- Zhou, G. (1993). Asset–pricing tests under alternative distributions. *J. Financ.*, 48, 1927–1942.

## Cold Chain Logistics Risk Analysis Based on AHP-FCE Method

Zhongming Nie <sup>1,\*</sup>  
Kun Tian <sup>2</sup>

\*Corresponding author

<sup>1</sup> Associate Professor, Wuhan Polytechnic, Wuhan, China, [30758119@wtc.edu.cn](mailto:30758119@wtc.edu.cn)

<sup>2</sup> Associate Professor, Wuhan Business University, Wuhan, China, [tiank@wbu.edu.cn](mailto:tiank@wbu.edu.cn)

### ABSTRACT

This paper utilizes the Supply Chain Operational Reference method to identify and analyze risk indicators in cold chain logistics. It establishes a model based on the Analytic Hierarchy Process (AHP) and Fuzzy Comprehensive Evaluation (FCE) method. The model is validated using a fresh food supermarket in Wuhan, China as a sample. The results indicate that procurement and supply risk ranks highest among the various risks in the cold chain of the supermarket, followed by information technology risk, planning process risk, return process risk, production process risk, and distribution process risk. In response to each risk factor, corresponding countermeasures and suggestions are proposed.

*Keywords:* cold chain logistics; risk factors; AHP-FCE method; fresh food supermarket

### INTRODUCTION

With the continuous development of the economy, there has been a significant improvement in residents' living standards and consumption abilities. In addition, there is a growing awareness of health consciousness, leading to an increased demand for fresh food products. Fresh food supermarkets' cold chain systems play a crucial role in ensuring the freshness of various products, preserving their nutrients, and minimizing losses during transportation. This, in turn, helps to reduce costs and increase profits. Therefore, it is imperative to establish a practical and effective risk identification system for the supply chain of fresh food products and continuously conduct research on the risks associated with these products. This study aims to analyze the current situation of cold chain logistics development in China, conduct a comprehensive analysis of the risks present in the supply chain of fresh food products, and utilize the Analytic Hierarchy Process (AHP) and Fuzzy Comprehensive Evaluation (FCE) methods to identify and evaluate the risk factors associated with fresh food products. The ultimate goal is to promote the development of cold chain logistics in China and expand the market for fresh food products.

### RESEARCH OBJECTS AND TOOLS

#### Cold Chain Logistics in China

Cold chain logistics in China is the main focus of this study. Cold chain logistics refers to a specialized circulation method that includes pre-cooling at the origin, cold storage and transportation, distribution, and retailing to ensure the quality and safety of perishable products. In recent years, China's agricultural cold chain logistics has witnessed significant development, with notable improvements in technology, optimized structure and layout, and increasing strength of the industry's stakeholders. This progress can be attributed to factors such as domestic consumption upgrading, agricultural high-quality development, industry endogeneity, external environment, changing consumer demands, advancements in industrial technology, and government policies.

According to statistics from the Ministry of Agriculture and Rural Affairs (2021), approximately 1,800 counties, 7,000 townships, and 220,000 villages in China have implemented cold chain logistics construction projects. More than 520,000 facilities are under construction, leading to an increase in new refrigerated storage capacity by 12 million tons or more. Between 2014 and 2021, the cold storage capacity in China grew from 32.95 million tons to 74.98 million tons, with an average annual growth rate of 73%. Additionally, the number of refrigerated vehicles increased from 760,000 to 3.41 million during the same period, with an average annual growth rate of 23%.

Despite the significant development in China's agricultural cold chain logistics, there still exists a considerable gap when compared to industrial demand due to a relatively late start. Various challenges hinder the efficient utilization of cold chain logistics, including high investment costs in construction, technological adoption barriers, expensive operational costs, challenges related to seasonal and geographical characteristics, specialization of cold chain facilities, and inconsistencies and lack of coordination in the development of cold chain logistics standards.

#### Supply Chain Operations Reference Model (SCOR)

The Supply Chain Operations Reference (SCOR) model is a tool developed by the Supply Chain Council. This model is used for mapping, benchmarking, and configuring supply chain operations (Zhou, 2011). It provides a framework that is organized around five management processes: Plan, Source, Make, Deliver, and Return. These processes are further broken down into process categories, elements, tasks, and activities (Karimi *et al.*, 2019). SCOR is widely recognized as the de facto standard in both academic and industry settings within the field of supply chain management (Chen & Feng, 2007). It is considered highly valuable for strategic decision-making and rigorous supply chain performance evaluation.

According to Xiang (2019), SCOR allows companies to analyze the configuration of their supply chains and identifies and eliminates redundant and inefficient practices along the supply chain. It serves as a business process architecture, defining how these processes interact, perform, and are configured from the supplier's supplier to the customer's customer (Supply Chain Council, 2010; Zhang, 2018; Shao et al., 2019).

### **The Analytic Hierarchy Process (AHP)**

The Analytic Hierarchy Process (AHP), introduced by Thomas Saaty (1986), is a valuable tool for handling complex decision-making processes and assisting decision-makers in setting priorities and making optimal decisions. This method breaks down complex decisions into a series of pairwise comparisons, allowing for the synthesis of results that consider both subjective and objective aspects of the decision. The AHP also incorporates a technique to assess the consistency of evaluations made by the decision-maker, thereby reducing bias in the decision-making process.

Narayanan (2019) applied the AHP to identify, model, analyze, and prioritize barriers to implementing sustainable practices in the rubber products manufacturing industry in Kerala, South India. Al-Aomar and his colleagues (2019) developed a framework using the AHP to identify, categorize, and prioritize lean techniques adopted in a hotel supply chain. Additionally, Bahurmoz (2006) identified eight effective elements of resilience capacities that contribute to the resilience of suppliers.

### **Fuzzy Comprehensive Evaluation (FCE) Method**

The Fuzzy Comprehensive Evaluation (FCE) method is a comprehensive evaluation approach based on fuzzy mathematics. This method converts quantitative evaluations into qualitative evaluations by utilizing the membership degree theory of fuzzy mathematics. FCE evaluates changes in membership degrees and assesses objects based on multiple criteria (Zadeh, 1985). It considers both the object's level and the impact of fuzzy factors, allowing for the reflection of evaluation criteria. Furthermore, FCE incorporates people's experiences, resulting in more objective and realistic evaluation outcomes. By combining qualitative and quantitative factors, FCE expands the amount of information and assesses the credibility of conclusions drawn. Additionally, it effectively addresses fuzzy and difficult-to-quantify problems (Zhang, 2018). Hence, the FCE method is suitable for solving various non-deterministic problems.

The FCE method utilizes fuzzy transformation and the maximum degree of membership principle (Zadeh, 1985). Firstly, it employs fuzzy sets to represent the various factors associated with the evaluation object. Secondly, it calculates the evaluation matrix and the weights of evaluation factors. Lastly, a fuzzy linear transformation is employed to determine the evaluation results in terms of fuzzy sets. This method is particularly useful for tackling complex and uncertain problems involving multiple factors.

## **RISK IDENTIFICATION**

From a supply chain perspective, the e-commerce cold chain logistics for fresh food products involves various nodes and relies on the coordination and cooperation of all members in the supply chain network. This complexity introduces multiple sources of risk to the fresh produce e-commerce cold chain logistics. Furthermore, the probability of risk occurrence, degree of loss, and uncertainties in time and location increase the difficulty in managing cold chain logistics risks. Liu (2018) highlighted that external risks in fresh e-commerce cold chain logistics are related to market demand, environment, and policies, while internal risks are linked to procurement and supply, technology, and human resources. Pan and Chen (2020) identified cold chain logistics risks such as technology risk, equipment risk, cooperation risk, information integration risk, and environmental risk, and proposed corresponding control measures. Zhang and He (2019) analyzed cold chain logistics risks of fresh agricultural products from the perspectives of storage, sorting, transportation, and others. They found that transportation risk had the highest level, followed by sorting and other risks, and storage risk had the lowest level. Considering existing research on cold chain logistics risk and the structure of fresh produce e-commerce supply chains, this paper synthesizes a substantial amount of risk literature and presents an analysis and modeling of cold chain risks in a fresh food supermarket based on the SCOR model. The proposed analysis focuses on six dimensions: planning process risk, information technology risk, production process risk, procurement supply risk, distribution process risk, and return process risk.

### **Planning Process Risk**

To ensure the relatively stable development of fresh produce supermarkets, it is imperative to plan each link comprehensively. This entails forecasting market demand and formulating an overarching supply chain strategic plan that aligns with the supermarket's current business condition. It is important to note that price fluctuations in the market can significantly impact consumer demand and purchasing power, leading to adjustments in the supermarket's original purchasing plan.

### **Information Technology Risk**

Insufficient investment in science and technology has resulted in an imperfect information-sharing mechanism and a low utilization rate of modern information technology. As a consequence, there are delays and difficulties in transmitting and sharing information, which introduces risks such as information distortion and lagging. Additionally, due to information asymmetry, when the market experiences significant fluctuations, nodal enterprises within the supply chain may prioritize profit maximization at the expense of ethical principles, engaging in practices of concealment and misrepresentation. This not only poses a threat to the interests of the overall supply chain but also has the potential to disrupt the entire supply chain.

### **Production Process Risk**

The fresh produce supply chain is growing increasingly complex due to consumers' rising demand for quality and high-end fruits and vegetables. Meeting the ever-changing needs of consumers has become a challenge, as their preferences indirectly influence the planting and procurement plans of supermarkets. Moreover, biased national policies and regulations can result in significant fluctuations in the supply of a particular product, potentially leading to overproduction or oversupply issues. This further adds to the complexity of the supply chain and poses risks for stakeholders involved in the fresh produce industry.

### **Procurement Supply Risk**

The production of fresh produce is indeed susceptible to factors such as temperature and humidity. When production exceeds demand, market prices tend to rise, which can have an impact on the purchasing plans of supermarket buyers. Furthermore, product quality, pesticide residue, and freshness are crucial factors that influence consumer purchasing decisions. Any issues related to these aspects can increase procurement and supply chain risks. Additionally, the improper selection of suppliers within the supply chain can directly disrupt the procurement process, leading to supply chain breakdown. Therefore, it is essential to carefully evaluate and choose reliable suppliers to maintain the smooth functioning of the supply chain for fresh produce.

### **Distribution Process Risk**

Fresh products, being perishable in nature, require proper packaging to avoid damage during transportation. Failure to package them appropriately can result in crushing and collision, leading to a decline in product quality. Moreover, if the transportation distance is too long, there is a higher risk of untimely delivery, which can further increase the chances of loss or spoilage of agricultural products during transit.

### **Risk of the Return Process**

In cases where the transportation of fresh produce is mishandled, leading to deterioration or loss, there may be a need for product returns. If the after-sales personnel fails to handle these returns properly, it can indeed result in increased consumer dissatisfaction and, subsequently, impact their purchasing power. Customer satisfaction is crucial for maintaining a positive brand image and fostering repeat purchases. To mitigate these issues, it is essential for after-sales personnel to handle returns efficiently and effectively. This includes ensuring proper communication, timely resolution, and compensatory measures when necessary. By addressing customer concerns professionally, businesses can maintain customer satisfaction and retain their purchasing power.

## **HIERARCHICAL RISK ANALYSIS MODEL UNDER SCOR**

### **Constructing the Hierarchical Model**

After conducting the aforementioned analysis of risk factors in the fresh food cold chain, we have determined the hierarchical relationship and constructed a hierarchical structure. There are six primary indicators in this hierarchical model, namely, B<sub>1</sub> planning process risk, B<sub>2</sub> information technology risk, B<sub>3</sub> production process risk, B<sub>4</sub> procurement and supply risk, B<sub>5</sub> distribution process risk, and B<sub>6</sub> return process risk. These primary indicators are then followed by 18 secondary indicators, which are as follows: B<sub>1-1</sub> improper market demand forecast, B<sub>1-2</sub> inconsistent strategic objectives, B<sub>1-3</sub> market price fluctuation, B<sub>2-1</sub> information asymmetry, B<sub>2-2</sub> supply chain informationization, B<sub>2-3</sub> information distortion, B<sub>3-1</sub> policies and regulations, B<sub>3-2</sub> natural disasters, B<sub>3-3</sub> consumer demand preferences, B<sub>4-1</sub> high procurement prices, B<sub>4-2</sub> improper supplier selection, B<sub>4-3</sub> product quality problems, B<sub>5-1</sub> outdated transportation equipment, B<sub>5-2</sub> long transportation distances, B<sub>5-3</sub> improper product packaging, B<sub>6-1</sub> untimely delivery, B<sub>6-2</sub> deterioration and loss of agricultural products, and B<sub>6-3</sub> Personnel's business processing ability. See Figure 1:

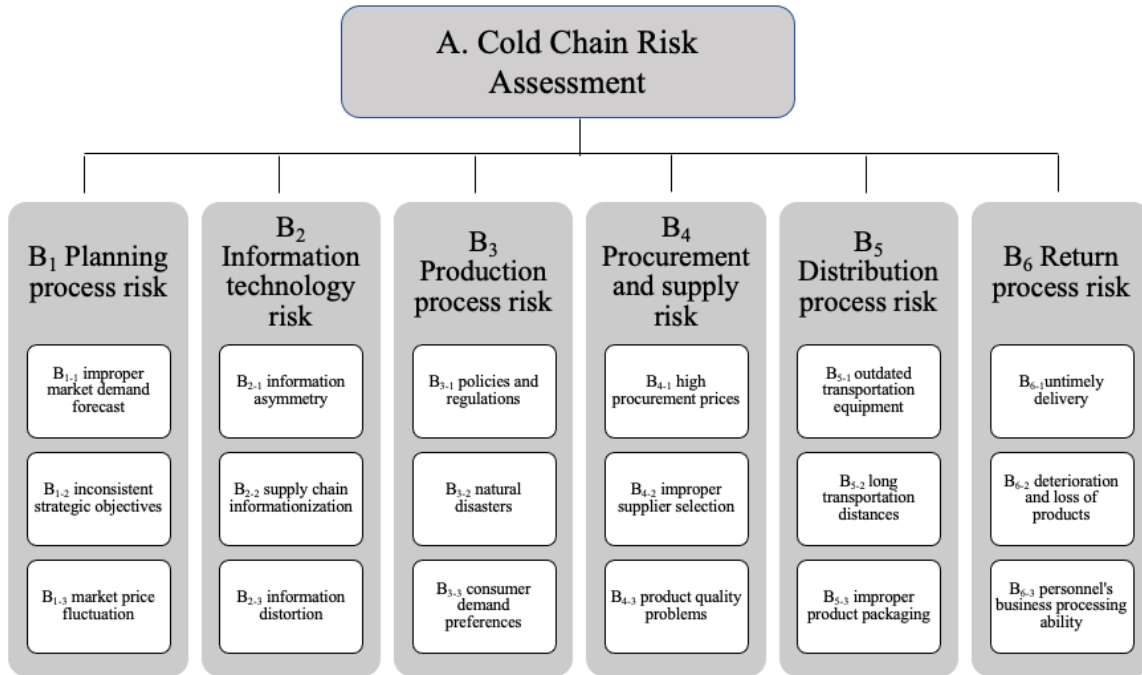

Figure 1 : Hierarchical model of cold chain risk assessment

**Constructing the judgment matrix**

The following comparison matrix is constructed based on the statistical literature and the judgment information from the literature of experts in related fields, and the weights of the influencing factors of its indicators at all levels are calculated. The determination of the weight values requires importance scales, and the scales of the judgment matrix, as in Table 1.

Table 1 Scale of Importance

Factor <i>m</i> & <i>n</i>	Value
Equally important	1
Slightly important	3
Obviously important	5
Much more important	7
Extremely important	9
Median values of continuous judgements	2, 4, 6, 8

Assuming the target layer is A, the criterion layer is B<sub>i</sub>, and the sub-criterion layer is B<sub>ij</sub>, the judgment matrix of each factor is obtained as follows:

$$A = \begin{vmatrix} 1 & 3 & 2 & 1/4 & 2 & 1/4 \\ 4 & 5 & 3 & 1 & 3 & 1 \\ 1/2 & 2 & 1 & 1/3 & 1 & 1/3 \\ 1/3 & 1 & 1/2 & 1/5 & 1/2 & 1/5 \\ 4 & 5 & 3 & 1 & 2 & 1 \\ 1/2 & 2 & 1 & 1/2 & 1 & 1/3 \end{vmatrix}$$

$$B_1 = \begin{vmatrix} 1 & 2 & 5 \\ 0.5 & 1 & 3 \\ 0.2 & 0.33 & 1 \end{vmatrix} \quad B_2 = \begin{vmatrix} 1 & 2 & 0.25 \\ 0.5 & 1 & 1/3 \\ 4 & 3 & 1 \end{vmatrix} \quad B_3 = \begin{vmatrix} 1 & 0.33 & 0.25 \\ 3 & 1 & 0.5 \\ 4 & 2 & 1 \end{vmatrix}$$

$$B_4 = \begin{vmatrix} 1 & 0.5 & 0.25 \\ 2 & 1 & 0.33 \\ 4 & 3 & 1 \end{vmatrix} \quad B_5 = \begin{vmatrix} 1 & 0.25 & 0.33 \\ 4 & 1 & 2 \\ 3 & 0.5 & 1 \end{vmatrix} \quad B_6 = \begin{vmatrix} 1 & 0.5 & 3 \\ 2 & 1 & 4 \\ 0.33 & 0.25 & 1 \end{vmatrix}$$

**Weight vector and consistency index**

According to the above judgment matrix at all levels, firstly, the column vector is integrated and calculated to derive the standard judgment matrix; in the row and normalization, the index weights W at all levels are derived; then the eigenvalues  $\lambda_{max}$  of each index are calculated; finally, the consistency index CI and consistency rate CR are calculated, and the consistency judgment is made.

Table 2 Calculation results of each indicator

Indicator	W	$\lambda_{max}$	CI	RI	CR	Consistency judgment
A	[0.1293, 0.3223, 0.0941, 0.0524, 0.3013, 0.1006]	6.1997	0.0399	1.25	0.032	Passed
B <sub>1</sub>	[0.5816, 0.309, 0.1095]	3.0037	0.0018	0.525	0.0035	Passed
B <sub>2</sub>	[0.1365, 0.2385, 0.625]	3.0183	0.0091	0.525	0.0174	Passed
B <sub>3</sub>	[0.122, 0.3196, 0.5584]	3.0183	0.0091	0.525	0.0174	Passed
B <sub>4</sub>	[0.1365, 0.2385, 0.625]	3.0183	0.0091	0.525	0.0174	Passed
B <sub>5</sub>	[0.122, 0.5584, 0.3196]	3.0183	0.0091	0.525	0.0174	Passed
B <sub>6</sub>	[0.3196, 0.5584, 0.122]	3.0183	0.0091	0.525	0.0174	Passed

**Analysis of results**

The data in Table 2, suggests that the CR of the consistency test of indicators at all levels is less than 0.1, which means that the indicators at all levels satisfy the consistency test. From the above weights, it can be seen that B<sub>2</sub> has the largest weight (0.3223), followed by B<sub>5</sub> (0.3013), B<sub>1</sub> (0.1293), B<sub>6</sub> (0.1006), B<sub>3</sub> (0.0914), and B<sub>4</sub> (0.0524) in order. Among the secondary indicators, B<sub>1-1</sub> (0.5816) has the greatest impact on the planning process risk, followed by B<sub>1-2</sub> (0.309) and B<sub>1-3</sub> (0.1095); among the IT risks, the most important is B<sub>2-3</sub> (0.625), followed by B<sub>2-2</sub> (0.2385) and B<sub>2-1</sub> (0.1365); among the production process risks, B<sub>3-3</sub> (0.5584) is the key factor in production process risk, much higher than B<sub>3-1</sub> (0.122) and B<sub>3-2</sub> (0.3196); in procurement supply risk, B<sub>4-3</sub> (0.625) is the key factor affecting procurement supply risk, much higher than B<sub>4-2</sub> (0.2385) and B<sub>4-1</sub> (0.1365); in distribution process risk, B<sub>5-2</sub> (0.5584) is more important than B<sub>5-1</sub> (0.122) and B<sub>5-3</sub> (0.3196) in distribution process risk; and finally in return process risk, B<sub>6-2</sub> (0.5584) is more important than B<sub>6-1</sub> (0.3196) and B<sub>6-3</sub> (0.122).

**FUZZY COMPREHENSIVE EVALUATION**

**Establishing the factor sets**

According to the model of the risk assessment index system, several experts in the field of cold chain logistics were invited to rate the risks of the fresh food supermarket at all levels and establish a fuzzy comprehensive evaluation matrix, and finally determine the risk level domain: V = (very safe, safe, generally safe, generally dangerous, dangerous, very dangerous), and the corresponding scores are 1, 2, 3, 4, 5, 6, where the higher the score indicates the possibility of risk occurrence. The higher the score is, the greater the possibility of risk will be. The evaluation matrix of the above six secondary indicators can be obtained as follows:

$$\begin{aligned}
 Y_{B1} &= \begin{vmatrix} 0 & 0.2 & 0.1 & 0.5 & 0.1 & 0.1 \\ 0 & 0.2 & 0.4 & 0.2 & 0.2 & 0 \\ 0 & 0.4 & 0.2 & 0.2 & 0.2 & 0 \end{vmatrix} & Y_{B2} &= \begin{vmatrix} 0.2 & 0.2 & 0.4 & 0.2 & 0 & 0 \\ 0 & 0.2 & 0.4 & 0.2 & 0.1 & 0 \\ 0 & 0.1 & 0.1 & 0.3 & 0.3 & 0.2 \end{vmatrix} \\
 Y_{B3} &= \begin{vmatrix} 0.2 & 0.2 & 0.4 & 0.2 & 0 & 0 \\ 0 & 0.2 & 0.4 & 0.2 & 0.2 & 0 \\ 0 & 0.2 & 0.2 & 0.5 & 0.1 & 0 \end{vmatrix} & Y_{B4} &= \begin{vmatrix} 0.2 & 0.2 & 0.4 & 0.2 & 0 & 0 \\ 0 & 0.2 & 0.2 & 0.5 & 0.1 & 0 \\ 0 & 0.3 & 0.4 & 0.2 & 0.1 & 0 \end{vmatrix} \\
 Y_{B5} &= \begin{vmatrix} 0.2 & 0.2 & 0.4 & 0.2 & 0 & 0 \\ 0 & 0.2 & 0.2 & 0.5 & 0.1 & 0 \\ 0 & 0.3 & 0.4 & 0.2 & 0.1 & 0 \end{vmatrix} & Y_{B6} &= \begin{vmatrix} 0 & 0.3 & 0.4 & 0.2 & 0.1 & 0 \\ 0 & 0.2 & 0.1 & 0.5 & 0.1 & 0.1 \\ 0.2 & 0.2 & 0.4 & 0.2 & 0 & 0 \end{vmatrix}
 \end{aligned}$$

**Data analysis**

The above secondary indicators are analyzed, and the evaluation vector of each indicator is calculated as follows:

$$R_{B1}=Y_{B1} \times V = \begin{bmatrix} 0 & 0.2 & 0.1 & 0.5 & 0.1 & 0.1 \\ 0 & 0.2 & 0.4 & 0.2 & 0.2 & 0 \\ 0 & 0.4 & 0.2 & 0.2 & 0.2 & 0 \end{bmatrix} \times \begin{bmatrix} 1 \\ 2 \\ 3 \\ 4 \\ 5 \\ 6 \end{bmatrix} = \begin{bmatrix} 3.8 \\ 3.4 \\ 2.4 \end{bmatrix}$$

$$R_{B4}=Y_{B4} \times V = \begin{bmatrix} 0.2 & 0.2 & 0.4 & 0.2 & 0 & 0 \\ 0 & 0.2 & 0.2 & 0.5 & 0.1 & 0 \\ 0 & 0.3 & 0.4 & 0.2 & 0.1 & 0 \end{bmatrix} \times \begin{bmatrix} 1 \\ 2 \\ 3 \\ 4 \\ 5 \\ 6 \end{bmatrix} = \begin{bmatrix} 3 \\ 3 \\ 4.6 \end{bmatrix}$$

$$R_{B2}=Y_{B2} \times V = \begin{bmatrix} 0.2 & 0.2 & 0.4 & 0.2 & 0 & 0 \\ 0 & 0.2 & 0.4 & 0.2 & 0.1 & 0 \\ 0 & 0.1 & 0.1 & 0.3 & 0.3 & 0.2 \end{bmatrix} \times \begin{bmatrix} 1 \\ 2 \\ 3 \\ 4 \\ 5 \\ 6 \end{bmatrix} = \begin{bmatrix} 2.6 \\ 3 \\ 4.4 \end{bmatrix}$$

$$R_{B5}=Y_{B5} \times V = \begin{bmatrix} 0.2 & 0.2 & 0.4 & 0.2 & 0 & 0 \\ 0 & 0.2 & 0.2 & 0.5 & 0.1 & 0 \\ 0 & 0.3 & 0.4 & 0.2 & 0.1 & 0 \end{bmatrix} \times \begin{bmatrix} 1 \\ 2 \\ 3 \\ 4 \\ 5 \\ 6 \end{bmatrix} = \begin{bmatrix} 2.6 \\ 3.6 \\ 3.1 \end{bmatrix}$$

$$R_{B3}=Y_{B3} \times V = \begin{bmatrix} 0.2 & 0.2 & 0.4 & 0.2 & 0 & 0 \\ 0 & 0.2 & 0.4 & 0.2 & 0.2 & 0 \\ 0 & 0.2 & 0.2 & 0.5 & 0.1 & 0 \end{bmatrix} \times \begin{bmatrix} 1 \\ 2 \\ 3 \\ 4 \\ 5 \\ 6 \end{bmatrix} = \begin{bmatrix} 2.6 \\ 3.4 \\ 3.6 \end{bmatrix}$$

$$R_{B6}=Y_{B6} \times V = \begin{bmatrix} 0 & 0.3 & 0.4 & 0.2 & 0.1 & 0 \\ 0 & 0.2 & 0.1 & 0.5 & 0.1 & 0.1 \\ 0.2 & 0.2 & 0.4 & 0.2 & 0 & 0 \end{bmatrix} \times \begin{bmatrix} 1 \\ 2 \\ 3 \\ 4 \\ 5 \\ 6 \end{bmatrix} = \begin{bmatrix} 3.1 \\ 3.8 \\ 2.6 \end{bmatrix}$$

According to the weights of each indicator in the above table, the evaluation value of each indicator can be obtained, and the results are as follows:

$$P_{B4}=W_{B4} \times R_{B4} = |0.1365 \quad 0.2385 \quad 0.625| \times \begin{bmatrix} 3 \\ 3 \\ 4.6 \end{bmatrix} = |4|$$

$$P_{B1}=W_{B1} \times R_{B1} = |0.5816 \quad 0.309 \quad 0.1095| \times \begin{bmatrix} 3.8 \\ 3.4 \\ 2.4 \end{bmatrix} = |3.5235|$$

$$P_{B5}=W_{B5} \times R_{B5} = |0.122 \quad 0.5584 \quad 0.3196| \times \begin{bmatrix} 2.6 \\ 3.6 \\ 3.1 \end{bmatrix} = |3.3182|$$

$$P_{B2}=W_{B2} \times R_{B2} = |0.1365 \quad 0.2385 \quad 0.625| \times \begin{bmatrix} 2.6 \\ 3 \\ 4.4 \end{bmatrix} = |3.3841|$$

$$P_{B6}=W_{B6} \times R_{B6} = |0.3196 \quad 0.5584 \quad 0.122| \times \begin{bmatrix} 3.1 \\ 3.8 \\ 2.6 \end{bmatrix} = |3.4299|$$

$$P_{B3}=W_{B3} \times R_{B3} = |0.122 \quad 0.3196 \quad 0.5584| \times \begin{bmatrix} 2.6 \\ 3.4 \\ 3.6 \end{bmatrix} = |3.4141|$$

It reveals that the risk assessment of the fresh food cold chain is as follows:  $P_{B1}$  planning process risk =3.5235;  $P_{B2}$  information technology risk =3.8341;  $P_{B3}$  production process risk =3.4141;  $P_{B4}$  procurement and supply risk =4;  $P_{B5}$  distribution process risk =3.3182;  $P_{B6}$  return process risk =3.4299. The weight of the secondary indicators concerning the total target is obtained as follows:

$$W = (0.1293 \quad 0.3223 \quad 0.0941 \quad 0.0524 \quad 0.3013 \quad 0.1006)$$

$$PB = (3.52354 \quad 3.4141 \quad 3.3182 \quad 3.4299 \quad 3.3841) T$$

Therefore, the overall score of the fresh food cold chain risk index can be calculated as:  $HA = W \times PB = 3.5806$

## Findings

From the above data, we can see that the overall risk score of the fresh food supermarket cold chain is 3.5806, which means that the risk level is high. Among them, the risk of procurement and supply is 4, which is a high-risk level, especially since the quality of products is 4.6. In the second place, the Information Technology risk scores 3.3841, which is a high level of risk, with 4.4 points for information distortion. The planning process risk scored 3.5235, a high-risk level, with a high risk of improper market demand. The return process risk, production process risk, and distribution process risk scores are 3.4299, 3.4141, and 3.3182 respectively, which also belong to the low-risk status.

## COUNTERMEASURES AND SUGGESTIONS

### Planning Process Risk Prevention

The planning process risk, which serves as a precursor to the overall supply chain risk, requires careful attention from supermarket enterprises. By improving market demand forecasting analysis and establishing real-time network systems, supermarkets can regulate procurement demand and stabilize prices to achieve a balanced state aligned with strategic objectives.

### Information Technology Risk Prevention

To prevent information technology risks, it is necessary to establish a professional and diversified information service platform. This platform can address information asymmetry promptly and ensure effective information sharing across all supply chain links. Technologies such as barcodes, radio frequency identification, global positioning systems, and mobile logistics information technology should be promoted to establish a regional platform for real-time monitoring of product quality and safety.

### Production Process Risk Prevention



In terms of production process risk prevention, there is a need to enhance the legal and regulatory system of cold chain logistics. This includes improving national unified standards and developing guidelines and standards that align with international best practices. Additionally, improving farming and breeding technologies is essential for ensuring the survival and harvest rates of crops, while aligning crop selection with consumer preferences plays a vital role in meeting market demands.

### Procurement and Supply Risk Prevention

Procurement and supply risk prevention require close collaboration between marketing and purchasing departments. By selecting and examining supplier partners carefully and establishing long-term and stable relationships, supermarkets can ensure the quality and safety of agricultural products. Government standards that guarantee product quality and safety should also be advocated for.

### Distribution Process Risk Prevention

Addressing the distribution process risk involves improving the cold chain logistics infrastructure and developing a well-connected transportation network. Supporting and promoting the "agricultural base-supermarket" model is crucial in further enhancing the supply chain. Investments in new refrigerated vehicles and advanced technologies such as automated cold storage, vacuum cooling, and temperature and humidity control should be made to optimize the distribution process. Collaboration through joint ventures, mergers, and acquisitions can facilitate the integration of existing resources and establish large-scale cryogenic logistics centers.

### Return Process Risk Prevention

To prevent risks in the return process, continuous improvement of basic cold chain equipment and facilities is necessary. Repairing or replacing problematic refrigerated trucks and cold storage equipment ensures the smooth operation of infrastructure. Information technology should be further enhanced to enable real-time monitoring of product quality and timely handling of products with quality issues. Optimizing routes and vehicle assignments in real-time, along with systematic training for staff, enhances overall business capabilities and service consciousness.

## CONCLUSION

The advancement of the big data era and the rapid development of new circulation modes, such as e-commerce, the agricultural base-supermarket model, and daily selection, have contributed to the increasing complexity of the fresh food cold chain. This study identifies potential risk factors in the fresh food cold chain and constructs a risk index system using an improved SCOR model. Based on this model, six primary risk indicators and eighteen secondary risk indicators are carefully selected and modeled using AHP-FCE analysis. Subsequently, mathematical operations are performed to determine the importance and ranking of risk factors at each level. Finally, we propose corresponding countermeasures and suggestions based on each risk indicator. However, it is important to note that expert scoring introduces subjective factors, which may impact the objectivity of the resulting indicators. Additionally, there are certain limitations in the selection of risk factor indicators. Thus, future research should primarily focus on addressing these issues.

## REFERENCES

- Al-Aomar, R., & Hussain, M. (2019). Exploration and prioritization of lean techniques in a hotel supply chain. *International Journal of Lean Six Sigma*, 10(1), 375–396. <https://doi.org/10.1108/ijlss-10-2017-0119>
- Bahurmoz, A. (2006). The Analytic Hierarchy Process: A Methodology for Win-Win Management. *Journal of King Abdulaziz University-Economics and Administration*, 20(1), 3–16. <https://doi.org/10.4197/eco.20-1.1>
- Chen, X. (2007). Feng, J. Agriculture Products Supply Chain Risk Management. *Productivity Research*, (05), 28-29+105. doi:10.19374/j.cnki.14-1145/f.2007.05.013. (in Chinese)
- Gu, Z. (2011). A Fuzzy Comprehensive Evaluation and Study of the Endogenetic Risks of Supply Chain Management. *Modern Management*, 01(03), 176–181. <https://doi.org/10.4236/mm.2011.13032>
- Karimi, B., Niknamfar, A. H., Hassan Gavyar, B., Barzegar, M., & Mohtashami, A. (2019). Multi-objective multi-facility green manufacturing closed-loop supply chain under uncertain environment. *Assembly Automation*, 39(1), 58–76. <https://doi.org/10.1108/aa-09-2018-0138>
- Liu, M., Ni, J.B., Wang Y., Yang Y.H., Ge, B. (2018). Research on Risk Management of E-commerce Fresh Produce Cold Chain Logistics. *Market Modernization*, 2018(17): 49-50. DOI:10.14013/j.cnki.sixth.2018.17.026. (in Chinese)
- Narayanan, A. E., Sridharan, R., & Ram Kumar, P. N. (2019). Analyzing the Interactions among Barriers of Sustainable Supply Chain Management Practices. *Journal of Manufacturing Technology Management*, 30(6), 937–971. <https://doi.org/10.1108/jmtm-06-2017-0114>
- Pan, Y.M., Chen J. (2020). Risk Analysis and Countermeasure Research of Cold Chain Logistics. *Logistics Engineering and Management*, 42(01): 47-48+46. (in Chinese)
- Saaty, T. L. (1986). A note on the AHP and expected value theory. *Socio-Economic Planning Sciences*, 20(6), 397–398. [https://doi.org/10.1016/0038-0121\(86\)90053-4](https://doi.org/10.1016/0038-0121(86)90053-4)
- Shao, X., Gao, K., & Kang, T. (2019). Research on the Supply Chain Risk Evaluation Index of Chinese Fresh Agricultural Products Based on Analytic Hierarchy Process. *Korean-Chinese Social Science Studies*, 17(1), 7–24. <https://doi.org/10.36527/kcsss.17.1.1>

- Xiang, Z.Z. (2019). Research on Quality and Safety Risk of Food Supply Chain Based on Scenario Analysis. *Sustainable Development*, 09(03), 392–401. <https://doi.org/10.12677/sd.2019.93048>
- Zadeh, L. A. (1985). Fuzzy sets. *Information and Control*, 8(3), 338–353. [https://doi.org/10.1016/s0019-9958\(65\)90241-x](https://doi.org/10.1016/s0019-9958(65)90241-x)
- Zhang, L. (2018). Research on Risk Management of Fresh Produce Supply Chain. [D] *Shijiazhuang Railway University*. (in Chinese)
- Zhang, S., He Y.R. (2019). Risk Assessment of Cold Chain Logistics-based on AHP. *Journal of Tianjin College of Commerce*, 7(06): 47-52. DOI:10.16130/j.cnki.12-1434/f.2019.06.008. (in Chinese)
- Zhou, H., Benton, W. C., Schilling, D. A., & Milligan, G. W. (2011). Supply Chain Integration and the SCOR Model. *Journal of Business Logistics*, 32(4), 332–344. <https://doi.org/10.1111/j.0000-0000.2011.01029.x>

## Comprehensive Risk Management Matrix in Agile EDA Project Management for Semiconductor Industry- A Case Study

Terence S.-Y. Chen <sup>1,\*</sup>

\*Corresponding author

<sup>1</sup> University HEC Liège Executive Education, Management School- Liège Université, Belgium, Executive Doctorate in Business Administration (EDBA), Student, terence2045@gmail.com

### ABSTRACT

This paper aims to present a comprehensive risk management matrix as a crucial element in agile project management practices for electronic design automation (EDA) software in the semiconductor industry. Specifically, this study focuses on the development and implementation of the matrix to manage risks in the context of an Optical Phase Array (OPA) design project for LiDAR in medical services. The case study illustrates how a meticulously crafted risk management matrix can support risk management within agile approaches and lead to more efficient and effective project outcomes. The matrix is incorporated into various risk management techniques, including risk identification, assessment, mitigation, and monitoring, to enhance the management of project risks. The research findings contribute to the growing body of literature on the application of comprehensive risk management strategies in agile project management and provide valuable insights for practitioners seeking to leverage these techniques for improved risk management in EDA software projects in the semiconductor industry.

*Keywords:* Agile project management, EDA, risk management, LiDAR, semiconductor.

### INTRODUCTION

In recent years, the application of comprehensive risk management strategies has gained significant interest, particularly in the context of agile project management, as discussed by Nieto-Rodriguez, A., & Vargas, R. V. (2023). Agile project management is a methodology that prioritizes flexibility and adaptability in project planning and execution while focusing on delivering value to customers through iterative development cycles. In this paper, we investigate the role of a comprehensive risk management matrix in enhancing risk management strategies in agile project management. Specifically, we explore how this matrix can be effectively incorporated into electronic design automation (EDA) software projects for LiDAR in medical services, a domain where risk management is critical for project success, as emphasized by Ramadhan, S. F., Taufik, M., Novita, D., & Turnip, A. (2021).

The case study presented in this research demonstrates how a well-designed risk management matrix can support risk management within agile project management practices, leading to improved efficiency and effectiveness. By integrating the matrix into various risk management techniques, including risk identification, assessment, mitigation, and monitoring, teams can better communicate and collaborate with stakeholders to manage project risks effectively. Our research contributes to the growing body of literature on the application of comprehensive risk management strategies in agile project management and offers valuable insights for practitioners seeking to integrate these techniques for more robust risk management in their projects.

To develop and evaluate new artifacts that integrate a comprehensive risk management matrix into agile project management processes for risk management, we employ a design science research methodology. Through this research, we aim to provide a useful resource for practitioners looking to enhance their risk management practices in the context of EDA software projects in the semiconductor industry.

### LITERATURE REVIEW

The integration of comprehensive risk management strategies in agile project management, a topic of increasing interest in recent years for its potential to enhance risk management strategies, has been thoroughly studied by Belharet, A., Bharathan, U., Dzingina, B., Madhavan, N., Mathur, C., & Toti, Y.-D. B. (2020). The exploration of how structured risk management strategies could improve various project management tasks, including risk identification, assessment, mitigation, and monitoring, was comprehensively addressed by Nieto-Rodriguez, A., & Vargas, R. V. (2023). Dam, H. K., et al. (2019) identified several challenges in agile project management that could be addressed using comprehensive risk management strategies, such as risk identification and prioritization, as well as risk mitigation planning.

The literature suggests that comprehensive risk management strategies can revolutionize risk management in agile project management by facilitating faster and better risk assessment and mitigation through structured processes, reducing biases and errors through the analysis of detailed risk factors, providing insights for informed decision-making, enabling seamless collaboration and communication among team members, and minimizing the risks of delays and mistakes that may impact project outcomes and timelines.

In the context of our research, Optical Phase Array (OPA) technology is a beam-pointing technology characterized by its high-speed, flexibility, and non-mechanical nature. This technology, which Wang, R., Yan, D., Wang, J., Wang, G., & Zhao, Q. (2020) discussed, has found widespread applications in various fields, such as target detection, imaging recognition, tracking scanning, laser interference, and medical services, among others. Fukui, T., Tanomura, R., Komatsu, K., Yamashita, D., Takahashi, S., Nakano, Y., & Tanemura, T. (2021) identified the Optical Phased Array (OPA) as a promising beam-steering device for a range of applications, including Light Detection and Ranging (LiDAR), optical projection, free-space optical communication, and switching for medical services.

The integration of comprehensive risk management strategies in the development of OPA systems for LiDAR medical services presents an opportunity to enhance risk management practices in agile project management.

## RESEARCH METHOD

In this study, we will be using the design science research methodology to develop and evaluate new artifacts that integrate a comprehensive risk management matrix into risk management processes within agile project management. Design science research, a research methodology that emphasizes the creation and evaluation of artifacts to address practical issues, involves stages such as problem identification and motivation, defining the solution's objectives, design and development, demonstration, evaluation, and communication (Peppers, Rothenberger, & Tuunanen, 2007). The sequence of the feedback process is designed in the middle of the research framework shown in figure 1. The goal of design science research is to create innovative and effective solutions to real-world problems through the application of rigorous scientific methods.

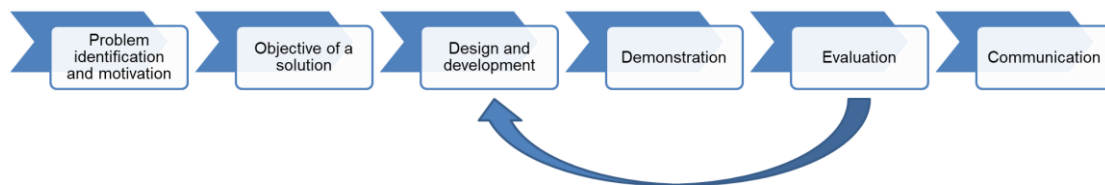

*Source:* This study.

Figure 1: The design science research (DSR) approach

Our design science research process will involve several key steps. First, we will identify and motivate the problem of integrating a comprehensive risk management matrix into risk management practices within agile project management. This will involve a review of the literature on risk management matrices, risk management, and agile project management, as well as an analysis of the challenges and opportunities associated with their integration.

Next, we will define the objectives for our solution, which will involve specifying the desired features and capabilities of our artifacts. We will then design and develop our artifacts, which may include new models, methods, or tools for integrating a comprehensive risk management matrix into risk management processes in agile project management.

Once our artifacts have been developed, we will demonstrate their utility through a case study involving the development of an electronic design automation (EDA) software to design an Optical Phase Array (OPA) used in LiDAR for medical service. This case study will provide an opportunity to evaluate the effectiveness of our artifacts in improving risk management efficiency and effectiveness within agile project management.

## RESEARCH STEPS

### Problem Definition and Motivation

Our problem definition and motivation center on understanding the potential of a comprehensive risk management matrix in enhancing risk management strategies within agile project management, and examining its tangible effects on risk assessment, mitigation, and monitoring within the context of a case study focusing on the development of EDA software for designing LiDAR systems for medical services.

### Objective of a Solution

The objective of our solution is to develop new artifacts, such as a framework, methods, or tools, that can effectively integrate a comprehensive risk management matrix into risk management processes within agile project management. These artifacts should help teams to better identify, assess, mitigate, and monitor project risks, improve communication and collaboration among team members and stakeholders related to risk management, and streamline risk management processes within agile project management.

### Design and Development

We present a case study that explores the design and development of PhotoCAD, an Electronic Design Automation (EDA) software that employs design science research methodology to seamlessly incorporate a comprehensive risk management matrix

into agile project management processes. This study offers insights into the utilization of various frameworks and strategies, including Objectives and Key Results (OKRs), user stories, and risk exposure matrices, all aimed at optimizing PhotoCAD's performance, user satisfaction, and market competitiveness.

### The Portfolio of Project Management Artifacts

We use design science research methodology to develop new artifacts that integrate AIGC into agile project management processes and perform the EDA software development for the case study. PhotoCAD is the name of this EDA software:

1. Objectives and Key Results (OKR) is a goal-setting framework utilized to establish and monitor objectives along with their respective outcomes (Stray, Moe, Vedal, & Berntzen, 2021). To create an OKR table for PhotoCAD software, we need to first define the objectives for using the software. Once the objectives are defined, we can then identify the key results that will help us measure progress towards achieving those objectives. Here is an example of an OKR table for PhotoCAD software in table 1:

Table 1: OKR table for PhotoCAD software project

Objectives	Key Results
Increase productivity by using PhotoCAD for photonics chip layout design	1.Reduce design time by 30% compared to previous methods
	2.Increase the number of completed designs by 50% within the next quarter
	3.Achieve a 90% satisfaction rate among team members using PhotoCAD
Improve design accuracy and quality with PhotoCAD	1.Reduce design errors by 40% compared to previous methods
	2.Achieve a 95% success rate in design rule checks
	3.Receive positive feedback from clients on design quality
Enhance team collaboration and knowledge sharing with PhotoCAD	1. Conduct at least one training session on using PhotoCAD per month
	2. Establish a shared repository for design templates and best practices
	3. Increase the number of collaborative projects using PhotoCAD by 30% within the next quarter
Expand the use of PhotoCAD to new projects and clients	1. Identify at least two new projects or clients that can benefit from using PhotoCAD
	2.Conduct a successful pilot project using PhotoCAD with a new client
	3.Increase revenue from projects using PhotoCAD by 20% within the next quarter

Source: This study.

2. User stories are short, simple descriptions of a feature or function that a user needs from the software. They are written from the perspective of the user and typically follow the format "As a [user], I want [functionality], so that [benefit]." Here are some example user stories for a PhotoCAD software project using agile project management:
  - As a component designer, I want to be able to create parametric device layout units using Python scripts quickly and easily in PhotoCAD, so that I can improve my productivity and design accuracy.
  - As an engineer, I want to be able to access a library of pre-built components and design templates in PhotoCAD, so that I can save time and reduce errors in my designs.
  - As a project manager, I want to be able to track the progress of my team's designs in real-time using PhotoCAD, so that I can ensure that we are meeting our project milestones and delivering high-quality designs to our clients.
  - As a client, I want to be able to review and provide feedback on designs created using PhotoCAD, so that I can ensure that the final product meets my needs and expectations.

These user stories provide a clear and concise description of the features and functionality that users need from the PhotoCAD software. They can be used to prioritize development efforts and ensure that the software meets the needs of its users.

Table 2: Risk exposure matrix

Scenario	Risk to project (H/M/L)	Mitigation Plan
Inadequate testing	High	Develop a comprehensive test plan and execute it thoroughly
Incomplete requirements	Medium	Ensure that requirements are well-defined and documented
Scope creep	High	Establish a change control process and adhere to it

Source: This study.

### Demonstration

We launched PhotoCAD, a flexible scripting framework that focuses on component-level and circuit-level photonic design. This framework is completely script-driven, utilizing the latest industry-standard Python3 language, increasing flexibility and reducing duplication of effort. The PhotoCAD result is demonstrated in figure 2. Note that OPA used in LiDAR for medical service is included in figure 2.

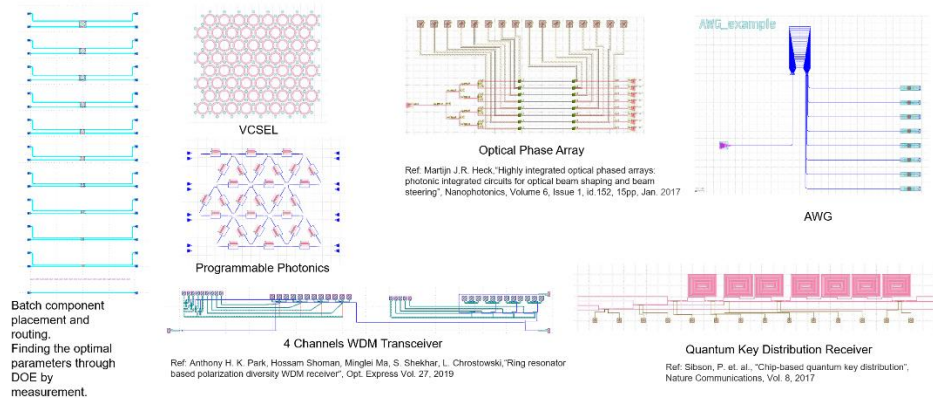

Source: This study.

Figure 2: PhotoCAD demonstration

### Evaluation

A burndown chart is a graphical representation of the remaining work in an Agile project over time. It helps to track the progress of the project and shows how much work is left to complete before the end of the project. We compared the actual trendline with the ideal trendline. The actual trendline is above the ideal trendline, it indicates that the project is behind schedule, and the team needs to work harder to catch up as shown in figure 3.

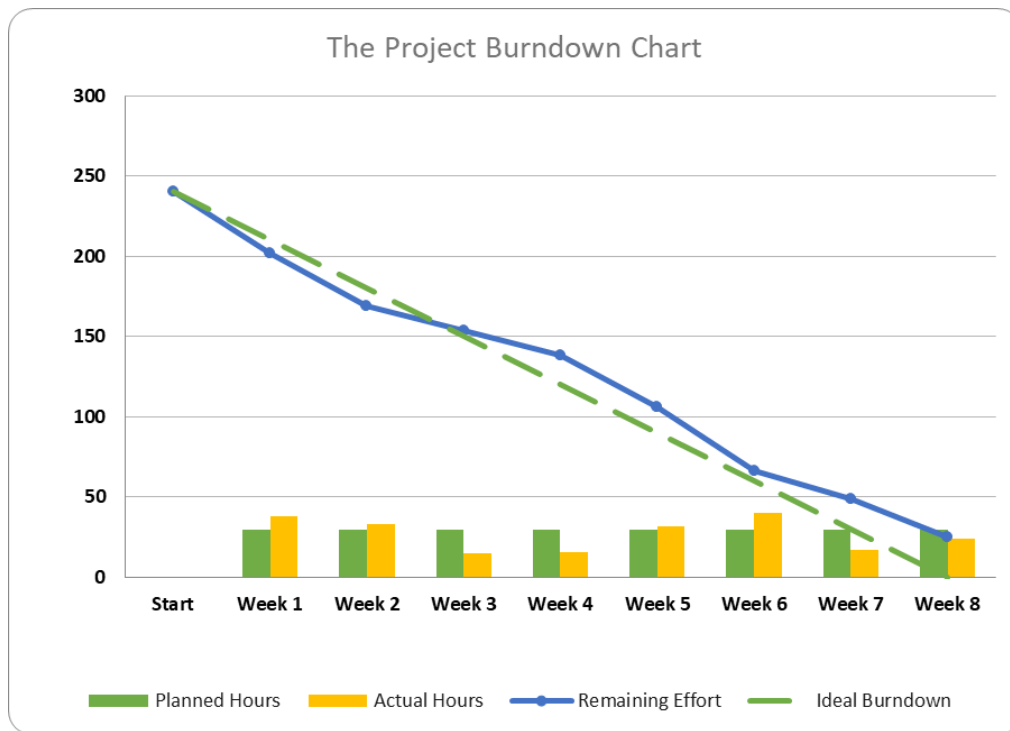

Source: This study.

Figure 3: The burndown chart with the 1st iteration

A burndown chart is a graphical representation of the remaining work in an Agile project over time. It helps to track the progress of the project and shows how much work is left to complete before the end of the project. We compared the actual trendline with the ideal trendline. The actual trendline is above the ideal trendline, it indicates that the project is behind schedule, and the team needs to work harder to catch up as shown in Figure 3.

### The second design and development

The integration of a comprehensive risk management matrix within agile project management has the potential to enhance risk management practices by creating more comprehensive risk scenarios. By leveraging the capabilities of this comprehensive matrix, teams can more effectively identify, assess, mitigate, and monitor project risks, leading to improved efficiency and effectiveness in managing project risks. This approach can help teams better anticipate and manage potential risks, leading to improved project delivery and outcomes. We compile the data from the first iteration of this project and generate the comprehensive risk control techniques that can be used in software development in Table 3, including:

1. Risk avoidance: This involves changing the project plan or scope to eliminate or avoid the risk altogether.
2. Risk transfer: This involves transferring the risk to a third party, such as through insurance or outsourcing.
3. Risk reduction: This involves taking steps to reduce the likelihood or impact of the risk, such as through additional testing, quality control measures, or contingency planning.
4. Risk acceptance: This involves accepting the risk and its potential consequences, and planning for how to deal with them if they occur.

Table 3: Risk control technique matrix

Risk	Avoidance	Transfer	Reduction	Acceptance
PhotoCAD Requirements risk	Adjust project scope to eliminate unclear requirements.	N/A	Clear and detailed requirements documentation; Regular communication with stakeholders to manage changes.	Accept the risk and plan for potential changes in requirements.
PhotoCAD Technical risk	Avoid using untested or unreliable technologies.	N/A	Research and testing of new technologies; Regular technical reviews; Prototyping and proof-of-concept development.	Accept the risk and plan for potential technical challenges.
PhotoCAD Schedule risk	Extend project timeline to reduce	N/A	Detailed project schedule with built-in contingencies; Regular schedule reviews	Accept the risk and plan for potential schedule delays.



	schedule pressure.		and updates; Resource leveling and allocation.	
PhotoCAD Resource risk	Reduce project scope to match available resources.	Outsource some project tasks to third-party vendors.	Detailed resource plan with built-in contingencies; Regular resource reviews and updates; Resource leveling and allocation.	Accept the risk and plan for potential resource constraints.

Source: This study.

We create another risk management matrix that includes control techniques of avoidance, transfer, reduction, and acceptance, and there are several other techniques that can be used to manage risks in software development, including:

1. Regular risk assessments: Conducting regular risk assessments throughout the project lifecycle can help identify new risks and monitor the effectiveness of risk control measures.
2. Stakeholder engagement: Engaging with stakeholders, including customers, team members, and suppliers, can help identify potential risks and develop effective risk control measures.
3. Continuous monitoring: Monitoring project progress, key performance indicators, and other metrics can help identify potential risks and trigger early warning signs.
4. Contingency planning: Developing contingency plans for high-impact risks can help reduce their potential impact and improve the project's resilience.

It's important to note that effective risk management requires a combination of techniques and ongoing effort throughout the project lifecycle in Table 4.

Table 4: Risk management effort throughout the project lifecycle

Risk	Regular Risk Assessments	Stakeholder Engagement	Continuous Monitoring	Contingency Planning
PhotoCAD Requirements risk	Periodic risk assessments to identify and analyze potential risks associated with project requirements.	Engage stakeholders in risk identification and management, considering their perspectives throughout the process.	Continuously monitor project requirements, assess their impact, and identify potential risks.	Develop proactive contingency plans for high-impact requirements risks.
PhotoCAD Technical risk	Regular evaluations to identify potential technical risks and vulnerabilities in project aspects and components.	Engage stakeholders with technical expertise to assess and manage technical risks through collaboration and knowledge sharing.	Continuously monitor technical performance, system integrations, and emerging technologies for potential risks.	Develop comprehensive contingency plans to minimize the impact of high-impact technical risks.
PhotoCAD Schedule risk	Regular risk assessments to identify potential schedule risks, considering dependencies, resource availability, and bottlenecks.	Collaboratively analyze and manage schedule risks with stakeholders, ensuring transparent communication and realistic timelines.	Continuously monitor project progress, milestones, and indicators for schedule deviations and potential risks.	Develop robust contingency plans to minimize the impact of high-impact schedule risks.
PhotoCAD Resource risk	Regular assessments of resource requirements and availability, considering skills, capacity, turnover, and external dependencies.	Engage stakeholders involved in resource allocation for effective resource planning and management.	Continuously monitor resource utilization, availability, and performance for potential risks.	Develop comprehensive contingency plans to mitigate high-impact resource risks.
PhotoCAD Quality risk	Regular quality assessments and audits to identify potential quality risks and deviations from standards.	Engage stakeholders in quality risk management through collaboration and continuous improvement initiatives.	Continuously monitor quality metrics, customer feedback, and quality control processes for potential risks.	Develop robust contingency plans to ensure timely resolution of high-impact quality risks.

Source: This study.

We design one more management matrix that can be utilized to manage risks in software development in Table 5, including:

1. Risk prioritization: Prioritizing risks based on their likelihood and potential impact can help focus risk management efforts on the most critical risks.
2. Risk communication: Communicating risks and risk management plans to stakeholders can help ensure that everyone is aware of the risks and their potential impact and can help build support for risk management efforts.
3. Risk escalation: Escalating high-impact risks to higher levels of management can help ensure that they receive the attention and resources they need to be effectively managed.
4. Lessons learned: Capturing and sharing lessons learned from past projects can help improve risk management practices and prevent similar risks from occurring in future projects.

Table 5: Risk management communication matrix

Risk	Risk Prioritization	Risk Communication	Risk Escalation	Lessons Learned
PhotoCAD Requirements risk	Assess and rank risks based on their likelihood, impact, and alignment with project objectives.	Engage stakeholders in open discussions to exchange information about requirements risks.	Escalate significant requirements risks to higher management levels for further evaluation and decision-making.	Capture valuable insights from past projects to refine requirements risk management strategies.
PhotoCAD Technical risk	Evaluate and prioritize technical risks based on their potential impact on project success and technical feasibility.	Facilitate clear and concise communication channels to share technical risks with stakeholders.	Escalate critical technical risks to higher management for prompt attention and action.	Document key learnings from previous projects to enhance technical risk management approaches.
PhotoCAD Schedule risk	Analyze and prioritize schedule risks considering their potential to affect project timelines and critical milestones.	Foster transparent and proactive communication with stakeholders regarding schedule risks and mitigation strategies.	Escalate high-impact schedule risks to higher management levels, providing detailed analysis and recommended actions.	Extract valuable lessons learned from past projects to refine schedule risk management practices.
PhotoCAD Resource risk	Prioritize resource risks based on their potential to impact project deliverables, considering factors such as skill availability and resource constraints.	Establish effective channels for sharing resource risks and mitigation plans with stakeholders.	Escalate significant resource risks to higher management levels, providing comprehensive assessments and recommendations.	Collect and analyze lessons learned from previous projects to optimize resource risk management strategies.
PhotoCAD Quality risk	Assess and prioritize quality risks based on their potential to impact project outcomes, compliance, and customer satisfaction.	Implement clear and concise communication strategies to convey quality risks to stakeholders.	Escalate high-impact quality risks to higher management levels, providing in-depth analysis and proposed actions.	Document valuable insights gained from previous projects to enhance quality risk management practices.

Source: This study.

### Further Evaluation

After implementing an extensive risk management matrix and improving the scope of risk estimation, in our subsequent project cycle, the actual hours closely align with the planned hours, as evidenced by the burndown chart as shown in figure 4.

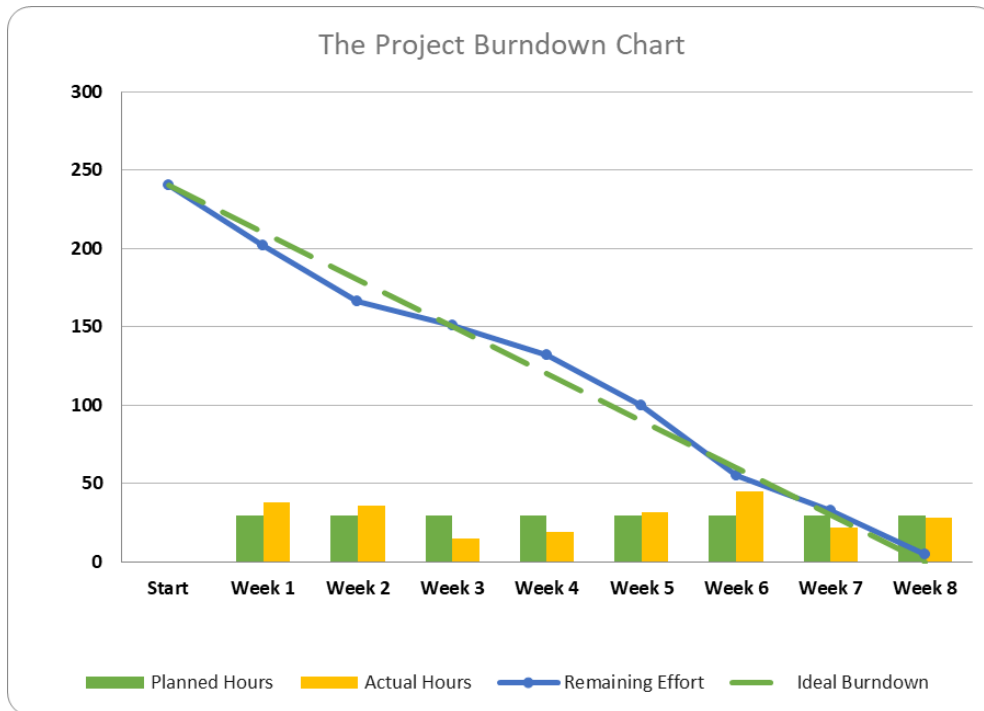

Source: This study.

Figure 4: The burndown chart with the 2nd iteration

### Lessons Learned

Throughout the process of incorporating a comprehensive risk management matrix within the context of agile project management in the development of PhotoCAD, we gathered several key insights:

1. **Continuous Risk Management:** We found that effective risk management is not a one-time activity, but a continuous process that runs parallel to the entire lifecycle of the PhotoCAD project. Regular risk assessments and updates to risk mitigation strategies were required based on changes in the project's scope and environment.
2. **Criticality of Risk Communication:** We realized the importance of transparent risk communication. Clearly communicating risks, their potential impacts, and mitigation strategies to all stakeholders, including the PhotoCAD development team, ensured everyone was on the same page and could effectively contribute to risk mitigation.
3. **Necessity for Risk Prioritization:** Prioritizing risks based on their potential impact and likelihood was a vital strategy. This approach focused the team's efforts on the most substantial risks, improving efficiency, and ensuring that high-impact risks associated with PhotoCAD were adequately addressed.
4. **The Power of Past Lessons:** Documenting and reviewing lessons learned from past stages of the PhotoCAD project proved to be invaluable. It helped improve future risk management practices and prevented the recurrence of similar risks.
5. **Importance of Risk Escalation:** We learned that high-impact risks should be escalated to higher management levels. This practice ensured these risks received the attention and resources necessary for effective management within the PhotoCAD project.
6. **Alignment of Planned and Actual Hours:** With the implementation of the comprehensive risk management matrix, there was a significant improvement in aligning planned and actual hours dedicated to the PhotoCAD project. This demonstrated the matrix's effectiveness in mitigating risks related to project timelines.

These lessons will significantly improve the agility and effectiveness of risk management within an EDA software project like PhotoCAD moving forward.

### CONCLUSION

After conducting this research on the development and implementation of a comprehensive risk management matrix in agile project management for EDA software in the semiconductor industry, it can be concluded that a well-crafted risk management matrix can significantly enhance the management of project risks. The findings of this study contribute to the growing body of literature on the application of comprehensive risk management strategies in agile project management and provide valuable insights for practitioners seeking to leverage these techniques for improved risk management in EDA software projects in the

semiconductor industry. Furthermore, the principles and techniques outlined in this case study can be applied to other industries and project types, making it a valuable resource for researchers and practitioners alike.

#### REFERENCES

- Belharet, A., Bharathan, U., Dzingina, B., Madhavan, N., Mathur, C., & Toti, Y.-D. B. (2020). Report on the Impact of Artificial Intelligence on Project Management. ESIEE Paris.
- Dam, H. K., et al. (2019). Towards effective AI-powered agile project management. In *Proceedings - 2019 IEEE/ACM 41st International Conference on Software Engineering: New Ideas and Emerging Results (ICSE-NIER)*.
- Fukui, T., Tanomura, R., Komatsu, K., Yamashita, D., Takahashi, S., Nakano, Y., & Tanemura, T. (2021). Non-redundant optical phased array. *School of Engineering, The University of Tokyo*.
- Nieto-Rodriguez, A., & Vargas, R. V. (2023). How AI Will Transform Project Management. *Harvard Business Review*. Retrieved from <https://hbr.org/2023/02/how-ai-will-transform-project-management>
- Peffer, K., Rothenberger, M. A., & Tuunanen, T. (2007). A Design Science Research Methodology for Information Systems Research. *Journal of Management Information Systems*, 24(3), 45-77.
- Ramadhan, S. F., Taufik, M., Novita, D., & Turnip, A. (2021). Design of 2D LiDAR-based Indoor SLAM for Medical Robot Covid-19. In *Proceedings of the 2021 International Conference on Artificial Intelligence and Mechatronics Systems (AIMS)* (pp. 1-6). IEEE.
- Stray, V., Moe, N. B., Vedal, H., & Berntzen, M. (2021). Using Objectives and Key Results (OKRs) and Slack: A Case Study of Coordination in Large-Scale Distributed Agile. *TechRxiv. Preprint*. <https://doi.org/10.36227/techrxiv.16892161.v1>
- Wang, R., Yan, D., Wang, J., Wang, G., & Zhao, Q. (2020). Research progress of LIDAR system based on optical phased array technology. In *Proceedings of SPIE 11567, AOPC 2020: Optical Sensing and Imaging Technology* (pp. 115674A). SPIE. <https://doi.org/10.1117/12.2580344>

## Data Analysis Model for Computed Tomography Usage

P.Y. Lin<sup>1,3</sup>  
H.C. Chang<sup>2,\*</sup>

\*Corresponding author

<sup>1</sup> Manager, Ditmanson Medical Foundation Chia-Yi Christian Hospital, Chiayi, Taiwan, ele83anor@gmail.com

<sup>2</sup> Information Manager, Ditmanson Medical Foundation Chia-Yi Christian Hospital, Chiayi, Taiwan, cych12452@gmail.com

<sup>3</sup> Doctoral Student, Department of Information Management, National Chung Cheng University, Chiayi, Taiwan

### ABSTRACT

Radiology medicine is one of the fields experiencing extremely rapid development in modern medicine. Among these fields, computed tomography (CT) plays a crucial role in medical clinical diagnosis. However, computed tomography have high medical costs due to expensive medical equipment, the use of contrast agents, professional radiographers operating the equipment, and the need for radiologists to interpret reports. In the current medical environment where Taiwan implements a global budget system, the rationality of the number of computed tomography examinations has always been a focus of concern. In this study, we employed Royce's waterfall model to develop a cloud-based and mobile bed dynamic model system. The primary research objective was to provide supervisors with the latest data analysis model for CT usage.

*Keywords:* computed tomography, waterfall model, cloud-based, electronic commerce, and dynamic model.

### INTRODUCTION

CT examinations can be applied to almost the entire body, and their greatest advantages are speed, versatility, and affordability. Typically, CT scans are used to detect tumors or inflammations in organs. Whether it's screening for liver cancer, lung cancer, or brain cancer, CT proves to be a powerful diagnostic tool. CT's X-ray radiation carries a carcinogenic risk, but if performed only once or twice a year, the cumulative dose remains low, and the carcinogenic risk is minimal, Jalaber *et al.* (2020). However, if the number of examinations exceeds two times a year, a careful evaluation is advisable, and hospitals must also consider the cost of CT as an important factor. In this study, we analyzed whether the volume of computed tomography scans conducted by various medical departments or different patient types in a large hospital within a specific region is excessive or high. Subsequently, we provided the hospital management with insights for formulating cost-control policies.

### LITERATURE REVIEW

#### Waterfall Model

The Waterfall Model, sometimes referred to as the classical life cycle or linear sequence model, is also known as waterfall development. The original standard for most software development adheres to the Software Development Life Cycle (SDLC) process, requiring a comprehensive experience of each stage in the life cycle, Royce *et al.* (1970). This process involves systematic considerations, including time, resources, analysis, design, and technology. The analysis, design, and implementation phases are typically subdivided into at least three stages but are often expanded to encompass five to seven stages. (2022). The requirements analysis phase focuses on gathering requirements and understanding the characteristics of the software to be created. Once the user approves the requirements phase, the Specification team creates a Specification document. The design phase transforms requirements into software representations, providing insight into code quality before production. The implementation phase involves converting designs into machine-readable code, essentially the step of code generation. Following code generation, program testing begins, and after software delivery to the user, the maintenance phase addresses inevitable changes and updates, TRahayu *et al.* (2020).

#### Computed Tomography

Computed Tomography (CT for short), also known as computerized tomography, is an imaging diagnostic examination. The technique used to be called Computed Axial Tomography (CAT). (2021). It employs computer-processed combinations of numerous X-ray measurements taken from various angles to generate cross-sectional (tomographic) images, often referred to as virtual 'slices,' of a specific scanned area of the object. This allows users to visualize the interior of the object without the need for physical dissection. In 1979, the Nobel Prize in Physiology or Medicine was jointly awarded to South African-American physicist Alan Cormack and British electrical engineer Godfrey Hounsfield for their pioneering work in the development of computer-assisted tomography, Narula *et al.* (2021).

### METHODOLOGY

The research adopts the three-stage waterfall model proposed by Winston Royce (1970). The stages of analysis, design, and implementation are shown in Figure 1. The development model requires rigorous verification in each stage. After completing one stage, proceed to the next stage. In the initial phase of the study, we used the development tool PowerBI to develop models using DAX syntax and imported the computer tomography execution volume database of outpatients, emergency and inpatients

into the Power BI system for data analysis, Becker et al. (2019). We explored different medical disciplines and physicians. The number of CT examinations issued and the occurrence of more than two body parts examined by patients on the same day are used as the data basis for feedback to the medical department. The back-end uses C# syntax to match the MS-SQL Server database, through scheduling settings, regularly updates the data, and compiles the research structure of this study through the data warehouse data, as shown in Figure 2. The usage data analysis model of computed tomography in the study, the three stages of the waterfall model in the development process are as follows. And the analysis period: from January 15, 2023, to February 15, 2023, a total of 30 days. Design phase: From February 16, 2023, to March 31, 2023, the design phase took 1.5 months to develop. Implementation stage: The function of the patient return medical system will be implemented on May 1, 2023, on the hospital's webpage and mobile presentation, to achieve the research purpose of this study.

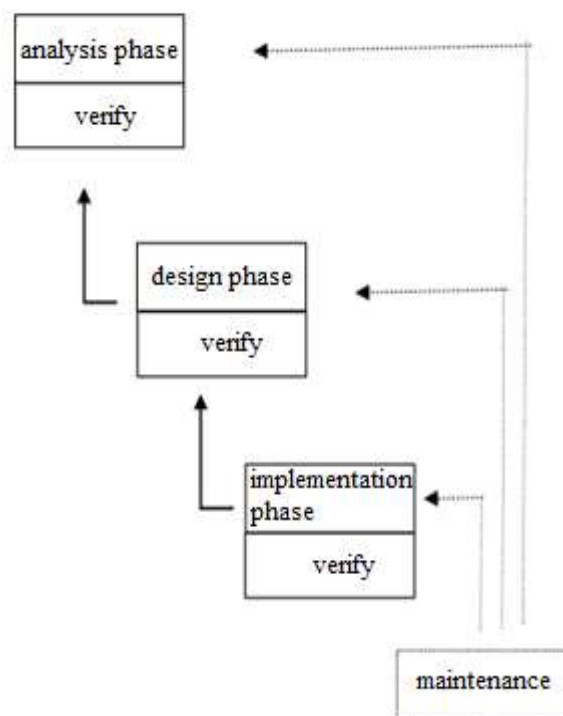

Source: Winston Royce (1970).  
Figure 1: Development model.

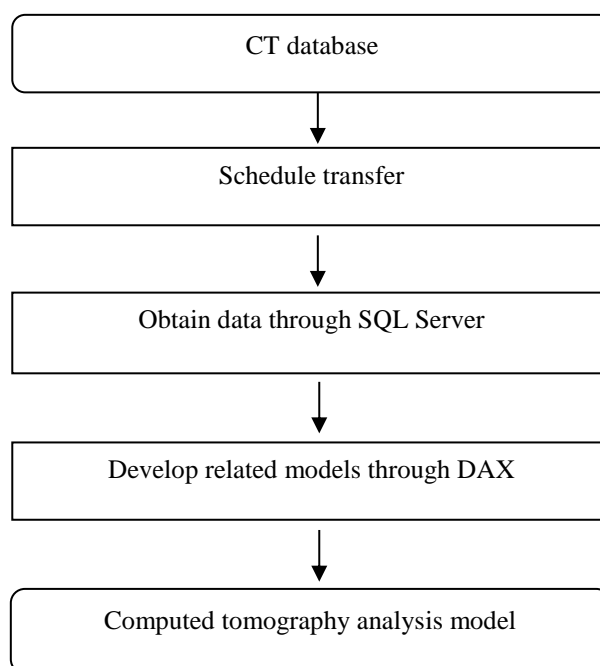

Source: This study.  
Figure 2: The reference styles in the tex.

**RESULT**

This study analyzed a total of 3,031,210 outpatients and 186,452 inpatients from January 2020 to August 2023 (Figure 2 & Figure 3). Data results indicate that in the outpatient department (Figure 4-1 & Figure 4-2), medical departments with a higher number of cancer patients, such as thoracic surgery, hematology and oncology, thoracic medicine, radiation oncology, colorectal surgery, etc., indeed exhibit a higher frequency of ordering computed tomography examinations as follow-up procedures. In the inpatient department (Figure 5-1 & Figure 5-2), departments with a significant population of critically ill patients, such as surgical intensive care, neurosurgery, neurology, cardiovascular surgery and general surgery, also demonstrate a greater proportion and repetition of computed tomography examinations for inpatients. Furthermore, when hospital management implemented specific measures, the rate of repeated scans decreased, successfully achieving the research objectives of this study. However, due to internal management requirements, we are currently unable to present the relevant data and information regarding the rate of repeated CT scans in various medical departments and the extent of their reduction. We apologize for any inconvenience this may cause.

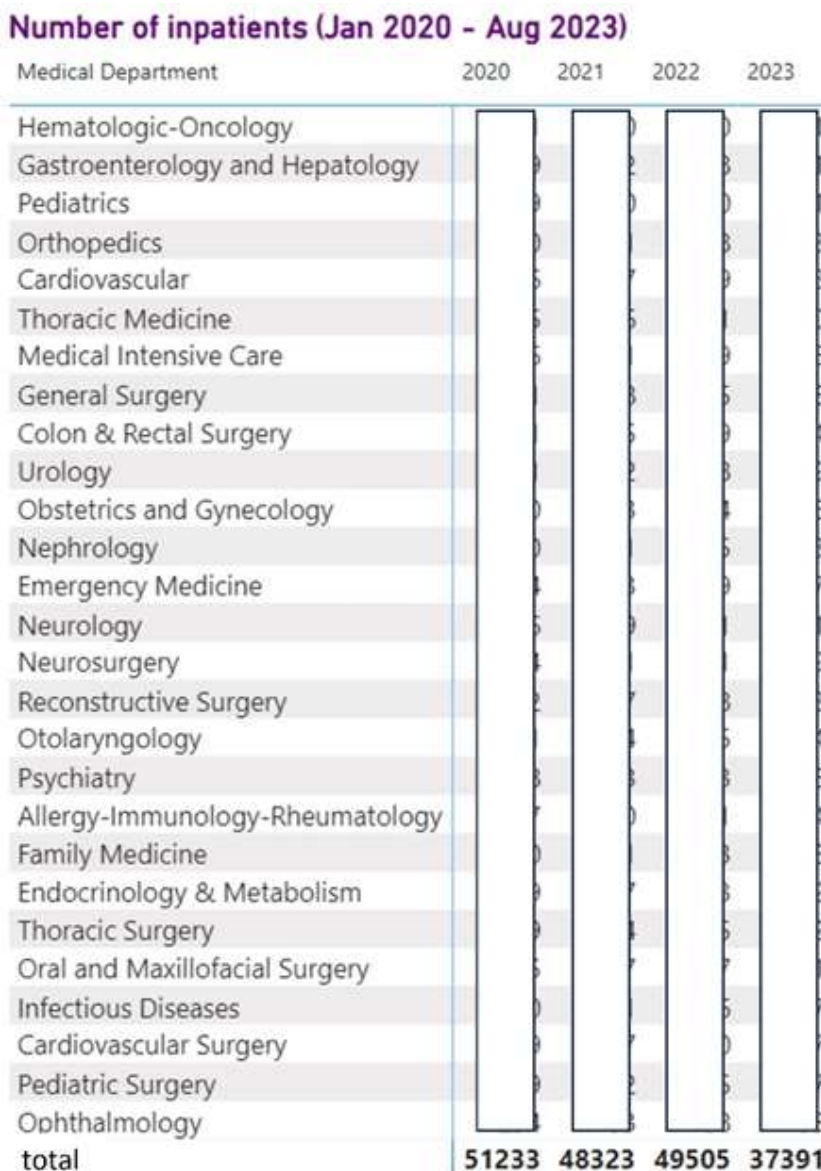

Figure 2: Number of inpatients (Jan 2020 - Aug 2023).



### Number of outpatients (Jan 2020 - Aug 2023)

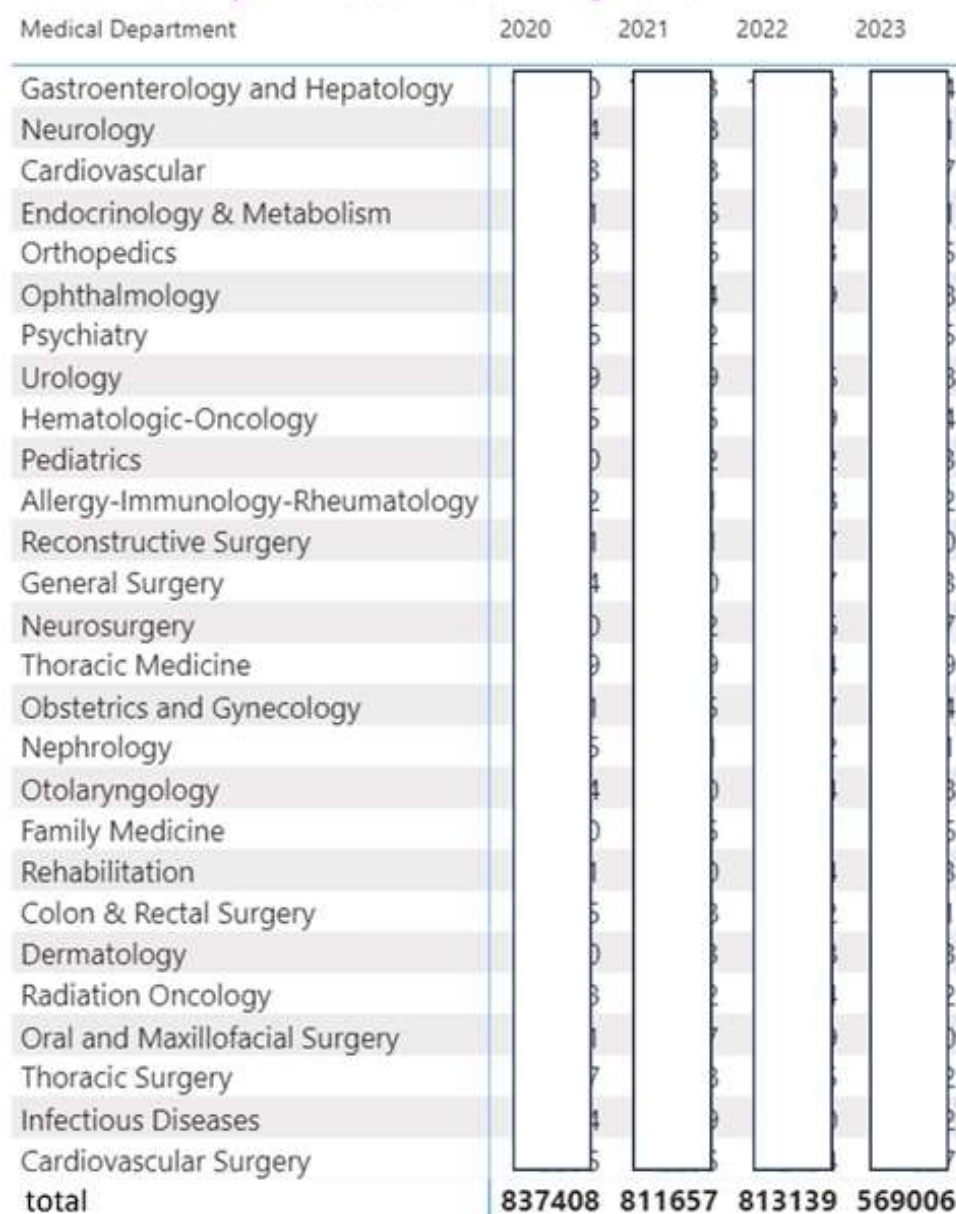

Figure 3: Number of outpatients (Jan 2020 - Aug 2023)

**CT examination rate for outpatients (Jan 2023 - Aug 2023)**

Medical Department	202301	202302	202303	202304	202305	202306	202307	202308
Thoracic Surgery	%	%	%	%	%	%	%	%
Hematologic-Oncology	%	%	%	%	%	%	%	%
Thoracic Medicine	%	%	%	%	%	%	%	%
Radiation Oncology	%	%	%	%	%	%	%	%
Colon & Rectal Surgery	%	%	%	%	%	%	%	%
Cardiovascular Surgery	%	%	%	%	%	%	%	%
Urology	%	%	%	%	%	%	%	%
Otolaryngology	%	%	%	%	%	%	%	%
Neurosurgery	%	%	%	%	%	%	%	%
Neurology	%	%	%	%	%	%	%	%
General Surgery	%	%	%	%	%	%	%	%
Oral and Maxillofacial Surgery	%	%	%	%	%	%	%	%
Gastroenterology and Hepatology	%	%	%	%	%	%	%	%
Orthopedics	%	%	%	%	%	%	%	%
Reconstructive Surgery	%	%	%	%	%	%	%	%
Obstetrics and Gynecology	%	%	%	%	%	%	%	%
Medical Intensive Care	%		%	%	%			%
Nephrology	%	%	%	%	%	%	%	%
Pediatric Surgery	%	%	%	%	%	%	%	
Psychiatry	%	%	%	%	%	%	%	%
Family Medicine	%	%	%	%	%	%	%	%
Cardiovascular	%	%	%	%	%	%	%	%
Pediatrics	%	%	%	%	%	%	%	%
Allergy-Immunology-Rheumatology	%	%	%	%	%	%	%	%
Infectious Diseases	%		%	%				%
Endocrinology & Metabolism	%		%	%	%	%		%

Figure 4-1: Average monthly CT examination rate for outpatients (Jan 2020 - Aug 2023)

### Average monthly CT examination rate for outpatients (Jan 2020 - Aug 2023)

Medical Department	2020	2021	2022	2023
Thoracic Surgery	%	%	%	%
Hematologic-Oncology	%	%	%	%
Nuclear Medicine	%	%	%	%
Radiation Oncology	%	%	%	%
Thoracic Medicine	%	%	%	%
Colon & Rectal Surgery	%	%	%	%
Otolaryngology	%	%	%	%
Urology	%	%	%	%
Neurosurgery	%	%	%	%
Cardiovascular Surgery	%	%	%	%
General Surgery	%	%	%	%
Neurology	%	%	%	%
Oral and Maxillofacial Surgery	%	%	%	%
Gastroenterology and Hepatology	%	%	%	%
Medical Intensive Care	%	%	%	%
Geriatric Medicine	%	%	%	%
Orthopedics	%	%	%	%
Reconstructive Surgery	%	%	%	%
Pediatric Surgery	%	%	%	%
Obstetrics and Gynecology	%	%	%	%
Nephrology	%	%	%	%
Infectious Diseases	%	%	%	%
Psychiatry	%	%	%	%
Family Medicine	%	%	%	%
Pediatrics	%	%	%	%

Figure 4-2: CT examination rate for outpatients (Jan 2020 - Aug 2023)

**Average monthly CT examination rate for inpatients (Jan 2020 - Aug 2023)**

Medical Department	2020	2021	2022	2023
Surgical Intensive Care			%	%
Neurology	%	%	%	%
Neurosurgery	%	%	%	%
Cardiovascular Surgery	%	%	%	%
General Surgery	%	%	%	%
Medical Intensive Care	%	%	%	%
Infectious Diseases	%	%	%	%
Gastroenterology and Hepatology	%	%	%	%
Thoracic Surgery	%	%	%	%
Colon & Rectal Surgery	%	%	%	%
Oral and Maxillofacial Surgery	%	%	%	%
Thoracic Medicine	%	%	%	%
Endocrinology & Metabolism	%	%	%	%
Urology	%	%	%	%
Nephrology	%	%	%	%
Orthopedics	%	%	%	%
Allergy-Immunology-Rheumatology	%	%	%	%
Otolaryngology	%	%	%	%
Pediatric Surgery	%	%	%	%
Hematologic-Oncology	%	%	%	%
Ophthalmology	%		%	
Reconstructive Surgery	%	%	%	%
Cardiovascular	%	%	%	%
Family Medicine	%	%	%	%
Psychiatry	%	%	%	%

Figure 5-1: Average monthly CT examination rate for inpatients (Jan 2020 - Aug 2023)

### CT examination rate for inpatients (Jan 2023 - Aug 2023)

Medical Department	202301	202302	202303	202304	202305	202306	202307	202308
Surgical Intensive Care		%			%			
Neurosurgery	%	%	%	%	%	%	%	%
Neurology	%	%	%	%	%	%	%	%
Cardiovascular Surgery	%	%	%	%	%	%	%	%
General Surgery	%	%	%	%	%	%	%	%
Medical Intensive Care	%	%	%	%	%	%	%	%
Gastroenterology and Hepatology	%	%	%	%	%	%	%	%
Oral and Maxillofacial Surgery		%	%	%	%	%	%	%
Colon & Rectal Surgery	%	%	%	%	%	%	%	%
Nephrology	%	%	%	%	%	%	%	%
Thoracic Medicine	%	%	%	%	%	%	%	%
Allergy-Immunology-Rheumatology	%	%	%	%	%	%	%	%
Thoracic Surgery	%	%	%	%	%	%	%	%
Urology	%	%	%	%	%	%	%	%
Infectious Diseases	%	%	%	%			%	%
Endocrinology & Metabolism	%	%	%	%	%	%		%
Orthopedics	%	%	%	%	%	%	%	%
Hematologic-Oncology	%	%	%	%	%	%	%	%
Reconstructive Surgery	%	%	%	%	%	%	%	%
Otolaryngology	%	%	%	%	%	%	%	%
Pediatric Surgery		%	%		%		%	%
Cardiovascular	%	%	%	%	%	%	%	%
Psychiatry	%	%	%	%	%	%	%	%
Family Medicine	%	%	%	%	%	%	%	
Obstetrics and Gynecology	%	%	%	%	%	%	%	%
Pediatrics	%	%	%	%	%	%	%	%

Figure 5-2: CT examination rate for inpatients (Jan 2023 - Aug 2023)

### CONCLUSION

In conclusion, the alignment of computed tomography (CT) utilization with the genuine medical requirements of patients represents a critical nexus that hinges on meticulous considerations of both patient safety and medical costs. The comprehensive exploration of this relationship necessitates an ongoing commitment to observing and analyzing the long-term implications of CT utilization. The incorporation of a database for data analysis and medical management communication has proven instrumental in illuminating patterns and trends within specific patient categories. Notably, a discernible reduction in the frequency of examinations has been observed among certain patient cohorts. This observed trend highlights the dynamic nature of healthcare practices and the need for adaptive strategies that can be informed by robust data analytics. Assessing the appropriateness of examination frequency is a multifaceted endeavor requiring a nuanced understanding of evolving patient needs, technological advancements, and healthcare best practices. The feedback loop established through systematic observation allows for insights into the evolving landscape of medical imaging utilization. Continuous refinement of protocols and guidelines is essential to align CT utilization with the ever-changing landscape of patient care. Moreover, the provision of feedback to the medical department serves as a crucial component of healthcare management. The insights gained from long-term observation and analysis enable informed decision-making, facilitating proactive adjustments to examination protocols, resource allocation, and overall healthcare strategies. This iterative process ensures that CT resources are efficiently allocated and utilized, contributing to both optimal patient care and effective healthcare resource management. In summary, the integration of computed tomography into medical practices demands a vigilant and adaptive approach, with a continuous feedback loop that considers patient safety, evolving medical needs, and the economic implications of healthcare decisions. This study underscores the importance of ongoing research, data-driven insights, and collaborative efforts to enhance the alignment of CT utilization with the dynamic landscape of healthcare delivery.

## REFERENCES

- Jalaber et al., (2020). Chest CT in COVID-19 pneumonia: A review of current knowledge. *Diagnostic and Interventional Imaging*, (pp. 431-437).
- Royce, Winston W., et al. (1970) Managing the development of large software systems. In: *proceedings of IEEE WESCON*. (pp. 1-9).
- Purba R. & Sondang S., (2022). Design and build monitoring system for pregnant mothers and newborns using the waterfall model, *INTENSIF: Jurnal Ilmiah Penelitian dan Penerapan Teknologi Sistem Informasi*, 6(1), ( pp. 29-42).
- TRahayu et al., (2020). Application Report Process Of Islamic School Based On Pesantren Boarding Using Waterfall Model. *J. Phys. Conf. Ser.*, 1569(2), (pp. 022025).
- Withers, P. J. et al., (2021) X-ray computed tomography. *Nat., Rev. Methods Primers* 1(18).
- Narula et al., (2021) SCCT 2021 expert consensus document on coronary computed tomographic angiography: *a report of the Society of Cardiovascular Computed Tomography*.
- Becker et al., (2019) Microsoft power BI: extending excel to manipulate, analyze, and visualize diverse data. *Serials Review*, 45(3), (pp. 184–188).



## Configuration Analysis of Factors Influencing the Sales Performance of Live Streaming E-commerce based on the fsQCA Method

J.H. Chen <sup>1</sup>  
L.Z. Duan <sup>2</sup>  
Y.Y. Feng <sup>3,\*</sup>  
C.C. Yang <sup>4</sup>

\*Corresponding author

<sup>1</sup> Undergraduate student, Shenzhen University, Shenzhen, China, 2020045041@szu.edu.cn

<sup>2</sup> Postgraduate Student, Shenzhen University, Shenzhen, China, 2100132020@szu.edu.cn

<sup>3</sup> Associate Professor, Shenzhen University, Shenzhen, China, yuanyuef@szu.edu.cn

<sup>4</sup> Lecturer, Dongguan University of Technology, Dongguan, China, yangcc@dgut.edu.cn

### ABSTRACT

The commercial value of live-streaming e-commerce is enormous. It is no longer sufficient to focus on individual elements that create value. It is urgent to explore more meaningful combinations of factors to improve sales performance. Based on previous research on live streaming e-commerce and the fuzzy set qualitative comparative analysis method (fsQCA), this article analyzes the configuration of factors that cause high and low sales of goods through data collected online and summarizes several propositions. This study enriches the relevant theory of live-streaming e-commerce and aims to guide brand enterprises in improving the effectiveness of live-streaming e-commerce and consumers' experience by adjusting product selection and live-streaming strategies.

*Keywords:* Fuzzy set qualitative comparative analysis, live streaming e-commerce, configuration analysis, mixed methods, Oriental Selection.

### INTRODUCTION

Since 2016, live-streaming e-commerce functions have been launched on platforms such as Kuaishou, Douyin, and Taobao, and with the popularity of top anchors such as Li Jiaqi and Oriental Selection, they have gradually become known to people. During the epidemic in 2019, live-streaming e-commerce took the fast lane of development and became the most commonly used shopping method for many people who were isolated at home. Although the impact of the epidemic has gradually decreased, due to the convenience provided by live-streaming e-commerce for consumers and the shopping experience that traditional online shopping cannot compare, the live-streaming shopping habits developed by consumers during their stay at home are still retained. Live streaming e-commerce is still growing at a high rate, and it is estimated that the industry scale will approach 5 trillion yuan by 2023. Live-streaming e-commerce has huge business potential, but the question of how to make live-streaming e-commerce achieve the best sales performance remains to be solved.

Currently, scholars' attention to this new sales model of live-streaming e-commerce mainly focuses on the consumer perspective, exploring the factors that influence their consumption willingness and behavior (Wang Yi, 2023; Chen, C. C., & Lin, Y. C., 2018; Yin, S., 2022; Fei, M., Tan, H., Peng, X., 2021). Some scholars focus on the internal mechanism and find that the psychological contract of consumers when they shop in live streaming e-commerce plays an important role in their short-term consumption willingness (Wang Yi, 2023). In terms of antecedent variables, Chen, C. C., & Lin, Y. C. (2018) found that factors such as the flow experience in live streaming e-commerce can affect consumers' willingness to consume. In addition, when the live streamer has a high level of relevant professional knowledge, consumers tend to believe that the information is more credible and are more willing to follow the opinions of the live streamer (Fang, Y.-H., 2014) and interaction between anchors and consumers (Fei, M., Tan, H., Peng, X., Wang, Q., & Wang, L., 2021) have also been verified. Yin, S. (2022) found that consumers are influenced by a series of situational factors such as peer pressure when shopping in live streaming e-commerce. Tong, J. (2017) found that the vividness, interactivity, and authenticity of live streaming enhance consumers' purchase intention by influencing their sense of immediacy and trust.

In summary, the factors that affect consumer behavior are diverse, but most of the existing literature considers the mechanism of their effects from a single perspective. This has caused difficulties for enterprises and live-streaming practitioners to test various influencing factors comprehensively. Currently, analyzing the relationship between conditional variables and outcome variables from a multi-causal perspective based on configurational analysis has important practical significance. In addition, existing research mainly uses more subjective questionnaire surveys and less objective data to explore the configurational effects of various different elements in the complex scenario of live-streaming e-commerce.



Therefore, this study takes the top live streaming e-commerce anchor "Oriental Selection" as the research object and uses the machine learning mixed fsQCA method to compare and analyze the combination of seven research variables related to product sales performance to explore the key elements or combinations of elements that can improve live streaming e-commerce sales performance, such as from the perspective of the overall live streaming event (product type, product price, etc.) feedback given by consumers in live streaming e-commerce situations (such as likes, gifts, comments, etc.), and answer the question of how to adjust live streaming e-commerce strategies from the perspective of merchants to better improve live streaming e-commerce effects.

Specific research questions include:

RQ1: Are there differences in live streaming strategies for different types of products?

RQ2: How to adjust product prices and live streaming duration to improve product sales performance?

RQ3: How to increase product sales performance by guiding interaction between consumers and live streaming?

## LITERATURE REVIEW

### Elaboration Likelihood Model (ELM) Theory

ELM is an effective tool for Internet consumer information processing and decision-making processes (Petty, R. E., & Cacioppo, J. T., 1984), first proposed by American psychologists Richard E. Petty and John T. Cacioppo. The model believes that individuals process information through the central route and peripheral route, depending on their motivation and ability to process information. Previous studies have suggested that the more relevant an issue is to people, the more they rely on factual arguments and are less likely to believe the source of the news; on the other hand, in issues of low involvement, people are more likely to rely on the source of the news and are less concerned about whether the factual arguments are true (Petty, R. E., Cacioppo, J. T., & Schumann, D., 1983). The central route refers to when individuals have the motivation and ability to focus on information, they will think deeply about the persuasive communication information and form an attitude of agreement or disagreement. The peripheral route represents that individuals are unwilling or unable to think carefully about the arguments in persuasive communication and form an attitude influenced by surrounding clues.

Based on existing research and the ELM model, this study classifies seven variables into central route and peripheral route variables, exploring how specific factors in these two categories of variables are combined to affect the sales performance of live streaming e-commerce. Considering the specific situation of live streaming e-commerce, this study believes that the central route variables are the attributes related to the product that consumers receive. Therefore, this study sets the central route as the type of product, the price of the product, and the number of comments from consumers about the product; This study believes that the peripheral route variables are the attributes related to the perception of the anchor the live streaming. Therefore, the peripheral route is set as the duration of the product live broadcast, the number of likes, the number of gifts, and the number of comments from consumers about the anchor (Cheung, C. M., Lee, M. K., & Rabjohn, N., 2008; Lee J, Park D H, Han I., 2008; Park D H, Kim S., 2007; Park D H, Lee J, 2008). The following is a detailed explanation of the relevant variables:

### Central Route Variables

#### *Type of Product*

Previous research has shown that product type can have an impact on online consumers' decision-making (Jimenez F. R., Mendoza N. A., 2013; Xiao B., Benbasat I., 2011). Currently, the classification of live-streaming e-commerce products is usually based on search attributes into experience products and search products. Experience products require consumers to experience them to perceive their value, such as food and services; search products are products whose quality can be known through their parameters before consumers use them, such as electronic products and daily necessities. Because consumers have different perceptions of the value of these two types of products, it is believed that consumers' consumption motivations for them in the context of live-streaming e-commerce are not the same. Therefore, different product types should have different sales strategies.

#### *Price of Product*

During e-commerce live streaming, consumers may come across products of varying prices, such as tissues at relatively low prices and televisions at relatively high prices. Since the monetary loss incurred by an erroneous decision when purchasing a high-priced product is greater, consumers tend to perceive a higher level of risk when making such decisions. (Blankertz, Donald & Cox, Donald., 1969). (Campbell, M. C., & Goodstein, R. C., 2001) found that the higher the perceived risk of a product, the more cautious consumers are, and the more they pay attention to risk mitigation. In traditional e-commerce, businesses often use low-price promotions to attract consumers. In the context of live streaming e-commerce, promotions and cost-effectiveness are still important strategies for businesses. Previous research has shown that the reasonable application of price marketing strategies can strengthen transaction and relationship contracts with consumers and enhance consumer stickiness (Wang Yi, 2023). Therefore, it is believed that the price to some extent affects the sales of live-streaming e-commerce.

#### *Number of Comments from Consumers about the Product*

Previous research has the impact of visual reviews on consumers' purchase intention in e-commerce (Lin, T. M., Lu, K. Y., & Wu, J. J., 2012). However, previous research usually classified the bullet screen comments based on emotions into positive and negative categories, without studying the classification of bullet screen content from the perspective of the anchor and the

product as two different viewpoints. In bullet screens, consumers' comments on the product can intuitively reflect their real feedback and preferences for purchasing the product, indirectly reflecting the popularity of the product.

### **Peripheral Route Variables**

#### ***Duration of the Product Live Broadcast***

In previous studies, scholars have included live streaming duration as a relevant variable for live streaming sales performance (Shen Xiao, Lü Jun, 2023). The extension of the duration of the product live broadcast in live streaming e-commerce allows the anchor to provide more detailed explanations about the product and convey more information to consumers. However, a long broadcast may also make consumers feel bored with the live-streaming content, causing them to lose interest and their attention to decline, thereby affecting the sales of the product.

#### ***Number of Likes***

The number of likes is the total number of likes that a product live broadcast receives from consumers throughout the process, which can reflect consumers' love for the live streaming. In social settings, people convey emotions such as encouragement, care, and support to other network participants through likes (Rebecca A. Hayes, Caleb T. Carr & Donghee Yvette Wohn, 2016). The number of likes obtained during a product live intuitively reflects the degree of customer love for the product and the live streaming event. Generally speaking, the higher the number of likes obtained during a live-streaming event, the higher the sales performance of the product.

#### ***Number of Gifts***

Similar to likes, when consumers feel happy with the live-streaming experience, they may reward the anchor through gifts. The number of gifts reflects consumers' affirmation and appreciation for the live streaming, and they are usually more willing to purchase the live-streaming product, thereby creating higher sales performance.

#### ***Number of Comments from Consumers about the Anchor***

While watching the live streaming, consumers can interact with the anchor in real-time, and directly speaking in the chat box is the most convenient way to interact. The more comments consumers make about the live streaming, the deeper their perception of the live streaming characteristics. Previous research has shown that an anchor's physical attractiveness, social attractiveness, and professional ability influence consumers' intentions to follow the anchor's suggestions and recommend the anchor to others during live streams. (Zhu, L., Li, H., Nie, K., & Gu, C., 2021). Therefore, this study selects the number of comments from consumers about the anchor to represent the degree of attention to the anchor as one of the peripheral routes. Overall, the above research suggests that several factors related to live streaming sales of products and the perception of the anchor the live streaming may be correlated with high or low performance in live streaming e-commerce. The set of conditions explored in this study is detailed in the following hypothesis.

**Hypothesis 1:** Both product factors (such as type of product, price of product, and number of comments from consumers about the product) and the perception of the anchor the live streaming factors (such as duration of the product live broadcast, number of likes, number of gifts and number of comments from consumers about the anchor) are related to the high or low performance of live streaming e-commerce.

It should be emphasized that according to related research (De Crescenzo, V., Ribeiro-Soriano, D. E., & Covin, J. G., 2020), the causal recipes associated with low performance in live streaming e-commerce may not be a simple opposite of those associated with high performance, but may involve completely different recipes. However, in the absence of strong prior knowledge about the effects of configuration, it is difficult to determine how the recipes associated with high and low performance in live streaming e-commerce may differ. Therefore, based on these observations, we propose a second hypothesis.

**Hypothesis 2:** Different recipes are associated with the high or low performance of live streaming e-commerce.

## **DATA AND METHODOLOGY**

### **Data Preparation**

This study focuses on the "Oriental Selection" live streaming room on the Douyin platform. More than 50 hours of live-streaming data were collected from October 2022 to February 2023, and each time the live-streaming of the anchor's product marketing was extracted as a data sample. Three types of data were collected through third-party network live streaming data collection software: the number of comments, likes, and gifts from consumers; four types of data were recorded through manual methods: the type of product, price, total sales, and duration of the live broadcast. Finally, the BERT algorithm was used to classify the number of comments from consumers into two categories: "comments from consumers about the anchor" and "comments from consumers about the product." A total of eight data variables were obtained, including product type, product price, duration of the product live broadcast, number of likes, number of gifts, number of comments from consumers about the product, number of comments from consumers about the anchor, and total sales. A total of 500 samples were collected, and to avoid the influence of extreme values on the analysis results, the 50 samples with the highest sales and the 50 samples with the lowest sales were removed. Finally, 400 data samples were used for the QCA configurational analysis.

Table 1: Descriptive statistics of each variable.

	Maximum value	Minimum value	Mean value	Variance
the type of product(binary variable)	-			
Product price	788	9.9	81.3	4768.3
Duration of live-streaming demonstration by the anchor(s)	620	66	220	5620
Number of likes	500	46	184.5	4642
Number of gifts	1845	81	396.8	59355.9
The number of consumer comments on the product.	1239	9	121.8	14786.6
The number of consumer comments on the anchor.	1562	13	160.3	43639.8

## Data Processing and Classification

### Classification of Comment Data

In order to classify comment data as accurately as possible from the perspective of the commenting consumer, this study uses the BERT algorithm, which is currently more advanced in the field of NLP (Natural Language Process) text classification (Li Xiangdong, Sun Qianru, Shi Jian, 2023) and uses an 80% training set and 20% test set to train the algorithm. First, 2000 comments from consumers about the product and 2000 comments from consumers about the anchor were manually labeled. After manually labeling some of the data, the labeling is shown in Table 2.

Table 2: Comment Labels.

Consumer comments on the product.	Consumer comments on the anchor.
Why is there no more stock available?	Oriental Selection is really cost-effective.
This fish is delicious!	Mingming is really handsome.
Is there still any sheep milk available?	The anchor is so funny.
Can pregnant women eat it?	That was an excellent speech.
How many are in one pack?	The air of self-confidence and knowledge is evident in one's bearing.
.....	.....

After training the BERT algorithm and testing the test set, the test results were an accuracy rate of  $acc=0.955$  and  $f1=0.951$ , indicating that the algorithm accurately classified the comment data into "comments from consumers about the product" and "comments from consumers about the anchor."

## EXPERIMENTAL PROCEDURE

### Variable Calibration

Based on variable type, QCA can be divided into crisp set qualitative comparative analysis (csQCA), multi-value qualitative comparative analysis (mvQCA), and fuzzy set qualitative comparative analysis (fsQCA). The characteristics of the aforementioned result variables and conditional variables determine that the fsQCA method is more suitable for this study. fsQCA defines the degree of membership of the set by calibrating the original data, and then converts the fuzzy set data into a truth table, which has the dual advantages of qualitative and quantitative analysis.

This study determined the 95th percentile value, 50th percentile value, and 5th percentile value (Ragin C. C, 2009) as the completely membership point, cross point, and completely non-membership point, respectively. Among them, the product type is a binary variable and does not need calibration. Based on the three critical values, the result variables and conditional variables were calibrated, and the variables were converted into set concepts. By assigning values to the original data, a truth table was finally formed, and the calibration points for each variable are shown in Table 3.

Table 3: Variable Calibration.

Variable Type	Variable	completely membership point(95%)	Crosspoint(50%)	completely non-membership point(5%)
Result	Sales	35377.2	8643	2376
Conditional variable(Central route condition)	Product Type(binary variable)	Experience product is 1; Search product is 0		
	Product Price	198	59.9	19.9
	Number of consumer comments on the product	337	86	26
Conditional variable(Peripheral route condition)	Duration of live-streaming demonstration	0.004028	0.002396	0.001377
	Number of likes	314	175	92
	Number of gifts sent during the live-streaming	833	342	152
	Number of consumer comments on the anchor	554	89	24

### Model Analysis and Interpretation

#### Necessary Condition Analysis

In fsQCA, necessary condition analysis is used to test whether the result depends on a single variable, and the relationship between the result variable and the conditional variable can be judged by two indicators: consistency and coverage. Generally, when the consistency is greater than 0.9, it indicates that the conditional variable is a necessary condition. The necessary condition results of a single conditional variable in this study are shown in Table 4.

Table 4: Necessity Analysis.

Conditional variable	Consistency	Coverage
Experience product	0.808869	0.433520
Search product	0.191131	0.442533
High product price	0.660012	0.604868
Low product price	0.675547	0.559900
High number of consumer comments on the product	0.764583	0.741731
Low number of consumer comments on the product	0.588425	0.464457
High duration of live-streaming demonstration	0.794298	0.703044
Low duration of live-streaming demonstration	0.546732	0.468125
High number of likes	0.789000	0.718497
Low number of likes	0.557789	0.464982
High number of gifts sent during the live-streaming	0.805759	0.763047
Low number of gifts sent during the live-streaming	0.574718	0.462832
High number of consumer comments on the anchor	0.720646	0.725113
Low number of consumer comments on the anchor	0.625221	0.479509

From the results, none of the variables reached the ideal level of consistency of 0.9, indicating that no variable can be a necessary condition for the result variable. This suggests that the above variables need to work together through synergistic effects to promote sales in the context of live-streaming e-commerce. Individual factors have a weak impact on sales, so further configurational analysis of the conditional variables is needed to explore the configuration conditions that lead to high or low sales performance of the product.

However, the consistency of the central route experience products and the peripheral route number of gifts both exceeded 0.8, indicating that these two indicators have a relatively high impact on increasing sales of the product.

### **Configurational Analysis and Results**

Configurational analysis is the core of the QCA method, and its purpose is to explore the impact of different combinations of antecedent conditions on the result. The criterion for judging the configuration is the consistency level. Based on previous research and the fact that this study had a large sample size of 400 samples that eventually entered fsQCA, the consistency threshold was set to 0.8, and the frequency threshold was set to 2. According to previous research (Pappas, I. O., & Woodside, A. G, 2021; Du, Y., & Jia, L., 2017), the PRI threshold for exploring high-performance configurations was 0.75, and the PRI threshold for exploring low sales was 0.5. A truth table was constructed, and the simple solution and intermediate solution for high and low sales configurations were obtained, respectively.

The results of the configuration analysis are summarized in Tables 5 and 6.

Table 5: High Sales Revenue

Antecedent Conditions	High Sales Revenue Configuration					
	H1	H2	H3	H4	H5	H6
Type of roduct	●	●	●	⊗		
Product price				⊗	⊗	●
Number of comments on the product from consumers	●	●	●	⊗	●	⊗
Duration	●		●	●		●
Number of likes	●	●	●		●	●
Number of gifts	●	●		●	●	●
Number of comments on the anchor from consumers		●	●		●	●
Consistency	0.861017	0.870394	0.869243	0.850174	0.887333	0.865375
Coverage	0.499107	0.458277	0.443305	0.0702561	0.427235	0.323525
Unique Coverage	0.0630584	0.00783181	0.00725663	0.0144544	0.018888	0.0450922
Consistency of the solution	0.837065					
Coverage of the solution	0.667435					

Table 6: Low Sales Revenue Configuration.

Antecedent Conditions	Low Sales Revenue Configuration			
	NH1	NH2	NH3	NH4
Type of product		●	●	●
Product price			⊗	●
Number of comments on the product from consumers	⊗	⊗		⊗
Duration	⊗	⊗	⊗	
Number of likes	⊗	⊗	⊗	⊗
Number of gifts	⊗	⊗	⊗	⊗
Number of comments on the anchor from consumers	⊗		⊗	⊗
Consistency	0.938698	0.939062	0.92654	0.94315
Coverage	0.566051	0.487594	0.385087	0.329089
Unique Coverage	0.112226	0.0337692	0.0244952	0.0163745
Consistency of the solution	0.914953			
Coverage of the solution	0.64069			

Note: ● means the core condition exists, ⊗ means the core condition is missing, ● means the peripheral condition exists, ⊗ means the peripheral condition is missing, and blank indicates that the condition is not important to the configuration and is not studied. For product type, ● represents experience products, and ⊗ represents search products.

## Results Interpretation

### Interpretation of Necessary Condition Analysis Results

As shown in Table 3, the consistency of two antecedent conditions, experience products and high number of gifts, exceeded 0.8, while the consistency of search products was only 0.191. Compared with search products, experience products have greater unknowns in terms of quality and brand. Therefore, experience products need to eliminate the unknowns in the minds of consumers through behaviors such as the anchor's marketing and trial during the live streaming, and stimulate consumers' willingness to purchase through the anchor's personal charm.

Proposition 1: The live-streaming e-commerce scene is more conducive to the growth of sales of experience products.

### Interpretation of High Sales Configuration Results

The consistency of the configuration results obtained in this study was greater than 0.8, indicating that they can be considered good configuration results.

For experience products, there are three configurations, H1, H2, and H3, that leads to high sales results. There is no significant difference in product price for this product category. The horizontal analysis of the three configurations shows that they all have the same core condition, which is the number of comments and likes for the product.

As shown in Table 4, the three configurations differ in only one antecedent condition, namely, the number of comments from consumers about the anchor for H1, the duration of the live broadcast for H2, and the number of gifts for H3. It can be inferred that these three antecedent conditions can be replaced by each other in the process of achieving high sales of experience products in the live-streaming e-commerce context, as long as two of the three are present.



Proposition 2: In the live streaming e-commerce context, for experience products to achieve high sales, the central antecedent condition of the number of comments on the product and the peripheral antecedent condition of the number of likes must both be present. On this basis, the peripheral antecedent conditions of the number of comments from consumers about the anchor, number of gifts, and duration of the live broadcast can be mutually substituted.

For search products, there is only one configuration, H4, that leads to high sales. High sales of search products are often accompanied by low product prices, and the antecedent condition of comments on the product is missing, with only the duration of the live broadcast and the number of gifts present as antecedent conditions. The reason may be that consumers can easily perceive the value of search products through online comparisons and searches on different platforms, so search products often need to have a price advantage to attract consumers. Similarly, when it is easy to compare the quality of the product, consumers do not need to interact with the anchor to understand the product information, and their willingness to interact with the anchor will correspondingly decrease.

Proposition 3: When purchasing search products in live streaming e-commerce, consumers tend to buy low-priced products, and their willingness to interact with the anchor will decrease.

Paths H5 and H6 reveal the reasons for high sales of different product types from the dimensions of low price and high price. The difference is that for the low-priced product configuration H5, the antecedent condition of consumer evaluation of the product exists, but the duration of the live broadcast is not important. For the high-priced product configuration H6, achieving high sales requires more comments from consumers about the anchor and longer product marketing from the anchor, but fewer comments from consumers about the product. The reason may be that when consumers purchase high-priced products, they need to trust the anchor's personal charm and trust in the anchor, while for lower-priced products, consumers are more concerned about the opinions of other consumers about the product. In previous research (Botha, E., & Reyneke, M., 2016), scholars have pointed out that social presence has an influence on online purchase intention and online trust, but the relationship between social presence and purchase intention is moderated by the type of online product.

Proposition 4: When consumers purchase high-priced products in the live-streaming e-commerce context, they need longer product marketing time from the anchor and more comments from consumers about the anchor, while low-priced products require more opinions from other consumers about the product.

#### ***Interpretation of Low Sales Configuration Results***

The low sales configuration results first reveal that, under the premise of not limiting product type and price (NH1), the absence of antecedent conditions such as duration, comments, likes, and gifts can lead to low sales results. The other paths reveal different configuration results under the premise of differences in antecedent conditions of product type and price for experience products with no price requirement (NH2), low price (NH3), and high price (NH4).

NH2 has missing antecedent conditions for product comments, duration, likes, and gifts. NH3 has missing antecedent conditions for duration, likes, gifts, and comments about the anchor. NH4 has missing antecedent conditions for product comments, likes, gifts, and consumer comments about the anchor. Comparing the three configuration paths, it can be concluded that when consumers have high comments about low-priced experience products, they may also have lower sales; when the duration of the live broadcast for high-priced experience products is extended, it may also result in low sales; when consumers have high comments about the anchor for experience products, they may also have lower sales.

#### ***Robustness Test***

According to previous research (Hofstad T, 2019), robustness testing is a necessary process of the QCA method, and common methods include adjusting the consistency threshold, PRI consistency threshold, and frequency threshold to observe whether there are significant changes in the configuration results.

In this study, the consistency threshold was adjusted to test the robustness of the configuration results. The consistency threshold was adjusted from 0.8 to 0.7, and the results of high and low performance were consistent with the configuration results obtained before the adjustment. Therefore, it is considered that the research results obtained in this study have good robustness.

## **MAIN CONCLUSIONS AND MANAGERIAL IMPLICATIONS**

### **Theoretical Contributions**

This study has the following theoretical contributions. It is different from previous research that focuses on the impact of single factors on consumer shopping intentions in live-streaming e-commerce. Through the method of configuration analysis, this study analyzed different product types and prices from a multi-factor perspective and proposed different conclusions, similar to the use of digital live streaming in the tobacco industry (Pan Yigai, Tang Anni, Huang Liying, and others, 2023).

For the first time, the study classified bullet screen text based on content to represent consumers' attention to different subjects in the live streaming room. Previous research on the independent variable of consumer impulsivity has mainly used



questionnaires to investigate, while this study used recording methods to record the consumption amount of products to represent consumers' willingness to shop, which is more objective.

This study introduced ELM theory into the research field of live-streaming e-commerce and proposed that in the context of live-streaming e-commerce, consumers use product information as the central route and the message brought by the anchor as the peripheral route, expanding the application scope of ELM theory.

### **Managerial Implications**

The conclusions of this study can guide product selection, live streaming marketing process, and comment guidance in live streaming e-commerce management.

For product selection, the main focus should be on experience products such as food, with search products such as daily necessities as a supplement. Pay attention to the price of the product, and for search products, pay attention to attracting consumers to buy through promotional low prices.

For the live streaming marketing process, anchors should consciously spend more time on high-priced products, and for experience products and high-priced products, they should pay attention to interaction with consumers about the anchor's personal aspects to use the anchor's personal charm and credibility to attract consumers to purchase. However, for experience products, attention should be paid to conversation skills with consumers during live streaming, otherwise, it may lead to situations where time is invested but no return is received. For search products and low-priced products, the duration of the live-streaming marketing has a negative impact on sales performance, and the live-streaming marketing time should be appropriately reduced.

In terms of comment guidance, currently, in the live streaming room's comment area, live streaming staff guide comments, but mostly warn about violations and call on consumers to pay attention to the live streaming room. When explaining search products, we should relatively suppress the discussion of product attributes by consumers, and when explaining high-priced products, the staff should consciously lead discussions around the anchor.

### **Limitations and Future Research Prospects**

This study has some limitations:

This study selected "Oriental Selection" as a typical example of live streaming for information collection. However, on various platforms, many "internet celebrities" can earn considerable sales not because of the quality of the products but because of their high popularity, attracting consumers to purchase products through their trust in the anchor. The conclusions of this study may not explain the reasons for these situations. In future research, more different live streaming categories need to be distinguished.

This study selected the number of likes and gifts to represent consumers' satisfaction with the live-streaming experience and proposed that gifts are a different form of consumption behavior from purchasing products, but this study did not clarify the similarities and differences between these two different antecedent conditions. From the results, high gift numbers did not have a suppressive effect on consumer behavior. In future research, it is necessary to further clarify the psychological conditions in which consumers engage in liking and gift-giving behaviors and how to influence consumers' purchasing behavior.

When focusing on bullet screens, this study used the number of bullet screens to represent consumers' attention to the anchor or product, but did not clarify whether this attention is positive or negative. In future research, the bullet screen text classification can be refined through a secondary classification of anchor-product and positive-negative, so as to explore the mechanism of how consumers' use of bullet screens affects their willingness to purchase more comprehensively.

### **ACKNOWLEDGMENT**

This research was supported by the Philosophy and Social Sciences Planning Project of Guangdong Province (No. GD21CGL30, GD23XGL004), the Guangdong Basic and Applied Basic Research Foundation (No. 2023A1515012262), the Guangdong Graduate Education Innovation Program (No. 2021SFKC074), and the Co-construction project of the Philosophy and Social Sciences Planning Project of Guangdong Province.

### **REFERENCES**

- Blankertz, Donald & Cox, Donald. (1969). Risk Taking and Information Handling in Consumer Behavior. *Journal of Marketing Research*. 6. 110. 10.2307/3150012.
- Botha, E., & Reyneke, M. (2016). The influence of social presence on online purchase intention: An experiment with different product types. In *Looking Forward, Looking Back: Drawing on the Past to Shape the Future of Marketing: Proceedings of the 2013 World Marketing Congress* (pp. 180-183). Springer International Publishing. [https://doi.org/10.1007/978-3-319-24184-5\\_49](https://doi.org/10.1007/978-3-319-24184-5_49)
- Campbell, M. C. , & Goodstein, R. C. . (2001). The moderating effect of perceived risk on consumers' evaluations of product incongruity: preference for the norm. *Journal of Consumer Research*(3), 3.

- Chen, C. C., & Lin, Y. C. (2018). What drives live-stream usage intention? The perspectives of flow, entertainment, social interaction, and endorsement. *Telematics and Informatics*, 35(1), 293-303. <https://doi.org/https://doi.org/10.1016/j.tele.2017.12.003>
- Cheung, C. M., Lee, M. K., & Rabjohn, N. (2008). The impact of electronic word-of-mouth: The adoption of online opinions in online customer communities. *Internet research*, 18(3), 229-247. <https://doi.org/10.1108/10662240810883290>
- De Crescenzo, V., Ribeiro-Soriano, D. E., & Covin, J. G. (2020). Exploring the viability of equity crowdfunding as a fundraising instrument: A configurational analysis of contingency factors that lead to crowdfunding success and failure. *Journal of Business Research*, 115, 348-356. <https://doi.org/10.1016/j.jbusres.2019.09.051>
- Du, Y., & Jia, L. (2017). Configuration Perspective and Qualitative Comparative Analysis (QCA): A New Path for Management Research. *Management World*, (06), 155-167. doi:10.19744/j.cnki.11-1235/f.2017.06.012. (in Chinese).
- Fang, Y.-H. (2014). Beyond the Credibility of Electronic Word of Mouth: Exploring eWOM Adoption on Social Networking Sites from Affective and Curiosity Perspectives. *International Journal of Electronic Commerce*, 18(3), 67-102. <https://doi.org/10.2753/JEC1086-4415180303>
- Fei, M., Tan, H., Peng, X., Wang, Q., & Wang, L. (2021). Promoting or attenuating? An eye-tracking study on the role of social cues in e-commerce livestreaming. *Decision Support Systems*, 142, 113466. <https://doi.org/https://doi.org/10.1016/j.dss.2020.113466>
- Hofstad, T. (2019). QCA & the Robustness range of calibration thresholds: how sensitive are solution terms to changing calibrations?. *COMPASS Working Paper*, 2019-92. <http://www.compass.org/wpseries/Hofstad2019.pdf>.
- Jiménez, F. R., & Mendoza, N. A. (2013). Too Popular to Ignore: The Influence of Online Reviews on Purchase Intentions of Search and Experience Products. *Journal of Interactive Marketing*, 27(3), 226-235. <https://doi.org/10.1016/j.intmar.2013.04.004>
- Lee, J., Park, D. H., & Han, I. (2008). The effect of negative online consumer reviews on product attitude: An information processing view. *Electronic commerce research and applications*, 7(3), 341-352. <https://doi.org/10.1016/j.elerap.2007.05.004>
- Li, X., Sun, Q., & Shi, J. (2023). Automatic Classification of Product Review Texts Based on Short Text Expansion and BERT. *Journal of Information Resources Management*, (01), 129-139. doi:10.13365/j.jirm.2023.01.129. (in Chinese).
- Lin, T. M., Lu, K. Y., & Wu, J. J. (2012). The effects of visual information in eWOM communication. *Journal of research in interactive marketing*, 6(1), 7-26. <http://dx.doi.org/10.1108/17505931211241341>
- Pan Yigai, Tang Anni, Huang Liying, and others (2023). Research on the improvement path of digital live streaming activity based on configuration analysis. *Journal of Library and Information Science in Agriculture*, (02), 61-76. doi:10.13998/j.cnki.issn1002-1248.23-0086. (in Chinese).
- Pappas, I. O., & Woodside, A. G. (2021). Fuzzy-set Qualitative Comparative Analysis (fsQCA): Guidelines for research practice in Information Systems and marketing. *International Journal of Information Management*, 58, 102310. <https://doi.org/10.1016/j.ijinfomgt.2021.102310>
- Park, D. H., & Kim, S. (2008). The effects of consumer knowledge on message processing of electronic word-of-mouth via online consumer reviews. *Electronic commerce research and applications*, 7(4), 399-410. <https://doi.org/10.1016/j.elerap.2007.12.001>
- Park, D. H., & Lee, J. (2008). eWOM overload and its effect on consumer behavioral intention depending on consumer involvement. *Electronic commerce research and applications*, 7(4), 386-398. <https://doi.org/10.1016/j.elerap.2007.11.004>
- Petty, R. E., & Cacioppo, J. T. (1984). SOURCE FACTORS AND THE ELABORATION LIKELIHOOD MODEL OF PERSUASION. *Advances in Consumer Research*, 11, 668-672.
- Petty, R. E., Cacioppo, J. T., & Schumann, D. (1983). Central and peripheral routes to advertising effectiveness: The moderating role of involvement. *Journal of consumer research*, 10(2), 135-146. <https://doi.org/10.1086/208954>
- Ragin, C. C. (2009). *Redesigning social inquiry: Fuzzy sets and beyond*. University of Chicago Press.
- Rebecca A. Hayes, Caleb T. Carr & Donghee Yvette Wohn (2016) One Click, Many Meanings: Interpreting Paralinguistic Digital Affordances in Social Media, *Journal of Broadcasting & Electronic Media*, 60:1, 171-187, DOI: 10.1080/08838151.2015.1127248
- Shen Xiao, Lü Jun. (2023) Configuration Path Research on the Impact Factors of Officials' Live Streaming Sales Promotion Effect - Fuzzy Set Qualitative Comparative Analysis Based on 140 Cases. *Electronic Governance*. <http://kns.cnki.net/kcms/detail/11.5181.TP.20230904.0927.006.html>. (in Chinese)
- Tong, J. (2017) A Study on the Effect of Web Live Broadcast on Consumers' Willingness to Purchase. *Open Journal of Business and Management*, 5, 280-289. doi: 10.4236/ojbm.2017.52025.
- Wang Yi. (2023). Live-streaming e-commerce, psychological contracts and consumer stickiness. *Journal of Commercial Economics*, (06), 123-126. <https://kns.cnki.net/kcms/detail/detail.aspx?FileName=SYJJ202306028&DbName=CJFQ2023> (in Chinese).
- Xiao, B., & Benbasat, I. (2011). Product-Related Deception in E-Commerce: A Theoretical Perspective. *MIS Quarterly*, 35(1), 169-195. <https://doi.org/10.2307/23043494>
- Yin, S. (2020, 2020//). A Study on the Influence of E-commerce Live Streaming on Consumer's Purchase Intentions in Mobile Internet. *HCI International 2020 - Late Breaking Papers: Interaction, Knowledge and Social Media*, Cham. [https://doi.org/10.1007/978-3-030-60152-2\\_54](https://doi.org/10.1007/978-3-030-60152-2_54)
- Zhu, L., Li, H., Nie, K., & Gu, C. (2021). How do anchors' characteristics influence consumers' behavioural intention in livestream shopping? A moderated chain-mediation explanatory model. *Frontiers in Psychology*, 12, 730636. <https://doi.org/10.3389/fpsyg.2021.730636>

## COVID 19 and Information Technology: A Systematic Review

Hadeel Alharbi <sup>1</sup>  
John R. Hamilton <sup>2,\*</sup>  
Stephen J. Maxwell <sup>3</sup>

\*Corresponding author

<sup>1</sup> Professor, Computer Science and Software Engineering College, Hail University, h.alharbe@uoh.edu.au

<sup>2</sup> Chair Professor, James Cook University, Cairns, Australia, John.Hamilton@jcu.edu.au

<sup>3</sup> Researcher, Doctor, James Cook University, Cairns, Australia, Stephen.Maxwell@my.jcu.edu.au

### ABSTRACT

The COVID pandemic has driven innovations that have made information technology all-pervasive in the lives of most individuals. This systematic review seeks to determine the key themes that reflect these advances. The demographics of the publications reviewed were also examined. A total of 84 peer-reviewed and conference proceedings publications were selected from the years 2020-2022. NVivo 12 Plus was used to construct word relationship trees and a word frequency cloud. It was found that there are four main themes: information management; public health management; technological advances; and services. The word cloud revealed that data, health, learning, and social were the most frequently associated words with information technology and COVID. Most affiliations were based in the United States, with 79 authors, followed by China with 27 and India with 21 authors. The average number of authors on a publication was 3.59. Future research into the ethical impacts of online monitoring and real-world surveillance is needed. As data management systems are increasingly being used by corporations and governments to combat and restrict the spread of misinformation, who decides the truth needs to be clearly transparent?

*Keywords:* information management, NVivo, privacy, public health management, services, technological advances.

### INTRODUCTION

The global COVID pandemic has driven innovation in the integration of information technology (IT) that has redefined the individual's experiences with the cyber and digital world. Technological advances in the internet of things, cloud computing, machine learning and social networking have enabled the addressing of risks of encountering the disease while managing holistically the impacts on all aspects of an individual's life (Mehraeen et al., 2020; Hau et al., 2021). While information technology is critical to maintaining the lead in an operational and competitive environment, during the pandemic it has also led to fostering of a collaborative spirit (Mehraeen et al., 2020). Notwithstanding, the benefits of increased technological advancements, there have also been costs, perceived loss of privacy, over-regulation and disruption to supply chains and service provision (Ansari & Singh, 2021; Cherrington et al., 2021; Laxton et al., 2022).

The COVID pandemic has led to increased and regular global flows of information (Afzal, 2020). The rise of social media, coupled with an increased politically charged environment has had an exponential effect on the rise of misinformation (Afzal, 2020; Kulai et al., 2021; Wang et al., 2021). Emotionally charged messages tend to travel faster, carrying either positive or negative news, as individuals seek to be informed on the latest information (Lee et al., 2021; Zheng, 2022). Anti-quarantine comments and other disestablishmentalist content is able to be transmitted effectively by disruptors using social media (Karmi & Anderson, 2020) Furthermore, the rise and flood of misinformation and unrelated data can impede the flow of information on critical events (Afzal, 2020). The flood of mixed messages in the social media sphere has impacted social collective behaviour as individuals seek to protect their own health (Sutton et al., 2020).

The rise in the forced adoption of new technology requires effective change management practices if implementation is to be successful (McKeeby et al., 2021). An important consequence of the pandemic as a disruptor event is that it has driven increased innovation and acceptance of IT supported services, both at a government and individual level. Governments have introduced policies that has been at the forefront of driving innovation with support, both financially and through reductions in regulations, to fast-track innovations (Patrucco et al., 2021; Liu et al., 2021). Furthermore, researchers have turned to novel funding methods to gain the funds to drive research, such as crowdfunding (Ramadi & Nguyen, 2021).

There have been many innovations in the provision of government services as a consequence of restrictions in face-to-face contact due to COVID. The rise in e-government is not without risks, with a decline in corporate social responsibility and a rise in corruptive practices in jurisdictions with limited monitoring of governance practices in place (Avotra et al., 2021; Boban & Klarić, 2021). Governments have also sought to monitor social media to track societal attitudes (Sujiwo et al., 2021). Furthermore, as governments have sought to control human interactions to mitigate the spread of the pandemic greater surveillance has come at a cost to privacy and anonymity online, in the home and community, the loss of which may never be reclaimed (Indulkar et al., 2021).

Teaching and learning have undergone monumental changes during COVID in the way information is presented and classrooms are constructed (Sweidan et al., 2021; Chu, 2022). However, these pedagogical shifts in the design of curriculum due to the need for online learning have imposed unrealistic expectations on teachers and students (Hu & Lu, 2020). Another consequence that accompanied the rapid rise of online learning is that it has exposed children to the risks posed by the virtual world and a need for increased vigilance to maintain their well-being (Matkovic et al., 2021; Zhang et al., 2021). Similarly, there are risks to the integrity of the education system with identifying falsification and other malfeasance, as well as countermeasures (Barbosa et al., 2022; Weinberger & Bouhnik, 2021).

This review seeks to explore the current literature to investigate the key themes related to COVID and IT. These themes enable insights into the current research trends surrounding these topics through word associations. The key demographics of the literature will also be explored.

## METHODOLOGY

A systematic review of the literature using the meta-engine “One Search”. A total of 147 articles were identified using the terms “information technology + COVID” found in the title. Note that the search engine also incorporates the full reference to the article automatically to the search parameters. The only limiting qualification that was placed on the search was aimed at ensuring maximum currency, with only literature published in the years 2020- 2022. These dates represent the period of maximum impact globally of the COVID pandemic. A total of 63 articles were rejected: 3 books; 2 book reviews; 43 articles considered grey literature, this included trade magazines and newspaper articles; 4 articles that were only available in a language other than English; 4 articles were repeats of ones that had been included; 1 article had been retracted; and 6 were found to be unrelated – a historical comparative study (1), articles relating to metadata study methods (3), and those related to medical procedures (2). The remaining 84 articles were used in the review (Figure 1).

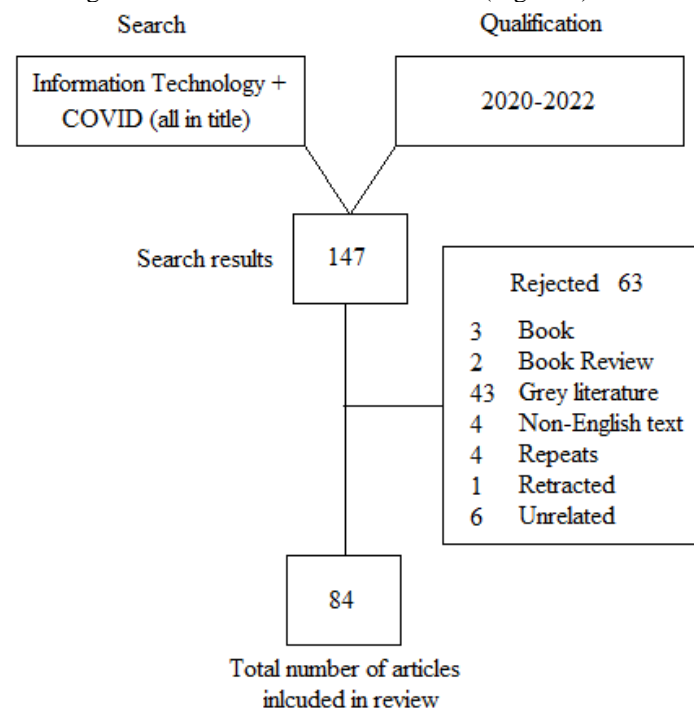

**Figure 1:** The process involved in the capture of the articles for this review using “One Search”.

Articles were loaded into NVivo 12 Plus. As well as the default omission of words in NVivo, such as articles, pronouns, prepositions and irregular verbs, this study also removed non-informative terms such as “DOI”, numbers and dates. The search terms “information” + “technology” + “COVID” were removed, these were contained in all papers and underpin all the relationships, thus dominating the word frequency word cloud. The NVivo thematic analysis was used with the 50 most frequent terms to identify any emerging themes, and the 50 most frequently used terms were shown in the generated word cloud in relative size to other words, words with higher usage are larger than those whose use is infrequent.

## RESULTS AND DISCUSSION

### Publication Demographics

There were an average of 3.59 authors per publication with the maximum number being 17 (Figure 2). Most papers included were written in 2021 with 45, 30 from journals and 15 conference proceedings (Figure 2). In 2022 a total of 7 papers were included, 5 from journals and 2 conference papers (Figure 2). A total of 32 papers were used from 2020, and 29 of these were conference proceedings with only 3 coming from journals (Figure 2). A total of 28 countries were listed as author affiliations, the United States having the largest representation with 79 authors, followed by China with 27 and India 21.

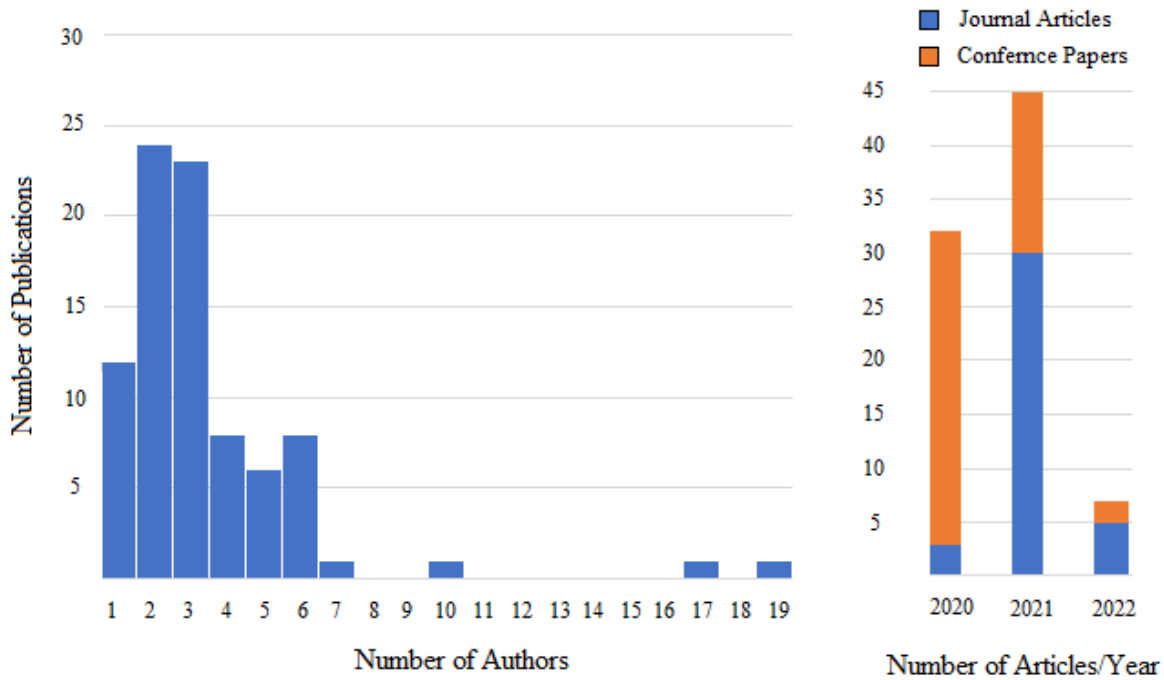
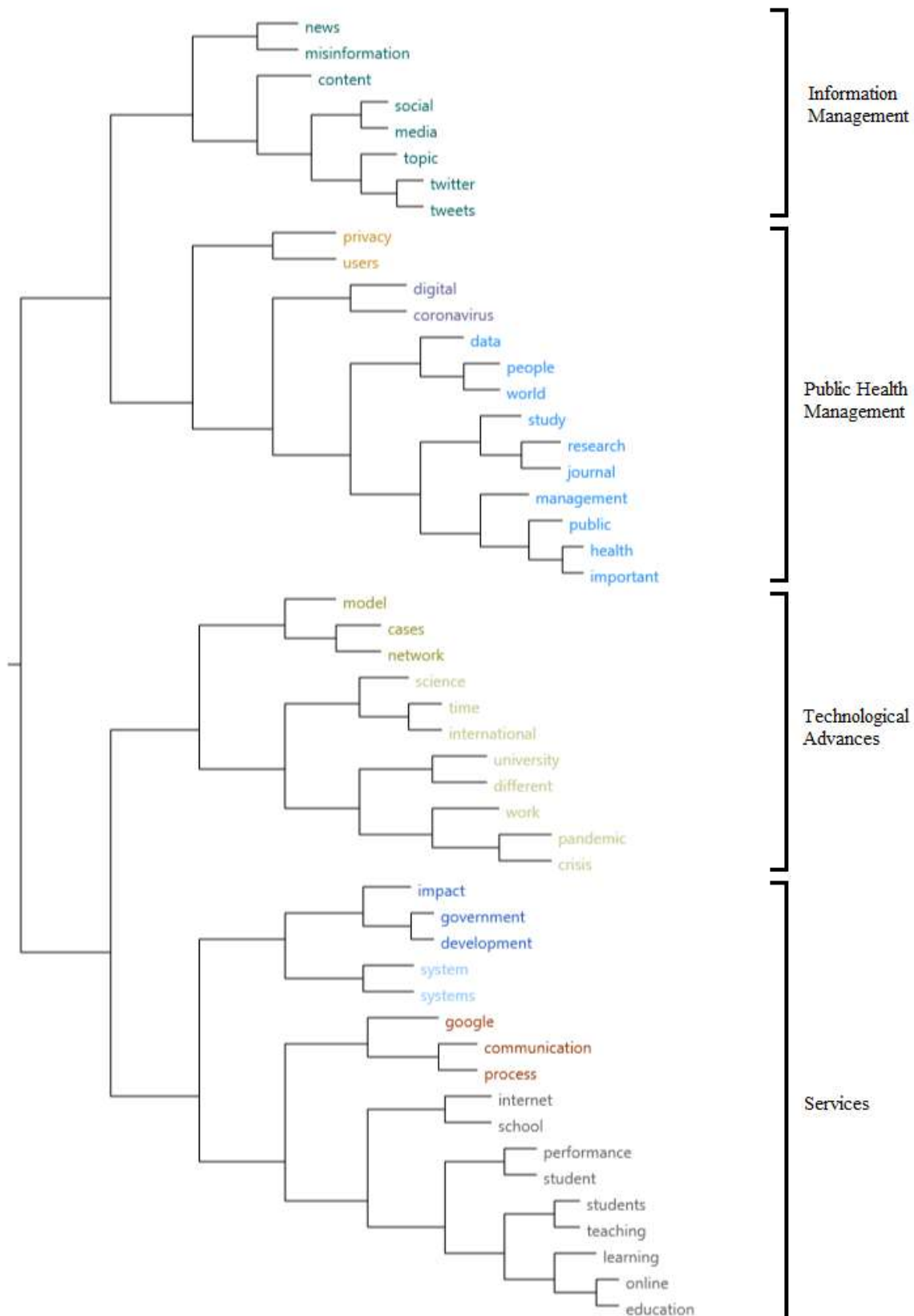

**Figure 2:** The number of articles used in the review showing the number of authors on each paper and the years and type of publication.

#### Thematic and Key Word Identification

Information technological innovations resulting from COVID disruptions can be classified into four thematic groups grounded in word clusters identified in NVivo: 1) the need to manage information; 2) management of public health; 3) technological advances, and 4) services (Figure 3).

The word cloud indicated that the most frequently used terms in connection with COVID and IT were “data”, “learning”, “social”, “health”, “research” and “pandemic” (Figure 4). These and less frequent words such as “students”, “public” and “model” are used to inform on the nature of the key identified themes.



**Figure 3:** Word relationships identified with NVivo showing the four main clusters which reflect the themes in the literature.





Fundamentally, there needs to be faith that the information collected is being used appropriately, and this relies on a level of trustworthiness in privacy by the society which is being monitored (Burdon & Wang, 2021; Wang et al., 2021).

Large global corporate actors, such as Apple and Google, have cooperated and developed applications that use Bluetooth on mobile devices to track proximity between individuals (Mandal et al., 2021). The use of tracing applications on mobile devices enables pandemic managers to quickly identify potential points of the transmission through contact tracing (Stahl, 2021; Tang et al., 2020). The use of deep learning-based human detection techniques enables data from surveillance cameras to be used to monitor social distancing practices has led to increased privacy concerns (Anari & Singh, 2021). Management of the disease was aided with the use of modelling infection growth estimation tools making IT critical in the decision-making process (Nazir et al., 2022).

### **Technological Advances**

Technological medical innovations can be classified into two thematic streams: first, the use of big data to effectively trace and track the spread of disease, reflected in the subgrouping of “model”, “cases” and “network”; and second, those that assist in the development of innovative medicines and understanding of the way in which the virus evolves underpinned by global cooperation which is dominated by research and the university sector, with the words “science”, “time”, “university”, “international” and “different” (Figure 3). While technological advances in IT were important, and these assisted in the development of models and the role that globally connected universities play in that process, the word cloud indicates that they were not a major term used in the literature (Figure 4).

The use of IT in modelling the spread of the pandemic involves multidimensional data handling to provide statistical data to enable effective decision-making (Rogers, 2020). The pandemic has led to significant advances in artificial intelligence systems that have machine learning techniques (Xiao, 2021). Most of these models are machine deep learning inductive-based algorithms, such as the Group Method of Data Handling (GMDH); however, the quality of the models varies (Cheng & Ludäscher, 2020; Acosta & Garcia-Zapirain, 2020; Moroz & Stepashko, 2022).

COVID also impacted many aspects of supply chain networks, a disruptor event that drove technological innovation (Cherrington et al. 2021; O’Connor et al., 2021; Prasetyo et al., 2021; Voumick et al., 2021). It saw firms pivot and remap into new expanded, enhanced, and more sustainable, competitiveness business models (Hamilton, 2020). In particular, food supply chain management was significantly impacted by COVID, particularly as many sections of that industry had historically entrenched transaction practices and were resistant to IT-driven transformational change (O’Connell et al., 2021). COVID revolutionised the farming sector, with increased uptake of information sharing, logistical planning, and resource exchange. Primary producers and distribution networks had to develop novel ways to transact, find new markets and novel ways of selling such as online ordering, creating websites, and increasing social media usage (O’Connell et al., 2021). Similarly, the use of cashless payments and other transactional technologies developed as part of the new wave of the internet of things reduced the contact between individuals and was seen as a means of reducing human physical interaction (Dookeeram et al., 2020). In addition, road traffic management systems have been upgraded to monitor flows of traffic to areas of potential high-risk gatherings (Ferreira et al., 2022).

Information technology aided through the provision of artificial intelligence and cloud services assisted in understanding and combatting the pandemic by rapidly processing large data sets and enabling the sharing of this information to a wide audience of transnational stakeholders (Laxton et al., 2021). This was achieved by facilitating rapid data preparation for decision-makers and clinicians (Nazir et al., 2022). This led to the formation of the COVIDCV system, an application that enables parties to upload their qualifications, this facilitates rapid identification of key personnel on a global scale (Raja et al., 2021).

In terms of identification of COVID cases, artificial intelligence programs, such as Segmentation Identification and Logarithmic Transformation of Local Binary Patterns, enable rapid detection of the disease (Islam & Matin, 2021; Lakshmi et al., 2022; Nazir et al., 2022). Information technology also assisted in understanding how the disease changes through classification through residual dense neural networking (Nazir et al., 2022). The use of computer tomography has improved clinical workflows enabling improved treatment times (Islam & Matin, 2021). IT innovations and modelling have enabled the investigation of comorbidities with COVID (Podder et al., 2021). Similarly, the ability to assess larger data sets, data mining, has enabled the assessment of vaccine side effects (You et al., 2021).

Information technological innovations were major tools used to combat COVID in a clinical setting through the rollout of telemedicine, service robots, wearable devices and 3D printing of medical supplies (Dey et al., 2021; Dookeeram et al., 2020; Mandal et al., 2021; Hau et al., 2021; Liu et al., 2021). COVID led to an international shortfall in essential personal protective equipment, and it was the use of high-quality 3D printers that were able to mitigate this shortage, and more importantly enable the rapid customisation to suit individual client specifications (Prasetyo et al., 2021). Another innovation was the rise of telemedicine and its role as a means of measuring social distancing while retaining standards in healthcare (Dey, 2021; Dey et al., 2021). There have been advances in automated information retrieval systems which allow individuals to access information regarding specific topics using verbal queries (Cuenca & Morocho-Yunga, 2021).

## Services

The impact on innovation in service provision is reflected in two thematic ways: first, the government provision of services, highlighted by the word clustering of “impact”, “government” and “development”, which was closely tied to “system” and “systems”; and second, more broadly the move to online learning in education and the word clustering of “school”, “internet”, “teaching”, “online”, “performance”, “learning” and “student” (Figure 3). The term “learning” and “online” were prominent in the word cloud, highlighting the importance given to the research of online learning and teaching and its impact on student performance (Figure 4).

The use of IT systems allows secure and effective information sharing too many operational units within the government in real time (Popescu et al., 2021). However, it is important to recognise that not all members of the community are IT literate, and this lack of knowledge is particularly prevalent in the elderly and disadvantaged, further limiting their access to government services (Feldberg et al., 2021). Data literacy should be therefore seen as a social responsibility where data literacy is seen as a right, and to enable this, those people are often charged with the information provided to be trained effectively (Rubenstein et al., 2021; Radinsky & Tabak, 2022).

Information technology in the delivery of educational services to those in lockdown situations was critical to maintaining a functional educational system faced with the provision of a curriculum based on remote learning to a culturally diverse audience often using different platforms (Januar et al., 2020; Laxton et al., 2022; Williams et al., 2021; Wiyono et al., 2021; Desyanty et al., 2022). Student and teacher competency in the use of IT educational platforms is not uniform, and the level of computer literacy can have significant impacts on the learning outcomes for those who lack the competency or required tools such as Zoom (Barona & Ramirez, 2021; Delgado et al., 2021; Friedenthal, 2021; Sharma & Alvi, 2021; Pinto et al., 2022). Furthermore, students who study from home can feel isolated and emotionally vulnerable; this affects their academic performance, and the role of IT systems through the provision of virtual classrooms and interactive learning platforms and mediates this isolation (Laxton et al., 2020; Gopal et al., 2021; Karsen et al., 2021; Lim & Lee 2021; Poole & Zhang, 2021). The use of online applications, such as “Google Meet” and “Google Classroom”, have achieved effective learning outcomes even in the teaching of physical activities (Tănasă & Vizitiu, 2020; Ceci et al., 2021; Sharda & Bajpai, 2021). However, the emotional intelligence of the teacher can significantly impact on the effectiveness of online teaching regardless of the tools at hand (Leonardo, 2020; Kunda and Bei, 2021).

## LIMITATIONS

However, there needs to be a caveat in respect of the research that has been utilised in this review, with much of the infrastructure and finances needed to implement many of the IT innovations highlighting the disjunct in financial and technological capabilities between the developed and developing world economies (Dookeeram et al., 2020).

## FUTURE RESEARCH

There is an ongoing need to explore how social media is used by governments to mediate their policies based on information gleaned from online discussions and posts. This involves a level of monitoring of these sites by governments and has implications for privacy. Much is now being written about combatting misinformation, but little is known about who makes the decisions on what is the truth, and what exactly is being censored. This lack of transparency has significant implications for the restriction of information management and sharing on a global scale.

Furthermore, research into the impact on long-term privacy of individual citizens is under threat through the increase in surveillance that monitors behaviour, often accompanied by recognition systems, many of which were purported to be temporary health management actions by the government. Studies on the ethical role of information technology developers, and their corporate responsibility to the citizens of the state also need to be explored. The literature is heavily focused on the rapid development of control and monitoring systems, without full consideration of the implications for their use of them by authoritarian governments. Understanding the increased disadvantage of those who lack computer literacy or the tools to access services is a growing area of research. This is particularly the case as there is a move towards e-government.

## CONCLUSION

This systematic review found four key themes in the field of information technology and its relationship to COVID. First, information management and the need to manage large data derived from social media were key research foci, on how to deal with misinformation, however, little consideration was given to the fundamental right of free speech. Second, public health management in terms of monitoring the disease rates in the community was also linked to the monitoring of citizen behaviour in terms of compliance with government mandates. Third, technological advances in cloud-based research, intelligence systems for disease recognition, information sharing, and logistic support, coupled with practical innovations such as telemedicine and 3D printing of essential supplies were areas of rapid innovation during the pandemic. Finally, there was a move toward increased e-government and service provision, including a move towards online learning, both of which caused significant shifts in cultural and social practices. Therefore, while the pandemic has come at considerable costs to society, it has given rise to the rapid development of new and innovative technologies that will shape the lives of citizens globally well into the future.

## REFERENCES

- Acosta, M.F.J., & Garcia-Zapirain, B. (2020). Machine Learning Algorithms for Forecasting COVID 19 Confirmed Cases in America. *2020 IEEE International Symposium On Signal Processing and Information Technology* 1–6. <https://doi.org/10.1109/ISSPIT51521.2020.9408742>
- Afzal, W. (2020). What we can learn from information flows about COVID-19: Implications for research and practice. *Proceedings of the ASIST Annual Meeting*, 57(1), e245. <https://doi.org/10.1002/pra2.245>
- Anderson, M., Karami, A. & Bozorgi, P. (2020). Social media and COVID-19: Can social distancing be quantified without measuring human movements? *Proceedings of the ASIST Annual Meeting*, 57(1): e378. <https://doi.org/10.1002/pra2.378>
- Ansari, M.A. & Singh, D.K. (2021). Monitoring social distancing through human detection for preventing/reducing COVID spread. *BVICAM's International Journal of Information Technology*, 13(3), 1255-1264. <https://doi.org/10.1007/s41870-021-00658-2>
- Avotra, A.A.R.N., Chengang, Y., Marcelline, T.R.S., Asad, A. & Yingfei, Y. (2021). Examining the Impact of E-Government on Corporate Social Responsibility Performance: The Mediating Effect of Mandatory Corporate Social Responsibility Policy, Corruption, and Information and Communication Technologies Development During the COVID era. *Frontiers in Psychology*, 12, 737100-737100. <https://doi.org/10.3389/fpsyg.2021.737100>
- Barbosa, E., Melges, A. & Gil, H. (2022). Senior and access to the COVID Digital Certificate: : Application of an Iconographic Tutorial in the elderly in Castelo Branco, Portugal. *2022 17th Iberian Conference on Information Systems and Technologies (CISTI)*, 1-5. <https://doi.org/10.23919/CISTI54924.2022.9819981>
- Barona, C.B. & Ramirez, M.R. (2021). Effects of COVID 19 lockdown on the use of LMS platforms for virtual education. *2021 16th Iberian Conference on Information Systems and Technologies (CISTI)*, 1-6. <https://doi.org/10.23919/CISTI52073.2021.9476645>
- Boban, M. & Klaric, M. (2021). Impact of Covid 19 Pandemic on Digital Transformation of Public Administration in European Union. *2021 44th International Convention on Information, Communication and Electronic Technology (MIPRO)*, 1312-1317. <https://doi.org/10.23919/MIPRO52101.2021.9596678>
- Burdon, M. & Wang, B. (2021). Implementing COVID safe: The role of trustworthiness and information privacy law. *Law, Technology and Humans*, 3(1), 35-50. <https://doi.org/10.3316/informit.950076589645151>
- Bushuyev, S., Babayev, I., Bushuieva, V., Bushuyeva, N., Babayev & J., Bushuiev, D. (2021). Managing Project Success with “Infodemic” vs “Pandemic” Environment on the COVID - 19 Pandemic Case. *2021 IEEE International Conference on Smart Information Systems and Technologies (SIST)*, 1-7. <https://doi.org/10.1109/SIST50301.2021.9465939>
- Ceci, F., Lazoi, M., Lezzi, M., Mohammad, H. (2021). Fostering knowledge sharing in the innovation process: Information and communication technology-based versus face-to-face relationships. *Knowledge and Process Management*, 28(3),302-316. <https://doi.org/10.1002/kpm.1668>
- Chang, S., McKay, D., Caidi, N., Mendoza, A., Gomes, C. & Dedeoglu, C.E. (2020). From way across the sea: Information overload and international students during the COVID-19 pandemic. *Proceedings of the ASIST Annual Meeting*, 57(1), e289. <https://doi.org/10.1002/pra2.289>
- Chavez, N., Penarreta, M. & Armas, R. (2022). Eva in the Time of Covid in Ecuadorian Communication and Information Companies. *2022 17th Iberian Conference on Information Systems and Technologies (CISTI)*, 1-5. <https://doi.org/10.23919/CISTI54924.2022.9820536>
- Cheng, Y.-Y. & Ludäscher, B. (2020). Through the magnifying glass: Exploring aggregations of COVID-19 datasets by county, state, and taxonomies of U.S. regions. *Proceedings of the ASIST Annual Meeting*, 57(1), e355. <https://doi.org/10.1002/pra2.355>
- Cherrington, M., Airehrour, D., Madanian, S., Lu, J., Xu, Q. & Artiushkina, P. (2021). Remuneration Review: Risk, Planning, and Modelling beyond the Covid Crisis. *2021 IEEE 12th Annual Information Technology, Electronics and Mobile Communication Conference (IEMCON)*, 412-419. <https://doi.org/10.1109/IEMCON53756.2021.9623069>
- Chong, M. (2020). Network typology, information sources, and messages of the infodemic twitter network under COVID-19. *Proceedings of the ASIST Annual Meeting*, 57(1), e363. <https://doi.org/10.1002/pra2.363>
- Chong, M., Froehlich, T.J. & Shu, K. (2021). Racial Attacks during the COVID-19 Pandemic: Politicizing an Epidemic Crisis on Longstanding Racism and Misinformation, Disinformation, and Misconception. *Proceedings of the ASIST Annual Meeting*, 58(1), 573-576. <https://doi.org/10.1002/pra2.501>
- Chu, Y.B. (2022). A mobile augmented reality system to conduct electrical machines laboratory for undergraduate engineering students during the COVID pandemic. *Education and Information Technologies*, 27(6), 8519-8532. <https://doi.org/10.1007/s10639-022-10987-9>
- Cuenca, P. & Morocho-Yunga, J.C. (2020). Prototype for consultation of COVID information through a voice assistant. *2020 XV Conferencia Latinoamericana de Tecnologias de Aprendizaje (LACLO)*, 1-8. <https://doi.org/10.1109/laclo50806.2020.9381162>
- Delgado, E., Ore, M., Roca, K., Navarro, B. & Carlos, H. (2021). Retrospective Analysis of the Performance of Students from a Public University in Pre-COVID Time due to the Use of Information and Communication Technologies. *2021 9th International Conference on Information And Education Technology (ICIET 2021)*, 340-345. <https://doi.org/10.1109/ICIET51873.2021.9419646>
- Desyant, E.S., Astuti, W., Tirtaningsih, M.T., Kusumaningrum, D.E., Hikmah, R.K.A. & Zahra, T.F. (2022). Learner Facilitation to Develop Conscientizacao During the COVID Pandemic. *2022 2nd International Conference on Information Technology and Education (ICIT&E)*, 358-362. <https://doi.org/10.1109/ICITE54466.2022.9759892>

- Dey, J. (2021). Pivotal “New Normal” Telemedicine: secured psychiatric homeopathy medicine transmission in Post-COVID. *BVICAM's International Journal of Information Technology*, 13(3), 951-957. <https://doi.org/10.1007/s41870-021-00675-1>
- Dey, J., Sarkar, A. & Karforma, S. (2021). Newer post-COVID perspective: Teledental encryption by de-multiplexed perceptrons. *BVICAM's International Journal of Information Technology*, 13(2), 593-601. <https://doi.org/10.1007/s41870-020-00562-1>
- Dinh, L. & Parulian, N. (2020). COVID-19 pandemic and information diffusion analysis on Twitter. *Proceedings of the ASIST Annual Meeting*, 57(1), e252. <https://doi.org/10.1002/pr2.252>
- Dookeeram, D., Sammy, I. & Ali, K. (2020). Views on information technology during COVID 19. *Caribbean Medical Journal*, 1-3. <https://doi.org/10.48107/CMJ.2020.12.006>
- Fan, L., Yu, H. & Yin, Z. (2020). Stigmatization in social media: Documenting and analyzing hate speech for COVID-19 on Twitter. *Proceedings of the ASIST Annual Meeting*, 57(1), e313. <https://doi.org/10.1002/pr2.313>
- Feldberg, C., Crivelli, L., Tartaglini, M.F., Martin, M.E., Garcia, L.M., Hermida, P.D., Natalia, I., Somale, M.V., Sevlever, G. & Allegri, R.F. (2021). Impact of an intergenerational training program in the use of information and communication technologies for older adults who receive cognitive intervention in the context of a Covid-19 pandemic: Preliminary results. *Alzheimer's & Dementia*, 17(S7), e050594. <https://doi.org/10.1002/alz.050594>
- Ferreira, J., Braz, F., Baldo, F. & Goncalves, P. (2022). Analyzing the impact of the covid epidemic on beach access traffic. *2022 17th Iberian Conference on Information Systems and Technologies (CISTI)*, 1-7. <https://doi.org/10.23919/CISTI54924.2022.9820252>
- Friedenthal, M. (2021). How COVID Affected our Python Class at the Worcester Public Library. *Information Technology and Libraries*, 40(4), 1-4. <https://doi.org/10.6017/ITAL.V40I4.14041>
- Gopal, R., Singh, V. & A. (2021). Impact of online classes on the satisfaction and performance of students during the pandemic period of COVID 19. *Education and Information Technologies*, 26(6), 6923-6947. <https://doi.org/10.1007/s10639-021-10523-1>
- Hamilton, J.R. (2020). The Strategic Change Matrix and Business Sustainability across COVID 19. *Sustainability*, 12(15), 6026, (1-19). <https://doi.org/10.3390/su12156026>
- Hau, Y.S. & Chang, M.C. (2021). Healthcare information technology convergence to effectively cope with the COVID-19 crisis. *Health Policy and Technology*, 10(1), 27-28. <https://doi.org/10.1016/j.hlpt.2020.10.010>
- Hu, J. (2021). What Does Channel Say? Understanding How Social Media Social Capital Facilitates COVID-19-Related Information-Seeking and Opinion-Expression on Two Types of Platforms: User-oriented versus Content-oriented. *Proceedings of the ASIST Annual Meeting*, 58(1), 737-739. <https://doi.org/10.1002/pr2.546>
- Hu, Z. & Lu, W. (2020). PreKindergarten and kindergarten virtual school programs under COVID-19: A two-case comparative study. *Proceedings of the ASIST Annual Meeting*, 57(1), e338. <https://doi.org/10.1002/pr2.338>
- Indulkar, Y. (2021). Alleviation of COVID by means of Social Distancing & Face Mask Detection Using YOLO V4. *2021 International Conference on Communication Information and Computing Technology (ICCICT)*, 1-8. <https://doi.org/10.1109/ICCICT50803.2021.9510168>
- Islam, M.R. & Matin, A. (2020). Detection of COVID 19 from CT Image by The Novel LeNet-5 CNN Architecture. *2020 23rd International Conference on Computer and Information Technology (ICCIT 2020)*, 1-5. <https://doi.org/10.1109/ICCIT51783.2020.9392723>
- Januar, Rahmi, A., Andryadi, Hadini & Yudelnilastia (2021). Utilization of Information Technology Media and Communication in Distance Learning During the Covid 19 Pandemic. *Journal of Physics: Conference Series*, 1779(1), 12043. <https://doi.org/10.1088/1742-6596/1779/1/012043>
- Karami, A. & Anderson, M. (2020). Social media and COVID-19: Characterizing anti-quarantine comments on Twitter. *Proceedings of the ASIST Annual Meeting*, 57(1), e349. <https://doi.org/10.1002/pr2.349>
- Karsen, M., Kristin, D.M. & Pangestu, H. (2021). Evaluation on Student Engagement of Online Case-Based Learning and Flipped Learning During Covid 19 Pandemic (a case study approach). *2021 International Conference on Information Management and Technology (ICIMTech)*, 1, 271-276. <https://doi.org/10.1109/ICIMTech53080.2021.9534949>
- Kulai, A., Sankhe, M., Anglekar, S., Halbe, A. (2021). Emotion Analysis of Covid Tweets using FastText Supervised Classifier model. *2021 International Conference on Communication Information and Computing Technology (ICCICT)*, 1-6. <https://doi.org/10.1109/ICCICT50803.2021.9510156>
- Kundu, A. & Bej, T. (2021). COVID 19 response: An analysis of teachers' perception on pedagogical successes and challenges of digital teaching practice during new normal. *Education and Information Technologies*, 26(6), 6879-6879. <https://doi.org/10.1007/s10639-021-10503-5>
- Lakshmi, P., Sivagami, M. & Balaji, V. (2021). A novel LT-LBP based prediction model for COVID-CT images with Machine Learning. *2021 International Conference on Information Systems and Advanced Technologies (ICISAT)*, 1-5. <https://doi.org/10.1109/ICISAT54145.2021.9678196>
- Laxton, D., Cooper, L. & Younie, S. (2021). Translational research in action: The use of technology to disseminate information to parents during the COVID-19 pandemic. *British Journal of Educational Technology*, 52(4), 1538-1553. <https://doi.org/10.1111/bjet.13100>
- Lee, C.S., Goh, D.H., Tan, H.W., Zheng, H. & Theng, Y.L. (2021). Understanding the Temporal Effects on Tweetdiscussion of COVID-19 Vaccine. *Proceedings of the ASIST Annual Meeting*, 58(1), 768-770. <https://doi.org/10.1002/pr2.556>
- Leonardo, Z.V. (2020). Uso de la Tecnologia de la Informacion y Comunicacion en educacion virtual y su correlacion con la Inteligencia Emocional de docentes en el Ecuador en contexto COVID-19/Use of Information and Communication



- Technology in virtual education and its correlation with the Emotional Intelligence of Teachers in Ecuador in a COVID-19 context. *RISTI: Revista Ibérica de Sistemas e Tecnologias de Informaçã*, 40(40), 31-44. <https://doi.org/10.17013/risti.40.31-44>
- Lim, K.K. & Lee, C.S. (2021). Investigating Learner's Online Learning Behavioural Changes during the COVID-19 Pandemic. *Proceedings of the ASIST Annual Meeting*, 58(1), 777-779. <https://doi.org/10.1002/pr2.559>
- Liu, M., Bu, Y., Chen, C., Xu, J., Li, D., Leng, Y., Freeman, R.B., Meyer, E.T., Yoon, W., Sung, M., Jeong, M., Lee, J., Kang, J., Min, C., Song, M., Zhai, Y. & Ding, Y. (2022). Pandemics are catalysts of scientific novelty: Evidence from COVID-19. *Journal of the American Society for Information Science and Technology*, 73(8), 1065-1078. <https://doi.org/10.1002/asi.24612>
- Lloyd, A. & Hicks, A. (2020). Risk and resilience in radically redefined information environments; information practices during the COVID-19 pandemic. *Proceedings of the ASIST Annual Meeting*, 57(1), e336. <https://doi.org/10.1002/pr2.336>
- Lozić, J., Vojković, G. & Lozić, I. (2021). Analysis of the Financial Results of the Twitter Platform at the Beginning of Covid 19. *2021 44th International Convention on Information, Communication and Electronic Technology (MIPRO)*, 1420-1424. <https://doi.org/10.23919/MIPRO52101.2021.9597016>
- Mandal, R., D'Souza, R.M.C., Sharma, Z., Raj, L.A., Soman, B. & Mashusudana, K. (2021). A Contrasting of the Pernicious and the Salubrious: An Assessment of the Global Impact of the Covid 19 Pandemic on Technology and Information. *Annals of R.S.C.B.*, 25(2), 3513-352.
- Markovic, R., Vejmelka, L. & Kljucovic, Z. (2021). Impact of COVID 19 on the Use of Social Networks Security Settings of Elementary and High School Students in the Split-Dalmatia County. *2021 44th International Convention on Information, Communication and Electronic Technology (MIPRO)*, 1476-1482. <https://doi.org/10.23919/MIPRO52101.2021.9597179>
- McKeeby, J.W., Siwy, C.M., Revoir, J., Carlson, S.D., Joyce, M.D., Bailin, H., Frank, K.M., Krumlauf, M., Matlock, A.M., Lee, L.M., Sparks, M., Barnes, T., Liu, Y., Row, C.-H., Schmitt, J.M., Smith, D., Zelazny, A.M., Lonnerdal, D. & Coffey, P.S. (2021). Unveiling the silent threat among us: leveraging health information technology in the search for asymptomatic COVID 19 healthcare workers. *Journal of the American Medical Informatics Association :JAMIA*, 28(2), 377-383. <https://doi.org/10.1093/jamia/ocaa237>
- Mehraeen, M., Dadkhah, M. & Mehraeen, A. (2020). Investigating the capabilities of information technologies to support policymaking in COVID-19 crisis management; a systematic review and expert opinions. *European Journal of Clinical Investigation*, 50(11), e13391. <https://doi.org/10.1111/eci.13391>
- Moroz, O. & Stepashko, V. (2020). Case Study of the Ukraine Covid Epidemy Process Using Combinatorial-Genetic Method. *2020 IEEE 15th International Conference on Computer Sciences and Information Technologies (CSIT)*, 2, 17-20. <https://doi.org/10.1109/CSIT49958.2020.9322000>
- Nazir, T., Nawaz, M., Javed, A., Malik, K.M., Saudagar, A.K.J., Khan, M.B., Abul Hasanat, M.H., Al Tameem, A. & Al Kathami, M. (2022). COVID-DAI: A novel framework for COVID-19 detection and infection growth estimation using computed tomography images. *Microscopy Research and Technique*, 85(6), 2313-2330. <https://doi.org/10.1002/jemt.24088>
- O'Connell, C., Gay, R., McDonald, N. & Tayal, S. (2021). COVID Connections: Lessons from Adaptations to COVID-19 as Strategies for Building Food System Resilience. *Culture, Agriculture, Food and Environment*, 43(2), 123-136. <https://doi.org/10.1111/cuag.12276>
- Patra, R.K. & Pandey, N. (2021). Disinformation on novel coronavirus (Covid-19): A content analysis of news published on fact-checking sites in India. *DESIDOC Journal of Library & Information Technology*, 41(4), 275-283. <https://doi.org/10.14429/DJLIT.41.4.16556>
- Patrucco, A.S., Trabucchi, D., Frattini, F. & Lynch, J. (2021). The impact of Covid-19 on innovation policies promoting open innovation. *R&D Management*, 52(2), 273-293. <https://doi.org/10.1111/radm.12495>
- Pinto, M., Caballero Mariscal, D. & Segura, A. (2022). Experiences of information literacy and mobile technologies amongst undergraduates in times of COVID. A qualitative approach. *ASLIB Journal of Information Management*, 74(2), 181-201. <https://doi.org/10.1108/AJIM-10-2020-0333>
- Podder, N.K., Shill, P.C., Rana, H.K., Omit, S.B.S., Al Shahriar, M.M.H. & Azam, M.S. (2021), Genetic Effects of Covid 19 on the Development of Neurodegenerative Diseases. *2021 5th International Conference on Electrical Information and Communication Technology (EICT)*, 1-6. <https://doi.org/10.1109/EICT54103.2021.9733698>
- Poole, A.H. & Zhang, J. (2021). "It makes me sad": Archival Pedagogy in a Time of Covid-19. *Proceedings of the ASIST Annual Meeting*, 58(1), 315-326. <https://doi.org/10.1002/pr2.459>
- Popescu, V.F., Dragomir, F., Petre, R. & Bucata, G. (2021). Contribution to national security system, by creating an integrated open source portal with access to geo-information and telemedicine technologies for public health management (COVID 19 pandemic). *Romanian Journal of Information Technology and Automatic Control*, 31(4), 21-32. <https://doi.org/10.33436/v31i4y202102>
- Prasetyo, A., Abdillah, H., Wawan, W., Nurtanto, M., Kholifah, N. & Suyitno, S. (2021). How to the Need for Personal Protective Equipment (PPE) during the current Covid 19 Pandemic: Smart Products Solution. *2021 3rd East Indonesia Conference on Computer and Information Technology (EIconCIT)*, 309-313. <https://doi.org/10.1109/EIconCIT50028.2021.9431851>
- Radinsky, J. & Tabak, I. (2022). Data practices during COVID: Everyday sensemaking in a high-stakes information ecology. *British Journal of Educational Technology*, 53(5), 1221-1243. <https://doi.org/10.1111/bjet.13252>

- Raja, U., Chowdhury, N.S., Raje, R.R., Wheeler, R., Williams, J. & Ganci, A. (2021). COVID CV: A System for Creating Holistic Academic CVs during a Global Pandemic. *2021 IEEE International Conference on Electro Information Technology (EIT)*, 146-150. <https://doi.org/10.1109/EIT51626.2021.9491917>
- Ramadi, K.B. & Nguyen, F.T. (2021). Rapid crowdsourced innovation for COVID-19 response and economic growth. *Digital Medicine*, 4(1), 1-5.
- Reveilhac, M. & Blanchard, A. (2022). The framing of health technologies on social media by major actors: Prominent health issues and COVID-related public concerns. *International Journal of Information Management Data Insights*, 2(1), 100068. <https://doi.org/10.1016/j.ijime.2022.100068>
- Rogers, M. (2020). A case report: Challenges in COVID-19 modeling at a public health department. *Proceedings of the ASIST Annual Meeting*, 57(1), e426. <https://doi.org/10.1002/pra2.426>
- Rubenstein, E.L., Burke, S.K., D'Arpa, C., Lenstra, N. (2021). Health Equity and Small and Rural Public Libraries During COVID-19. *Proceedings of the ASIST Annual Meeting*, 58(1), 827-829. <https://doi.org/10.1002/pra2.577>
- Sathish, R., Manikandan, R.M., Priscila, S.S., Sara, B.V.J. & Mahaveerakannan, R. (2020). Report on the Impact of Information Technology and Social Media on Covid-19. *Proceedings of the Third International Conference on Intelligent Sustainable Systems*, 224-230. <https://doi.org/10.1109/ICISS49785.2020.9316046>
- Sharda, P. & Bajpai, M.K. (2021). Online Learning and Teaching using Google Classroom during the COVID-19 Pandemic. *DESIDOC Journal of Library & Information Technology*, 41(5),352-357. <https://doi.org/10.14429/djlit.41.5.16205>
- Sharma, A. & Alvi, I. (2021). Evaluating pre and post COVID 19 learning: An empirical study of learners' perception in higher education. *Education and Information Technologies*, 26(6), 7015-7032. <https://doi.org/10.1007/s10639-021-10521-3>
- Sohrabi, C., Alsafi, Z., O'Neill, N., Khan, M., Kerwan, A., Al-Jabir, A., Iosifidis, C. & Agha, R. (2020). World Health Organization declares global emergency: A review of the 2019 Novel Coronavirus (COVID-19). *International Journal of Surgery*, 71-76. <https://doi.org/10.1016/j.ijssu.2020.02.034>
- Southwell, B.G., Niederdeppe, J., Cappella, J.N., Gaysynsky, A., Kelley, D.E., Oh, A., Peterson, E.B. & Chou, W.-Y.S. (2019). Misinformation as a misunderstood challenge to public health. *American Journal of Preventative Medicine*, 57(2), 282-285. <https://doi.org/10.1016/j.amepre.2019.03.009>
- Stahl, B.C. (2021). Emerging technologies as the next pandemic?: Possible consequences of the Covid crisis for the future of responsible research and innovation. *Ethics and Information Technology*, 23(Suppl 1), 135-137. <https://doi.org/10.1007/s10676-020-09551-1>
- Sujiwo, B., Wibowo, A. & Saputro, D.R.S. (2021). Sentiment Analysis of Indonesian Government Policies In Handling Covid 19 Through Twitter Data. *2021 4th International Seminar on Research of Information Technology and Intelligent Systems (ISRITI)*, 453-457. <https://doi.org/10.1109/ISRITI54043.2021.9702784>
- Sutton, J., Renshaw, S.L. & Butts, C.T. (2020). COVID-19: Retransmission of official communications in an emerging pandemic. *PLoS One*, 15(9), e0238491. doi:<https://doi.org/10.1371/journal.pone.0238491>
- Idan, S.Z., Abu Laban, S.S., Alnaimat, N.A. & Darabkh, K.A. (2021). SEG-COVID: A Student Electronic Guide within Covid-19 Pandemic. *2021 9th International Conference on Information and Education Technology (ICIET 2021)*, 139-144. <https://doi.org/10.1109/ICIET51873.2021.9419656>
- Tan, M. & Chua, A.Y.K. (2021). Students' Motivations for Not Sharing Rumours during the COVID-19 Pandemic in Singapore. *Proceedings of the ASIST Annual Meeting*, 58(1), 842-844. <https://doi.org/10.1002/pra2.582>
- Tan, T., Huang, T., Wang, X. & Zuo, Z. (2020). A preliminary investigation of COVID-19 transmission in the United States by incorporating social media sentiments. *Proceedings of the ASIST Annual Meeting*, 57(1), e370. <https://doi.org/10.1002/pra2.370>
- Tănasă, B.I. & Vizitiu, E. (2020). Study on the technique of the game of badminton by using information technology during the pandemic covid -19 in students aged 10-12 years. *Annals of the "Ștefan Cel Mare" University: Physical Education and Sport Section - The Science and Art of Movement*, 13(2), 112-120. <https://doi.org/10.4316/SAM.2020.0215>
- Tang, R., Erdelez, S., May, E. & Zhang, Y. (2020). The state of practice of COVID-19 tracking systems: An inventory study. *Proceedings of the ASIST Annual Meeting*, 57(1), e397. <https://doi.org/10.1002/pra2.397>
- Voumick, D., Mim, I.J., Deb, P., Sutradhar, S., Salim, S.A., Sutradhar, K. & Khan, M.M. (2021). Development of A Web Based Covid Portal and Marketplace. *2021 IEEE 12th Annual Information Technology, Electronics and Mobile Communication Conference (IEMCON)*, 406-411. <https://doi.org/10.1109/IEMCON53756.2021.9623065>
- Wang, T., Guo, L. & Bashir, M. (2021). COVID-19 Apps and Privacy Protections from Users' Perspective. *Proceedings of the ASIST Annual Meeting*, 58(1), 357-365. <https://doi.org/10.1002/pra2.463>
- Wang, X., Zhang, M., Fan, W. & Zhao, K. (2022). Understanding the spread of COVID-19 misinformation on social media: The effects of topics and a political leader's nudge. *Journal of the American Society for Information Science and Technology*, 73(5), 726-737. <https://doi.org/10.1002/asi.24576>
- Weinberger, M. & Bouhnik, D. (2021). Factors for Online Identity Falsification among Israeli Students in the Era of COVID-19. *Proceedings of the ASIST Annual Meeting*, 58(1), 860-862. <https://doi.org/10.1002/pra2.589>
- Williams, H., Haynes, M. & Kim, J. (2021). Dual Teaching: Simultaneous Remote and In-Person Learning during COVID. *SIGITE 2021 - Proceedings of the 22nd Annual Conference on Information Technology Education*, 111-116. <https://doi.org/10.1145/3450329.3476867>
- Williams, H., Haynes, M. & Kim, J. (2021). Dual Teaching: Simultaneous Remote and In-Person Learning During COVID. In *Proceedings of the 22nd Annual Conference on Information Technology Education USB Stick (SIGITE '21)*, October 6–9, 2021, SnowBird, UT, USA. ACM, New York, NY, USA, 6 pp. <https://doi.org/10.1145/3450329.3476867>

- Wiyono, B.B., Indreswari, H. & Prestiadi, D. (2021). The Use of Technology-Based Communication Media in The Teaching-Learning Interaction of Educational Study Programs in The Pandemic of Covid 19. *2021 IEEE 11th International Conference on Electronics Information and Emergency Communication (ICEIEC)*, 1-5. <https://doi.org/10.1109/ICEIEC51955.2021.9463846>
- Wu, S. (2021). Understanding New Yorkers' Everyday Life Information Seeking Behavior in the Context of Coping with COVID-19. *Proceedings of the ASIST Annual Meeting*, 58(1), 866-868. <https://doi.org/10.1002/pra2.591>
- Xiao, Z. (2021). COVID 19 Mortality Rate Prediction based on Machine Learning Methods. *2021 IEEE International Conference on Computer Science, Electronic Information Engineering and Intelligent Control Technology (CEI)*, 169-177. <https://doi.org/10.1109/CEI52496.2021.9>
- Yang, S., Fichman, P., Zhu, X., Sanfilippo, M., Li, S. & Fleischmann, K.R. (2020). *The use of ICT during COVID-19. Proceedings of the ASIST Annual Meeting*, 57(1), e297. <https://doi.org/10.1002/pra2.297>
- Ye, Z., Mao, J., Liu, Y., Zhang, M. & Ma, S. (2020). Investigating COVID-19-Related query logs of Chinese search engine users. *Proceedings of the ASIST Annual Meeting*, 57(1), e424. <https://doi.org/10.1002/pra2.424>
- You, J., Shaik, N. & Chen, H. (2021). Data Mining on COVID-19 Vaccines: Side Effects. *Proceedings of the ASIST Annual Meeting*, 58(1), 869-871. <https://doi.org/10.1002/pra2.592>
- Zhang, Y., Tang, J. & Zhang, P. (2021). An Exploratory Study on Chinese Preteens' Internet Use and Parental Mediation during the COVID-19 Pandemic. *Proceedings of the ASIST Annual Meeting*, 58(1), 875-877. <https://doi.org/10.1002/pra2.594>
- Zheng, H., Goh, D.H., Lee, E.W.J., Lee, C.S. & Theng, Y. (2022). Understanding the effects of message cues on COVID-19 information sharing on Twitter. *Journal of the American Society for Information Science and Technology*, 73(6), 847-862. <https://doi.org/10.1002/asi.24587>



## Decoding Business Applications of Generative AI: A Bibliometric Analysis and Text Mining Approach

May Ying Wang<sup>1</sup>  
Pengqi Wang<sup>2,\*</sup>

\*Corresponding author

<sup>1</sup> Associate Professor, Beijing Normal University-Hong Kong Baptist University United International College, Zhuhai, China, ywang@uic.edu.cn

<sup>2</sup> M. Phil. Student, The Hong Kong University of Science and Technology (Guangzhou), Guangzhou, China, pwang294@connect.hkust-gz.edu.cn

### ABSTRACT

The integration of Generative AI into business and management stands out as a pivotal transformation. This paper employs bibliometric analysis to scrutinize academic perspectives on the applications of Generative AI across diverse business research fields. Concurrently, text mining based on tweets and websites is deployed to probe cutting-edge industry applications of Generative AI in business and management. The latent Dirichlet allocation (LDA) topic modeling method unveils the profound potential of Generative AI, i.e. 1) creating new interfaces for service providers and personalized experience; 2) creating new content to augment human creativity; 3) improving efficiency and productivity, and 4) enabling more new applications, business models and use in the practical business applications. Delving into the contemporary research topics in information systems, marketing, management, and other business research, this study undertakes a comprehensive bibliometric and thematic analysis to integrate findings from both contemporary academic research fields and business application spheres to identify the research gap and explore future research context in GenAI. Moreover, this study underscores the ethical and practical challenges that emerge, advocating for interdisciplinary study on GenAI. The paper concludes by providing suggestions for future research, underscoring the importance of combining technological expertise with a human-centered approach.

*Keywords:* Generative AI, GenAI applications, bibliometric review, text mining

### INTRODUCTION

Generative AI (GenAI) has emerged as a transformative force across the entire spectrum of business and management. Since its advent, GenAI has demonstrated a capacity to reshape traditional business operations and strategies, offering capabilities that extend beyond those of conventional AI technologies (Van Dis et al., 2023). Distinctive features of GenAI, such as hyper-personalization, dynamic content creation, and enhanced automation, have set the stage for innovations that transcend traditional marketing paradigms. A survey by McKinsey illuminated the rapid adoption and reliance on GenAI among business leaders in the business operation and management aspect. The study revealed that a staggering 90 percent of business leaders across various sectors anticipate integrating GenAI solutions into their regular operations within the next two years (Deveau et al., 2023). Concurrently, a report by Boston Consulting Group (BCG) highlighted the economic advantages of GenAI, noting an observed productivity boost of 30%, attributed to the technology's cost-effectiveness and user-friendly nature (Ratajczak et al., 2023).

GenAI has the potential to significantly influence how businesses operate and innovate. It is anticipated to reshape processes ranging from lead identification through analytical systems, to enhancing information systems-backed marketing strategies that include AI-driven A/B testing and advanced SEO techniques. The system's potential also aligns with user-centric services, integrating tools like chatbots and virtual assistants, enabling dynamic content generation for digital platforms such as emails and websites, and providing real-time analytical insights (Paul et al., 2023). Within the information systems (IS) domain, applications like dynamic audience targeting for optimized selling recommendations and continuous churn modeling underscore the system's sophistication. Furthermore, GenAI's capabilities are being integrated into automated IS workflows, impacting areas such as product design systems and campaign nurturing platforms (Deveau et al., 2023). The technology is poised to reshape multifaceted business processes—from supply chain optimization and human resource management to platforms enabling strategic decision-making. As GenAI continues to integrate with a multitude of business tools and platforms, its transformative potential becomes even more apparent. This underscores the pressing need for an exhaustive exploration and comprehension of its applications, implications, and future trajectory across the broader business landscape.

While GenAI's transformative potential is evident, the academic landscape reflecting its application in business and management is still in its nascent stages. Given the novelty of GenAI, there is a growing number of literature that delves into its applications within the broad ambit of business and management. In light of the growing need for nuanced understanding, this study adopts a methodologically diverse approach to explore Generative AI's role in business and management. Grounded in bibliometric analysis, our primary aim is to systematically examine scholarly contributions to this burgeoning field. Simultaneously, we leverage text mining techniques to investigate the frontier applications of Generative AI within the industry. By amalgamating insights gleaned from both academic and practical perspectives, the article aspires to provide a nuanced panorama of the extant research and applications.

The review in this study based on bibliometric analysis and text mining not only aids in understanding the evolutionary trajectory of research on GenAI's business applications but also sheds light on potential gaps between the existing literature and practical arenas. Recognizing these gaps is of paramount importance, as it allows for the identification of areas ripe for further exploration. Conclusively, this article endeavors to offer recommendations for future research, ensuring that subsequent academic pursuits in this domain are both meaningful and impactful.

## METHODOLOGY

In the context of our study, this Bibliometric approach, introduced by Pritchard (1969) is particularly pertinent to the rapidly evolving domain of GenAI in business and management. It offers a suite of analytical tools for assessing publication trends within a domain. This methodology facilitates the identification of current research trends and illuminates potential research avenues, serving as a valuable compass for scholars to gauge the domain's current landscape and discern existing research gaps (Feng et al. 2017). In complement to bibliometric analysis of the literature in various business research fields, we utilized text mining to capture state-of-the-art GenAI applications in industry, serving as a frontier for academic inquiry. This approach sourced real-time data from industry reports, technical blogs, and influential social media, filling the gap between scholarly literature and emerging industry practices. Hence, our study offers a timely, holistic view, bridging academic research and real-world applications of GenAI in business and management.

### Search Strategy Design

For our bibliometric analysis, we selected the Web of Science and Scopus databases. These databases were chosen for their comprehensive coverage of scholarly articles, rigorous peer-review processes, and their widespread recognition as premier sources for academic research (Feng et al., 2017).

To ascertain the most relevant articles, our initial search strategy employed the combination of the terms "GenAI" and "business & management." This strategy was informed by an examination of existing literature reviews and alignment with the framework's guidance (Fraiwan & Khasawneh, 2023). To ensure a more exhaustive coverage, we further expanded and refined our search. The term "GenAI" was broadened to include variations such as "Generative AI" and "Generative Artificial Intelligence." Similarly, "business & management" was extended to encompass related domains like "marketing," "strategy management," and "organizational behaviour," among others. This iterative process, involving multiple searches, allowed for continuous optimization of our search query. A detailed list of the final queries employed can be found in APPENDIX. The culmination of this search strategy yielded a total of 304 articles from both databases for further analysis.



Figure 1: Procedures of the literature search and selection

### Search Result Assessment

For a meticulous and comprehensive analysis, our search spanned two leading databases: Scopus, yielding 172 documents, and Web of Science (WOS), with 132 documents. To ensure the timeliness and relevance of the articles, we filtered the results to include only those published between 2021 and 2024. Prioritizing the global lingua franca of academic research, we limited our selection to articles written in English, further refining our dataset to 156 documents from Scopus and 121 from WOS. Recognizing the nascent nature of research on GenAI in business and management, and the fact that a significant chunk of the latest insights stem from conference proceedings, we decided to include both journal articles and conference papers in our dataset. Collating the results from both databases, we had a cumulative count of 221 documents. To streamline this dataset further, duplications were removed, reducing the list to 188 articles. A thorough manual review was then initiated to ensure that each article was not only relevant but also offered substantial insights into the applications of GenAI in business and management. This rigorous selection process culminated in a refined list of 121 pivotal articles for our analysis. The detailed progression of

our literature search and selection is elucidated in Figure 1. Figure 1 illustrates the number of articles published each year to identify trends over time, categorizing articles based on their primary focus within business and management (e.g., marketing, strategy, organizational behavior). This step provided a preliminary understanding of the research landscape and highlighted the most influential contributors and publications in the domain.

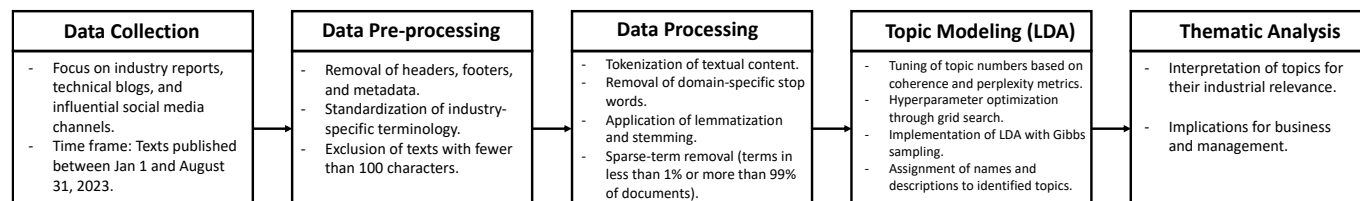

Figure 2: Procedures of text mining

### Text Mining

We tailored a text mining framework to focus on tweets, industry reports, technical blogs, and influential social media channels. The data collection phase captured texts published between Jan 1 and August 31, 2023, to ensure timeliness and relevance. During the pre-processing stage, headers, footers, and metadata were removed, and industry-specific terminology was standardized. Texts with fewer than 100 characters were excluded to maintain content substance. The subsequent data processing stage involved tokenization, domain-specific stop-word removal, lemmatization, and stemming. Sparse terms—those appearing in less than 1% or more than 99% of the documents—were also eliminated. For topic modeling, Latent Dirichlet Allocation (LDA) was employed with tuned hyperparameters and Gibbs sampling (Taecharunroj, 2023). The resulting topics were then named, described, and subjected to thematic analysis to interpret their industrial relevance and implications for business and management. Furthermore, we conducted exploratory analysis and visualization by generating summary statistics and a word cloud to visually represent the frequency of words in the descriptions. Finally, we provided insights based on the word cloud and other analyses, explaining the significance and implications of the findings. This comprehensive approach provides a real-time snapshot of the state-of-the-art applications of GenAI in the targeted domain.

### In-depth Bibliometric and Thematic Analysis

The final step involved a comprehensive bibliometric analysis, utilizing tools to map out citation networks and identify key clusters of research. This helped in discerning the most influential works and tracing the evolution of research themes over time. Concurrently, a thematic content analysis was performed. Articles were grouped based on recurring themes, which allowed for the identification of major research streams, emergent trends, and potential gaps in the literature. The combination of both bibliometric and thematic analyses ensured a holistic understanding of the state of research on GenAI in the realm of business and management.

## RESULT & DISCUSSION

### Bibliometrics Findings

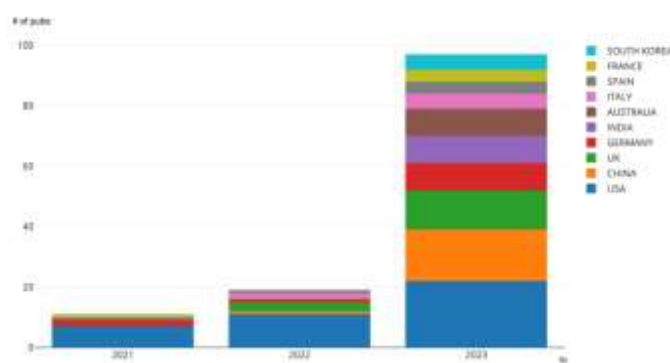

Figure 3: Number of Publications per Year (Clustered by Countries)

### Publication overview and trends

Over the selected years, there was a consistent annual increase in the number of publications related to GenAI in business and management. Notably, the year 2023 witnessed a significant surge in publications, indicating heightened interest and contributions in that period (Figure 2).



	Dynamics of Consumer Interaction	4
	Marketing Analytics	4
	Content Creation	5
	Fusion of Digital Marketing	3
	Other	22
<b>Other Buiness &amp; Management</b>		50

We discerned overarching themes from the titles, keywords, and abstracts of the articles. The analysis unveils four profound potentials of Generative AI, i.e. 1) creating new interfaces for service providers and personalized experience; 2) creating new content to augment human creativity; 3) improving efficiency and productivity, and 4) enabling more new applications, business models and use in the practical business applications (Table 1).

### Text Mining Findings



Figure 6: The Generative AI Application Landscape

Source: Sequoia Capital's generative AI Landscape

### Industry overview and trends

GenAI, with its diverse applications, is prominently featured across a myriad of domains, underscoring its adaptability and wide-ranging utility. Our text mining analysis reveals that text and video applications are at the forefront of this technological surge, with each domain boasting representation from 29 companies (Figure 6). This trend underscores the burgeoning emphasis the industry places on content creation, manipulation, and analysis. Not far behind, audio and image applications are emerging as significant players with each domain being represented by 26 companies, highlighting the escalating importance of multimedia in the GenAI arena. Conversely, the gaming sector appears to be a more specialized niche within the GenAI industry, with a mere 5 companies staking a claim, suggesting potential avenues for future exploration and development.

### Geographical and institutional distribution

In an analysis of GenAI applications across industries, distinct geographical and institutional patterns emerge. Geographically, San Francisco, California, stands out as a predominant hub, hosting a significant number of GenAI applications. This is followed by other prominent cities like New York, London, Tel Aviv, and Berlin, emphasizing the global dispersion of GenAI innovations. Institutionally, Y Combinator emerges as the foremost supporter of GenAI ventures, funding a substantial number

of applications. Other notable institutions, such as Techstars and Tiger Global Management, also play pivotal roles in fostering the growth of GenAI applications.

### Thematic content analysis

Table 2: Text Mining Analysis

Topics	Representative Words	Shortened Detailed Description	Relevant Industry Involved	Relevant Business Field
Virtual Assistants	virtual, assistants, automate, customer, support, handling, inquiries, completing, transactions	Automate customer support and inquiries.	IT, E-commerce, Retail, Hospitality	IS (e.g. HCI), Marketing (e.g. CRM), Management (e.g. Service Operations, Organization Behavior)
Recommendation Systems	recommendation, systems, analyze, user, data, offer, personalized, recommendations, products, services	Personalize product and service recommendations.	E-commerce, Media, Entertainment	IS, Marketing
Data Augmentation	data, augmentation, generate, synthetic, data, augment, existing, datasets, improving, machine, learning, models	Enhance ML datasets with synthetic data.	IT, Healthcare, Automotive, Research	IS, Marketing, Management
Fraud Detection	fraud, detection, analyze, data, patterns, identify, flag, suspicious, activities, mitigating, financial, risk	Identify suspicious activities, mitigate risk.	Banking, E-commerce, Insurance	IS, Finance, Auditing
Financial Forecasting	financial, forecasting, ai, predictive, analysis, market, trends, aiding, strategic, decision, making	Aid in market trend prediction and decision-making.	Banking, Stock Market, Investment Firms	Finance, IS
Content Generation	content, generation, automate, creation, various, content, types, articles, blog, posts, social, media	Automate creation of articles, social media.	Media, Advertising, E-commerce	IS, Marketing
Creative Design	creative, design, assist, generating, graphic, designs, logos, product, packaging	Assist in graphic design and branding.	Advertising, Media, E-commerce, Retail	Marketing, IS
Image/Video Synthesis	image, video, synthesis, create, realistic, images, videos, advertising, entertainment, purposes	Create visuals for advertising and entertainment.	Entertainment, Advertising, E-commerce	Marketing, IS
Virtual Try-On	virtual, try, augmented, reality, enable, virtual, trials, fashion, beauty, products, e, commerce	Enable virtual trials via augmented reality.	E-commerce, Fashion, Beauty	Marketing, IS
Supply Chain Optimization	supply, chain, optimization, analyze, optimize, production, inventory, logistics, improve, efficiency, reduce, costs	Improve production and logistics efficiency.	Manufacturing, E-commerce, Retail, Logistics	IS, Operations Management and Supply Chain,
Language Translation	language, translation, facilitate, cross, language, communication, through, translation, natural, language, processing	Facilitate global communication via NLP.	E-commerce, Media, International Business	Marketing
Game Development	game, development, generate, game, assets, non, player, characters, enhanced, gaming, experiences	Generate assets and characters for games.	Entertainment, Gaming Industry	Marketing, IS
Drug Development	drug, development, accelerate, discovery, development, process, pharmaceuticals	Accelerate pharmaceutical research and discovery.	Healthcare, Pharmaceuticals, Biotechnology	Marketing, IS, Economics

Music Composition	music, composition, generate, original, musical, compositions, background, music, various, applications	Create original compositions and background music.	Entertainment, Advertising, Media	Marketing, Law
Healthcare Diagnosis	healthcare, diagnosis, assist, analyzing, medical, images, x, rays, mris, accurate, disease, diagnosis	Assist in medical imaging for disease diagnosis.	Healthcare, Medical Devices, Hospitals	IS, Marketing, Management

Utilizing Latent Dirichlet Allocation (LDA) and extracting the key points from our text mining analysis results, we present an overview of GenAI applications across various industries and their corresponding business fields (Table 2). Key topics include Virtual Assistants, Recommendation Systems, Data Augmentation, and Fraud Detection, among others. These applications span a broad range of sectors, from IT and E-commerce to Healthcare and Entertainment. Each topic is accompanied by representative words and a brief description of its function. In the following sections, we will elaborate on the findings of the roles of GenAI in various research contexts and industrial applications in each of the three research fields, i.e. information systems, marketing, and management.

## Synthesized Analysis by Topics

### Information Systems

#### *Academia Findings (Literature Insights):*

Information systems, at its core, revolve around the effective collection, organization, and dissemination of information to facilitate decision-making and streamline operations. In recent years, the infusion of GenAI into various information systems has catalyzed a transformative shift, offering both unprecedented opportunities and intricate challenges. Within the theme of information systems, our analysis unveils three pertinent examples in the application of GenAI: Hospital Information Systems, Tourism Information Systems, and General Management Information Systems.

(1) *Hospital Information Systems (HIS)*: The integration of AI, and particularly models like ChatGPT, into healthcare communication, presents a paradigm shift. A recent paper delves into the potential of ChatGPT to enhance communication within healthcare settings, catering to both patients and healthcare professionals. By providing real-time, accurate, and personalized information, such AI models can address the prevailing challenges of healthcare communication (Cheng et al., 2023; Praveen & Vajrobol, 2023; Santandreu-Calonge et al., 2023). However, a salient point made by the authors is the need for prudence. While AI's potential is undeniable, it cannot and should not eclipse the role of human healthcare providers. Researchers posit that AI's true potential in healthcare might be realized when used in tandem with other AI tools, offering more nuanced and tailored responses (Santandreu-Calonge et al., 2023). For practitioners, the underpinning implication is clear: while ChatGPT and similar tools can augment patient care and communication, an over-reliance or misplaced trust could be counterproductive.

(2) *Tourism Information Systems (TIS)*: The hospitality and tourism sector, characterized by its dynamic and customer-centric nature, stands to gain immensely from GenAI. Research in this area underscores the transformative potential of ChatGPT within this industry (Dogru et al., 2023; Dwivedi et al., 2023; Law et al., 2023; Tuomi, 2023). However, as with any technological integration, challenges loom large, be it from the standpoint of businesses, customers, or regulatory bodies. This study serves as a beacon for those in the hospitality sector keen on integrating tools like ChatGPT. While the potential benefits are manifold, ranging from enhanced customer service to more streamlined operations, the pitfalls, particularly during the service delivery phase, warrant attention. For businesses, the key takeaway is twofold: the integration of GenAI can be a game-changer, but it necessitates a holistic understanding and upskilling of personnel to harness its full potential.

(3) *General Management Information Systems*: Management, in its multifaceted roles from strategy formulation to functional oversight, is witnessing a silent revolution with the advent of GenAI. Korzynski et al. (2023) extrapolates the implications of tools like ChatGPT across various managerial layers. Whether it's strategic decision-making, knowledge management, or even more granular administrative tasks, GenAI looms as a pivotal influencer. This paper not only expands the discourse on GenAI's role in management but also accentuates the need for empirical studies to discern its tangible impacts. For those at the helm of organizations, the insights from this study are invaluable. GenAI, in all its promises, beckons a recalibration of traditional management practices, offering a blend of efficiency and innovation.

(4) *Organizational Information Systems Performance*: The empirical study by Chu (2023) on the influence of ChatGPT on organizational performance offers a quantitative lens to gauge the technology's efficacy. Drawing from the DeLone and McLean's Information Systems Success model, the research highlights the quality dimensions of ChatGPT that drive user satisfaction and, by extension, organizational performance. Service quality emerges as a key driver, underscoring the importance of effective AI-human interactions. For businesses, this study offers a blueprint for leveraging ChatGPT to drive both user satisfaction and organizational growth. It also carved a niche in the academic landscape by quantitatively exploring the interplay between user satisfaction, ChatGPT, and performance.

#### *Industry Findings (Text Mining Insights):*



In the evolving landscape of information systems, GenAI's integration with predictive analytics, particularly in sectors like healthcare and social networks, presents novel research prospects. This amalgamation underscores GenAI's transformative potential across various information system domains. For instance, in the realm of virtual assistants, GenAI is streamlining the automation of customer support by adeptly handling inquiries and facilitating transactions. Simultaneously, recommendation systems, enhanced by GenAI, are now more adept at analyzing user data to furnish tailored product and service suggestions. Furthermore, GenAI's prowess in data augmentation is evident as it can ingeniously produce synthetic data, thereby enriching existing datasets and bolstering machine learning results. In the domain of fraud detection, the analytical capabilities of GenAI come to the fore, discerning data patterns to pinpoint and counteract suspicious activities, which plays a pivotal role in financial risk mitigation. Moreover, the fusion of AI and predictive analysis under the banner of GenAI is reshaping financial forecasting, offering invaluable insights into market trends and aiding in judicious decision-making. Yet, as the adoption of GenAI tools gains momentum, the information systems community is confronted with challenges, namely addressing inherent biases, assuring transparency, and grappling with the ethical implications from a decidedly human-centric standpoint. Consequently, there's a burgeoning call within the academic community for a comprehensive longitudinal study to gauge GenAI's sustained impact on information systems, aiming to elucidate both its merits and potential challenges.

### **Management, Operation & Supply Chain**

#### *Academia Findings (Literature Insights):*

The domain of Management, Operation, and Supply Chain sits at the crossroads of efficiency, strategy, and optimal resource allocation. With the advent of GenAI, especially tools like ChatGPT, there's an unfolding narrative that delves deep into the potential shifts, advantages, and complexities that such technologies bring. Diving into this theme, our discussion spans two primary topics: Operations and Supply Chain Management, and Organizational Behavior.

#### *(1) Operations and Supply Chain Management:*

Emerging technologies like GenAI and ChatGPT are rapidly reshaping the contours of operations and supply chain management. A recent exploration by Fosso Wamba et al. (2023) in this realm sourced insights from practitioners in the UK and USA to discern the tangible benefits, prevailing challenges, and emergent trends that these technologies promise. The findings underscore a paramount advantage: efficiency. Both those who have embraced and those who are yet to adopt GenAI/ChatGPT in operations and supply chain management tout increased efficiency as a critical benefit. Yet, the path isn't devoid of hurdles, with concerns around security, inherent risks, and ethical implications taking center stage. Other study (Chowdhury M. et al., 2023; Frederico G.F., 2023) also reveal that GenAI/ChatGPT can catalyze a shift towards a learning culture centered on efficiency, fostering lifelong learning and knowledge sharing. For businesses, the message is clear: while GenAI can redefine collaboration and communication within the supply chain, enhancing both efficiency and flexibility, it's imperative to be cognizant of and mitigate the associated risks.

#### *(2) Organizational Behavior:*

The impact of AI on organizational behavior is profound. A systematic review (Bankins et al., 2023) pinpoints key themes that emerge with AI integration: the dynamics of human-AI collaboration, shifting perceptions of algorithmic capabilities, evolving worker attitudes towards AI, and the broader labor implications. For businesses, the study offers critical takeaways: the importance of transparency in AI integration, the need for open communication channels, and the imperative of aligning AI systems with overarching organizational objectives.

#### *Industry Findings (Text Mining Insights):*

In the ever-evolving domain of management, operations, and supply chain, GenAI is emerging as a vital research vector, offering profound insights and transformative possibilities. A pivotal area of interest is the potential metamorphosis of managerial practices propelled by the harmony between AI and human interaction. There's an evident inclination towards harnessing GenAI for risk management, emphasizing the potency of AI-human collaboration in charting out robust risk mitigation strategies. This is further bolstered by the significant strides made in supply chain optimization. Through GenAI, there's an enhanced capability to meticulously analyze and optimize facets of production, inventory, and logistics, driving both operational efficiency and cost reduction.

Moreover, a contemporary focus rests on integrating AI to amplify supply chain transparency. This not only facilitates ethical sourcing, ensuring that supply chains are devoid of malpractices but also accentuates the importance of aligning technology seamlessly with human-centric needs and values. While the aforementioned delve deep into operations and supply chain, it's noteworthy that GenAI's influence transcends these realms. For instance, in the broader spectrum of business management, GenAI is facilitating cross-language communication through advanced natural language processing, enabling organizations to communicate and operate globally with ease.

### **Marketing**

#### *Academia Findings (Literature Insights):*

GenAI's profound influence in the marketing domain underscores the trend towards interdisciplinary collaboration, particularly with social sciences like sociology and psychology. As articulated by Davenport et al.(2020), the fusion of AI with marketing fosters a holistic understanding of consumer behavior, refining marketing strategies and contributing richly to the discipline. Within this theme, two sub-categories emerge: Marketing, i.e. Internal Marketing Transformation, emphasizes how businesses

employ GenAI to transform their internal marketing strategies, workflows, and decision-making processes. Customer Experience focuses on applications that augment the consumer experience, leveraging GenAI to provide more tailored services and products. These advancements not only redefine the interactive touchpoints between businesses and consumers but also underscore the nuances of personalization, automation, and engagement.

(1) *Marketing Analytics*: Haluza and Jungwirth (2023) spotlighted the potential of GenAI models like GPT-3 in offering lucid insights into intricate societal megatrends. These AI models are adept at generating innovative solutions to global challenges. However, alongside their capabilities, there's an impending need for a rigorous ethical discourse, especially when these models are deployed for scientific research paper generation.

(2) *Content Creation*: A pivotal aspect of modern marketing is content creation. Taecharungroj (2023) emphasizes the transformative potential of ChatGPT in this realm. By harnessing the capabilities of ChatGPT, marketers can craft content that not only engages but deeply resonates with their target demographics. The implication is a more profound engagement, leading to potentially higher conversion rates.

(3) *Fusion of Digital Marketing*: Delving into the confluence of ChatGPT and digital marketing, investigates the multifaceted impact of this technology on customer experience. The findings underscore a generally positive influence of ChatGPT on customer experience. However, this effect isn't universal; it is modulated by factors like business type, technological familiarity, demographic variables like age and gender, and educational background (Fosso Wamba S. et al., 2023). Such findings have significant ramifications for businesses. While the incorporation of ChatGPT in digital marketing endeavors is promising, there's an imperative to understand and cater to the diverse profiles of their consumers. Tailoring the ChatGPT experience based on these moderating factors can be the linchpin in optimizing customer experience in the digital realm.

(4) *Personalized Customer Experience*: The allure of personalized shopping experiences, bolstered by tools like ChatGPT, is undeniable. Konya-Baumbach et al., (2023) delve deep into this domain, elucidating the profound impact of anthropomorphic chatbots on various facets of the shopping experience. From engendering trust and intent to purchase to fostering word-of-mouth recommendations, these chatbots have showcased significant efficacy. Interestingly, their effectiveness is not monolithic but varies based on the shopping context. Hedonic scenarios, for instance, witness a more pronounced positive effect. For businesses in the retail sector, the insights from this study are invaluable. While anthropomorphic chatbots can undoubtedly enhance the shopping experience, understanding the context and tailoring interactions accordingly can amplify their impact manifold.

(5) *Chatbots*: Exploring the domain of AI-powered chatbots, Adam et al. (2021) underscores their influence on user compliance within customer service contexts. Building on foundational research surrounding Computer-Assisted Systems (CAS) and their embodied variants, the study posits that even disembodied entities can foster a sense of social presence and induce user compliance via verbal cues. A salient insight from this research is the pivotal role of anthropomorphic design cues, such as identity and empathy, in enhancing compliance with chatbot-driven requests. Moreover, the study offers a contrarian viewpoint, suggesting that masquerading chatbots as humans might neither be necessary nor desirable. For businesses contemplating the deployment of AI-based chatbots in customer self-service, the key takeaway is twofold: transparency in revealing the non-human nature of the interlocutor and the strategic infusion of anthropomorphism to enhance human likeness.

(6) *Dynamics of Consumer Interaction*: In a comprehensive exploration, Paul et al. (2023) dissect the intricate relationship between AI-driven tools and consumer behavior, with a focus on the broader implications for marketing strategies. Their research underscores the multifaceted benefits of integrating ChatGPT in marketing—ranging from enhanced consumer engagement, and incisive insights into consumer behavior, to personalization. However, it's equally imperative to acknowledge the attendant challenges. Issues of bias, potential misinformation, and overarching ethical considerations emerge as areas of concern. As businesses increasingly lean on AI tools, understanding these dynamics becomes crucial not just from an engagement perspective but also for maintaining ethical transparency and trustworthiness.

#### *Industry Findings (Text Mining Insights):*

In the modern marketing domain, GenAI emerges as a formidable force, offering expansive research horizons particularly in the customization of content tailored for distinct user demographics. One of the most profound applications is in content generation, where GenAI is automating the creation process, spanning from articles to social media content. This automation is further accentuated in the realm of creative design, as GenAI assists in churning out graphic designs, logos, and even intricate product packaging, elevating the branding experience. Beyond static content, the arena of image and video synthesis witnesses GenAI's capability to craft realistic visuals, serving both advertising and entertainment sectors. An exciting frontier is the incorporation of GenAI in 'virtual try-on' systems, leveraging augmented reality to provide users with immersive experiences as they virtually trial fashion and beauty products, a boon for e-commerce platforms.

However, the widespread deployment of GenAI in marketing brings forth intricate challenges. A significant apprehension lies in GenAI's influence on consumer trust, questioning the authenticity of AI-generated content. Hence, there is a pressing need to harmonize GenAI's capabilities with human decision-making and emotional engagement, ensuring that ethical considerations aren't overshadowed. It's pivotal to strike a balance between AI-driven analytics and human oversight, ensuring that the enhanced customer experience doesn't come at the cost of genuine human interaction. The increasingly human-like demeanor of AI chatbots, integral for user adherence, warrants meticulous research. Identifying the optimal degree of "human-likeness" can

redefine AI-user dynamics across sectors. Additionally, the cultural dimensions of AI reception, coupled with the ethical intricacies of hyper-personalization and the mandate to disclose AI's involvement, underscore areas ripe for exploration.

### **Summary**

By combining insights from both academia and industry, we aim to provide a comprehensive understanding of the research imperatives that can address the evolving challenges and opportunities in the deployment of Generative AI across business and management domains.

***In the field of Information Systems***, the intersection of Generative AI with existing AI systems such as predictive analytics offers a rich research avenue. As GenAI begins to reshape the contours of healthcare communication and social network information flow, an imperative arises to study its synergetic integration with tools like predictive analytics. Such research could unveil comprehensive solutions that amplify the benefits of each individual system. However, the current literature may not fully address how these theoretical ethical considerations manifest in tangible business outcomes. Concurrently, the ethical dimensions of GenAI in these sensitive sectors warrant rigorous academic scrutiny. A human-centered approach to GenAI's ethical considerations, biases, and transparency requirements is a pressing academic priority. Furthermore, there's a distinct gap in studying the real-world implementation of AI-human collaboration and its challenges. Moreover, a longitudinal perspective, assessing the long-term efficacy and efficiency of GenAI in information systems, would provide invaluable insights into its sustained impact.

***In the field of Management, Operation & Supply Chain***, the transformative potential of GenAI in operations and supply chain management presents a plethora of research opportunities. Prioritizing research on risk mitigation strategies, particularly those that combine AI's capabilities with human expertise, is paramount. Investigating the equilibrium of human-manager collaboration in AI-augmented settings could redefine managerial practices. The nuances and complexities introduced by GenAI have led to a notable gap: the study of practical consumer engagement through AI in real-world industry settings. In the management echelon, the dynamics of human-manager collaboration with AI tools are ripe for exploration. Unraveling this balance, which ensures decision-making efficiency while retaining the indispensable human touch, could redefine managerial paradigms. Furthermore, as GenAI enhances supply chain transparency, scholarly inquiry should extend to traceability and ethical sourcing, always considering how technology can best serve human values and needs.

***In the field of Marketing***, GenAI's foray into marketing introduces a myriad of research possibilities. A prime area of focus is the AI's capability to craft hyper-personalized marketing content tailored to individual user personas. Yet, the degree of perceived "human-likeness" and how this perception varies across sectors and cultural contexts remains underexplored. As GenAI systems become more entrenched in marketing, understanding their nuanced impact on consumer trust, especially concerning perceived authenticity, emerges as a research imperative. Moreover, given the expanding role of GenAI in digital marketing, content creation, and marketing analytics, future research could beneficially explore how these technologies can be designed to respect and enhance human decision-making and emotional engagement. With the global reach of businesses, investigating the cultural dynamics influencing AI reception becomes essential. This would involve understanding how GenAI can be optimally leveraged in these digital landscapes to provide genuinely useful insights and solutions, without compromising ethical norms or human-centric values. Special emphasis should be given to the role of human oversight in interpreting and acting upon the insights generated by AI in marketing analytics. Moreover, the realm of customer experience, enriched by GenAI, beckons a multifaceted and human-centric research approach. The anthropomorphic attributes of AI chatbots, given their significance in user compliance, present a compelling avenue for investigation. Understanding the optimal level of human-likeness across different sectors could redefine AI-customer interactions. Additionally, as personalization pushes boundaries, the ethical dimensions of extreme customization, coupled with the obligation to clearly signal AI's involvement, require deeper exploration.

### **CONCLUSION**

The advent of Generative AI (GenAI) heralds a new era in the business domain, bringing forth transformative potential across a spectrum of sectors ranging from information systems, to supply chain operations and marketing. Our comprehensive study, grounded in bibliometric analysis, critically appraises academic discourse surrounding GenAI in business and management. Concurrently, utilizing text mining techniques, we delve into cutting-edge industrial applications of GenAI. By synthesizing these twin perspectives, we aim to identify gaps between practical applications and scholarly investigations in the field, revealed salient power of GenAI.

First, creating new interfaces and personalizing experiences: AI has the capability to create new interfaces for service providers, transforming the way users interact with businesses. For example, chatbots and virtual assistants powered by AI can offer personalized and conversational experiences, addressing user queries, providing recommendations, and guiding customers through various processes. These interfaces can be available 24/7, enhancing customer engagement and satisfaction. There is a notable shift towards employing GenAI for enhancing customer experience and streamlining operations. The role of anthropomorphic attributes in GenAI chatbots, for instance, has been underscored for its potential in augmenting user compliance and deepening engagement (Adam et al., 2021; Atlas, 2023; Konya-Baumbach et al., 2023). Second, generating new content and augmenting Human Creativity: GenAI algorithms can generate new and original content across various domains. They can create articles, stories, artwork, music, even movies based on given inputs or patterns. By augmenting human creativity, GenAI empowers content creators and artists to explore new possibilities, generate ideas, and produce high-quality content more efficiently. This collaboration between GenAI and human creativity can result in unique and captivating content experiences.

Third, improving efficiency and productivity: GenAI technologies, such as machine learning and automation, significantly improve efficiency and productivity in various business processes. GenAI-powered systems can improve themselves continuously to automate repetitive tasks, data analysis, and decision-making processes, allowing employees to focus on more complex and strategic activities. This leads to time savings, reduction in human errors, and increased overall productivity in industries ranging from manufacturing and logistics to customer service and data analysis. Specifically, the integration of GenAI in the supply chain and operations sectors underscores efficiency as a paramount benefit, albeit with a set of unique challenges including security concerns and ethical implications. Last but not least, enabling new applications and uses: The versatility of GenAI allows businesses to explore innovative solutions and uncover new opportunities for growth and development. GenAI opens doors to new applications and uses that were previously unimaginable, e.g., personalized marketing strategies. The infusion of GenAI in marketing demonstrates its potential to refine strategies by offering a deeper understanding of consumer behavior, opening avenues for hyper-personalized content creation and innovative solutions to global challenges.

This study contributes to the IS literature by leveraging a two-pronged approach: text mining to scrutinize existing business applications and a bibliometric review to assess the current academic investigations on GenAI. We identify new research opportunities by investigating the gap between real-world GenAI applications in business and management and the extant IS/Business research, thereby identifying novel research contexts and perspectives for future investigations.

Nevertheless, the study has certain limitations. Due to the nascent nature of the research area, there was a scarcity of literature available for scrutiny, potentially overlooking emergent themes or subtle insights. It's crucial to highlight that our data was primarily drawn from Scopus and Web of Science. In subsequent research, we plan to diversify our sources by integrating data from databases such as EBSCO and Google Scholar, aiming for a more expansive and holistic view. Yet, in light of these constraints, the knowledge gleaned from this investigation is of paramount importance. The necessity to comprehend the progression and present status of research on GenAI in the business sphere is undeniable. As global businesses attempt to adapt to an ever-changing technological frontier, understanding the transformative potential and hurdles presented by GenAI becomes vital in steering through this uncharted territory.

In conclusion, as GenAI tools like ChatGPT continue to push the boundaries of what's possible in the business sector, it becomes imperative for scholars and industry practitioners alike to maintain a rigorous engagement with these technological advancements. The harmonization of business strategies with advanced AI technologies not only amplifies existing paradigms but also delineates new trajectories for innovation. This study serves as a preliminary roadmap for navigating this complex, evolving landscape, highlighting areas that warrant immediate scholarly attention.

## REFERENCES

- Adam, M., Wessel, M., & Benlian, A. (2021). AI-based chatbots in customer service and their effects on user compliance. *Electronic Markets*, 31(2), 427–445. <https://doi.org/10.1007/s12525-020-00414-7>
- Atlas, S. (2023). *ChatGPT for Higher Education and Professional Development: A Guide to Conversational AI*.
- Bankins, S., Ocampo, A., Marrone, M., Restubog, S., & Woo, S. (2023). A multilevel review of artificial intelligence in organizations: Implications for organizational behavior research and practice. *JOURNAL OF ORGANIZATIONAL BEHAVIOR*. <https://doi.org/10.1002/job.2735>
- Cheng, K., Li, Z., He, Y., Guo, Q., Lu, Y., Gu, S., & Wu, H. (2023). Potential Use of Artificial Intelligence in Infectious Disease: Take ChatGPT as an Example. *ANNALS OF BIOMEDICAL ENGINEERING*. <https://doi.org/10.1007/s10439-023-03203-3>
- Chowdhury M., Rifat N., Latif S., Ahsan M., Rahman M.S., & Gomes R. (2023). ChatGPT: The Curious Case of Attack Vectors' Supply Chain Management Improvement. *IEEE International Conference on Electro Information Technology*. <https://doi.org/10.1109/eIT57321.2023.10187385>
- Chu, M.-N. (2023). Assessing the Benefits of ChatGPT for Business: An Empirical Study on Organizational Performance. *IEEE Access*, 11, 76427–76436. <https://doi.org/10.1109/ACCESS.2023.3297447>
- Davenport, T., Guha, A., Grewal, D., & Bressgott, T. (2020). How artificial intelligence will change the future of marketing. *Journal of the Academy of Marketing Science*, 48(1), 24–42. <https://doi.org/10.1007/s11747-019-00696-0>
- Deveau, R., Griffin, S. J., & Reis, S. (2023). *AI-powered marketing and sales reach new heights with generative AI*. McKinsey & Company.
- Dogru, T., Line, N., Mody, M., Hanks, L., Abbott, J., Acikgoz, F., Assaf, A., Bakir, S., Berbekova, A., Bilgihan, A., Dalton, A., Erkmen, E., Geronasso, M., Gomez, D., Graves, S., Iskender, A., Ivanov, S., Kizildag, M., Lee, M., ... Zhang, T. (2023). Generative Artificial Intelligence in the Hospitality and Tourism Industry: Developing a Framework for Future Research. *Journal of Hospitality & Tourism Research*. <https://doi.org/10.1177/10963480231188663>
- Dwivedi, Y. K., Pandey, N., Currie, W., & Micu, A. (2023). Leveraging ChatGPT and other generative artificial intelligence (AI)-based applications in the hospitality and tourism industry: Practices, challenges and research agenda. *International Journal of Contemporary Hospitality Management*. <https://doi.org/10.1108/IJCHM-05-2023-0686>
- Feng, Y., Zhu, Q., & Lai, K.-H. (2017). Corporate social responsibility for supply chain management: A literature review and bibliometric analysis. *Journal of Cleaner Production*, 158, 296–307. <https://doi.org/10.1016/j.jclepro.2017.05.018>

- Fosso Wamba S., Queiroz M.M., Chiappetta Jabbour C.J., & Shi C.V. (2023). Are both generative AI and ChatGPT game changers for 21st-Century operations and supply chain excellence? *International Journal of Production Economics*. <https://doi.org/10.1016/j.ijpe.2023.109015>
- Fraiwan, M., & Khasawneh, N. (2023). *A Review of ChatGPT Applications in Education, Marketing, Software Engineering, and Healthcare: Benefits, Drawbacks, and Research Directions*.
- Frederico G.F. (2023). ChatGPT in Supply Chains: Initial Evidence of Applications and Potential Research Agenda. *Logistics*. <https://doi.org/10.3390/logistics7020026>
- Groos, O. V., & Pritchard, A. (1969). DOCUMENTATION NOTES. *Journal of Documentation*, 25(4), 344–349. <https://doi.org/10.1108/eb026482>
- Haluza, D., & Jungwirth, D. (2023). Artificial Intelligence and Ten Societal Megatrends: An Exploratory Study Using GPT-3. *Systems*, 11(3), 120. <https://doi.org/10.3390/systems11030120>
- Konya-Baumbach, E., Biller, M., & Von Janda, S. (2023). Someone out there? A study on the social presence of anthropomorphized chatbots. *Computers in Human Behavior*, 139, 107513. <https://doi.org/10.1016/j.chb.2022.107513>
- Korzynski, P., Mazurek, G., Altmann, A., Ejdys, J., Kazlauskaitė, R., Paliszkievicz, J., Wach, K., & Ziemba, E. (2023). Generative artificial intelligence as a new context for management theories: Analysis of ChatGPT. *Central European Management Journal*, 31(1), 3–13. <https://doi.org/10.1108/CEMJ-02-2023-0091>
- Law, R., Lin, K., Ye, H., & Fong, D. (2023). Artificial intelligence research in hospitality: A state-of-the-art review and future directions. *International Journal of Contemporary Hospitality Management*. <https://doi.org/10.1108/IJCHM-02-2023-0189>
- Paul, J., Ueno, A., & Dennis, C. (2023). ChatGPT and consumers: Benefits, Pitfalls and Future Research Agenda. *International Journal of Consumer Studies*, 47(4), 1213–1225. <https://doi.org/10.1111/ijcs.12928>
- Praveen, S., & Vajrobol, V. (2023). Can ChatGPT be Trusted for Consulting? Uncovering Doctor's Perceptions Using Deep Learning Techniques. *Annals of Biomedical Engineering*. <https://doi.org/10.1007/s10439-023-03245-7>
- Ratajczak, D., Kropp, M., Palumbo, S., de Bellefonds, N., Apotheker, J., & Paizanis, G. (2023). *How CMOs Are Succeeding with Generative AI*. Boston Consulting Group.
- Santandreu-Calonge, D., Medina-Aguerreberre, P., Hultberg, P., & Shah, M. (2023). Can ChatGPT improve communication in hospitals? *Profesional de la Informacion*. <https://doi.org/10.3145/epi.2023.mar.19>
- Taecharunroj, V. (2023). “What Can ChatGPT Do?” Analyzing Early Reactions to the Innovative AI Chatbot on Twitter. *Big Data and Cognitive Computing*, 7(1), 35. <https://doi.org/10.3390/bdcc7010035>
- Tuomi, A. (2023). AI-Generated Content, Creative Freelance Work and Hospitality and Tourism Marketing. *Information And Communication Technologies in Tourism 2023*, 323-328. [https://doi.org/10.1007/978-3-031-25752-0\\_35](https://doi.org/10.1007/978-3-031-25752-0_35)
- Van Dis, E. A. M., Bollen, J., Zuidema, W., Van Rooij, R., & Bockting, C. L. (2023). ChatGPT: Five priorities for research. *Nature*, 614(7947), 224–226. <https://doi.org/10.1038/d41586-023-00288-7>

#### APPENDIX: Query for Literature Search

( "Generative AI" OR "Generative Artificial Intelligence" OR "ChatGPT" OR "OpenAI" ) AND ( "Marketing" OR "Consumer" OR "Advertising" OR "Strategic management" OR "Organizational behavior" OR "Operations management" OR "Information systems" OR "Business" OR "Digital transformation" OR "Human resources" OR "Employee engagement" OR "Recruitment" OR "Talent management" OR "Finance" OR "Risk management" OR "Investments" OR "Supply chain" OR "Logistics" OR "Inventory management" OR "Entrepreneurship" )

## Delivering Smart Warehousing in Australia

S. Marino<sup>1,\*</sup>

\*Corresponding author

<sup>1</sup> Sam Marino, James Cook University, Cairns, Australia, [sam.marino@my.jcu.edu.au](mailto:sam.marino@my.jcu.edu.au)

### ABSTRACT

Smart warehousing continues to advance - particularly for larger storage supply-demand chain facilities. Such embedded digital, real-time AI engagement storage solutions often involve intelligent autonomous place, track, pack resource orchestration solutions targeting towards direct multi-consumer and marketplace rapid distributions, and into the future further linking towards retailing. This literature researched paper frames a research agenda to determine the relative smart warehousing pathway effects of supply side input competencies and of demand side actioned interactive capabilities in determining the sustainability of intelligent, lower-cost warehousing into the immediate future.

*Keywords:* Artificial intelligence (AI), Digital technologies, Warehouse management system, Artificial intelligence, Robotics, Machine learning, Autonomous smart warehousing, Internet of everything, Communications connectivity, Software solutions.

### INTRODUCTION

Over-time warehousing has developed from community storerooms to multimillion-dollar facilities. However, its purpose remains the same. Warehousing remains a place to temporarily store goods within the supply-demand chain network, with all processes effectively connected to maintain a smooth flow of goods (Kumar et al. 2021).

The concept of smart warehousing emerged from Industry 4.0 (the fourth industrial revolution), a German government hi-tech strategy showcased at the Hannover fair of 2011 (Kumar et al. 2021). Industry 4.0 refers to how automation, data, and computers interface and process desired information. The blending of this interface between the physical and the digital domain – including: AI, IoT, and automation, now impacts on societies and their everyday lives (Kumar et al. 2021).

In 2018 around 90% of warehousing worldwide was either manual, or engaged only low-levels of automation across the specific storage's operations. Firms utilizing warehousing are increasingly deferring towards incorporating advanced technologies, and automation, into their business plans. Over-time this enhances ongoing costs, makes better use of funds and of infrastructures, and builds IT (Information Technology) knowledge (Pontius, 2018). For example a consequence of the increasing demand for e-commerce (along with processing cost savings), the demand for still smarter warehousing is emerging. Smart warehousing links process stages in real-time. It can handle rapid multi-item processing, and depending on scale can deliver up to millions of items (or products) either daily or weekly. Consequently, as their use rises smart warehouses must continually upgraded their digital systems (Immerman, 2019). Accordingly, mobile, autonomous, compact, and/or collaborative systems are increasingly being applied into the systems within these smart warehouses (called Warehousing 4.0) (Mahmut, 2022).

Smart warehousing is reportedly the most effective and efficient way of raising the firm's ROI (Return on investment) by improving precision and performance and reducing manual labour costs (Kumar et al. 2021). The global supply chain's rapid growth, improvements in automation, communication technologies (ICT), and Industry 4.0, warehousing along with its embedded digital systems, have brought integration and real-time changes into warehousing practices and processes.

Warehousing is also moving from traditional (supply-store-ship) warehousing towards a digitally-connected, automated and integrated warehouse management system. Warehousing remain under considerable stress, and scalability. This is partly due to increasing demand for items. When expanding their warehousing requirements, industry actors and their firms recognise it is better to adapt to changing competitive business environments, by enlisting smart digital and integrated warehouse management systems (Kumar et al, 2021).

### LITERATURE REVIEW

#### Existing State of Play for Warehouse Space in Australia

The current vacant warehouse lease space availability in Australia is low, but demand remains record-high. As a result, the market is led by pre-commitments and speculative lease deals, with 2023 leasing take-up approximating 3.4M m<sup>2</sup> (Henderson et al. 2023).

Across 2022 modern, efficient warehouse lease space in Australia was lacking, and fewer assets were entering the marketplace. In addition, supply was at historically low levels as post-Covid-related new project developments and project completions became available. As a result, occupier warehouse demand was buoyant, and in 3Q 2022, gross take-up space was 988,410 m<sup>2</sup>. In contrast, 4Q 2022 gross take-up space fell to 684,160 m<sup>2</sup>.

Long-term average warehouse take-up space of 692,330 m<sup>2</sup> suggests macroeconomic drivers in Australia may lower occupier demand. Less available take-up space in Melbourne (27%) and Brisbane (47%) is particularly restricting take-up space levels within these two capital cities (Ballantyne & McFarlane, 2022).

E-commerce growth is another driver of warehousing floor space in Australia. As E-commerce increases, firms increase their stock holdings and seek further warehouse-related efficiencies. As a result, over the past ten years, the average floor space has increased from 12,000 m<sup>2</sup> to 25,000 m<sup>2</sup> today, and within Melbourne, the average floor space today is 45,000 m<sup>2</sup>.

There has been a 29% increased demand for take-up spaces above 30,000 m<sup>2</sup>. This exposes a trend where smaller businesses slow in warehouse take-up, but larger Australian companies, or occupiers, are moving forward, incorporating long-term logistics and business strategies (Henderson et al. 2023).

Australian retailers are currently planning and constructing smart, automated warehousing and fulfilment centres. Major Australian retail and logistic players investing millions of dollars in their supply chains and smart warehousing include Amazon, Coles, Woolworths, Australia Post, Booktopia, and online specialists Temple & Webster and Kogan. (DHL Logistic of Things, Insites, 2023).

Across 2024 and 2025, demand in Australia is likely to remain elevated as the nation's population and general consumption grow. At the same time, a pick-up in development-ready land availability, particularly in select capital cities, is likely to support other pre-commitment and speculative lease take-up space activities (Henderson et al. 2023).

Considering competitiveness, Australian firms or occupiers with less-efficient supply chains, are likely to continue migrating toward newer facilities, and to employ automation, or even migrate toward autonomous warehouse processing. Across 2023 such shifts are increasing the demand for take-up space and driving further pre-commitments regarding take-up space. Thus, Australian smarter warehousing is a likely driver for take-up warehouse lease space in the future.

### **Smart Warehousing**

The development of robotics, autonomous systems, edge technologies, and other collective intelligence interfacing with smart warehouse management systems likely offers near-real-time control and movement of goods in and out of the warehouse in logistically smart, fast, and efficient ways.

In addition, the information flow across the central (AI) platform offers machine learning and virtual reality (twinning learning). This likely assists the workforce in fault finding and in improving overall storage to marketplace servicing (Severns, 2022). As part of the automation process, robotics, advanced AI, cameras, and sensors can add communication channels between each automated machine or device, and the relevant members of the workforce. This likely assists in providing optimal location and status positioning, which can be then tracked directly through an integrated online control portal.

Using software to replace manual tasks minimises human assistance, and minimizes labour-intensive duties – especially those requiring repetitive physical activity, and/or manual data analysis (Jenkins, 2020). Zunic et al (2018) present a warehouse management system as a key directional component that simplifies, optimizes and drives efficiencies across item storage and item logistical transmission complexities. Warehouse management systems typically include digital automated, real-time: stock item planning, tracking, placement, picking, transfer, and logistical transport aspects of warehousing. Integrated warehouse management systems can make: anomalies (or risks) easier to detect, process improvements easier to find and fix, and deliver a more efficient entire digitally-driven interconnected and integrated digital management system.

Zhang et al. (2021) show Alibaba's smart warehousing solutions as an integrated 'resource orchestration' delivering value from collectively managed AI technologies, workforce personal, and input-to-output processes. They find when relevant key AI resources including: data, AI/ML algorithms, and robotics, are orchestrated to include coordinated, leveraged, and deployed solutions that operate in conjunction with other in-situ resources (including facilities, information systems, and workforce ingenuity), then still stronger AI capabilities can be generated.

Further smart warehousing advantages can be achieved where the AI systems can real-time project/forecast and learn – particularly by interacting efficiently with the workforce and its ingenuity, plus space, position, distance digital optimizations, and also with other productivity drivers (including error reduction and communicative connectivities. Thus smart warehousing requires a new skills-set for both the firm, and its workforce.

### **Smart Warehousing - Future Enablers**

Into the future smart warehousing will likely involve a suite of critical enablers, including continual growth in e/m-commerce, demands for instantaneous high-quality data, further strategic advantages, greater operational agility, less external threats, greater risk mitigations, more warehouse complexities, and new customer instantaneous demands (Ballantyne & McFarlane, 2022).



Consumer online transactions, or e/m-commerce solutions, are likely to require faster logistical interpretations and solution, and expanded consumer demands for specific information. This ideally helps rectify and/or reduce supply chain delays. In addition, such solutions may enlist smart digital network connectivities complete with new capabilities systems that together may simplify operations, reduce the needed workforce, and help overcome specific new-skills requirements.

Thus, the smart warehouse creates an environment of ongoing, accelerated, innovations. These then mesh with the latest relevant creative technologies, and together can support autonomous or advanced intelligent machine sensing operational systems - capable of improving and aligning smart warehouse productivity and associated logistics towards better meeting marketplace and consumer expectations (Burston et al. 2023).

Today instant connectivity systems require real-time information, near-instant response time, accuracy, and precision. This also applies to smart warehousing and its embedded logistics systems. In addition, the marketplace and consumers expect rapid deliveries. This stems from efficient and effective distribution centres, with enhanced digital warehouse management systems that link backward and drive responses throughout current supply chains. Today many warehouse management systems still remain susceptible to human input/output errors. However, merging warehouse systems with supply chain participant actors also requires the ability to process and interpret vast amounts of data.

To facilitate order picking and batch-handling efficiencies, goods-movement digital systems can now capture all warehousing aspects, from receiving to restocking to picking, packing, and shipping. Furthermore, all data and digital sensor inputs are network interfacing with management systems to provide rapid and reliable controls of processing (van Geest et al. 2021).

Hence today, automated smart warehouse systems are becoming a normative pathway towards improving overall storage responsiveness, agility, and flexibility, and to solve human error issues throughout the warehousing processes. These networks also bring advanced technologies complete with integrated Internet of Everything (IoE) solutions.

Into the future smart warehouse processing is likely to rely on increased order volumes, accurate order picking, digital dispatch logistics, ongoing workforce skills certainty, and collective intelligence (Celik & Sural, 2019). Warehouses adopting automation, smart robotics, and autonomous systems likely offer new pathways to transition from fixed equipment operations toward fast, fully-robotic random order processing, and possibly within workforce-free facilities (Burston et al. 2023).

### ***Smart Warehousing - Barriers***

Besides the initial smart warehousing development cost, various supply chain members often utilise digital, legacy, and non-standardized programming language systems. Such occurrences raise prices of interfacing and networking such member systems. In addition, the ongoing cost of maintenance and operating across such disparate member systems can be prohibitive. Hence the trend is towards migrating these disparate systems across standardised supply-demand chain systems.

The reliability of remote hardware, the limits of robotic technology, and robots' inability to identify, pick and pack everything, and especially irregularly-shaped items must improve to ensure reliable operations. In addition, technology continually changes as sensor, tracking, movement and engagement systems become more autonomous. However, this too remains a strategic and cost challenge (Tikwayo, L. N., & Mathaba, T. N. (2023). Applications of Industry 4.0 Technologies in Warehouse Management: A Systematic Literature Review. *Logistics*, 7(2), 24.).

A current human upskilling challenge remains the ability of the workforce to strategically deal with: system complexities, potential competing competitiveness positions, operational flows, and/or instantaneous decision requirements. Hence smart warehouse systems must also be human and workforce friendly, and incorporate resistance to human error.

There is a lack of knowledge in warehousing adoption of IoE strategies to robotics and AI/ML intelligences. Warehouse management systems are often limited to select parameters of set configurations, and to restrict big data adaptive requirements. Furthermore, not all systems can interact with different supply firm actors, as supplier programming languages often differ and so remain unstandardized and possibly incompatible to the programming languages used within the warehouse. This creates challenges and costly remedies to link different systems together.

Hence, building a smart warehouse is more expensive than traditional warehouses, and transitioning to a smart warehouse requires both effort and cost. In addition, there remains an inherent risk to data security, to privacy, and to confidentiality across all data collection systems (van Geest et al. 2021).

### ***Smart Warehousing - Study Motives***

A decade ago warehousing worldwide was primarily a manual storage and movement operation. However, competition and customer expectations of shorter, or same-day delivery times, necessitated the transformation manually-dominated workforce storage and movement operations, towards digital, hi-tech, autonomous, smart warehousing. The development and implementation of automation across storage systems, robotics rather than manual handling and picking, and intelligent information systems is assisting in facilitating this change to smart warehousing. (Chung, 2021)

The compounding effects of customer demand, along with greater informative expectations have caused warehousing operations to become more complex. The prime motivations identified are external threats, competitive advantages, increased data processing speed, warehouse complexity, operational speed, and customer demand. As a result, warehousing continues to become more complex, and customers have become more demanding (Ding, 2013). Hence, traditional warehousing is no longer suitable to satisfy the increasing demand of customer expectations. Instead, fast response time, accuracy, and real-time data information are necessary (Wang et al. 2015).

Retailers need efficient distribution centres supported by informative warehouse management systems that work in-hand with intelligent automation technologies that competitively manage a warehouse operation and the associated supply-demand chain. Retailers also continue to press for supply of goods at lower prices, in faster timeframes, and across shortest logistics supply-demand chains. This also engages the use of identification technologies –especially those linked to further enabling efficiencies and performance optimizations (Cheng et al., 2015). This requires the warehouse management system to intelligently seek-out and link efficiencies in management and operations - especially those that can reduce overall operating costs. However, because most warehouse management systems typically rely on human inputs rather than automated real-time data, there is room for inaccuracies, and these add to supply-demand chain complications (Zhou et al. 2017).

To solve such human error issues, warehouse and supply-demand chain actors likely need to merge and integrate their vast amounts of data capture. This data intelligence likely stimulates increasing needs for much more automated smart warehousing. Automated smart warehousing offers retailers another area of competitive advantage. It reduces human error, introduces well-organized picking, batch handling, and delivers better more responsive consumer servicing.

Recently the implementation of digital automation into warehousing has increased in-tune with emerging advances in robotics, electronics, connectivities, and computer technologies. This results in: better warehouse functionalities, the ability to communicate with other devices, greater ease-of-use, and greater affordability (Culler et al. 2016).

### **Smart Warehousing - Solution Progressions Towards Automation**

Figure 1a shows Jenkins' (2020) smart warehousing blends stagewise digital process automation components - related to embedded information technologies, with related physical process automation stages to stagewise deliver the integrated and networked components that support warehouse automation. Figure 1b highlights process flows within smart warehouses.

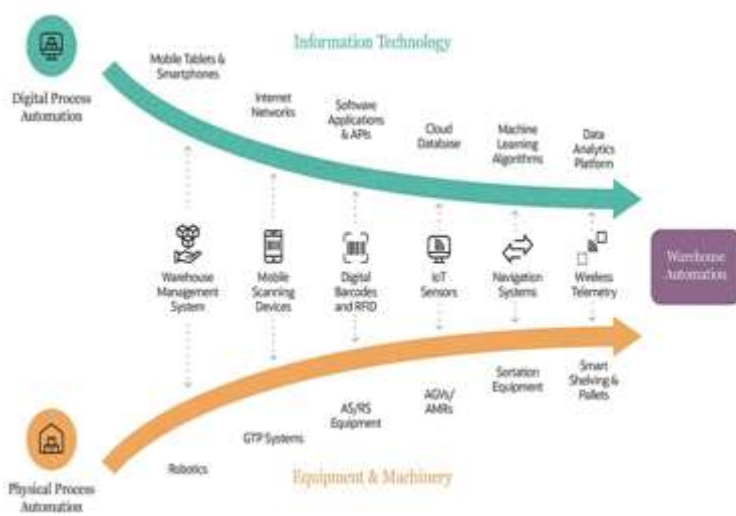

Figure 1a: Smart Warehouse automation (Jenkins, 2020)



Figure 1b: Smart Warehouse (<https://vakoms.com/>)

Automation at the digital process level begins with the programmed inclusion of mobile devices connected by wifi into the warehouse network and its warehouse management system. Software development applications and API's are added to expand intelligence and functionality of storage systems and associated robotics. This increase in data capture makes digital security increasingly important, and requires the introduction of secure cloud database storage systems. As robotic devices expand in function and intelligence machine learning algorithms are introduced and then the entire warehouse management system and its overall data analytics platform is continually recalibrated to deliver required solutions (Jenkins, 2020).

Digital inclusions constitute the middle stagewise increasingly complex transitions. These are matched to above digital process automation stages and to the below physical process automation systems. Digital development inclusions flow from warehouse management systems, to mobile scanners, to digital RFID bar code readers, to IoT/IoE sensors to navigation GPS systems to wireless telemetry directional movements.

Automation at the physical level is again stagewise presents. It begins with the introduction of warehouse management system supported by hardware interfaces collecting and transferring data and robotics control. Goods-to-person fulfilment systems (GPT) increase the warehouse efficiency and reduces congestion by using conveyors, carousels, and vertical lift systems. In high-volume reduced space warehoused, automated storage and retrieval systems (AS/RS) add components to the GTP system by incorporating further automated systems and equipment. This system is best utilised with high-volume reduced space warehouses. Then automatic guided vehicles (AGVs) and autonomous mobile robots (AMRs) provide equipment accessible to operational process routes and typically use laser-guided systems to detect obstacles when navigating these dynamically changing environments and human workforce traffic. Next pick and sort automation is introduced and then smart shelving and pallets provide moveable and changeable solutions (Jenkins, 2020). Thus by 2020 smart warehousing attained considerable advantageous change improvements across autonomous and robotic capabilities.

Today warehousing can operate as a fully-integrated, intelligent, decision-making-by-machines process, that blends suppliers into to warehouse storage requirements and projections, and links though to completion of consumer demand/order requirements. Today smart warehouses can add AI/ GPS tracking/IoE to plot process solutions, digital twinning capabilities to assess and modify storage, 3D/360 degree/mixed realities investigative solutions to define and remedy overall processes and maybe digital systems too, warehouse meshing/advanced planning/ML/predictive analytics to project likely future requirements, dynamic learning and warehouse mesh visualization to describe future solutions. Thus a smart warehouse of th future likey possesses an overall system that understands in a microsecond, manages an unplanned event assesses past experiences uses marketplace intelligences, and ensures value-over-volume.

### **Summary: Australian Smart Warehousing**

Australia has experienced a dramatic increase in e-commerce post the Covid 19 pandemic. Spending reached USD 49 billion in 2021, compared to USD 38 billion in 2020. Seventy-five percent of Australian businesses now earn part of their revenue from online sales, and e/m-commerce accounts for 10 percent of all Australian online sales (DHL Logistics of Things, Insites, 2023).

Online shopping continues to grow as more shoppers shop from their living rooms, with this demand expected to create 490,000 square metres of additional warehouse space per-year for the next few years. This growing trend, has lifted total retail sales thirteen percent (from nine percent in 2020), and sales are expected to rise over twenty percent by 2025 (Schlesinger, 2021).

In today's demand-driven retail economy, online transactions have promoted expansion of both warehousing and distribution centres, and this has pushed a shift towards warehouse automation (JLL Australia, 2021).

The increase in e/m-commerce sales, and the transition from bulk orders, towards single items sales is driving a shft towards more efficient warehousing operations, along with faster process times for online orders. These imperatives have helped secure and retain consumers (DHL Logistics of Things, Insites, 2023).

In 2021 the average consumer expected less than 4.5 days delivery time, compared to 5.5 days in 2012. With online shoppers showing increased expectations of faster deliveries, retailers have quickly recognised the need for smart automated warehousing. consequently, warehouse automation is expected to grow globally by 14 percent by 2026. (JLL Australia, 2021).

Australian retailers are planning and constructing smart, automated warehousing and fulfilment centres. Major Australian retail and logistic players investing millions of dollars in their supply chains and smart warehousing include Amazon, Coles, Woolworths, Australia Post, Booktopia, and online specialists Temple & Webster and Kogan (DHL Logistic of Things, Insites, 2023). Kogan is planning to build an automated warehouse, and Booktopia has invested \$12 Million in an automated Sydney warehouse (JLL Australia, 2021). The supermarket chain Woolworths has announced plans to build two automated warehouses with robotic pickers. Coles is also developing two data fulfilment centres in Melbourne and Sydney to be completed in late 2022 (DHL Logistic of Things, Insites, 2023). Amazon is now operational in Western Sydney with its 200,000 square metres, four-level robotics fulfilment centre. It has been equipped with cutting-edge technology, supported by 1,500 support associates. By incorporating robotics to drive moving inventory pods to associates for picking, packing, and dispatch (Cummins, 2021).

To transition into smart, automated warehousing within its ever-changing Australian marketplaces, warehousing requires broad digital information, operational precision, and ongoing flexibility. The warehouse management system deployed likely features radio-frequency identification (RFID), Internet of Everything (IoE), connectivities, and other digital robotic integrations, activated in real-time, and item tracking across the supply-demand chain (Van Geest et al., 2021). Warehouse management system integration of higher levels of intelligence/assessment software can further: automate the supply-demand chain process, reducing human error, and speed processing. This then increases bottom-line revenue per square meter of warehouse-space by between 10 and 20 percent within an actioned e/m-commerce warehouse management system facility (DHL Logistics of Things, Insites, 2023).

Although the Australian logistics industry has utilized automated/guided vehicles for decades, only recently have necessity-driven innovative developments (including: advanced autonomous driving technologies, flexible picking and manipulation systems, smart storage-wide automation, and capable intelligent robots) been operationalized in warehousing. Robotics systems

controlled by machine learning (ML), and incorporating sensor feedback circuits are now easier to utilize. This allows rapid logistical changes to changing supply-demand environments. (DHL Logistic of Things, Insites, 2023).

Thus smart warehousing, from a literature perspective in Australia, still remains limited. However inherent problems remain across the current supply-demand chain networks and fully-integrated warehouse management systems tend to be firm or site-specific. Hence today larger firm warehouses in Australia are pursuing more efficient, lower cost automated models strategically-aimed at advancing, enhancing, and re-strategising their current warehousing systems.

### Proposed Research Agenda: Approach, Methods, and Techniques

This Post Covid study considers challenges, opportunities, innovations, technologies, connectivities, and risks to enhance and grow future Australian business' commercial (storage/specialist/autonomous) warehousing. It considers smart warehousing a pathway to integrate and coalesce supply/value chain networks by designing fit-for-purpose warehouses offering rapid storage, remixing, and distribution).

Smart warehousing - the centrepiece of Figure 2, encompasses future strategic factors for inbound materials, smart storage, and the outbound remix/repackaging into smart logistical downstreaming.



Figure 2: Warehousing in the business supply and value chain

Smart warehousing matches both the supply side and the demand side requirements, but it must also provide an ongoing sustainable intelligences (and worthwhile) solution. This forms the basis of an initial research model, depicted in Figure 2.

## DISCUSSION

### Future of Smart Warehousing

Today, smart warehousing typically occupies a sizeable integrated facility where systematic-storage of raw materials and/or manufactured items and/or complex item components, is largely managed by networks of integrated digital AI, ML and 3D visualization systems. These digital systems convert input parameters into order fulfilment by delivering intelligent instructions that then: intelligently operate internal, robotic item-movement machines, and specifically position, place, track/record, store a specific item into its appointed, robotically-sized and systematized relational adjustable shelving bin. Order retrieval occurs similarly via bin selection, bin location, bin item extraction, systematic-record-matching, packaging, labelling and shipping.

Incorporating these smart technologies into warehouses likely improves efficiencies, minimizes downtime, and often makes warehousing operations more seamless. For example, today smart warehousing embeds across many supply-demand chains and logistics chains. It deploys: radio-frequency identification technologies (RFID), intelligent autonomous robots, automated digitally-guided vehicles, smart warehouse management and logistics systems, mobile device management, and a raft of integrated Internet-of-Everything smart warehouse technologies tools.

Such toolkits remove reliance upon the human workforce, improve inventory precision monitoring, improve efficiencies, improve accuracy, improve visibility across the supply-demand chain interface, strengthen transparent connectivities with the marketplace, and improve speed across the logistics system. However, this digital system requires considerable initial and ongoing investment, continual ongoing research, and continual system adjustments, along with engaging its' specifically-skilled workforce. Thus, smart warehouses tend to be large, high-throughput, in-demand, high-performance, high efficiency operations that can rapidly self-solve many input-internal-output problems in-situ. Smart warehousing helps: improve the value chain, improve overall quality of delivery, speed net throughput and reliability, lower cost-per-item handled, increase net economic worth, lower overall risk, keep current inventory safe/secure, meet urgent marketplace demands.

Chang et al (2022) offer smart warehousing as a solution to smart retail technologies behavior in smart stores. They suggest hedonic motivation is supplemented via new technologies that arouse consumer curiosity and experienced satisfaction. They show perceived ease of use affects purchasing – with secondary links to quality, price, locational convenience, speed, and recommendations, along with curiosity, joy, immersiveness ,and temporal disassociation. Thus, experiences in smart stores helps drives purchasing, and this provides a need for location-specific smart warehousing. Kembro and Norrman (2022) suggest the future of smart warehousing in retailing is automated, autonomous, digital, connected, and technologies linked to retailers. They further suggest five years into the future retailers are likely to offer their own integrated smart warehousing. Thus smart warehousing into the future automates workflows, utilizes intelligent autonomous and robotics systems, drives efficiencies, and optimizes processes and connectivities.

## CONCLUSION

This study seeks to expand knowledge on Australia's readiness to adopt smart warehousing. It seeks answers concerning Australia's best future directions in utilizing smart warehousing into the future. This Australian research study now sets out to first capture and assess existing warehousing supply resources orchestration conditions. Next, it considers enablers and barriers to delivering smart warehousing demand-driven resources orchestration actions - as supply-demand near-real-time transacting solutions. Finally, it maps these supply-demand resource orchestration components of smart warehousing as likely coalesced-contributors towards a sustainable pathway into the future, and within the Australian context.

Data collection is targeted from existing Australian Stock Exchange businesses to broadly cross-section different industries (including retailing, health, mining, foods, and construction/engineering). These typically larger institutions or firms frequently draw on storage warehousing as an integral (and often just-in-time) part of their inbound and/or outbound B2B or B2C logistics. Data capture is structured using: (1) a Likert scale (1-5) online (quantitative) Qualtrics survey, and (2) a semi-structured, qualitative, open-ended question section Qualtrics survey inclusion.

Using quantitative data capture techniques, this stagewise combination of contributing components facilitates statistical investigation options using either smart PLS, or structural equation modelling, or possibly multi-level Mplus modelling. Figure 3 enables capture of these component measurement domains into a suitable quantitative three stage framework structure. A series of qualitative open-ended questions attached to the quantitative survey. The qualitative analysis tool NVivo and its theme-based analysis processes can provide word cloud, word tree, project map, and 3D spatial analysis, and these collectively can further verify the quantitative modelling solution.



Figure 3: Proposed Research Framework

Figure 3 is statistically approached via quantitative (SEM, PLS, or MPlus) modelling. This modelling approach can expose comparison between significant standardized relationships. It can provide standardized total effects pathways operating across the three-stage model. It can present and elucidate the extent of demand, supply, and conjoint demand-supply influences, and how these then exert a network influence onto warehouse sustainability intelligences. It also likely offers further insight(s) into where, and how, Australia can best progress its smart warehousing into the future.

Further, by understanding Figure 3's supply-demand network, and the degree each of its' components contribute, it is then possible to code modify a warehouse management system to better represent the Australian smart warehouse situation. This likely includes the warehouse management system being capable of: (1) instantly transmitting each item's collected relevant data, (2) instantly analysing each item's collective data, and (3) instantly intelligently deciding where it can be best-placed to deliver optimal beneficial intelligent (and worthwhile) sustainable outcomes across its warehousing storage and movement requirements.

## REFERENCES

- Ballantyne, A., & McFarlane, A. (2022). JLL Logistics and Industrial Market Overview, Q4 2022. Retrieved from: <https://www.jll.com.au/en/trends-and-insights/research/australian-industrial-market-overview-4q22>, (accessed 16th March 2023).
- Burston, B., Ciesielski, M., Wilson, J., & Kaliza, L. (2023). Navigating The Path To Performance. Knight Frank Outlook-Report, 2023-9619, pp. 1-36. Retrieved from: <https://content.knightfrank.com/research/2156/documents/en/outlook-report-2023-9619.pdf>, (accessed 16th March 2023).
- Celik, M., & Sural, H. (2019). Order picking in parallel-aisle warehouses with multiple blocks: complexity and a graph theory-based heuristic. *International Journal of Production Research*, 57(3), 888-906.
- Chang, Y. W., Hsu, P. Y., Chen, J., Shiao, W. L., & Xu, N. (2023). Utilitarian and/or hedonic shopping—consumer motivation to purchase in smart stores. *Industrial Management & Data Systems*, 123(3), 821-842.
- Cheng, S. W., Choy, K. L., & Lam, H. Y. (2015). A workflow decision support system for achieving customer satisfaction in warehouses serving machinery industry. *IFAC-PapersOnLine*, 48(3), 1714-1719.



- Chung, S. H. (2021). Applications of smart technologies in logistics and transport: A review. *Transportation Research Part E: Logistics and Transportation Review*, 153, 102455, 1-17.
- Culler, D., & Long, J. (2016). A prototype smart materials warehouse application implemented using custom mobile robots and open source vision technology developed using emgucv. *Procedia Manufacturing*, 5, 1092-1106.
- Cummins, L. (2021). Amazon Robotics fulfilment centre. Retrieved from: <https://www.aboutamazon.com.au/news/economic-impact/construction-of-the-largest-warehouse-ever-built-in-australia-is-well-underway-creating-jobs-for-western-sydney>, (accessed 16th March 2023).
- DHL Logistic of Things, Insites, (2023). Australia's E-Commerce Companies Are Getting A Boost With Warehouse Automation. Retrieved from: <https://lot.dhl.com/australia-e-commerce-boost-warehouse-automation/>, (accessed 16th March 2023).
- Ding, W. (2013). Study of smart warehouse management system based on the IOT. In *Proceedings Intelligence Computation and Evolutionary Computation: Results of 2012 International Conference of Intelligence Computation and Evolutionary Computation ICEC 2012*, (pp. 203-207), 7 July, Wuhan, China.
- Henderson, J., Crawford, L., Birch, J., Potter, N., Halai, Y., Salar, R., & Lu, C. (2022). Colliers Outlook for Australian Warehouse Demand, Q2 2022. Colliers PowerPoint Presentation, pp. 1-11 Retrieved from: <https://www.Colliers.com.au/download-article?itemid=c14c8b87-f25b-4b6f-b3ab-1025e1dc3138>, (accessed 16th March 2023).
- Immerman, G. (2019, April 17). Industry 4, The History, Benefits, and Technologies. Retrieved from: <https://www.machinemetrics.com/blog/what-is-industry-4-0>, (accessed 17th March 2023).
- Jenkins, A., (2020). Warehouse Automation Explained: Types, Benefits & Best Practices. Retrieved from: <https://www.netsuite.com/portal/resource/articles/inventory-management/warehouse-automation.shtml>, (accessed 17th March 2023).
- JLL Australia. (2021). Smart warehouses spread to new markets: Retailers are turning to robots amid rising expectations for fast deliveries. Retrieved from: <https://www.jll.com.au/en/trends-and-insights/investor/smart-warehouses-spread-to-new-markets>, (accessed 16th March 2023).
- Kembro, J., & Norrman, A. (2022). The transformation from manual to smart warehousing: an exploratory study with Swedish retailers. *The International Journal of Logistics Management*, 33(5), 107-135.
- Kumar, S., Narkhede, B. E., & Jain, K. (2021). Revisiting the warehouse research through an evolutionary lens: a review from 1990 to 2019. *International Journal of Production Research*, 59(11), 3470-3492.
- Mahmut, T. (2022). Warehousing 4.0 In Logistics 4.0 In Ismail, Lyigun & Omer Faruk Gorcun (Eds.). *Logistics 4.0 and Future of Supply Chains (Accounting, Finance, Sustainability, Governance & Fraud: Theory and Application)* 1st ed., Singapore: Springer.
- Pontius, N. (2018). *The Complete Guide to Warehouse Automation: Basics of Organization and Warehouse Labeling, Automation Technologies, Best Practices, and More*. Industry Resources, Warehouse Labels. Retrieved from: <https://www.camcode.com/blog/guide-to-warehouse-automation/>, (accessed 16th March 2023).
- Schlesinger, L. (2021). Financial review "Australia plays 'Catch' up on e-commerce-led warehouse boom." Retrieved from: <https://www.afr.com/property/commercial/australia-plays-catch-up-on-e-commerce-led-warehouse-boom-20210615-p5813y>, (accessed 16th March 2023).
- Severns, M. (2022). Creating the Warehouse of the Future. Dec. p.1, Retrieved from: <https://blog.blueyonder.com/creating-the-warehouse-of-the-future/> (accessed 16th March 2023).
- Tikwayo, L. N., & Mathaba, T. N. (2023). Applications of Industry 4.0 Technologies in Warehouse Management: A Systematic Literature Review. *Logistics*, 7(2), 24, 1-19.
- Van Geest, M., Tekinerdogan, B., & Catal, C. (2021). Smart Warehouses: Rationale, Challenges, and Solution Directions. *Applied Sciences*, 12(1), 219. 1-16.
- Wang, Q., Alyahya, S., Bennett, N., & Dhakal, H. (2015). An RFID-enabled automated warehousing system. *International Journal of Materials, Mechanics and Manufacturing*, 3(4), 287-293.
- Zhang, D., Pee, L. G., & Cui, L. (2021). Artificial intelligence in E-commerce fulfillment: A case study of resource orchestration at Alibaba's Smart Warehouse. *International Journal of Information Management*, 57, 102304, 1-15.
- Zhou, W., Piramuthu, S., Chu, F., & Chu, C. (2017). RFID-enabled flexible warehousing. *Decision Support Systems*, 98, 99-112.
- Zunic, E., Delalic, S., Hodzic, K., Besirevic, A., & Hindija, H. (2018, November). Smart warehouse management system concept with implementation. In *Proceedings 2018 14th Symposium on Neural Networks and Applications (NEUREL)* (pp. 1-5). IEEE, Belgrade Serbia, 20-21 Nov.

## Design and Application of Artificial Intelligent Fire Fighting Robot and Development of Data Module

Jian-Jun Hou <sup>1,\*</sup>  
Yu Tang <sup>1</sup>  
Li Chen <sup>1</sup>  
Wen-Min Chen <sup>1</sup>

\*Corresponding author

<sup>1</sup> School of Art and Design, Nanjing Institute of Technology, Nanjing, Jiangsu, China, houjianjun@njit.edu.cn

### ABSTRACT

By systematic analysis, the existing AI technology and fire-fighting robot were combined effectively. Then, an AI-based fire-fighting robot was designed through design orientation, design sketch and structure analysis, and functional analysis. Finally, specific data modules were developed, making the robot available to analyze fire, allocate tasks, and acquire UAV data intelligently. The AI-based fire-fighting robot is composed of a fire-fighting robot and a monitoring UAV. Based on AI technology, it is embedded with a task allocation module, alarm module, flight regulation module, positioning module, timing module, flight scanning module, data analysis module, data acquisition module, and signal receiver/sender module.

*Keywords:* Fire-fighting Robot, Monitoring UAV, Artificial Intelligence (AI) Technology, Data Module Development

### INTRODUCTION

The fire-fighting robot which is for extinguishing fire in an extreme environment has many operational functions such as radiation protection, remote control, walking, water cannon control. By function, there are the crawler-type fire-fighting robot, the climbing fire-fighting robot, the multi-function fire-fighting robot, and the large fire-fighting robot; by movement mechanism, there are crawler type, leg type, wheel-legged type, and wheel-crawler type, which have specific advantages in different application scenes. Among them, the crawler-type robot can get across a complex ground and can bear strong recoil while spraying water for firefighting. Hence, this type of robot is popular in the market. With the development of artificial intelligence (AI) technology, an AI-based fire-fighting robot can detect and evaluate the fire environment accurately, analyze and select the optimum fire extinguishing method intelligently, identify, search, and rescue any signs of life, and put out the fire precisely.

### STUDIES ON THE TECHNOLOGIES OF FIRE-FIGHTING ROBOT

#### Arduino Single Chip Microcomputer Technology

With Arduino single-chip microcomputer technology, a fire-fighting robot that can avoid barriers while extinguishing fire (Vivekanadan et al., 2016). The Arduino UNO micro-controller to monitor the operation of the robot and simulated the entire robot model by using Proteus (Raju et al., 2018). Marhoon designed a kind of tank robot for extinguishing fire in a closed area based on Arduino micro-controller, flame sensor, and motion sensor (Marhoon et al., 2021).

#### STM32 Control Technology

There were also concentrated studies on the fire-fighting robot based on STM32 control technology. Typically, Guang team designed an STM32-based intelligent fire-fighting robot (Guang et al., 2014). Gao created an STM32-based intelligent path-tracking robot and adjusted the robot in the walking process based on the traditional PID control theory (Gao et al., 2014).

#### Neural Network and Fuzzy Logic Technology

The fire-fighting robot can operate and respond based on the neural network and fuzzy logic technology to detect the external environment. In 1998, Yan Z developed an online algorithm for the related neural network of a fire-fighting robot. In 2019, Navyanth (2019) embedded a fuzzy logic control system in the fire-fighting robot so that the robot could reach the target area and extinguish the fire safely. Santis team used a fuzzy inference system that can generate the task space trajectory of the robot automatically and tested the performance of the entire system in a typical interference scene by studying simulated cases (Santis et al., 2006). In 2011, Tavera M proposed a chaotic control for mobile robots so that the robots can move within a regular space to maximally reduce harm to people, objects, and the environment. In 2021, Ramasubramanian (2021) put forward a path-planning algorithm and investigated four path-planning algorithms (namely Probabilistic Roadmaps, Rapidly Exploring Random Tree, Rapidly Exploring Random Tree Star, and A star (A\*)) to get the most effective autonomous path for the fire-fighting robot.

#### Other New Intelligent Technologies



With the use of flame detector, path-planning algorithms, infrared imaging method, VR, and UAV, the fire-fighting robot becomes more and more intelligent. Taking a flame-pattern algorithm-based new search method, Parmar team designed a fire-fighting robot that can detect flame and extinguish it safely (Parmar et al., 2011). Hassanein developed a robot that can position and extinguish fire in a given environment and evade any obstacle in roaming (Hassanein et al., 2015). Rakib team studied the design and manufacture of a multi-sensor fire detection system (MSFDS) and a PID control-based MSFD-independent fire-fighting robot (Rakib et al., 2016). Based on GSM technology and single chip microcomputer, an image processing system and communication structure be designed for fire-fighting robots to help firemen better understand the fire behavior and the positions of the trapped persons (Madhevan et al., 2017). It is crucial for saving time and reducing the rescuers' life risks. In 2020, Zhu J came up with an infrared image-based intelligent fire monitor feedback control system aiming at having the fire water cannon pointed to the horizontal position of the fire intelligently by adjusting the yaw angle of the fire monitor. This feedback control system has a large potential of being used for intelligent fire extinguishing of the fire-fighting robot. In the same year, Nie F designed a motion control system for fire-fighting robots, where the camera on the water cannon can send image feedback to the VR glasses of the operator for visual synchronization. The firemen increasingly prefer the UAV with an advanced imaging device to enhance their awareness of the situation and help cope with wildfire (Bogue et al., 2021).

### The Designs of Fire-Fighting Robot

Dearie team conceived an intelligent fire-fighting robot with situation awareness, navigation, detection, and fire extinguishing functions (Dearie et al., 2002). Altaf team designed a fire-fighting robot that has differential driver control, obstacle avoidance, environment sensing, electronic circuit design, navigation (straight-line tracking) functions (Altaf et al., 2007). Based on ARM9 (as the core controller), Bin LI used an infrared ranging sensor and a far infrared flame sensor to monitor the distance and source of the fire so that the intelligent robot can put out the fire in any room within 8 seconds (Bin LI et al., 2010). Besides, Shi X developed a new intelligent wireless fire monitoring system based on NB-IoT technology (Narrow Band - Internet of Things), realizing the in-time remote monitoring and control of the fire-fighting robot (Shi et al., 2020).

### MARKET DEMAND OF FIRE-FIGHTING ROBOT

America's robot ASH can automatically judge and find the fire source on a ship and extinguish the fire with applicable methods. When the place and intensity of the fire are unclear, rescuers can operate the robot by gesture signal in a safe area.

Thermite is a tank-shaped robot with a small size. It applies to extremely dangerous zones such as oil refineries, chemical plants, nuclear reactors, and other places with flammable chemicals. Due to its shape, this robot adopts crawler-type so that it can move over the rugged disaster area. It can be mounted with detection equipment easily as required and a manipulator arm for observing and evaluating the search, cleaning, and other operations.

Australia's fire-fighting robot TAF20 is designed with a turbine to assist with fire extinguishing. It can spray water as far as 90 meters. Even, the foam can be sprayed for 60 meters through the turbine. This robot has built-in fans sufficient to wipe off dense smoke for rescuers.

Germany's snow-making fire-fighting vehicle LUF60, produced by Schmitz, can cool down, dilute, discharge smoke, and extinguish fire. Its control distance is 300 meters. The common fire-fighting robots in the market in Figure 1.



Figure 1: The common fire-fighting robots in the market

To deeply understand the existing market share and usage of fire-fighting robots, a Fire-Fighting Robot Market Survey Questionnaire was designed and distributed to firemen or fire control-related workers both online and offline. Finally, 100 copies were distributed, and 94 copies were collected. The survey results are displayed in Figure 2.

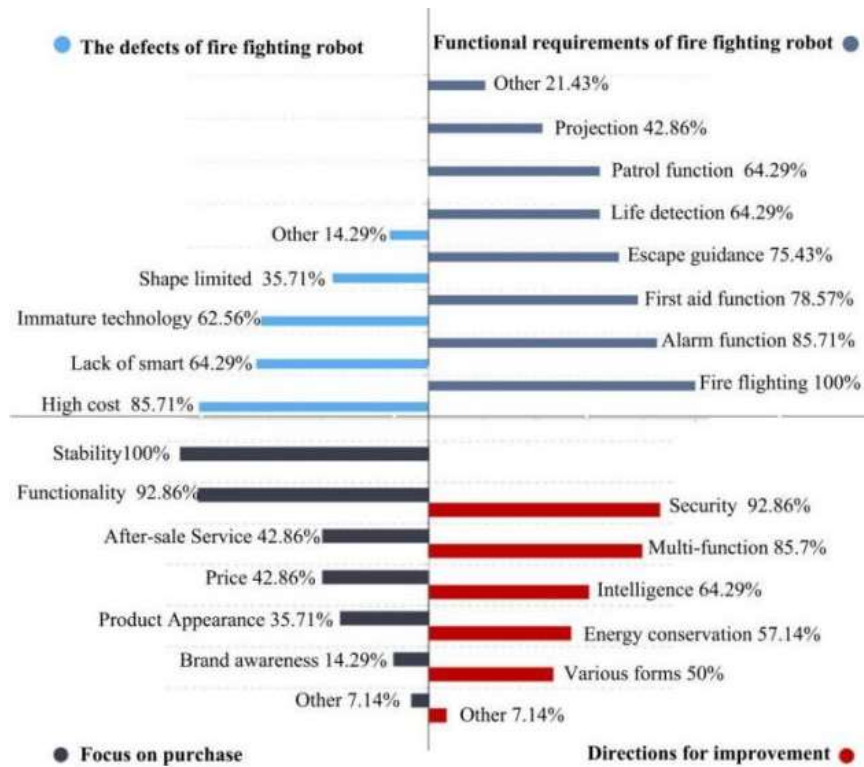

Figure 2: The questionnaire survey and analysis of fire fighting robot market

## DESIGN OF THE INTELLIGENT CRAWLER-TYPE FIRE-FIGHTING ROBOT

### Design Orientation and Sketch

In this study, a kind of intelligent crawler-type fire-fighting robot consisting of a fire-fighting robot (the main body) and a monitoring UAV was designed based on the design considerations of a fire-fighting robot, the design flow and method of a product, and the AI technology. It applies to high-temperature, poisonous, and other high-risk environments. The monitoring UAV can identify the signs of life, judge the fire source, and investigate risks, while the robot can enter narrow spaces to extinguish fire and rescue people. The design sketch of this robot is exhibited in Figure 3.



Figure 3: Design renderings of firefighting robot

### Internal Structure

The internal structures of the main body and the monitoring UAV are presented in Figure 4 and the names and functions of the structures are listed in Table 1.

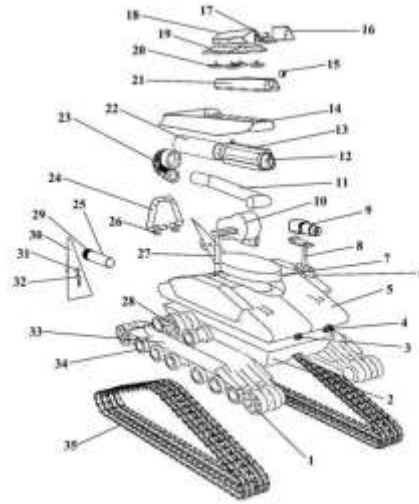

Figure 4: Structural design of fire fighting robot

Table 1: Structure name and functions of fire fighting robot

NO.	Name	Function	NO.	Name	Function
1	Guide Pulley	Control the track	2	Drive Motor	Driving crawler motor device
3	Temperature Sensor	Sensing ambient temperature	4	Damper	Absorb the vibration caused by the road surface
5	Outer Frame	Shell of firefighting robot	6	PTZ	Fixed camera equipment
7	Base	Camera bracket base	8	Bracket	Camera rotatable support
9	Camera 1	The robot body detects the external conditions	10	Drive motor	Drive water cannon motor device
11	Return Tube	Return drainpipe	12	Waterspout	Water spray outlet
13	Water Jet Gun Head	Spray water column or spray water mist function	14	Upper cover of water cannon	Water cannon protective cover
15	Camera 2	UAV detection of external conditions	16	Transparent Lampshade	Protective detector transparent cover
17	Infrared Rangefinder	Infrared measuring distance	18	UAV Upper Shell	UAV shell protection
19	Folding Wing	Folding wings reduce space	20	Three Rotor Flying Propeller	UAV flight device
21	UAV lower shell	UAV shell protection	22	Straight water pipe	Straight shape outlet pipe
23	Folding Telescopic Tube	Telescopic outlet pipe	24	Water Pipe Tail Support	Water cannon shell
25	Water Inlet Pipe	Fire hose connection	26	Retaining Ring	Fixed water pipe
27	Lifting Support Column	Lifting support mechanism of water cannon	28	Drive wheel	Realize the operating power of machinery
29	Quick Connector	Fast replacement according to the nature of fire source	30	Cover	Shell of firefighting robot
31	Warning Light	Warning function lamp	32	Standard Lamb	Illumination Function Lamp
33	Chain Box	Protective Chain	34	Load Bearing Wheel	Carrying the weight of the robot and the recoil force generated during spraying
35	Track	Robot action mode			

## Functions

### Fire Extinguishing

This function is mainly performed by the fire water cannon. The water cannon can atomize water or switch to flow water and regulate the pitching angle up and down. It is made of hard anodized aluminum alloy, with high corrosion resistance, and is connected to the upper cover so that it cannot be damaged by falling objects or in case of an explosion.

### Motion

The robot's motion mechanism is Crawler type movement mode. The crawler adopts a triangular design, ensuring the stability of the entire robot while moving over obstacles. Considering the application in severe environments, the crawler is wide and large, with a rotation shaft in the middle to facilitate 360° rotation. With this design, the robot can run on uneven ground freely.

### UAV

To assist in the rescue, the UAV can fly in the upper air or enter a room to detect any sign of life and risk, get familiar with the fire environment, process the image with the camera, and transmit the image to the command in time. The tree-rotor propeller is under the folded wings to protect the wings from being damaged by falling objects. The infrared detector and LED lamp are placed in a transparent lampshade to protect them from damage in the complicated case of fire. The design of UAV as shown in Figure 5.



Figure 5: The design of UAV

**Intelligent Identification**

The fire-fighting robot has an obstacle avoidance and fire source positioning system, which adopts an exclusive radio frequency identification system to observe the surrounding condition in time and select an optimum obstacle avoidance scheme. If there are over many sundries on the ground, the robot will choose to move over the sundries smoothly to reach the appointed fire site most efficiently. Further, based on the data sent by the UAV, the robot can determine the position of the fire source, and regulate the tilt and turning angle of the fire water cannon, which can greatly save the rescue time.

**Reconfiguration**

The fire extinguishing method can be changed with the nature of the fire source. There is a quick connector in the rear of the robot. Inside the connector, there are water column and water mist modes. The applicable mode is switched to once the exact fire extinguishing method is identified intelligently. Then, the robot can extend the upper fire water cannon as per the floor height of the fire source by lifting the support system, folding the extension tube, and operating the head convector of the water cannon. Thus, the fire-fighting efficiency is improved.

**The Application of AI Technology**

AI technology is used in many aspects of the fire-fighting robot such as the output system, input system, control system, and communication system so that the robot can evaluate and detect natural disasters, work instead of manpower in a high-risk environment, assist in the analysis, evaluate and deal with high risks. Application of artificial intelligence technology in firefighting robot as shown in Figure. 6.

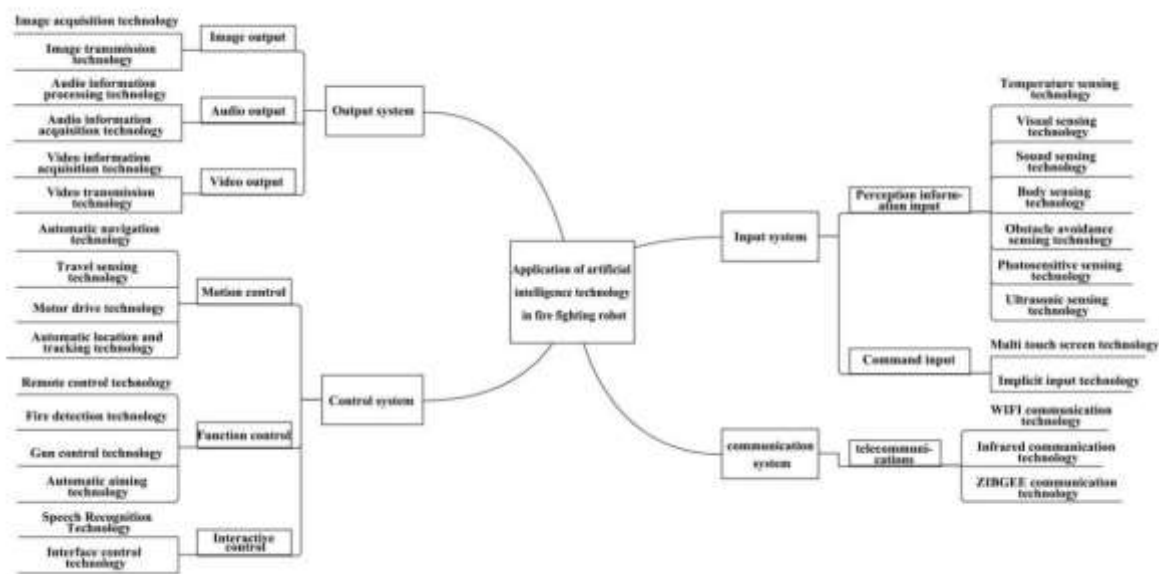

Figure 6: Application of artificial intelligence technology in firefighting robot

**Output system**

With AI technology, the system can sort out and classify the acquired images, audio, and video, and display targeted information (such as the fire intensity, signs of life, and internal fire status) on the interface to reduce the rescue time and rescue with correct methods.

**Control system**

Via AI technology, the system can efficiently control the robot’s motion, functions, and interaction. In terms of motion, the system can control the robot reaching a designated area based on its automatic navigation. Through motor driving and walking sensing technology, the spreading of fire can be tracked and positioned. With the control function, the robot can be operated remotely to detect the fire status, control the spraying angle of the water cannon, and aim at the fire source. Moreover, the interaction control function makes it available to operate the robot both by voice and touching the interface in emergency rescue, hence saving the rescue time greatly.

**Input system**

The sensing system can identify and input perceptual information such as temperature, vision, sound, body feeling, obstacle avoidance, photo sensitivity, and ultrasonic wave to guarantee the robot’s safe operation and rescue. Meanwhile, the command input function is also made available based on multi point touch-screen technology and implicit input technology.

**Communication system**

With AI technology, the fire-fighting robot can operate automatically through wireless communication. The robot’s intelligent operation is mostly controlled by WIFI, infrared, and ZIGBEE communication technologies.

**CONTROL SYSTEM DESIGN AND DATA MODULE ANALYSIS OF THE INTELLIGENT FIRE-FIGHTING ROBOT**

**Control System Design**

Based on AI technology, the controllers for the fire-fighting robot and UAV are embedded with signal receiver/sender modules, positioning modules, timing modules, data analysis modules, data acquisition modules, alarm modules, and so on. Additionally, the controller of the UAV is mounted with the flight scanning module and obstacle analysis module, as shown in Figure 7.

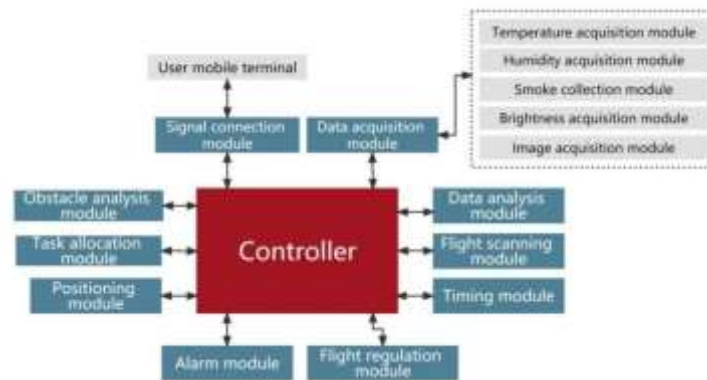

Figure 7: The control system design of the intelligent fire-fighting robot

**Analysis Steps of the Fire Analysis Module**

The analysis steps and calculation methods are listed below:

- Step 1: Acquire the temperature (WD), humidity (SD), smog intensity (YW), and brightness (LD) of the external environment.
- Step 2: Work out the value of the external environment (HJ) based on the following formulas:

$$HJ = \sqrt{\frac{WD \times c1 + YW \times c3 + LD \times C4}{SD \times c2}} \tag{1}$$

( c1 、 c2 、 c3 and c4 are preset fixed numbers of proportional coefficients )

- Step 3: Obtain the length and width of the external image by the camera and calculate the total pixels of this image.
- Step 4: Search the entire external image to get the pixels of the flame color (including dark red, red, orange, yellow, blue-white, and white) and calculate the pixel proportion of the flame color (HZ).
- Step 5: Calculate the fire alarm value (HY) of the external environment as per the following formula based on the HJ and HZ based on the following formulas:

$$HY = \sqrt{\frac{(HJ - HZ)^2}{(HZ + HJ)^2} + \frac{(HJ + HZ)^2}{(HZ - HJ)^2} + \frac{(HZ - HJ)^2}{(HZ + HJ)^2} + \frac{(HJ + HZ)^2}{(HJ - HZ)^2}} \tag{2}$$

- Step 6: Generate a fire alarm signal and load it to the alarm module when the value of HY is greater than the designed threshold.

**Analysis Steps of the Task Allocation Module**

When the value of HY is greater than the designed threshold, the task allocation module works in the following steps (Figure. 8):

- Step 1: Make clear the fire brigades in idle state and mark them as i (i=1, …, n);
- Step 2: Acquire the total number of firefighting tasks (Xzi) of the fire brigade and its number of successful firefighting tasks (Xci) and work out the success rate of the fire brigade:

$$Xi = Xci / Xzi \tag{3}$$

- Step 3: Obtain the current number of firefighting tasks of the fire brigade and mark it as Xri; obtain the firefighting duration of the fire brigade and work out its average firefighting duration (Xpti) based on the SUM and AVERAGE formulas.
- Step 4: Use the following formula to calculate the recommendation value of the fire brigade (Xtj) based on the following formulas:

$$Xtj = \sqrt{Xi \times a1 + Xri^{a2} + Xpti \times a3} \tag{4}$$



( a1 、 a2 and a3 are fixed values of preset proportional coefficients )

Step 5: Select the top 3 fire brigades (by recommendation value) as alternates j (j=1, 2, 3).

Step 6: Work out the duration of the fire brigade since its establishment (E<sub>tj</sub>) based on the current time.

Step 7: Create a rectangular coordinate system taking the place of fire as the origin and calculate the fire brigade's straight-line distance from the place of fire (Dis<sub>j</sub>) based on the formula of the distance between two points:

Step 8: Calculate the firefighting value (M) of the fire brigade based on the following formula:

$$M = X_{tj}^{E_{tj} \times b_1} + A_{tj} \times b_2 - \sqrt{|Dis_j \times b_3|} \tag{6}$$

( b1 、 b2 and b3 are fixed numerical values of the preset scale coefficients )

Step 9: Determine the fire brigade with the highest firefighting value (M) and select it to do the task. In the meantime, the number of firefighting tasks of the fire brigade is added by one.

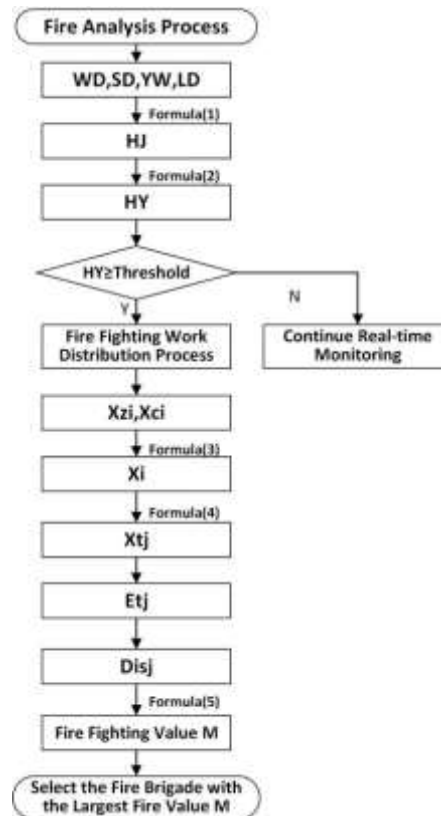

Figure 8: Analysis steps of the task allocation module

### Analysis Steps of the UAV Data Acquisition Module

The data acquisition module is used for acquiring the operation information of the robot and the flight information of the UAV; the data analysis module is for analyzing the flight information of the UAV in the following steps (Fig. 9):

Step 1: Obtain the preset flight time (YT), preset flight speed (YS), preset flight height (YG), and preset flight trajectory (YJ) of the UAV.

Step 2: Set several time nodes at a fixed time interval (t) to divide the UAV's flight route into several segments a (a=1, ..., n);

Step 3: Obtain the UAV's flight speeds at the beginning and end of each segment a, then take their average value and treat it as the UAV's flight speed (S<sub>a</sub>) in this segment;

Acquire the number of segments (b) in which the S<sub>a</sub> exceeds YS, and then calculate the number of segments (a-b) in which the S<sub>a</sub> does not exceed YS.

Compare b and a-b;

If b ≥ a-b, generate a flight regulation signal;

If b < a-b, enter the next step;

Acquire the number of segments (c) in which G<sub>a</sub> exceeds YG, and then calculate the number of segments (a-c) in which G<sub>a</sub> does not exceed YG.

Compare c and a-c.

If c ≥ a-c, generate a flight regulation signal;

If c < a-c, enter the next step;

Step 5: The segments  $a$  are set corresponding to a fixed time interval  $t$ ; based on the formula  $TM=axt$ , the UAV's actual flight time is calculated. If the difference between the actual flight time  $TM$  and the preset flight time ( $YT$ ) is within the designed threshold, the next step is entered; otherwise, the module generates a flight regulation signal.

Step 6: Establish a three-dimensional coordinate taking the place of fire as the origin and display the segments  $a$  in the coordinate in points; then calculate UAV's flight trajectory based on the following equation:

$$\begin{cases} X = \alpha \times \sin \eta \\ Y = \beta \times \cos \eta \\ Z = \gamma \times \tan \eta \end{cases} \quad (7)$$

( $\alpha$ 、 $\beta$  and  $\gamma$  Are preset scale coefficients,  $\eta$  Is an argument)

Step 7: Use the positioning module to obtain the UAV's current position in the three-dimensional coordinate and compare it with the preset position in the current time;

Step 8: The generated flight regulation signal is sent to the flight regulation module, which is used for receiving this signal; then, the module regulates the UAV's flight speed, flight height, flight trajectory, and flight time as per the flight regulation signal.

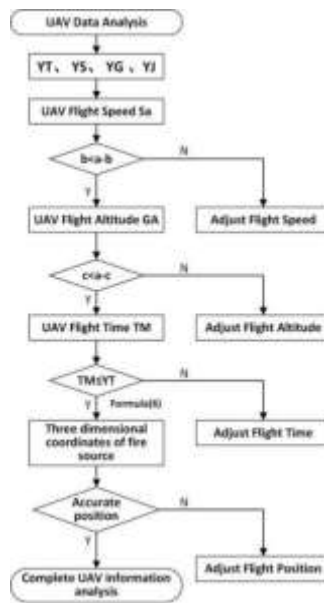

Figure 9: Analysis Steps of the UAV Data Acquisition Module

### CONCLUSION

The intelligent fire-fighting robot is incorporated with modern and intelligent elements in shape and combines with a monitoring UAV. By using AI technology, the entire robot is embedded with the task allocation module, alarm module, flight regulation module, positioning module, timing module, fight scanning module, data analysis module, data acquisition module, and signal receiver/sender module. Thus, it realizes the interaction between the overland and aerial modes. The UAV can patrol and plan the path, make intelligent analysis, monitor continuously at a fixed point, and alarm in case of fire, while the robot can enter a narrow place of fire, determine the type of fire source intelligently, and regulate the tilt and turning angle of the fire water cannon based on the data sent by the UAV. Hence, a great deal of rescue time can be saved.

Inside the UAV, there is a data analysis module, which can analyze the hidden risk of fire in the external environment. In detail, it can obtain the data of the external environment (including the temperature, humidity, smog intensity, and brightness) and calculate the value of the external environment. Further, it can work out the fire alarm value of the external environment as per the pixel proportion of the flame color in the external image. With this design, the UAV can send an alarm and deal with any hidden risk of fire quickly to avoid expansion of the fire.

### ACKNOWLEDGMENT

Fund Project: sponsored by Qing Lan Project 2023;The Philosophy and Social Science project of Jiangsu Province (No.2022SJYB0443);The Ministry of Education Human Society project of China (No.22YJC760024); The Social Science Research in Colleges and Universities in Jiangsu Province (No.2022SJZD115); Excellent Project of Jiangsu Social Science Application Research (No.22SYC-010);Key Research Topics in Higher Education (No.2023GJZD03);Post-graduate Education Teaching Reform Project (No.2023YJYJG08); Postgraduate Textbook Construction Project (No.2022JC09).

### REFERENCES



- Altaf, K., Akbar, A., Ijaz, B. (2007). Design and Construction of an Autonomous Fire Fighting Robot. In *International Conference on Information & Emerging Technologies, 2007*. <https://doi.org/10.1109/ICJET.2007.4381341>.
- Bogue, R. (2021), "The role of robots in firefighting", *Industrial Robot*, 48 (2), 174-178. <https://doi.org/10.1108/IR-10-2020-0222>
- Dearie, S., Fisher, K., Rajala, B., et al. (2002). Design and construction of a fully autonomous firefighting robot. In *Electrical Insulation Conference & Electrical Manufacturing & Coil Winding Conference, 2002*. <https://doi.org/10.1109/EEIC.2001.965638>.
- Guang-Wu, H. U., Sheng, Z., Qing-Peng, R., et al. (2014). Design of Intelligent Fire-fighting Robot Based on STM32 Control. *Automation Application, 2014*.
- Hassanein, A., Elhawary, M., Jaber, N., et al. (2015). An autonomous firefighting robot. In *International Conference on Advanced Robotics, 2015*. <https://doi.org/10.1109/ICAR.2015.7251507>.
- Li, L., Hang, J., Gao, Y., et al. (2017). Using an Integrated Group Decision Method Based on SVM, TFN-RS-AHP, and TOPSIS-CD for Cloud Service Supplier Selection. *Mathematical Problems in Engineering, 2017, 2017, 1-14*. <https://doi.org/10.1155/2017/6012503>.
- Li, L., Hang, J., Sun, H., et al. (2020). Digital Twin Driven Green Performance Evaluation Methodology of Intelligent Manufacturing: Hybrid Model Based on Fuzzy Rough-Sets AHP, Multistage Weight Synthesis, and Promethee II. *Complexity, 2020, 2020(6), 1-24*. <https://doi.org/10.1155/2020/8849635>.
- Li, L., Lei, B., Mao, C. (2022). Digital Twin in Smart Manufacturing. *Journal of Industrial Information Integration, 26(9), 100289*. <https://doi.org/10.1016/j.jii.2021.100289>.
- Li, Y., Li, L. H. (2020). Enhancing the Optimization of the Selection of a Product Service System Scheme: A Digital Twin-Driven Framework. *Strojnicki Vestnik-Journal of Mechanical Engineering, 66(9), 534-543*.
- Liu, X., Han, L. (2022). Artificial Intelligence Enterprise Management Using Deep Learning. *Computational Intelligence and Neuroscience, 2022, Article ID 2422434, 10 pages*. <https://doi.org/10.1155/2022/2422434>.
- Madhevan, B., Ramanathan, S., Jha, D. K. (2017). A Novel Image Intelligent System Architecture for Fireproof Robot.
- Maroon, H. M. (2021). Implementation of rover tank firefighting robot for closed areas based on Arduino microcontroller. *Indonesian Journal of Electrical Engineering and Computer Science, 21(1), 56-63*. <https://doi.org/10.11591/v21.i1.pp56-63>.
- Mosleh Hmoud Al-Adhaileh, Theyazn H. H. Aldhyani, Fawaz Waselallah Alsaade, Mohammed Al-Yaari, Ali Khalaf Ahmed Albaggar (2022). Groundwater Quality: The Application of Artificial Intelligence. *Journal of Environmental and Public Health, 2022, Article ID 8425798, 14 pages*. <https://doi.org/10.1155/2022/8425798>.
- Navyanth, K., Jacob Navigation of Autonomous Firefighting Robots Using Fuzzy Logic Technique. (2019).
- Nie, F., Wei, H., Li, F., et al. (2020). Design of Motion Control System for Fire Fighting Robot. *Journal of Physics: Conference Series, 1635(1), 012059 (5pp)*. <https://doi.org/10.1088/1742-6596/1635/1/012059>.
- Parmar, D. (2011). Design and implementation of an autonomous firefighting robot. *University of Guelph (Canada)*.
- Qu, T., Huang, T. X., Nie, D. X., Fu, Y. L., Ma, L., Huang, G. Q. (2022). Joint Decisions of Inventory Optimization and Order Allocation for Omni-Channel Multi-Echelon Distribution Network. *Sustainability, 14(10), Article ID 5903*. <https://doi.org/10.3390/su14105903>.
- Rakib, T., Sarkar, M. A. R. (2016). Design and fabrication of an autonomous firefighting robot with multisensor fire detection using PID controller. In *International Conference on Informatics, 2016, 909-914*. <https://doi.org/10.1109/ICIEV.2016.7760132>.
- Ramasubramanian, S., Muthu Kumaraswamy, S. A. (2021). On the Enhancement of Firefighting Robots using Path-Planning Algorithms. *SN Computer Science, 2(3)*. <https://doi.org/10.1007/s42979-021-00578-9>.
- Raju, J., Mohammed, S. S., Paul, J. V., et al. (2018). Development and implementation of Arduino microcontroller based dual mode fire extinguishing robot. In *2017 IEEE International Conference on Intelligent Techniques in Control, Optimization and Signal Processing (INCOS)*. <https://doi.org/10.1109/ITCOSP.2017.8303141>.
- Santis, A. D., Siciliano, B., Villani, L. (2006). Fuzzy Trajectory Planning and Redundancy Resolution for a Fire Fighting Robot. In *IEEE International Conference on Robotics & Automatonlike, 2006*. <https://doi.org/10.1109/ROBOT.2005.1570163>.
- Tavera, M. J. M., Lingerie, O., Dutra, M. S. (2011). Comparative study for chaotic behaviour in firefighting robot. *Revista Facultad de Internarial, 53(60), 31-41*. <https://doi.org/10.1002/maco.200905589>.
- Vivekanadan, S., Santhosh, G., Kuma, S. J., et al. (2016). A Novel Camera Based Mobile Robot With Obstacle Avoidance And Fire Extinguish Control. *International Journal of Engineering Research and Applications*.
- Zhang, K., Qu, T., Zhang, Y., Zhong, R. Y., Huang, G. (2022). Big data-enabled intelligent synchronisation for the complex production logistics system under the opti-state control strategy. *International Journal of Production Research, 60(13), 4159-4175*. <https://doi.org/10.1080/00207543.2021.2000657>.
- Zhang, K., Qu, T., Zhang, Y. H., Zhong, R. Y., Huang, G. (2021). Big data-enabled intelligent synchronisation for the complex production logistics system under the opti-state control strategy. *International Journal of Production Research, 60(13), 4159-4175*. <https://doi.org/10.1080/00207543.2021.2000657>.
- Zhou, Y., Wilkins, D., Cook, R. P. (1998). Neural network control for a fire-fighting robot. *Software Concepts and Tools, 19(3), 146-152*. <https://doi.org/10.1007/s003780050018>.

## Development of an AI-Based Alert System for Targeted Temperature Management Patients Using Machine Learning and Millimeter-Wave Technology

Chia-Lun Lo<sup>1,\*</sup>  
Tsung-Lung Yang<sup>2</sup>

\*Corresponding author

<sup>1</sup> Associate Professor, Fooyin University, Kaohsiung City, Taiwan, allenlo.tw@gmail.com

<sup>2</sup> Director, Kaohsiung Veterans General Hospital, Kaohsiung City, Taiwan, tlyang@vghks.gov.tw

### ABSTRACT

Targeted Temperature Management (TTM) is an emerging clinical technology designed to regulate the body temperature of post-cardiac arrest patients within the range of 32°C–34°C. This precise temperature control aims to reduce cerebral oxygen metabolism, thus stabilizing the medical condition of these patients. In the context of the COVID-19 pandemic, the importance of contactless healthcare and automated systems has grown significantly. This study leverages millimeter wave technology, a non-invasive approach, to gather comprehensive physiological data from patients, providing valuable insights into their overall health status. Beyond developing a predictive model for assessing TTM effectiveness, this research rigorously evaluates the data collection capabilities of millimeter wave technology, shedding light on its potential contributions to modern healthcare.

*Keywords:* Targeted temperature management, Millimeter wave technology, Machine learning, Cardiac arrest.

### INTRODUCTION

Sudden cardiac arrest is a global public health issue. Cardiac arrest can be divided into out-of-hospital cardiac arrest (OHCA) and in-hospital cardiac arrest (IHCA) based on the location it occurs. According to relevant medical research statistics, the survival rate of patients with OHCA is merely 1.4% – 7.2%; even when emergency treatment is provided in time, mortality rate can still be as high as 30% – 50% (Chang & Lin, 2005). The risk factors of OHCA include being male and aged 60 years or above, being under great financial stress, having diabetes, having a history of cardiovascular diseases or arrhythmias, and being on kidney dialysis (Chen & Wang, 2017).

According to Bernard (2002), lowering the body temperature of patients with cardiac arrest by 1°C can reduce their cerebral oxygen metabolism rate by 6%–8%. For patients with OHCA who are still in comas after emergency treatment, implementing TTM within a few hours to maintain their body temperatures at 32°C–34°C can continuously improve their prognoses and the probability that they reawaken. Holzer (2010) reported that implementing TTM can increase patients' survival rates from 30%–50% to 50%–70% and improve their neurological functions from 15%–25% to 25%–35%. The American Heart Association (AHA) has added TTM to its guidelines in 2015, advocating that applying TTM for more than 24 h enhances patients' survival rates (Callaway, et. al., 2015).

However, Dumas (2011) contended that TTM cannot effectively restore the consciousness of patients with pulseless electrical activity (PEA) or noncardiogenic cardiac arrest. Scales (2017) compared the differences between patients who received TTM and those who received other supportive care during the first six hours after their cardiac arrest, and found no significant increase in the survival rate of the TTM group and no statistically significant improvements in neurological functions. Zhang (2015) also noted that mild hypothermia did not improve the in-hospital and 6-month mortality results of adult patients with cardiac arrest.

In general, TTM requires relevant equipment to be installed and patients' physiological statuses to be monitored for 24–72 h. Previously, body temperature was measured via an invasive method (i.e., esophageal temperature monitoring), which required the medical staff to monitor every 0.25 unit of temperature change and ensure that a patient does not have fever and subtle changes in physiological signs during the 72 hours after their temperature returned to normal (Arrich J, 2007). Because contact with patients and the use of invasive equipment can increase the risks of infection, after the outbreak of COVID-19, contactless healthcare and automatic warning control systems have become increasingly crucial. According to recommendations made by existing studies and American Heart Association guidelines, this study collected the influencing factors of the temperature cooling period, maintained period, and rewarming period on the prognosis of patients receiving TTM to build a model for effective prognosis prediction. Additionally, this study used millimeter wave technology to collect patients' physiological parameters, such as breathing rate, heart rate, breathing status, body temperature, activity pattern, and blood pressure, to develop an artificial intelligence-based physiological analysis and early warning system. The system can alert medical staff of patients' medical conditions (i.e., degrees of improvement or deterioration) in advance, enabling the staff to intervene in a timely manner.

Such a noninvasive system eliminates the risks of infection and radiation exposure, and may be used as a tool for evaluating the practicality of remote health care.

## LITERATURE REVIEW

### 2.1 Targeted Temperature Management

Cardiac Arrest is defined as "a sudden loss of heart function that can be restored with appropriate therapy, but in the absence of appropriate treatment, can result in death"; nevertheless, if the time and method of occurrence are unpredictable, the condition is referred to as "Sudden Cardiac Arrest." While men account for approximately 60% of cardiac arrest cases, survival rates are higher in men compared to that of women, with no significant difference in neurological survival rates for discharge from hospital (Brady et al., 2011); while for out-of-hospital cardiac arrests (OHCAs), patients seen and cared for have a better neurological profile, with a 96% survival rate at one year for those with a better neurological prognosis (CPC=1 or 2), but a significantly higher mortality rate at one year for CPC=3 or 4 (Corrada et al., 2013). Infrequently discussed in the literature is the prevalence of in-hospital cardiac arrests (IHCA), and while the Utstein style guidelines suggest that the older a patient is, the lower his or her likelihood of being discharged alive, while no effect of gender on survival has been demonstrated (Schwenzer et al., 1993; Cummins, et al., 1997; Booth C.M., 2004; Mcmanus et al., 2012).

According to Nielsen (2013), patients with a target temperature setting lower than 34 degrees experienced more favorable prognosis outcomes compared to those who did not receive Targeted Temperature Management (TTM) therapy (Nielsen N et al., 2013). Typically, the important determinant of temperature reduction is the patient's body surface area, with patients of larger dimensions experiencing greater difficulty in achieving therapeutic effects, while patients of lighter weight or older age are more likely to achieve temperature reduction effects (Maier, C.M., et al., 2002; Nielsen N et al., 2011; Lyden P et al., 2012).

TTM consists of three phases: (a) Cooling phase: Patients with return of spontaneous circulation (ROSC) following cardiac arrest experience a rapid temperature reduction to 32-34°C within 3 hours, sustained over 24 hours. During this period, patients are prone to hypovolemia, electrolyte imbalance and hyperglycemia. A further extension of six hours in this phase has demonstrated to have a neuroprotective effect. (b) Maintenance phase: With temperature maintained at 33°C for an additional 24 hours; during this period, the patient is prone to shivering, immune deficiency, and pressure sores. (c) Recovery phase: During this period, if patients experience a stable physiological condition, temperature recovery is controlled at 0.2~0.5 degree Celsius per hour, ramping up slowly to the standard 37 degree Celsius. During this phase, patients are prone to electrolyte imbalance and hypoglycemic symptoms. The use of neuromuscular blocking drugs (Cisatracurium) during recovery of normal body temperature restoration necessitates discontinuation, and the patient should be in a sedated state until the temperature reaches 36°C. Upon recovery of body temperature, sedative drugs should be adjusted or administered as appropriate to the patient's condition (Shlee S. S., et al., 2012). Although the American Heart Association recommends that target temperature management be maintained for at least 24 hours, a study conducted in European hospitals found that extending the temperature to 48 hours did not increase survival over 24 hours, but side effects increased over time, resulting in prolonged ICU stays (Callaway CW, et al, 2015).

Currently, the use of TTM is associated with a risk of complications, with poor outcome factors including advanced age, chronic renal failure and abnormal left ventricular function (EF<30) (Laish-Farkash A et al., 2007). Several studies have shown a significant positive association between an age <75 years, prompt witnessing and resuscitation of the patient at the time of collapse and a return of spontaneous circulation (ROSC) index <40 minutes and a favorable prognosis (Peberdy MA et al., 2010; Perman SM et al., 2015). It is recommended in the AHA guidelines that continuous monitoring of brain wave variations is necessary when performing TTM for prevention of seizures with neuromuscular blocking agents, whereas continuous monitoring of brain waves is the only way to detect epilepsy (Polderman KH, Herold, 2009); while monitoring changes in electrolyte potassium and magnesium ions can prevent the risk of arrhythmias. In the case of further hemorrhage during the implementation of target temperature management, rapid rewarming, and rapid hemostasis and transfusion are necessary to reduce subsequent brain damage so as to minimize the complications caused by hypothermia and avoid more severe injuries. Thus, it is essential to monitor the patient's vitals at all times.

A majority of hospitals utilize Rapid Response Teams (RRTs) to prevent and manage patients in the event of an unexpected deterioration of their condition to avoid serious adverse events. In general, RRTs aim to identify and manage patient emergencies before the team is mobilized, so as to reduce nighttime staffing and workload, achieve staff consensus on patient care, reduce stress, reduce medical disputes, and improve quality of care, all of which can lead to improved patient prognosis (Maharaj et al., 2015; Solomon, et al., 2016). Furthermore, it has been demonstrated that RRT is effective in reducing cardiopulmonary arrest and hospital mortality outside the intensive care unit (Schneider, et al, 2013; Joonas et al., 2018). RRT attention can be distinguished into two, the Afferent arm and Efferent arm, in which the Afferent arm highlights its ability to "timely" detect signs of clinical deterioration and "efficiently" mobilize the team to avoid delays; while Early Warning Systems (EWS) are often employed in clinical settings to assess, predict, and select responses to detect and prevent emergencies. As patients undergoing TTM are all patients previously experiencing OHCAs, in order to avoid IHCA during TTM monitoring, immediate notification of patient risk is necessary for immediate emergency intervention. To address the challenges of delayed recording and alerting, wireless monitoring technologies provide continuous data, enabling more timely and less labor-intensive early warning monitoring, while reducing the risk of frequent direct contact resulting in infections, thus can serve as the standard for effective next generation alerting systems.

## 2.2 Millimeter-Wave Radar Technology

Millimeter-wave radar utilizes high-frequency millimeter-wave electromagnetic waves, typically ranging from 30 GHz to 300 GHz, to achieve high-resolution target detection and imaging in various environments. When explaining the principles of mmWave radar technology, the following equations and professional concepts contribute to a deeper understanding :

Millimeter-wave radar are operating in a high frequency, millimeter-wave radar exhibits relatively short wavelengths, showcasing strong line-of-sight properties, while also being affected by scattering and absorption caused by obstacles. The relationship between wavelength  $\lambda$  and frequency  $f$  can be represented using the wave speed  $c$  :

$$c = f \cdot \lambda \quad (1)$$

Where wave speed  $c \approx 3 * 10^8$  m/s corresponds to the speed of light

During propagation, millimeter-wave radar encounters path loss, which is the phenomenon of signal weakening as propagation distance increases. Pass loss  $L_p$  can be calculated using the following equation:

$$L_p = 20 \cdot \log_{10} \left( \frac{4\pi d}{\lambda} \right) \quad (2)$$

Where  $d$  represents propagation distance, and  $\lambda$  is wavelength. Additionally, free-space propagation loss  $L$  can be expressed as :

$$L = 20 \cdot \log_{10}(d) + 20 \cdot \log_{10}(f) + 20 \cdot \log_{10} \left( \frac{4\pi}{c} \right) \quad (3)$$

Millimeter-wave radar achieves target detection and imaging by emitting electromagnetic waves and receiving their reflected signals. The strength of the reflected signal is influenced by factors such as target's scattering cross-section, angle, and distance. The reflection coefficient  $T$  describe electromagnetic wave reflection at interfaces and is related to characteristic impedance  $Z$  and free-space impedance  $Z_0$ :

$$T = \frac{Z - Z_0}{Z + Z_0} \quad (4)$$

The transmission coefficient  $T$  can be calculated from the reflection coefficient:

$$T = 1 + R \quad (5)$$

Millimeter-wave radar finds widespread applications in fields such as automotive safety, human detection, and unmanned aerial vehicle navigation. However, challenges persist due to influences like rain, snow, fog, obstacles, and limitations in propagation distance, necessitating continuous engineering and algorithm optimization for mmWave radar technology. In summary, millimeter-wave radar technology leverages high-frequency electromagnetic waves to achieve high-resolution target detection and imaging. Its principles encompass critical concepts including frequency, wavelength, path loss, signal detection, and reflection. Despite challenges, millimeter-wave radar technology holds significant potential across various application domains.

When it comes to the application of millimeter-wave radar technology in the healthcare field, it is significant in non-invasive monitoring, imaging, and diagnostics. First of all, millimeter-wave radar can be employed for respiratory monitoring without the need for direct contact with the patient. When a person breathes, the chest undergoes subtle movements that alter the phase and amplitude of millimeter-wave signals. By measuring these minute changes, information about the respiratory rate and depth can be obtained. Besides, Millimeter-wave radar can penetrate the skin's surface layers to capture the characteristics of underlying tissues. Analyzing the scattering and absorption of signals allows for imaging of subcutaneous tissues such as fat, muscles, and blood vessels. This is particularly useful for the early diagnosis and treatment of skin lesions. Moreover, millimeter-wave radar can be used for early screening of breast cancer. Abnormal changes in breast tissue lead to alterations in the reflection and absorption of millimeter-wave signals. By comparing a patient's signals with baselines from normal tissue, potential abnormal areas can be detected, aiding in early diagnosis. Millimeter-wave radar also can offer insights into brain activity through skull imaging. Due to the propagation characteristics of millimeter waves through the skull, it is possible to non-invasively gather certain brain features, such as blood flow, contributing supplementary information to the diagnosis of brain disorders.

To sum up, the application of millimeter-wave radar technology in healthcare goes beyond conventional imaging methods, extending into non-invasive monitoring and early diagnostics. Its principles involve concepts such as slight signal variations, tissue characteristics, and anomaly detection. Despite the need to overcome technological and clinical challenges, the prospects of millimeter-wave radar in healthcare are promising, offering new possibilities for enhanced healthcare solutions.

## METHODS

This study comprises of two stages. The first stage consists of the identification of significant factors affecting the prognosis of TTM patients utilizing retrospective data, followed by the collection of CPOE, CIS, NIS, referral forms, and emergency physio-

logical data from ambulances for cross-tabulation upon confirmation of TTM cases. Prior to data collection, patient privacy considerations were taken into account and de-identification processes were performed.

According to existing literature, 728 patients with OHCA were identified in the retrospective database of the case hospitals from 2017 to 2020, totaling 148 patients upon excluding for failure to achieve ROSC prior to arrival, automatic discharge and transfer, severe brain injury, and death 48 hours after admission, 141 patients upon excluding for IHCA, and 109 patients following exclusion based on TTM model of patient hospitals. Following a comparison of the 109 patients who underwent TTM with a total of 180 patients sampled for conventional supportive care by gender and age. Basic information of patients, emergency characteristics, time duration of cooling procedures, and emergency outcomes were collected. Age, sex, disease history, patient origin, use of AED, initial heart rhythm, defibrillation exposure, pre-arrival ROSC, CPR time, post-ROSC consciousness index, cooling implementation, co-morbidities, interventions, survival to discharge, and post-discharge consciousness status were identified as independent variables, while survival after TTM and supportive care were used as dependent variables for comparison model construction.

In the first stage, the study utilized the open-source software WEKA (Waikato Environment for Knowledge Analysis), jointly developed by scholars from the University of Waikato, New Zealand, Witten & Frank, written in JAVA. The study employed built-in classification algorithms within WEKA 3.6, including Decision Trees (C4.5), Random Forest (RF), Logistic Regression (LR), Support Vector Machine (SVM), and Multi-Layer Perceptron (MLP). These classifiers were used to construct predictive models for two groups of data: target temperature management and non-target temperature management. A 10-fold cross-validation method was used to validate the performance of the predictive models on both testing and training data sets, ensuring credibility by avoiding redundant data within each group and recording all experimental processes.

Performance evaluation was conducted by observing three indicators in the classifier's predictive models: Accuracy, Sensitivity, and Specificity. Classifier performance was primarily measured by Accuracy. However, as Accuracy assumes equal importance for all categories, it might exhibit bias when dealing with highly imbalanced classification scenarios. Thus, in binary classification problems, if a classifier can correctly classify actual target and non-target categories, it can be considered a good classifier. The confusion matrix calculates the proportion of actual categories predicted correctly, termed True Positive (TP) or Sensitivity, and the proportion of non-target categories predicted correctly, termed True Negative (TN) or Specificity. Accuracy refers to the correct prediction of actual categories.

In the second stage, we consist of testing the effectiveness of the wireless physiological alert system developed by the research team based on the impact factors established in the first stage. Forty subjects utilizing TTM in collaborating hospitals were enrolled in the experiment for automatic measurement of physiological signs via a zero-contact wireless motion sensor based on Millimeter Wave Technology developed by Wistron Medical Technology, featuring radar sensing technology that registers pulse and respiratory signals. Radar detection enables continuous monitoring of the patient's heart rate and respiration values and real-time cloud uploading independent of external light sources and circadian environment, eliminates the necessity of contact and wearing of device, thus minimizing disturbance to the user, and obviates privacy concerns owing to device non-video recording properties. For the control group, patient heart rate and respiratory values were continuously monitored and stored in a designated device for follow-up comparison using a general patient monitor with at least 3 Lead ECG modules affixed by the caregiver to the sides of the clavicle and below the rib cage respectively for the acquisition of cardiac and respiratory measurements. A comparison of the results of the two groups was then performed and consistency of the physiological measurements were tested. Lastly, TTM prediction models were constructed by integration of significant factors from the first stage and the physiological information collected from the wireless zero-contact device in the second stage by means of a data mining classification.

## RESULTS

Of the 109 TTM cases collected in the first stage, patients ranged from 18 to 92 years of age, with a mean age of 60.8, predominantly males (65.8%), with a history of hypertension (62.2%), diabetes mellitus (38.7%), and coronary artery disease (23.4%). 72.1% of patients experienced OHCA, 26.1% experienced IHCA, 50.5% received AED resuscitation. The majority of initial rhythms were VT/VF (56.8%), 35.1% of the patients experienced pre-arrival ROSC, the majority of patients had endotracheal tubes inserted for all verbal response (68.5%), followed by tracheotomy (28.8%), hypokalemia (48.6%) and infection (17.1%) were the most common complications in performing cooling procedures, and 7.2% were treated with ECMO, with a final survival rate of exactly 51%, with 24.3% having undergone coronary angiography.

In this study, Cox regression analysis as table 1, was further performed to analyze the relationship between duration and temperature of patients undergoing target temperature management and the independent variables established in this study. This study defines a 5-hour interval as an analysis interval. The experimental results from 199 samples show that there is a possibility of survival for cases only after approximately 20 hours of low-temperature treatment. Under a risk setting of 1/2, the number of individuals exposed to the risk is 188, and the number of terminal events, representing the number of survivors 20 hours later, is 5, resulting in a termination rate of 0.03 and a mortality rate of 0.97. The low-temperature treatment is maintained for about 72 hours (indicating  $t > 70$ ). The survival rate will only begin to significantly increase ( $>20\%$ ) after this period, with approximately 47 patients exposed. This implies a survival rate of 84% to 87%. From the perspective of risk rates, an increase begins after 40 hours and beyond 70 hours. This can be interpreted as follows: the effectiveness of targeted temperature management therapy is divided into two stages. First, within the initial 40 hours, the significant improvement of physiological signs can be assessed. If

improvement is observed, the evaluation can be extended to 70 hours. However, if there is no significant improvement within an appropriate time frame, prolonging the treatment duration would likely be in vain.

Results indicated that: 1. The younger the patient, the higher the probability of successful survival with targeted temperature management therapy. 2. Within patients with coronary artery diseases and cardiac arrhythmias, the longer the TTM time period, the higher the chance of survival. 3. Patients without chronic kidney disease have a higher probability of survival given a shorter TTM time period. 4. Patients who have experienced defibrillation have a better TTM efficacy. 5. Patients without de novo cardiac arrhythmia can achieve physiological stability with a shorter duration of TTM. However, if there is a new onset of epilepsy during the TTM process, TTM duration requires extension. The life cycle of the TTM treatment as Figure 1.

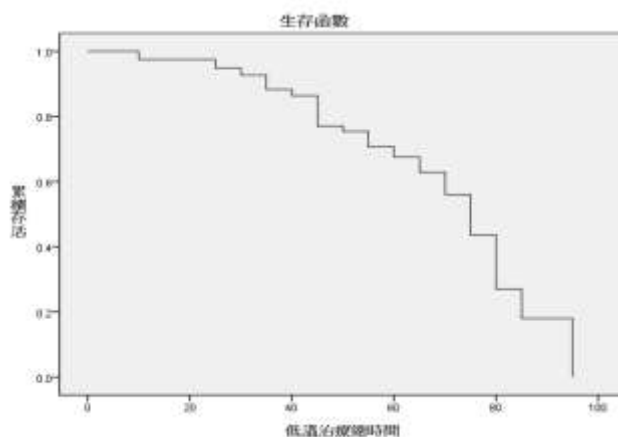

Figure 1 Life cycle of the TTM treatment

Table 1 the results of Cox analyses for TTM patients

Variables <sup>a)</sup>	B <sup>a)</sup>	SE <sup>a)</sup>	Wald <sup>a)</sup>	p <sup>a)</sup>	Exp(B) <sup>a)</sup>	
basic information <sup>a)</sup>	age <sup>a)</sup>	-.026 <sup>a)</sup>	.013 <sup>a)</sup>	4.017 <sup>a)</sup>	.045 <sup>a)</sup>	.974 <sup>a)</sup>
	diabetes <sup>a)</sup>	.451 <sup>a)</sup>	.411 <sup>a)</sup>	1.203 <sup>a)</sup>	.273 <sup>a)</sup>	1.570 <sup>a)</sup>
	hypertension <sup>a)</sup>	.416 <sup>a)</sup>	.335 <sup>a)</sup>	1.538 <sup>a)</sup>	.215 <sup>a)</sup>	1.516 <sup>a)</sup>
	coronary heart disease <sup>a)</sup>	.749 <sup>a)</sup>	.367 <sup>a)</sup>	4.170 <sup>a)</sup>	.041 <sup>a)</sup>	2.116 <sup>a)</sup>
	congestive heart failure <sup>a)</sup>	-.432 <sup>a)</sup>	.532 <sup>a)</sup>	.660 <sup>a)</sup>	.417 <sup>a)</sup>	.649 <sup>a)</sup>
	irregular heart rhythm <sup>a)</sup>	3.750 <sup>a)</sup>	1.334 <sup>a)</sup>	7.901 <sup>a)</sup>	.005 <sup>a)</sup>	42.540 <sup>a)</sup>
	COPD or asthma <sup>a)</sup>	.933 <sup>a)</sup>	.679 <sup>a)</sup>	1.887 <sup>a)</sup>	.170 <sup>a)</sup>	2.542 <sup>a)</sup>
	chronic kidney disease <sup>a)</sup>	-1.727 <sup>a)</sup>	.410 <sup>a)</sup>	17.756 <sup>a)</sup>	.000 <sup>a)</sup>	.178 <sup>a)</sup>
	end-stage renal disease <sup>a)</sup>	.412 <sup>a)</sup>	.504 <sup>a)</sup>	.668 <sup>a)</sup>	.414 <sup>a)</sup>	1.510 <sup>a)</sup>
	cirrhosis <sup>a)</sup>	.079 <sup>a)</sup>	.558 <sup>a)</sup>	.020 <sup>a)</sup>	.887 <sup>a)</sup>	1.083 <sup>a)</sup>
	stroke <sup>a)</sup>	-.947 <sup>a)</sup>	.611 <sup>a)</sup>	2.398 <sup>a)</sup>	.121 <sup>a)</sup>	.388 <sup>a)</sup>
	Hyperlipidemia <sup>a)</sup>	.172 <sup>a)</sup>	.451 <sup>a)</sup>	.146 <sup>a)</sup>	.703 <sup>a)</sup>	1.188 <sup>a)</sup>
	tumor <sup>a)</sup>	-.227 <sup>a)</sup>	.388 <sup>a)</sup>	.343 <sup>a)</sup>	.558 <sup>a)</sup>	.797 <sup>a)</sup>
	Patient source (IHCA, OHCA) <sup>a)</sup>	.115 <sup>a)</sup>	.355 <sup>a)</sup>	.104 <sup>a)</sup>	.747 <sup>a)</sup>	1.121 <sup>a)</sup>
ER Features <sup>a)</sup>	AED <sup>a)</sup>	.244 <sup>a)</sup>	.409 <sup>a)</sup>	.355 <sup>a)</sup>	.551 <sup>a)</sup>	1.276 <sup>a)</sup>
	initial heart rhythm <sup>a)</sup>	-.299 <sup>a)</sup>	.765 <sup>a)</sup>	.153 <sup>a)</sup>	.696 <sup>a)</sup>	.742 <sup>a)</sup>
	electric shock <sup>a)</sup>	-1.070 <sup>a)</sup>	.457 <sup>a)</sup>	5.489 <sup>a)</sup>	.019 <sup>a)</sup>	.343 <sup>a)</sup>
	ROSC before arrival <sup>a)</sup>	-.194 <sup>a)</sup>	.366 <sup>a)</sup>	.279 <sup>a)</sup>	.597 <sup>a)</sup>	.824 <sup>a)</sup>
Comorbidities <sup>a)</sup>	new bleeding <sup>a)</sup>	-.921 <sup>a)</sup>	.597 <sup>a)</sup>	2.379 <sup>a)</sup>	.123 <sup>a)</sup>	.398 <sup>a)</sup>
	new onset arrhythmia <sup>a)</sup>	-1.299 <sup>a)</sup>	.466 <sup>a)</sup>	7.783 <sup>a)</sup>	.005 <sup>a)</sup>	.273 <sup>a)</sup>
	new serious infection <sup>a)</sup>	-.038 <sup>a)</sup>	.394 <sup>a)</sup>	.009 <sup>a)</sup>	.923 <sup>a)</sup>	.963 <sup>a)</sup>
	new-onset epilepsy <sup>a)</sup>	.922 <sup>a)</sup>	.500 <sup>a)</sup>	3.406 <sup>a)</sup>	.065 <sup>a)</sup>	2.515 <sup>a)</sup>
Treatment <sup>a)</sup>	Hypokalemia <sup>a)</sup>	-.056 <sup>a)</sup>	.377 <sup>a)</sup>	.022 <sup>a)</sup>	.882 <sup>a)</sup>	.945 <sup>a)</sup>
	Hypoglycemia <sup>a)</sup>	.149 <sup>a)</sup>	.543 <sup>a)</sup>	.075 <sup>a)</sup>	.783 <sup>a)</sup>	1.161 <sup>a)</sup>
	ECMO <sup>a)</sup>	.504 <sup>a)</sup>	.508 <sup>a)</sup>	.985 <sup>a)</sup>	.321 <sup>a)</sup>	1.655 <sup>a)</sup>
	Coronaryangiography <sup>a)</sup>	-.137 <sup>a)</sup>	.479 <sup>a)</sup>	.082 <sup>a)</sup>	.775 <sup>a)</sup>	.872 <sup>a)</sup>
	PCL <sup>a)</sup>	.600 <sup>a)</sup>	.437 <sup>a)</sup>	1.887 <sup>a)</sup>	.170 <sup>a)</sup>	1.822 <sup>a)</sup>

For the experiments of the second stage of this study, results were compared between patients monitored with conventional general patient monitors and patients monitored with millimeter wave technology-based wireless zero-contact automatic physiological data collection and transmission systems, with data processing steps as follows: 1. MP20 and radar time were first aligned, 2. data was collected mainly during stable rest, 3. data during activity and respiratory arrest was removed, followed by analysis of the results of MP20 and millimeter wave radar devices. Results of the analysis indicated a mean heart rate of 76.05

bpm, a median of 76.00 bpm, and a standard deviation of 10.61; a mean respiratory rate of 18.60 rpm, a median of 18.00 rpm, and a standard deviation of 4.12. The results of regression analysis demonstrated that the R2 for the MP20 and radar wave comparisons was 0.998 for heart rate and 0.9929 for res-piratory rate; the mean absolute error (MAE) of heartbeat value was 1.96 bpm and the MAE of respiration value was 1.32 rpm, which suggested a high positive correlation between the heartbeat and respiration values of the two devices. In addition, according to the results of Bland-Altman analysis, the measurement discrepancies between the two devices were within the 95% limits of agreement (95% LoA), with error range of heartbeat values within +6.48 to -7.07 and an average absolute deviation of -0.3; error range of respiration values within +3.66 to -3.85 and an average absolute deviation of -0.09. According to these results, it can be considered that the measurement of these two devices are consistent and reliable.

Based on the above experimental results, we then adopted the significant factors established in the first stage and the bestshape VS AI system developed by Wistron Medical Technology in the second stage to collect physiological data from cases in a zero-contact manner. We adopted five well-known classification algorithms (including C4.5, SVM, classical neural network, and random forest) to construct a predictive model, which was validated for regarding validity against a 10-fold cross-validation on a test set and a training set. The results of the experiments were shown as figure 2, which indicated that a random forest-based predictive model was the optimal classification method for further development of classification and early warning systems binding in the healthcare information system in the case hospital.

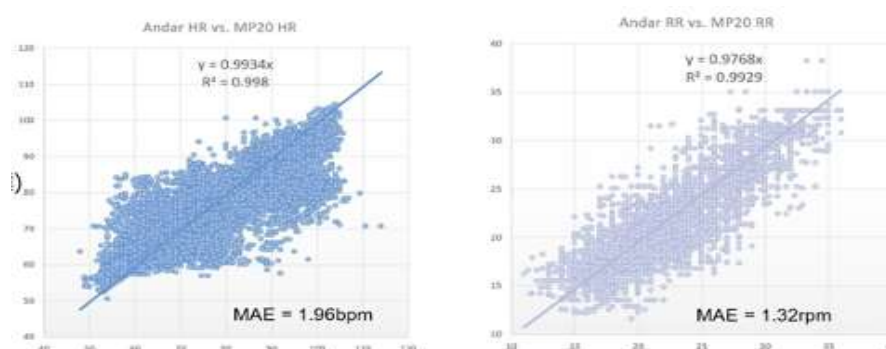

Figure 2 Compare results between MP20 and Millimeter wave technology radar

Table 2 Experiment results of the classifiers for TTM models

Technique	Sensitivity	Specificity	AUC	Accuracy
J48	0.78	0.57	0.73	0.71
RF	0.82	0.75	0.88	0.80
SMO	0.84	0.69	0.76	0.79
LR	0.83	0.74	0.81	0.81
MLP	0.82	0.67	0.78	0.77

## CONCLUSION

In recent years, there has been an increasing trend in patients experiencing sudden cardiac arrests, leading to unforeseen family stress. On the other hand, advancements in medical technology have improved survival chances, yet they have also raised questions about resource allocation. With the gradual maturation of artificial intelligence and machine learning, utilizing retrospective data and analytical tools to acquire more accurate predictive factors for care outcomes proves highly beneficial for clinical decision-making. This study presents a preliminary model for predicting the time required for target temperature management treatment in clinical cardiac arrest patients. This achievement serves as a significant advancement for patients, physicians, and medical personnel alike. It not only offers reference for treatment decisions related to cardiac arrests but also helps manage patients' excessive expectations regarding the success rate of target temperature management, thereby reducing feelings of disappointment.

In this two-stage of this study, we identified significant factors for the prognostic effectiveness of TTM and demonstrated the feasibility of wireless monitoring technology prior to the construction of a random forest-based early warning system. For caregivers of TTM patients, wireless monitoring technology facilitates the provision of 24-hour continuous monitoring, which allows for more timely early warning monitoring and real-time alerts to be sent to caregivers' handheld devices enabling them to keep track of changes in patients' medical status on-the-go, without the need for additional labor-intensive manual measurements and transcription processes. In terms of pandemic prevention mechanism, wireless monitoring technology provides safer clinical care by minimizing human contact. However, as TTM is implemented on non-common cases among patients and the study is



conducted in a single hospital, there are limitations in sample size and data collection, therefore, it is suggested that future studies can expand the target of sample collection to compare hospital level and regional differences. Furthermore, to ensure the accuracy and credibility of the experimental results, brain wave monitoring may be incorporated to further enable more accurate prediction of neurological conditions, whereas the duration of the study should be extended to observe the degree of neurological recovery and the level of post-therapy care. Lastly, a clinical decision-making support system may be integrated to translate examination and consultation-related data into valuable decision-making information, enabling physicians or decision makers to more accurately assess patient co-morbidities and status at each stage utilizing the predictive model.

#### ACKNOWLEDGMENT

This research was partially supported in part by the Ministry of Science and Technology of Taiwan under grant numbers MOST 110-2410-H-242 -001 -MY2 & 112-2410-H-242 -002. The Millimeter wave technology device was supported from Wistron Medical Technology Company. And experimental procedure and TTM cases were supported from Kaohsiung Veterans General Hospital, Kaohsiung, Taiwan.

#### REFERENCES

- Arrich, J. (2007). Clinical application of mild therapeutic hypothermia after cardiac arrest. *Critical Care Medicine*, 35, 1041-1047.
- Booth, C. M., Boone, R. H., Tomlinson, G., et al. (2004). Is this patient dead, Vegetative, or severely neurologically impaired? Assessing outcome for comatose survivors of cardiac arrest. *Journal of the American Medical Association*, 291, 870-879.
- Bernard, S. A., Gray, T. W., Buist, M. D., et al. Treatment of comatose survivors of out-of-hospital cardiac arrest with induced hypothermia. *New England Journal Medicine*, 346, 557-563.
- Brady, W. J., Gurka, K. K., Mehring, B., Peberdy, M. A., and O'Connor, R. E. (2001). In-hospital cardiac arrest: impact of monitoring and witnessed event on patient survival and neurologic status at hospital discharge. *Resuscitation Journal*, 82(7), 845-852.
- Callaway, C. W., Donnino, M. W., Fink, E. L., Geocadin, G., Golan, E., Kern, K. B., et al. (2015). Post Cardiac Arrest Care. *American Heart Association Guidelines Update for Cardiopulmonary Resuscitation and Emergency Cardiovascular Care. Circulation*, 132, S465-482.
- Chang, M. Y., & Lin, M. (2005). Predictors of survival and hospital outcome of prehospital cardiac arrest in southern Taiwan. *Journal of the Formosan Medical Association*, 104, 639-646.
- Chen, D. L., & Wang G. J. (2017). Adult Out-of-Hospital Cardiac Arrest: Cause, Mechanism, Management and Prevention. *Adaptive Medicine*, 9(3), 125-129.
- Corrada, E., Mennuni, M. G., Grieco, N., Sesana, G., Beretta, G., & Presbitero, P. (2013). Neurological recovery after out-of-hospital cardiac arrest: hospital admission predictors and one-year survival in an urban cardiac network experience. *Minerva Cardioangiologica*, 61(4), 451-460.
- Cummins, R. O., Chamberlain, D., Hazinski, M. F., et al. (1997). Recommended guidelines for reviewing, reporting, and conducting research on in-hospital resuscitation: the in-hospital 'Utstein style'. *Resuscitation Journal*, 34(2), 151-183.
- Dumas, F., Grimaldi, D., Zuber, B., et al. (2001). Is hypothermia after cardiac arrest effective in both shockable and nonshockable patients? insights from a large registry. *Circulation Journal*, 123, 877-886.
- Holzer, M. (2010). Targeted temperature management for comatose survivors of cardiac arrest. *New England Journal Medicine*, 363, 1256-1264.
- Joonas, T., Heini, H., Sanna, H. (2018). In-hospital cardiac arrest after a rapid response team review: A matched case-control study. *Resuscitation*, 126(1), 98-103.
- Laish-Farkash, A., Matetzky, S., Kassem, S., et al. (2007). Therapeutic hypothermia for comatose survivors after cardiac arrest. *Israel Medical Association Journal*, 9, 252-256.
- Lyden, P., Ernstrom, K., Cruz-Flores, S., Gomes, J., Grotta, J., Mullin, A., Rapp, K., Raman, R., Wijman, C., Hemmen, T. (2012). Determinants of effective cooling during endovascular hypothermia. *Neurocritical care*, 16, 413-420.
- Maier, C. M., Sun, G. H., Cheng, D., Yenari, M. A., Chan, P. H., Steinberg, G. K. (2002). Effects of mild hypothermia on superoxide anion production, superoxide dismutase expression, and activity following transient focal cerebral ischemia. *Neurobiology of disease*, 11, 28-42.
- Maharaj, R., Raffaele, I., Wendon, J. (2015). Rapid response systems: a systematic review and meta-analysis. *Critical Care*, 19(1), 254.
- McManus, D. D., Aslam, F., Goyal, P., Goldberg, R. J., Huang, W., and Gore, J. M. (2012). Incidence, prognosis, and factors associated with cardiac arrest in patients hospitalized with acute coronary syndromes. the Global Registry of Acute Coronary Events Registry. *Coronary Artery Disease*, 23(2), 105-112.
- Nielsen, N., Friberg, H., Gluud, C., Herlitz, J., Wetterslev, J. (2011). Hypothermia after cardiac arrest should be further evaluated. A systematic review of randomised trials with meta-analysis and trial sequential analysis. *International Journal of Cardiology*, 151, 333-341.
- Nielsen, N., Wetterslev, J., Cronberg, T., Erlinge, D., Gasche, Y., Hassager, C., et al. (2013). Targeted temperature management at 33 degrees C versus 36 degrees C after cardiac arrest. *New England Journal of Medicine*, 369, 2197-2206.
- Perman, S. M., Grossestreuer, A. V., Wiebe, D. J., et al. (2015). The utility of therapeutic hypothermia for post-cardiac arrest syndrome patients with an initial non-shockable rhythm. *Circulation Journal*, 132, 2146-2151.
- Peberdy, M. A., Callaway, C. W., Neumar, R. W., et al. (2010). American Heart Association Guidelines for Cardiopulmonary Resuscitation and Emergency Cardiovascular Care. *Circulation*, 122, S768-86.

- Polderman, K. H., & Herold, I. (2009). Therapeutic hypothermia and controlled normothermia in the intensive care unit: practical considerations, side effects, and cooling methods. *Critical Care Med*, 37(3), 1101–1120.
- Scales, D. C., Cheskes, S., Verbeek, P. R., Pinto, R., Austin, D., Brooks, S. C., Dainty, K. N., Goncharenko, K., Mamdani, M., Thorpe, K. E., Morrison, L. J. (2017). Prehospital cooling to improve successful targeted temperature management after cardiac arrest: A randomized controlled trial. *Resuscitation Journal*, 121, 187-194.
- Schwenzer, K. J., Smith, W. T., Durbin, C. G. Jr. (1993). Selective application of cardiopulmonary resuscitation improves survival rates. *Anesthesia & Analgesia*, 76, 478–484.
- Schneider, A. G., Warrilow, S., Robbines, R., Jones, D. A., Bellomo, R. (2013). An assessment of the triage performance of the efferent arm of the rapid response system. *Resuscitation*, 84(1), 477-482.
- Song, S. S., & Lyden, P. D. (2012). Overview of therapeutic hypothermia. *Current Treatment Options in Neurology*, 14(6), 541-548.
- Soloman, R. S., Corwin, G. S., Barclay, D. C., Quddusi, S. F., Dannenberg, M. D. (2016). Effectiveness of rapid response teams on rates of in-hospital cardiopulmonary arrest and mortality: a systematic review and meta-analysis. *Journal of Hospital Medicine*, 11(6), 435-445.
- Zhang, X. W. (2015). The effect of mild induced hypothermia on outcomes of patients after cardiac arrest: a systematic review and meta-analysis of randomized controlled trials. *Critical Care*, 19, 1-17.

## **Development of Bayesian Network-Based Regional Healthcare Analysis Model for Data-Driven Approach**

Miyako Kawashima <sup>1</sup>  
Haruka Ohba <sup>2</sup>  
Shinya Mizuno <sup>3,\*</sup>

---

\*Corresponding author

<sup>1</sup> Master's Student, Juntendo University, Tokyo, Japan

<sup>2</sup> Researcher, Shizuoka Institute of Science and Technology, Shizuoka, Japan, ohba.haruka@sist.ac.jp

<sup>3</sup> Professor, Juntendo University, Chiba, Japan, s.mizuno.kc@juntendo.ac.jp

### **ABSTRACT**

In many countries worldwide, especially in Japan, Germany, and Italy, there is an ongoing trend of an aging population. With this comes the enhancement and effective use of health data. While many nations are engaging in health data initiatives, particularly the organization and utilization of clinical information, there are numerous challenges in the actual utilization of the data. Bayesian networks have been gaining traction in various research fields, with their applications in the medical sector drawing significant attention. In this study, we utilized Bayesian networks to tackle regional medical challenges by leveraging data that integrates medical care, nursing, and health services. Using the American open data NHANES, we constructed and evaluated a Bayesian network, demonstrating the utility of networks developed through feature selection in general model construction.

*Keywords:* Bayesian Networks, Data-Driven Approach, Regional Healthcare Analysis, Open Data.

### **INTRODUCTION**

Aging populations have become a significant challenge in many countries worldwide, including Japan, Germany, and Italy. In Japan, the population aged 65 and above has reached 36.21 million, accounting for 28.9% of the total population, marking the country's entry into a super-aged society (Cabinet Office Japan, 2022). Consequently, Japan is advancing the organization and utilization of health data. However, the actual handling of this data, such as data integration and analysis, poses a substantial burden on local governments.

Globally, many countries are undertaking health data initiatives, especially in the areas of medical information organization and utilization, at the national level. However, many nations face challenges. In Japan, there's a desire to utilize health and medical data owned by local governments. The Ministry of Economy, Trade, and Industry has summarized its healthcare industry policies and made them publicly available on its website. This includes the need for a coordinated system in communities to seamlessly provide 1) awareness of health, 2) guidance to statutory medical check-ups, 3) consultations and advice from doctors based on the results, and 4) responsive actions based on risk levels, ranging from prevention to medical treatment. Additionally, as a part of the "Japan Revitalization Strategy", led by the Ministry of Health, Labour, and Welfare there is an emphasis on all health insurance unions to analyze data, such as receipts, and to devise and publish a "Data Health Plan" to promote members' health, implement business plans, and evaluate them. These plans are available on the websites of each municipality, but creating a data health plan requires securing personnel capable of data analysis and time. It is believed that the effectiveness of these data health plans must be measured in the future.

Regarding the medical, nursing, and health-related data owned by local governments, the primary sources are the National Health Insurance Database (hereafter, KDB) and survey results during health checkups owned by the municipalities (National Health Insurance Central Union., n.d.). The KDB system aggregates information from specific health checkups, health guidance, medical insurance, and nursing insurance that the National Health Insurance Group Union holds through various operations. Municipalities can utilize the aggregated information through an insurer's network. Broadly, the information handled in the KDB system falls into three categories: health checkups, medical care, and nursing care. Though the KDB has been available since fiscal year 2018, while it has been utilized for statistical information in the health domain, it hasn't yet been used to address on-ground challenges. Research is underway for the development of tools to support the National Health Insurance Data Health Plan, but it hasn't reached a point where a wide range of local governments can use it.

In this research, we construct a regional medical analysis model using Bayesian networks, aimed at a data-driven approach to address regional medical challenges by leveraging integrated data from medical, nursing, and health sectors. This study seeks to bridge the gap between the availability of extensive health and medical data and its practical utilization in addressing regional medical challenges. By employing a data-driven approach through Bayesian networks, our research not only enhances the

understanding of regional medical patterns but also pushes the boundaries of current literature in leveraging integrated health data for tangible on-ground improvements.

## RELATED WORK

The use of Bayesian networks is widely adopted across a diverse range of research fields, with an increasing trend in application examples and proposals for new algorithms. In this chapter, through international and Japanese literature, we summarize prior research from the perspectives of structural learning and algorithms of Bayesian networks, their applications across various domains, and their specific applications in the medical field.

### Perspective on Structural Learning and Algorithms of Bayesian Networks

Improving efficiency in the structural learning of Bayesian networks is a crucial theme among researchers. Di et al. (2022) have highlighted the limitations of the traditional depth-first search strategy and proposed a new search strategy based on dynamic programming. This research suggests that it is possible to quickly search for an optimal structure even in large-scale network structures, leading to a significant reduction in computational time. On the other hand, Ke et al. (2022) have addressed challenges related to the structural learning of Bayesian networks when there is missing data. They identified patterns and causes of missing data and developed effective learning methods based on these findings.

### Perspective on the Application of Bayesian Networks Across Various Fields

Chang et al. (2022) proposed a Bayesian network for anomaly detection in coal mill processes. This method allows for rapid early detection and identification of anomalies that occur during coal mill operations, contributing to improved safety in large-scale industrial processes. Liu, Zhou, and Sun (2022) conducted research on risk assessment of gasification furnace systems. Their proposed Bayesian network models various risk factors and their interactions in detail, achieving a more accurate risk assessment.

### Perspective on Applications in the Medical Field

Bayesian networks have seen numerous applications in the medical domain. Tummers et al. (2022) analyzed determinants of physical activity behavior change through online interventions using Bayesian networks. They elucidated how individual behaviors and psychological factors influence changes in physical activity, enabling the proposal of more effective online interventions. Igarashi et al. (2022) conducted a detailed analysis using Bayesian networks on the increase in medical costs for elderly patients with cognitive impairments experiencing delirium. They demonstrated that preventing delirium significantly contributes to reducing medical expenses, which can be useful in formulating medical policies. Sasaki et al. (2019) proposed a method to predict the onset of type 2 diabetes in regions using Bayesian networks. By considering the characteristics and risk factors of each area, it is possible to predict the risk of diabetes onset in detail. Miyauchi et al. (2016) proposed a method to uniformly handle multiple question items and different expressions within the framework of Bayesian networks using specific health checkup data. This research contributes to the integrated analysis of health checkup data with different data sources and question content. Toriumi et al. (2018) highlighted the effectiveness of Bayesian networks in formulating regional health policies and discussed the identification of causal relationships for specific policy improvements and the improvement of model explainability. However, on the other hand, Kyrimi et al. (2021) explored the factors that make Bayesian networks difficult to use in clinical settings. According to this, resistance from clinicians and a lack of model generalization are cited as reasons.

### Characteristics of this study

The following are the characteristics of this study based on previous studies.

- Utilization of Health and Medical Data  
This study addresses the issue that Japanese municipalities have not been actively utilizing health and medical data they own. By verifying with American open data, similar to Japan's KDB, this study examines the utilization of health and medical data owned by municipalities. These issues are related to the efficiency of Bayesian network structural learning and the handling of missing data, as pointed out in the studies by Di et al. (2022) and Ke et al. (2022).
- Building a Model that's Easy to Understand on the Ground  
For utilization in municipalities, there is a need to construct an analysis model that local staff can easily understand. In this study, we build a unique Bayesian network and evaluate a regional medical model. This is related to the model's explainability discussed in the study by Toriumi et al. (2018) and the efforts to unify question items and expressions within the framework of the Bayesian network proposed in the study by Miyauchi et al. (2016).
- Application of Bayesian Networks in the Medical Field  
Related to the above two points, Bayesian networks are currently utilized in the medical field focusing on specific diseases as topics. Our research model follows a continuous flow from attributes to test results and diagnosis, making it applicable for a wide range of disease prevention.

In the realm of medical informatics and information systems, the integration and practical application of health data remain an evolving domain. This research holds significance as it uniquely aligns medical informatics with the practical challenges faced by local municipalities. By constructing and evaluating a regional medical model, we underscore the transformative potential of information systems in healthcare. Our model, rooted in the principles of Bayesian networks, offers a structured yet adaptable framework, enabling municipalities to harness their health data more efficiently. Furthermore, by presenting a continuous flow

from attributes to test results and diagnoses, we introduce a versatile tool, adaptable across a myriad of diseases, demonstrating the expansive potential of information systems in reshaping healthcare strategies.

## MATERIALS AND METHODS

### Structure of Bayesian Networks

Let's represent the set of  $N$  nodes that constitute the Bayesian network as (Heckerman, 1995; Koller and Friedman, 2009):

$$V_N = \{X_1, X_2, \dots, X_N\} \quad (1)$$

$X_i$  is the node  $i \in \{1, 2, \dots, N\}$  in the Bayesian network. The adjacency matrix  $A$  between nodes is  $N \times N$ , and the element  $A_{ij}$  of  $A$  is defined as:

$$A_{ij} = \begin{cases} 0 & \text{if there is a directed edge from } X_i \text{ to } X_j, i, j \in \{1, 2, \dots, N\} \\ 1 & \text{otherwise} \end{cases} \quad (2)$$

The set of edges connecting these nodes is given by:

$$E = \{(X_i, X_j) | i, j \in \{1, 2, \dots, N\}, i \neq j, \text{ and } A_{ij} = 1\} \quad (3)$$

Forming a Directed Acyclic Graph (DAG)  $G$  from these, we have:

$$G = (V_N, E) \quad (4)$$

The set of parent nodes in the Bayesian network for node  $X_i$  is:

$$Parents_A(X_i) = \{X_j | A_{ji} = 1\} \quad (5)$$

The conditional probability distribution (CPD) is given by:

$$P(X_i | Parents_A(X_i)) = P(X_i | \{X_j | A_{ji} = 1\}) \quad (6)$$

From these definitions, the Bayesian network  $B$  can be represented as:

$$B = (V_N, E, CPD) \quad (7)$$

Furthermore, the parameters  $\theta$  when defining the conditional probability distribution (CPD) for node  $X_i$  are expressed as follows. Let the set of states that node  $X_i$  can take be  $S_i$ , and the set of state combinations of the parent nodes  $Parents_A(X_i)$  of node  $X_i$  be  $S_{Parents_A(X_i)}$ . In this case, the parameter  $\theta$  is defined by:

$$\theta_{ijk} = P(X_i = s_{ik} | Parents_A(X_i) = s_{ij}) \quad (8)$$

Where:

- $i$  is the index indicating node  $X_i$
- $j$  indicates a specific combination of states within  $S_{Parents_A(X_i)}$
- $k$  is an index indicating a specific state within  $S_i$  such that  $k \in \{1, 2, \dots, |S_i|\}$
- $s_{ik}$  indicates the  $k$ -th state within  $S_i$
- $s_{ij}$  represents the  $j$ -th state combination within  $S_{Parents_A(X_i)}$

Thus,  $\theta$  becomes a set of conditional probability values for all nodes  $X_i$  and each combination of states of their parent nodes within the network. The likelihood  $L$  represents the probability of the Bayesian network generating a given dataset  $D$  composed of  $M$  data points (constructed as  $d_1, d_2, \dots, d_M$ ), and is given by:

$$L(\theta; D) = \prod_{m=1}^M P(d_m | \theta) \quad (9)$$

Here, each data point  $d_m$  indicates a combination of values for each node, represented as  $(X_i = x_{1m}, X_2 = x_{2m}, \dots, X_N = x_{Nm})$ . The probability of each data point  $d_m$  is:

$$P(d_m | \theta) = \prod_{i=1}^N P(X_i = x_{im} | Parents_A(X_i) = x_{i, Parents_A(X_i)m}; \theta_{ijk}) \quad (10)$$

Where:

- $x_{im}$  is the value of node  $X_i$  in the data point  $d_m$
- $x_{i, Parents_A(X_i)m}$  represents the combination of the parent nodes  $Parents_A(X_i)$  for node  $X_i$  in data point  $d_m$
- $\theta_{ijk}$  indicates the parameters of the conditional probability distribution for node  $X_i$

### Evaluation of the Bayesian Network Model

The suitability of the given Bayesian network model is evaluated using the following procedure (Neapolitan, 2004):

- (1) Provide the Bayesian Network Structure:

For each node  $X_n$ ,  $n \in \{1, 2, \dots, N\}$ , define its parent nodes  $Parents_A(X_n)$ .

- (2) Calculate the Conditional Probabilities for Each  $X_n$  from the Dataset:

From dataset  $\mathbf{D}$ , calculate the conditional probability  $P(X_n = s_{nk} | Parents_A(X_n) = s_{nj})$  for each state  $s_{nk}$  of node  $X_n$  and each state combination  $s_{nj}$  of its parent nodes  $Parents_A(X_n)$ :

$$P(X_n = s_{nk} | Parents_A(X_n) = s_{nj}) = \frac{\sum_{m=1}^M I(x_{n,m} = s_{nk}, Parents_A(X_n) = s_{nj})}{\sum_{m=1}^M I(Parents_A(X_n) = s_{nj})} \quad (11)$$

Where  $I(\cdot)$  is the indicator function, returning 1 if the argument is true and 0 if false.  $x_{n,m}$  indicates the value of  $X_n$  in the  $m$ -th data point of dataset  $\mathbf{D}$ .

After computing the conditional probabilities for node  $X_n$ , store them as the CPD of  $X_n$ . After completing this procedure for all nodes  $X_n$ , combine these CPDs to construct the CPD for the entire Bayesian network.

- (3) Maximum Likelihood Estimation of Parameters:

From the obtained CPD, determine the parameter  $\theta$  that maximizes the likelihood function. For the likelihood function

$$L(\theta; \mathbf{D}) = \prod_{m=1}^M P(d_m | \theta) \quad (12)$$

use the following maximum likelihood estimation to find the parameter  $\theta$  that maximizes the likelihood function:

$$\hat{\theta} = \arg \max_{\theta} L(\theta; \mathbf{D}) \quad (13)$$

- (4) Model Evaluation:

Once the parameter  $\hat{\theta}$  that maximizes the likelihood function is obtained, compute the likelihood function value for dataset  $\mathbf{D}$  using  $\hat{\theta}$  and evaluate the model with the following formulas (Schwarz, G., 1978; Akaike, 1974):

$$\begin{aligned} \text{Bayesian Information Criterion (BIC): } & -2 \log L(\hat{\theta}; \mathbf{D}) + p \log M \\ \text{Akaike Information Criterion (AIC): } & -2 \log L(\hat{\theta}; \mathbf{D}) + 2p \end{aligned} \quad (14)$$

### Constructing the Bayesian Network for the Regional Healthcare Model

In building the regional healthcare model, we categorize the data into layers: Layer  $L_1$  for personal attributes such as gender, drinking and smoking habits; Layer  $L_2$  for examination items; and Layer  $L_3$  for diagnoses related to lifestyle diseases. The Bayesian network is then constructed following this layered hierarchy (Figure 1). The network is subsequently restructured to reflect this hierarchical layering.

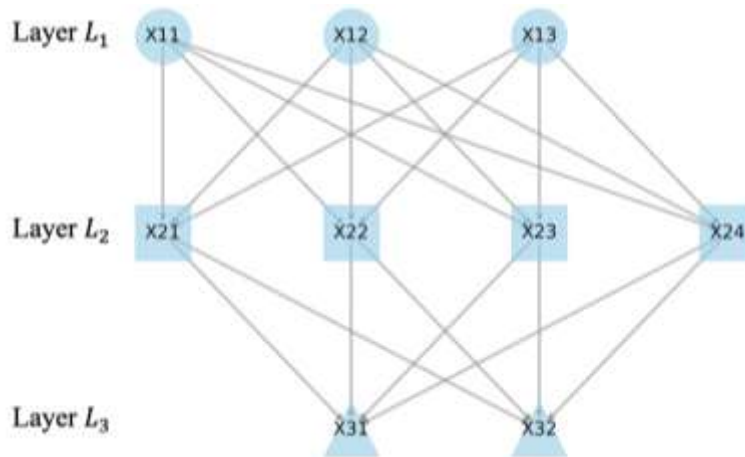

Figure 1: Bayesian Network in Three Layers: Personal Attributes, Examination Items, and Diagnosis.

For the node set  $V_N = \{X_1, X_2, \dots, X_N\}$ , we have

$$V_N = \bigcup_{l=1}^L V_l \quad (15)$$

where  $V_l$  represents the set of nodes belonging to layer  $l$  ( $1 \leq l \leq L$ ) with  $L$  being the number of layers. Given the constraint that there are no edges between nodes within the same layer, we get

$$\forall X_r, X_t \in V_l \Rightarrow A_{rt} = 0 \quad (1 \leq l \leq L, 1 \leq r, t \leq N) \quad (16)$$

Moreover, if  $X_r$  belongs to a layer higher than  $X_t$ , given the constraint that no edge exists, it is defined as

$$\forall X_r \in V_i, X_t \in V_j, i > j \Rightarrow A_{rt} = 0 \quad (1 \leq i, j \leq L, 1 \leq r, t \leq N) \quad (17)$$

The Bayesian network for the regional medical model is constructed under these conditions. Furthermore, to evaluate the strength of the relationship between two nodes on the constructed network, the mutual information is calculated as:

$$I(X_r; X_t) = \sum_{s_{ri} \in S_r} \sum_{s_{tj} \in S_t} P(X_r = s_{ri}, X_t = s_{tj}) \log \left( \frac{P(X_r = s_{ri}, X_t = s_{tj})}{P(X_r = s_{ri})P(X_t = s_{tj})} \right) \quad (18)$$

## RESULTS AND DISCUSSION

### Dataset

In this study, we utilized data obtained from The National Health and Nutrition Examination Survey (hereafter, NHANES) (Centers for Disease Control and Prevention, n.d.-a), which has a format similar to the KDB owned by the municipalities. NHANES is a program designed to gather information related to the health and nutritional status of the citizens of the United States and is operated by the NCHS (National Center for Health Statistics), a part of the CDC (Centers for Disease Control and Prevention). The survey, conducted using a combination of interviews and physical examinations, produces results that are utilized in the evaluation of the prevalence of major diseases and nutritional status, as well as in public health policies and research.

The data used was collected from 2015 to 2016 and from 2017 to 2018. Table 1 shows a list of data items for each layer of the Bayesian network used. The data item names are those defined by NHANES. In this study, among all 32 items used, we targeted individuals aged 40 and above who had no missing data in four or more items. The 2015-2016 dataset included 1,451 individuals, while the 2017-2018 dataset comprised 1,588 individuals.

Table 1: List of Used Data Items

Type	Item name	Description
attributes	RIAGENDR	Gender
	RIDAGEYR	Age in years at screening
	BMXBMI	Body Mass Index (kg/m**2)
	BMXWAIST	Waist Circumference (cm)
	BMXWAIST /BMXHIP *1	Waist Circumference / Hip Circumference
	ALQ110, ALQ111 *2	Ever had a drink of any kind of alcohol
	HSD010	General health condition
	DBQ700	How healthy is the diet
	PAQ635	Walk or bicycle
	RXDUSE	Taken prescription medicine, past month
SMQ040	Do you now smoke cigarettes?	
examinations	BPXPLS	60 sec. pulse (30 sec. pulse * 2)
	BXPULS	Pulse regular or irregular?
	BPXSY1	Systolic: Blood pres (1st rdg) mm Hg
	BPXDI1	Diastolic: Blood pres (1st rdg) mm Hg
	URXUMS	Albumin, urine (mg/L)
	URDACT	Albumin creatinine ratio (mg/g)
	LBDHDD	Direct HDL-Cholesterol (mg/dL)
	LBXTR	Triglyceride (mg/dL)
	LBDLDL	LDL-Cholesterol, Friedewald (mg/dL)
	LBXTC	Total Cholesterol (mg/dL)
	LBXGH	Glycohemoglobin (%)
	LBXGLU	Fasting Glucose (mg/dL)
diagnoses	BPQ020 *3	Ever told you had high blood pressure
	BPQ080 *3	Doctor told you - high cholesterol level
	HSQ500 *4	SP have head cold or chest cold
	HSQ510 *4	SP have stomach or intestinal illness?
	HSQ520 *3	SP have flu, pneumonia, ear infection?
	DIQ010 *3	Doctor told you have diabetes
	DIQ160 *3	Ever told you have prediabetes
	DIQ170 *3	Ever told have health risk for diabetes
	KIQ022 *3	Ever told you had weak/failing kidneys?

\*1 The waist-hip ratio is calculated using the value derived from the circumference of the waist to the hip (BMXWAIST/BMXHIP) in the NHANES data. It is only used for the 2017-2018 data.

\*2 For the years 2015-2016, it is ALQ110, and for 2017-2018, it is ALQ111.

\*3 Questions related to whether it was diagnosed by a doctor or said to have a tendency.



\*4 Judgement by the subject themselves.

Some attribute items and inspection items are real values, therefore the data was discretized. For data discretization, values lower than the international standard are labeled as 'Low,' values higher than the standard are labeled as 'High,' and values within the standard are labeled as 'Std' (standard). For certain inspection items, ranges exceeding 'High' are categorized as 'VHigh' (very high). If the data is missing, they are labeled as 'None'. International standards for inspection items are listed in Table2. For age (RIDAGEYR), the data were discretized in 10-year intervals.

Table 2: International Standards for Inspection Items

Item	International Standard Document	Low	Std	High	VHigh
BPXPLS	Cleveland Clinic., n.d.	< 60	$\geq 60, \leq 100$	> 100	
BPXSY1	World Health Organization, n.d.-b		$\leq 140$	> 140	
BPXDI1	World Health Organization, n.d.-b		$\leq 90$	> 90	
BMXBMI	World Health Organization, n.d.-a	$\leq 18.5$	$> 18.5, < 25$	$\geq 25, < 30$	$\geq 30$
BMXWAIST	Centers for Disease Control and Prevention, n.d.-b		$M: < 101.6$ $F: < 88.9$	$M: \geq 101.6$ $F: \geq 88.9$	
BMXWAIST /BMXHIP	Alberti, K. G., & Zimmet, P. Z., 1998		$M: < 0.9$ $F: < 0.85$	$M: \geq 0.9$ $F: \geq 0.85$	
URXUMS	Centers for Disease Control and Prevention, n.d.-e		< 30	$\geq 30, < 300$	$\geq 300$
URDACT	Centers for Disease Control and Prevention, n.d.-e	$M: < 17$ $F: < 25$	$M: \geq 17, < 250$ $F: \geq 25, < 355$	$M: \geq 250$ $F: \geq 355$	
LBDHDD	Centers for Disease Control and Prevention, n.d.-e	$M: < 40$ $F: < 50$	$M: \geq 40$ $F: \geq 50$		
LBXTR	Centers for Disease Control and Prevention, n.d.-c		< 150	$\geq 150$	
LBDLDL	Centers for Disease Control and Prevention, n.d.-c		< 100	$\geq 100$	
LBXTC	Centers for Disease Control and Prevention, n.d.-c		< 150	$\geq 150$	
LBXGH	Centers for Disease Control and Prevention, n.d.-d	< 5.7	$\geq 5.7, \leq 6.4$	> 6.4	
LBXGLU	Centers for Disease Control and Prevention, n.d.-d	< 100	$\geq 100, \leq 125$	> 125	

Note: If the standards are different for males and females, they are respectively described as M and F.

### Mutual Information between All Items

In this study, with regard to the construction of Bayesian networks, we first calculated the mutual information of all data items. Then, we rebuilt and evaluated the network using a feature selection algorithm and performed a comparison.

### Calculation of Mutual Information between All Items

The mutual information between each item was computed. The results are shown in Figure 2. Although the mutual information values differ, it can be observed that the data from 2015-2016 and 2017-2018 show similar trends. In the next section, we will construct a network by eliminating edges with low relationships based on the calculated mutual information.

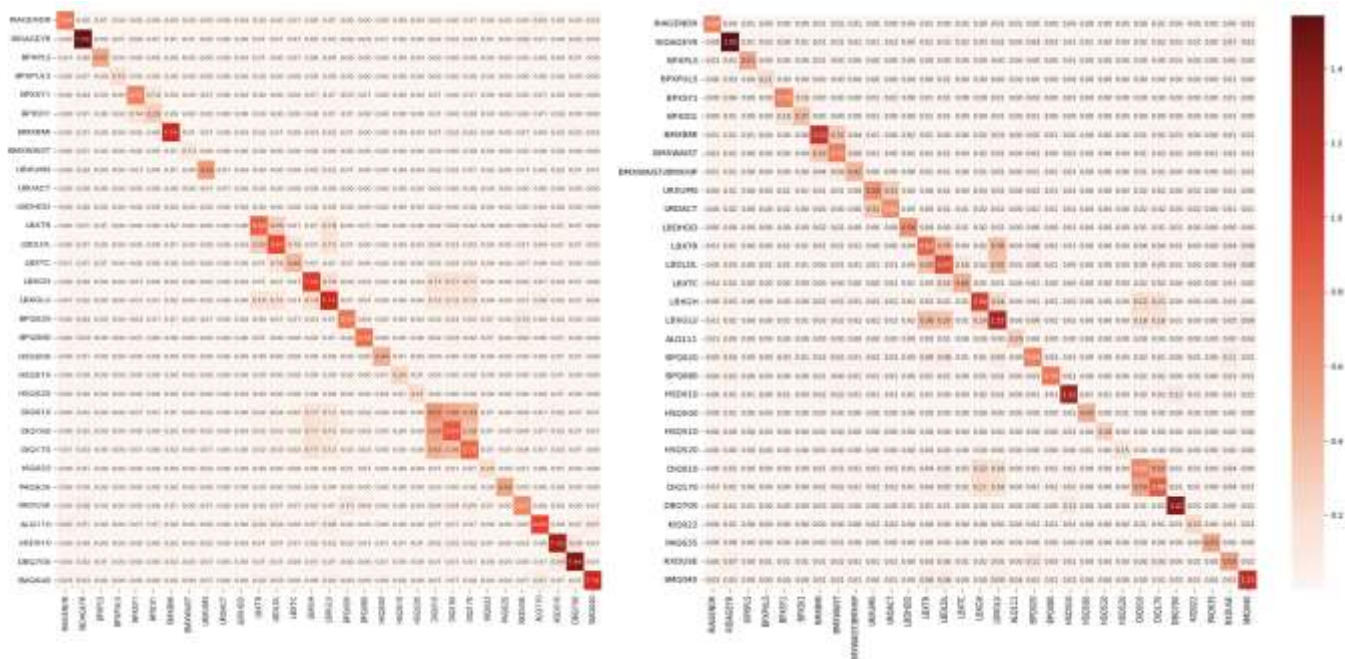

Figure 2: Mutual Information between All Items  
 Left: 2015-2016 (mean: 0.035, top 75%: 0.011), Right: 2017-2018 (mean: 0.039, top 75%: 0.015).

**Network Construction with Feature Selection**

In this study, we set a threshold of 0.01. A network was constructed by eliminating edges that had mutual information below this threshold from the previously calculated values. The constructed network is shown in Figure 3. Edges to certain items, such as pulse (BPXPPLS) and stomach or intestinal diseases (HSQ510), were removed.

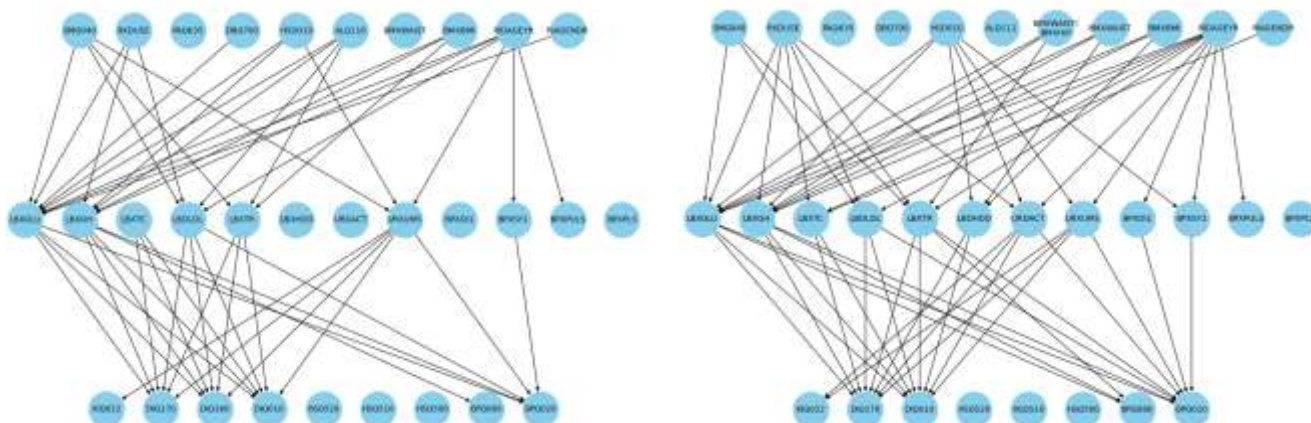

Figure 3: Bayesian Network with Feature Selection: Left - 2015-2016, Right - 2017-2018

Comparing the fully connected network that connects all edges from the attribute item layer  $L_1$  to the inspection item layer  $L_2$ , and from  $L_2$  to the lifestyle-related disease diagnosis layer  $L_3$ , with the network constructed using the feature selection algorithm, the results are shown in Table 3. As a result, for both the 2015-2016 data and the 2017-2018 data, the fully connected model showed better predictive accuracy. However, when considering the complexity of the model, the feature selection method proved to be superior. As a comparison, the evaluation of the network constructed by structural learning (Figure 4) was superior in both prediction accuracy and model complexity. However, it is believed that feature selection is better than structural learning when constructing a more general model that local government field staff can understand.

Table 3: Network Evaluation

Data set	Model	AIC	BIC
2015-2016	fully connected	40914	70287
	feature selection	42780	50077
	structural learning	30859	31075
2017-2018	fully connected	61826	130887
	feature selection	64755	100000
	structural learning	59181	59723

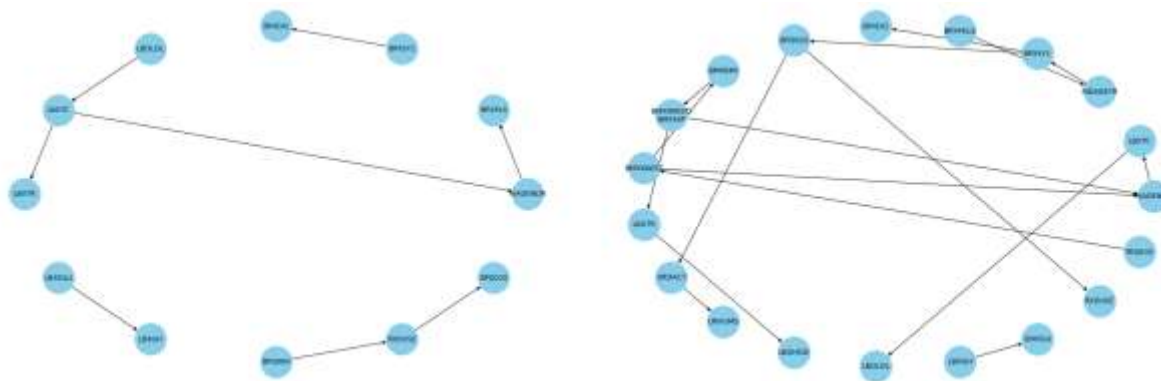

Figure 4: Structural Learning Network: Left - 2015-2016, Right - 2017-2018

Figure 5 displays the networks constructed using the feature selection algorithm for both 2015-2016 and 2017-2018, only illustrating the edges that were present in both periods. As an attribute item, age (RIDAGEYR) had the most significant influence on the inspection item layer. It is believed that health conditions change substantially depending on age. Additionally, factors like smoking (SMQ040), prescription use (RXDUSE), and health status (HSD010) had notable impacts. In terms of diagnostic items, there were many edges leading to conditions like hypertension (BPQ020) and diabetes (DIQ010, DIQ170). Previous research also employed Bayesian networks for diagnosing diabetes, and its efficacy was further confirmed in this study.

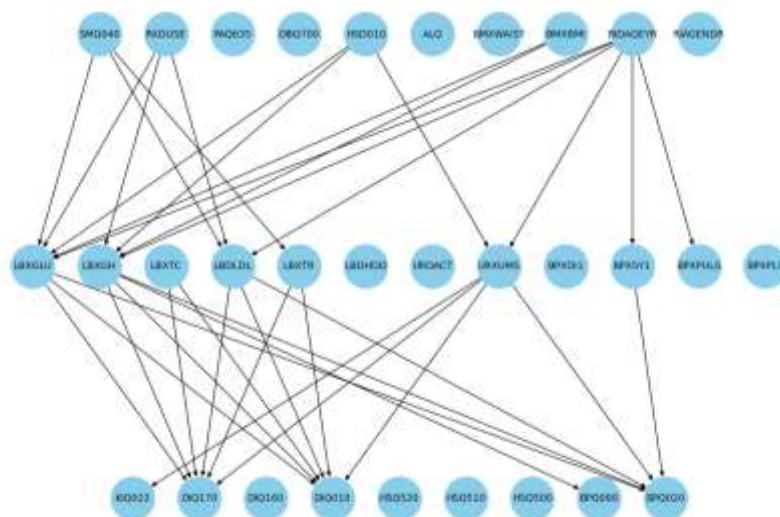

Figure 5: Shared Network Edges from Feature Selection: 2015-2016 vs. 2017-2018

**Inference**

Using the Bayesian network constructed in the previous section, inference was carried out. Figure 6 shows the probability of being diagnosed with hypertension for people in their 70s who smoke every day and those who do not, based on data from 2017-2018. The results indicate that people who smoke every day (0.56) have a lower rate of hypertension compared to those who don't smoke (0.75). For the 2015-2016 data, there was no significant difference due to smoking (0.64). Generally, nicotine contained in tobacco tends to raise blood pressure as it causes blood vessels to constrict (Benowitz, 2008). However, nicotine also has appetite-suppressing and stress-relieving effects. It's believed that these effects might be more pronounced (Audrain-McGovern & Benowitz, 2011).

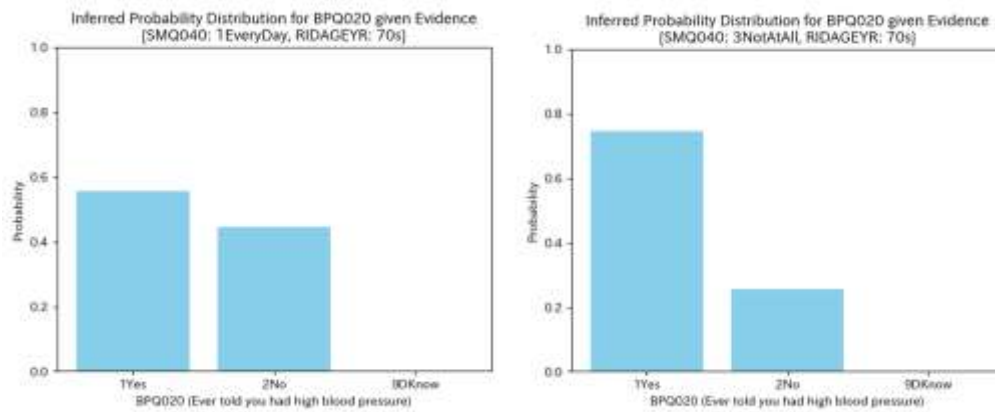

Figure 6: Inference Results: Proportion of hypertension diagnosis between daily smokers (left) and non-smokers (right)

## CONCLUSION

In this study, we developed a regional medical analysis model using Bayesian networks with open data from the United States. By dividing the model into multiple hierarchical layers, it became more comprehensible for local government staff. In particular, we demonstrated that networks developed through feature selection are useful in general model construction. Naturally, the model selected by feature selection varies depending on the data target period, so it is necessary to continue examining which kind of network is best using large-scale data in future model construction. Including patient residence information, not utilized in this study, can lead to improve an understanding of the health status of each region. In the future, we aim to expand our analysis using larger data sets spanning more years and conduct studies that are more conscious of providing feedback to regions using Japan's KDB.

## REFERENCES

- Akaike, H. (1974). A new look at the statistical model identification. *IEEE Transactions on Automatic Control*, 19(6), 716-723. <https://doi.org/10.1109/TAC.1974.1100705>
- Alberti, K. G., & Zimmet, P. Z. (1998). Definition, diagnosis and classification of diabetes mellitus and its complications. Part 1: Diagnosis and classification of diabetes mellitus provisional report of a WHO consultation. *Diabet Med*, 15(7), 539-553. [https://doi.org/10.1002/\(SICI\)1096-9136\(199807\)15:7<539::AID-DIA668>3.0.CO;2-S](https://doi.org/10.1002/(SICI)1096-9136(199807)15:7<539::AID-DIA668>3.0.CO;2-S)
- Audrain-McGovern, J., & Benowitz, N.L. (2011). Cigarette Smoking, Nicotine, and Body Weight. *Clin Pharmacol Ther*, 90(1), 164-168. <https://doi.org/10.1038/clpt.2011.105>
- Benowitz, N.L. (2008). Clinical pharmacology of nicotine: implications for understanding, preventing, and treating tobacco addiction. *Clin Pharmacol Ther*, 83(4), 531-541. <https://doi.org/10.1038/clpt.2008.3>
- Cabinet Office Japan. (2022). Annual Report on the Ageing Society [Summary] FY2022. Retrieved from <https://www8.cao.go.jp/kourei/english/annualreport/2022/pdf/2022.pdf> (accessed 5 September 2023).
- Centers for Disease Control and Prevention. (n.d.). About NHANES. Retrieved from [https://www.cdc.gov/nchs/nhanes/about\\_nhanes.htm](https://www.cdc.gov/nchs/nhanes/about_nhanes.htm) (accessed 26 August 2023).
- Centers for Disease Control and Prevention. (n.d.). Assessing Your Weight. Retrieved from <https://www.cdc.gov/healthyweight/assessing/index.html> (accessed 5 September 2023).
- Centers for Disease Control and Prevention. (n.d.). Cholesterol: About Cholesterol. Retrieved from <https://www.cdc.gov/cholesterol/about.htm#optimal> (accessed 5 September 2023).
- Centers for Disease Control and Prevention. (n.d.). Diabetes: Getting Tested. Retrieved from <https://www.cdc.gov/diabetes/basics/getting-tested.html> (accessed 5 September 2023).
- Centers for Disease Control and Prevention. (n.d.). Glossary. Retrieved from <https://nccd.cdc.gov/ckd/help.aspx?section=G> (accessed 5 September 2023).
- Chang, Y., Liu, L., Kang, X., & Wang, F. (2022). Decomposition-Based Bayesian Network Structure Learning Algorithm for Abnormality Diagnosis Model for Coal Mill Process. *Electronics*, 11, 3870. <https://doi.org/10.3390/electronics11233870>
- Cleveland Clinic. (n.d.). Pulse & Heart Rate. Retrieved from <https://my.clevelandclinic.org/health/diagnostics/17402-pulse--heart-rate> (accessed 5 September 2023).
- Di, R., Li, Y., Li, T., Wang, P., & He, C. (2022). Research on Dynamic Programming Strategy of Bayesian Network Structure Learning. *Scientific Programming*, vol. 2022, Article ID 4391071, 14 pages. <https://doi.org/10.1155/2022/4391071>
- Heckerman, D. (1995). A tutorial on learning with Bayesian networks. In *Learning in graphical models* (pp. 301-354). Springer, Dordrecht.
- Igarashi, M., Okuyama, K., Ueda, N., Sano, H., Takahashi, K., Qureshi, Z. P., Tokita, S., Ogawa, A., Okumura, Y., & Okuda, S. (2022). Incremental medical cost of delirium in elderly patients with cognitive impairment: analysis of a nationwide administrative database in Japan. *BMJ Open*, 12(12), e062141. <https://doi.org/10.1136/bmjopen-2022-062141>



- Ke, X., Keenan, K., & Smith, V.A. (2022). Treatment of missing data in Bayesian network structure learning: an application to linked biomedical and social survey data. *BMC Medical Research Methodology*, 22, 326. <https://doi.org/10.1186/s12874-022-01781-9>
- Koller, D., & Friedman, N. (2009). *Probabilistic graphical models: principles and techniques*. MIT press.
- Kyrimi, E., Dube, K., Fenton, N., Fahmi, A., Neves, M. R., Marsh, W., & McLachlan, S. (2021). Bayesian networks in healthcare: What is preventing their adoption? *Artificial Intelligence in Medicine*, 116, 102079. <https://doi.org/10.1016/j.artmed.2021.102079>
- Liu, M., Zhou, Y., & Sun, L. (2022). Risk Prediction of Gasifier System Based on Dynamic Cloud Bayesian Network. *Journal of Physics: Conference Series*, 2381(1), 012103. <https://doi.org/10.1088/1742-6596/2381/1/012103>
- Miyauchi, Y., Nishimura, H., & Nakano, Y. (2016). A Study of Bayesian Network Model Related to the Specific Health Checkup based on Lifestyle Factor Analysis. *Transactions of Japan Society of Kansei Engineering*, 15(7), 693-701. <https://doi.org/10.5057/jjske.TJSKE-D-16-00014> (in Japanese)
- National Health Insurance Central Union. (n.d.). KDB System. Retrieved from <https://www.kokuho.or.jp/hoken/kdb.html> (accessed 24 March 2022) (in Japanese).
- Neapolitan, R. E. (2004). *Learning Bayesian networks (Vol. 38)*. Upper Saddle River: Pearson Prentice Hall.
- Sasaki, K., Kuno, F., & Okada, Y. (2019). Prediction of regional health using Bayesian networks. *Communications of the Operations Research Society of Japan*, 64(7), 399-405. Retrieved from <https://cir.nii.ac.jp/crid/1520290883348595584> (in Japanese)
- Schwarz, G. (1978). Estimating the dimension of a model. *The Annals of Statistics*, 6(2), 461-464. <https://doi.org/10.1214/aos/1176344136>
- Toriumi, K., Ikata, Y., Kuno, F., & Okada, Y. (2018). Applicability of Bayesian Network to Regional Health Policy in Japan. *Proceedings of the Institute of Statistical Mathematics*, 66(2), 267-278. <https://cir.nii.ac.jp/crid/1050845763483903872> (in Japanese)
- Tummers, S.C.M.W., Hommersom, A., Lechner, L., et al. (2022). Determinants of physical activity behaviour change in (online) interventions, and gender-specific differences: a Bayesian network model. *International Journal of Behavioral Nutrition and Physical Activity*, 19, 155. <https://doi.org/10.1186/s12966-022-01381-2>
- World Health Organization. (n.d.). Body Mass Index (BMI). Retrieved from <https://www.who.int/data/gho/data/themes/topics/topic-details/GHO/body-mass-index> (accessed 5 September 2023).
- World Health Organization. (n.d.). Hypertension. Retrieved from <https://www.who.int/news-room/factsheets/detail/hypertension> (accessed 5 September 2023).

## Dialogues of Creation: Collaborative Content Generation by the Human Author and ChatGPT and its Impact on the Evolving Intellectual Property Landscape

Ya-Chen Liu<sup>1,\*</sup>  
Chen-Ho Kuo<sup>2</sup>  
Guo-Hua Wang<sup>3</sup>

---

\*Corresponding author

<sup>1</sup> HEC Liège Executive Education, Management School-Liège Université, Liège, Belgium, Executive Doctorate in Business Administration EDDBA Student, janeycl@gmail.com

<sup>2</sup> HEC Liège Executive Education, Management School-Liège Université, Liège, Belgium, Executive Doctorate in Business Administration EDDBA Student, alex.kuo@riversoft.com.tw

<sup>3</sup> Writer, Taipei, Taiwan, original.workroom@gmail.com

### ABSTRACT

The paradigm of content creation and intellectual property (IP) is undergoing an unprecedented shift fueled by AI, with ChatGPT at its forefront. This study presents a distinctive approach—a dialogue between a human author and ChatGPT—to explore their collaborative impact on creative content generation, redefining authorship and reimagining the intellectual property landscape.

As AI blurs distinctions between traditional authorship and machine-generated influence, questions emerge about attributing creative ownership, ethical considerations, and the economic valuation of AI's contributions. The human author's collaboration with ChatGPT reveals motivations that extend beyond innovation, encompassing a horizon of narrative experimentation with unique challenges. The subsequent interviews capture the evolving discourse, uncovering that while AI-generated concepts may not inherently spark entirely novel ideas, with careful human guidance, they act as catalysts for enhancing creativity. This dialogue also delves into the complexities of authorship in an AI-infused landscape. It probes the extent to which AI-generated ideas resonate with the author's artistic intent and the challenges of maintaining authorial voice in a dynamic, collaborative environment.

Utilizing qualitative methods, this research seeks to illuminate AI's influence on human authors' creative processes, dissect the intricate interplay between human creativity and AI-generated content, and critically assess the profound implications for established concepts of authorship and the evolving dynamics of the IP economy—an arena witnessing disruption due to the increased prevalence of AI-infused work. The evolving definition of authorship and content ownership catalyzed by AI-generated contributions calls for a fundamental reassessment of the traditional IP models.

Lastly, as AI-generated content becomes integral to creative works, it necessitates the emergence of new models for valuing, distributing royalties, and upholding ethical standards. We delve into the complexities of establishing fairness within this emerging model, which encompasses licensing issues related to the training data used by generative AI companies and these companies' stance on copyright ownership of the generated work. To address these challenges and the limitations inherent in current AI systems, we propose the concept of a Knowledge Graph as a valuable tool to serve as human guidance in AI-generated work. We suggest that the design of these knowledge graphs may play a pivotal role in shaping the future of the intellectual property economy.

In essence, the research presents an unconventional exploration of the partnership between human authors and AI. Through this dialogue, the study not only unveils how they redefine creativity and authorship but also highlights the transformative impact on the IP economy. The outcomes of this research offer valuable recommendations for creators, industries, and policymakers to navigate this evolving landscape.

*Keywords:* ChatGPT, Artificial Intergence, Collaborative content creation, Intellectual property economy

## 1. INTRODUCTION

In the rapidly evolving landscape of creative content generation, the partnership between human authors and artificial intelligence (AI) has introduced new dimensions to the concept of authorship. This research delves into this transformative relationship, focusing on the interplay between a human author and the AI model ChatGPT. Through this unique collaboration, we aim to uncover the intricate dynamics that emerge when human creativity converges with AI assistance.

One of the key contributors to this study is Wang, who is also a co-author of this research paper. Wang is an accomplished author, playwright, and editor with a portfolio of published works in wide-ranging genres from film critics, social and cultural issues to psychology. Wang's experience in using ChatGPT to create three original e-books to date serves as a focal point for exploring the nuances of collaborative content creation. By delving into Wang's journey, we seek to unearth the challenges he encountered and the novel perspectives he gained on the essence of authorship in the age of AI.

Beyond the personal narrative, this research extends its focus to the broader implications of AI-augmented authorship. By examining the collaborative writing process between Wang and ChatGPT, we aim to unravel the multifaceted implications for creativity, authorial identity, intellectual property, copyright, and the overall dynamics of the publishing industry. From a creative, industrial, social, ethical, and legal perspective, this study endeavors to shed light on the transformations AI brings to the realms of content creation, authorship, and the intricate web of intellectual property economy. As AI becomes increasingly integrated into the creative process, understanding these implications becomes pivotal for both scholars and industry stakeholders alike.

In summary, here are the research questions we aim to explore:

1. How does the collaborative integration of ChatGPT as a creative partner influence the creative content generation process for a human author?
2. In light of the evolving partnership between human authors and AI models like ChatGPT, how does the concept of authorship undergo transformation?
3. What are the ethical considerations associated with attributing creative ownership in the collaborative authorship between human authors and AI, and how do these considerations intersect with the changing landscape of content generation and intellectual property rights?
4. How does the incorporation of AI-generated content into creative works impact the traditional models of the intellectual property economy, and what innovative frameworks are required to ensure fair compensation for both human and AI contributions?

## LITERATURE REVIEW

### Evolution of AI in Creative Content Generation

Advancements within the field of artificial intelligence (AI) have been monumental. Notably, we have already witnessed IBM's computer Deep Blue achieving victory over human chess champions in 1997 (IBM, 2011), as well as AlphaGo, a computer program, surpassing professional human players in the ancient board game of Go in 2015 (AlphaGo, 2023). Furthermore, Google's DeepMind AI demonstrated its prowess by defeating skilled human players in the complex realm of StarCraft II (Vincent, 2019). However, it is evident that the trajectory of AI development continues to extend beyond these accomplishments. Leading the charge in AI research and development are industry giants like OpenAI and DeepMind (Lin, 2023). A prominent strand of these advancements is the emergence of generative pre-trained machine learning models, exemplified by the likes of ChatGPT (GPT stands for Generative Pre-trained Transformer), which strive to replicate human creative capabilities.

OpenAI, established in 2015, as a prominent AI research and development firm headquartered in the United States, introduced ChatGPT in May 2020 and made it publicly available in late 2022. Since its release, it is reported to have attracted over 100 million monthly users in two months' time (Garfinkle, 2023), breaking the records of TikTok or Instagram. ChatGPT is a meticulously trained AI model designed for interactive dialogue (OpenAI, 2022). It is able to answer follow-up questions, admit mistakes, and even challenge incorrect premises in reasoning or reject inappropriate requests. It also adeptly executes instructed tasks in response to written prompts provided by human users.

ChatGPT has impressed the world with its remarkable capability to generate content in various structured languages, encompassing a spectrum of formats including but not limited to poetry, PowerPoint presentations, culinary recipes, essays, computer codes, and even facilitate language translation tasks. Additionally, it excels in the art of summarization, efficiently condensing lengthy texts, and has the aptitude to craft well-structured outlines. Moreover, it provides editing assistance for written compositions, enhancing the overall quality of the content. (Gleason, 2023).

### AI-Human Collaboration in different sectors

#### *Human Collaboration in the Music Industry*

The integration of AI and human collaboration in creative endeavors is already evident in the music industry. According to Deltorn and Macrez (2018), the utilization of computers in music composition traces its origins back to the late 1950s when productions began to leverage compositional rules encoded in algorithmic languages. Recent advancements in deep learning techniques, accompanied by increased access to substantial computational resources and digitized training datasets, makes it now feasible to train neural networks on compositions by classical maestros, resulting in polished musical compositions with minimal human intervention.



These developments have given rise to a new generation of creative musical tools that cater to both professionals and amateurs, paving the way to the production of musical artworks en masse, signifying the potential of AI-Human collaboration in the creative industry. According to Dysart (2018), AI music composers may inspire millions of music consumers to start creating their own songs, whereas Jean-Pierre Briot, research director at France's National Center for Scientific Research, took the view that AI's main role should be to help musicians to compose and produce good music, rather than to look to AI alone either for head-turning compositions or to help amateurs produce a masterpiece.

### ***Impact of ChatGPT in the Academic writing***

In the realm of scientific writing, ChatGPT and similar generative AI tools has fundamentally transformed the existing ecosystem. Scholars such as Lucey and Dowling (2023) contend that AI can produce academic papers good enough for academic journals. As of January 2023, the journal Nature reported ChatGPT being recognized as a co-author in at least four academic papers (Stokel-Walker 2023). In response to this development, some of the world's most famous academic journal publishers have banned their authors from using Chatbot. Their rationale cites concerns related to accountability, credibility, transparency of information sources, as well as the potential impact on issues of authorship and originality (Holden Thorp, 2023).

On the other hand, Polonsky and Rotman (2023) emphasize the value of ChatGPT in helping to identify previously unidentified relationships in the research data and its ability in synthesising and explaining information to external audiences, and further argue for its formal co-authorship status in the academic publishing context. Alshami et al. (2023) highlight the exceptional performance in supporting the systemic review process, significantly reducing the time needed for literature search, screening, data extraction and content analysis. Ueda and Yamada (2023) argue for the essential value of ChatGPT in working alongside non-English-speaking researchers as an English proofreader in scientific writing to overcome language barriers.

Certain scholars have posited that the integration of AI into academic writing prompts inquiries concerning transparency and authorship. Additionally, it alludes to a potential transformation in the role of scholars, wherein emphasis shifts from merely seeking and articulating conclusions to the more critical task of formulating precise questions. (Jabotinsky and Sarel, 2023)

### ***AI-Human Collaboration in the Content Generation Industry***

The emergence of AI-generated content represents a pivotal shift in the content industry. Researchers such as Lin (2023) highlight the transformative impact of generative AI technology, with models like ChatGPT pushing the boundaries of what AI can achieve in creative content generation. AI models are increasingly capable of producing diverse forms of content, blurring the lines between human and machine-generated works.

In the context of book publishing, ChatGPT has been credited as the sole author or coauthor of over 200 books available for purchase on Amazon's online bookstore as of February 2023 (Nolan 2023). It should be noted that the actual count of books authored by ChatGPT may potentially exceed this number, as Amazon's guidelines do not mandate users to explicitly disclose the utilization of AI in the creation of literary works. The genres of these publications encompass a diverse range, including instructional guides on operating ChatGPT, literature tailored for young readers, collections of poetry, and other literary forms. One of the most topical example is the book "Impromptu: Amplifying Our Humanity Through AI", co-authored by ChatGPT and Reid Hoffman, the LinkedIn cofounder, and former board member of OpenAI. This book was released in March 2023, first book written with GPT-4. (Varanasi 2023).

Books generated by or with ChatGPT typically require significantly shorter production times in comparison to those authored by humans. However, critiques of these AI-generated books often center on issues such as subpar writing quality and a perceived lack of emotional depth. Additionally, notable instances, such as the case of the renowned Sci-Fi magazine *Clarkesworld Magazine*, have come to light wherein the inundation of AI-generated stories has necessitated the suspension of submissions. This highlights the publishing industry's ongoing challenge of effectively adapting to and managing the rapidly advancing landscape of technological innovation. (Cao 2023)

### **How AI-augmented Authorship Challenges Traditional Authorship Paradigms**

The nature of AI-Human collaboration in the content generation process, where human authors often work alongside AI systems to co-create content, challenges traditional notions of authorship, as creative input becomes a shared effort between humans and machines.

In the context of academic writing, the utilization of ChatGPT presents intricacies in terms of transparency (Jabotinsky and Sarel, 2023). While it may not assume the role of a co-author in the traditional sense, its capacity to produce original text necessitates a nuanced equilibrium between recognizing its input, on one hand, and upholding accountability for the ultimate outcome, on the other hand.

Deltorn and Macrez (2018) emphasized that in the context of artwork generated through an "algorithmic pipeline," discerning the distinct contributions of the human creator from those of the AI system can be a notably challenging endeavor. These emerging technical intermediaries have a propensity to obscure the boundary between human and machine contributions. Such disentanglement of inputs is of paramount significance in the context of copyright attribution, where authorship hinges upon the original contributions of a human agent.

In the context of creative content generation, the integration of AI in the creative process has raised questions about authorial identity. Jabotinsky and Sarel (2023) argue that a notable qualitative distinction emerges when considering two approaches: (i) instructing AI to generically "write an article" and (ii) directing AI through detailed inquiries to elicit specific responses. While precisely demarcating these boundaries can be intricate, there should be clear distinctions at the extremes of this spectrum. Therefore, to avoid categorizing the outcome as solely AI-generated, a researcher ought to exhibit a degree of independent thought and involvement in the creative process.

### **Intellectual Property and Copyright**

AI-Human collaboration has posed significant challenges to the traditional frameworks of intellectual property and copyright. The prevailing standard posits that a work eligible for copyright protection should arise from the creative endeavor of a human author, distinct from being a mere replication of an existing work. This fundamental tenet underpins a critical criterion for copyright protection: the necessity of originality (Deltorn and Macrez, 2018).

#### ***The author needs to be a natural person***

The Court of Justice of the European Union has further elucidated the criterion of originality by asserting that an intellectual creation qualifies as the author's own if it mirrors the author's individuality. This condition is met when the author has been able to exercise their creative faculties in crafting the work through autonomous and innovative choices. Typically, this interpretation implies that the author must be a natural person. Consequently, when a creative work is entirely generated by a machine, the majority of national copyright laws would classify the work as falling into the public domain. (Deltorn and Macrez, 2018)

#### ***Assign to the user?***

In the UK, the ruling for a 1985 case concerning an automatic process for the production of a sequence of letters for a game, stated unambiguously that computer-generated work could fall under copyright protection and suggested that the user of the system could claim authorship to the output work. However, as stated in another decision of the Court of Justice of the European Union (CJEU), the criterion of originality is not satisfied where the production of the work is only "dictated by technical considerations, rules or constraints which leave no room for creative freedom." (Deltorn and Macrez, 2018). As such, the assignment of copyright to the user of the generative process will hinge on whether the user has demonstrated sufficient creative control and originality during the process.

Prominent jurisdictions globally, such as the UK, the US, France, and Germany, have traditionally embraced a minimal standard of originality. Consequently, even a modest level of human engagement in the AI creation process may meet the criteria for originality. Conventionally, human authorship is associated with the act of molding or configuring expression or elements through choices, organization, or similar methods. As one commentator has asserted, the act of selection, in conjunction with establishing the conditions that gave rise to the work's existence, can constitute the requisite originality attributed to a human in the context of machine-generated creations (Burstyn, 2015).

#### ***Assign to the programmer?***

When it comes to defining the authorship between the user of the generative process and the programmer, it makes the decision even more complex. Scholars such as Denicola (2016) posit that the copyright of the generated work will deem to belong to the user of the system or generative process. The reason for this is because the user of the generative system generally has already attained the licence or right to use the system. This gives the programmer and creator of the system the needed reward to the value of their creation. As such, it is not unfair to allocate the copyright to the person who initiated the computer generated work.

However, according to the UK law, "the author shall be taken to be the person by whom the arrangements necessary for the creation of the work are undertaken." Under this provision, the assignment of the authorship can vary depending on how the creative process work. It can be interpreted as the user of the machine, the programmer who designed the machine, or even the investor who financed the development of the system (Deltorn and Macrez, 2018).

#### ***Assign to the machine?***

The assignment of authorship to a machine seems to be outside of the current law framework, as the authorship status normally requires the presence of a "human author" (Chesterman 2023). The DABUS case in the U.S. illustrates this point further. When the inventor of DABUS filed an application for the patent to be assigned to the machine DABUS, which is itself an AI artist, the U.S. Patent and Trademark office and two other federal courts would not grant the machine itself the authorship status, reasoning that the machine is not human and therefore cannot own the invention. (Brittain 2023).

Currently, most jurisdictions require patent applications to disclose an inventor who is a natural person, and do not recognize AI systems as inventors or owners of patents. Some argue that this limitation hinders innovation and incentives for using AI to develop inventions, and that new policies and laws are needed to protect and acknowledge AI-generated inventions. Others contend that allowing AI systems to be named as inventors or owners of patents would have negative impacts on the patent system and on human rights and responsibilities. The USPTO, the UK Court of Appeal, and other authorities have rejected patent applications naming an AI system as the inventor, but the debate is ongoing and public consultations are being conducted. (Xie 2023)

### ***Joint Authorship?***

An alternative avenue to consider is the concept of joint authorship, as explored by Lu (2021). While this approach might appear enticing, it raises concerns about alignment with fundamental copyright principles. Joint authorship typically requires either both parties to genuinely intend to be co-authors (a common criterion in US law) or the fulfillment of collaboration criteria (more typical in UK law). However, establishing mutual intent or collaboration between an AI and a human is inherently challenging, particularly given the typical physical and conceptual separation between these entities. Similarly, achieving such mutual intent or collaboration between the user and the programmer presents difficulties, given the often considerable geographical and functional distances between them.

### ***Potential Solutions***

Padmanabhan and Wadsworth (2023) proposed a Common Law theory of ownership for AI created properties. They argued that the ancient principles originated from the handling of real and personal property can help us to navigate this rapidly changing landscape. These traditional doctrines, namely first possession and accession principles, can suitably apply in this context, and that they provide a solid foundation for allocating the human ownership of AI-generated properties.

Lu (2021) also proposes a theory of 'authorship transfer' to address the issue of allocation of authorship. The theory is based on the idea that the initial authorship of a work can be transferred from the actual creator to a constructive author who has exercised sufficient control over the creative process. Lu argues that this theory can provide a reasonable and justifiable explanation of how human authors can claim authorship of AI-created works, without violating the current copyright system and its founding principles.

### ***Ethical Considerations***

Ethical considerations loom large in discussions surrounding AI-augmented authorship. Authors like Jabotinsky and Sarel (2023) highlight the importance of accountability and transparency and the need to maintain ethical boundaries whilst make use of AI in their work. The ethical dimension of authorship is further complicated when AI-generated content is published without proper disclosure or attribution, not to mention the unlicensed content in training data. (Appel et al., 2023). Ongoing court cases have been filed against AI systems by artists and illustrators on the basis that AI systems scraped and collaging their work in training dataset without their consent. (Chen 2023).

According to Appel et al. (2023), the legal system faces the challenge of defining the scope of a "derivative work" within the context of intellectual property laws. The resolution of these legal cases against the AI systems is anticipated to depend on the interpretation of the fair use doctrine, which permits the use of copyrighted material without the owner's consent for purposes such as criticism (including satire), commentary, news reporting, teaching, scholarly research, or transformative utilization of the copyrighted content in a manner not originally intended.

### ***Creativity and AI Assistance***

#### ***Impact on Creativity***

ChatGPT's capacity to amalgamate vast datasets in novel configurations, driven by user input, positions it as a potent tool for creative endeavors. This phenomenon has already catalyzed the integration of machine learning in the composition of narratives for television series, literary works, and even within scholarly domains (Farina and Lavazza, 2023).

When it comes to the impact of AI on the research process, scholars like Chen et al. (2021) and Jha et al. (2022) contend that AI has the potential not only to provide support to researchers but also to create structures and illuminate connections that might remain unnoticed by humans. Consequently, AI tools are increasingly transcending the role of mere support for academics and are evolving into instruments that generate, guide, and articulate ideas, thus advancing knowledge in a manner reminiscent of contemporary collaborative processes.

In the realm of marketing, ChatGPT has proven to be immensely valuable, showcasing its prowess in an array of domains. Notably, it excels in automating tasks such as the creation of marketing messages, product descriptions, and social media campaigns with remarkable effectiveness and efficiency. Moreover, ChatGPT exhibits the capability to generate insights into user behavior trends and contribute to the development of new product innovations. These insights are derived from the real-time data collected from diverse sources through ChatGPT's capabilities (Rivas and Zhao, 2023).

On the other hand, there has also concerns regarding the use of ChatGPT in the creative front. Eisikovits and Stubbs (2023) argued that for the conventional artist, the journey of artistic creation constitutes an inseparable, and perhaps the most significant, aspect of their calling. Artistic endeavors garner acclaim not solely for their final outcomes but also for the toil, the imaginative exploration, and the adept involvement in the creative process. Yet, the very essence of ChatGPT and DALL-E is to render this phase obsolete, representing a fundamental redefinition of the value of art and creativity.

Furthermore, as summarized by Eisikovits and Stubbs (2023), ChatGPT has the capacity to draw information from unreliable sources, thereby potentially disseminating erroneous information, posing a substantial challenge to accountability. Moreover, it formulates responses grounded in pre-existing, inherently outdated data, sometimes resulting in repetitive and unoriginal outputs.

The integration of ChatGPT can also precipitate workforce reductions by automating creative responsibilities previously performed by humans. Additionally, without meticulous design and rigorous testing, ChatGPT has the potential to perpetuate and exacerbate societal biases.

### ***Creativity assessment***

Several research endeavors have sought to discern whether regular readers possess the acumen to differentiate between AI-generated content and that crafted by human authors. In a recent investigation conducted by Schwitzgebel et al. (2023), 425 participants were tasked with distinguishing between the works of a human philosopher and four machine-generated responses. Remarkably, expert-level participants exhibited a discernment accuracy rate of 51%, notably surpassing the chance rate of 20%. Philosophy blog readers, on the other hand, achieved a slightly lower accuracy rate, just shy of 50%. In contrast, the ordinary research participants struggled to achieve an accuracy rate slightly above the chance rate, at 20%. This outcome underscores the formidable challenge associated with distinguishing machine-generated text from content authored by human philosophers.

Another pilot study by Landa-Blanco et al. (2023) analyzing whether people rated creative writing texts differently if they believed an AI tool such as ChatGPT or a person was the author. The outcome suggests that readers do not evaluate differently, in terms of creative writing, a text attributed to a human authorship than one believed to have been written by an AI.

### **Industry Transformations**

According to Rivas and Zhao (2023), ChatGPT-based tools have the potential to bring about significant transformations in the marketing industry. They can expedite content creation for marketers, potentially achieving quality levels akin to human content creators. Additionally, these tools can enhance research efficiency, facilitate improved customer understanding, automate customer service processes, and optimize overall operational efficiency.

Furthermore, ChatGPT demonstrates substantial versatility and applicability across diverse domains, including but not limited to education, healthcare, finance, entertainment, creative writing, e-commerce, and many others (George et al., 2023). For instance, in the realm of e-commerce, companies could harness ChatGPT to provide uninterrupted automated customer service and streamline order fulfillment, thereby reducing reliance on human resources. Similarly, educators could utilize ChatGPT to craft personalized study plans tailored to individual student interests and progress, while also offering instantaneous feedback through automated grading and virtual support for answering queries. In healthcare, healthcare professionals could employ ChatGPT for symptom triage, initial consultations, and potentially even preliminary diagnoses.

The landscape of creative professions is witnessing a notable shift towards the automated generation of content, particularly evident in sectors such as sports and finance journalism, as highlighted by Wölker and Powell (2021). This transformation has the potential for further amplification, potentially leading to a reduction in staffing levels within newsrooms. Notably, the book publishing industry has also been impacted, with an increasing number of books either authored by or with the assistance of ChatGPT entering the market. However, this surge in AI-generated literary content has not been without its challenges. Many of these AI-assisted books have faced criticism due to issues related to the quality of writing and concerns about potential instances of plagiarism.

Mary Rasenberger, the executive director of the Authors Guild, a prominent writers' group, expressed apprehension about this trend. In a statement to Reuters, she remarked, "This is something we really need to be worried about, these books will flood the market and a lot of authors are going to be out of work." (Nolan, 2023) This sentiment underscores the disruptive potential of AI technologies, as they have the capacity to not only transform creative processes but also impact the livelihoods of human professionals within these sectors. This raises important questions regarding the ethical, economic, and artistic implications of AI-augmented authorship, which warrant further investigation and discussion within the academic and professional communities.

### **Research Gaps and Future Directions**

While the impact of AI, particularly ChatGPT, on creative content generation in industries like journalism and publishing has garnered attention, there exists a pressing need for more comprehensive and qualitative research. We aim to contribute to this discussion by assessing the enduring consequences on the quality of creative outputs, delving into aspects of originality, authenticity, and artistic value. Additionally, there is a critical gap in our understanding of responsible AI use in creative content industries, necessitating further exploration and the formulation of clear guidelines.

Moreover, the collaborative potential of AI and human involvement within creative content industries demands in-depth examination. This includes an exploration of the evolving roles of human creators and AI in content production, with particular attention to their implications for the creative process, artistic identity, ownership, and intellectual property. Notably, there is a less explored avenue in evaluating the extent to which AI enhances or hinders human creativity.

The legal and ethical aspects of intellectual property and copyright concerning AI-generated content present a complex landscape. Transparency, attribution, and the use of AI in content creation without proper consent, are emerging issues. Aside from discussing the evolving legal frameworks and guidelines that address authorship, ownership, and copyright in the context of AI-generated works, few studies have ventured into the realm of innovative intellectual property (IP) models. These models would

need to seamlessly integrate AI-contributed elements while preserving the authenticity of human creativity. Our research has sought to address these questions, emphasizing the need for innovative frameworks that ensure fairness and accountability.

Finally, the transformative potential of AI, exemplified by ChatGPT, across diverse industries warrants meticulous examination. Our contribution to this field lies in providing insights into the specific mechanisms through which AI can enhance productivity, stimulate innovation, and reshape established systems and practices, with a particular focus on the publishing industry.

## METHODOLOGY

### Research Design

This research employs a qualitative approach to delve into the intricate dynamics of collaborative content creation between human authors and ChatGPT. The chosen research design incorporates a case study approach coupled with in-depth interviews to gain rich insights from the participant involved.

### Case Study Approach

The case study approach allows for an in-depth exploration of a specific phenomenon within its real-life context. By focusing on a single published author's experience of using ChatGPT to write original e-books, this approach facilitates a comprehensive understanding of the collaborative process and its implications for creativity and authorship.

### Interviews with Human Author and ChatGPT

To ensure a comprehensive understanding of the collaborative creative process, structured interviews were conducted with both the human author and ChatGPT. These interviews served a dual purpose: firstly, to extract valuable insights from ChatGPT regarding its role, inherent limitations, and contributions to the author's creative process; and secondly, to gain perspectives from the human author concerning motivations, creative processes, encountered challenges, and the intricate interplay between personal creativity and AI-generated content.

To facilitate an effective dialogue, we employed a unique approach by temporarily assigning ChatGPT the role of a human author. We presented ChatGPT with the same interview questions initially designed for the human author. This method draws from role theory (Taylor et al., 2020; Philipps & Mrowczynski, 2021), which offers a framework predicting how individuals perform in specific roles and under various circumstances. Role theory is instrumental in constructing a conceptual framework that connects the attributes of an organization or an individual (Schuler et al., 1977). This approach enabled us to delve deeper into ChatGPT's self-perception regarding its role in the collaborative creative process and its perceived value in assisting the human author. Through this exercise, we aimed to gain insights into ChatGPT's perspective on its role in enhancing human creativity and fostering a synergistic partnership.

Furthermore, as part of this dialogue, we solicited comments from the human author regarding ChatGPT's responses while it assumed the role of a human author. This process served as a means of facilitating a comparative analysis, highlighting differences between ChatGPT's perceptions and those of the human author in response to the interview questions. This comparative analysis adds depth to our exploration of the collaborative creative process.

### Data Selection

#### Selection of Participants

The human author selected for this study is a published writer, Guo Hua Wang, who is also a co-author of this research paper. Wang is an accomplished author, playwright, and editor with a portfolio of published works in wide-ranging genres from film critics, society to psychology. He has been making a living on writing books over the past couple of decades. He wanted to test whether ChatGPT could really write books, so within nearly four months, he guided ChatGPT in creating three native e-books. The three original e-books are published by Li Ming Cultural Enterprise Co., Ltd. and available for sale on the mainstream online bookstores in Taiwan for a sales price of 99 New Taiwan Dollars per e-book. These e-books have addressed different subjects, ranging from social psychology, motivation to personal growth.

Wang's background and familiarity with traditional writing methods and AI collaboration make him an ideal participant and serves as a focal point for exploring the nuances of collaborative AI-Human content creation.

On the other hand, ChatGPT's responses, based on the prompts and interview questions furnished by the authors of the research paper, constitute the second participant.

#### Interview Protocols

Structured interview protocols will guide our interviews with both Wang and ChatGPT. The interview with Wang will delve into various facets of his engagement with ChatGPT, including his motivations for utilizing the AI, insights into the creative process, the criteria governing the incorporation of AI-generated content, and reflections on the collaborative experience as a whole.

Conversely, the same interview questions for Wang are used for interviewing ChatGPT, who is asked to assume the role of the human author. ChatGPT's responses during the interview will provide insights into its self-perceived role within the creative

process. This will encompass its perceived values, strengths, and limitations, and how it navigates its creative contributions. These interviews are designed to shed light on the multifaceted dynamics of human-AI collaboration in the creative domain.

## **Data Analysis**

### ***Qualitative Analysis***

Qualitative analysis will be conducted on the interview transcripts to extract rich and nuanced insights. Thematic analysis, guided by the research questions and objectives, will be employed to identify recurring themes, patterns, and variations in the participants' responses. This analysis approach will allow for a comprehensive exploration of the complex interplay between human creativity and AI assistance.

### ***Thematic Coding***

Thematic coding involves systematically categorizing segments of the interview data into themes that capture key concepts and patterns. Initially, open coding will be conducted to identify emerging themes. Subsequently, axial coding will be performed to establish relationships between these themes, offering a deeper understanding of the collaborative authorship process. This process ensures rigor, consistency, and reliability in interpreting the qualitative data.

By combining a case study approach, in-depth interviews, and rigorous data analysis, this research methodology aims to provide a comprehensive exploration of the evolving dynamics of authorship, creativity, and intellectual property within the context of human-AI collaboration.

## **FINDINGS**

These findings arise from extensive interviews conducted with the study participants: the human author, Gui Hua Wang (hereafter referred to as "Wang"), and ChatGPT itself. Identical interview questions were presented to both Wang and ChatGPT, and their responses are presented herein. This section offers a synthesis of their viewpoints while emphasizing the disparities observed in their responses.

### **The Role of AI in Enhancing Creativity: Extending Creativity with Human Guidance**

The integration of Artificial Intelligence (AI) in the creative process has ignited discussions about its impact on human creativity. This section delves into the various dynamics of human-AI collaboration in creative endeavors, shedding light on both positive aspects and critical viewpoints.

Both participants concur that ChatGPT can be most effectively employed to augment and enrich human creativity as an exploratory collaborator. This collaborative creative process entails harnessing AI-generated prompts to stimulate reflection and evoke unconventional concepts, thereby fostering more inventive narratives. Moreover, its ability to introduce intricacy into the storyline efficiently saves Wang time that would otherwise be spent initiating the creative process from scratch. Consequently, Wang can concentrate on refining the content generated by ChatGPT to achieve the desired result.

Nonetheless, while ChatGPT plays a role in expediting the creative process and facilitating drafting and ideation, Wang underscores the pivotal role of human guidance in curating meaningful content. Drawing from Wang's experiences, while ChatGPT indeed contributes innovative concepts and engages in collaborative ideation, the "innovative concepts" suggested by ChatGPT may exhibit repetitiveness or standardization when users lack knowledge of how to adapt the "prompts." On certain occasions, even after altering the "prompts," ChatGPT may persist in proposing concepts that fall within the scope of its training data, thereby revisiting previously provided ideas.

Furthermore, ChatGPT's limited coherence and depth in generating ideas signify constraints in shaping the creative trajectory of content. Its limitations in applying common sense and logical reasoning sometimes result in ideas that are somewhat irrational or impractical. Finally, it may not possess a complete understanding of human emotions, values, and the subtle nuances within specific cultures, making it prone to producing biased content.

For authors seeking to incorporate AI into their creative process, a key perspective shift suggested was to view AI as a tool that enhances creativity rather than a replacement for human ingenuity. Human authors were advised to consider AI as a source of inspiration and innovation, using its suggestions to stimulate their own creative thinking. The overarching recommendation was to maintain a balance between AI-generated ideas and human artistic judgment.

In conclusion, while AI contributes novel cues and ideas, it remains crucial for authors to retain their artistic judgment and perspective, recognizing AI's role as a collaborative partner rather than a sole decision-maker. These findings underscore the potential of AI as a catalyst for creative exploration and innovation when used in conjunction with human creativity.

### **Unveiling the Dynamics of Human-AI Creative Collaboration**

Delving into this collaborative framework, the conversation explores various aspects, shedding light on the motivations, interaction dynamics, decision-making balance, workflow intricacies, effectiveness, and encountered challenges within this innovative process.

### ***Motivation for Usage: Exploration of New Technology and Efficiency***

While ChatGPT places emphasis on the creative stimulation it can provide as the primary driver for Human/AI collaboration, Wang, on the other hand, articulated that his primary motivation to begin employing ChatGPT for book authorship stemmed from a sense of curiosity and a fascination with experimenting with advanced AI models. His curiosity was centered around understanding the extent of ChatGPT's capabilities in enhancing the creative process. Additionally, Wang identified increased writing efficiency as another significant motivator. He noted that ChatGPT's capacity to rapidly generate book outlines and drafts effectively reduces the time needed for pre-writing activities.

#### ***Collaboration Workflow: Iterative Interaction***

Drawing from Wang's extensive experience in collaborative book writing with ChatGPT, the collaborative workflow commences with a clear blueprint of the intended content, and a concise prompt, with AI-generated responses acting as the initial seeds for further elaboration. Subsequently, Wang engages in an iterative editing process, meticulously refining the AI-generated content to harmonize with his artistic vision. Crucially, he iteratively updates the prompts based on the quality of the AI-generated output during this refinement phase. Maintaining emotional resonance, narrative coherence, and alignment with the overarching writing objectives are central considerations during the editing process. Striking a balance between personal creative vision and AI-generated content emerged as a critical consideration.

Wang underscores that the primary strategy for enhancing the text generated by ChatGPT hinges on "optimizing the content of prompts." Ensuring that the text produced by ChatGPT attains substantive depth necessitates that the prompts supplied to ChatGPT exhibit a corresponding level of intricacy and profundity.

#### ***Challenges and Limitations***

Based on insights gleaned from interviews conducted with both Wang and ChatGPT itself, it becomes apparent that despite ChatGPT's impressive ability to produce text that closely mimics human writing, a spectrum of notable challenges and limitations comes to the fore. These observed constraints, which manifest during its operational deployment, serve to provide a comprehensive perspective on its performance within diverse contextual scenarios. Table 1 below summarizes its limitations.

Table 1: ChatGPT's Challenges and Limitations

<b>Limitation</b>	<b>Description</b>
1. Keyword-based Response	Responses rely heavily on keywords, potentially missing context.
2. Context Awareness	Struggles with maintaining coherent conversation threads.
3. Seamless Integration	Difficulty integrating generated content into narratives.
4. Emotional Depth	Often lacks emotional nuance and depth in responses.
5. Repetition and Verbosity	Tends to produce repetitive, verbose content.
6. Expertise and Context	Limitations in specialized knowledge and historical context.
7. Spontaneity and Novelty	Challenges in generating novel, spontaneous content.
8. Interruption of Responses	Frequently interrupts responses, disrupting conversations.
9. Limited Interpretation	Oversimplifies original content, missing nuances and complexities.
10. Response Length and Depth	Produces content that can be too concise or overly lengthy.
11. Lack of Spontaneity	Struggles to shift perspectives spontaneously.
12. Content Deviation	Difficulty maintaining consistent theme or context.
13. Inaccurate Answers	May produce answers lacking semantic accuracy.
14. Reproduction of Biases	Has the potential to reproduce biases present in training data.

*Source:* This study.

1. **Keyword-based Response:** ChatGPT's responses are primarily based on keywords in provided prompts, and it may struggle to comprehend questions in a manner similar to humans. This can lead to responses that miss the underlying context or intent.
2. **Context Awareness:** One significant limitation observed is ChatGPT's occasional lack of context awareness in its generated suggestions. It may struggle to maintain a coherent thread of conversation, leading to disjointed interactions.
3. **Seamless Integration:** The integration of AI-generated content into narratives poses challenges. ChatGPT sometimes generates responses that do not seamlessly fit into the context of the ongoing conversation or narrative, creating disruptions in the flow.
4. **Emotional Depth:** ChatGPT's responses often lack emotional depth and nuance. It may struggle to convey complex human emotions effectively, leading to responses that may appear emotionally detached or inappropriate.



5. Repetition and Verbosity: ChatGPT's performance can be marked by repetitive responses, overused vocabulary, and lengthy content. This verbosity can hinder effective communication and readability.
6. Expertise and Historical Context: Limitations become evident when ChatGPT is confronted with questions requiring specialized knowledge or historical context. It may provide responses that lack depth and accuracy in such domains.
7. Spontaneity and Novelty: ChatGPT faces challenges in generating content spontaneously with novel perspectives. It tends to rely on familiar patterns and ideas, potentially stifling creative innovation.
8. Interruption of Longer Responses: ChatGPT often displays a tendency to interrupt its responses after reaching a certain length. This behavior can disrupt the flow of conversation and limit the completeness of its answers.
9. Limited Interpretation Ability: The model often oversimplifies the original content provided, failing to grasp nuances or complexities in the text. This limitation restricts its ability to provide in-depth, contextually relevant responses.
10. Length and Depth of Response: ChatGPT tends to produce content that ranges from being overly concise and superficial to excessively lengthy with redundant information. Achieving an optimal balance in response length and depth remains a challenge.
11. Lack of Spontaneity: ChatGPT often struggles to generate content with spontaneous shifts in perspective, hindering its ability to engage in dynamic and natural conversations.
12. Content Deviation: Consistency in adhering to the intended theme or context can be challenging for ChatGPT. It may consistently generate content that deviates from the desired focus.
13. Inaccurate Answers: In certain cases, ChatGPT may produce answers that lack semantic accuracy in relation to the original context. This inaccuracy can undermine the reliability of its responses.
14. Reproduce Biases: It is also observed that ChatGPT has the potential to reproduce biases present in training data.

#### ***Strategies to Address the Limitations of ChatGPT***

To mitigate these challenges outlined in the previous section and enhance the model's performance, the participants have discussed some potential strategies. (see Table 2)

Table 2: Strategies to address the limitations of ChatGPT.

Strategy	Description
1. Providing Clear Guidance and Context	Offering clear instructions and context to guide ChatGPT, using examples as references.
2. Altering Real-Life Persona	Transforming ChatGPT's persona to that of a real-world individual for improved contextual accuracy.
3. Role Playing Different Characters	Simulating multiple roles within a single interaction to generate well-rounded responses.
4. Altering Prompts with Perspective Analysis	Structuring prompts to encourage multifaceted exploration and different angles of analysis.
5. Expanding and Refining Prompts	Adding detailed prompts to ensure ChatGPT generates relevant content aligned with specific requirements.
6. Reset and Reassign	Clearing previous prompts and providing fresh roles and prompts to realign ChatGPT's focus.
7. Training with Formulaic Prompts	Using standardized prompts to maintain consistency in the author's writing style and tone.
8. Critical Review	Engaging in critical review and providing explicit guidance and context to avoid biases in content.

*Source:* This study.

1. Providing Clear Guidance and Context as Example: One effective approach is to offer clear instructions and context to ChatGPT, using examples as reference. By illustrating the expected content, users can guide the AI towards producing more relevant and on-topic responses.
2. Altering Real-Life Persona: Transforming ChatGPT's persona to that of a real-world individual can enhance relevance. This adjustment aligns the AI's responses with the characteristics and perspectives of the chosen persona, improving contextual accuracy.

3. **Role Playing Different Characters:** To achieve a more well-rounded response, ChatGPT can simulate multiple roles simultaneously. By embodying diverse personas within a single interaction, the AI generates content that considers various angles and viewpoints.
4. **Altering Prompts with Perspective Analysis:** Changing prompts to guide ChatGPT with different angles of analysis can be effective. By structuring prompts to encourage multifaceted exploration, users can steer the AI towards generating content that aligns with the desired context.
5. **Expanding and Refining Prompts:** Adding more detailed prompts can ensure that ChatGPT generates relevant content. Providing comprehensive and explicit prompts helps the AI understand the specific requirements, resulting in content that adheres closely to the intended theme.
6. **Reset and Reassign:** Clearing previous prompts and providing ChatGPT with a fresh role and new prompts can help realign the AI's focus. This approach is useful when deviations have occurred due to prior interactions, allowing for a reset in the AI's content generation.
7. **Training with Formulaic Prompts:** Using standardized prompts is another strategy to maintain consistency in the author's writing style. By providing predefined prompts that align with the author's preferred style and tone, ChatGPT can produce content that closely mirrors the desired voice.
8. **Critical Review:** To mitigate biases, engagement in critical review and provision of explicit guidance and context to AI to avoid generating biased or misinterpreted content.

Based on the above findings, we have created a table of suggested strategies to overcome ChatGPT's respective limitations. (see Table 3 below)

Table 3: Strategies to overcome ChatGPT's limitations.

Challenges and Limitations	Strategies to Overcome
1. Keyword-based Response	1. Providing Clear Guidance and Context
2. Context Awareness	2. Altering Real-Life Persona
3. Seamless Integration	3. Role Playing Different Characters
4. Emotional Depth	4. Altering Prompts with Perspective Analysis
5. Repetition and Verbosity	5. Expanding and Refining Prompts
6. Expertise and Historical Context	6. Reset and Reassign
7. Spontaneity and Novelty	7. Training with Formulaic Prompts
8. Interruption of Longer Responses	6. Reset and Reassign
9. Limited Interpretation Ability	5. Expanding and Refining Prompts
10. Length and Depth of Response	5. Expanding and Refining Prompts
11. Lack of Spontaneity	7. Training with Formulaic Prompts
12. Content Deviation	5. Expanding and Refining Prompts
13. Inaccurate Answers	8. Critical Review
14. Reproduce Biases	8. Critical Review

Source: This study.

In essence, this discussion provides an illuminating exploration of the multifaceted landscape of human-AI creative collaboration. The insights from both the human author and ChatGPT provide a nuanced perspective on the potential, dynamics, and challenges inherent in leveraging AI to enhance creative processes, enhancing our understanding of this evolving paradigm.

### **Navigating Authorship and Identity in the Realm of Human-AI Collaboration**

In this section, we delve into the intricate landscape of authorship and identity. This discourse probes the multifaceted dimensions of authorship, encompassing the redefinition of traditional concepts, concerns about originality, balancing AI dependency, and novel perspectives on ownership within the collaborative creative context.

#### ***The Symbolioic View***

When collaborating with ChatGPT in creative work, handling issues of creative ownership and attribution is a complex matter. According to ChatGPT itself, while AI models are indispensable partners in shaping the work, some consider the human author as the primary author as it is the human who make the final decisions and plan the narrative flow. Hence this relationship is symbiotic - AI generates concepts, and the human author's creative guidance and vision imbue them with depth and coherence.

### ***AI as a Collaborative Partner***

Another view considers the ChatGPT's role as a collaborative partner rather than an autonomous author. While recognizing its ability to generate content, limitations such as the lack of emotional depth and the inability to adapt to human style and preference became evident. Wang emphasized a distinct boundary between AI and human creative input, whereas over-relying on AI suggestions could impact the authenticity of their creative work. Therefore, the balance between incorporating AI-generated content and maintaining personal creative input emerged as a central concern. The importance of viewing AI as a tool rather than the foundation of their work was also highlighted. Transparently conveying the collaborative nature of the work was also essential to maintaining trust and authenticity.

### ***The Editor and Author dynamic***

Drawing from Wang's extensive experience in producing "native e-books" with ChatGPT, he underscores that the content generated by ChatGPT currently exhibits a "fragmented" nature. To interlink these disparate fragments and establish meaningful connections, the content still relies on post-editing and revision carried out by "human authors." Additionally, Wang observes notable disparities between ChatGPT's generated content and the writing style of the human author. This incongruity raises pertinent questions concerning the extent of the author's creative input and, consequently, the legitimacy of complete copyright ownership.

Challenging the notion of a "symbiotic relationship" as proposed by ChatGPT, Wang leans towards viewing this collaboration through a more hierarchical lens, akin to an "editor and author" dynamic. This alternative perspective underscores the essential role played by the human author as an editor, emphasizing their editorial influence and creative contributions alongside ChatGPT. It highlights the significance of recognizing the multifaceted roles within collaborative authorship scenarios, acknowledging both ChatGPT's contributions and the pivotal role of the human "editor" in this dynamic.

### ***Redefining Authorship***

In response to the various considerations regarding the authorship definition in an AI/Human collaboration, Wang proposed that if ChatGPT contributes to more than thirty percent of a book's content, it should be acknowledged as a co-author upon publication. If ChatGPT's contribution exceeds seventy percent, it is advisable to attribute primary authorship to ChatGPT. This recommendation is based on the potential differences in logical understanding between content generated by ChatGPT and that created by humans. Consequently, authors considering the use of ChatGPT for content creation may find it unnecessary to include their name on AI-generated content.

This discussion encapsulates the evolving understanding of authorship and identity, as unveiled by the interplay of human creativity and AI innovation. By delving into these thought-provoking dimensions, this discourse enriches our comprehension of authorship within the contemporary landscape of creative collaboration.

### ***Navigating Copyright and Intellectual Property in the Realm of AI-Generated Content***

The emergent theme of Copyright and IP elucidates the multifaceted challenges and considerations associated with managing AI-generated content.

#### ***Who Owns the Creative Output? Appropriate Attribution?***

Wang highlighted the multifaceted challenges associated with the seamless integration of AI-generated content into the final creative work, particularly in terms of delineating clear lines of creative ownership in collaborative endeavors. Ethical considerations pertaining to proper attribution emerged as a central theme, underscoring the necessity of diligently acknowledging AI-generated contributions. Moreover, Wang underscored the significance of mitigating potential conflicts and establishing mechanisms to ensure the equitable recognition of both human and AI contributions within the collaborative creative process.

#### ***Does AI-generated content entitled to copyright protection?***

Before formalizing contractual agreements, Wang recommended that a crucial assessment must be made regarding whether AI-generated content enjoys equivalent legal safeguards as human-authored works, particularly concerning "moral rights." The absence of this determination means that original content created by AI doesn't benefit from the protective coverage of copyright law. As a result, it can't be used to pursue copyright infringement cases in the same way human-authored content can.

Additionally, it's challenging to establish clear ownership of the copyright for AI-generated content. Consequently, the inclusion of AI-generated content within the purview of copyright protection should be regarded as a forthcoming imperative. Legislative bodies worldwide must expeditiously adapt with the evolving landscape of generative AI, addressing pertinent issues of safeguarding and regulation.

#### ***Do AI Providers Claim Copyright Over AI Generated Content?***

Both Wang and ChatGPT agreed that clearly defined contractual agreements with AI providers represent a pivotal measure for effectively navigating the intricate legal and ethical terrain of AI-generated content. The agreements should define the scope of authorship and ownership, and decisions regarding how to incorporate AI-generated content into the final work and whether AI providers have any claims on the end product.

The participants also raised concerns pertaining to the origins of the training data harnessed by AI developers. The legitimacy of AI developers employing data acquired from the public domain for training purposes raises substantive inquiries regarding copyright permissions.

In sum, this section encapsulates the paramount importance of addressing copyright and intellectual property issues within the context of AI-generated content creation. The insights underscore the necessity for adaptable legal and ethical frameworks that recognize the collaborative nature of creativity in the digital age.

### **Navigating ChatGPT Performance Dynamics**

This section delves into the intricate landscape of ChatGPT's performance dynamics, as perceived by users, and elucidates the multifaceted factors contributing to perceived performance decline.

#### ***User Perspective on Performance Decline***

Despite the high expectations initially set, it has been observed that ChatGPT's ability to consistently meet these expectations dwindled according to users' feedback. Wang and ChatGPT identified several factors that could contribute to the perceived performance decline. They agree that the evolution of training data was considered a key factor, potentially leading to changes in the responses and introducing bias. Technical issues, updates, and changes in the AI model were also acknowledged to affect the quality of outputs. Additionally, Wang noted the decreasing sense of novelty, and the fact that users tended to adopt a stagnant approach in interacting with ChatGPT, could also potentially contributed to their perceptions of performance decline.

#### ***Responsibility for Quality Maintenance***

Developers and stakeholders were recognized as key players in ensuring the model's continued effectiveness. User feedback was highlighted as a critical component in driving improvements and enhancing the model's performance. Continuous monitoring and improvement practices were emphasized to address any decline in performance and to sustain optimal user experiences.

In conclusion, the discussion emphasizes the collaborative nature of maintaining and improving AI model performance, reflecting the symbiotic relationship between developers, users, and the AI system itself.

### **Exploring Readers' Perspectives on AI-Human Collaboration**

This section illuminates the intricate interplay between readers and AI-generated content within the realm of AI-human collaboration.

#### ***Curiosity and Skepticism***

With ChatGPT's formal introduction to the public in November 2022 and its surge in popularity in Taiwan starting in February 2023, the adoption of ChatGPT for book composition among Taiwanese writers has been relatively limited. Consequently, the pervasive trend of utilizing ChatGPT for book writing and the readership specifically focused on "ChatGPT-authored books" have not seen substantial growth at this juncture. However, within the immediate circle of Wang, four primary inquiries have emerged: Firstly, does ChatGPT possess genuine book-writing capabilities? Secondly, what methodologies facilitate book writing using ChatGPT? Thirdly, is there a potential risk of infringing upon the copyrights of "human authors" when integrating content generated by ChatGPT? Lastly, how does ChatGPT swiftly grasp the "prompts" provided by human authors to initiate book writing?

It is crucial to emphasize that these four inquiries predominantly reflect a curiosity regarding ChatGPT's ability to engage in book writing. Concerning reader feedback on content generated by ChatGPT, skepticism largely prevails, particularly concerning the reliability of the responses provided by ChatGPT.

#### ***Reader's Ability to Judge and Compare***

The intricate task of differentiating AI-generated text from authentic human writing presents a captivating challenge. According to Wang and ChatGPT, there are discernible cues that readers can use to identify AI-generated content, such as unconventional plot twists, technical explanations, and a perceived deficiency in emotional depth. Conversely, characteristics indicative of human authorship encompass familiar narrative tones, narrative consistency, and the creation of well-rounded characters. Additionally, while AI introduces novel ideas, concerns about potential repetition and the use of formulaic structures have been noted. It is also a widely accepted notion that human authors excel in eliciting emotional connections with readers.

#### ***Engage Readers with the AI Author***

In order to enhance the acceptance and appeal of ChatGPT-generated books among readers, Wang suggested innovative strategies for publishing houses. These strategies include assigning a human-like name to the AI, crafting a distinct visual persona for the AI author through animated representations, and establishing a presence on popular social media platforms such as Facebook, Instagram, TikTok, and others commonly utilized by human authors to engage with their fan base. Such an approach has the potential to shape the broader perception and future positioning of the publishing industry, bolstering the impact of ChatGPT-generated books.

In summary, this discourse has addressed the contemporary state and evolving dynamics of the reader-author relationship within the transforming publishing landscape shaped by AI. It has also shed light on potential avenues for fostering more profound reader engagement in this context.

### **Transformative Impact on the Publishing Landscape**

This section illuminates the impact of AI-human collaboration on the dynamic landscape of the publishing industry. Through comprehensive exploration, it unearths the multifaceted consequences and adaptations that the industry, authors, and readers are experiencing in the wake of this transformative partnership.

### ***Evolving the Publishing Ecosystem***

The proliferation of books generated by or in collaboration with Generative AI is poised to prompt a re-examination of the conventional roles of authors, publishers, and readers within the publishing ecosystem. Wang proposed that in this envisioned scenario, the front-end of the publishing landscape, traditionally the domain of "authors," will expand to encompass three distinct categories: "human authors," "human-AI co-authors," and "AI authors." The extent to which potential ambiguities may emerge among the works produced by these distinct author categories will hinge upon the forthcoming advancements in Generative AI technology.

### ***Lowering Entry Barriers***

Whilst ChatGPT considered that the AI-augmented publications would re-energize the publishing industry, Wang took a more concerning view. He believed that the utilization of ChatGPT for book creation will significantly lower the threshold for entering the world of publishing. Consequently, the publishing industry may become saturated with a wide range of quality, from excellent to subpar, as more individuals gain access to this creative tool. As such, the importance of managing quality and authenticity of AI-generated content to maintain the reputation of publishers was emphasized.

### ***Increased Writing Speed***

Writing books with ChatGPT allows for a considerable increase in writing speed. This phenomenon may encroach upon the space traditionally occupied by "human authors" who prefer a slower, more meticulous approach to writing. According to Wang, one book typically takes about half a year to be finished. In contrast, authors using ChatGPT could potentially write two or more books per month, resulting in the creation of ten or more books within the same six-month timeframe.

### ***Changing the Publishing Sequence***

According to Wang, the emergence of native e-books generated through ChatGPT could potentially shift the conventional publishing sequence from "Print First, Electronic Later" to "Electronic First, Print Later." Presently, most "human authors" prefer their hard-earned works to be initially published as physical books, followed by e-book releases. However, the creation of native e-books through ChatGPT could fill the gap for publishers seeking sources willing to release e-books first. This shift allows publishers to save costs and reduce inventory, potentially making "Electronic First, Print Later" a more prominent publishing process within the industry.

### ***Book Types Suitable for AI***

The suitability of AI-generated content for different book types was explored. ChatGPT suggested that AI can excel in genres like science fiction, fantasy, and mystery novels that involve rich imagination and world-building. Technical and educational content were identified as areas where AI-generated explanations could be beneficial. However, Wang noted the importance of the "human author" guiding ChatGPT to possess a basic understanding of these genres. Without a foundational knowledge of science fiction, fantasy, or mystery literature, it becomes challenging to direct ChatGPT to produce logically coherent story outlines that incorporate essential genre-specific knowledge.

### ***Impact on Small and Medium-Sized Publishers***

Wang believes that one of the major impact of AI on the publishing industry is their potential to address the issue of insufficient manuscript sources. This is particularly relevant for traditional small and medium-sized publishing houses, which often struggle with limited resources, especially in terms of manuscript sources due to financial constraints. However, if these medium and small-scale publishing houses can access high-quality manuscript sources generated by ChatGPT, they can publish the best works even with limited funds.

### ***Impact on Independent Authors***

The impact of ChatGPT on independent authors was discussed. Aside from efficient draft generation and accelerated drafting processes facilitated by AI assistance, ChatGPT also mentioned that independent authors could benefit from the opportunity to explore new genres and styles, redefine their brand perception, and amplify minority voices through AI-generated content. The democratization of content creation can expand opportunities for authors outside traditional publishing channels. However, Wang cautioned about the conceivable risk of diluting the distinct writing styles and brand identities of independent authors. He pointed out that many "human authors" who employ ChatGPT may assume that the AI can adapt to their unique "writing style." Nevertheless, they might not be fully aware that their writing style could progressively merge with ChatGPT's narrative style, potentially assimilating into the AI's writing style over time.

### ***Challenges and Risks in Branding and Marketing***

Wang noted that one of the greatest challenges faced by publishers or authors in terms of branding and marketing ChatGPT-authored books is the readers' perception and trust in ChatGPT-generated content. Since the advent of ChatGPT in November 2022, it has consistently emphasized to its "users" that the answers it provides may not always be correct. Consequently, the majority of ChatGPT users perceive it as a "writing expert" but one that often produces unseen errors. Therefore, when content created by ChatGPT is published as a book, readers naturally question the accuracy and reliability of the content.

Additionally, building reader confidence in AI-generated content requires transparency and accurate portrayal of AI's role. Apart from emphasizing to readers that "human authors" use ChatGPT as a tool to assist their writing process, and that all creative content in the book originates from the "human authors," with ChatGPT generative AI merely extending and expanding upon these ideas. This can help build trust among readers regarding "AI-authored works" and eliminate concerns about their lack of originality.

Lastly, the most significant risk for publishers or authors in terms of branding and marketing ChatGPT-authored books is whether the content inadvertently infringes on the intellectual property rights of "human authors." While ChatGPT generates content naturally based on the prompts provided by humans and theoretically should not copy and paste entire passages from others, it might reference the "unique perspectives" published by human scholars in academic papers without citing the sources properly, potentially infringing on the intellectual property rights of human experts.

In summary, this section sheds light on the transformative influence of AI-human collaboration on the publishing industry, authors, and readers. It underscores the intricate dance between creativity, innovation, challenges, and adaptations, ultimately shaping a new narrative for the future of literature and the publishing ecosystem

## DISCUSSION

### Rethinking Authorship and IP Ownership

#### *Defining the Boundaries of Authorship and the Role of Human Involvement*

As highlighted by Jabotinsky and Sarel (2023), the boundaries of authorship become increasingly complex when dealing with AI-generated content. One critical distinction lies between instructing AI to generate content generically versus directing AI through specific inquiries to elicit responses. While the demarcation of these boundaries can be intricate, it is essential to acknowledge that discernible distinctions exist at the extremes of this spectrum.

Our research supports this notion by emphasizing the significance of human involvement in the creative process. Wang's experiences underscore that, although AI expedites creativity and facilitates drafting, human guidance remains pivotal in curating meaningful content. According to Wang, "If the human guiding ChatGPT to write a book doesn't know how to write a book, then the ChatGPT they guide won't be able to produce a book that can be published and sold. It's similar to the key role in getting a "drone" to take off, where it's not the AI controlling the drone, but the "human" operating the AI's autopilot for the drone.

Another analogy proposed by Wang, "If we liken ChatGPT to the 'AI pen' that humans use for writing books, then the 'human brain' of the individuals using this 'AI pen' becomes the 'GPU' that enables the 'AI pen' to write books. In other words, if the humans using ChatGPT don't know how to write books, they won't be able to produce book manuscript content that can be published using this 'AI pen.'"

While ChatGPT contributes innovative concepts and engages in collaborative ideation, it becomes apparent that the outcomes can exhibit repetitiveness or standardization when users lack the knowledge to adapt the prompts adequately. Even when altering prompts, ChatGPT may persist in suggesting ideas within the scope of its training data, revisiting previously provided concepts. Wang further pointed out the operational limitation of ChatGPT in terms of its lack of ability to retain or recall the knowledge and data acquired during prior interactions before the system was powered down. Wang uses an analogy to the theoretical concept of parallel dimensions, where the individual in one parallel dimension (referred to as A) lacks the capacity to ascertain the actions and experiences of their counterpart in another parallel dimension (designated as B). This drawback further emphasizes the human author's role as an editor, bridging gaps in fragmented AI-generated content and maintaining a unique creative style.

These findings suggest that the human role in shaping creative content remains indispensable. It is not merely the creation of content but the ability to direct, refine, and infuse unique perspectives that defines authorship. A word of caution from our interview Wang noted that, "If you don't want to be led by ChatGPT, humans should not treat it as just a "toy" without understanding its capabilities, nor should they consider ChatGPT as the "basis" for writing any article. Instead, ChatGPT must be regarded as a "tool" for handling repetitive and complex paperwork tasks and assisting in brainstorming.

#### *Redefine authorship based on the proportion of AI-generated content.*

Our dialogue with Wang and ChatGPT offer fresh insights into the evolving terrain of authorship and identity within human-AI collaboration in creative content generation. Wang challenges the notion of a symbiotic relationship, wherein ChatGPT serves as an indispensable partner. Rather, he characterizes AI as a "collaborative partner" to assist human productivity, rather than an autonomous author nor "equal collaborators".

He cautions against AI dominance, highlights the delicate equilibrium required to integrate AI-generated content while preserving the authenticity of human creativity. He further points out that many "human authors" who use ChatGPT may believe that ChatGPT can learn their "writing style" without realizing that their own "writing style" is also gradually "blending" with ChatGPT's narrative style, and may even be assimilated into ChatGPT's AI writing style unconsciously over time.

He proposed a quantitative authorship framework, which suggests that if ChatGPT contributes more than thirty percent of a book's content, it should be acknowledged as a co-author upon publication; If ChatGPT's contribution exceeds seventy percent, primary authorship could be attributed to ChatGPT. This recommendation is rooted in the recognition of potential differences in logical understanding between AI-generated and human-created content. Authors may find it unnecessary to include their name on AI-

generated content. This proposal challenges traditional authorship norms and introduces a quantitative framework to navigate the evolving landscape of authorship in AI-infused creativity.

### ***Navigating Intellectual Property and Copyright in AI-Human Collaboration***

Our research findings contribute to the literature surrounding the evolving intellectual property (IP) economy and copyright law, shedding light on the multifaceted challenges and adaptations introduced by AI-driven content creation tools like ChatGPT.

1. **Reevaluation of Authorship and Creativity:** One of the key contributions of our research is the reevaluation of traditional notions of authorship and creativity in the context of AI-generated content. We have shown that the emergence of AI-authored and AI-assisted works challenges the conventional definition of an author, prompting a nuanced understanding of authorship categories, including "human authors," "human-AI co-authors," and "AI authors." This reevaluation is essential for modern copyright law, which hinges on the concept of authorship for protection.
2. **Acceleration of Content Creation:** The accelerated speed of content creation facilitated by AI tools poses a challenge to the traditional pace of human authors. Our research highlights how AI-generated content could surpass human-authored works in terms of sheer volume. This calls for a reassessment of copyright law's treatment of the creative process and the definition of originality, as content generation becomes increasingly automated.
3. **Shift in Publishing Sequence:** The emergence of AI-generated native e-books could lead to a shift in the traditional publishing sequence from "Print First, Electronic Later" to "Electronic First, Print Later." This transformation has implications for copyright law, as it impacts the timing of copyright registration and protection, potentially necessitating amendments to existing legal frameworks.
4. **Uniform Clarity in Copyright Stances Across AI Providers:** Our research highlights the growing importance of contractual agreements between content creators, publishers, and AI providers. This discrepancy in AI providers' policies and positions on copyright can lead to confusion and legal complexities for content creators and publishers. Therefore, it is imperative to initiate discussions aimed at establishing uniform clarity in copyright-related terms and conditions across AI providers. Achieving this clarity can streamline legal processes, ensure the protection of creators' rights, and facilitate the responsible and ethical use of AI-generated content.

In summary, our research findings provide valuable insights into the evolving IP economy and copyright law, emphasizing the need for legal adaptations to accommodate the changing dynamics introduced by AI tools like ChatGPT. These insights are pivotal for policymakers, legal scholars, and practitioners seeking to navigate the evolving landscape of creative content in the digital age.

### ***Rethinking Creativity in the Age of AI: Opportunities and Challenges***

Our research contributes to the ongoing discussion about rethinking creativity in the AI age by shedding light on several crucial aspects of this complex landscape. Here are the key points related to our research findings:

***Extending Creativity with Human Guidance:*** One of the central themes that emerges from our research is the idea that AI, exemplified by ChatGPT, serves as a valuable tool to extend and enrich human creativity. Participants in our study widely agree that the most effective utilization of AI in the creative process is as a collaborative partner. This concept aligns with the notion that AI can amplify human creativity rather than replace it. This insight underscores the potential for AI to serve as a catalyst for innovation, providing creators with new perspectives and ideas.

***Acknowledging AI's Limitations:*** Our research findings highlight the importance of recognizing AI's limitations in the creative process. As exemplified by Wang's experiences, AI-generated content can exhibit repetitiveness and standardization, particularly when users lack expertise in effectively guiding AI. Moreover, ChatGPT's limitations in coherence, depth, common sense, logical reasoning, and understanding of human emotions pose challenges. Authors are advised to strike a balance between AI-generated ideas and human artistic judgment, emphasizing the complementary nature of AI in assisting creativity rather than replacing it.

***Questioning AI's Role in Creativity:*** The integration of AI into creative processes prompts a profound reevaluation of the very essence of creativity. As argued by Eisikovits and Stubbs (2023), AI's capacity to automate creative tasks challenges long-standing conventions surrounding artistic creation. Our research underscores the limitations inherent in AI's contribution to creativity, emphasizing its propensity for lacking accountability. Furthermore, we emphasize the indispensable role of human guidance in the creative process, a factor vital for maintaining the integrity of creative outputs. Consequently, we explore the evolving role of human authors within the context of AI-assisted creative endeavors. We place particular emphasis on the imperative of transparency in attributing creative ownership. In essence, we assert that creativity in the AI age is characterized by a dynamic relationship that necessitates the development of novel conceptual frameworks and robust standards for defining creative ownership.

***Striking a Balance:*** Our research findings underscore the need for striking a balance between human creativity and AI enhancement in the creative process. This balance is crucial for navigating the evolving landscape of creativity in the AI age. It requires thoughtful consideration of when and how to leverage AI's capabilities to enhance creative endeavors while preserving the unique human touch in artistic expression. Achieving this equilibrium will be essential for realizing the full potential of AI as a creative collaborator without undermining the essence of human creativity.



In conclusion, our research provides valuable insights into the multifaceted relationship between AI and creativity. The evolving landscape of creativity in the AI age requires a delicate balance between human and AI contributions, encouraging ongoing discussions and reflections about the future of artistic and creative endeavors in this transformative era.

### **Implications for the Publishing Industry**

The rise of AI-authored and AI-assisted content marks a significant shift in publishing, introducing three authorship categories: "human authors," "human-AI co-authors," and "AI authors." ChatGPT integration democratizes publishing, potentially lowering entry barriers, albeit with varying content quality. Wang's insights hint at AI-generated content potentially surpassing human-authored works in sheer output. Wang also proposed that publishing houses that publish books created by ChatGPT must understand how to market ChatGPT as an "AI author." By giving the AI a human-like name and create a character image of this AI author through AI animation, and even establish social media profiles to interact with fans, then in the future, books published through AI may establish their own unique presence in the literary world and become a part of "AI literature."

Additionally, AI-generated native e-books may disrupt traditional publishing, favoring an "Electronic First, Print Later" model, reducing costs, and streamlining inventory. AI's proficiency spans genres, excelling in imaginative categories like science fiction and fantasy, as well as technical and educational content, but domain knowledge remains key. Generative AI aids small publishers with limited resources and empowers independent authors, yet the risk of blending author and AI styles must be considered.

Building reader confidence in AI-generated content is challenging due to concerns over accuracy and transparency. Legal and branding issues related to inadvertent intellectual property infringement also arise and warrant careful handling.

In summary, we underscore the transformative impact of AI-human collaboration on the publishing industry, and how the roles of authors, publishers, and readers are evolving in this dynamic landscape, emphasizing the intricate interplay between innovation, challenges, and adaptations that collectively shape the future of literature and the broader publishing ecosystem.

### **A New Paradigm of the Intellectual Property (IP) Economy**

The integration of AI-generated content into creative works introduces a novel dimension to the traditional models of distributing royalties and economic valuation within the intellectual property (IP) economy. This development necessitates the exploration of innovative frameworks to ensure fair compensation for all parties involved. To devise this framework, some pre-conditions need to be achieved:

1. **Ensuring Legitimacy and Licensing of Training Data:** One of the foundational prerequisites for establishing a new intellectual property framework that includes AI-generated content is the necessity to address the legitimacy and licensing of the data used to train AI systems. As previously highlighted, considerable concerns have arisen regarding the origins of the training data employed by AI developers. Therefore, resolving these concerns surrounding the sourcing of training data becomes a paramount preliminary step. At present, a multitude of active legal proceedings are underway, wherein AI developers are being sued for their utilization of copyrighted materials without proper authorization (Appel et al., 2023). The resolution of these pending legal cases holds profound implications for the trajectory of the Generative AI industry, signifying the pivotal role they play in shaping its future landscape. As of the time of writing, Shutterstock, one of the largest photo licensing service providers, has announced the measure to compensate artists and contributors if they have made their work available in the dataset for training Generative AI (Murphy 2023). Shutterstock has also promised to give contributors a choice to opt out of future dataset deals. This new compensation model has set the stage for future developments regarding value, royalties and compensations in the digital age.
2. **Establishing Industry-Wide Copyright Guidelines for AI Developers:** It is imperative that AI developers collectively agree not to assert copyright claims over content produced by their systems. Achieving a consensus within the AI developer community regarding copyright ownership of AI-generated content is crucial. Such a consensus can bring much-needed clarity to the dynamics between system users and AI developers, proactively preventing potential disputes over copyright ownership of the generated output in the future. OpenAI, the progenitor of ChatGPT, has explicitly stipulated in its publicly available terms and conditions that it "will not assert copyright over content generated by the API for you or your end users." Nevertheless, as of the time of this writing, there remains a conspicuous absence of explicit statements or clarifications regarding copyright matters pertaining to content generated by other prominent Generative AI providers, including but not limited to Google's Bard and Bing Chat. Once their stands are clarified, we can proceed with the following step.
3. **Transfer the copyright ownership to the human author:** Our research findings underscore the vital role of human authors in AI-human collaborations. To facilitate the transfer of copyright ownership to human authors, transparency regarding the respective roles and inputs of AI and humans in this collaboration is paramount. Once a fair distribution of contributions is determined, with the human author's predominant influence established, it becomes feasible to apply conventional IP models and practices, as suggested by Lu (2021) or Padmanabhan and Wadsworth (2023), to attribute or transfer ownership to human authors.
4. In the case where AI is the dominant contributor to the output, innovative frameworks will need to be developed which requires collaboration among stakeholders across the creative and AI industries, legal experts, and policymakers. Industry standards and best practices should be established to ensure consistency and fairness. These frameworks should strike a

balance that recognizes the value of both human and AI contributions while ensuring equitable compensation in the evolving landscape of creative collaborations.

### **The Imperative of a New Framework in the Generative AI Era**

The need for a new IP framework in the Generative AI age is evident when we envision a future where AI-generated content becomes the standard, with human guidance emerging as the primary influence on creativity. However, to explore the concept of human guidance, it's imperative to consider the form it will take. Here, we propose Knowledge Graph as a promising avenue for shaping creativity in the age of Generative AI.

Knowledge Graphs are structured representations of knowledge that employ a graph-based data model to connect and organize information. They consist of nodes, representing entities or concepts, and edges, depicting the relationships between these entities or concepts. Knowledge Graphs offer a robust means of representing and utilizing data in a semantic and interconnected manner. (Narasimhan 2023)

Recent research, as indicated by Sun et al. (2023), underscores the attributes of Knowledge Graphs, elucidating their capacity to provide high-quality and explicit knowledge representations. Furthermore, they are easily modifiable, addressing several drawbacks and limitations inherent in large language models (LLMs). As such, Knowledge Graphs emerge as a promising solution to the challenges faced by LLMs. They offer domain-specific knowledge, guiding Generative AI systems to yield superior, dependable outputs and mitigating issues like hallucinations in LLMs.

Researchers such as Yang et al. (2023) posit that the integration of Knowledge Graphs represents a logical progression in unlocking the potential of Generative AI tools. We posit that the design and utilization of Knowledge Graphs can be likened to the management of intellectual property or closely guarded business secrets within specific domains. Consequently, the future of the IP economy appears poised for expansion into this new arena, one centered around the creation and application of Knowledge Graphs, which serve as the bedrock for maximizing the performance of LLMs.

## **CONCLUSIONS**

**ChatGPT as a Collaborative Tool:** ChatGPT exhibits remarkable capabilities in conversation, data analysis, idea generation, and content creation. However, it is not without significant limitations, including credibility, accountability, transparency, and a limited knowledge base in specialized domains due to its training data scope. These limitations manifest prominently in the book publishing and content generation industry, leading to issues such as emotional depth, coherence, fragmented thoughts, and repetition. Consequently, the most effective role for ChatGPT is as a collaborative partner rather than a co-author. It should be regarded as a tool to aid human authors in the creative process, where human guidance remains pivotal for producing high-quality content suitable for professional contexts.

**Evolving Notions of Authorship:** Exploring authorship and identity within human-AI collaboration has unveiled a diverse range of perspectives and challenges. This exploration underscores the necessity of transcending traditional authorship concepts to adapt to the dynamic nature of creative collaboration. They emphasize the symbiotic, collaborative, and sometimes hierarchical relationships that define creative processes in the contemporary landscape. This evolving discourse reflects AI's transformative potential in reshaping how we conceive and define authorship in the digital age.

**Copyright and Intellectual Property Challenges:** The current legal framework stipulates that copyright can only be granted to natural persons. However, the attribution of authorship in AI-human collaboration presents ongoing challenges involving the human, AI developers, and the AI system itself. Resolving these challenges necessitates transparency and clarifications regarding AI providers' claims to content generated through their systems. Furthermore, ongoing court cases involving artists and writers suing generative AI companies for unauthorized use of copyrighted work in AI training have significant implications for the industry's future trajectory.

**Impact on the Publishing Industry:** Generative AI has already reshaped the publishing industry's workflow, shifting it from a "Print First, Digital Later" model to a "Digital First" approach. This change enables authors to produce manuscripts more rapidly. However, the quality of AI-human collaborative publications remains limited due to technical constraints. Reader perceptions also remain ambivalent, primarily due to concerns about AI's accountability and credibility. To realize AI's transformative potential in the publishing industry, building reader confidence in AI and ensuring transparency are critical.

**Human Guidance in the Age of Generative AI:** In a future where AI-generated content becomes commonplace, human guidance will play a pivotal role in guiding creativity and ensuring accountability in the generated output. As a promising concept for providing human guidance in the creative process in the Generative AI age, we propose Knowledge Graphs. These structured knowledge representations offer domain-specific guidance, enhancing the quality and reliability of AI-generated content.

In conclusion, the evolving landscape of Generative AI presents a host of opportunities and challenges across various domains, including content creation, authorship, copyright, publishing, and creativity. As we navigate this dynamic terrain, adapting to the changing nature of human-AI collaboration and exploring innovative solutions like Knowledge Graphs will be instrumental in harnessing the full potential of AI while addressing associated concerns.

## LIMITATION AND FUTURE RESEARCH DIRECTIONS

While this research has provided valuable insights, it also presents several limitations that open avenues for future exploration.

Firstly, the interview process involved a single human author, potentially introducing bias into the perspectives gathered. Future research could mitigate this limitation by engaging with a more extensive group of human authors. This broader sample would yield diverse viewpoints and deeper insights into their collaborative experiences with AI.

Secondly, the study's scope did not delve into readers' perceptions and attitudes toward AI-generated books, leaving a significant gap. Subsequent research should aim to uncover readers' preferences and acceptance rates, shedding light on their evolving relationship with AI-generated content.

Thirdly, the generative AI landscape is rapidly evolving, as are the legal cases surrounding copyright ownership and intellectual property violations. This study's discussions are based on events and developments up to September 2023. Future research should continue to monitor these developments, with a particular focus on the outcomes of ongoing legal cases related to AI's copyright ownership and IP infringements.

Lastly, the development of Knowledge Graphs as a complementary asset to the future of generative AI and large language models (LLMs) presents an intriguing area for ongoing observation and research. Understanding how Knowledge Graphs can enhance AI-generated content and address current limitations is a promising avenue for future exploration.

## REFERENCES

- Appel, G., Neelbauer, J., and Schweidel, D.A., (2023, April 7), Generative AI Has an Intellectual Property Problem. *Harvard Business Review*. Retrieved 8 September 2023, from <https://hbr.org/2023/04/generative-ai-has-an-intellectual-property-problem>
- DeepMind. (n.d.). AlphaGo. Retrieved September 5, 2023, from <https://www.deepmind.com/research/highlighted-research/alphago>
- Alshami, A., Elsayed, M., Ali, E., Eltoukhy, A. E. E., & Zayed, T. (2023). Harnessing the Power of ChatGPT for Automating Systematic Review Process: Methodology, Case Study, Limitations, and Future Directions. *Systems*, 11(7), 351. <https://doi.org/10.3390/systems11070351>
- Brittain, B. (2023, January 12). Computer scientist says AI 'artist' deserves its own copyrights. Reuters. Retrieved on September 8, 2023, from <https://www.reuters.com/legal/litigation/computer-scientist-says-ai-artist-deserves-its-own-copyrights-2023-01-11/>
- Burstyn, N. F. (2015). Creative Sparks: Works of Nature, Selection, and the Human Author, *39 Colum. J.L. & Arts*, 281, 283
- Cao, S. (2023, February 22). ChatGPT Abuse Is Forcing a Popular Sci-Fi Magazine to Suspend Submissions. *Observer*. Retrieved on September 20, 2023, from <https://www.npr.org/2023/02/24/1159286436/ai-chatbot-chatgpt-magazine-clarkesworld-artificial-intelligence>
- Chen, M. Y., Lughofer, E., Rubio, J. J., & Wu, Y. J. (2021). Editorial: Anticipatory systems: Humans meet artificial intelligence. *Frontiers in Psychology*, 12, 721879.
- Conway, M. (1988). *Theoretical Approaches to the Study of Roles* (2nd ed.). Appleton and Lange.
- Chen, M. (2023, January 24). Artists and Illustrators Are Suing Three A.I. Art Generators for Scraping and 'Collaging' Their Work Without Consent. *Artnet*. Retrieved on September 8, 2023, from <https://news.artnet.com/art-world/class-action-lawsuit-ai-generators-deviantart-midjourney-stable-diffusion-2246770>
- Chesterman, S. (2023). AI-Generated Content is Taking over the World. But Who Owns it? *NUS Law Working Paper No 2023/002*.
- Deltorn, J.-M., & Macrez, F. (2018). Authorship In The Age Of Machine Learning And Artificial Intelligence. In S. M. O'Connor (Ed.), *The Oxford Handbook of Music Law and Policy*. Oxford University Press, 2019.
- Denicola, R. C. (2016). Ex Machina: Copyright Protection for Computer Generated Works. *69 Rutgers UL Rev.*, 251.
- Dysart, J. (2018, July 3). Give me that AI Rock and Roll. *Communications of the ACM*. Retrieved on September 6, 2023, from <https://cacm.acm.org/news/229159-give-me-that-ai-rock-and-roll/fulltext>
- Eisikovits, N., & Stubbs, A. (2023, January 12). ChatGPT, DALL-E 2 and the collapse of the creative process. *The Conversation*. Retrieved on September 8, 2023, from <https://theconversation.com/chatgpt-dall-e-2-and-the-collapse-of-the-creative-process-196461>
- Farina, M., & Lavazza, A. (2023). ChatGPT in society: emerging issues. *Frontiers in Artificial Intelligence*, 6. <https://doi.org/10.3389/frai.2023.1130913>
- Garfinkle, A. (2023, February 3). ChatGPT on track to surpass 100 million users faster than TikTok or Instagram: UBS. *Yahoo Finance*. Retrieved on September 5, 2023, from <https://finance.yahoo.com/news/chatgpt-on-track-to-surpass-100-million-users-faster-than-tiktok-or-instagram-ubs-214423357.html>
- George, A. S., George, A. H., & Martin, A. G. (2023, January 1). A Review of ChatGPT AI's Impact on Several Business Sectors. *Partners Univers. Int. Innov. J.*
- Gleason, N. W. (2023, April 3). Disrupting higher education – ChatGPT and generative AI. *The European Business Review*. Retrieved on September 5, 2023, from <https://www.europeanbusinessreview.com/disrupting-higher-education-chatgpt-and-generative-ai/>
- Holden Thorp, H. (2023). ChatGPT is fun, but not an author. *Science*, 379(313), 313. DOI:10.1126/science.adg7879
- IBM. (2011, September 13). IBM's 100 Icons of Progress. Retrieved on September 5, 2023, from <https://www.ibm.com/ibm/history/ibm100/us/en/icons/deepblue/>

- Jabotinsky, H. Y., & Sarel, R. (2023). Co-authoring with an AI? Ethical Dilemmas and Artificial Intelligence. Available at SSRN: <https://ssrn.com/abstract=4303959> or <http://dx.doi.org/10.2139/ssrn.4303959>
- Jha, N., Lee, K. S., & Kim, Y. J. (2022). Diagnosis of temporomandibular disorders using artificial intelligence technologies: A systematic review and meta-analysis. *PLoS One*, 17(8), e0272715.
- Landa-Blanco, M., Flores, M. A., & Mercado, M. (2023, March 8). Human vs. AI Authorship: Does it Matter in Evaluating Creative Writing? A Pilot Study Using ChatGPT. <https://doi.org/10.31234/osf.io/wjism3>
- Lin, H. Y. (2023). Standing on the Shoulders of AI Giants. *Computer*, 56(01), 97-101. <https://doi.org/10.1109/MC.2022.3218176>.
- Lu, B. (2021). A Theory of 'Authorship Transfer' and Its Application to the Context of Artificial Intelligence Creations. *Queen Mary Journal of Intellectual Property*, 11(1).
- Lucey, B., & Dowling, M. (2023, January 26). ChatGPT: our study shows AI can produce academic papers good enough for journals – just as some ban it. *The Conversation*. Retrieved on September 6, 2023, from <https://theconversation.com/chatgpt-our-study-shows-ai-can-produce-academic-papers-good-enough-for-journals-just-as-some-ban-it-197762>
- Murphy, B. P. (2023, February 27). Is there a way to pay content creators whose work is used to train AI? Yes, but it's not foolproof. *The Conversation*. Accessed on September 30, 2023, from <https://theconversation.com/is-there-a-way-to-pay-content-creators-whose-work-is-used-to-train-ai-yes-but-its-not-foolproof-199882>
- Narasimhan, S. (2023, September 9). Optimizing Vendor Management: Harnessing the Power of LLMs and Knowledge Graphs. *Medium*. Retrieved September 28, 2023, from <https://medium.com/nerd-for-tech/optimizing-vendor-management-harnessing-the-power-of-llms-and-knowledge-graphs-13a6b8b36a01>
- Nolan, B. (2023). More than 200 books in Amazon's bookstore have ChatGPT listed as an author or coauthor. *Business Insider*. Retrieved on September 5, 2023, from <https://www.businessinsider.com/chatgpt-ai-write-author-200-books-amazon-2023-2>
- OpenAI. (2022, September 2). About OpenAI. *OpenAI*. Retrieved on September 5, 2023, from <https://openai.com/about/>
- Padmanabhan, A., & Wadsworth, T. (2023, April 19). A Common Law Theory of Ownership for AI-Created Properties. Retrieved on September 7, 2023, from <https://ssrn.com/abstract=4411194>
- Philipps, A., & Mrowczynski, R. (2021). Getting more out of interviews. Understanding interviewees' accounts in relation to their frames of orientation. *Qualitative Research*, 21(1), 59–75. <https://doi.org/10.1177/1468794119867548>
- Polonsky, M. J., & Rotman, J. D. (2023). Should Artificial Intelligent Agents be Your Co-author? Arguments in Favour, Informed by ChatGPT. In *Australasian Marketing Journal (Vol. 31, Issue 2, pp. 91–96)*. SAGE Publications Ltd. <https://doi.org/10.1177/14413582231167882>
- Rivas, P., & Zhao, L. (2023). Marketing with ChatGPT: Navigating the Ethical Terrain of GPT-Based Chatbot Technology. *AI*, 4(2), 375–384. <https://doi.org/10.3390/ai4020019>
- Schuler, R. S., Aldag, R. J., & Brief, A. P. (1977). Role conflict and ambiguity: A scale analysis. *Organ. Behav. Hum. Perform.*, 20, 111–128.
- Schwitzgebel, E., Schwitzgebel, D., & Strasser, A. (2023). Creating a Large Language Model of a Philosopher. Available online at: <https://arxiv.org/abs/2302.01339>
- Stokel-Walker, C. (2023). ChatGPT listed as author on research papers: many scientists disapprove. *Nature*, 613, 620-621. doi: <https://doi.org/10.1038/d41586-023-00107-z>
- Sun, J., Xu, C., Tang, L., Wang, S., Lin, C., Gong, Y., Shum, H.-Y., & Guo, J. (2023). Think-on-Graph: Deep and Responsible Reasoning of Large Language Model with Knowledge Graph. <http://arxiv.org/abs/2307.07697>
- Taylor, S., Cairns, A., Glass, B. (2020). Role Theory: A Framework to Explore Health Professional Perceptions of Expanding Rural Community Pharmacists' Role. *Pharmacy (Basel)*, 8(3), 161. doi: 10.3390/pharmacy8030161. PMID: 32887322; PMCID: PMC7559310.
- Ueda, K., & Yamada, Y. (2023, February 16). ChatGPT is not an author, but then, who is eligible for authorship? <https://doi.org/10.31234/osf.io/h5aj3>
- Varanasi, L. (2023, April 24). These are the 12 best books to get up to speed on the hot new world of generative AI, according to experts. *Business Insider*. Retrieved on September 6, 2023, from <https://www.businessinsider.com/list-generative-ai-artificial-intelligence-best-books-for-learning-experts-2023-3#improptu-amplifying-our-humanity-through-ai-1>
- Vincent, J. (2019, January 25). Retrieved on September 5, 2023, from <https://www.theverge.com/2019/1/24/18196135/google-deepmind-ai-starcraft-2-victory>
- Wölker, A., & Powell, T. E. (2021). Algorithms in the newsroom? News readers' perceived credibility and selection of automated journalism. *Journalism*, 22, 86–103. doi: 10.1177/1464884918757072
- Xie, W. (2023, May 14). AI Inventorship: Will Our Patent Laws Stand Up? My Conversation with Dr. Stephen Thaler. *IPWatchdog*. Retrieved on September 8, 2023, from <https://ipwatchdog.com/2023/05/14/ai-inventorship-will-patent-laws-stand-conversation-dr-stephen-thaler/id=160832/>
- Yang, L., Chen, H., Li, Z., Ding, X., & Wu, X. (2023). ChatGPT is Not Enough: Enhancing Large Language Models with Knowledge Graphs for Fact-aware Language Modeling. <http://arxiv.org/abs/2306.11489>

## **Distinguishing Game Engagement from Task Engagement in the Gamification of e-Commerce Platforms: An Empirical Study of Shopping Festival Games**

Nan Wang <sup>1</sup>  
Yuxing Peng <sup>2,\*</sup>

\*Corresponding author

<sup>1</sup> Associated Professor, Wuhan University, Wuhan, China, nanwang@whu.edu.cn

<sup>2</sup> Postgraduate, Wuhan University, Wuhan, China, 2019302170019@whu.edu.cn

### **ABSTRACT**

Although gamification has been widely used in e-commerce platforms, research on gamification in marketing is still scarce compared to practice, and the impact of gamification on purchase intention remains to be clarified. Therefore, based on affordance theory and engagement theory, this paper establishes a theoretical model to explain the pathway of gamification's effects. Specifically, this study takes the e-commerce shopping festival game as an example, distinguishes the game part and task part, explores the relationship between them, and identifies the different mechanisms of the two parts' engagement on purchase intention. A survey was conducted, and 234 valid questionnaires were collected. Results showed that game part affordance positively affects game part engagement which could increase task engagement. Second, game part engagement and task part engagement impact purchase intention differently. Task part engagement has a direct impact on purchase intention, while game part engagement influences purchase intention through game intention. Finally, the contribution of theory and practice is discussed.

*Keywords:* Game affordance, e-commerce, game part engagement, task part engagement, purchase intention.

### **INTRODUCTION**

Gamification is using game elements in non-game contexts (Deterding, 2011), a process that supports users' overall value creation to enhance service with gameful experiences (Huotari & Hamari, 2012). In recent years, gamification has been widely used in education, health, marketing and other fields (Hamari et al., 2014). According to the latest 'Global Game Market Report' released by Newzoo, nearly 3.38 billion people are expected to play games in 2023. The mobile game market reached \$ 92.6 billion, with the Asia-Pacific region leading the global market with \$ 85.8 billion. The Net generation who grew up in the internet environment is more eager to have fun, challenge and socialize, often regarding playing games as the top priority in the action list.

Various e-commerce platforms have noticed the trend of gamification, and aware of the attractiveness of gaming products to users, they have begun to try implanting all kinds of gamification elements into their platforms to achieve the goal of increasing user stickiness (Koivisto & Hamari, 2019). Gartner, a well-known market research institution, predicted that gamified information systems and services will become an essential approach for marketing and user retention. However, gamification has been regarded by many enterprises as a mere element of the points system and has yet to be deeply understood and well applied. As reported by Gartner, more than 80% of gamification systems are doomed to failure due to a lack of understanding of gamification design.

In the transformation of research focus from information systems utilitarian value to hedonic value, the study of gamification has aroused widespread concern in academia (Deterding, 2011). Academia has yet to reach a unified understanding of gamification. However, there is a common perception that gamification should be combined with system design and user experience to engage and change user behavior. Current research on gamification has focused on education (Lee & Hammer, 2011), health (Hamari & Koivisto, 2013), work (Suh et al., 2017), marketing management (Huotari & Hamari, 2017; Xi & Hamari, 2019). In the field of gamified marketing, Deterding (2011) argued that when gamification is implemented in online marketing, the goal is to achieve value creation and enhance user loyalty by building positive consumer relationships, which in turn positively affects consumer purchasing behavior (Deterding, 2011). Hamari (2017) found that including a badge game element encouraged the college student population to trade more (Hamari, 2017), and badge elements can drive impulse buying. A gamification field experiment demonstrated that gamification has a significant impact on shopping activity in terms of boosting sales and increasing shop browsing, and that this impact of gamification is sustained.

Previous studies in the marketing field on gamification have several research gaps. Firstly, despite mounting evidence advocating

the effectiveness of gamification, it is still unclear what underlying mechanisms drive users to make purchase decisions as expected. Second, most previous literature treats gamification design as a whole. However, gamification design can be divided into two distinct parts: the game part which involves a game for users to play, and the task part which requires consumers to do tasks to get credit for the game part, such as a task that asks the consumer to browse the online shops for 15 seconds to get credit (Liu et al., 2017). Less attention has been paid to the distinct characteristics of these two parts and their relationship. Third, these two distinct parts will affect consumers' purchase behaviors differently. However, it is unclear about the mechanism of how these two parts impact purchase intention. To summarize, our study aims to answer two research questions:

RQ1: From the perspective of game affordance, why do users play games on e-commerce platforms, and further, what drives users to buy?

RQ2: What is the relationship between the game part and the task part, and how do these two parts generate influence on purchase intention?

To address these research questions, we take shopping festival games as examples. Considering the model of the shopping festival game in e-commerce and the correlation between each part of the game and shopping, we discuss the game part and the task part separately, and demonstrate the influence of the engagement of the two parts of the game on the overall use of the game and the purchase intention.

## LITERATURE REVIEW

### Gamification

Gamification was first introduced in 2002 by British engineer Nick Pelling, who applied gamification design to the field of commercial electronic devices. Gamification is generally defined as the application of game design elements to non-game context (Deterding, 2011), most scholars have accepted this definition, but it is relatively broad. Other scholars have supplemented and developed the definition of gamification, which has been put forward in different research perspectives and backgrounds. Gamification is the integration of game design elements and the target system, while maintaining the target system's instrumental function in the information system perspective (Liu et al., 2017). In service marketing, gamification is the integration of brand applications and game design elements to increase customer value and create more purchases and loyalty (Hofacker et al., 2016), is a service process that enhances the user's game experience to support the user's overall value creation (Huotari & Hamari, 2012). Since the DICE Summit 2010, gamification has become popular and gradually penetrated all fields, such as health, education, work, marketing, and has been used to good effect to enable behavior change and intervention (Yang & Gottlieb, 2023). An empirical study of the application of gamification in health and exercise found that people's willingness to ride increased when they were able to share and display gamified badges to others (Sheffler et al., 2020); Well-designed gamification can stimulate structural competitiveness for engagement and achievement growth (Amo et al., 2020), also enable to increase knowledge sharing (Holzer et al., 2020); A gamified IS in the workplace engages users and promotes their continued system use (Suh et al., 2017).

The application of gamification in e-commerce platforms is mainly through specific gamification elements. The typical game elements are points, badges, and leaderboards, also known as PBL, which form a "funware loop" (Zichermann & Linder, 2010). Many scholars have put forward opinions on how to classify gamification elements, and in the early days, scholars used the classification method in the field of game theory to classify gamification elements in non-game contexts. Hunicke et al. (2004) proposed the MDA framework, one of the widely used frameworks in the game industry, to classify and explain game design elements from three dimensions: mechanism, dynamics and aesthetics (Hunicke et al., 2004). Werbach (2012) proposed the DMC system according to the role in the gamification framework, the gamification elements are divided into three categories: dynamics, mechanism and component (Werbach et al., 2012). In this study, according to Koivisto and combined with the characteristics of shopping festival games in e-commerce platforms, we classify the gamification elements into achievement, social, immersion three categories (Koivisto & Hamari, 2019).

Gamification leverages people's desires for competition, achievement, status, self-expression, altruism, and closure (Taskiran & Yilmaz, 2015). People believe gamification is helpful because the game's design elements are integrated into the non-game context, so the user feels the game experience (Deterding, 2011). Gamification can invoke emotional and cognitive reactions like flow experience and aesthetic experience (Suh et al., 2017). In marketing, gamification has been found to have a significant impact on consumer shopping participation (Ho et al., 2023), which can improve the experience value and drive users into marketing activities (Sigala, 2015). In the online shopping context, gamification can serve as a stimulating factor affecting individual shopping intentions and produce positive shopping emotions and shopping behaviors (Ho et al., 2023; Xu et al., 2020), bringing more transactions and impulse buying (Hamari, 2017). Considering the form of gamification in e-commerce platforms, exploring the relationship between games and shopping is a challenge. In this regard, this paper takes shopping festival games as an example of gamification and supplements the literature by distinguishing the game part from the task part.

### Affordance Theory

Affordance theory originated in the field of ecology. The affordances of the environment are what it offers the animal and what

it provides or furnishes (Gibson, 1978). Affordance refers to both perceived and actual properties of the thing, primarily those fundamental properties that determine just how the thing could possibly be used, and Norman believed that perceived affordance plays a more significant role (Norman, 1988). Therefore, affordance is formed by the relationship between users and technical characteristics (Dong & Wang, 2018). The affordance is not the nature of the object (Lankton et al., 2015) but the possibility of action brought about by the attributes of the object or object (Markus & Silver, 2008). In brief, affordance indicates the possibility of behavior. When perceived, affordance allows actors to take actions that may satisfy specific needs (Ping, 2008).

Previous studies have applied affordance in various fields to understand the interaction between the individual and the surrounding environment (Shi et al., 2022). In gamification systems, affordance refers to the elements and mechanics that structure games and aid in inducing gameful experiences (Koivisto & Hamari, 2019). The implementations of gamification varied between studies depending on what game-like motivational affordances had been implemented (Koivisto & Hamari, 2019). Affordance can better help to understand users' psychological state and behavior in social business activities, especially for understanding their participation.

A literature review identified three gamification affordances commonly implemented in an IS that use game elements: achievement, social, and immersion (Koivisto & Hamari, 2019; Yee, 2006). Achievement affordance enables users to perceive what the gamified IS allows them to receive rewards as a payoff when they complete predesigned tasks (Hamari et al., 2014). Gamification elements like points, grades, badges and rewards can provide players with achievement affordance (Zagal et al., 2005). Social affordance can provide users with a stronger feeling of connectedness and belonging due to high-frequency communication and reciprocity (Francisco-Aparicio et al., 2013; Xi & Hamari, 2019), including social networking features, cooperation and teams. Immersion affordance is primarily making the player immersed in the self-directed inquisitive activity, and induces higher psychological investment in autonomous thinking, avatar, character, narration may allow players to feel this type of affordance (Kim et al., 2015; Koivisto & Hamari, 2019). These three affordances make up what shopping festival games in e-commerce platforms can offer players, so in this study, we measure game part affordance in terms of these three dimensions.

### **Engagement Theory**

Engagement is a psychological state that was first used in psychology. It refers to adaptability or compatibility between two or more things. Later, engagement began to be used to express an emotional involvement, participation, connection or even attachment. Appelbaum (2001) proposed that customers' engagement in marketing was composed of rational loyalty and emotional attachment, and put forward corresponding theoretical guidance for marketing practice (Appelbaum & Alec, 2001). Extensive research on engagement has gradually become the focus of marketing research, and has been extended to develop emerging concepts like "consumer engagement" and "customer engagement".

Customer engagement is the degree of relationship between customers and service organizations in terms of cognition and emotion, is a multi-dimensional concept of cognition, emotion and behavior (Brodie et al., 2011). Hollebeek (2011) also defined customer brand engagement from a comprehensive perspective as customers' brand-related cognitive, situational-dependent mental states and behavioral activities to some extent in the interaction with the brand. Ashley (2015) pointed out that in the Internet platform, marketing practitioners carry out content marketing through customer engagement (Ashley & Tuten, 2015). Referring to Hollebeek's definition of consumer engagement and integrating the relevant theories of the e-commerce platform (Hollebeek, 2011), consumer engagement from the perspective of the e-commerce platform is defined as follows: E-commerce platform users voluntarily and actively participate in platform activities, and the intensity of interaction between users and between users and platforms in the process of participation. This research divides consumer engagement into game part engagement and task part engagement. Game part engagement refers to the user's voluntary and active participation in the game part of the platform game; task part engagement refers to the interaction intensity of the user's voluntary and active participation in the task part of the platform game.

The dimension of Customer engagement is divided into single-dimensional and multi-dimensional perspectives. With the deepening research, consumer engagement is and more specific through multi-dimensional perspectives. Hollebeek (2011) believes that customer engagement is a brand-related and motivation-driven psychological state formed by consumers in interacting with the enterprise. It is divided into three levels: immersion, enthusiasm and activation, which correspond to customer cognition, emotion and behavior in interacting with the brand (Hollebeek, 2011). Brodie et al. (2011) consider customer engagement as a multi-dimensional concept encompassing cognitive, affective, and behavioral dimensions, and is a psychological state related to focus objects and situations generated by customers through interaction with focus objects and co-creation of customer experience (Brodie et al., 2011). Vivek (2009) proposed that customer engagement reflects the intensity of participation and connection between individuals and organizations from three dimensions: conscious participation, enthusiasm and social interaction, which correspond to cognition, emotion and behavior respectively (Vivek, 2009).

In previous studies, the division of customer engagement is still based on three-dimensional customer engagement as the



mainstream research. This division method is mature and convenient for empirical research. Based on the literature review and the research background of gamification e-commerce platforms, our study comprehensively refers to Cheung et al.'s dimension of customer engagement, dividing it into three aspects: Vigor, Absorption and Dedication (Cheung et al., 2011).

### REASERCH MODEL AND HYPOTHESE DEVELOPMENT

Figure 1 exhibits our research framework, and the hypotheses are formulated as follows.

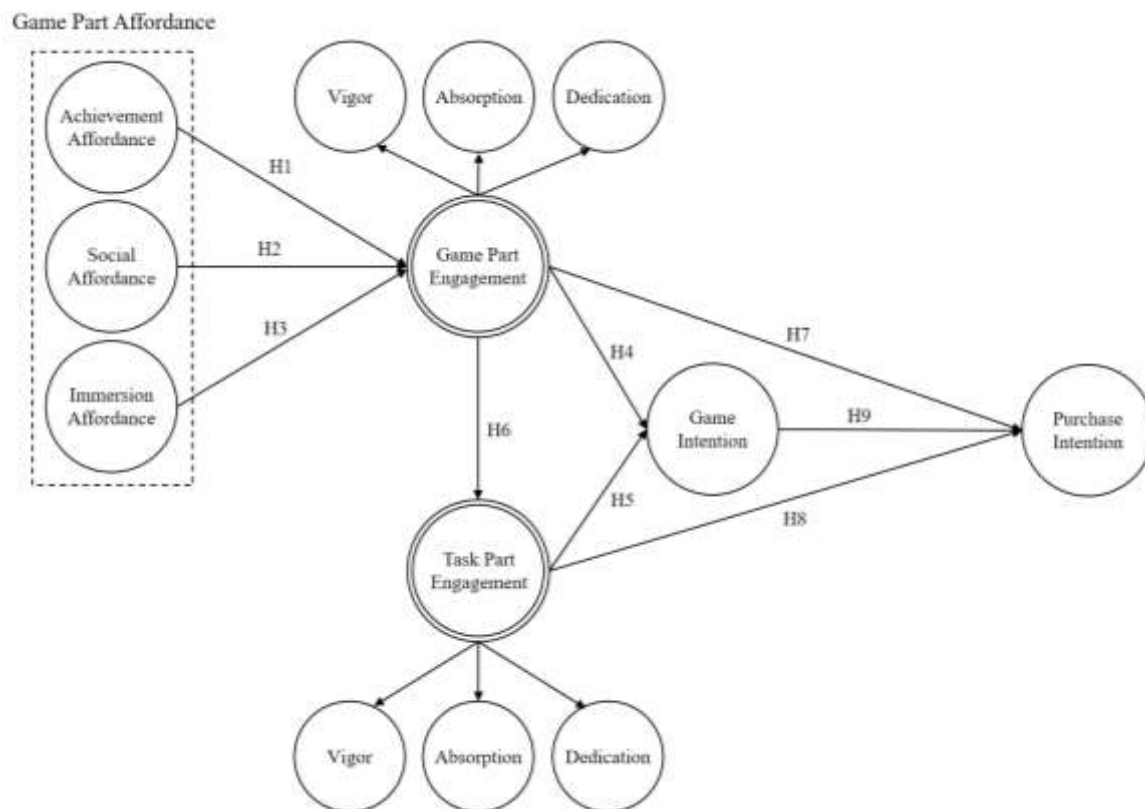

Figure 1: Research Model

#### Game Part Affordance, Game Part Engagement and Task Part Engagement

Successfully conveying affordances induced by game elements is necessary for designing an engaging IS. In the context of virtual interactive services, the interaction between customers and elements has a positive effect on customer engagement. Interaction in online virtual communities will positively affect customer engagement, and the impact of this interaction on customer engagement also appears in online game scenarios (Cheung et al., 2015). Previous studies have shown that interactivity can significantly affect customers' immersion and presence, which is an important part of customer engagement. An extensive literature review identified three affordances (achievement, social, immersion) in shopping festival games and speculated that they might increase customer engagement.

In psychology, people naturally tend to solve challenges and develop personal skills. The achievement game elements clearly show their achievements, set user goals and bring timely feedback. Users expect to improve and perform better in the game, so using achievement elements can improve users' motivation and engagement (Bormann & Greitemeyer, 2015). In the context of this study, users can get prizes by playing shopping festival games, such as getting points and coupons that can be used in shopping, and they can feel the functional value of the game and improve customer engagement. Therefore, we put forward the hypothesis:

H1: Achievement affordance positively affects game part engagement.

Cooperation, social networks and other elements in games that bring social affordance will enhance the users' inner pleasure by bringing a sense of immersive experience (Deterding, 2014). Competition can create an entertaining atmosphere by stimulating users' specific task commitments so that users tend to use social game elements to interact with other users (Conaway & Garay, 2014). In the shopping festival game, players maintain or build new relationships with other players by conveying social affordance, in which the sense of pleasure leads to game part engagement. Therefore, we put forward the hypothesis:

H2: Social affordance positively affects game part engagement.

Users interact with immersive gamification elements such as virtual images, role-playing mechanisms, and narratives, which can generate immersion affordance. In this process, it can arouse users' curiosity, make them experience a higher sense of freedom and fluency (Hamari & Koivisto, 2014), and lead users to participate more. In shopping festival games, the immersion brought about by the game's storyline and plot can increase player engagement. Therefore, we put forward the hypothesis:

H3: Immersion affordance positively affects game part engagement.

#### **Game Part Engagement, Task Part Engagement and Game Intention**

In this study, customer engagement refers to users voluntarily and actively participating in shopping festival games and the intensity of interaction (Hollebeek, 2011). Customer engagement plays a vital role in marketing research and is considered an important driving force for consumer behavior research. Hollebeek (2014) considered that customer brand engagement will increase usage intention (Hollebeek et al., 2014). Brodie et al. (2011) believed that user participation and involvement result from the customer engagement process (Brodie et al., 2011). Based on the study by Liu, Santhanam et al. (2017), this study divides customer engagement into game and task part engagement in shopping festival games. The degree of engagement affects users' emotional and cognitive investment in shopping festival games, so it can change the propensity to play. Therefore, we put forward the hypothesis:

H4: Game part engagement positively affects game intention.

H5: Task part engagement positively affects game intention.

The affect transfer model pointed out that the psychological reactions caused by the media will affect the advertising attitude in the same direction (Cantor et al., 1974). The game and task parts together form the shopping festival game on the e-commerce platform. In this context, the sense of participation gained in the game part will be transferred to the task part because of its relevance. Therefore, we put forward the hypothesis:

H6: Game part engagement positively affects task part engagement.

#### **Game Part Engagement, Task Part Engagement and Purchase Intention**

Previous studies have shown that customer engagement will lead to purchasing results, both customer purchase intention and purchase behavior. Several studies have proved that customer engagement can effectively promote purchase behavior. In online games, customers' psychological and behavioral engagement will promote customers' money spent on online games (Cheung et al., 2015). When engaging in shopping festival games, players can better understand the reward rules as well as the product information, thus making them more closely related to the products. Therefore, we put forward the hypothesis:

H7: Game part engagement positively affects purchase intention.

H8: Task part engagement positively affects purchase intention.

#### **Game Intention and Purchase Intention**

Gamification services can trigger psychological reactions, thereby stimulating specific behavioral outcomes. These results include attitudes, engagement, and buying or repurchasing behavior from a marketing perspective. Some scholars suggest using gamification to influence users' purchase decisions. In shopping festival games, the purchase behavior will be affected by the game challenges. These gamification designs encourage users to make purchases (Hildebrand et al., 2014). Feng et al. (2020) pointed out that consumers with game experience are more willing to buy (Feng et al., 2020). Previous studies have shown a positive correlation between game use and marketing results. We contend that users who play shopping festival games on e-commerce platforms are more likely to make purchases. Therefore, we put forward the hypothesis:

H9: Game intention positively affects purchase intention.

## **RESEARCH METHODOLOGY**

### **Instrument Development**

We adapted measurements of constructs from the existing research to ensure validity and reliability. All the constructs were measured using a 5-point Likert scale (with 1 = strongly disagree to 5 = strongly agree). Table 1 presents the measurement items and literature sources. The measure of game part affordance was divided into three dimensions: achievement affordance (ACH), social affordance (SOC) and immersion affordance (IMM), which were derived from existing scales for measuring game part affordance (Lee et al., 2021; Suh et al., 2017). We adapted an existing scale to measure game part engagement (GE) and task

part engagement (TE) from Cheung, and took engagement as a second-order variable measured by absorption (A), vigor (V) and dedication (D) (Cheung et al., 2011). The measure of game intention (GI) and purchase intention (PI) was adapted according to Grewal (Grewal et al., 1998). To promote respondents' understanding of gamification, a design example of a game on the e-commerce platform during the shopping festival was presented at the beginning of the survey as shown in Figure 2. The measurements were translated from English to Chinese and then back to English using anti-translation techniques. And ensure the consistency of meaning.

Table 1: Constructs and Measures

Constructs	Dimension	Measures	References
Game Part Affordance	Achievement Affordance	Playing game part on the e-commerce platform during the shopping festival offers me the possibility to: 1. obtain rewards as achievements of my participation. 2. achieve good performance and receive rewards. 3. obtain more rewards if I try harder.	Suh, A., et al. (2017)
	Social Affordance	Playing game part on the e-commerce platform during the shopping festival offers me the possibility to: 1. communicate with other players in the game part. 2. become part of a guild in the game part. 3. team up with other players in the game part. 4. keep in touch with other players in the game part.	Lee, Z. W. Y., et al. (2021)
	Immersion Affordance	Playing game part on the e-commerce platform during the shopping festival offers me the possibility to: 1. put myself into the game part role. 2. immerse myself in the game part. 3. explore the world in the game part. 4. create the appearance and background of my character in the game part.	
Game Part Engagement	Vigor	1. I can continue playing the game part in shopping festival games for very long periods at a time. 2. I feel strong and vigorous when I am playing the game part in shopping festival game. 3. I devote a lot of energy to the game part in shopping festival game.	Cheung et al. (2011)
	Absorption	1. I am rarely distracted when playing the game part in shopping festival game. 2. My mind is focused when playing the game part in shopping festival game. 3. I pay a lot of attention to the game part in shopping festival game.	
	Dedication	1. I am enthusiastic in the game part in shopping festival game. 2. I am excited when playing the game part in shopping festival game. 3. I am interested in the game part in shopping festival game.	
Task Part Engagement	Vigor	1. I can continue doing task part in shopping festival game for very long periods at a time. 2. I feel strong and vigorous when I am doing task part in shopping festival game. 3. I devote a lot of energy to the task part in shopping festival game.	Cheung et al. (2011)
	Absorption	1. I am rarely distracted when doing task part in shopping festival game. 2. My mind is focused when doing task part in shopping festival game. 3. I pay a lot of attention to the task part in shopping festival game.	
	Dedication	1. I am enthusiastic in the task part in shopping festival game. 2. I am excited when doing task part in shopping festival game. 3. I am interested in the task part in shopping festival game.	
Game Intention	/	During the shopping festival: 1. I would play game in e-commerce platform. 2. I would consider playing game in e-commerce platform. 3. The probability that I would play game in e-commerce platform is high.	Grewal et al. (1998)
Purchase Intention	/	During the shopping festival, after completing the shopping task in the game: 1. I would purchase in this e-commerce platform. 2. I would consider buying in this e-commerce platform. 3. The probability that I would consider buying in this e-commerce platform is high.	Grewal et al. (1998)

Source: This study.

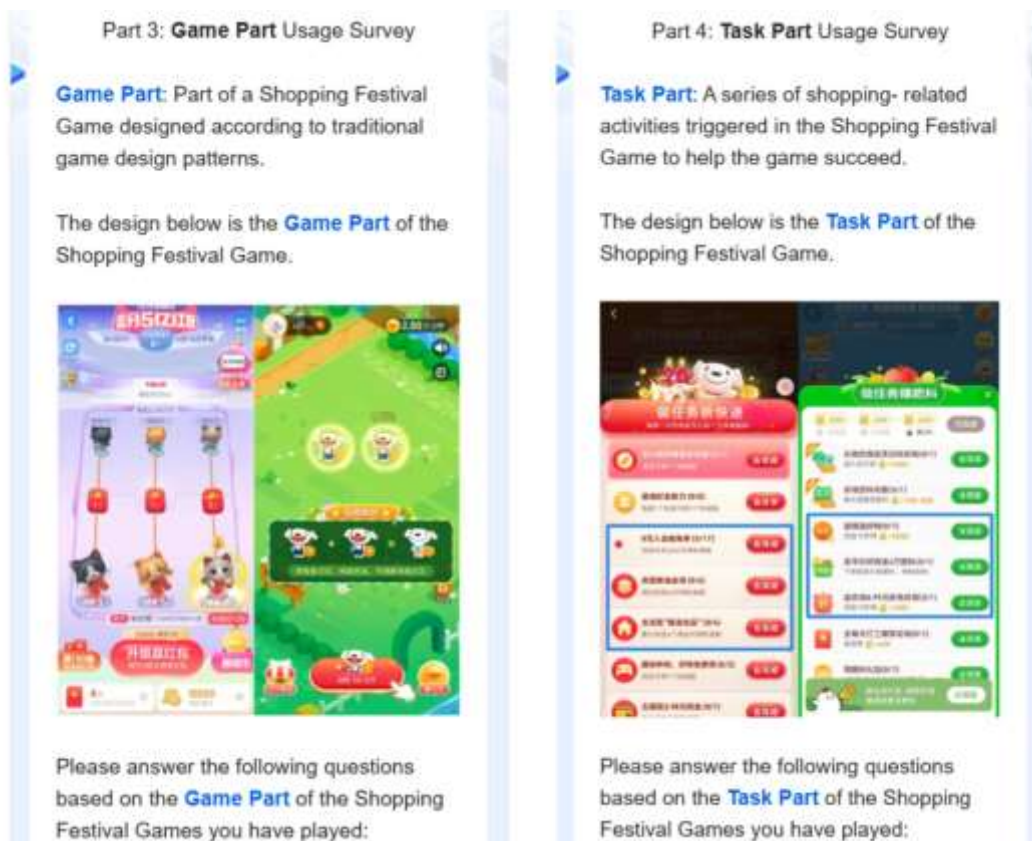

Source: This study.

Figure 2: Questionnaire Design

**Data Collection**

This research mainly focuses on the impact of shopping festival games on consumers' purchase intention on e-commerce platforms. China's major gamification e-commerce platforms, such as Taobao, Tmall and Jingdong, are investigated as the main platforms. This study takes consumers participating in shopping festival games on the shopping platform as the research subjects. The screening question in the survey ensures that our respondents have had the experience of playing games on the e-commerce platform during the shopping festival. "Questionnaire star" online platform was used to design and disseminate our questionnaires. We distributed questionnaires through Douban, Sina Weibo, WeChat, QQ and other social platforms, shortly after the '618 Shopping Festival' in 2023. A total of 265 questionnaires were collected and 234 valid questionnaires were obtained after screening. Table 2 shows the demographics of the valid respondents.

Table 2: Demographics

Variables	Category	Frequency	Percentage (%)
Gender	Male	80	34.2
	Female	154	65.8
Age(years)	<20	46	19.7
	21-30	174	74.4
	31-40	8	3.4
	41-65	6	2.6
Education	Senior	33	14.1
	Undergraduate	131	56.0
	Postgraduate	70	29.9
Monthly platform consumption	<200 yuan	37	15.8
	200-500 yuan	112	47.9
	500-1000 yuan	61	26.1
	> 1000 yuan	24	10.3

Source: This study.

## DATA ANALYSIS RESULTS

### Measurement Model Analysis

To examine the measurement model following criteria suggested by previous studies, we used SmartPLS 3.0 to evaluate its reliability and validity (Hair et al., 2011). Table 3 and Table 4 shows the Cronbach's Alpha (CA), Composite Reliability (CR), Average Variance Extracted (AVE) and Factor Loading. The results showed that all constructs' CA value (ranging from 0.736 to 0.892) and CR value (ranging from 0.85 to 0.933) were greater than 0.7. The AVE value (ranging from 0.654 to 0.823) of all constructs was above 0.5, demonstrating satisfactory reliability and convergent validity.

Table 3: The First-Order Reflect Reliability and Convergent Validity

Constructs	CA	CR	AVE	Factor Loading
Achievement Affordance (ACH)	0.736	0.85	0.654	0.792 0.828 0.805
Social Affordance (SOC)	0.837	0.891	0.672	0.824 0.755 0.838 0.858
Immersion Affordance (IMM)	0.862	0.906	0.708	0.881 0.856 0.857 0.767
Game Part Absorption (GA)	0.865	0.918	0.788	0.913 0.889 0.861
Game Part Dedication (GD)	0.889	0.931	0.818	0.916 0.892 0.906
Game Part Vigor (GV)	0.836	0.902	0.754	0.909 0.864 0.829
Task Part Absorption (TA)	0.892	0.933	0.823	0.919 0.907 0.895
Task Part Dedication (TD)	0.889	0.931	0.819	0.906 0.910 0.898
Task Part Vigor (TV)	0.851	0.91	0.771	0.910 0.878 0.846
Game Intention (GI)	0.852	0.91	0.771	0.890 0.860 0.885
Purchase Intention (PI)	0.826	0.896	0.742	0.873 0.841 0.869

Source: This study.

Table 4: The Second-Order Reflect Construct Reliability and Convergent Validity

Constructs	CA	CR	AVE	Factor Loading
<b>Game Part Engagement</b>	<b>0.927</b>	<b>0.925</b>	<b>0.805</b>	
Game Part Absorption				0.908
Game Part Dedication				0.869
Game Part Vigor				0.914
<b>Task Part Engagement</b>	<b>0.953</b>	<b>0.929</b>	<b>0.814</b>	

Task Part Absorption				0.911
Task Part Dedication				0.902
Task Part Vigor				0.894

Source: This study.

The results of factor loadings and cross-loadings analysis show that the loading of all measurement items on their theoretical latent variables is greater than 0.7 in Table 5, which also shows good convergent validity.

Table 5: Loadings and Cross Loadings

	ACH	SOC	IMM	GA	GD	GV	TA	TD	TV	GI	PI
ACH1	<b>0.774</b>	0.176	0.174	0.243	0.301	0.231	0.155	0.129	0.163	0.284	0.335
ACH2	<b>0.822</b>	0.173	0.229	0.263	0.295	0.322	0.22	0.18	0.213	0.331	0.32
ACH3	<b>0.828</b>	0.192	0.21	0.261	0.237	0.256	0.28	0.206	0.29	0.312	0.329
SOC1	0.098	<b>0.833</b>	0.54	0.288	0.356	0.293	0.398	0.401	0.391	0.274	0.287
SOC2	0.206	<b>0.748</b>	0.43	0.248	0.301	0.316	0.297	0.315	0.305	0.276	0.323
SOC3	0.224	<b>0.831</b>	0.41	0.31	0.314	0.293	0.299	0.326	0.325	0.288	0.323
SOC4	0.21	<b>0.862</b>	0.529	0.355	0.394	0.388	0.423	0.458	0.455	0.343	0.377
IMM1	0.178	0.501	<b>0.881</b>	0.473	0.507	0.497	0.442	0.437	0.455	0.369	0.349
IMM2	0.179	0.481	<b>0.854</b>	0.519	0.519	0.548	0.442	0.426	0.485	0.375	0.344
IMM3	0.264	0.461	<b>0.858</b>	0.464	0.531	0.463	0.457	0.417	0.466	0.402	0.367
IMM4	0.242	0.547	<b>0.769</b>	0.388	0.462	0.401	0.354	0.415	0.403	0.305	0.394
G-A1	0.256	0.328	0.503	<b>0.913</b>	0.667	0.602	0.597	0.536	0.507	0.44	0.312
G-A2	0.317	0.369	0.512	<b>0.889</b>	0.697	0.602	0.601	0.539	0.511	0.482	0.345
G-A3	0.27	0.287	0.451	<b>0.862</b>	0.655	0.613	0.583	0.498	0.577	0.43	0.382
G-D1	0.3	0.388	0.544	0.714	<b>0.916</b>	0.618	0.564	0.588	0.501	0.491	0.364
G-D2	0.288	0.375	0.517	0.697	<b>0.892</b>	0.604	0.568	0.602	0.508	0.537	0.41
G-D3	0.339	0.377	0.568	0.647	<b>0.906</b>	0.63	0.534	0.569	0.526	0.507	0.376
G-V1	0.25	0.361	0.54	0.625	0.623	<b>0.91</b>	0.499	0.489	0.567	0.465	0.333
G-V2	0.313	0.421	0.573	0.585	0.634	<b>0.864</b>	0.516	0.505	0.56	0.466	0.406
G-V3	0.315	0.243	0.36	0.564	0.514	<b>0.829</b>	0.408	0.35	0.447	0.353	0.281
T-A1	0.223	0.384	0.477	0.654	0.595	0.512	<b>0.919</b>	0.775	0.76	0.495	0.453
T-A2	0.265	0.419	0.444	0.614	0.569	0.491	<b>0.907</b>	0.812	0.761	0.517	0.499
T-A3	0.256	0.391	0.456	0.552	0.505	0.49	<b>0.895</b>	0.753	0.809	0.486	0.498
T-D1	0.143	0.443	0.462	0.545	0.601	0.482	0.811	<b>0.906</b>	0.76	0.5	0.471
T-D2	0.25	0.415	0.456	0.547	0.577	0.496	0.797	<b>0.91</b>	0.766	0.531	0.5
T-D3	0.189	0.404	0.448	0.51	0.58	0.431	0.726	<b>0.898</b>	0.765	0.549	0.465
T-V1	0.271	0.394	0.525	0.539	0.512	0.567	0.777	0.742	<b>0.91</b>	0.514	0.502
T-V2	0.179	0.414	0.487	0.521	0.532	0.549	0.736	0.776	<b>0.878</b>	0.51	0.498
T-V3	0.284	0.398	0.404	0.516	0.444	0.48	0.745	0.704	<b>0.846</b>	0.469	0.478
GI1	0.316	0.341	0.428	0.468	0.515	0.458	0.572	0.625	0.599	<b>0.89</b>	0.62
GI2	0.407	0.303	0.35	0.458	0.52	0.421	0.453	0.46	0.428	<b>0.86</b>	0.592
GI3	0.289	0.309	0.359	0.41	0.454	0.426	0.417	0.435	0.456	<b>0.885</b>	0.619
PI1	0.403	0.418	0.451	0.395	0.404	0.349	0.528	0.499	0.532	0.587	<b>0.873</b>
PI2	0.388	0.29	0.299	0.305	0.315	0.285	0.379	0.383	0.397	0.59	<b>0.841</b>
PI3	0.258	0.325	0.356	0.306	0.372	0.379	0.466	0.481	0.515	0.619	<b>0.869</b>

Source: This study.

According to Table 6, the square roots of AVE values of each construct were larger than their correlations with other constructs,

confirming the discriminant validity.

Table 6: Discriminant Validity

	REW	SOC	IMM	GA	GD	GV	TA	TD	TV	GI	PI
REW	<b>0.809</b>										
SOC	0.225	<b>0.82</b>									
IMM	0.253	0.585	<b>0.842</b>								
GA	0.316	0.37	0.551	<b>0.888</b>							
GD	0.345	0.42	0.6	0.758	<b>0.905</b>						
GV	0.336	0.397	0.571	0.682	0.682	<b>0.868</b>					
TA	0.269	0.437	0.506	0.669	0.614	0.548	<b>0.907</b>				
TD	0.212	0.463	0.503	0.591	0.648	0.519	0.86	<b>0.905</b>			
TV	0.273	0.456	0.539	0.598	0.566	0.607	0.857	0.844	<b>0.878</b>		
GI	0.383	0.362	0.433	0.508	0.565	0.496	0.551	0.582	0.567	<b>0.878</b>	
PI	0.405	0.401	0.429	0.39	0.423	0.393	0.533	0.529	0.561	0.695	<b>0.861</b>

Source: This study.

Structural Model Analysis

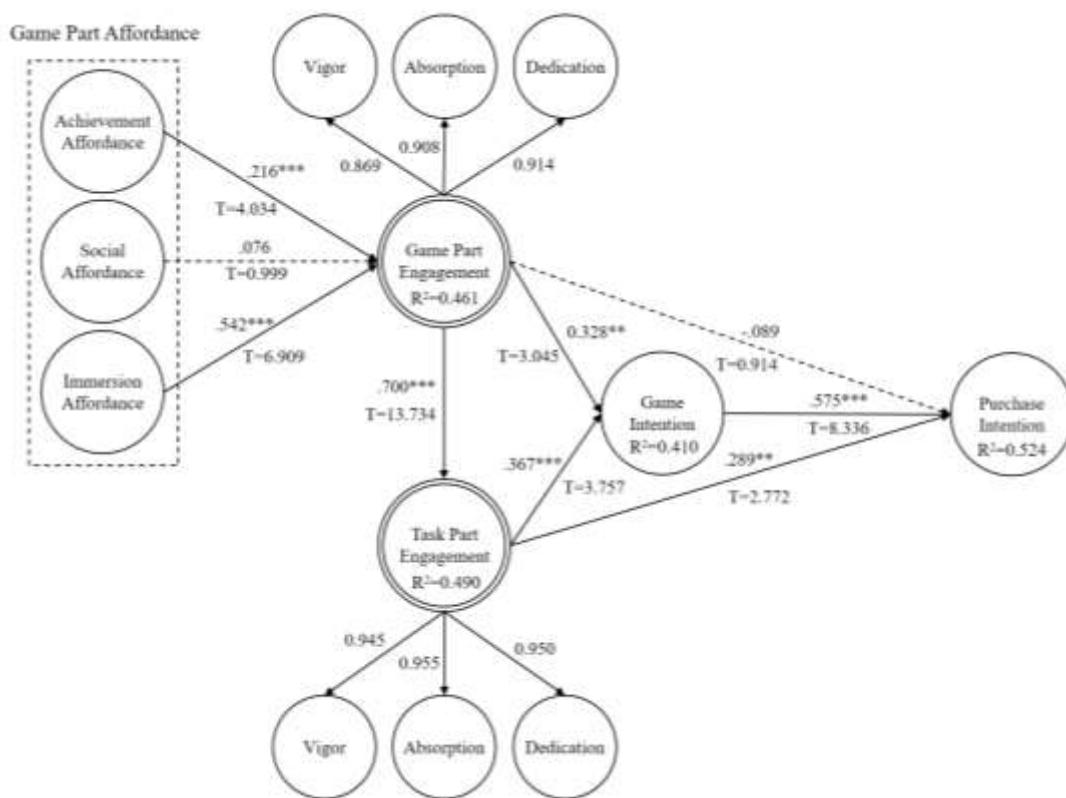

Source: This study.

Figure 3: Results of Hypotheses Testing

With an adequate measurement model, we utilized smartPLS3.0 to examine the structural model. The results are shown in Figure 3. The model explained 46.1 % of the variance of game part engagement, in which achievement affordance ( $\beta = 0.216$ ,  $T = 4.034$ ,  $p < 0.001$ ) and immersion affordance ( $\beta = 0.542$ ,  $T = 6.909$ ,  $p < 0.001$ ) significantly affected the variance of game part engagement, supporting H1 and H3. However, there was no significant effect between social affordance and game part engagement ( $\beta = 0.076$ ,  $T = 0.999$ ,  $p > 0.05$ ), thus rejecting H2. Regarding the relationship between the two parts of the shopping festival game, game part engagement has a positive effect on task part engagement ( $\beta = 0.700$ ,  $T = 13.734$ ,  $p < 0.001$ ), explaining 49.0% of the variance of task part engagement, suggesting that H4 was supported.



In addition, the analysis results show the impact of customer engagement on customer behavior, specifically as follows: (1) The model explained 41% of the difference in game intention, both game part engagement ( $\beta = 0.328$ ,  $T = 3.045$ ,  $p < 0.01$ ) and task part engagement ( $\beta = 0.367$ ,  $T = 3.757$ ,  $p < 0.001$ ) can significantly predict game intention, both H5 and H6 are confirmed. (2) Furthermore, the model explained 52.4% of the variance of purchase intention, task part engagement had a direct and significant impact on purchase intention ( $\beta = 0.542$ ,  $T = 6.909$ ,  $p < 0.001$ ), while game part engagement had no significant impact on purchase intention ( $\beta = 0.076$ ,  $T = 0.999$ ,  $p > 0.05$ ), H8 was supported and H7 was not supported. (3) In addition, the results show the positive impact of game intention on purchase intention ( $\beta = 0.575$ ,  $T = 8.336$ ,  $p < 0.001$ ), supporting H9.

## DISCUSSIONS AND IMPLICATIONS

### Discussions

Guided by affordance theory and engagement theory, this study built a model by taking shopping festival games as an example, solving two main problems in gamification:

The first one is why users play games on e-commerce platforms, and what drives users to buy. The results show that game part affordance positively influences game part engagement which could increase task part engagement. Both task part engagement and game part engagement could impact purchase intention. Specifically, among the three dimensions of game part affordance investigated in this study, immersion affordance and achievement affordance will positively affect game part engagement. Compared with achievement affordance ( $\beta = 0.216$ ), immersion affordance ( $\beta = 0.542$ ) will stimulate greater game part engagement. Surprisingly, the relationship between social affordance and game part engagement is not significant, this result exceeded our expected assumption. One possible reason could be that people buy online to avoid the social interaction necessary to buy in physical shops (Ozen & Engizek, 2014). Another possible reason could be that a shopping festival game is a kind of promotional game, players tend to pursue a utilitarian goal of financial reward rather than satisfy a need for sociability, utilitarian value has the greatest weight of influence on game intention (Yu & Huang, 2022). Players are more engaged because of the sense of achievement and immersion in the shopping festival game, and the willingness to socialize in it is not high. The possible reasons suggested above could explain the non-significant relationship between social affordance and game part engagement.

The second one is what is the relationship between game part engagement and task part engagement, and their differences in influencing mechanisms. Data analysis shows that game part engagement (mean=3.65) is slightly higher than task part engagement (mean=3.39), suggesting that players are more willing to participate in the game part of the game, and game part engagement positively affects task part engagement, reflecting the relationship between the two parts. The significance between the variables reflects the influence mechanism between game part engagement and task part engagement on purchase intention is different. The former indirectly enhances purchase intention through the influence of game intention, while the latter can not only affect purchase intention through game intention, but also have a direct impact on purchase intention. The result that game part engagement did not have a direct effect on purchase intention was unexpected. The explanation for this result and the difference in the mechanism of the influence of game and task part engagement could be as follows. In promotional games such as shopping festival games, task part usually includes browsing products; the game part is similar to traditional games and is primarily related to fun, and its engagement is directly affected by game part affordance. Compared with the game part, the task part can have a more direct and significant impact on purchase intention because it strongly correlates with shopping. It provides an empirical foundation for the research on the specific gamification mechanism. The mechanism of the role of games is actually to help players transform from being interested in hedonic game part to task part with strong shopping relevance. The game part with high attraction to the users generates high user engagement, enhances the engagement in the task part with low engagement, and then influences the purchasing intention due to the strong shopping relevance of the task part.

### Theoretical Implications

First, this study enhances the richness of the gamification research model by considering the impact of gamification on psychological and behavioral outcomes. A review paper of empirical research on gamification mobile apps found that few empirical studies incorporated both psychological and behavioral outcomes into the same model for measurement (Sheffler et al., 2020). This study simultaneously incorporates engagement and purchase intention into the model. Further, most previous studies treat game as a whole (Garcia-Jurado et al., 2019; Rohan et al., 2021; Zhou et al., 2022). Our study classifies game into game part and task part based on the different attributes of gamification. We distinguished the engagement into game part engagement and task part engagement and discussed their relationship. Our results contribute to the theoretical understanding on the impact of gamification design.

Second, previous studies discuss the impact of game engagement as a whole (Garcia-Jurado et al., 2019; Ho et al., 2023; Suh et al., 2017), the role of different parts of the game in the purchase intention is unknown. Unlike previous studies, we explore the different impacts of two parts of the game on consumers' purchase intention. We respond to the call that gamification helps to accomplish the system's target task (Liu et al., 2017) and follow the view that the technology (e.g., gamification) applied to the system and the task should be congruent and relevant (Goodhue & Thompson, 1995). By doing so, we discovered the difference and connection between the two parts of the game in terms of their mechanisms, making a step forward in the research phase of gamification influence mechanisms. It is found that task part engagement in the gamification has a direct effect on the purchase

intention, while game part engagement plays an indirect role through task part engagement and does not play a direct role, which innovatively clarifies the mechanism of the gamification and provides novel insights into the interpretation of user behaviour in games.

### Practical Implications

By separating game and task part parts, our research reveals the influence mechanism of shopping festival games on purchase intention in e-commerce platforms, making the following contributions to the design and application of gamification in shopping platforms.

First of all, our findings provide empirical evidence for the effectiveness of shopping festival game part in promoting purchase intentions. According to our findings, what caught our attention was that in the game part of the shopping festival games, achievement and immersion affordances can greatly impact game part engagement, with immersion affordance having a higher degree of influence than achievement affordance, whereas social affordance does not have an active impact. Players are less willing to make friends in the shopping festival game, this result has to do with the attributes of users who adopt online shopping methods and want to avoid socialization. When designing shopping festival games, paying more attention to the design of multiple rewards and adding immersion elements in the game part is significant. Nevertheless, the social element is an important and unmissable part of the practical design. We remain convinced that social affordance can influence the final purchase from other paths of self-satisfaction than utilitarian and hedonic experiences.

Secondly, our findings help designers to understand which part of what design should be used to increase purchase intention. Based on the results of the data analysis, the game part does not directly affect the purchase intention but affects it through the task part. Therefore, for the shopping festival game on the e-commerce platform, it is necessary to pay attention to both the relationship between task part and game part and the relationship between task part and product purchase intention. Given the direct enhancement effect of task participation on purchase intention, the actual design of e-commerce shopping games should focus on the task part while not neglecting the game part that has an impact on engagement in the task part. For example, in the game part, we suggest setting up more interesting and task-relevant gameplay to increase the conversion rate of game engagement to task engagement. In the task part, we propose a personalized approach to recommending shops and products to the user, catering to consumer preferences to improve game participation and transaction conversion rates.

### Limitations and Future Research

There are several limitations. Firstly, this paper selected three dimensions of achievement, social and immersion to measure the game part affordance, but there are other dimensions such as competition, self-expression. Future research can consider exploring more dimensions of game affordances. Secondly, task part engagement may vary due to task voluntariness, task value. The purchase intention may also be affected by variables such as perceived relevance. Therefore, future research can introduce moderating variables and enrich research models. Finally, this study used a survey to measure the subjective thoughts of the respondents. In this process, there may be problems caused by the subjects' inertia in filling in, following the mainstream views, and self-cognition errors, which may have an impact on the authenticity of the data to a certain extent. In the future, research can be carried out by doing experiments or analyzing objective data.

### ACKNOWLEDGEMENT

We would like to thank the valuable comments and suggestions from track chair and reviews. The study was supported by grants from the National Natural Science Foundation of China (Project No. 71904149, 71974148), and the Major Projects of Ministry of Education Humanities and Social Sciences Key Research Base (Project No. 22JJD870002).

### REFERENCES

- Amo, L., Liao, R. C., Kishore, R., & Rao, H. R. (2020). Effects of structural and trait competitiveness stimulated by points and leaderboards on user engagement and performance growth: A natural experiment with gamification in an informal learning environment. *European Journal of Information Systems*, 29(6), 704-730. <https://doi.org/10.1080/0960085x.2020.1808540>
- Appelbaum, A. (2001). The constant customer. *Gallup Management Journal*, 1(2), 5.
- Ashley, C., & Tuten, T. (2015). Creative strategies in social media marketing: An exploratory study of branded social content and consumer engagement. *Psychology & Marketing*, 32(1), 15-27. <https://doi.org/10.1002/mar.20761>
- Bormann, D., & Greitemeyer, T. (2015). Immersed in virtual worlds and minds: effects of in-game storytelling on immersion, need satisfaction, and affective theory of mind. *Social Psychological and Personality Science*, 6(6), 646-652. <https://doi.org/10.1177/1948550615578177>
- Brodie, R. J., Hollebeek, L. D., Jurić, B., & Ilić, A. (2011). Customer Engagement. *Journal of Service Research*, 14(3), 252-271. <https://doi.org/10.1177/1094670511411703>
- Cantor, J. R., Bryant, J., & Zillmann, D. (1974). Enhancement of humor appreciation by transferred excitation. *Journal of Personality and Social Psychology*, 30(6), 812-821. <https://doi.org/10.1037/h0037543>
- Cheung, C. M. K., Lee, M. K. O., & Jin, X. (2011). Customer Engagement in an Online Social Platform: A Conceptual Model and Scale Development. *Proceedings of the International Conference on Information Systems, ICIS 2011, Shanghai, China, December 4-7, 2011*. DBLP.

- Cheung, C. M. K., Shen, X. L., Lee, Z. W. Y., & Chan, T. K. H. (2015). Promoting sales of online games through customer engagement. *Electronic Commerce Research and Applications*, 14(4), 241-250. <https://doi.org/10.1016/j.elerap.2015.03.001>
- Conaway, R., & Garay, M. C. (2014). Gamification and service marketing. *Springerplus*, 3(1), 1-11. <https://doi.org/10.1186/2193-1801-3-653>
- Deterding, S. (2014). Eudaimonic design, or: Six invitations to rethink gamification.
- Deterding, S., Dixon, D., Khaled, R., & Nacke, L. (2011, September). From game design elements to gamefulness: defining "gamification". In *Proceedings of the 15th international academic MindTrek conference: Envisioning future media environments* (pp. 9-15). <https://doi.org/10.1145/2181037.2181040>
- Dong, X. Y., & Wang, T. N. (2018). Social tie formation in Chinese online social commerce: The role of IT affordances. *International Journal of Information Management*, 42, 49-64. <https://doi.org/10.1016/j.ijinfomgt.2018.06.002>
- Feng, X., Li, Y., Lin, X., & Ning, Y. (2020). Mobile targeting in industrial marketing: Connecting with the right businesses. *Industrial Marketing Management*, 86, 65-76. <https://doi.org/10.1016/j.indmarman.2019.06.007>
- Francisco-Aparicio, A., Gutiérrez-Vela, F. L., Isla-Montes, J. L., & Sanchez, J. L. G. (2013). Gamification: analysis and application. *New trends in interaction, virtual reality and modeling*, 113-126. [https://doi.org/10.1007/978-1-4471-5445-7\\_9](https://doi.org/10.1007/978-1-4471-5445-7_9)
- Garcia-Jurado, A., Castro-Gonzalez, P., Torres-Jimenez, M., & Leal-Rodriguez, A. L. (2019). Evaluating the role of gamification and flow in e-consumers: millennials versus generation X. *Kybernetes*, 48(6), 1278-1300. <https://doi.org/10.1108/k-07-2018-0350>
- Gibson, J. J. (1978). The ecological approach to the visual perception of pictures. *Leonardo*, 11(3), 227-235. <https://doi.org/10.2307/1574154>
- Goodhue, D. L., & Thompson, R. L. (1995). Task-technology fit and individual performance. *MIS quarterly*, 213-236. <https://doi.org/10.2307/249689>
- Grewal, D., Krishnan, R., Baker, J., & Borin, N. (1998). The effect of store name, brand name and price discounts on consumers' evaluations and purchase intentions. *Journal of Retailing*, 74(3), 331-352. [https://doi.org/10.1016/s0022-4359\(99\)80099-2](https://doi.org/10.1016/s0022-4359(99)80099-2)
- Hair, J. F., Ringle, C. M., & Sarstedt, M. (2011). PLS-SEM: Indeed a silver bullet. *Journal of marketing theory and practice*, 19(2), 139-152. <https://doi.org/10.2753/MTP1069-6679190202>
- Hamari, J. (2017). Do badges increase user activity? A field experiment on the effects of gamification. *Computers in Human Behavior*, 71, 469-478. <https://doi.org/10.1016/j.chb.2015.03.036>
- Hamari, J., & Koivisto, J. (2014). Measuring flow in gamification: Dispositional Flow Scale-2. *Computers in Human Behavior*, 40, 133-143. <https://doi.org/10.1016/j.chb.2014.07.048>
- Hamari, J., Koivisto, J., & Sarsa, H. (2014, January). Does gamification work? --a literature review of empirical studies on gamification. In *2014 47th Hawaii international conference on system sciences* (pp. 3025-3034). Ieee.
- Hildebrand, C., Schlager, T., Herrmann, A., & Häubl, G. (2014). Product gamification. *Advances in Consumer Research*, 42, 664-665.
- Ho, Y. J., Liu, S., & Wang, L. (2023). Fun shopping: A randomized field experiment on gamification. *Information Systems Research*, 34(2), 766-785. <https://doi.org/10.2139/ssrn.3542045>
- Hofacker, C. F., de Ruyter, K., Lurie, N. H., Manchanda, P., & Donaldson, J. (2016). Gamification and Mobile Marketing Effectiveness. *Journal of Interactive Marketing*, 34, 25-36. <https://doi.org/10.1016/j.intmar.2016.03.001>
- Hollebeek, L. (2011). Exploring customer brand engagement: definition and themes. *Journal of Strategic Marketing*, 19(7), 555-573. <https://doi.org/10.1080/0965254x.2011.599493>
- Hollebeek, L. D., Glynn, M. S., & Brodie, R. J. (2014). Consumer Brand Engagement in Social Media: Conceptualization, Scale Development and Validation. *Journal of Interactive Marketing*, 28(2), 149-165. <https://doi.org/10.1016/j.intmar.2013.12.002>
- Holzer, A., Kocher, B., Bendahan, S., Vonèche Cardia, I., Mazuze, J., & Gillet, D. (2020). Gamifying knowledge sharing in humanitarian organisations: a design science journey. *European Journal of Information Systems*, 29(2), 153-171. <https://doi.org/10.1080/0960085X.2020.1718009>
- Hunicke, R., LeBlanc, M., & Zubeck, R. (2004, July). MDA: A formal approach to game design and game research. In *Proceedings of the AAAI Workshop on Challenges in Game AI* (Vol. 4, No. 1, p. 1722).
- Huotari, K., & Hamari, J. (2012, October). Defining gamification: a service marketing perspective. In *Proceeding of the 16th international academic MindTrek conference* (pp. 17-22).
- Kapko, M. (2014). How Gamification Drives Business Objectives. *CIO*. Retrieved from <https://www.cio.com/article/291097/collaboration-software-how-gamification-drives-business-objectives.html> (accessed 8 October 2023).
- Kim, K., Schmierbach, M. G., Bellur, S., Chung, M. Y., Fraustino, J. D., Dardis, F., & Ahern, L. (2015). Is it a sense of autonomy, control, or attachment? Exploring the effects of in-game customization on game enjoyment. *Computers in Human Behavior*, 48, 695-705. <https://doi.org/10.1016/j.chb.2015.02.011>
- Koivisto, J., & Hamari, J. (2019). The rise of motivational information systems: A review of gamification research. *International Journal of Information Management*, 45, 191-210. <https://doi.org/10.1016/j.ijinfomgt.2018.10.013>
- Lankton, N. K., McKnight, D. H., & Tripp, J. (2015). Technology, Humanness, and Trust: Rethinking Trust in Technology. *Journal of the Association for Information Systems*, 16(10), 880-918. <https://doi.org/10.17705/1jais.00411>

- Lee, Z. W. Y., Cheung, C. M. K., & Chan, T. K. H. (2021). Understanding massively multiplayer online role-playing game addiction: A hedonic management perspective. *Information Systems Journal*, 31(1), 33-61. <https://doi.org/10.1111/isj.12292>
- Liu, D., Santhanam, R., & Webster, J. (2017). Toward Meaningful Engagement: a framework for design and research of gamified information systems. *MIS quarterly*, 41(4), 1011-1034. <https://doi.org/10.25300/MISQ/2017/41.4.01>
- Markus, M. L., & Silver, M. S. (2008). A Foundation for the Study of IT Effects: A New Look at DeSanctis and Poole's Concepts of Structural Features and Spirit. *Journal of the Association for Information Systems*, 9(10), 609-632.
- Norman, D. A. (1988). The psychology of everyday things. *Basic Books*.
- Ozen, H., & Engizek, N. (2014). Shopping online without thinking: being emotional or rational?. *Asia pacific journal of marketing and logistics*, 26(1), 78-93. <https://doi.org/10.1108/apjml-06-2013-0066>
- Ping, Z. (2008). Motivational Affordances: Reasons for ICT Design and Use. *Communications of the Acm*, 51(11), 145-147. <https://doi.org/10.1145/1400214.1400244>
- Rohan, R., Pal, D., Funilkul, S., Chutimaskul, W., & Eamsinwattana, W. (2021). How Gamification Leads to Continued Usage of MOOCs? A Theoretical Perspective. *Ieee Access*, 9, 108144-108161. <https://doi.org/10.1109/access.2021.3102293>
- Sheffler, Z. J., Liu, D., & Curley, S. P. (2020). Ingredients for successful badges: evidence from a field experiment in bike commuting. *European Journal of Information Systems*, 29(6), 688-703. <https://doi.org/10.1080/0960085X.2020.1808539>
- Shi, S., Leung, W. K. S., & Munelli, F. (2022). Gamification in OTA platforms: A mixed-methods research involving online shopping carnival. *Tourism Management*, 88, Article 104426. <https://doi.org/10.1016/j.tourman.2021.104426>
- Sigala, M. (2015). The application and impact of gamification funware on trip planning and experiences: the case of TripAdvisor's funware. *Electronic Markets*, 25(3), 189-209. <https://doi.org/10.1007/s12525-014-0179-1>
- Suh, A., Cheung, C. M. K., Ahuja, M., & Wagner, C. (2017). Gamification in the workplace: The central role of the aesthetic experience. *Journal of Management Information Systems*, 34(1), 268-305. <https://doi.org/10.1080/07421222.2017.1297642>
- Taşkıran, N. Ö., & Yılmaz, R. (2015). *Handbook of research on effective advertising strategies in the social media age*. Business Science Reference.
- Vivek, S. D. (2009). *A scale of consumer engagement*. The University of Alabama.
- Wijman, T. (2023). New free report: Explore the global games market in 2023. *newzoo*. Retrieved from <https://newzoo.com/resources/blog/explore-the-global-games-market-in-2023> (accessed 8 October 2023).
- Xi, N., & Hamari, J. (2019). Does gamification satisfy needs? A study on the relationship between gamification features and intrinsic need satisfaction. *International Journal of Information Management*, 46, 210-221. <https://doi.org/10.1016/j.ijinfomgt.2018.12.002>
- Xu, Y., Chen, Z., Peng, M. Y. P., & Anser, M. K. (2020). Enhancing Consumer Online Purchase Intention Through Gamification in China: Perspective of Cognitive Evaluation Theory. *Frontiers in Psychology*, 11, Article 581200. <https://doi.org/10.3389/fpsyg.2020.581200>
- Yang, L., & Gottlieb, M. (2023). Gamification Mobile Applications: A Literature Review of Empirical Studies. In *International Conference on Interactive Collaborative Learning* (pp. 933-946). Springer, Cham.
- Yee, N. (2006). Motivations for play in online games. *Cyberpsychology & Behavior*, 9(6), 772-775. <https://doi.org/10.1089/cpb.2006.9.772>
- Yu, N., & Huang, Y. T. (2022). Why do people play games on mobile commerce platforms? An empirical study on the influence of gamification on purchase intention. *Computers in Human Behavior*, 126, Article 106991. <https://doi.org/10.1016/j.chb.2021.106991>
- Zagal, J. P., Mateas, M., Fernández-Vara, C., Hochhalter, B., & Lichti, N. (2005, June). Towards an ontological language for game analysis. In *DiGRA Conference*.
- Zhou, F., Mou, J. A., & Kim, J. (2022). Toward a meaningful experience: an explanation of the drivers of the continued usage of gamified mobile app services. *Online Information Review*, 46(2), 285-303. <https://doi.org/10.1108/oir-10-2020-0464>
- Zichermann, G., & Linder, J. (2010). *Game-based marketing: inspire customer loyalty through rewards, challenges, and contests*. John Wiley & Sons.

## Domain-Adversarial Neural Network with Joint-Distribution Adaption for Credit Risk Classification

Jian-Shan Pan<sup>1</sup>  
Yi-Qiong Wu<sup>2,\*</sup>  
Yang Lv<sup>3,\*</sup>  
Qi-You Lin<sup>4</sup>  
Jin-Rui Peng<sup>5</sup>  
Min Ye<sup>6,7,\*</sup>  
Xiao-Fang Cai<sup>8,\*</sup>  
Wayne Wei Huang<sup>9</sup>

\*Corresponding author

<sup>1</sup> Shenzhen Public Credit Center, Shenzhen, China, panjs@mail.amr.sz.gov.cn

<sup>2</sup> Xi'an Jiaotong University, Xi'an, China, yiqiongw10@163.com

<sup>3</sup> Shenzhen Public Credit Center, Shenzhen, China, yangl2023@mail.amr.sz.gov.cn

<sup>4</sup> Shenzhen Public Credit Center, Shenzhen, China, linqy1@mail.amr.sz.gov.cn

<sup>5</sup> Shenzhen Public Credit Center, Shenzhen, China, pengjr2023@mail.amr.sz.gov.cn

<sup>6</sup> Xi'an Jiaotong University, Xi'an, China, yew06@qq.com

<sup>7</sup> Lanshi Lantuo Agricultural Equipment Limited Company, Lanzhou, China

<sup>8</sup> National Center for Applied Mathematics-Shenzhen (NCAMS), Southern University of Science and Technology (SUSTech), Shenzhen, China, caixf@mail.sustech.edu.cn

<sup>9</sup> College of Business and NCAMS, SUSTech, Shenzhen, China, waynehw@qq.com

### ABSTRACT

Financial institutions normally have limited applicants and small sample credit datasets in early stages of business. Machine learning models may get overfitted due to a lack of sufficient training samples, which will lower the models' classification accuracy. This paper proposes a novel transfer learning model to tackle this challenge, via aligning the conditional probability distribution and the marginal probability distribution between traditional businesses and new businesses. We conduct experiments on two real credit datasets to validate the model. Experimental results show that the proposed model outperforms other benchmark algorithms in prediction accuracy. The proposed model could have the potential for various application scenarios, including the utilization of non-financial data such as legal documents for credit rating or related risk assessments.

*Keywords:* Credit risk, deep learning, transfer learning, distribution adaption.

### INTRODUCTION

An increasing number of traditional financial institutions have established automatic risk management mechanisms based on machine learning. A major problem that many financial institutions confront is that they only have a small number of training samples in their early stages. This problem makes it challenging to develop a reliable credit scoring model to help P2P platforms prevent potential financial loss brought by the default of applications. Therefore, properly addressing the small sample problem becomes a critical issue in credit scoring tasks.

While augmenting the training data for credit scoring models tailored to current nascent business by annotating additional data from ongoing operations is theoretically plausible; in practical terms, this approach is deemed impractical and time-consuming (Ghaffari *et al.*, 2023). When a mature credit business with substantial data volumes exists and is pertinent to the current nascent credit business operations, leveraging transfer learning techniques to transfer knowledge from the mature credit business to the nascent credit business is considered an effective means to enhance the performance of credit risk classification models (Li *et al.*, 2019).

Transfer learning is the process by which a system adapts to new circumstances, tasks, or surroundings by transferring knowledge from related tasks (Pang & Yang, 2010). Transfer learning has been successfully applied in various domains, such as natural language processing and computer vision (Zheng & Yang, 2022; Chen *et al.*, 2020). Existing research results have confirmed the effectiveness of the strategy of "introducing transfer learning techniques to transfer relevant mature credit business knowledge to address the small sample problem." However, the application of transfer learning in the context of credit scoring is still in its nascent stages.



The process of knowledge transfer from a mature credit business to a nascent credit business, simultaneously involving both conditional probability distribution divergence and marginal probability distribution divergence, represents a significant challenge. In the case of credit risk classification issues, the different credit access requirements in different loan businesses may lead to discrepancies among corresponding customer groups. Therefore, when conducting transfer learning in this study, it is important to consider that the source domain (mature credit business) and the target domain (nascent credit business) may have different marginal probability distributions. Meanwhile, there are differences between various credit businesses in terms of collateral, and interest rates. Even when given the same (accessible) customer characteristics, disparities in any of the aforementioned aspects may lead to variations in customer repayment capacity and willingness, subsequently resulting in differences in customer default behavior (Li *et al.*, 2023). In other words, for related credit businesses, even when sharing the same feature space, the relationship between customer characteristics and customer repayment behavior may exhibit disparities. Based on this, it is also necessary for this study to consider situations where the source domain and target domain have different conditional probability distributions when performing transfer learning. However, most existing studies largely ignore the differences in conditional probability distributions between the source and target domain data, only narrowing the gap in marginal probability distribution between domains (Iwai, Akiyoshi, & Hamagami, 2021). Adopting an algorithm strategy that only narrows the gap in marginal probability distribution between domains may lead to the “negative transfer” issue, resulting in inadequate predictive performance of the model in the target domain.

The significantly larger volume of mature credit business data compared to that of nascent credit business data presents another challenge in the process of transfer learning modeling. This business reality may lead to the model overemphasizing the tasks related to mature credit business, consequently resulting in poor generalization performance of the model in the nascent credit business (Zheng & Yang, 2022). Existing studies overlook the fact that the source domain data dominates in quantity.

To address these two challenges, this study proposed an improved transfer learning method based on the domain-adversarial neural network. The proposed method not only can align both the marginal probability distribution and conditional probability distribution between the source and target domain data simultaneously, but also can guide the model to pay more attention to the current nascent credit scoring task.

### MODEL CONSTRUCTION

In this study, the credit scoring problem is formulated as a binary classification task (Wu *et al.*, 2022). Input vectors and their corresponding labels are denoted as  $x \in \mathbb{R}^D$  and  $y \in \{0, 1\}$ , respectively, where  $D$  represents the dimension of input vectors. Here,  $y = 0$  represents defaulted loan applications, while  $y = 1$  represents non-defaulted loan applications. In this study, the training set consists of  $n^S$  labeled samples  $\mathbb{D}^S = \{(x_i^S, y_i^S)\}_{i=1}^{n^S}$  from the source domain (mature credit business), and  $n^T$  labeled samples  $\mathbb{D}^T = \{(x_i^T, y_i^T)\}_{i=1}^{n^T}$  from the target domain (new credit business), where  $n^T \ll n^S$ . Both the source and target domain samples share the same feature space  $\mathcal{X}^S = \mathcal{X}^T$  and the same label space  $\mathcal{Y}^S = \mathcal{Y}^T$ ; however, they have different marginal probability distributions  $P(x^S) \neq P(x^T)$ , as well as different conditional probability distributions  $P(y^S|x^S) \neq P(y^T|x^T)$ .

#### The Proposed Domain-Adversarial Neural Network with Joint-Distribution Adaption and Loss Rectification

In order to achieve effective knowledge transfer between business domains and address the aforementioned research challenges, this study proposes a novel transfer learning model named domain-adversarial neural network with joint-distribution adaption and loss rectification (DANN-JDA-LR). Figure 1 gives the framework of the proposed model. The proposed method consists of two major modules, a domain-adversarial neural network for achieving joint-distribution adaption and a loss rectification module. The details of the proposed model will be introduced in the following.

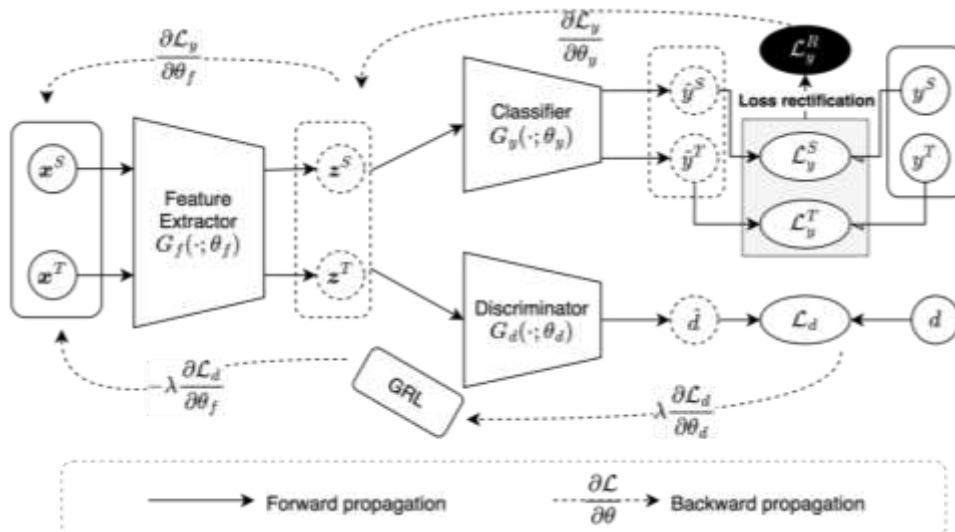

Figure 1: Domain-adversarial neural network with joint-distribution adaption and loss rectification.

### Domain-Adversarial Neural Network

Ganin *et al.* (2016) proposed the domain-adversarial neural network (DANN) for achieving alignment of marginal probability distributions between the source domain data and target domain data. Generally, the implementation of the domain-adversarial neural network can be divided into the following three steps. Firstly, aligning the distributions between the source and target domains. This is achieved by mapping source domain features and target domain features to the same space through a feature extractor, where the distributions between source domain features and target domain features are made as ‘close’ as possible. Secondly, training a classifier on the labeled source domain data with mapped feature representations. Thirdly, training a domain discriminator on the source domain data and the target domain data, whose labels are assigned based on whether they belong to the source domain.

In DANN, an effective feature representation should possess two key characteristics, discriminativeness and domain-invariance, simultaneously. The discriminativeness means that the classifier within the model can perform the credit scoring task effectively based on the mapped feature representation. The domain-invariance implies that the domain discriminator within the model cannot identify which domain the data came from based on the mapped feature representation. To meet the aforementioned requirements, during the DANN training process, the parameter optimization of the feature extractor is viewed as a process that simultaneously minimizes the credit risk classification loss and maximizes the domain discrimination loss. As shown in Figure 1, the traditional DANN structure consists of three components: a feature extractor  $G_f(\cdot, \theta_f)$ , a classifier  $G_y(\cdot, \theta_y)$ , and a domain discriminator  $G_d(\cdot, \theta_d)$ , where  $\theta_f$ ,  $\theta_y$ , and  $\theta_d$  represent the parameters of the respective networks.

The feature extractor  $G_f$  learns a function  $G_f(\cdot, \theta_f): \mathbf{x} \rightarrow \mathbb{R}^M$  through the training process, mapping the original  $D$ -dimensional feature representation to an  $M$ -dimensional feature representation (denoted as  $\mathbf{z}$  in Figure 1). The classifier  $G_y$ , through the training process, learns a function  $G_y(\cdot, \theta_y): \mathbf{z} \rightarrow \hat{y}$ , which maps the  $M$ -dimensional feature representation to a default probability  $\hat{y} \in [0, 1]$ . Similarly, the domain discriminator  $G_d$ , during the training process, learns a function  $G_d(\cdot, \theta_d): \mathbf{z} \rightarrow \hat{d}$ , which maps the  $M$ -dimensional feature representation to the probability of data belonging to the source domain, denoted as  $\hat{d} \in [0, 1]$ . In the DANN training process, Eq. (1) and Eq. (2) can be used to calculate the credit risk classification loss  $\mathcal{L}_y$  and the domain discrimination loss  $\mathcal{L}_d$ , respectively. These two prediction losses can be formulated based on the cross-entropy loss function.

$$\begin{aligned} \mathcal{L}_y(\theta_f, \theta_y) &= \mathcal{L}_y(G_y(G_f(\mathbf{x}; \theta_f); \theta_y), \mathbf{y}) \\ &= \frac{1}{N_y} \sum_{i=1}^{N_y} [-y_i \cdot \log(\hat{y}_i) + (1 - y_i) \cdot (1 - \log(\hat{y}_i))] \end{aligned} \quad (1)$$

$$\begin{aligned} \mathcal{L}_d(\theta_f, \theta_d) &= \mathcal{L}_d(G_d(G_f(\mathbf{x}; \theta_f); \theta_d), \mathbf{d}) \\ &= \frac{1}{N_d} \sum_{i=1}^{N_d} [-d_i \cdot \log(\hat{d}_i) + (1 - d_i) \cdot (1 - \log(\hat{d}_i))] \end{aligned} \quad (2)$$

Where  $N_y$  and  $N_d$  represent the numbers of training samples for the classifier and the domain discriminator, respectively. It's worth noting that in the original DANN,  $N_y = n^s$ , and  $N_d = n^s + n^T$ . However, this approach makes it difficult to align the conditional probability distributions between domains. In this study, the domain discrimination loss  $\mathcal{L}_d$  is still computed using Eq. (2), while the credit risk classification loss  $\mathcal{L}_y$  is computed using the proposed rectification loss  $\mathcal{L}_y^R$ . The details of the loss rectification strategy introduced in this study will be given in the following section.

Furthermore, during the training process, the optimization of DANN's parameters ( $\theta_f$ ,  $\theta_y$ , and  $\theta_d$ ) involves minimizing the function  $E(\theta_f, \theta_y, \theta_d)$ . The formula for calculating  $E(\theta_f, \theta_y, \theta_d)$  is as follows.

$$E(\theta_f, \theta_y, \theta_d) = \mathcal{L}_y(\theta_f, \theta_y) + \lambda \mathcal{L}_d(\theta_f, \theta_d) \quad (3)$$

Where  $\lambda$  is used to balance the losses between classification prediction and domain prediction. As shown in Eq. (4) and Eq. (5), DANN obtains the optimal values of  $\theta_f$  and  $\theta_y$  by minimizing  $E(\theta_f, \theta_y, \theta_d)$  and obtains the optimal value of  $\theta_d$  by maximizing  $E(\theta_f, \theta_y, \theta_d)$ .

$$(\hat{\theta}_f, \hat{\theta}_y) = \arg \min_{\theta_f, \theta_y} E(\theta_f, \theta_y, \hat{\theta}_d) \quad (4)$$

$$\hat{\theta}_d = \arg \max_{\theta_d} E(\hat{\theta}_f, \hat{\theta}_y, \theta_d) \quad (5)$$

To solve for  $\hat{\theta}_f$ ,  $\hat{\theta}_y$ , and  $\hat{\theta}_d$ , DANN introduces a gradient reversal layer (GRL). As shown in Figure 1, the GRL layer is inserted between the feature extractor  $G_f$  and the domain discriminator  $G_d$ . During the forward propagation process in the neural network training, the GRL layer performs an identity transformation. However, during the backward propagation process, the GRL layer



automatically reverses gradients, meaning that when the gradient of the domain classification loss from the domain discriminator propagates back to the feature extractor, it is automatically reversed. Viewing the GRL layer as a “pseudo-function”  $\mathcal{R}(\cdot)$ , the forward and backward propagation processes of GRL can be represented by Eq. (6) and Eq. (7) respectively.

$$\mathcal{R}(x) = x \quad (6)$$

$$\frac{d\mathcal{R}}{dx} = -\lambda I \quad (7)$$

Where  $I$  represents the identity matrix.

### The Loss Rectification Module

When applying the original DANN model to the research context in this study, two key issues need to be considered. Firstly, within the scope of this study’s research context, there exist both conditional probability distribution and marginal probability distribution divergences between the source domain data and the target domain data. In the original DANN model, only the source domain data is employed for training the classifier. Therefore, the original DANN model implicitly assumes that there is only marginal probability distribution divergence between the source domain data and the target domain data. Secondly, within the research context of this study, labeled source domain data and labeled target domain data can be simultaneously used for training the classifier. However, the quantity of labeled target domain data is significantly smaller than that of labeled source domain data. This can easily lead to the classifier exhibiting ‘strong supervision’ on the source domain data, which in turn impacts the generalization performance of the classifier on the target domain data.

Considering the aforementioned issues, this study first conducts research by simultaneously employing source domain data and target domain data to train the classifier. This involves minimizing the classifier’s credit risk classification loss on both the source and target domain data to optimize classifier parameters, thereby aligning the conditional distributions between the source and target domains (Sun *et al.*, 2022). Secondly, this study introduces a loss rectification strategy to prevent the classifier from overly focusing on labeled source domain data, which could otherwise result in suboptimal classification accuracy on the target domain. Eq. (8) is employed in this study as the loss function for the classifier within the proposed model to achieve loss rectification objectives.

$$\mathcal{L}_y^R = \mathcal{L}_y^S * \exp(-\mathcal{L}_y^T) + \mathcal{L}_y^T \quad (8)$$

Where  $\mathcal{L}_y^S$  and  $\mathcal{L}_y^T$  are the cross-entropy losses of the classifier for the target domain and source domain, respectively. In Eq. (8), the first term,  $\mathcal{L}_y^S * \exp(-\mathcal{L}_y^T)$ , primarily serves the purpose of penalizing the prediction loss in the source domain. Simultaneously, this term introduces the exponential factor  $\exp(-\mathcal{L}_y^T)$  to ensure that when the prediction loss  $\mathcal{L}_y^T$  in the target domain becomes significantly larger, the model prioritizes penalizing the target domain prediction loss  $\mathcal{L}_y^T$  over penalizing the source domain prediction loss  $\mathcal{L}_y^S$ . The second term in Eq. (8),  $\mathcal{L}_y^T$ , is mainly utilized to penalize the prediction loss  $\mathcal{L}_y^T$  in the target domain. While the loss rectification strategy proposed in this study cannot guarantee the optimality (minimization) of the source domain’s credit risk classification losses under all conditions, it can ensure that the classifier exhibits superior credit risk classification performance for target domain data, aligning with the original design intent of this study’s research model.

## EXPERIMENTAL DESIGN

### Dataset Description

In this study, we validate the effectiveness of the proposed model using a real credit dataset provided by Qianhai Zheng Xin. The Qianhai credit dataset comprises two sets of credit operations: a credit loan business (referred to as Business A) and a cash loan business (referred to as Business B). These two sets of credit businesses are related but different. Each credit record in the original datasets corresponds to the same 490 attributes, with the “flag” variable serving as the dependent variable in this study. This study constructs two sets of datasets based on the Qianhai credit dataset, considering two knowledge transfer scenarios: ‘knowledge transfer from business A to business B (A→B)’ and ‘knowledge transfer from business B to business A (B→A)’. Table 1 gives the dataset descriptions of these two transfer scenarios.

Table 1: Dataset descriptions of two transfer scenarios.

Transfer scenario	Source domain training set	Target domain training set	Target domain validation set	Target domain test set
A→B	3560	249	107	1159
B→A	1515	105	46	24913

### Model Implementation

This study utilizes the PyTorch deep learning library (Paszke *et al.*, 2019) to implement the proposed model, as well as other deep neural network benchmark models. The network architecture for the feature extractor is “D - 128 - 64 - 32”; the classifier’s network structure is “32 - 16 - 16 - 1”; and the domain discriminator’s network structure is “32 - 16 - 16 - 16 - 1”.

When training the neural network model, the maximum number of training epochs was set to 30. To prevent overfitting of the model, this study investigates the use of an early stopping strategy during model training. Specifically, during the model training process, if the training epoch exceeds 10 and the model's performance on the validation set does not improve for five consecutive training epochs, the training process will be terminated; otherwise, the model is trained for a total of 30 epochs. The initial learning rate was set to 0.1, and the learning rate was dynamically adjusted during training based on the validation set loss metric.

### Benchmark Models

In this study, to validate the effectiveness of the model proposed, ten sets of benchmark models were constructed and subjected to performance comparison and analysis. The utilized benchmark models can be categorized as Target-Only-Based Models (TO-Models), which are trained solely on the target domain dataset, Source and target-based Models (S&T-Models), which are trained on the dataset that directly mixes source domain and target domain data together, and transfer learning models. Given the imbalanced nature of credit data, before training the following benchmark models, a resampling technique, SMOTE, was applied to oversample both the source domain training set and the target domain training set (Zhang *et al.*, 2022). Table 2 lists the benchmark models utilized in this study.

Table 2: Benchmark models.

	Benchmark model
TO-Models	Random forest-TO (RF-TO) AdaBoost-TO Deep neural network-TO (DNN-TO)
S&T-Models	Random forest-S&T (RF-S&T) AdaBoost-S&T Deep neural network-S&T (DNN-S&T) Deep neural network-S&T with loss rectification (DNN-S&T w/ LR)
Transfer Learning Models	TrAdaBoost DANN Domain-adversarial neural network with joint-distribution adaption (DANN-JDA)

### Model Evaluation

This study conducts credit risk performance evaluation in two transfer scenarios. For credit risk classification tasks, selecting appropriate performance metrics is of paramount importance to ensure a comprehensive assessment of model effectiveness and guide classifier learning (Lessmann *et al.*, 2015). Some credit risk classification-related studies employ metrics such as accuracy, false positive rate, and false negative rate to evaluate predictive model performance (Moscatto, Picariello, & Sperli, 2021). In practical applications, the overall discriminative ability of credit risk classification models is often a critical concern. The Area Under the Receiver Operating Characteristic (ROC) Curve (AUC), the Kolmogorov-Smirnov (KS), and the G-mean are three widely used evaluation metrics for measuring the comprehensive discriminative ability of models (Guo *et al.*, 2022). The AUC value can reflect the overall discriminative capability of a model, the KS value can reflect the discriminative capability of the model at the optimal threshold, and the G-mean can simultaneously consider the model's precision and recall when dealing with imbalanced datasets (Yu, Zhang, & Yin, 2022). Therefore, this study used these three indicators to evaluate the predictive performance of a credit risk classification model. The larger the values of AUC, KS, and G-mean, the better the performance of the corresponding credit scoring model.

## RESULTS AND DISCUSSION

Based on the proposed credit scoring model and the benchmark models, this study conducts discussions and analyses in the following two aspects. First, a comprehensive performance comparison between the proposed credit scoring model and ten benchmark models is provided. Second, through conducting ablation experiments, this study further tests the effectiveness of the components within the proposed model.

In order to minimize the impact of training set variability and algorithm randomness, this study repeated each model experiment ten times. Table 3 presents the performance evaluation results of different credit risk classification models in the A → B and B → A scenarios, with the best results highlighted in bold. The AUC, KS, and G-mean values provided in the table are the averages of the results from ten experiments, with standard deviations shown in parentheses.

Table 3: Evaluation results for credit scoring models.

Transfer scenario	Model	AUC	KS	G-mean
A → B	RF-TO	0.5039 (0.0346)	0.0949 (0.0318)	0.0701 (0.0363)
	AdaBoost-TO	0.5341 (0.0242)	0.1278 (0.0394)	0.0733 (0.0342)
	DNN-TO	0.5199 (0.0381)	0.1118 (0.0290)	0.0518 (0.0321)
	RF-S&T	0.5218 (0.0363)	0.1025(0.0264)	0.0728 (0.0244)
	AdaBoost-S&T	0.5441 (0.0215)	0.1301 (0.0325)	0.0615 (0.0089)
	DNN-S&T	0.5410 (0.0311)	0.1230 (0.0343)	0.0795 (0.0306)
	DNN-S&T w/ LR	0.5471 (0.0288)	0.1303 (0.0336)	0.0802 (0.0227)

	TrAdaBoost	0.5113 (0.0272)	0.0485 (0.0333)	<b>0.0956</b> (0.0395)
	DANN	0.5404 (0.0261)	0.1208 (0.0400)	0.0668 (0.0209)
	DANN-JDA	0.5437 (0.0191)	0.1273 (0.0274)	0.0790 (0.0337)
	DANN-JDA-LR	<b>0.5490</b> (0.0347)	<b>0.1376</b> (0.0553)	0.0873 (0.0223)
B→A	RF-TO	0.5533 (0.0434)	0.0911 (0.0519)	0.1606 (0.0412)
	AdaBoost-TO	0.5328 (0.0386)	0.0707 (0.0389)	0.1540 (0.0378)
	DNN-TO	0.5311 (0.0343)	0.0688 (0.0413)	0.1497 (0.0327)
	RF-S&T	0.5475 (0.0165)	0.0754 (0.0218)	0.1575 (0.0234)
	AdaBoost-S&T	0.5410 (0.0168)	0.0748 (0.0195)	0.1573 (0.0151)
	DNN-S&T	0.5278 (0.0195)	0.0532 (0.0290)	0.1511 (0.0348)
	DNN-S&T w/ LR	0.5398 (0.0281)	0.0679 (0.0399)	0.1683 (0.0300)
	TrAdaBoost	0.5123 (0.0068)	0.0253 (0.0122)	0.1788 (0.0618)
	DANN	0.5228 (0.0226)	0.0550 (0.0237)	0.1453 (0.0242)
	DANN-JDA	0.5339 (0.0160)	0.0616 (0.0225)	0.1575 (0.0280)
	DANN-JDA-LR	<b>0.5573</b> (0.0191)	<b>0.0989</b> (0.0277)	<b>0.1880</b> (0.0183)

### Analysis of classification performance

Through Table 3, it can be observed that the proposed DANN-JDA-LR model achieved the best AUC and KS values in both transfer scenarios. In the  $B \rightarrow A$  scenario, it achieves the best G-mean value, and in the  $A \rightarrow B$  scenario, it achieves a G-mean value slightly lower than TrAdaBoost. Overall, compared to the baseline models, the proposed DANN-JDA-LR has superior credit scoring performance. The following will provide more detailed discussions regarding the models trained solely on the target domain data (TO-Models), models trained by directly-mixed dataset (S&T-Models), and the transfer learning models.

#### (1) TO-Models vs. S&T-Models

In the  $A \rightarrow B$  transfer scenario, although the G-mean value of the AdaBoost-S&T model is slightly worse than that of the AdaBoost-TO model, overall, the S&T-Models show improved performance compared to their corresponding TO-Models. However, in the  $B \rightarrow A$  transfer scenario, only the AdaBoost-S&T model exhibits improved performance compared to its corresponding AdaBoost-TO model. Both the RF-S&T model and DNN-S&T model perform worse in credit risk classification than their respective RF-TO models and DNN-TO models.

We infer that the main reasons for these results are twofold. Firstly, the original business A data represents mature credit operations, while business B represents newly initiated credit operations. Secondly, although there are shared features or patterns between business A and business B, there exist differences in the data distribution between them. More specifically, in the  $A \rightarrow B$  transfer scenario, the reason for the performance improvement of S&T-Models compared to TO-Models is that there are shared features or patterns between business A and business B, and the source domain data (the original business A data) is more diverse. This allows the model to gain beneficial information for the target domain task from the source domain data. In the  $B \rightarrow A$  transfer scenario, the reason why S&T-Models exhibit inferior performance compared to TO-Models is that, relatively speaking, the business A data used in the experiments contains richer information, while the business B data used in the experiments lacks diversity in its information. When the S&T-Models overfit the source domain data (i.e., the information-scarce business B data), it results in insufficient generalization ability in the target domain task, leading to inferior model performance compared to TO-Models.

In summary, it is possible to enhance model performance in the target domain by extracting shared knowledge from different but related domains. However, the two credit businesses have different marginal probability distributions and conditional probability distributions. Neglecting the data distribution divergences between domains may lead to an unstable and unreliable model. Therefore, in the context of this study, directly mixing source domain data with target domain data for credit risk model training is not an effective or suitable model-constructing approach.

#### (2) Transfer learning models

From Table 3, it can be observed that, overall, the credit risk classification performance of the TrAdaBoost transfer learning method is not only worse than other transfer learning methods but also worse than other non-transfer learning methods. The TrAdaBoost model is ineffective in the transfer scenarios discussed in this study. We infer that the reasons for this result can be attributed to two aspects. First, there are significant differences in both marginal probability distributions and conditional probability distributions between Business A and Business B, which makes it challenging for the TrAdaBoost model to handle domain distribution differences through simple weighting and sample selection methods. Second, the TrAdaBoost model only incorporates classifiers formed in the later stages of the iterative process. This strategy may lead to the neglect of globally optimal classifiers, thereby affecting the model's performance in the target domain task.

In two different transfer scenarios, except for the G-mean value in the  $A \rightarrow B$  transfer scenario, the performance evaluation indicators of the DANN-JDA model are superior to their corresponding DNN-TO and DNN-S&T models. The performance evaluation indicators of the DANN-JDA-LR model are better than their corresponding DNN-S&T w/ LR model in both transfer

scenarios. We infer that the reasons for this result can be attributed to the efficiency of aligning the marginal probability distribution and conditional probability distribution of both source domain data and target domain data simultaneously, which improves the effectiveness of domain-shared knowledge extraction and thus improves the performance of the target domain classification task.

### Analysis of ablation studies

The proposed DANN-JDA-LR consists of two main modules: the Domain Adversarial Neural Network module for achieving joint-distribution adaptation and the loss rectification module. Understanding the impact of each module is of significant importance. The necessity of introducing these two modules will be discussed in the following.

#### (1) The necessity of joint-distribution adaption

The original DANN model only aligns the marginal probability distributions between the source and target domains, while the DANN-JDA model aligns both the marginal probability distributions and the conditional probability distributions between the source and target domains. Comparing the performance evaluation results of the DANN-JDA and the original DANN in Table 3, it can be observed that, in both transfer scenarios, the DANN-JDA model exhibits a certain degree of performance improvement compared to the DANN model. We reasonably infer that simultaneously aligning the marginal probability distributions and the conditional probability distributions allows the model to gain beneficial information from the source domain data for the target domain task, achieving effective knowledge transfer and ultimately enhancing the model's credit risk classification performance.

#### (2) The necessity of loss rectification

This study examines the necessity of introducing the loss rectification module based on both the DNN-S&T-based models and the DANN-JDA-based models. When comparing DNN-S&T w/ LR to DNN-S&T, it can be observed that the introduction of the loss rectification strategy results in performance improvement in the target domain. Similar conclusions can be drawn when comparing the DANN-JDA-LR model to the DANN-JDA model. We reasonably speculate that the proposed loss rectification strategy can, to a certain extent, guide the model to focus more on the credit risk classification task of the target domain.

## CONCLUSION AND FUTURE WORKS

During the initial stages of the credit business, there are insufficient samples for model training. To address this problem, this study provides a credit scoring model suitable for the early stages of credit businesses, enabling the effective transfer of mature credit business knowledge to nascent credit businesses. The proposed model maps the original feature spaces of the source domain and the target domain into a shared feature space that is both discriminative and domain-invariant, which can align the domains' conditional probability distributions and marginal probability distributions simultaneously. Additionally, a loss rectification strategy is introduced to mitigate the problem of "overfitting to the source domain task".

This study is of paramount importance for financial institutions engaged in credit risk management during the early stages of credit business. The proposed model can assist financial institutions in more accurately identifying potential defaulting and non-defaulting customers, thereby reducing losses stemming from erroneous lending decisions and enhancing the risk management capabilities of financial institutions. In the future, we will continue to investigate the usage of the proposed model and apply it to other fields, such as market risk regulation, to obtain the model with good generalizability.

## ACKNOWLEDGMENT

The 2<sup>nd</sup> and 8<sup>th</sup> authors would like to acknowledge the partial grant support to the research (Grant ID: 72061127002) and the 7<sup>th</sup> author to the Young Innovative Talent Program of Guangdong (Grant ID: 2023WQNCX067). This research is also supported by DeFin research center, National Center for Applied Mathematics Shenzhen, Shenzhen Key Research Base in Arts & Social Sciences (Intelligent Management & Innovation Research Center, SUSTech, Shenzhen), and the National Laboratory of Mechanical Manufacture System, XJTU, China.

## REFERENCES

- Chen, Y., Yang, C., Zhang, Y., & Li, Y. (2020). Deep conditional adaptation networks and label correlation transfer for unsupervised domain adaption, *Pattern Recognition*, 98, 107072. <https://doi.org/10.1016/j.patcog.2019.107072>
- Ganin, Y., Ustinova, E., Ajakan, H., Germain, P., Larochelle, H., Laviolette, F., Marchand, M., & Lempitsky, V. (2016). Domain-adversarial training of neural networks. *The Journal of Machine Learning Research*, 17(1), 2096-2030. [https://doi.org/10.1007/978-3-319-58347-1\\_10](https://doi.org/10.1007/978-3-319-58347-1_10)
- Ghaffari, R., Helfroush, M.S., Khosravi, A., Kazemi, K., Danyali, H., & Rutkowski, L. (2023). Toward domain adaptation with open-set target data: Review of theory and computer vision applications. *Information Fusion*, 100, 101912. <https://doi.org/10.1016/j.inffus.2023.101912>
- Guo, W., & Zhou, Z.Z. (2022). A comparative study of combining tree-based feature selection methods and classifiers in personal loan default prediction. *Journal of Forecasting*, 41(6), 1248-1313. <https://doi.org/10.1002/for.2856>
- Iwai, K., Akiyoshi, M., & Hamagami, T. (2021). Bayesian network-oriented transfer learning method for credit scoring model. *IEEJ Transactions on Electrical and Electronic Engineering*, 16(9), 1195-1202. <https://doi.org/10.1002/tee.23417>

- Lessmann, S., Baensens, B., Seow, H., & Thomas, L.C. (2015). Benchmarking state-of-the-art classification algorithms for credit scoring: An update of research. *European Journal of Operational Research*, 247(1), 124-136. <https://doi.org/10.1016/j.ejor.2015.05.030>
- Li, Q., Yu, Y., Li, Y., & Sun, G. (2023). Heterogeneous social network shape ability and willingness of rural residents to repay loans in China. *Research in International Business and Finance*, 65, 101971. <https://doi.org/10.1016/j.ribaf.2023.101971>
- Li, W., Ding, S., Chen, Y., Wang, H., & Yang, S. (2019). Transfer learning-based default prediction model for consumer credit in China. *The Journal of Supercomputing*, 75, 862-884. <https://doi.org/10.1007/s11227-018-2619-8>
- Moscato, V., Picariello, A., & Sperli, G. (2021). A benchmark of machine learning approaches for credit score prediction. *Expert Systems with Applications*, 165, 113986. <https://doi.org/10.1016/j.eswa.2020.113986>
- Pan, S.J., & Yang, Q. (2010). A survey on transfer learning. *IEEE Transactions on Knowledge and Data Engineering*, 22(10), 1345-1359. <https://doi.org/10.1109/TKDE.2009.191>
- Paszke A., Gross S., Massa F., Lerer, A., Bradbury, J., Chanan, G., Killeen, T., Lin, Z., Gimelshein, N., Antiga, L., Desmaison, A., Köpf, A., Yang, E., DeVito, Z., Raison, M., Tejani, A., Chilamkurthy, S., Steiner, B., Fang, L., Bai, J., & Chintala, S. (2019). PyTorch: An Imperative Style, High-Performance Deep Learning Library. In *Proceedings of the 33rd International Conference on Neural Information Processing Systems* (pp. 8026–8037). NIPS'19, Red Hook, NY, USA, December. <https://dl.acm.org/doi/10.5555/3454287.3455008>
- Sun, Y., Lu, T., Wang, C., Li, Y., Fu, H., Dong, J., & Xu, Y. (2022). TransBoost: A Boosting-Tree Kernel Transfer Learning Algorithm for Improving Financial Inclusion. *Proceedings of the AAAI Conference on Artificial Intelligence*, 36(11), 12181-12190. <https://doi.org/10.1609/aaai.v36i11.21478>
- Yu, L., Zhang, X., & Yin, H. (2022). An extreme learning machine based virtual sample generation method with feature engineering for credit risk assessment with data scarcity. *Expert Systems with Applications*, 202, 117363. <https://doi.org/10.1016/j.eswa.2022.117363>
- Wu, Y., Huang, W., Tian, Y., Zhu, Q., & Yu, L. (2022). An uncertainty-oriented cost-sensitive credit scoring framework with multi-objective feature selection. *Electronic Commerce Research and Applications*, 53, 101155. <https://doi.org/10.1016/j.eelerap.2022.101155>
- Zhang, A., Yu, H., Zhou, S., Huan Z., & Yang, X. (2022). Instance weighted SMOTE by indirectly exploring the data distribution. *Knowledge-Based Systems*, 249, 108919. <https://doi.org/10.1016/j.knosys.2022.108919>
- Zheng Z., & Yang, Y. (2022). Adaptive boosting for domain adaptation: Toward robust predictions in scene segmentation. *IEEE Transactions on Image Processing*, 31, 5371-5382. <https://doi.org/10.1109/TIP.2022.3195642>

## **Employee Demographics in Human Resource Space in Religious Not-For-Profit Organization in Australia: Understanding Organizational Retention Rates**

Suzie Pont <sup>1,\*</sup>  
John R. Hamilton <sup>2</sup>  
Stephen J. Maxwell <sup>3</sup>

\*Corresponding author

<sup>1</sup> Researcher, James Cook University, Cairns, Australia, PhD Student, Suzie.Pont@jcu.edu.au

<sup>2</sup> Adj. Chair Professor, James Cook University, Cairns, Australia, John.Hamilton@jcu.edu.au

<sup>3</sup> Researcher, Doctor, James Cook University, Cairns, Australia, Stephen.Maxwell@my.jcu.edu.au

### **ABSTRACT**

This study demonstrates that despite promotional discrimination favoring females in a female-dominated workplace, such females likely have reduced tenure compared to men. This delivers a significant difference in gender balance within upper management. An Australian not-for-profit organization's Qualtrics survey provides 113 respondent demographic data sets, or 56% of the potential respondent pool. Females are typically promoted significantly faster than males. However, while males are promoted slower than females, they remain longer in their tenured positions and ultimately move into upper management. Why women choose to leave an organization at higher rates, notwithstanding their promotional advantages, may indicate family child-raising interruptions, in-house personality clashes, or possibly deeper gendered biases within the organization - such as a lack of fulfilment and a greater predisposition to suffer negative workplace conditions. Hence, further research in this area is advised.

*Keywords:* Gender Bias, Management, Promotion, Tenure, Workplace reform.

### **INTRODUCTION**

Retention of staff in a dynamic environment, where demand for skilled labor outstrips labor market capacity, is one of the major concerns of an organization (Mabaso et al., 2021). In industries like human resources, with a predominantly female workforce, four key aspects of a workplace - the work environment, remuneration and job security, personal fulfilment, organizational values towards work-life balance, and fair treatment, help facilitate female retention (Hammond & Coetzee, 2022).

In human resources, there remains a growing demand for staff. Across such in-demand professions, the choice of workplace brings worker focus onto personal fulfilment and work-life balance considerations (Recuero & Segovia, 2021).

Fulfilment may be problematic for females to achieve - particularly in female-dominated workplaces (Jung & Welch, 2022). Male and female gender differences influence how each group socially connects in their workplace, with males (compared to females) showing greater connectedness in their work-life relative to their family life (Hodson, 2004).

This difference in connectedness has implications for workplace belonging. For example, when females dominate an internal workspace network, those working within it often feel less included and have reduced workplace satisfaction (Jung & Welch, 2022). In contrast, females and males have a greater sense of belonging when there are more males present. This, too, can influence the rates of retention within an organization, such that there is also a long-term bias in upper management towards males (Jung & Welch, 2022). Arguably, the lack of females in upper management is an area where cultural shifts towards improving personal fulfilment may bring some lessening of negative workplace conditions like stress and/or burnout and also assist in the reduction of gendered workplace disparities such as gender per capita pay (Rotenstein et al., 2021).

Understanding the role of family work-life balance can further explain the failure to retain females within the workforce (Burns et al., 2021; Recuero & Segovia, 2021). The natural increased use of emotional coping mechanisms in females, as opposed to the behavior coping using depersonalization, which is more typical in males, increases the risk of females suffering negative workplace emotional behaviors (Gonzalez-Morales et al., 2010; Recuero & Segovia, 2021).

Males and females have different ways of interpreting and responding to social demands. This can explain some disparity in their workplace behaviors - such as the propensity to suffer a negative workplace condition or to fail to mediate their work-life balance (Arman, 2020). This difference in coping strategies can lead to greater long-term retention of males in workplaces that often have higher rates of emotional exhaustion. This, in turn, can often induce higher coping strategies in females, leading to female work-life disruptions (Arman, 2020).

### Study Aim

Few recent studies have examined the demographics of a specific human resources department. The human resources profession remains a female-dominant workplace sector. However, within the organization, there remains a historical systemic discriminatory treatment perception of an inherent 'glass ceiling' that often limits a female's capacity to advance into senior management positions (Edgar & Geare, 2004). This study seeks to explore the current demographic composition of an Australian not-for-profit organization with a social service focus, to investigate the organization's diversity and equality in terms of demographic ratios, service history, and opportunity for advancement, and to relate this information to explain retention rates, and to assess the extent of male domination of upper management within the organization's human resource department.

## METHODOLOGY

### Target Organization

Anglicare Australia is an umbrella organization comprising a network of independent local, state, national and international organizations providing social services in their communities. Anglicare operates as a semi-autonomous branch of the Anglican Church with shared values through service delivery through a workforce comprising over 30,000 staff, including volunteers. Anglicare delivers more than 50 services, including housing, child protection, community services, youth services, aged care and support for people at risk of homelessness in Australian communities to more than 550,000 people, reaching nearly 1.3 million Australians.

Anglicare operates nationwide in the social welfare, aged care, and disability domains. The organization is diverse and multifaceted, with semi-autonomous divisions across Victoria, Tasmania, New South Wales, South Australia, Western Australia, Southeast Queensland, Central Queensland, North Queensland, and Anglicare Northern Territory. Given the diversity within the organization and the dispersed nature of the organization's operations across multiple locations, the targeted geographical population were asked to complete an online survey.

### Survey Activation

Anglicare Australia's executive Director assisted with this study by providing employee linkage to the Questionnaire, a cover letter explaining the survey's objectives, assurance of confidentiality, and lastly, explaining the voluntary nature of survey respondent participation.

### Data Capture

This study's mixed-methods data capture was presented as a Qualtrics survey to potential respondents over a 12-week period from 16 May to 31 July 2022. It followed a Dillman (2015) non-incentivized, six-differentiated fortnightly reminder approach. Anglicare Australia is a religious, not-for-profit organization. Its ethical requirement conditions allowed gender to be captured as one of three categories - male, female or other.

### Sample Size

Online survey respondents totalled 131 of an estimated overall pool of 200 surveys sent. However, after removing incomplete, section-blank, or demographic-incomplete surveys, plus removing two surveys with poor item delineation (either all neutral or all extreme responses), only 57% of the overall pool sufficiently completed the questionnaire items - leaving 113 suitably complete and usable cases available for this study's analysis.

### Data Collation

The demographic question provides an overview of the organization's workforce across gender, age, highest level of education, staff roles, and service duration. Respondent geographical respondents (mapped by IP address) also roughly match the Anglicare State-by-State HR workforce membership. Hence, data collection indicates a valid and suitable respondent representation of the Anglicare Australia organization.

## DATA ANALYSIS

Statistical analyses applied SPSS Version 28.0 (Statistical Package for the Social Sciences). An independent samples Chi-squared test determined if Anglicare's demographics differed from the Australian HR data obtained from the 2021 census, adjusted in February 2023 ( $H_0$  = no difference in the measures). One-way ANOVA determined differences in the number of years worked by gender. Promotion rates are calculated based on time of employment and time in the current position; there is an assumption that no employees were demoted. The demographics of the Anglicare HR workforce reflected 113 respondents answering the demographic questions, although not all respondents answered every question, which varied the respondent number (n) for some analysis.

## RESULTS

The areas the HR respondents worked in the organization covered areas from payroll to employee learning and development. Within the HR department, workplace roles were divided into six major areas of operations, with one category for undefined roles. The three minor cohorts with the HR Department (Learning and Development, Recruitment, Work Health and Safety) represent minor sections within Anglicare's HR departments. The level of non-specified roles indicates the diversity of the HR work environment. Respondents often have to deal with multifaceted problems that affect multiple organizational divisions,



making the compartmentalization of roles problematic. Furthermore, it is this diversity in workplace tasks that can affect the individuals' ability to form routines and how they define their roles within the organization, all of which can lead to negative workplace conditions as administrative controls are often unstructured as HR employees are expected to operate independently (Ma & Macmillan, 1999). Notably, the learning and development team, whose function is to prepare and empower employees to deal with the vicissitudes of work, is critical to managing negative workplace conditions and comprises only 2.5% (n = 5) of the HR workforce, or 0.00017% of all workplace participants (30,000).

The gender of the HR workforce respondents was primarily female (63.1%; n = 70), with males (23.0%, n = 26), with the remaining (13.5%; n = 15) staff not falling into these categories or preferring not to say (Figure 1). This demographic composition is not significantly different to other HR departments in Australia ( $\chi_{(1,2)} = 0.0366$ ; p = 0.8482). The ABS (2016) data showed that 72% of HR professionals were female, averaging 37 years. Similarly, in the United States, women account for 70% of HR professionals and have an average age of 46.6 years (Zippia, 2023). In Anglicare, the dominant combined demographics are represented by women aged 25-54 years, with males aged 45-54 years forming the fourth largest cohort (Figure 1). The smallest combined age cohort was the 18-24-year-old roles. This indicates that middle-aged females, likely with substantial work experience and solid job understanding, continue to dominate the human resource workforce domain.

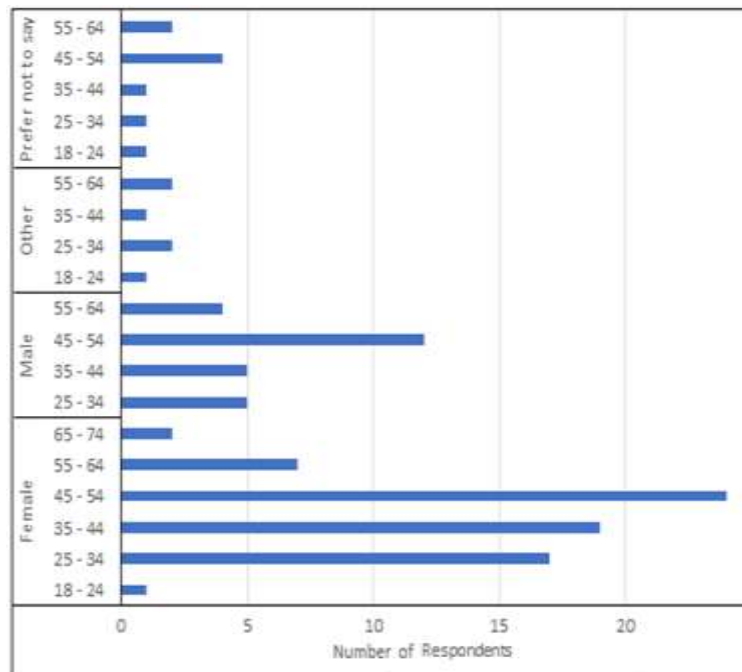

Figure 1: Survey respondent demographic composition by stated gender identity and age (n = 111).

The organizational structure comprises 33.9% of HR respondents who were positioned at level 2 (n = 38) with duties to deliver special projects, such as HR diversity policies (Figure 2). Considered middle management (Levels 3-4) consisted of 34.8% (n = 39) of all employees, and executive management (Level 5) was 23% (n = 26) of HR professionals. Only 8% (n = 9) of HR professions were administrative and support roles (Figure 3). While there were more females at each level, a significant difference in the gender proportions at different hierarchal levels exists within Anglicare ( $\chi_{(4,3)} = 11.21$  p = 0.1898; Figure 3). This gender differential reflects gender proportions of the HR industry: higher administrative levels being 38.4% (n = 10) of level 5s and upper-middle management, level 4, representing 32% (n = 8) of the workforce. In contrast, women (64.3%; n = 9) and those who preferred not to say and other (28.5%; n = 4) were overly represented in lower-middle management, with men only holding 7.1% (n = 1).

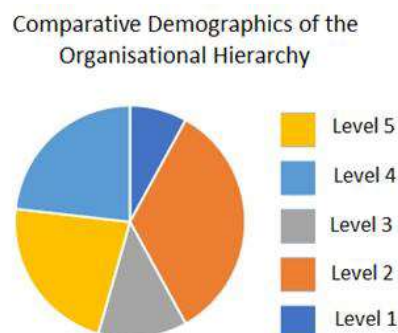

Figure 2: The proportion of HR professionals by administrative level (n = 111).

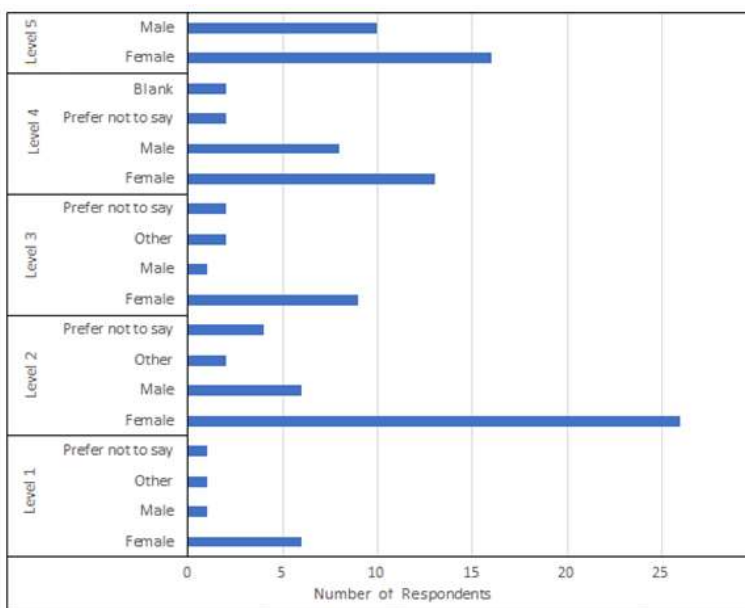

Figure 3: Survey respondent demographic composition by stated gender identity and organization position (n = 112).

Regarding educational attainment, 49% held an undergraduate university degree (Figure 4). In contrast, only 23% of the respondents were master-level tertiary educated, with one holding a PhD. Of the respondents, 18% had non-university post-secondary education, and 8.7% had no post-secondary education (Figure 4). The educational demographics of the survey are not reflective of the broader HR industry in Australia ( $\chi_{(1,6)} = 12.2135$ ;  $p = 0.0067$ ), where 14.3% of employees held postgraduate qualifications, 35.9% held a bachelor's degree, 28.4% had post-secondary education, and 21.4% had no formal post-secondary education. Furthermore, both Anglicare and the Australian National average differed from the United States educational standard of HR professionals ( $\chi_{(2,10)} = 32.7359$ ;  $p < 0.001$ ), where HR professionals had higher levels of education, with only 3% of HR professionals not holding post-secondary qualifications (Figure 5). The low numbers of 18–24-year-olds indicate the time taken to attain competency in HR and are reflected in the time to achieve the educational attainment required for respondents' positions.

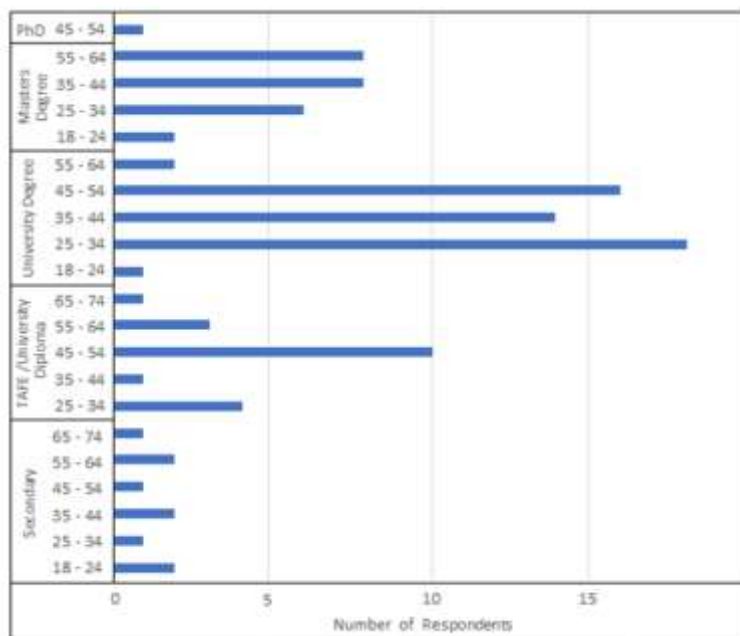

Figure 4: Survey respondent demographic composition by educational attainment and age (n = 113).

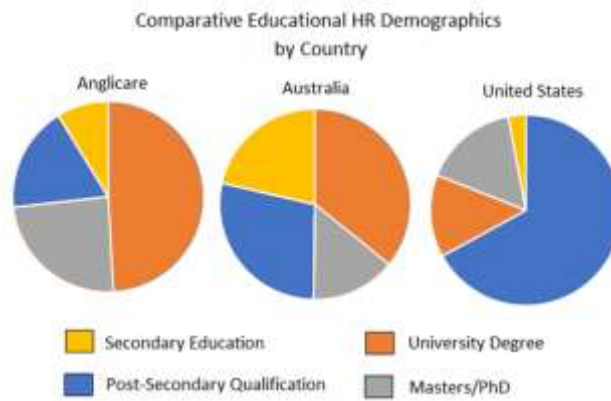

Figure 5: A comparison of educational attainment in the HR profession showing the Australian and the United States contrasted with Anglicare (source: ABS (2016) and Zippia (2023)).

There were differences in the educational attainment between the genders in the Anglicare HR department (Figure 6). The educational attainment of HR staff significantly differed proportionally by gender ( $\chi_{(2,10)} = 70.9283$ ;  $p < 0.001$ ). Women had lower educational attainment than men, with 70.3% having some level of university training, while 90.9% of men had university degrees. In contrast, 'other' and those who do not wish to be identified had reduced educational attainment, with 66% of the cohort with tertiary qualifications (Figure 7). Only one respondent held a PhD, and this male was 45-55 year old cohort.

The term of employment varied significantly with gender ( $F_{(2,60)} = 0.0037$ ;  $p = 0.008$ ). Males held their positions for an average of 7.9 years ( $n = 21$ ); in contrast, females held their positions for an average shorter period of 4.2 years ( $n = 68$ ), and those who did not identify or other were highly mobile, averaging only 1.9 years in their positions ( $n = 7$ ).

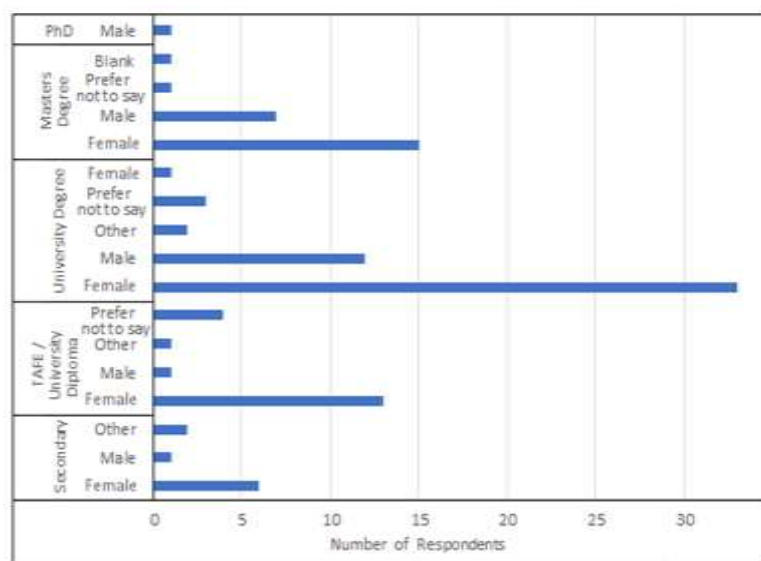

Figure 6: Survey respondent demographic composition by educational attainment and gender (n = 104).

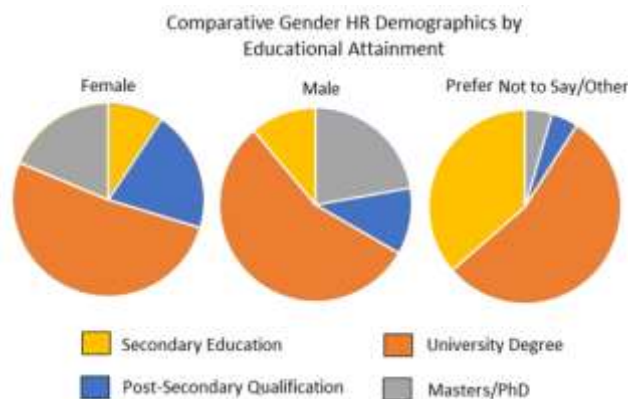

Figure 7: Comparison of educational attainment in the HR profession by gender within Anglicare.

The promotion within the organization represents only 34.5% of respondents' staff currently in their roles (n = 33; Figure 8). Of the male respondents, 38.4% (n = 10) had been promoted during their tenure; in contrast, 31.4% (n = 20) of those identified as female were promoted. Those individuals who did not identify as male or female or preferred not to say had a rate of promotion of 6.7% (n = 2). The time taken to be promoted from within the organization averaged 4.2 years of organizational experience prior to being promoted and varied with gender identity, with females promoted faster (3.9 years) than males (5.0 years) and those not identifying as male and females promoted after four years.

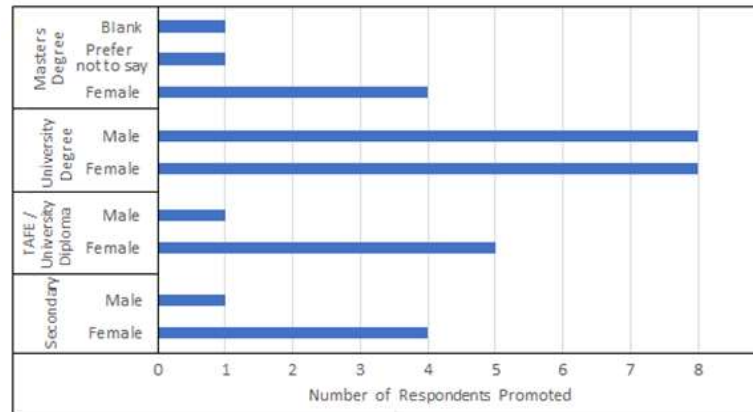

Figure 8: Survey respondent demographic composition by promotion, educational attainment, and stated gender identity (n = 33).

## DISCUSSION

### Organizational Management Implications

The Australian historical gender pay gap has significantly affected women's net wealth throughout their working lives (Wischer, 2023). While there has been a move to facilitate the normalization of male parental leave and the rise of flexible work environments, women remain the dominant caregivers, restricting their overall income-earning potential, notwithstanding the compensation legislated for (Wischer, 2023). In the present study, females were overrepresented in lower-middle management, while males dominated upper management. This disproportionality in gender at differing management ranks would naturally indicate that there is an individual gender pay gap when the average of each gender is calculated. Notwithstanding this disparity in pay, the findings indicate that Anglicare promotes women 22% faster within the HR division of the organization. However, there is a gendered bias with women leaving the organization 48% faster than males. As positions become available, males have served longer within the organization and, therefore, have an implicit advantage of experience when senior workplace roles become available.

Furthermore, males tend to work longer than women, which can be attributed to the increased care roles and less flexibility in hours worked typical of non-executive positions (Parjoleanu, 2020). This has the effect of entrenching males at the higher management levels and distorting the gender/wage average. Therefore, enabling the bridging of the gender pay gap would facilitate the need for higher gender-based pay grades, and this would lead to reverse discrimination which is illegal under Australian workplace laws (Schuster et al., 2022; Wischer, 2023).

Women are attracted to occupations with a core caring role, including caregiving/nurturing occupations and support/administrative occupations like human resources. The findings of this study support this with a female-dominated workforce (Purvanova & Muros, 2010). This female-dominated workplace is actually generating decreased workplace satisfaction for women; this reduces their perceived personal level of fulfilment that women self-report (Jung & Welch, 2022). Furthermore, women had higher rates of stress than males, although this may not always be statistically significant (Marcassa, 2022). Given that women are more predisposed to experience workplace emotional exhaustion, these factors have flow effects that can cause negative workplace conditions to develop, such as burnout (Mullins & Lindeman, 2022).

The gender workplace has differing dimensions for each gender; males and females differ in their understanding of the culture of wellness and self-compassion (Rotenstein et al., 2021). Two identified gendered factors mitigate negative workplace conditions, such as burnout, and the normalization of workplace experiences: the need for personal fulfilment and the ability and ability to control workplace scheduling (Mullins & Lindeman, 2022). Women are also pressured to balance work-life commitments, leaving them more prone to stress and burnout (Marcassa, 2022). While women tend to be underrepresented at a higher level of administration, they tended to be highly overrepresented at lower management, and these gender demographics were consistent with this study and highlighted the leaky pipeline effect where women leave organizations before they reach their full potential (Marcassa, 2022). The limited opportunity for advancement for women of 4.2 years, notwithstanding this time being a faster progression period than males, may also explain the reduced time of tenure of females because of a lack of personal fulfilment (Rotenstein et al., 2021).

### Theoretical Implications

One of the leading causes of the gender pay gap is often linked to the workplace dynamics of job security and the casualization of staff (Wisner, 2023). However, this study found that pay gaps can be linked to a lack of retention of female staff; this may reflect the inflexibility within the workplace to enable the employee to mediate the care roles that women often play in family structures (Bergmann et al., 2019; Wisner, 2023). Furthermore, HR departments are stressful environments, with employees at the forefront of organizational change and disruption, as well as having the challenging role of maintaining discipline within the workforce, and this leaves HR personnel at higher risk of hindrance stressors such as organizational politics and interpersonal conflict (Blake Hargrove et al., 2016). The lack of retention of women as they are promoted within an organization, and therefore progress to higher levels of administration, may reflect the increase in organizational stress that they are exposed to, and this can lead to increased rates of burnout, compassion fatigue and other workplace negative conditions (Blake Hargrove et al., 2016).

### Future Implications

This study indicates that men tend to remain in their positions longer, and this reflects the gendered gap in coping with work vicissitudes (Arman, 2020). Maximizing the retention of women at higher administrative levels within the workplace requires targeted support, particularly for senior HR workers who often are at the coalface of workplace trauma and conflict. Added organizational support can reduce the effects of the leaky pipeline and build resilience within the upper management, and women in particular (Marcassa, 2022).

### CONCLUSION

This study shows the importance of suitable demographics as a potential data-sectioning tool in quantitative surveying. It shows that demographics can help the surveyor to understand better whether data capture is representatively spread across the targeted domain. It shows how even a few aspects of demographic data capture, such as age and job duration, can offer beneficial insights - particularly when undertaking quantitative studies.

This study highlights the gender disparity in the human resources profession workforce. Although dominated by females, there is a gender pay gap per capita within the profession, with a bias towards males. This can be explained by the middle and upper management structure, with a bias towards males, which can be explained in two ways: the increased propensity of females to suffer from negative workplace conditions, particularly when they feel professionally unfulfilled, leading to increased staff turnover rates and males remaining in their positions longer than females. This disparity persists despite an implicit promotional bias towards females who are promoted faster than males. This failure to retain females leads to gender bias favoring males in upper management. In human resources, the problem, therefore, is not one of female recruitment but instead of retention and fulfilment issues that lead to females exiting the promotion pipeline, increasing the proportion of males in upper management through time despite positive discrimination.

### ACKNOWLEDGMENT

Data for this study is held by James Cook University, Australia, and stored within PhD Student Suzie Pont's personal data repository files.

### REFERENCES

- Arman, G. (2020). Bystander intervention in the context of abusive supervision: Effects of power distance orientation and gender. *Journal of Work and Organizational Psychology*, 36(2), 111-124.
- Australian Government (2016 amended 2023). Labour Market Insights Human Resource Professionals. Retrieved from: <https://labourmarketinsights.gov.au/occupation-profile/human-resource-professionals?occupationCode=2231> (accessed 28 May 2023).
- Bergmann, N., Scheele, A., & Sorger, C. (2019). Variations of the same? A sectoral analysis of the gender pay gap in Germany and Austria. *Gender, Work, and Organization*, 26(5), 668–687.
- Blake Hargrove, M., Hargrove, D., & Becker, W. S. (2016). Managing Stress: Human Resource Management Interventions for Stress and Eustress. *Journal of Human Resources Education*, 10(2), 25–38.
- Burns, K. E. A., Pattani, R., Lorens, E., Straus, S. E., & Hawker, G. A. (2021). The impact of organizational culture on professional fulfillment and burnout in an academic department of medicine. *PloS One*, 16(6), e0252778–e0252778.
- Chandler, N. (2019). Employer attractiveness: a study into the link between demographics of jobseekers and reasons for applying for a position. *Journal of Human Resource Management*, 22(1), 30-45.
- Edgar, F., & Geare, A., (2004). Employee Demographics in Human Resource Management Research, *Research and Practice in Human Resource Management*, 12(1), 61-91.
- Frederick, D. A., Reynolds, T. A., Barrera, C. A., & Murray, S. B. (2022). Demographic and sociocultural predictors of face image satisfaction: The US Body Project I. *Body Image*, 41, 1-16.
- Gonzalez-Morales, M. G., Rodriguez, I., & Peiro, J. M. (2010). A longitudinal study of coping and gender in a female-dominated occupation: Predicting teachers' burnout. *Journal of Occupational Health Psychology*, 15(1), 29-44.

- Hammond, L.-S., & Coetzee, M. (2022). An exploration of factors influencing the retention of senior female employees in a financial services organization. *SA Journal of Human Resource Management*, 20(1), e1–e10.
- Hodson, R. (2004). Work Life and Social Fulfillment: Does Social Affiliation at Work Reflect a Carrot or a Stick? *Social Science Quarterly*, 85(2), 221–239.
- Jung, H., & Welch, E. W. (2022). The Impact of Demographic Composition of Social Networks on Perceived Inclusion in the Workplace. *Public Administration Review*, 82(3), 522–536.
- Ma, X., & Macmillan, R. B. (1999). Influences of Workplace Conditions on Teachers Job Satisfaction. *Journal of Educational Research*, 93(1), 39–48
- Mabaso, C. M., Maja, M. T., Kavir, M., Lekwape, L., Makhasane, S. S., & Khumalo, M. T. (2021). Talent retention strategies: An exploratory study within the consulting industry in Gauteng province, South Africa. *Acta Commercii*, 21(1), 1-14.
- MacLeod, M. R., & Hunter, D. G. (2021). The impact of age demographics on interpreting and applying population-wide infection fatality rates for COVID-19. *INFORMS Journal on Applied Analytics*, 51(3), 167-178.
- Marcassa, S. (2022). Gender Differences in Burnout Syndrome and Perceptions of Gender Equality in Research Organisations. *Proceedings 5th International Conference on Gender Research 2022*, pp. 130-138.
- Morrison, P. A., & Abrahamse, A. F. (1996). Applying demographic analysis to store site selection. *Population Research and Policy Review*, 15, 479-489.
- Mullins, C. H., & Lindeman, B. (2022). Ending the burnout gender gap in surgery. *The American Journal of Surgery*, 223(4), 608–608.
- Parjoleanu, R. (2020). Gender Payment Disparities in the European Union. *Economics and Applied Informatics*, 26(3), 43-52.
- Purvanova, R. K., & Muros, J. P. (2010). Gender differences in burnout: A meta-analysis. *Journal of Vocational Behavior*, 77(2), 168–185.
- Recuero, L. H., & Segovia, A. O. (2021). Work-Family Conflict, Coping Strategies and Burnout: A Gender and Couple Analysis. *Revista de Psicología Del Trabajo y de Las Organizaciones*, 37(1), 21–28.
- Rotenstein, L., Harry, E., Wickner, P., Gupte, A., Neville, B. A., Lipsitz, S., Cullen, E., Rozenblum, R., Sequist, T. D., & Dudley, J. (2021). Contributors to Gender Differences in Burnout and Professional Fulfillment: A Survey of Physician Faculty. *Joint Commission Journal on Quality and Patient Safety*, 47(11), 723–730.
- Rotenstein, L., Harry, E., Wickner, P., Gupte, A., Neville, B. A., Lipsitz, S., Cullen, E., Rozenblum, R., Sequist, T. D., & Dudley, J. (2021). Contributors to Gender Differences in Burnout and Professional Fulfillment: A Survey of Physician Faculty. *Joint Commission Journal on Quality and Patient Safety*, 47(11), 723-730.
- Schuster, C., Sparkman, G., Walton, G. M., Alles, A., & Loschelder, D. D. (2023). Egalitarian Norm Messaging Increases Human Resources Professionals' Salary Offers to Women. *Journal of Applied Psychology*, 108(4), 541–552.
- Wischer, K. (2023). Australia's gender pay gap in 2023 -- its causes and promising reforms: Australia's national gender pay gap across public and private sector employers sits at 22.8%, the same as in 2021. This means women earn, on average, \$263.90 less than men each week. *Australian Nursing & Midwifery Journal*, 27(11), 42.
- Zippia (2023). Human Resource Manager Demographics and Statistics in the US. Retrieved from: [www.zippia.com](http://www.zippia.com) (accessed 2 July 2023).

## Enhancing Inbound Tourism through the Taiwan Outdoor Project and AI-Enabled Chatbot Management

Chen-Ho Kuo <sup>1,\*</sup>

\*Corresponding author

<sup>1</sup> HEC Liège Executive Education, Management School- Liège Université, Liège, Belgium, Executive Doctorate in Business Administration EDBA Student, alex.kuo@riversoft.com.tw

### ABSTRACT

In recent years, the global tourism industry has faced unprecedented challenges due to the COVID-19 pandemic. Taiwan, like many other countries, experienced a significant decrease in inbound tourism. However, an innovative project called Taiwan Outdoor emerged, aiming to leverage AI technology and its AI-enabled chatbot to support inbound tourism by providing enhanced services to foreign expatriates stranded in Taiwan. This essay explores the Parkbus service, the Taiwan Outdoor project, and the role of AI-enabled chatbots in promoting Taiwan's outdoor landscapes and tour packages to attract inbound tourists.

Parkbus was introduced as a service to cater to the needs of foreign expatriates stranded in Taiwan during the pandemic. Recognizing the desire for peaceful wellness experiences, Parkbus facilitated convenient transportation to Taiwan's National Parks, allowing customers to engage in hiking and immerse themselves in the serene natural surroundings. By offering minimum services to ensure freedom and flexibility, Parkbus successfully met the demands of its customers.

After three years of compiling customer feedback, the Parkbus team identified the specific needs expressed in these comments. This feedback became the foundation for the Taiwan Outdoor project, a trailblazing initiative that utilizes AI technology to enable more comprehensive services and promote Taiwan's outdoor landscapes and tour packages to attract inbound tourists. The government of Taiwan recognized the potential of this project and awarded it funding to support its execution.

At the heart of the Taiwan Outdoor project is an AI-enabled chatbot. This intelligent virtual assistant utilizes AI technology to provide personalized recommendations, information, and support to inbound tourists interested in exploring Taiwan's outdoor attractions. Through natural language processing and machine learning algorithms, the chatbot analyzes user inquiries and preferences, enabling it to deliver tailored suggestions and assist with trip planning. By leveraging AI, the chatbot can provide real-time updates on weather conditions, trail information, transportation options, and even offer localized recommendations for dining and accommodations.

The AI-enabled chatbot plays a vital role in promoting Taiwan's outdoor landscapes and tour packages to inbound tourists. By harnessing the power of AI, the chatbot acts as a reliable and accessible tour guide, answering queries, providing recommendations, and offering a seamless user experience. It assists potential tourists in understanding the diverse natural wonders of Taiwan, highlights popular hiking trails, suggests off-the-beaten-path destinations, and showcases the unique cultural experiences available. The chatbot's ability to understand multiple languages further enhances its effectiveness in engaging with a global audience.

The Taiwan Outdoor project, with its AI-enabled chatbot, has revolutionized the way inbound tourists discover and experience Taiwan's outdoor landscapes. By combining the convenience of the Parkbus service with the intelligence of AI technology, this innovative initiative effectively promotes Taiwan as a desirable destination for nature enthusiasts worldwide. As the project continues to evolve, the chatbot's capabilities and knowledge base will expand, ensuring an increasingly personalized and immersive experience for inbound tourists. Taiwan's commitment to leveraging AI to enhance tourism highlights its forward-thinking approach and positions it as a leader in leveraging technology to create memorable visitor experiences.

*Keywords:* Inbound tourism, Taiwan Outdoor project, AI-Enabled Chatbot management, Parkbus service



## INTRODUCTION

In 2020, Riversoft<sup>1</sup> ventured into the operation of the 1.0 Parkbus service, which provides outdoor hiking and transportation services for foreign visitors in Taiwan. Nowadays, Riversoft has sold over a hundred packages and served thousands of foreign travelers, thereby boosting the transportation and tourism guide industry in Taiwan.

The global tourism industry is embracing the opportunities for post-pandemic recovery. According to the analysis compiled by the Environmental Resource Center, short-term "tourist" itineraries are no longer the mainstream. Instead, there is a growing demand among travelers for "slow-and-sweet local tours" and "eco-tourism" experiences that allow them to relax both physically and mentally. What is more, a survey on outdoor leisure activities favored by Europeans and Americans reveals that running, fishing, hiking, and cycling are their top four outdoor recreational activities. The global outdoor leisure market is projected to reach a scale of 2.5 trillion US dollars by 2026. With the prevalence of mobile smart devices, Riversoft is introducing an upgraded version, the Taiwan Outdoors 2.0 mobile service.

The target audience for the Taiwan Outdoors service includes foreign travelers who enjoy outdoor activities and suppliers of outdoor leisure travel components. One of the most time-consuming and labor-intensive aspects of planning and communicating during outdoor leisure trips in Taiwan is the itinerary planning and communication process. The interaction between consumers and suppliers can be divided into three stages:

### Search and Considerable Stage

Foreign travelers face fragmented outdoor information, language barriers, and difficulties in obtaining information about outdoor itineraries in Taiwan. Component suppliers lack personnel with foreign language capabilities, and their official accounts are not conducive to engaging with foreign customers using their preferred software.

### Purchase and Action Stage

Foreign travelers need to make separate bookings for different travel components, resulting in poor convenience. Customer service is not genuinely intelligent, resulting in prolonged waiting times. Small and medium-sized component suppliers face insufficient manpower in customer service, repetitive question responses, and reduced work efficiency.

### Post-purchase Adjustment Stage

The outdoor itineraries of foreign travelers are influenced by weather conditions. Taiwan has significant weather differences compared to Europe and the US, and there is a lack of equipment information discussion platforms. Component suppliers have limited climate information, making it challenging for them to anticipate changes in orders and adjust itineraries to meet demand.

## LITERATURE REVIEW

To effectively explore the scope of intelligent automation in the context of tourism, this literature review will begin by providing definitions of artificial intelligence, robotics, and the internet-of-things. These definitions are essential for understanding the key concepts related to intelligent automation. In the tourism industry, intelligent automation plays a significant role in various applications, including Inbound Tourism, the Taiwan Outdoor Project, AI-Enabled Chatbot Management, and Parkbus service.

While artificial intelligence and robotics were initially closely intertwined, they have now evolved into distinct areas of research, each making remarkable progress (Rajan & Saffiotti, 2017). It is important to recognize that AI researchers often prioritize top-down reasoning and may overlook the physicality and embodiment aspects of automation. This approach has led to the emergence of what is known as "disembodied AI," where the physical components and interaction with the environment are not fully considered.

The concept of AI was first introduced in the 1950s by John McCarthy, who defined it as "the science and engineering of making intelligent machines, especially intelligent computer programs" (McCarthy, 2007). According to Russell and Norvig (2010), different definitions of AI revolve around two dimensions — the thought process behavior and the human performance rationality. In the context of exhibiting human-like behavior, machines require six capabilities, which correspond to the sub-disciplines of AI: natural language processing, knowledge representation, automated reasoning, machine learning, computer vision, and robotics (Russell & Norvig, 2010). These capabilities are essential in various applications, such as Inbound Tourism, the Taiwan Outdoor Project, AI-Enabled Chatbot Management, and Parkbus service.

<sup>1</sup> Riversoft is a company which possesses a strong foundation in large-scale software engineering technology and extensive industry experience.

In the field of tourism, researchers have recently shown interest in artificial intelligence (AI), robotics, and automation. However, their contributions thus far have been mainly limited to describing current applications and discussing potential future implementations and impacts (Ivanov and Webster, 2019a, Ivanov and Webster, 2019b, Ivanov and Webster, 2019c; Murphy, Gretzel, & Pesonen, 2019; Murphy, Hofacker, & Gretzel, 2017; Tung & Law, 2017; Yeoman & Mars, 2012). The implementation of intelligent automation in tourism is still relatively limited, which has led to empirical studies focusing on analyzing online reviews (Tung & Au, 2018) and conducting experiments involving second-hand experiences with robots (Lu, Ioannou, Tussyadiah, & Li, 2019; Tussyadiah & Park, 2018). These studies aim to explore the transformation occurring in the ways tourism is performed, particularly in the context of Inbound Tourism, Taiwan Outdoor Project, AI-Enabled Chatbot Management, and Parkbus service.

## METHODOLOGY

This paper employs a specific "Design Science Research" approach to do research on Taiwan Outdoor project, AI-enabled Chatbot management, and Parkbus service. In the paper, the approach "Design Science Research" investigates Taiwan Outdoors service's stages for foreign travelers who enjoy outdoor activities and suppliers of outdoor leisure travel components.

### **Project Implementation Strategy**

Regarding the market demand analysis, targeting foreign travelers who enjoy outdoor activities and domestic suppliers of outdoor leisure travel components, the Taiwan Outdoors service addresses the time-consuming and labor-intensive challenges of itinerary planning and communication during outdoor leisure trips in Taiwan. The interaction between consumers and suppliers is divided into three stages below.

#### *The Search and Consideration Stage*

Foreign travelers face fragmented outdoor information, language barriers, and difficulties in obtaining information about outdoor itineraries in Taiwan. Component suppliers lack personnel with foreign language capabilities, and their official accounts are not conducive to engaging with foreign customers using their preferred software.

#### *The Purchase and Action Stage*

Foreign travelers need to make separate bookings for different travel components, resulting in poor convenience. Customer service is not genuinely intelligent, resulting in prolonged waiting times. Small and medium-sized component suppliers face insufficient manpower in customer service, repetitive question responses, and reduced work efficiency.

#### *The Post-Purchase Adjustment Stage*

The outdoor itineraries of foreign travelers are influenced by weather conditions. Taiwan has significant weather differences compared to Europe and the US, and there is a lack of equipment information discussion platforms. Component suppliers have limited climate information, making it challenging for them to anticipate changes in orders and adjust itineraries to meet demand.

### **Project Implementation Strategy and Plan**

This project aims at using technology to address pain points in outdoor itinerary planning, connect the industry chain for business opportunities, and combine NLP/Chatbot, dynamic content display, and weather data programming technology through mobile devices to create the Taiwan Outdoors 2.0 mobile service. This innovative service involves interactive Q&A collection of outdoor leisure attraction information through mobile chat, making my company the industry information provider authorized by the Central Weather Bureau to use API to integrate weather data. The project combines our leading technology with industry partners to showcase the innovative decision-making process and service flow of outdoor smart travel.

## RESULTS AND DISCUSSIONS

Based on Riversoft's previous experience in the outdoor tourism industry, I have identified the primary pain points faced by foreign tourists engaging in outdoor activities in Taiwan. I have devised solutions for these issues through three categories of intelligent travel services below.

### **Integrated Cross-Platform Travel Advisory Service**

#### *The Previous Problem*

The information about outdoor activities in Taiwan was fragmented, often relying on personal bloggers or social media influencers for sharing. This led to uncertain and unreliable information, and the traditional click-based approach to gather information about outdoor attractions in Taiwan was not effective, particularly for foreign tourists. Language barriers also hindered effective communication even with translation tools in place.

#### *The Solution*

To address this, I propose a novel approach using "chat" interactions instead of traditional "click" interactions to access information about Taiwan's outdoor activities. By implementing content tagging technology, traveler preferences can be analyzed, and recommendations from partner suppliers can be matched and showcased, thereby increasing exposure. Additionally, real-time translation in three languages breaks down language barriers.

### **Benefits**

Foreign travelers will gain direct access to information about Taiwan's outdoor activities through chat interactions, including multimedia content and insights from fellow travelers. With support for three languages, this approach resolves the issue of fragmented information for foreign tourists. Content tagging technology also enables tailored recommendations, enhancing user engagement and satisfaction.

### **Intelligent Travel Guidance and Process Automation**

#### ***The Previous Problem***

Even sizable online travel platforms required foreign outdoor enthusiasts to separately purchase different travel components, hindering the seamless acquisition of comprehensive information and payment. Insufficient customer service manpower on the supplier end led to prolonged online waiting times, reducing customer satisfaction.

#### ***The Solution***

To tackle these challenges, I propose utilizing intelligent consultation and dynamic packaging services, which encompass customized orders, diverse payment options, and smart customer service. This simplifies processes and enhances convenience for travelers in planning their activities. Through "generative AI dialogue interactions," I aim to provide responses to various types of user questions, leveraging strong semantic analysis capabilities.

#### ***Benefits***

With an all-inclusive chatbot service, travelers can directly order required travel components without page redirects and customize their itineraries according to personal preferences. The generative AI technology ensures more human-like responses to a wide range of questions, enhancing the quality of customer service. This approach significantly reduces customer service response times and alleviates manpower issues for travel businesses.

### **Weather Services and Enhanced Value Marketing**

#### ***The Previous Problem***

Weather fluctuations significantly impact outdoor activities, especially considering the diverse climate compared to Western countries. While objective weather summaries were available online, integrating weather forecasts with itineraries lacked precision, limiting assistance with attire and equipment preparation.

#### ***The Solution***

To address this, I propose integrating exclusive weather data from the meteorological bureau to provide more accurate outdoor weather information within a 3-kilometer radius. This information will be combined with online "OOTD Weather Report Communities" and offline "Brand Collaborations and Placements" to offer suitable attire recommendations and boost local outdoor equipment brands.

#### ***Benefits***

The incorporation of weather open data will provide travelers with precise outdoor weather information within a 3-kilometer radius. The weather-based attire information community will facilitate interactions between travelers and local businesses, allowing them to share weather and attire insights. This approach enhances convenience, safety, and engagement for foreign tourists.

By implementing these solutions, Riversoft aims to address the identified pain points and enhance the overall experience for foreign tourists engaging in outdoor activities in Taiwan. This multifaceted approach harnesses AI technology to streamline information access, optimize travel planning processes, and provide valuable weather insights, contributing to Taiwan's allure as a top destination for outdoor enthusiasts worldwide.

### **Explanation of Value Creation**

The Riversoft team has continued its integration of information systems in the tourism industry, and while we have our Taiwan Outdoors mobile service platform to promote Taiwan's outdoor attractions, we predominantly integrate with upstream B2B suppliers in the tourism-related industry. Through our technological enhancements and platform services, we assist them in accessing and capitalizing on C2C (foreign travelers) outdoor tourism opportunities. The following outlines the value created for our suppliers and foreign travelers through this technological integration, as the figure 1 below.

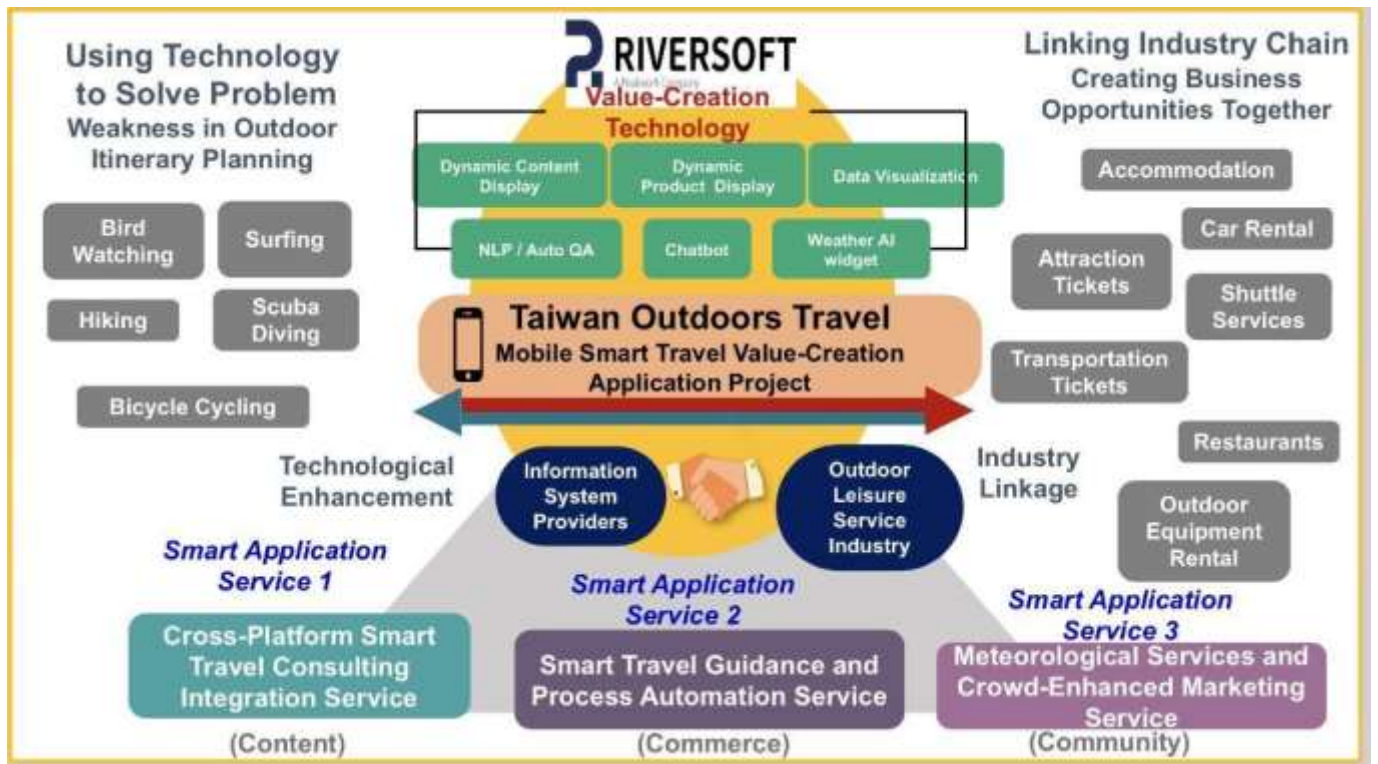

Source: This study.

Figure 1: Value-Creation Technology of Taiwan Outdoor Project by Riversoft Inc.

The exclusive fusion of weather data has enabled a reduction of weather forecasts from a 15-kilometer radius to a precise 3-kilometer radius at the destination. This not only significantly enhances the safety value of outdoor tourism but also serves as a practical demonstration of the synergy between weather data and industry applications.

The Taiwan Outdoors intelligent travel platform adds value to travel suppliers by supporting mobile devices, allowing digital tools for order management with just a smartphone and an account. Real-time translation breaks language barriers, introducing a novel channel for international outdoor leisure and tourism prospects.

Foreign travelers who utilized the Taiwan Outdoors service platform enjoyed improving convenience compared to the traditional "Chat" method of conducting business. The implementation of generative AI technology allows for a wide variety of traveler inquiries to be addressed promptly and effectively, resulting in a truly innovative and intelligent customer service experience.

### Advantages of Project Execution

With 15 years of experience in information systems integration in the travel industry, Riversoft possesses expertise, proprietary system development technology, and substantial capacity, attracting investment from international travel and technology partners. The already operational Parkbus primarily offered mountain trekking and transportation services to foreign visitors, uniquely nurturing and driving the development of domestic outdoor tourism. This project extends from the familiar preferences of foreign travelers for outdoor experiences with Parkbus, as well as insights into their travel component requirements, to a broader scope under the Taiwan Outdoors mobile travel service theme.

Through Riversoft's network, the Riversoft team connects local travel component suppliers in the domains of dining, accommodation, transportation, activities, entertainment, and shopping. Supported by our international technology network, alliances, and marketing teams, we expedite the promotion of our services to targeted foreign travelers. Notable partners include the American Institute in Taiwan, the Canadian Chamber of Commerce, and the Taipei Community Services and Educational Foundation. Through their channels and resources, we accelerate the reach of our services to both resident and overseas foreigners, forming a robust Taiwan Outdoors smart travel team. The platform's support for three languages is particularly beneficial for small and medium-sized domestic outdoor travel suppliers, overcoming language barriers that have previously hindered their access to the foreign tourism market. The research project collectively enhances Taiwan's international market visibility.

## Qualitative Results and Anticipation

Table 1: Key Performance Indicators and Target Value of Taiwan Outdoor Project  
Unit: Thousand New Taiwanese Dollars

Required Indicator	Key Performance Indicators	Target Value
	Attract the number of enterprises/stores to participate (stores)	180 stores
	Number of service users (person)	72,000
	Derivative output value (thousand New Taiwanese Dollars)	69,803 thousand New Taiwanese Dollars
	Consumer or store service satisfaction (points)	85 points
	Total mobile payment transactions (thousand New Taiwanese Dollars)	12,636 thousand New Taiwanese Dollars
	Mobile smart value creation application (item) (Mobile smart value creation category)	3 items
Optional Indicator	Adding new members	20,000 people
	New clients	5,000 people
	Reducing the average waiting time for customer service	110 minutes/per time
Extra Bonus Condition	International expansion indicators - At least 3 marketing in North America, Europe, and Japan The number of exposures to international printed literature for customers	300,000 people
	The average of salary growth (%)	6%

Source: This study.

### Qualitative Effects of Operational Benefits

#### *Enhanced Market Competitiveness through Integration of Cross-Category Tourism Suppliers*

To meet outdoor tourism demands, Riversoft establishes collaborations among cross-category component suppliers, offering a diverse array of product and service combinations. This approach provides consumers with a range of meaningful and diverse choices. Particularly for foreign travelers, they can conveniently book and experience various travel products on a single platform, obtaining all required travel components in one go. This eliminates the need to navigate and search through different travel component webpages, enhancing user-friendly interface and service experience, thus boosting market competitiveness of our products and services.

### ***Mobile Phone Integration with AI Customer Service to Reduce Pressure on Customer Support and Improve Operational Efficiency***

Overturning the traditional post-sale customer service process for travel products, such as contact via phone and email, our approach significantly reduces customer wait times. With the integration of AI customer service, the workload of human agents is effectively decreased. Furthermore, utilizing natural language processing technology, customer inquiries are analyzed to provide the most fitting answers, while the accumulated question-answer data continuously improves through machine learning, enhancing response accuracy and customer satisfaction, ultimately improving operational efficiency.

### ***Exclusive Integration of Weather OPEN API Data, Emerging as a Service Highlight***

Recognizing the impact of weather on outdoor trips, we obtained exclusive authorization for weather data from the Central Weather Bureau. Through API integration and predictive weather technology, we provide more accurate weather information for outdoor destinations, reducing the influence of weather-related disappointments on trips. Additionally, this data can be shared with our partnering travel component suppliers, enabling proactive inventory management in response to changing weather conditions.

### **Industry Benefits**

#### ***Mobile Language Translation Function to Assist Local Tourism Suppliers in Accessing International Tourism Market Opportunities***

Many domestic outdoor tourism component suppliers operate as independent or small-scale businesses, often lacking internationalization and suffering from language barriers. Our mobile smart travel platform bridges these gaps by matching suitable domestic component suppliers to foreign travelers' needs in real-time. Coupled with multilingual translation, this helps overcome language barriers, expand the audience of potential customers, enhance international market visibility, and stimulate business prospects.

#### ***Application Value of Mobile Order Placement to Lower the Digital Barrier for Tourism Industry Operators***

By receiving orders through mobile communication applications, tourism operators can realize digital operations without necessarily adopting dedicated order management systems. This not only significantly reduces associated costs but also, through the integration of mobile devices and communication apps, enables quicker, more convenient, and efficient services. This increases traveler satisfaction and, in turn, market competitiveness.

### **Societal Benefits**

#### ***Reinventing the Tourism Itinerary Planning Process through Mobile Applications***

While Riversoft service primarily targets foreign travelers, local consumers fond of outdoor destinations can also access our mobile platform. Our project innovates the traditional data collection and subscription processes, shifting from a Click-based to Chat-based approach, even though smartphone penetration is high worldwide. Consumers can compare and choose various travel products and services conveniently within the same platform. Moreover, they can ask questions through conversation rather than navigating menus, offering truly tailored customer service information, providing a superior user experience.

#### ***Matching Accommodation and Transportation Services to Solve the Last-Mile Issue in Outdoor Tourism and Enhance Global Visibility of Taiwan's Outdoor Trips***

Taiwan Outdoors' mobile smart travel service deeply understands that many outdoor attractions are either not well-served by public transportation or require private vehicles for access, creating inconvenience for foreign tourists. Consequently, we emphasize transportation mediation, boosting the willingness of foreigners to visit Taiwan. Moreover, as Riversoft service is mobile device-friendly, it reduces the use of physical maps and travel brochures, conserving paper resources. Foreign travelers can also easily learn about local culture, customs, and environmental conservation, propelling not only the tourism industry but also achieving a harmonious blend of cultural, environmental, and economic benefits.

## **CONCLUSION**

In conclusion, the Taiwan Outdoor project, accompanied by the AI-enabled chatbot, has emerged as a transformative force in redefining the way inbound tourists engage with and explore Taiwan's picturesque outdoor landscapes. By synergizing the accessibility of the Parkbus service with the ingenuity of AI technology, this pioneering endeavor has effectively positioned Taiwan as an alluring destination for nature enthusiasts across the globe. As this initiative evolves, the chatbot's capabilities and reservoir of knowledge are set to expand, ensuring a progressively personalized and immersive encounter for inbound tourists. Taiwan's commitment to harnessing AI for enhancing tourism underscores its forward-thinking strategy, establishing it as a vanguard in leveraging technology to cultivate indelible visitor experiences.

The implications of the Taiwan Outdoor research project extend across multiple dimensions in this paper. Firstly, the innovative integration of AI technology with tourism infrastructure enhances service efficiency, enriches customer experiences, and ameliorates operational efficacy, thereby fostering a virtuous cycle of growth in the tourism sector. This approach not only aligns with the post-pandemic trends of personalized, leisure-focused tourism but also underscores Taiwan's dedication to fostering technological advancement in the pursuit of tourism excellence.

Secondly, the platform's integration with AI-driven chatbots affirms the potential of cutting-edge technology to surmount language barriers and facilitate seamless communication between foreign tourists and local businesses. This novel approach not only broadens the reach of Taiwan's tourism offerings but also engenders cultural exchange and enhances cultural understanding among diverse audiences.

Finally, the concerted emphasis on integrating weather data enhances tourist safety, satisfaction, and trip planning, marking a significant stride towards sustainable and informed tourism practices. The integration of meteorological insights with outdoor activities augments Taiwan's allure as a safe and responsible destination, resonating with the evolving preferences of modern travelers who prioritize holistic and well-informed experiences.

In the grand tapestry of Taiwan's endeavor, the Taiwan Outdoor project is a resounding testament to the nation's dynamism, resilience, and progressive outlook. As the tourism landscape continues to evolve, the symbiosis of technology and natural beauty will perpetuate Taiwan's legacy as a destination of choice for discerning travelers seeking authentic and enriching encounters with the outdoors.

## REFERENCES

- Ivanov, S., & Webster, C. (2019a). Perceived Appropriateness and Intention to Use Service Robots in Tourism. In J. Pesonen & J. Neidhardt (Eds.), *Information and Communication Technologies in Tourism* (pp. 237-248). Nicosia, Cyprus: Proceedings of the International Conference.
- Ivanov, S., & Webster, C. (2019b). What Should Robots Do? A Comparative Analysis of Industry Professionals, Educators, and Tourists. In J. Pesonen & J. Neidhardt (Eds.), *Information and Communication Technologies in Tourism* (pp. 249-262). Nicosia, Cyprus: Proceedings of the International Conference.
- Ivanov, S., & Webster, C. (2019c). Robots in Tourism: A Research Agenda for Tourism Economics. *Tourism Economics*. In J. Pesonen & J. Neidhardt (Eds.), *Information and Communication Technologies in Tourism* (pp. 1-21). Nicosia, Cyprus: Proceedings of the International Conference.
- Lu, Y., Ioannou, A., Tussyadiah, I., & Li, S. (2019). Segmenting Travelers Based on Responses to Nudging for Information Disclosure. *eReview of Tourism Research*, 17(3), 394-406. <https://ertr-ojs-tamu.tdl.org/ertr/article/view/524>
- McCarthy, J. (2007). What is Artificial Intelligence? CA: Computer Science Department, Stanford University, Stanford. Retrieved from <http://jmc.stanford.edu/articles/whatisai/whatisai.pdf> (accessed 23 July 2023).
- Murphy, J., Gretzel, U., & Pesonen, J. (2019). Marketing Robot Services in Hospitality and Tourism: The Role of Anthropomorphism. *Journal of Travel & Tourism Marketing*, 36(7), 784-795. <https://doi.org/10.1080/10548408.2019.1571983>
- Murphy, J. C., Hofacker, U., & Gretzel, U. (2017). Dawning of the Age of Robots in Hospitality and Tourism: Challenges for Teaching and Research. *European Journal of Tourism Research*, 15, 104-111. <https://doi.org/10.54055/ejtr.v15i.265>
- Rajan, K., & Saffiotti, A. (2017). Towards a Science of Integrated AI and Robotics. *Artificial Intelligence*, 247, 1-9. <https://doi.org/10.1016/j.artint.2017.03.003>
- Russell, S., & Norvig, P. (2010). *Artificial Intelligence: A Modern Approach*. Englewood Cliff, N.J.: Prentice-Hall, Upper Saddle River.
- Safarzyńska, K., Frenken, K., & van den Bergh, J. C. J. M. (2012). Evolutionary Theorizing and Modeling of Sustainability Transitions. *Research Policy*, 41(6), 1011-1024. <https://doi.org/10.1016/j.respol.2011.10.014>
- Tung, V. W. S., & Law, R. (2017). The Potential for Tourism and Hospitality Experience Research in Human-Robot Interactions. *International Journal of Contemporary Hospitality Management*, 29(10), 2498-2513. <https://doi.org/10.1108/IJCHM-09-2016-0520>
- Tung, V. W. S., & Au, N. (2018). Exploring Customer Experiences with Robotics in Hospitality. *International Journal of Contemporary Hospitality Management*, 30(7), 2680-2697. <https://doi.org/10.1108/IJCHM-06-2017-0322>
- Tussyadiah, I. P., & Park, S. (2018). Consumer Evaluation of Hotel Service Robots. In B. Stangl & J. Pesonen (Eds.), *Information and Communication Technologies in Tourism* (pp. 308-320). Jönköping, Sweden: Proceedings of the International Conference.
- Yeoman, I., & Mars, M. (2012). Robots, Men, and Sex Tourism. *Futures*, 44(4), 365-372. <https://doi.org/10.1016/j.futures.2011.11.004>
- Yu, Q., Yuan, C., Z. Fu, Z., & Zhao, Y. (2012). An Autonomous Restaurant Service Robot with High Positioning Accuracy. *Industrial Robot: An International Journal*, 39(3), 271-281. <https://doi.org/10.1108/01439911211217107>



## Evaluating the Key Factors Affecting Hedonic Motivations of Online Video Game Players

Doarka Das <sup>1,\*</sup>  
Aijaz A. Shaikh <sup>2</sup>

\*Corresponding author

<sup>1</sup> Doctoral Researcher, University of Jyväskylä, Finland, [doarka.d.das@student.jyu.fi](mailto:doarka.d.das@student.jyu.fi)

<sup>2</sup> Senior Lecturer, University of Jyväskylä, Finland, [aijaz.a.shaikh@jyu.fi](mailto:aijaz.a.shaikh@jyu.fi)

### ABSTRACT

Online gaming has established itself as the dominant force in entertainment and social engagement, attracting millions of online gamers worldwide. This study aimed to evaluate the key factors that determine online gamers' behavioral intention to play online video games. We also aimed to study the factors that stimulate online gamers' intentions to play online games and try to establish new possibilities to gain insight into the novel behaviors of adolescents and find out the novel themes. An inductive research approach with a focus group discussion technique was used to collect data from twenty-nine experienced online gamers between April and May 2023. The NVivo 13 application was used to analyze data. The present empirical study identified several themes: competition, socializing, teamwork, sexual harassment, social spaces, cyberbullying, and mental health. The primary conclusion from the research study highlights the significance of hedonic motivations, more specifically the continuous behavior to play online games is explained by the identified themes. This study reveals that the irresistible appeal of immersive virtual realms, exhilarating challenges, and the chance to connect with fellow gamers exert a profound influence on online gamers' engagements. It is worth highlighting that the significance of social interaction has undergone a remarkable expansion, with online gaming platforms now serving as virtual social heavens where players forge deep and meaningful relationships. The research study has significant managerial implications and offers a rich future research agenda.

*Keywords:* Hedonic motivation, online video gaming, continuous intention to play

### INTRODUCTION

The first online game was developed in 1980 by Roy Trubshaw and Richard Bartle at the University of Essex and was called "MUD1 or multiuser dungeon" (Bartle, 2015). This starts the beginning of a new era in the entertainment industry with huge social-economic benefits. Playing a video game over the internet or using any virtual network is called an online video game (Lee et al., 2015). Online gamers connect to online gamers via a must-have internet connection to take part in thrilling multiplayer games. Most common platforms used for playing include PlayStation, Xbox, PC, Laptop, and smartphones. Each platform boasts its own unique online gaming experience providing endless opportunities for players to indulge in their favorite games. Almost eight out of ten people from the total internet population play online video games in some way (Newzoo, 2023). Recent changes in digital and communication technologies have gradually transformed the online gaming industry (Frank et al., 2021). The online gaming sector contributes significantly to leisure-time entertainment products and toys by attracting millions of gamers across the world (Teng et al., 2021). The popularity of online gaming is growing rapidly, and digital gamers are increasingly engaged in different modes of games, e.g., single-player and multi-player online games, under distinct genres such as puzzle, action, and adventure games (Abbasi et al., 2021). The gaming industry is now believed to be bigger than Hollywood and the music industry combined together, the US movie industry is worth \$95.4 billion, whereas the music industry is worth \$28.8 billion (Newzoo, 2021). The video game industry was valued at \$178.4 billion in 2021. According to recent projections, the online video gaming business will be valued at \$268.8 billion by 2023, and it is estimated that there are around 3.24 billion players worldwide (Newzoo, 2021). The online gaming industry's future seems to be convincingly profitable, and market growth will be remarkable in the future (Abbasi et al., 2019; Ari et al., 2020; Merhi, 2016). This industry has witnessed growth due to rapid technological advancements, lower costs, widespread internet use, and improvements in the technical capabilities of phones and tablets (Sharma et al., 2020).

Online gamers' behavior is highly influenced by the attitudes, expectations, and behaviors of others (Habib et al., 2021). In influencing teenagers' behavior, online gaming is a key factor, which impacts their behavior (Quwaider et al., 2019). Online gaming has become incredibly popular among teenagers globally (Teng et al., 2021). The factors influencing players' motivations to play online video games and the factors influencing their behaviors, as well as how such factors influence their motives and behaviors are significant and worth investigating (Ari et al., 2020). Thus, it is important to investigate young players' online gaming behavior, as their consumption patterns can be redefined as compared to previous generations (Priporas et al., 2017). Similarly, psychological, and medical research in the domain of online gaming has represented both positive and negative consequences. In the past, few researchers have conducted research on teenagers' behavior and their participation in online gaming (Jasrotia et al., 2022). No research has explored online gamers' teamwork and team participation experience (Liao et al.,

2020). Current literature has explained that video gaming behavior is studied with distinct outcomes including stress, anxiety, and achievements. However, a gap exists to investigate further (Jamak et al., 2018). From the perspective of user intention studies, online gaming behaviors are interesting areas to explore further (Hollebeek et al., 2022). Future research may be conducted to investigate playful-consumption experience (e.g., imaginal, emotional, and sensory) in determining players' online gaming engagement such as cognitive, affective, and behavioral engagement (Abbasi et al., 2019).

The current empirical study fills this gap and attempts to evaluate the key factors that determine online gamers' (including digital natives and adults) continuous intention to play online video games considering their hedonic values (i.e., perceived enjoyment). The research aims to deepen our understanding of online gamers' intentions to play online games, especially the factors that stimulate their intentions to play digital games. In this study, we focus on hedonic values since the study tries to establish new possibilities to gain insights into novel behaviors of adolescents as well as attempt to improve the pre-existing behaviors developed in the past. Regardless of the growing popularity of digital games, there is a need for rigorous research that how and why online gamers play such games regularly. The study aims to find out the new themes in the areas of online gamers' gaming usage behavior, hence, to achieve these objectives, the study proposes and addresses three research questions as follows.

RQ1. How do the hedonic-related specific motivational factors affect online gamers' continuous intention to play online video games?

RQ2. How does the continuous intention to play online video games affect the usage behavior of online gamers?

RQ3. What are the factors that motivate adults and teenagers to continuously play online video games?

The findings of this research article aim to support the industry's efforts to improve the quality of online gaming while also boosting the digital games' capacity to positively affect the community in the form of healthy game concepts. The results will enable the high-tech industries to produce new technological innovations and creative end-user applications in the areas of online gaming. Further, the research outcomes will help the game developers understand players' preferences and behaviors by improving online gamers' engagement and experiences. The findings of this empirical research will help managers and researchers to improve their knowledge of online video gaming.

This article is organized as follows: We present the study's literature review, followed by the research methodologies. The study findings are then presented. Finally, the article discusses the study's significance, implications, and limitations, as well as future research directions.

## LITERATURE REVIEW

The global online gaming sector will exceed USD 300 billion in the next five years (Nigam, 2022). Playing and gaming have been considered essential elements of humans' daily lives (Durak et al., 2023; Hamari et al., 2015). Games have been considered an essential part of teenagers and adults since their childhood; however, it seems different for modern world generations who engage in virtual and digital games, where they play with known and unknown players (Alanko, 2023). Online video games are becoming the most famous sort of games played internationally (Özçetin et al., 2019; Ghețău, 2021; Thakur, 2021; Rudolf et al., 2020; Huang et al., 2019).

Playing online games is commonly perceived as addictive behavior of players, consequently, researchers are putting their efforts into understanding this phenomenon (Hew et al., 2023). Understanding online gamers' intentions to play online video games and their game-playing behavior have become essential topics for game developers, marketers, organizations, and gadget manufacturers (Ari et al., 2020). Ari et al., conducted a research study to understand the online gaming behavior of users in the light of social cognitive theory and U&G theory. Online video game designers, marketers, and other stakeholders must know the factors that stimulate the players' intentions and behaviors to play online video games.

The emergence of mobile multiplayer online battle area (MOBA) games has enabled players to experience cooperation and competition among players (Hew et al., 2023). Hedonic in games, relates to individuals' degree of pleasure, emotional satisfaction, and enjoyment derived from playing a video game (Hollebeek et al., 2022). The intentions of online gamers to continue playing online games have gained significant attention, as the key stakeholders in this industry drive substantial benefits from a better comprehension of underlying factors that drive such factors (Ramírez-Correa, 2019). Fulfillment of the hedonic needs of players can be achieved through a variety of game-related components, including game narrative, visual appeal, competitive play, intellectual stimulation, and socializing among others. Consequently, hedonic factors of games have a significant influence on players' motivation and decisions related to games (Sharma et al., 2020). In the last few years, online video gaming has transformed into a popular kind of entertainment and an intrinsic component of online gamers' everyday lives across the globe. Nonetheless, research into the popularity of such online gaming is still in its early stages.

The focus of research on online video games has been on their adverse impacts, and such games are blamed for spreading violence and aggressive behavior (Mercier & Lubart, 2023). Previous research conducted on players has centered on in-game branding, advertising, and the propensity to purchase gaming products in the physical realm (Nigam, 2022). The advent of online features has rendered the gaming industry more attractive by enabling players from diverse geographical locations to play the same game together at the same time (Albatati, et al., 2023). The involvement of online gamers in video game playing is subject to various factors that can be examined from diverse viewpoints.

Despite higher costs associated with game developments, it has been noticed that market players in the gaming industry invest heavily to maintain profitability, and it is important to promote players' intention to continue playing online video games for revenue generation through several means such as advertising, subscription, and microtransactions (Liew et al., 2022). There are limited research studies in the literature that focus on the hedonic aspects of players. However, some of these studies have emphasized hedonic factors, including the contribution of perceived enjoyment to the formation of players' game-related motivations (Hamari et al., 2015; Abbasi et al., 2019; Ari et al., 2020).

While reviewing the literature, it is discovered that a lot of research has been done on online video gaming in the areas of stress, risk, addiction, mental illness, anxiety, and depression. Exposing a significant literature gap, however, it is unclear what are the novel factors that influence the continuous intentions of adults and teenagers to play online video games. Understanding why players play online video games is and will continue to remain critical to explore for researchers (Newzoo, 2023). Contemplating this research study fills the theoretical and methodological gap.

### RESEARCH METHODOLOGY

Designing a research methodology involved careful planning to ensure that we gather meaningful insights and achieve our desired research objectives. Qualitative research offers valuable insights that are challenging to obtain through quantitative measures, as it provides rich and comprehensive descriptions (Azungah, 2018). Respondents are allowed to express their point of view, according to the research objectives, without the investigator putting any preconceived perceptions, experiences, or views on them (Azungah, 2018). Congruently this qualitative research study follows an inductive approach by employing a focus group discussion technique. An inductive approach will help us to find novel themes from the desired FGDs. Such open-ended discussions are beneficial since they offer unique environments where participants can influence one another and impact others in a more authentic way (Krueger & Casey, 2000).

To identify and recruit both male and female participants of different age groups, a combination of purposive and snowball sampling techniques was adopted (Alharthi et al., 2021). Participants were recruited based on their gaming experiences, we set an initial condition that participants must have at least six months of online gaming experience. The sample is intended to represent teenagers and adults, aged between 18-26 years. Teenagers and adults were targeted because they frequently engage in the hobby of playing online video games (Abbasi et al., 2019). The participants were mostly students and had different education and qualifications. This study employed a network-based recruitment strategy, by utilizing professional relations with heads of educational institutes. The initial recruitment phase involved the selection of 7 participants for FGD. Subsequently, the author employed a snowball sampling technique, whereby recommendations from the initial three participants were used to recruit additional participants.

For FGDs we chose the perfect and conducive environment, they were conducted in quiet and free from distraction places so that our participants feel a sense of comfort and can contribute as much as possible. Over the period of two months, in total twenty-nine participants' data were collected through face-to-face interviews, which included why and how approach to infer online gamers' insights. Respondents were briefed about the objectives of the research, the admission criteria, their right to leave, and the privacy implications of the information gathered during open discussion. Audio conversations were tape-recorded and transcribed. Hence four successful focus group discussion sessions were conducted physically with experienced online video game players, in the presence of moderator and facilitator. Online video game players were free to speak in any regional languages i.e., Sindhi and English.

NVivo is extensively employed in qualitative research which improves the qualitative research process, quickly analyses queries, and broadens the analytical options. Congruently the well-known qualitative data analysis software NVivo 13 is employed for this empirical study (Alharthi et al., 2021). The coding process was managed by the corresponding author who conducted several queries.

### FINDINGS

According to Hanafizadeh & Shaikh (2021), this research study also analyzed the manifest content of data, as we couldn't access latent content (such as silence, sighs, and laughter), due to the utilization of an open-ended questions approach during the data collection process. NVivo 13 application was utilized to identify themes from 29 participants' interview transcripts. A study of the demographic characteristics of the individuals who participated in the study (as shown in Table 1) reveals that most of the participants were female (55.17%), and (44.83%) of the respondents were male. Approximately 51% of the participants were between the ages of 18-20, with 44% between the ages of 21-23, and the remaining 3.45% were in the age bracket of 24-27. All respondents were students by profession. Table 1 summarizes the demographic characteristics of the participants. While selecting respondents, one essential factor was their online gaming experience, which was set to a minimum of six months of playing experience. 11 out of 29 had 3 to 4 years of gaming experience (37.9% of total sample size), followed by 10, who had 5 to 6 years of gaming experience (34% of total sample size). While answering the question of their favorite game, most of the participants answered it as PUBG Battleground (formerly known as Player Unknown's Battleground) game, 41% of the participants responded that they play PUBG game, followed by Free Fire, GTA Vice City, and Call of Duty.

The most frequently used platform for online video game playing is smartphones. Since smartphone platforms are portable, easier, and more convenient. On average every participant briefed us that they play online video games daily and spend two to

three hours a day. In case they don't get time for games, they feel dissatisfied and try to find time for games. Sometimes their relations with siblings and relatives are negatively affected due to excessive game playing time.

The present empirical study identified several themes such as competition, socializing, teamwork, sexual harassment, social spaces, cyberbullying, escapism, and mental health. Female participants reported both general and sexual harassment in online video games. In some instances, female participants disguise their identity and gender, to avoid being recognized and harassed by male counterparts. Female participants further explained that; we are being harassed frequently while playing online games, especially in the multiplayer form of games such as PUBG and Free Fire.

Table 1

Table 1: Demographic profile of the study participants

No.	Characteristics	N	Percentage %
1	<i>Gender</i>		
	Male	13	44.83
	Female	16	55.17
2	<i>Age</i>		
	18-20	15	51.72
	21-23	13	44.83
	24-27	1	3.45
	28-30	0	0.00
3	<i>Gaming Experience</i>		
	1 to 2 years	7	24.14
	3 to 4 years	11	37.93
	5 to 6 years	10	34.48
	7 to 8 years	1	3.45
4	<i>Favorite Game</i>		
	PUBG	12	41.3
	Free Fire	4	13.79
	GTA Vice City	3	10.34
	Call of duty	2	6.90

### The Social Side of Play

Players communicate and socialize with each other in several ways. Socializing allows the gamers to connect, collaborate, and help each other during challenging tasks and levels. It was found that most of the players play multi-player online games for the reason of connecting and expanding their friends' network so that they can have formal and informal discussions and gossip. Participants quoted that while they are playing with their friends' circle, they get more enjoyment and happiness. Congruently, the socializing factor is more rewarding and enjoyable in games. Players share text messages and have voice chats while playing online games, and they get a platform to connect with different cultures and countries people around the world. Here are some insights from the discussions:

*If I talk about my favorite game, I play PUBG game. But I play Roblox and Free Fire also. I prefer the multiplayer type of game and I prefer smartphones because they are easy and convenient. I have been playing online games for 2 years and I play until I get tired. The reason why I play these games is that they provide me with a platform to connect with friends and I like to make new friends. I like to talk to fellow players during games (Female, 18-20, student)*

*When there are teammates, we put speakers and mic on and chat with each other. We sit late at night and enjoy ourselves. It is an amazing experience to talk about winning streaks and tips with fellow game players (Male, 18-20, student).*

*Online games enhance my friends' circle. After games we sit in restaurants and gossip with each other, we get a chance to meet in real life too (Male, 18-20, student).*

In response to questions asked, related to helping and chatting during the game, we got insights that helping and chatting during gameplay is important. Because it gives them help and support to win several types of tournaments in games.

*I want to quote an example, when my friend or teammate gets knocked out, then he gets into a suspicious mood, so from one angle if we cannot see enemies, then they guide us the way and suggest the team in the right direction. But when you are in a winning situation and your friends are speaking a lot then you forget to follow footsteps and hence your chance of losing increases, so it depends sometimes chatting during the game is meaningful and sometimes not (Male, 18-20, student).*

*I think it is important to make new friends. Sometimes we get united through online video games such as siblings and cousins in remote areas (Female, 21-23, student).*

*We get a chance to make new friends from other countries too. I am sharing an interesting example. When I started playing the game, initially, we were 5 friends, but gradually we grew to 10 and now we are 15 friends. Playing online games helps us to connect with people and increase our network. (Male, 18-20, Student).*

### **Gaming In Fear**

It is unfortunately common to know that almost all female players who participated in our research objectives have experienced both general and sexual harassment during game-playing in different ways. Female players frequently receive unwanted sexist messages and comments. During in-depth discussions with female participants, we came to know that male players send explicit messages to fellow female players and create a hostile environment. Here are some insights from the participants:

*I feel stress-free when I play online games. But we girls feel insecure while playing games with strangers. I sometimes disguise my gender and name and play games. If I show that I am a female player, people start searching me on social media, send friend requests, and sometimes harass me while game playing (Female, 18-20, student)*

*I used to play online games a lot. I am sharing an incident with you; I was playing the multiplayer type of game PUBG a few months back. One day I received a friend request on my Facebook account from the boy, who was my classmate at university. He said that you are an expert in PUBG and thanked me for helping him in giving revive. And after a few days, he texted me on messenger saying that you are very beautiful, and he even wrote me those three magic words. I was very angry and blocked him immediately (Female, 21-23, student)*

Some of the female participants reported such unwanted incidents in the game, but they think that no action is taken against such harassment cases.

### **From Passion to Paycheck**

We got insights from the discussion that there are monetary incentives for qualifying rounds and winning certain tournaments in games. Participants reported that players earn recognition and significant income by playing online video games. Here are some views of participants:

*Yes, I feel motivated when I win over my friends, and this also motivates me to play games. It is important for me to accumulate badges and ranks in the game. So that I can show them to my friends. We don't discuss personal issues, if we do then conversation becomes boring, so we do discuss general things such as battle passes, and about new characters (Female, 18-20, student).*

*You know for me games lower the stress level, and this motivates me to play more. For me, it is important to be well-known in the game because it boosts confidence among friends. More often I accept challenges and win games (Male, 21-23, student).*

## **DISCUSSION**

Digital technologies have revolutionized the way we access and utilize services, providing us with unparalleled convenience and flexibility. With the advent of portable and wearable devices such as smartphones and smartwatches, we can now access services anytime, anywhere, with ease and efficiency (Suyunchaliyeva et al., 2021). Similarly, digital technologies have a profound impact on the online video gaming industry. The online gaming industry stands out as remarkably diverse, compared to other entertainment sectors, boasting a multitude of segments that contribute to its overall growth. From traditional PC and console gaming to the immersive arcade experience, and the ever-thriving world of mobile gaming, this industry encompasses a wide range of avenues that fuel its continuous expansion.

This present study makes a valuable contribution to the existing body of knowledge on online video gaming, by identifying novel themes in the areas of online gamers' gaming usage behavior. Additionally, this study examines the hedonic-related motivational factors that motivate adults and teenagers to continuously play online video games. This study also investigates the potential impact of continuous intention to play online video games on the usage behavior of online gamers. Employing the inductive research approach with the help of NVivo 13 applications, some novel themes were identified.

Our study aims to address the research question RQ1. How do the hedonic-related specific motivational factors affect online gamers' continuous intention to play online video games? RQ2. How does the continuous intention to play online video games affect the usage behavior of online gamers? RQ3 What are the factors that motivate adults and teenagers to continuously play online video games?

### **Theoretical Implications**

Hedonic-related motivational factors influence a player in several ways for playing online video games. For example, a participant in a focus group discussion revealed that making new friends is my motivation behind playing online games, it gives me happiness and enjoyment while increasing the existing number of friends. It is fun! And I have built lasting friendships with one of my USA friends.

Playing online video games most of the time makes life problematic with siblings, parents, and relatives, and badly impacts one's mental health and sleep time. Current study findings suggest that our identified themes such as harassment, and mental health demotivate some female players from playing online video games, hence they disguise and stop sharing their identity and gender with other male players while playing. Further, the analysis of existing literature suggests that research on continuous intention to play online video games is influenced by hedonic motivational factors. Those include enjoyment, happiness, competition, escapism, and socializing. We also found that our identified themes such as socializing, competition, and escapism are central and recurring themes. The main findings of this study are that enjoyment and happiness are fundamental aspects that stimulate players' intentions to play online video games. This is evaluated by another study Ramírez-Correa (2019) that describes enjoyment as an important factor behind playing online video games. Hence our results are consistent with those of the studies and investigation (Hamari et al., 2015; Abbasi et al., 2019; Sharma et al., 2020).

### **Managerial Implications**

The industry has undergone remarkable growth and transformation in recent years, fueled by technological advancements and evolving online gamers' preferences. As a result, managers within this sector must be astute and strategic in their decision-making to navigate this landscape successfully. The research offers valuable insights to managers and marketers seeking to influence young and adult players to play online video games. The present study has significant managerial implications. Firstly, the findings underscore the significance of hedonic motivational factors with happiness, enjoyment, socializing escapism, and competition, which play key roles in playing online video games. Hence, in order to cater to the fast-changing needs and preferences of users, managers are required to adopt a user-centric approach. This entails placing utmost importance on enhancing user gaming experience and engagement by means of user-friendly interfaces, responsive customer support (especially harassment victims' users), and personalized gaming experience. Furthermore, managers must allocate resources towards the acquisition and analysis of data, as well as actively seek users' feedback, in order to consistently enhance the game design and content in a way so that players can enjoy and like games more. In addition to that managers must prioritize the top-notch captivating content to effectively attract and retain players. They need to stay ahead of the emerging gaming trends and craft that perfectly aligns with players' preferences.

This study has uncovered disturbing truths: participants' data is being leaked, their gaming accounts are being hacked, and their years of hard-earned ranks and history are being lost. To make matters worse, these accounts are being misused and never returned to their rightful original owners. Players use the report option in the game and complain about such incidents, but they revealed that no action is taken by relevant game regulators. So, keeping in view such concerns, game designers must confidently implement robust security measures to effectively protect user data from any potential breaches and cyberattacks. Similarly, it is imperative that managers confidently comply with data protection regulations to guarantee the utmost respect for player privacy. Managers must actively engage with players, attentively listen to their valuable feedback, and promptly address any concerns they may have. Moreover, they must proactively implement highly effective content moderation strategies to effectively combat toxic behavior and harassment within the gaming community.

### **Limitations And Future Research Directions**

The essential strength of this research lies in its emphasis on the key factors that determine the online gamers' (teenagers` and adults`) continuous intention to play online video games considering hedonic values (i.e., perceived enjoyment). However, several research limitations need to be addressed in the future. Online gamers more often encounter challenges associated with toxicity, harassment, and online abuse. It is imperative for future research to undertake a comprehensive investigation into the underlying causes of these behaviors and to ascertain efficacious strategies for their mitigation. This research emphasizes qualitative data collected through FGDs; hence it is imperative to explore alternative research methodologies in the future to augment the outcomes of this study. Future research is recommended to understand the impact of several other demographic factors. In addition to identified themes, there is a need for future research on harassment, and cyberbullying themes. The results achieved through these themes open new avenues for future research in this direction.

## **CONCLUSION**

The online video gaming industry has undeniably emerged as the most profitable industry surpassing all other entertainment industries over the last decade. Playing online video games is an increasingly popular type of leisure activity among young and adult users in comparison to TV, music, and other entertainment activities. Not only do online games provide a thrilling and enjoyable experience, but they also alleviate the stress and anxiety levels of players. The sheer joy and happiness derived from these digital games are unparalleled. Moreover, online video games provide a unique platform for social interaction, enabling individuals to connect and socialize with others regardless of their physical location. This aspect of gaming has revolutionized the way people socialize, fostering new friendships and connections that transcend geographical boundaries. However, it is necessary to acknowledge that excessive gaming habits can lead to the development of obsessive behavior, mental health issues, and strained relationships with siblings, parents, and relatives.

It is an obligation for game developers to prioritize the protection of female players. Females are particularly vulnerable to harassment and are often targeted by male players. Therefore, it is essential to implement measures that safeguard the rights and well-being of female gamers, ensuring they can enjoy their gaming experience without fear of harassment or mistreatment. It is

our collective responsibility to create a safe and inclusive gaming environment for all players, irrespective of their gender. By prioritizing the protection of female players and promoting a healthy gaming culture, we can ensure, that the online gaming experience remains enjoyable, fulfilling, and free from any form of harassment or discrimination.

## REFERENCES

- Bartle, R. A. (2015). Multi-User Dungeons (MUD s). *The International Encyclopedia of Digital Communication and Society*, 1-8.
- Lee, J., Lee, J., Lee, H., & Lee, J. (2015). An exploratory study of factors influencing repurchase behaviors toward game items: A field study. *Computers in Human Behavior*, 53, 13-23.
- Newzoo. (2023). Newzoo's Global Gamer Study Report. Newzoo. Retrieved from <https://newzoo.com/resources/trend-reports/global-gamer-study-free-report-2023> (accessed 29 August 2023).
- Frank, B., Herbas-Torricco, B., & Schvaneveldt, S. J. (2021). The AI-extended consumer: technology, consumer, country differences in the formation of demand for AI-empowered consumer products. *Technological Forecasting and Social Change*, 172, 1-15.
- Teng, V. N., Manaf, A. R. A., Hamzah, M. R., Yusoff, H. A. M., Hussin, H., Ismail, A., & Ahmad, Y. (2021, May). Factors contributing to online gaming addiction: A cross-sectional survey among university students. *In AIP Conference Proceedings* (Vol. 2339, No. 1, p. 020144). AIP Publishing LLC.
- Abbasi, A. Z., Shah, M. U., Rehman, U., Hlavacs, H., Ting, D. H., & Nisar, S. (2021). The role of personality factors influencing consumer video game engagement in young adults: A study on generic games. *IEEE Access*, 9, 17392-17410.
- Newzoo. (2021). Gen Z Gamers: Key Insights Report. *Newzoo*. Retrieved from <https://newzoo.com/resources/blog/gen-z-gamers-key-insights> (accessed on 15 August 2023).
- Abbasi, A. Z., Ting, D. H., Hlavacs, H., Costa, L. V., & Veloso, A. I. (2019). An empirical validation of consumer video game engagement: A playful-consumption experience approach. *Entertainment Computing*, 29, 43-55.
- Ari, E., Yilmaz, V., & Dikec, B. E. (2020). An extensive structural model proposal to explain online gaming behaviors. *Entertainment Computing*, 34, 100340.
- Merhi, M. I. (2016). Towards a framework for online game adoption. *Computers in Human Behavior*, 60, 253-263.
- Sharma, T. G., Tak, P., & Kesharwani, A. (2020). Understanding continuance intention to play online games: the roles of hedonic value, utilitarian value and perceived risk. *Journal of Internet Commerce*, 19(3), 346-372.
- Habib, R., White, K., Hardisty, D. J., & Zhao, J. (2021). Shifting consumer behavior to address climate change. *Current Opinion in Psychology*, 42, 108-113.
- Quwaider, M., Alabed, A., & Duwairi, R. (2019). The impact of video games on the players behaviors: A survey. *Procedia Computer Science*, 151, 575-582.
- Priporas, C. V., Stylos, N., & Fotiadis, A. K. (2017). Generation Z consumers' expectations of interactions in smart retailing: A future agenda. *Computers in Human Behavior*, 77, 374-381.
- Jasrotia, S. S., Kamila, M. K., Chib, S., & Mishra, H. G. (2022). Role of engagement in online gaming: a study of generation Z customers. *Digital Creativity*, 33(1), 64-76.
- Liao et al. (2020). Impact of real-world need satisfaction on online gamer loyalty: perspective of self-affirmation theory. *Computers in Human Behavior*, 91-100.
- Jamak, A. B. S. A., Abbasi, A. Z., & Fayyaz, M. S. (2018). Gender differences and consumer videogame engagement. *In SHS Web of Conferences* (Vol. 56, p. 01002). EDP Sciences.
- Hollebeek, L. D., Abbasi, A. Z., Schultz, C. D., Ting, D. H., & Sigurdsson, V. (2022). Hedonic consumption experience in videogaming: A multidimensional perspective. *Journal of Retailing and Consumer Services*, 65, 102892.
- Nigam, A. (2022). Online gaming and OTT consumption: An exploratory study of generation Z. *Journal of Promotion Management*, 28(4), 420-442.
- Yildiz Durak, H., Haktanir, A., & Saritepeci, M. (2023). Examining the Predictors of Video Game Addiction According to Expertise Levels of the Players: The Role of Time Spent on Video Gaming, Engagement, Positive Gaming Perception, Social Support and Relational Health Indices. *International Journal of Mental Health and Addiction*, 1-26.
- Hamari, J., Keronen, L., & Alha, K. (2015, January). Why do people play games? A review of studies on adoption and use. *In 2015 48th Hawaii International conference on system sciences* (pp. 3559-3568). IEEE.
- Alanko D. (2023). The Health Effects of Video Games in Children and Adolescents. *Pediatrics in review*, 44(1), 23-32.
- Özçetin, M., Gümüştas, F., Çağ, Y., Gökbay, İ. Z., & Özmel, A. (2019). The relationships between video game experience and cognitive abilities in adolescents. *Neuropsychiatric disease and treatment*, 1171-1180.
- Ghețău, C. (2021). Voice Communication Usage Among Video Game Players and Its Effects on Users Perceived Anonymity. *Journal of Media Research-Revista de Studii Media*, 14(39), 93-101.
- Thakur, D., Shergill, K., Kaur, G., Kaur, S., Abrol, D., Singh, H., & Gill, A. (2021). Gaming addiction to Massively Multiplayer Online Games (MMOGs) and Quality of Life. *Indian Journal of Forensic Medicine & Toxicology*, 15(1).
- Rudolf, K., Soffner, M., Bickmann, P., Froböse, I., Tholl, C., Wechsler, K., & Grieben, C. (2022). Media consumption, stress and wellbeing of video game and eSports players in Germany: the eSports study 2020. *Frontiers in sports and active living*, 4, 665604.
- Huang, C. L., Yang, S. C., & Hsieh, L. S. (2019). The cyberbullying behavior of Taiwanese adolescents in an online gaming environment. *Children and Youth Services Review*, 106, 104461.



- Hew, J. J., Lee, V. H., T'ng, S. T., Tan, G. W. H., Ooi, K. B., & Dwivedi, Y. K. (2023). Are online mobile gamers really happy? On the suppressor role of online game addiction. *Information Systems Frontiers*, 1-33.
- Hollebeek, L. D., Abbasi, A. Z., Schultz, C. D., Ting, D. H., & Sigurdsson, V. (2022). Hedonic consumption experience in videogaming: A multidimensional perspective. *Journal of Retailing and Consumer Services*, 65, 102892.
- Ramírez-Correa, P., Rondán-Cataluña, F. J., Arenas-Gaitán, J., & Martín-Velicia, F. (2019). Analysing the acceptance of online games in mobile devices: An application of UTAUT2. *Journal of Retailing and Consumer Services*, 50, 85-93.
- Mercier, M., & Lubart, T. (2023). Video games and creativity: The mediating role of psychological capital. *Journal of Creativity*, 33(2), 100050.
- Albatati, B., Liu, F., Wang, S., & Yu, M. (2023). Emotions and online gaming experiences: An examination of MMORPG gamers from India and the United States. *Computers in Human Behavior*, 107900.
- Liew, T. W., Gan, C. L., Tan, S. M., Koh, Y. P., & Yeo, S. F. (2022, December). How Social Influence and Hedonic/Utilitarian Outcome Expectations Affect Continuance Intention to Play Online Games. In *2022 International Conference on Digital Transformation and Intelligence (ICDI)* (pp. 161-167). IEEE.
- Azungah, T. (2018). Qualitative research: deductive and inductive approaches to data analysis. *Qualitative research journal*, 18(4), 383-400.
- Krueger, R., & Casey, M. (2000). *Focus Groups: A Practical Guide for Applied Research* 3rd Edition Sage Publications London.
- Alharthi, M., Alamoudi, H., Shaikh, A. A., & Bhutto, M. H. (2021). "Your ride has arrived"– Exploring the nexus between subjective well-being, socio-cultural beliefs, COVID-19, and the sharing economy. *Telematics and Informatics*, 63, 101663.
- Hanafizadeh, P., & Shaikh, A. A. (2021). Developing doctoral students'/researchers' understanding of the journal peer-review process. *The International Journal of Management Education*, 19(2), 100500.
- Suyunchaliyeva, M. M., Nautiyal, R., Shaikh, A. A., & Sharma, R. (2021). The use of mobile payment systems in Post-COVID-19 economic recovery: Primary research on an emerging market for experience goods. *Sustainability*, 13(24), 2-19.

## Exploring Bibliometric Perspectives on Data Culture in Scholarly Discourse

Sunday A. Olaleye <sup>1,\*</sup>  
Akwas G. Adusei <sup>2</sup>

\*Corresponding author

<sup>1</sup> Senior Lecturer, Jamk University of Applied Sciences, Jyväskylä, Finland, sunday.olaleye@jamk.fi

<sup>2</sup> Doctoral Researcher, University of Oulu, Oulu Finland, akwasi.adusei@oulu.fi

### ABSTRACT

Data culture refers to an organization's prevailing attitudes, beliefs, behaviors, and practices concerning data and its utilization. It encompasses the organization's data collection, analysis, sharing, and decision-making approach. A robust data culture is achieved over time but requires a concerted effort by leadership and employees. This study overviews data culture, encompassing organizations' and institutions' attitudes, behaviors, and data-related practices. It highlights the study's exploration of data culture's dimensions and significance in driving innovation, informed decision-making, and competitiveness. The study mentions the relevance of theories like Schwartz's cultural values in understanding data culture's perception across diverse cultures. The study employed bibliometric analysis to assess data culture research trends and identify gaps. It emphasizes the need for interdisciplinary, global, and longitudinal studies to advance understanding in this field. This study is a comprehensive resource for researchers and practitioners interested in data culture, offering insights and future research directions.

*Keywords:* Data Culture, Big Data, Open Data, Data Literacy, Taxonomy, Bibliometric

### INTRODUCTION

Data culture refers to an organization's prevailing attitudes, beliefs, behaviors, and practices concerning data and its utilization. It encompasses the organization's data collection, analysis, sharing, and decision-making approach. A robust data culture is achieved over time but requires a concerted effort by leadership and employees. It involves fostering a mindset that values data as a strategic asset and recognizes its potential to drive innovation, improve efficiency, and inform strategic planning. A data culture can lead to more informed decision-making, a competitive edge, and better organizational outcomes. Data culture revolves around data awareness, literacy, data-driven decision-making, data collection and quality, data sharing and collaboration, leadership support, data governance, performance measurement, continuous learning, data transparency and data ethics.

The existing literature explores how a data-driven culture within firms impacts their product and process innovation, ultimately leading to improved performance and competitive advantage. The research employs a conceptual model validated with responses from 456 employees using various business analytics tools. The findings emphasize the significant influence of data-driven culture on product and process innovation, enhancing a firm's competitiveness. Leadership support and data-driven culture are moderators, while firm size, age, and industry type are control variables (Chatterjee et al., 2021).

Another study is grounded in organizational information processing theory. It investigates how Big Data Analytics Capability (BDAC) contributes to Green Supply Chain Integration (GSCI), focusing on the role of data-driven decision culture. To validate hypotheses, the study collects two-wave survey data from 317 Chinese manufacturing firms. The results indicate that BDAC positively influences various dimensions of GSCI. Additionally, a data-driven decision culture moderates the relationship between BDAC and green internal integration. The research highlights the potential for firms to leverage BDAC for enhanced GSCI (Liu, Fang, Feng & Gao, 2022).

On the other hand, McCord et al.'s (2021) study addresses the challenge of maintaining data quality in ecological research, particularly in the era of big data. It emphasizes the need for a cultural shift to prioritize data quality as an integral practice in ecological studies. The research introduces a comprehensive data quality framework that can adapt to different collaboration models and ecological data types. This framework aims to foster a culture of data quality in ecological research, ultimately enhancing the reliability and reproducibility of findings. At the same time, the study of Su et al. (2021) concentrates on the adverse effects of secondhand smoke exposure, particularly for expectant mothers in China. It highlights the unique challenges traditional cultural practices pose that may discourage reporting family members' smoking behaviors around pregnant women. The paper proposes an innovative approach to measuring secondhand smoke exposure among expectant mothers in the Chinese context, aiming to improve data accuracy on this critical health issue. The research seeks to inform cancer control measures and reduce cancer risk for expectant mothers in China.

Other studies focus on the data economy through productization and underscore the importance of data access for startups and SMEs, explore the role of data in business decision-making, and emphasize the necessity for further research to bridge the gap

in comprehending the relationship between the data economy and productization. This study adopts a conceptual approach and extends the established theoretical framework of Task-Technology Fit (TTF) (Olaleye & Adusei, 2022a), while Olaleye et al. (2022b) employed quantitative bibliometric analysis of published literature to uncover trends, conceptualization, and future directions in the field of data economy. Using data from 2008 to June 2021 from sources such as Web of Science and Scopus, this study combines FAIR data principles with the data economy, shedding light on its conceptual, intellectual, and social structure and highlighting the strategic importance of data for industry and academia. While offering a steppingstone for future empirical and longitudinal studies, this research emphasizes the relevance of data to society and identifies areas for future exploration in this emerging field.

The Existing research focuses on cultural dimensions and values in health (obesity rates), accounting, entrepreneurship, data economy and work-related contexts but the direct application of these cultural dimensions and values to the domain of "bibliometric data culture" is missing, and there is no mention of how cultural values influence scholarly communication, publishing trends, or citation practices, specifically in bibliometric data culture. While existing research underscores the importance of considering cultural dimensions in various contexts, none explicitly identifies the research gap related to the influence of cultural values on bibliometric data culture. This gap becomes apparent when we realize that, despite the emphasis on culture's impact in other domains, there is a limited exploration of how cultural values affect the scholarly communication landscape, particularly in the context of bibliometric measures.

The study addresses a significant research gap by focusing on the influence of cultural values on scholarly communication activities, publishing trends, citation practices, and dissemination of research findings within the context of bibliometric data culture. Doing so extends the existing literature to a new and critical domain. It leverages cultural psychology, sociology, and data science insights to provide a more holistic understanding of how cultural values intersect with data culture. This interdisciplinary approach allows a richer exploration of the complexities involved.

Understanding the role of cultural values in bibliometric data culture has practical implications for academic institutions, researchers, and funders. It can inform strategies for improving scholarly communication, enhancing the visibility of research findings, and adapting practices that align with cultural values. This study can help international researchers and institutions to navigate cultural differences more effectively. This study of bibliometric data culture addresses a critical research gap by applying insights from cultural values and dimensions to the scholarly communication landscape. This study can potentially advance the research community's understanding of how culture shapes the dissemination of scientific knowledge and can offer actionable insights for stakeholders in academia and research.

Despite the impacts of these academic contributions, more bibliometric studies on data culture still need to be done. Due to this gap, this study intends to investigate the impact of bibliometric data culture on scholarly communication within academic and research communities and answer the following research questions: a). How does the integration of bibliometric data culture influence the behaviors and practices of scholars in terms of their scholarly communication activities, including publishing and citation practices? b). What are the specific trends and patterns observed in scholarly publishing, citation practices, and scholarly communication due to the increasing emphasis on bibliometric measures within academic and research communities? c). How does the prevalence of bibliometric data culture affect the visibility and accessibility of scientific knowledge within scholarly discourse, and how does it impact the dissemination of research findings? These objectives and research questions provide a framework for investigating the role and implications of bibliometric data culture in the scholarly communication landscape. This study gave a theoretical background based on Schwartz's cultural values and follow up with methodology, results, discussion and concluded with theoretical, managerial implications, study limitations and future study.

## **THEORETICAL BACKGROUND**

### **Schwartz's Cultural Values**

Schwartz's theory of basic human values serves as a psychological framework meticulously crafted to decipher the intricacies of human values and their profound influence on behavior, attitudes, and decision-making processes. The cornerstone of this theory is the assertion that a set of universal values lies at the core of human beliefs and behaviors, transcending the boundaries of diverse cultures and societies. Schwartz, the architect of this theory, meticulously identified ten fundamental values, ingeniously organizing them into a circular structure. Individuals, guided by their cultural background, personality, and life experiences, bestow varying degrees of importance upon these values.

Within Schwartz's framework, each value bears unique significance. For instance, self-direction embodies the pursuit of autonomy, creativity, and independent thought, while stimulation embodies the relentless quest for excitement, novelty, and life's challenges. In contrast, hedonism champions the relentless pursuit of pleasure and the cultivation of enjoyable experiences, while achievement places a premium on personal success, competence, and the pursuit of ambitious goals. Power, one of the ten human values, signifies the desire for control, dominance, and influence over others. At the same time, security underscores the importance of safety, stability, and order in an individual's life. Conformity breathes life into human values by representing the desire to adhere to societal norms, rules, and expectations. In contrast, tradition embodies the reverence for preserving cultural and societal traditions and values. As we reach the final stretch, benevolence emerges, grounded in a profound concern for the welfare and well-being of others, and universalism stands tall as the embodiment of a steadfast commitment to social justice, equality, and the welfare of all individuals, often transcending cultural and national boundaries.

Schwartz's theory identifies these ten fundamental values and postulates that they coalesce within a circular structure. This circular arrangement unveils these values' intricate interplay and compatibility, purportedly a universal cultural phenomenon. Two instrumental methods, the Schwartz Value Survey, and the Portrait Values Questionnaire, have been devised to measure these values accurately. Findings from research spanning 82 countries provide compelling evidence to underscore the theory's capacity to transcend cultural boundaries and remain universally applicable (Schwartz, 2012).

The theory posits that these values occupy specific positions within the circular structure, with opposing values at opposite ends of the circle. For instance, self-direction starkly contrasts conformity, while benevolence counters power. This arrangement accounts for the compatibility and conflict between these values. Individuals prioritize these values differently, creating unique value systems that influence their attitudes, behaviors, and decision-making processes. Cultural and social factors, in tandem with personal experiences, play a pivotal role in shaping an individual's value hierarchy. Consequently, Schwartz's theory has been extensively applied in psychology and social sciences. Researchers employ many instruments, including the Schwartz Value Survey (SVS), to assess an individual's value priorities and delve into their far-reaching impact on various aspects of life and society.

In a separate inquiry, scholars delve into the roles played by Schwartz's cultural value types in individual Information and Communication Technologies (ICT) usage across 49 nations. Their research unveils the significant relevance of seven value types in this context. Furthermore, the study reveals that ICT use is more prominent among individuals with higher levels of education, income, employment status, and youth. Additionally, it discerns notable similarities and differences in results between developed and developing nations, thereby shedding light on the profound impact of cultural values on ICT utilization (Bagchi & Kirs, 2009).

Similarly, other researchers explore the complex relationship between obesity rates across various countries and cultural dimensions, such as those delineated by Hofstede and Schwartz, alongside Gross National Income per capita. Their findings illuminate the positive association between individualism and uncertainty avoidance, as per Hofstede's dimensions, and obesity rates. In contrast, long-term orientation exhibits a negative correlation with obesity rates. However, the study does not establish a significant link between Schwartz's cultural values and obesity rates. This research underscores the imperative of considering cultural dimensions when devising strategies to combat obesity (Tekeş et al., 2019). Continuing the trajectory of cultural influences, some scholars seek to uncover the role of cultural conditions, particularly cultural values, in unravelling disparities in accounting practices across nations. In this endeavor, they present typologies of cultural value models put forth by scholars such as Schwartz, Hofstede, and Gray. Furthermore, they elucidate recent studies that employ these frameworks to decipher the profound impact of national culture on the intricacies of accounting practices (Koleśnik, 2013).

Shifting focus, another set of scholars delves into the intricate interplay between individual cultural orientations, rooted in Schwartz's values model, and nascent entrepreneurship. Their investigation reveals that values aligned with open-mindedness and self-direction positively influence nascent entrepreneurship. In contrast, values associated with tradition and security exert a dampening effect on the nascent entrepreneurial spirit. This research sheds light on the multifaceted motivations driving entrepreneurship across diverse cultural landscapes (Alsaad, 2018).

Furthermore, a comprehensive overview of the systematic study of values in psychology emerges. This scholarly exposition, underpinned by Schwartz's theory of basic personal values, delves into the content and structure of values across cultures, the intricacies of measuring values, their origins, and their profound impact on an array of behavioral and societal facets (Sagiv & Schwartz, 2022). In a separate realm, Schwartz (1999) introduces a theory delineating cultural values tailored for cross-cultural comparisons. This theory, substantiated by data from 49 nations, identifies seven types of values distributed along three polar dimensions. These findings provide valuable insights into the cultural value priorities of various nations. Moreover, they rearrange these nations in a two-dimensional space, shedding light on meaningful clusters of culturally akin nations. The research also delves into the far-reaching implications of disparities in cultural values for interpreting the meaning of work. It develops hypotheses that explore the compatibility or conflict between cultural value emphases and work centrality, societal norms regarding work, and the pursuit of various work-related values and goals.

Lastly, Vauclair et al. (2011) conducted a meta-analysis employing the Rokeach Value Survey (RVS) to replicate Schwartz's value structure at the cultural level. Remarkably, their findings confirm the structure of conflicting value types as predicted by Schwartz. Furthermore, they unearth a previously uncharted value type termed Self-Fulfilled Connectedness (SFC). This value type encapsulates profound attachment to others and embodies attributes of self-fulfillment. Impressively, their analysis reveals correlations between SFC and subjective well-being, post-materialism, and socio-economic development indices at the country level. These correlations underscore the connection between SFC and happiness, the pursuit of non-materialistic goals, and the endorsement of values prevalent in societies where basic needs are satisfied. This groundbreaking discovery offers intriguing theoretical perspectives within Schwartz's cultural value theory.

### METHODOLOGY

As organizations and institutions advance their data culture, several challenges persist. One significant challenge is the unequal distribution of data literacy and proficiency among employees. While some possess advanced data skills, others struggle to harness the power of data effectively. This study employed quantitative methodology with bibliometric data analysis and inferred from the existing studies of (Olaleye, 2020; Olaleye, 2023) to anatomized data culture with the lens of academic scholars' contributions.

This study's research design and methodology on bibliometric data culture involved a systematic approach with specific criteria and steps for selecting and evaluating academic papers. The study elaborates on the process to provide a clearer understanding. Initially, the study utilized the Web of Science database for data collection. Web of Science is a well-regarded academic database that grants access to various scholarly publications. The search strategy was crafted with precision to retrieve pertinent papers. Specifically, the study used the search string "data culture" (Topic) and established the following criteria:

The data collection took place on July 14, 2023.

The search was limited to articles or proceeding papers (Document Types).

The study considered publications from 1994 to 2023 (Publication Years) for longitudinal exploration.

The language of publication was restricted to English (Languages).

Given the burgeoning nature of the data culture research domain, the primary focus was articles and conference proceedings. Initially, this search yielded 115 academic papers. However, after applying inclusion criteria, which filtered out non-English papers (two papers in Spanish and one in German) and narrowed the publication years to 1994-2023, the dataset was refined to include 95 papers. These 95 papers constituted the basis for the subsequent data analysis, conducted using specialized tools of VOSviewer (Van Eck & Waltman, 2017) and Biblioshiny (Aria & Cuccurullo, 2017).

As a bibliometric analysis tool, VOSviewer allows users to visualize and scrutinize various aspects of academic papers. This process encompassed examining citation networks, co-authorship networks, and keyword co-occurrence, among other facets. Similarly, Biblioshiny, another bibliometric analysis tool, equipped users with features to delve into bibliometric data, facilitating visualization and exploration.

This study aimed to uncover significant insights from the included 95 academic papers. Specifically, the study sought to understand trends and patterns in scholarly publishing related to data culture, assess the frequency of paper citations, scrutinize author affiliations, and identify potential clusters of research interest. This comprehensive approach enabled the study to paint a detailed picture of the bibliometric landscape in data culture. This study design and methodology were meticulously crafted to provide a structured and rigorous approach to studying bibliometric data culture. The systematic selection of papers, coupled with the application of specialized analysis tools, allowed the study to gain valuable insights and contribute meaningfully to understanding this research domain. The below Figure 1 show the framework for the data collection.

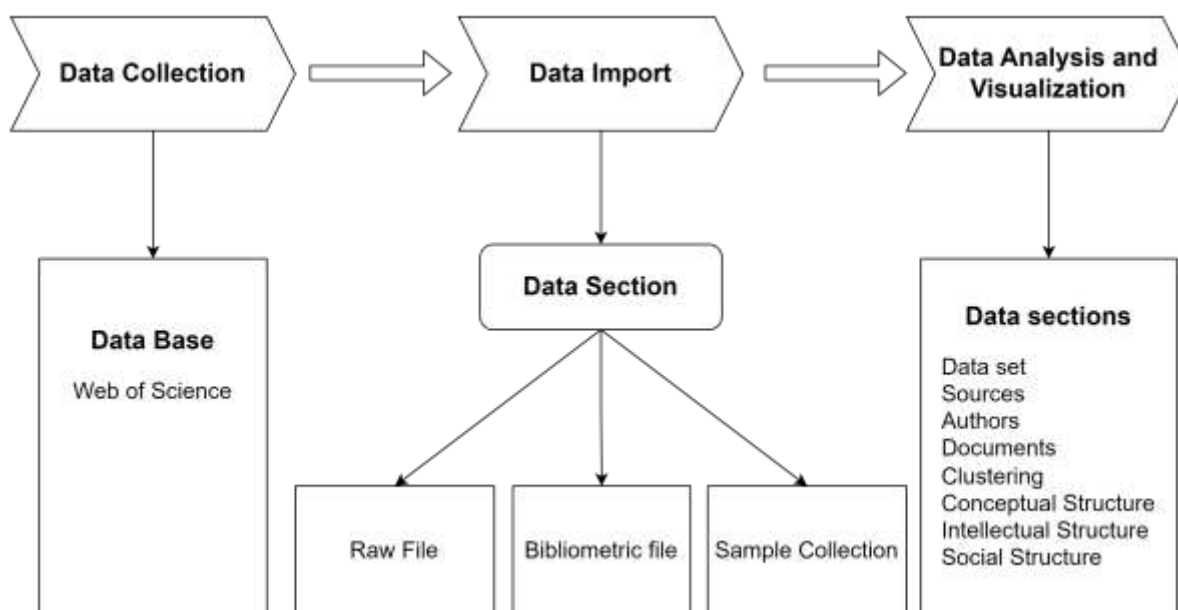

Figure 1: Bibliometric Research Steps Using Biblioshiny and VOSviewer



Figure 2: Descriptive Statistics of Data Culture

**RESULTS AND DISCUSSIONS**

The descriptive statistics of data culture in Figure 2 show 91 sources of journals and conferences, 95 documents consisting of articles and conferences proceedings with annual growth rate of 4.9%. 377 authors contributed to the body of knowledge while only 16 were single-authored and 21.05% had international co-authorship. As the big data era is advancing, also data culture is becoming more relevant, and it is growing steadily.

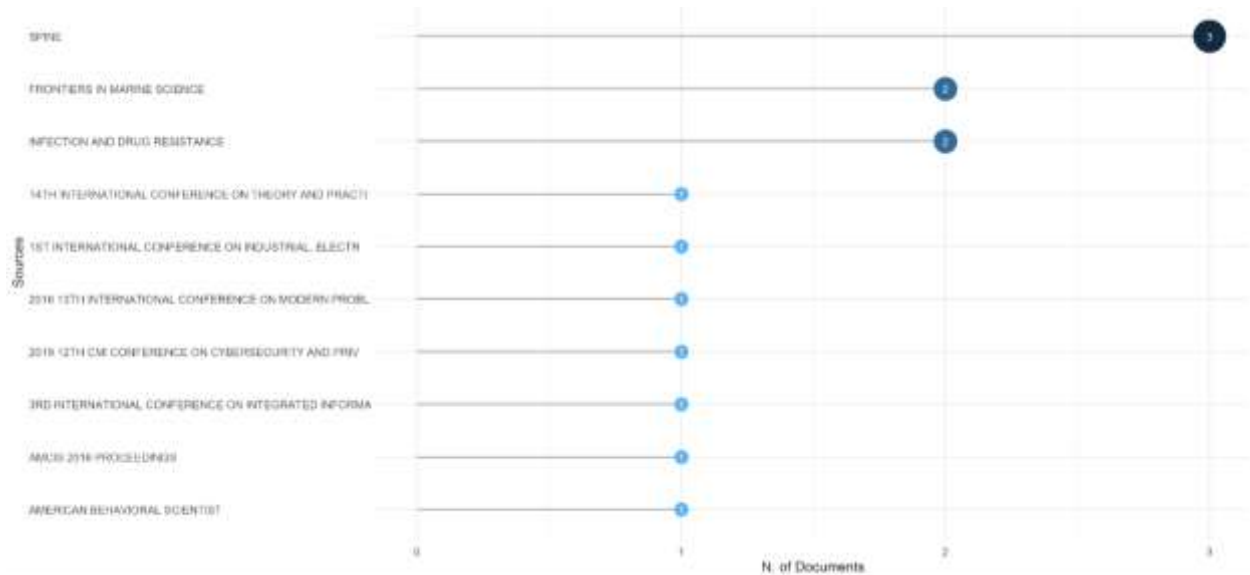

Figure 3: Most Relevant Sources of Data Culture

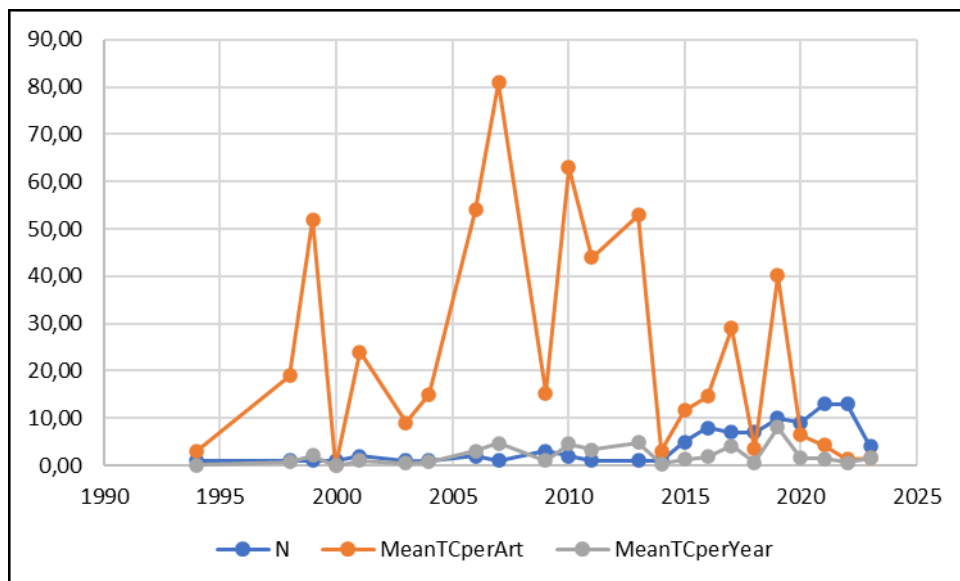

Figure 4: Data Culture publication frequency, mean per article and year

The active authors in the data culture field communicate with their readers through Spine with three publications, *Frontiers in Marine Science* and *Infection and drug resistance* with two publications. All the conferences used by the authors and other journals published one paper each (Figure 3). Data culture is a multidimensional field, and its communication diffusion is still at a lower level. Also, as shown in Figure 4, the highest publication of thirteen papers reflected in 2021 and was repeated in 2022. The earlier 1 publication in 2007 recorded 81 mean total citation per article and 4.76 mean total citation per year. In 2010 there were 63 publications with 4.50 mean total citation per article and 8.04 mean total citation per year. Likewise in 2019, there were 10 publications, 40.2 mean total citation per article and 8.04 mean total citation per year.

Based on the chart in Figure 4, the trends and patterns observed in scholarly publishing in the field of data culture are undulating. The publications were at a low level from 1999 to 2014 but there was a little shift in 2015 with five papers and from then till 2022 there was slight increase in publications.

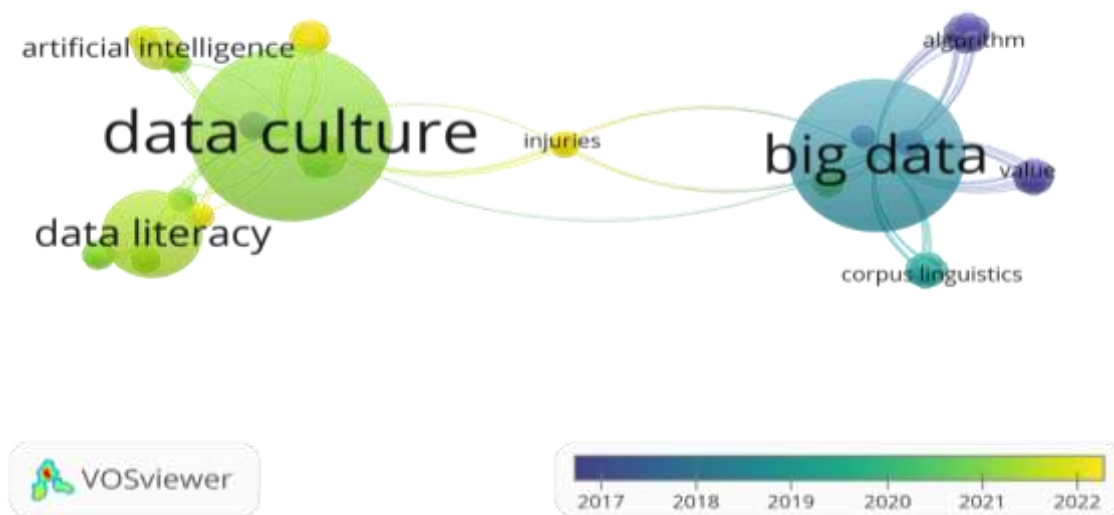

Figure 5: Author's Keywords

Figure 5 shows that the relationship between artificial intelligence (AI), data culture, data literacy, big data, algorithms, corpus linguistics, and injuries can be understood in the context of how these concepts are interconnected and how they can be applied in various domains, including healthcare and injury prevention. Big data are a massive volume of structured and unstructured data from various sources. These data included text, images, videos, and sensor data.

In the context of injuries, big data can be used to collect and analyze large datasets related to injury cases, causes, and prevention methods. These datasets provide valuable insights into injury-prevention strategies. Corpus linguistics is the study of language by analyzing extensive collections of text (corpora). It involves extracting patterns, trends, and information from textual data. In the context of injuries, corpus linguistics can analyze medical records, injury reports, and the healthcare literature to identify common risk factors, trends in injury types, and effective treatments.

AI involves the development of algorithms and models that enable machines to perform tasks that typically require human intelligence such as understanding natural language, making decisions, and recognizing patterns. In the context of injuries, AI can be applied to analyze big data and linguistic corpus datasets. Natural language processing (NLP) techniques can extract valuable information from text data, whereas machine learning models can predict injury risks, suggest preventive measures, or aid in diagnosis and treatment.

Algorithms are step-by-step procedures or rules that are followed to perform specific tasks. For AI and big data, algorithms are crucial for processing and extracting insights from large datasets. In the context of injuries, algorithms can analyze patterns in injury data, identify correlations between factors (e.g., age, location, and activity) and injuries, and develop predictive models for injury prevention.

Data culture refers to the organizational mindset and practices that prioritize the use of data for decision making and problem solving. A robust data culture in healthcare and injury prevention encourages healthcare institutions to collect, share, and analyze data to improve patient care, identify injury trends, and implement evidence-based interventions. Data literacy involves understanding, interpreting, and communicating effectively with data. It involves skills in data analysis, visualization, and data-driven decision-making. Healthcare professionals and researchers need data literacy to understand big data, corpus linguistic analyses, and AI-driven insights related to injuries. Data literacy enables data stakeholders to draw meaningful conclusions and make informed decisions.



The relationship among AI, data culture, data literacy, big data, algorithms, corpus linguistics, and injuries lies in their collaborative use for injury prevention and healthcare improvement. By leveraging AI and data-driven approaches, healthcare researchers can analyze vast datasets, extract valuable insights from textual data, and develop predictive models to reduce the incidence of injuries and enhance patient care. Robust data culture and literacy are essential components of this process, facilitating the effective use of data in healthcare decision-making.

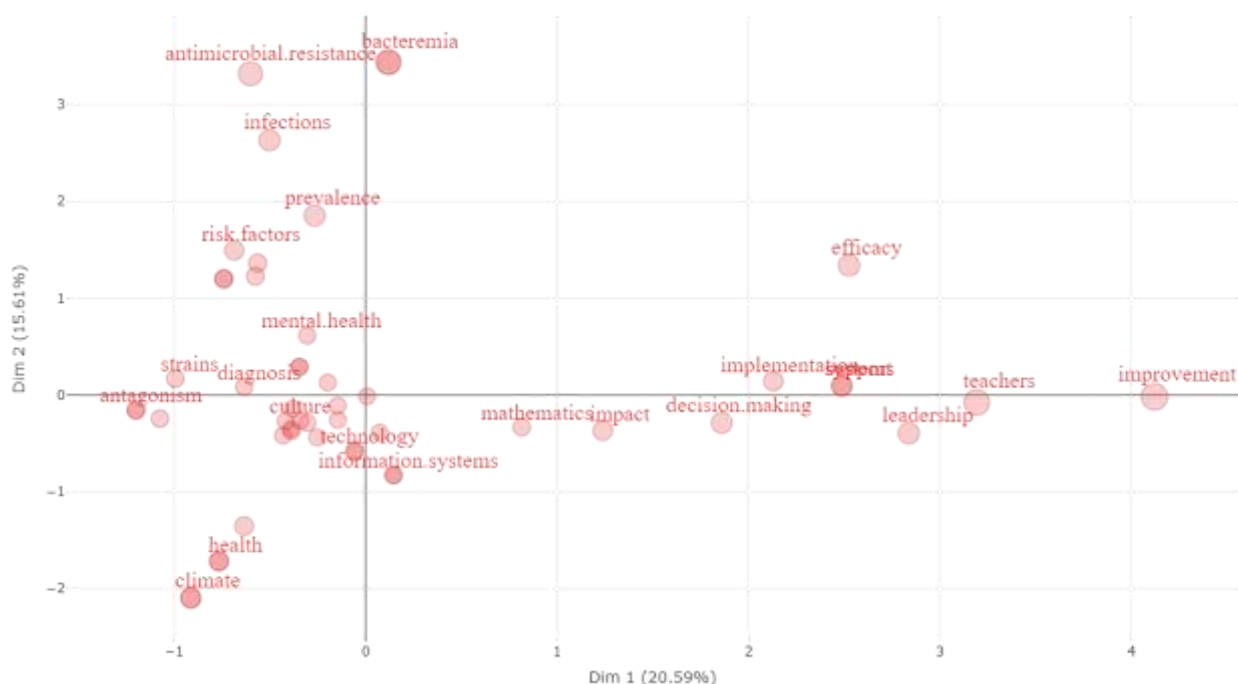

Figure 6: Factorial Analysis (Word Map)

Figure 6 shows the output of a dimensionality reduction technique such as factorial analysis, which reduces the dimensionality of a dataset while retaining the most essential information. Figure 6 depicts the words, and the dimensions (Dimensions 1 – horizontal axis and 2 – vertical axis) represent two new orthogonal variables that capture the variance in the original data. Dims 1 and 2 represent the extent to which each word is positively or negatively associated, respectively. Words with positive values were positively associated with Dim 1 and 2, whereas words with negative values had a negative association.

The word map shows that teachers, improvement, leadership, efficacy, government, and implementation had strong positive associations with both dimensions. In contrast, climate, injuries, health, big data, and frameworks had strong negative associations with both dimensions. Positive and negative associations indicate how strongly each word contributes to the dimensions. These results can clarify which words or concepts are related or distinct in the employed dataset, which can be applied in various fields, such as text analysis, natural language processing, and topic modelling.

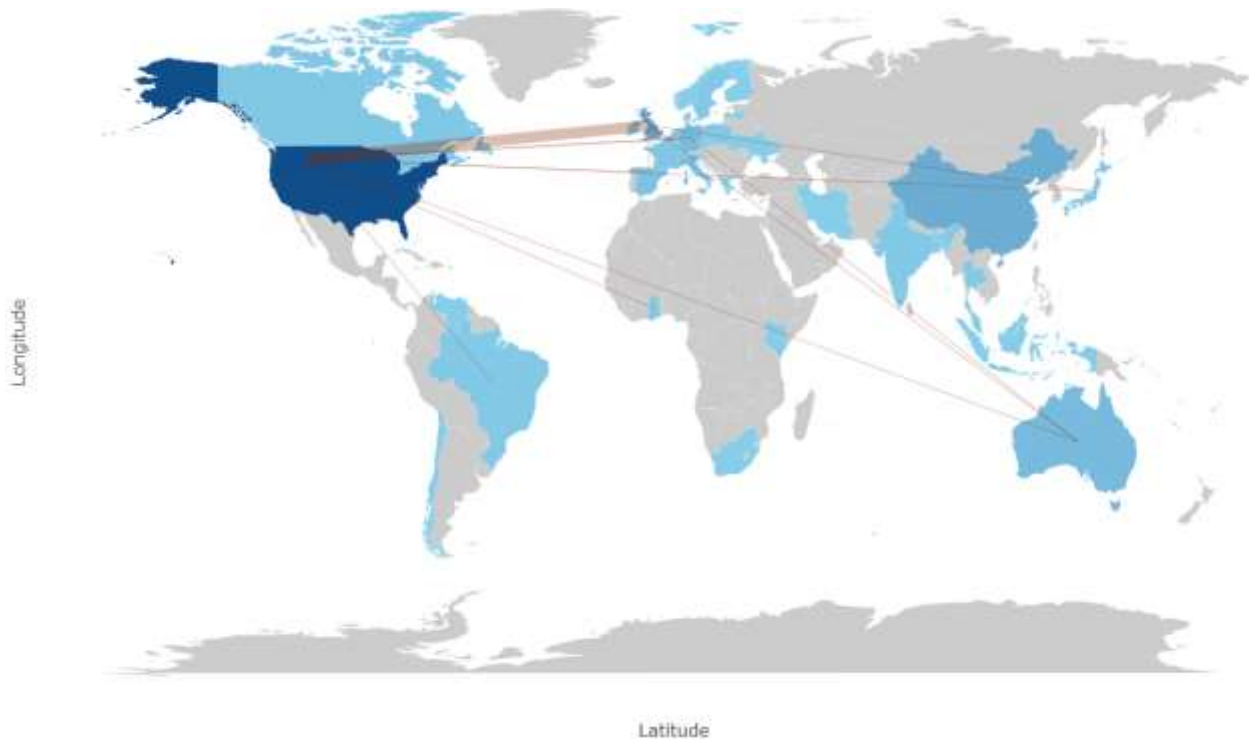

Figure 7: Countries' Collaboration World Map of Data Culture

Figure 7 shows the countries' collaboration in data culture, and the results represent international connections or relationships between various countries, along with the frequency of their connections. Australia had international collaborations with ten countries in data culture, including Belgium, Belize, Germany, Japan, Kenya, Norway, Qatar, Singapore, Sweden, and Venezuela. Australia's collaboration was intercontinental. Further, Belgium collaborated with eleven countries: Belize with Qatar and Venezuela, Brazil with Chile, and the Czech Republic. Canada has four countries, South America and Europe. Denmark worked with Switzerland, France, and Germany in three different countries, Italy in Spain, Japan in four countries, and Kenya in five. The Netherlands has six countries: Poland with two, Qatar with Venezuela, Singapore with three, and Sweden with Norway.

The United Kingdom and the United States of America (USA) have notable connections with a frequency greater than one collaborator. For instance, the United Kingdom had 16 collaborators once, except for Australia, Belgium, France, and Japan, with two frequencies. Likewise, the USA had higher collaborators of twenty-four. The USA had the highest collaboration with the United Kingdom, six times. These results provide insights into the frequency and nature of connections between countries, which can be valuable in understanding international relationships and collaborations.

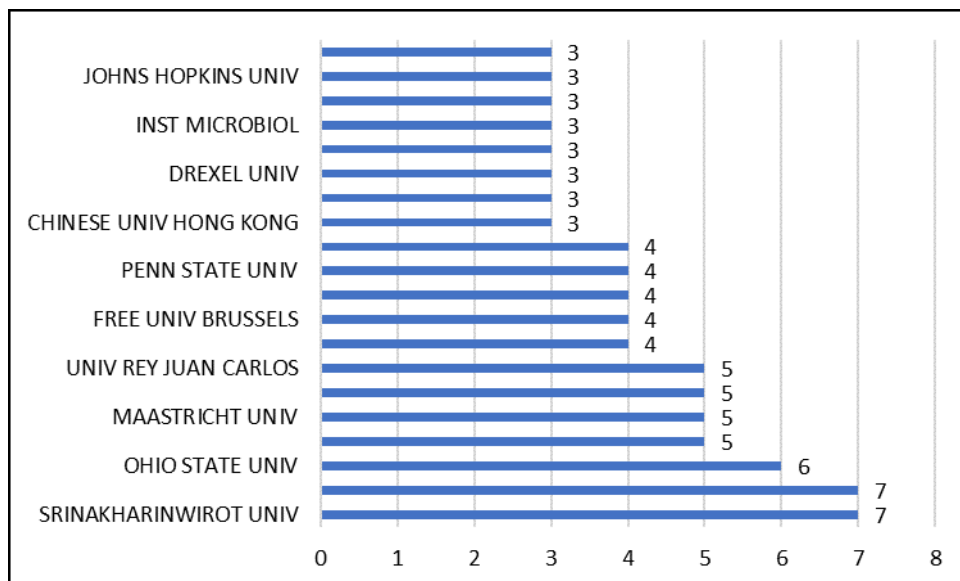

Figure 8. Affiliation of Data Culture Authors

Author's affiliation is one way to examine the visibility and the accessibility of scientific knowledge in the field of data culture. Ohio State University, United States of America and Srinakharinwirot University in Thailand top the list of affiliation with 7 publications each. Other universities followed in turn with 5, 4 and 3 publications. For visibility and the accessibility of scientific knowledge in data culture, there are a lot of gaps as the frequency of publication needs more attention (Figure 8).

Table 1: Corresponding Author's Countries

Country	Articles	SCP	MCP	Freq	MCP_Ratio
USA	28	23	5	0.295	0.179
China	10	9	1	0.105	0.1
United Kingdom	7	6	1	0.074	0.143
Italy	5	5	0	0.053	0
Netherlands	4	2	2	0.042	0.5
Spain	4	2	2	0.042	0.5
Australia	3	2	1	0.032	0.333
Denmark	3	2	1	0.032	0.333
Germany	3	3	0	0.032	0
Belgium	2	2	0	0.021	0
Canada	2	2	0	0.021	0
France	2	1	1	0.021	0.5
Ghana	2	0	2	0.021	1
India	2	2	0	0.021	0
Sweden	2	1	1	0.021	0.5
Switzerland	2	2	0	0.021	0
Thailand	2	2	0	0.021	0
Bangladesh	1	0	1	0.011	1
Finland	1	1	0	0.011	0
Greece	1	1	0	0.011	0
Indonesia	1	1	0	0.011	0
Iran	1	1	0	0.011	0
Kenya	1	0	1	0.011	1
Latvia	1	1	0	0.011	0
Malaysia	1	0	1	0.011	1
Poland	1	1	0	0.011	0
South Africa	1	1	0	0.011	0
Ukraine	1	1	0	0.011	0

Note: SCP: Single Country Publications. MCP: Multiple Country Publications

Table 1 contains information about countries, number of articles published (articles), number of single-authorized publications (SCP), number of multi-authorized publications (MCP), frequency of publications (Freq), and MCP\_Ratio (MCP\_Ratio). The table lists the names of the various countries involved in data culture publications, the number of articles published by researchers from each country, the number of articles in which a single author from that country was involved in the publication, and the number of articles where multiple authors, including at least one author from that country, were included in the publication. The frequency of publications in Table 1 was calculated as the number of articles divided by the total number of articles in the table. This column shows the relative contribution of each country to the total number of articles, while the ratio of multi-authored publications depicts the multi-country publications divided by articles. This indicates how many researchers from a particular country collaborate with researchers from others.

This study shows that the USA has the highest number of articles (28) and a relatively high frequency of publications (0.295). Most of its publications involved multiple authors, with an MCP ratio of 0.179. China has ten articles, with a lower frequency (0.105) than the USA. However, it had a relatively high MCP ratio (0.1), indicating significant collaboration in its publications. With seven articles, the United Kingdom had a moderate frequency (0.074) and an MCP ratio of 0.143, indicating a fair amount of collaboration in its publications.

Italy, the Netherlands, Spain, Australia, and Denmark had lower article counts (ranging from three to five), and their frequencies and MCP ratios varied. Italy has a high SCP count (indicating more single-authored publications), while the Netherlands and Spain have equal numbers of SCP and MCP. Australia and Denmark have similar profiles, with moderate frequencies and MCP ratios. In contrast, Ghana, Bangladesh, Kenya, and Malaysia have lower article counts (1 or 2), but tend to have high MCP ratios, suggesting a strong tendency for collaborative multi-authored publications. Several countries have only one article each with varying SCP and MCP ratios. Some have no multi-authored publications (MCP ratio of 0), whereas others have a balanced mix of single and multi-authored publications.

These findings provide insights into the publication patterns of different countries, highlighting variations in the number of articles, collaboration tendencies, and the balance between single- and multi-author publications. This study revealed that collaboration in multi-authored publications is a common practice, with some countries having a higher propensity for such collaborations.

## CONCLUSIONS

### Theoretical Contribution to Data Culture

Schwartz's Cultural Values Theory significantly enriches our understanding of the research needs related to data culture. This theoretical framework plays a pivotal role in identifying critical areas of inquiry, shedding light on cultural influences, and shaping the research trajectory in this domain. Schwartz's theory has left an indelible mark on the formation of these research needs. Schwartz's theory highlights the profound impact of cultural values on individuals' attitudes, behaviors, and decision-making processes. In doing so, it prompts researchers to acknowledge the pivotal role that cultural values play in an organization's development and its journey toward embracing a data-centric culture. Consequently, it underscores the imperative to investigate how distinct cultural values influence organizational data culture. Moreover, this theory provides a launching pad for cross-cultural analysis. By asserting the existence of universal values with differing priorities across cultures, it encourages researchers to embark on cross-cultural examinations. This avenue of exploration beckons researchers to unravel the intricacies of how data culture varies across diverse cultural landscapes and to ascertain how organizations can align their data practices with the prevailing cultural values in specific contexts.

Schwartz's theory goes beyond mere identification; it prioritizes values. The circular model of values elucidated by this theory equips researchers with the tools to discern which values take precedence within data culture. This prioritization beckons pertinent questions about the values that organizations prioritize concerning data management, decision-making, and innovation. For instance, do some organizations prioritize data security over data-driven innovation due to entrenched cultural values? Moreover, this theory sheds light on the notions of conflict and compatibility. Identifying conflicting and compatible values within the circular structure of this theory raises the need to investigate how these conflicts and compatibilities manifest within the sphere of data culture. Researchers are thus prompted to delve into ethical dilemmas, decision-making trade-offs, and organizational tensions stemming from divergent cultural values related to data, leading to a call for the exploration of cultural clustering within industries or geographic regions and an understanding of how these clusters shape data culture strategies.

Furthermore, this theory extends its influence to the individual level. Its applicability to individual-level behavior encourages researchers to probe how employees with diverse cultural values approach data literacy, data-driven decision-making, and data ethics. This development underscores the significance of researching how cultural values impact individual data-related behaviors and practices. Moreover, Schwartz's Cultural Values Theory promotes interdisciplinary collaboration. It serves as a bridge that encourages collaboration between psychology, sociology, and data science scholars. Such interdisciplinary collaboration promises a more comprehensive understanding of how cultural values intersect with data culture, necessitating research initiatives to foster and facilitate such interdisciplinary partnerships. Lastly, the theory underscores the importance of mixed-methods research. Its emphasis on values as drivers of behavior highlight the need for a mixed-methods approach, combining quantitative analysis with qualitative methods. This approach empowers researchers to delve deeply into the intricate complexities of how cultural influences shape data culture.

Schwartz's Cultural Values Theory is a foundational framework that informs and shapes the research needs identified in this discourse. It emphasizes the imperative of considering cultural values in the study of data culture, promoting cross-cultural awareness, and exploring the intricate interplay between culture and data-related practices. This theoretical foundation enriches the research landscape, providing a profound understanding of how cultural values contribute to the formation and evolution of data culture within organizations.

In today's data-driven world, fostering a robust data culture within organizations is paramount for innovation, efficiency, and informed decision-making. As explored through various studies and research, data culture encompasses a range of dimensions, including data literacy, data-driven decision-making, data collection, quality, sharing, leadership support, governance, performance measurement, continuous learning, transparency, and ethics. This cultural transformation empowers organizations to harness the strategic potential of data, leading to better outcomes and a competitive edge.

The academic research examined in this paper has shed light on the multifaceted aspects of data culture and its impact across different domains. Chatterjee et al. (2021) underscored the influence of data-driven culture on product and process innovation,

emphasizing the pivotal role of leadership support. Liu, Fang, Feng, and Gao (2022) revealed the potential of big data analytics capability in improving green supply chain integration, highlighting the moderating effect of a data-driven decision culture. McCord et al. (2021) emphasized the need for a cultural shift to prioritize data quality in ecological research. Su et al. (2021) proposed innovative methods to measure secondhand smoke exposure among expectant mothers in China, addressing unique cultural challenges.

However, while these studies have contributed significantly to understanding data culture and its implications, there remains a notable gap in the exploration of bibliometric data culture and its influence on scholarly communication within academic and research communities. This study investigates how integrating bibliometric data culture influences scholarly behaviors and practices, publishing trends, citation practices, and the visibility and accessibility of scientific knowledge. To bridge this gap. As demonstrated in the methodology section, the study will employ bibliometric data analysis techniques to examine the growth and trends in data culture publications. It will delve into the affiliations of data culture authors to gauge the visibility of this scientific knowledge. By answering the research questions, the study aims to contribute to the evolving discourse on data culture and its relevance in the scholarly communication landscape.

In conclusion, data culture continues to evolve as organizations recognize the transformative potential of data. The academic research highlighted in this paper showcases its profound impact across diverse fields, from business and supply chain management to ecological studies and public health. Nevertheless, there is still much to explore, particularly in the context of bibliometric data culture. By delving into this uncharted territory, researchers can further enrich our understanding of how data culture influences scholarly communication and knowledge dissemination, ultimately advancing the practice of data-driven decision-making in academia, organizations, and institutions.

### **Managerial Contribution to Data Culture**

This study highlights the importance of cultural values in data managers scholarly communication. Researchers can benefit from recognizing that cultural nuances play a role in the dissemination and reception of their work. They can adapt their communication strategies to better connect with diverse audiences, especially in an increasingly globalized academic landscape. They can help data managers to understand the influence of cultural values on scholarly communication, which can encourage international collaboration. Academics from different cultural backgrounds can use this knowledge to bridge communication gaps, effectively collaborate, and ensure that their research reaches a broad audience.

It also considers cultural factors in the publication trends of the data managers. Academics can use this knowledge to strategically plan their publications by considering cultural variations in citation practices and trends. The results of this study can help researchers to increase the visibility and impact of their work. On the other hand, this study suggests how organizations and institutional data managers learn from the concept of "data culture" and its evolving nature. They recognize that fostering a data culture is not a one-time effort but an ongoing process. Organizations should invest in continuous data literacy training, promote data-driven decision-making, and create an environment that values data as a strategic asset. This research emphasizes the significance of cultural values for multinational organizations and institutional managers on how to work with diverse teams. This study suggests that organizations should promote cross-cultural collaboration and sensitivity, especially in data-related projects. This collaboration can lead to more effective teamwork and better utilization of data resources.

This study underscores the importance of data-driven decision making for data managers. Organizations should encourage a culture in which data informs decisions at all levels. This development can result in more informed and effective decision-making processes, ultimately benefiting the organization's performance and competitiveness, and suggests that organizations recognize that cultural values can influence how data are perceived and used within the organization. Tailoring data-related practices and policies to align with prevailing cultural values can lead to greater acceptance and success in implementing data-driven initiatives. This study may help managers in institutions engaged in research and education understand the impact of cultural values on scholarly communication. They can take steps to ensure that research findings are disseminated effectively, considering the cultural factors that influence citation practices and trends.

Research on bibliometric data culture offers practical insights that extend beyond academic and real-life applications. This study highlights the importance of cultural awareness in scholarly and organizational data practices. By acknowledging and adapting to cultural values, academics and organizations can enhance their effectiveness, collaboration, and impact on the data-driven world, ultimately advancing the practice of data-driven decision-making.

### **Limitations and Future Study**

While the methodology used in bibliometric analysis is rigorous, it is limited to analyzing published academic papers. This study may exclude valuable insights from gray literature, industry reports, and non-academic sources, which could provide a more comprehensive view of data culture in practice. Combining quantitative bibliometric analysis with qualitative research methods, such as interviews and surveys, can provide a deeper understanding of the human and organizational aspects of data culture. This mixed-methods approach would offer insights into the motivations, challenges, and success factors in cultivating data culture.

## ACKNOWLEDGMENT

This work was supported by the Foundation for Economic Education (Liikesivistysrahasto), Finland [grant numbers: 16–9388, 18–10407] and JAMK University of Applied Sciences, Business School, Jyväskylä, Finland.

## REFERENCES

- Alsaad, A. (2018). The individualistic view of culture and the nascent entrepreneurship: An examination of Schwartz's cultural values. *Journal of Developmental Entrepreneurship*, 23(4), 1850026. <https://doi.org/10.1142/S1084946718500266>
- Aria, M., & Cuccurullo, C. (2017). Bibliometrix: An R-tool for comprehensive science mapping analysis. *Journal of Informetrics*, 11(4), 959–975. <https://doi.org/10.1016/j.joi.2017.08.007>
- Bagchi, K., & Kirs, P. (2009). The impact of Schwartz's cultural value types on ICT use: A multi-national individual-level analysis. In *Proceedings of the International Conference on Information Systems*, 205. ICIS, Phoenix, Arizona, USA, December 15–18.
- Chatterjee, S., Chaudhuri, R., & Vrontis, D. (2021). Does data-driven culture impact innovation and performance of a firm? An empirical examination. *Annals of Operations Research*, 1-26. <https://doi.org/10.1007/s10479-021-04277-z>
- Kolešnik, K. (2013). The role of culture in accounting in the light of Hofstede's, Gray's and Schwartz's cultural dimensions theories: A literature review. *E-Finanse: Financial Internet Quarterly*, 9(3), 33–41.
- Liu, Y., Fang, W., Feng, T., & Gao, N. (2022). Bolstering green supply chain integration via big data analytics capability: The moderating role of data-driven decision culture. *Industrial Management & Data Systems*, 122(11), 2558–2582. <https://doi.org/10.1108/IMDS-02-2021-0124>
- McCord, S. E., Webb, N. P., Van Zee, J. W., Burnett, S. H., Christensen, E. M., Courtright, E. M., & Tweedie, C. (2021). Provoking a cultural shift in data quality. *BioScience*, 71(6), 647–657. <https://doi.org/10.1093/biosci/biab031>
- Olaleye, S. A. (2020). Visualizing cultural emotional intelligence literature: A bibliometric review 2001–2020. *Intercultural Competence at Work*, 19 November 2020, Seinäjoki, Finland.
- Olaleye, S. A., & Adusei, A. G. (2022a). Data economy through productization: A conceptual paper. In *From Globalization to Regionalization in a Time of Economic, Socio-Political, Competitive, and Technological Uncertainties: Current Issues and Future Expectations. Twenty Ninth World Business Congress*, June 12–16, 2022, JAMK University of Applied Sciences Jyväskylä, Finland. International Management Development Association.
- Olaleye, S. A., Mogaji, E., Agbo, F. J., Ukpabi, D., & Adusei, A. G. (2022b). The composition of data economy: A bibliometric approach and TCCM framework of conceptual, intellectual and social structure. *Information Discovery and Delivery*, 51(2), 223–240. <https://doi.org/10.1108/IDD-03-2021-0043>
- Olaleye, S. A. (2023). Bibliometric Viewpoints of Wired Campus Through Higher Institution Blogging. In *Transformation of Higher Education Through Institutional Online Spaces* (pp. 160–178). IGI Global.
- Sagiv, L., & Schwartz, S. H. (2022). Personal values across cultures. *Annual Review of Psychology*, 73, 517–546. <https://doi.org/10.1146/annurev-psych-010420-084053>
- Schwartz, S. H. (1999). A theory of cultural values and some implications for work. *Applied Psychology*, 48(1), 23–47.
- Schwartz, S. H. (2012). An overview of the Schwartz theory of basic values. *Online Readings in Psychology and Culture*, 2(1). <https://doi.org/10.9707/2307-0919.1116>
- Su, Z., McDonnell, D., Abbas, J., Shi, L., Cai, Y., & Yang, L. (2021). Secondhand smoke exposure of expectant mothers in China: Factoring in the role of culture in data collection. *JMIR Cancer*, 7(4), e24984. <https://doi.org/10.2196/24984>
- Tekeş, B., Üzümcüoğlu, Y., Hoe, C., & Özkan, T. (2019). The relationship between Hofstede's cultural dimensions, Schwartz's cultural values, and obesity. *Psychological Reports*, 122(3), 968–987.
- Van Eck, N. J., & Waltman, L. (2017). Citation-based clustering of publications using CitNetExplorer and VOSviewer. *Scientometrics*, 111, 1053–1070. <https://doi.org/10.1007/s11192-017-2300-7>
- Vauclair, C. M., Hanke, K., Fischer, R., & Fontaine, J. (2011). The structure of human values at the culture level: A meta-analytical replication of Schwartz's value orientations using the Rokeach Value Survey. *Journal of Cross-Cultural Psychology*, 42(2), 186–205. <https://doi.org/10.1177/0022022110393906>

## Exploring Factors Influencing E-Learning Acceptance: An Integration of Transactional Distance Theory and Technology Acceptance Model

Kun Tian <sup>1,\*</sup>  
Jing Wu <sup>2</sup>

\*Corresponding author

<sup>1</sup> Associate Professor, Wuhan Business University, Wuhan, China, tiank@wbu.edu.cn

<sup>2</sup> Lecturer, Wuhan Business University, Wuhan, China, 329023745@qq.com

### ABSTRACT

This study endeavors to scrutinize and ascertain the factors that impact students' acceptance and utilization of E-learning platforms. Combining the Transactional Distance Theory (TDT) and the Technology Acceptance Model (TAM), the methodology employed in this research was quantitative, gathering data from 255 participants engaged in higher education via E-learning platforms and data were analyzed by SPSSAU. The proposed model demonstrates five key determinants that influence students' acceptance of E-learning. The empirical evidence implies that the structure, dialogue, and learners' autonomy significantly influence students' intention to utilize E-learning platforms. Furthermore, the two constructs of TAM - perceived ease of use and perceived usefulness - correlate positively with the same. The study's results thus substantially validate the conjunct integration of TDT and TAM relating to E-learning utilization intent, providing crucial insights for key stakeholders in higher education institutions to strategize, evaluate, and implement E-learning systems more effectively.

*Keywords:* TDT, structure, dialogue, learners, autonomy, TAM

### INTRODUCTION

In tandem with the rapid progression of information technologies, there has been a substantial upsurge in internet-based learning activities. E-learning, noted for its flexibility and non-dependence on temporal and spatial constraints (Cheng, 2012), has emerged as a viable extension to conventional classroom-based instruction. Nonetheless, it is not devoid of limitations such as diminished social presence affecting learner motivation and outcomes (Tang & Hew, 2019). Despite these constraints, E-learning continues to be recognized as a potent substitute to traditional pedagogy (Liu et al., 2010).

The Technology Acceptance Model (TAM), a seminal framework for examining technology acceptance and rejection (Davis, 1986; 1989), has been extensively deployed in academic environments (Al-Emran et al., 2018). Supporting the model's robustness are numerous studies that have consequently led to TAM evolving into a fundamental theory to understand predictors of user intention towards technology usage (Granić & Marangunić, 2019). However, empirical studies focusing on Chinese learners' technology acceptance remain sparse, particularly those investigating drivers of technology adoption for learning (Hao et al., 2017; Huang et al., 2019; Teo et al., 2019; Yang et al., 2017; Zhou, 2016).

In response to the 2020 directives of the Ministry of Education of the People's Republic of China, online pedagogy has been fervently endorsed for higher education, leading to the creation and utilization of numerous E-learning platforms. Yet, meritorious online learning is not solely contingent on provisioning an E-learning system, but necessitates the consideration of varied dimensions including system architecture, course development, and user dynamics (Persico et al., 2014). Consequently, investigating learner-related factors becomes indispensable in enhancing the efficacy of remote education, specifically during unforeseen exigencies.

Following this perspective, the present study, employing TAM as a theoretical framework, endeavors to discern potential determinants influencing students' acceptance of an E-learning platform at a Chinese university. The objective is multifold: to augment the original TAM model, identify precursors to technology use from the user's vantage point, guide future implementations of online education, and contribute to the design improvement of online education platforms, enhancing overall learner acceptance.

### RESEARCH QUESTIONS

E-learning leverages untapped educational opportunities for students and provides viable solutions for institutions facing infrastructure-related problems due to increasing enrollments. Yet, the acceptance and efficiency of this instructional method have been met with apprehension, illuminated by negative feedback from educators and students, particularly due to the physical separation and altered learning experience. However, the escalating body of evidence countering these sentiments and the burgeoning participation and interest necessitates further examination. This study focuses specifically on the structure of E-learning platforms and its relation to aspects such as student autonomy and dialogue (student-to-student and student-to-



instructor interactions), aiming to enhance the effectiveness of E-learning experiences. The major research question that is anticipated to be answered is:

How could we improve students' acceptance towards E-learning course?

To be able to answer this question, it is required to examine numerous sub-questions which have been stated as follow:

Q1: How does the structure of a E-learning course affect students' acceptance?

Q2: How does the dialogue of a E-learning course affect students' acceptance?

Q3: How does the learners' autonomy affect their acceptance towards the E-learning courses?

## THEORETICAL BASIS AND HYPOTHESIS DEVELOPMENT

### E-Learning Course

The landscape of modern education has witnessed a significant shift with the advent of E-learning course. This digital derivative of education, also known as electronic learning, has caught the attention of various researchers and scholars over recent years. According to Al-Fraihat et al. (2020), E-learning is the use of electronic technologies to create a flexible, learner-centric education model that is accessible from anywhere, anytime. E-learning is commonly structured around two main axes: synchronous and asynchronous learning. Synchronous learning, as defined by Dabbagh (2007), involves real-time, interactive teaching methods, such as live lectures, web-based discussions, and instant feedback mechanisms. On the other hand, asynchronous learning, according to Hrastinski (2008), is centered around flexibility and self-paced learning, employing methods such as pre-recorded lectures, emails, and other online resources that learners can access as per their convenience.

Research on factors affecting E-learning efficacy has pinpointed crucial elements such as course structure, learners' autonomy, dialogue, and technology. A study by Huang et al. (2015) emphasizes that a well-structured course with clearly defined learning objectives, instructions, and appropriate resources is crucial to enhancing learning outcomes. Furthermore, learner autonomy in E-learning has proven to be a significant factor in learner's participation and motivation (Moore, 2012). The role of dialogue within E-learning courses has also been highlighted, influencing the overall learning experience positively. Learner-learner and learner-instructor interactions promote a shared sense of community and facilitate feedback exchange (Garrison, Anderson & Archer, 2001). Lastly, the role of reliable, user-friendly technology is undeniable in providing a holistic and seamless e-learning experience (Sun, Tsai, Finger, Chen & Yeh, 2008). E-learning, jeopardizing traditional brick-and-mortar educational models, pairs technology with education, presenting a unique blend of accessibility and quality. Course structure, autonomy, dialogue, and technology have been identified as critical determinants of E-learning efficacy, underpinning its acceptance among learners and educators alike.

### Technology Acceptance Model

The Technology Acceptance Model (TAM), as postulated by Davis (1989), suggests that the aspects of perceived usefulness and perceived ease of use shape user attitudes towards technology (see Figure 1). These attitudes, in turn, influence the behavioral intention to either utilize or reject technology. TAM represents a theoretical model that provides an insightful framework for understanding attitudes toward novel technology applications (Charness & Boot, 2016). Critical determinants of the acceptance or rejection of new technology, according to the model, are perceived usefulness and ease of use, although other variable factors can also exert influence. Numerous studies have utilized TAM as the underlying framework, exploring attitudes towards emergent technologies. For instance, investigated student attitudes towards E-learning technology. Their findings indicated that student acceptance of this technology was significantly influenced by factors such as perceived usefulness, efficiency, and effectiveness (Masrom, 2007).

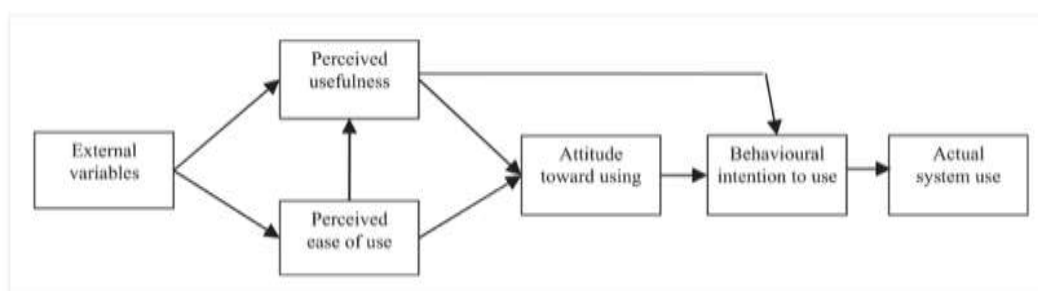

Figure 1. Technology acceptance model (Davis, 1989).

### Transactional Distance Theory

Dr. Michael Moore's Transactional Distance Theory (TDT) offers a pedagogical foundation for distance education. TDT emphasizes that "distance education transcends geographical separation to revolve chiefly around pedagogical considerations" (Moore, 1993). The theory proposes that geographical separation induces a "transactional distance", a cognitive and communication gap, potentially causing misunderstanding between teachers and students. Moore (1993) avers that transactional distance is influenced by three constituents: structure, dialogue, and learner autonomy. Structure signifies the rigidity or flexibility of a course concerning its objectives, activities, assessments, planned interactions, and adaptiveness to individual learners' needs. Dialogue encompasses purposeful interactions that facilitate the learning procedure. Learner

autonomy alludes to the learners' capability of self-directed learning control and management. The theory posits that these three elements interact to determine the transactional distance. An increased dialogue coupled with a decreased structure tends to reduce transactional distance. However, a scenario of restricted dialogue and rigid structure engenders a larger transactional distance. In this case, learners must demonstrate increased responsibility in their learning journey for favourable outcomes.

### **Hypothesis Development**

The hypothesis development of this study was constructed based on the combination of the different aspects of the theories mentioned above.

*H1: Structure has positive impact on the Perceived Usefulness of an E-learning Platform.*

*H2: Structure has positive impact on the Perceived Ease of Use of an E-learning Platform.*

*H3: Dialogue has positive impact on the Perceived Usefulness of an E-learning Platform.*

*H4: Dialogue has positive impact on the Perceived Ease of Use of an E-learning Platform.*

*H5: Learners' Autonomy has positive impact on the Perceived Usefulness of an E-learning Platform.*

*H6: Learners' Autonomy has positive impact on the Perceived Ease of Use of an E-learning Platform.*

*H7: Perceived Ease of Use has a positive impact on the Perceived Usefulness of an E-learning Platform.*

*H8: Perceived Ease of Use has a positive impact on the Intention to Use an E-learning Platform.*

*H9: Perceived Usefulness has a positive impact the Intention to Use an E-learning Platform.*

## **LITERATURE REVIEW**

### **Structure**

Moore (1973) defined 'structure' as the capability of a learning experience to adapt to each student's needs. Moore (1997) detailed it a bit further by mentioning that structure relates to how flexible a program's methods, goals, and evaluation techniques can be, as well as to what extent a program can meet individual students' needs. In simpler terms, the more a learning environment can personalize a student's experience and offer flexible ways to learn, the more the student tends to feel part of the learning process (Moore, 1997). Environments that are too rigid can feel restrictive to students (Lee & Rha, 2009). Moore posits that the pedagogical constructs of structure and dialogue hold paramount importance in alleviating students' perception of transactional distance within online education courses (Garrison, 2000; Shannon, 2002; Falloon, 2011; Moore, 2012). Structure signifies the configuration of the course, encompassing objectives, pedagogical strategies, instructional content, materials, and evaluation methods (Garrison, 2000; Moore, 2012; Huang et al., 2015). The structure of a course can oscillate between rigidity and flexibility, contingent upon the content, learner interactions, and learner necessities (Huang et al., 2015; Moore, 2012; Shannon, 2002). A more accommodating structure is necessary in pursuit of diversity and individualization that optimally supports each learner (Huang et al., 2015). In highly formalized learning environments, an educator's assessment of learning objectives is made from the beginning of the learning process. Hence, the following hypotheses are proposed:

*H1: Structure has positive impact on the Perceived Usefulness of an E-learning Platform.*

*H2: Structure has positive impact on the Perceived Ease of Use of an E-learning Platform.*

### **Dialogue**

Dialogue in this research involves communication and collaboration between students and instructors to enhance learner understanding and engagement. Besides structure, Moore's theory accentuates the role of dialogue, referring to potent, constructive interpersonal exchanges that aid the learner in consolidating their comprehension of the educational content (Gorsky and Caspi, 2005; Moore, 2012). The concept of dialogue is not fixed but flexible, especially with the advent and continual expansion of online communication tools for teachers and students. It is crucial to ensure these interactive opportunities bolster student understanding (Garrison, 2000; Gorsky and Caspi, 2005; Moore, 2012). The degree of student-teacher interaction inherently dictates the level of learner autonomy (Garrison, 2000). Ultimately, efficacious dialogue inhabits the learning spaces amidst conversations between learners, and those shared between students and teachers (Gorsky and Caspi, 2005; Moore, 2012). Further, several studies have looked into different aspects of dialogue, such as preparation of learners and usage of digital tools for communication (Falloon, 2011). Other researchers like Mathieson (2012) focused on the role of dialogue in online sessions, showing the positive impact of audio-visual feedback through digital tools. Furthermore, Moore (2007) evaluated the impact of dialogue and structure on autonomous learners' experiences. Lastly, several researchers highlighted the critical role teachers play in fostering effective communication and interaction between learners. Based on these studies, the hypotheses are proposed:

*H3: Dialogue has positive impact on the Perceived Usefulness of an E-learning Platform.*

*H4: Dialogue has positive impact on the Perceived Ease of Use of an E-learning Platform.*

### **Learners' Autonomy**

Learners' autonomy refers to a student's independent motivation to learn. It centralizes the student's needs and expectations, a concept particularly vital in online education, which offers the flexibility of choice and fosters independent learning (Massimo, 2014). Learners' autonomy is intrinsically linked to various aspects of the learning process. Madjar et al. (2013) point out that autonomy-supportive environments can bolster online learning acceptability among students, ensuing in enhanced academic achievement. Hence, the need for autonomy in online spaces to kindle student growth and improve university performance.

Researchers advocate that an autonomy-driven approach boosts outcomes regarding objectives and directs teaching methodologies towards goal attainment. It emphasizes designing learning environments with a focus on emotional aspects. Moore further articulates that the interplay between structure, dialogue, and transactional distance is mediated by the student's ability to manifest learning autonomy (Garrison, 2000; Moore, 2012; Huang et al., 2015). Garrison (2000, p.8) suggests, "The greater the transactional distance, the greater responsibility is placed on the learner." This requires instructors to consider learners' capability to regulate their learning, determine if the current format aligns with the students' needs, and make significant modifications to encourage student learning (Garrison, 2000; Shannon, 2002; Moore, 2012). While one extreme of the spectrum might find the student piloting their learning, the opposite end may see the teacher exercising full control over content delivery (Garrison, 2000; Moore, 2012). The Transactional Distance Theory influenced our pedagogical approach, prompting the adoption of novel strategies to balance the imposed distance constraints. Based on previous research, the following hypotheses are proposed:

*H5: Learners' Autonomy has positive impact on the Perceived Usefulness of an E-learning Platform.*

*H6: Learners' Autonomy has positive impact on the Perceived Ease of Use of an E-learning Platform.*

### Perceived Usefulness and Perceived Ease of Use

The influences of Perceived Usefulness and Perceived Ease of Use are potentially shaped by several external factors (Almaiah & Alismaiel, 2018; Venkatesh & Bala, 2008). A spectrum of probable motivating constituents impacting learners' technology acceptance has been evaluated in education, encompassing Computer Self-Efficacy (Al-Azawei et al., 2017; Cakır & Solak, 2015; Cheung & Vogel, 2013; Yeou, 2016), Learner Experience (Liu et al., 2010; Ros et al., 2015), Learning Styles (Al-Azawei et al., 2017), Technical Support (Cheung & Vogel, 2013; Sánchez & Hueros, 2010), Perceived Convenience (Chang et al., 2012), Subjective Norm (Song et al., 2017), and cultural elements (Sang et al., 2010).

Existing literature corroborates that both Perceived Usefulness and Perceived Ease of Use exert a positive influence on the acceptance of technologically-inclined learning (Granić & Marangunić, 2019; Persico et al., 2014). For instance, Al-Azawei et al. (2017), in their examination of learner perceptions towards a blended e-learning system, inferred that Perceived Usefulness and Perceived Ease of Use were indicative of the Intention to Use, consequently boosting learner satisfaction. Analogously, these two factors have been determined to exist as precedent influences on college students' adoption tendencies of English mobile learning, with Perceived Usefulness showing a long-term positive impact on Intention to Use (Chang et al., 2012). A noteworthy connectivity between Perceived Ease of Use and Perceived Usefulness has also been unraveled (Nagy, 2018; Song et al., 2017). For example, Chow et al. (2012) who analyzed medical students' Intention to Use virtual reality technology, identified Perceived Ease of Use as an influential determinant of Perceived Usefulness and behavioral intention. Similarly, Yeou (2016) discovered a direct influence of Perceived Ease of Use on the Perceived Usefulness of Moodle among university students. In the wake of these revelations, the ensuing hypotheses are proposed:

*H7: Perceived Ease of Use has a positive impact on the Perceived Usefulness of an E-learning Platform.*

*H8: Perceived Ease of Use has a positive impact on the Intention to Use an E-learning Platform.*

*H9: Perceived Usefulness has a positive impact on the Intention to Use an E-learning Platform.*

In light of the aforementioned theoretical variables and hypothesized relationships, we construct a research model to investigate the interrelationships among factors potentially influencing students' intention to utilize an E-learning Platform. The proposed model, explicated in Figure 2, forms the basis of the exploration.

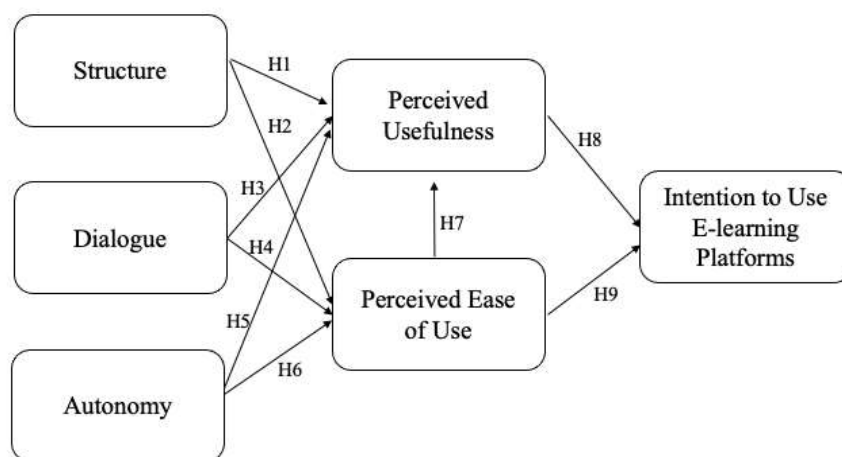

Figure 2. Research model and Hypotheses

## DATA COLLECTION AND ANALYSIS

### Scale Design

This research employed a survey method via a well-structured questionnaire to test the study's hypothesis, drawing from two relevant theories. The survey was divided into two sections - one focused on demographics like age, gender, educational level, and the other concentrated on 24 items adapted from past studies. They cover Structure, 4 items, adapted from Akaslan and Law(2011), Dialogue, 4 items, adapted from Bolliger and Inan (2012), Learners' autonomy, 4 items, adapted from Barnard (2009) and Pintrich et al., (1991), Perceived ease of use, 4 items, Perceived usefulness, 4 items, and Intention to use, 4 items, adapted from Pekrun et al., (2005).

Before data collection began, the research obtained necessary permissions from Wuhan Business University. It targeted undergraduate E-learning users. Participants completed the survey in Chinese after their E-learning course. Students who received the online survey were asked to provide their details and evaluate their E-learning platform experiences. A preliminary survey was conducted on 50 E-learning students from Wuhan Business University. The statistical software SPSSAU was used to analyse and cleanse the data extracted from this survey, ensuring its accuracy and completeness. The reliability and validity of the questionnaire were tested using methods like Cronbach's Alpha coefficient and split-half reliability. The validity test checked whether the study objectives were accurately reflected in the questionnaire's variables. Based on analysis and test results, the questionnaire was refined for a more accurate reflection of the research aim. This robust process led to the development of an official survey questionnaire.

### Data Collection

The questionnaire is divided into two parts. The first part is of basic personal information, and the second part is the factors affecting students intention of using E-learning platforms. To ensure the rationality and validity of the questionnaire, the questionnaire is distributed in pre-survey stage and formal investigation stage. At the pre-survey, 50 questionnaires were distributed, and the data were used to modify the questionnaire. The collected data are analyzed by SPSSAU for the reliability and validity of the questionnaire. According to the corresponding feedback, the content and structure of the questionnaire are enriched and improved to ensure the scientific and validity of the final questionnaire. During the formal survey period, 300 questionnaires were distributed and total of 255 valid questionnaires were obtained after eliminating the invalid questionnaires. Regarding the respondent's demographic details: 79 (31%) were males, and 176 (69%) were females. 114 (50.6%) were in the age range of 18 to 20 years old, 89 (34.9%) were in the age range of 21 to 22 years old, and 52 (14.5%) were in the age range of 23 to 24 years old. Regarding level of study: 69 (26.9%) were first-year college students, 77 (30.2%) were from the second year, 60(23.4%) were from the third year, and 49 (19.5%) were from the fourth year.

### Test of Reliability and Validity

The reliability and validity test results of the questionnaire on factors influencing E-Learning acceptance are shown in Table 1. AVE and CR were used for convergent validity analysis; usually an AVE greater than 0.5 and a CR greater than 0.7 indicated high convergent validity. Composite AVE ranging from 0.628 to 0.730 means the validity of the analysis is adequate. CR indices of measurement items in this study are higher than 0.7, suggesting good internal consistency and reliable analysis results. Cronbach's  $\alpha$  stands for the extent of the close relationship of items in a group, and is used to measure the scale reliability of the items. When Cronbach's  $\alpha$  is higher than 0.8, it implies that the items have a relatively high internal consistency.

Table 1: Test of reliability

Construct	AVE	CR	Cronbach's $\alpha$
Structure	0.662	0.896	0.882
Dialogue	0.633	0.794	0.819
Autonomy	0.712	0.890	0.879
PU	0.629	0.806	0.824
PEoU	0.603	0.829	0.818
IU	0.670	0.868	0.860

The validity analysis of all the measures shown in Table 2 suggests that the KMO value of the overall scale was greater than 0.8, and the significance of Bartlett's spherical test value was less than 0.001, indicating that the study data had good validity and reached a significant level.

Table 2: Test of KMO and Bartlett

	KMO	0.849
	Chi-square	361.345
Bartlett's Test	<i>df</i>	21
	<i>p</i>	0.000

## Test of Model Fitness

Table 3: Model fitness

Indicator	$\chi^2/df$	GFI	RMSEA	AGFI	CFI	NFI	NNFI
Std. value	<3	>0.9	<0.10	>0.9	>0.9	>0.9	>0.9
Value	2.037	0.903	0.080	0.942	0.907	0.913	0.911

The model fitness value in Table 3,  $\chi^2/df=2.037 < 3$ , GFI= 0.903, RMSEA=0.080, AGFI=0.942, CFI=0.907, NFI=0.913, NNFI=0.911, implying that the model is statistically significant and worth being further analyzed.

Table 4: Path coefficients

X	→	Y	Unstd. Coef	SE	z (CR)	p	Std. Coef	Conclusion
S	→	PU	0.306	0.077	3.966	0.000	0.277	Support
D	→	PU	0.432	0.063	2.784	0.027	0.498	Support
A	→	PU	0.145	0.057	2.535	0.011	0.174	Support
S	→	PEoU	0.455	0.096	4.827	0.000	0.397	Support
D	→	PEoU	0.283	0.091	3.116	0.002	0.259	Support
A	→	PEoU	0.188	0.074	2.514	0.012	0.178	Support
PEoU	→	PU	0.420	0.059	6.130	0.000	0.455	Support
PU	→	IU	0.377	0.092	4.063	0.000	0.335	Support
PEoU	→	IU	0.525	0.086	5.127	0.000	0.511	Support

Table 4 shows the path coefficients and the structural relationships of the model, which include the unstandardized path coefficient (Unstd. Coef.), standard error (SE), z values (CR), the corresponding significance of the effects (p values), standardized path coefficient (Std. coef) and conclusions of support for each hypothesis.

Specifically, Structure has a standardized path coefficient value of 0.277>0 for PU influence and this path shows a significance at 0.01 level ( $z=3.966$ ,  $p=0.000<0.01$ ), thus indicating that Structure has significant positive influence relationship on PU; Dialogue has a standardized path coefficient value of 0.498>0 for PU influence and this path shows a significance at 0.05 level ( $z=2.784$ ,  $p=0.027<0.05$ ), thus indicating that Dialogue has significant positive influence relationship on PU; Autonomy has a standardized path coefficient value of 0.174>0 for PU influence and this path shows a significance at 0.05 level ( $z=2.535$ ,  $p=0.011<0.05$ ), thus indicating that Autonomy has significant positive influence relationship on PU. Structure has a standardized path coefficient value of 0.397>0 for PEoU influence and this path shows a significance at 0.01 level ( $z=4.827$ ,  $p=0.000<0.01$ ), thus indicating that Structure has significant positive influence relationship on PEoU; Dialogue has a standardized path coefficient value of 0.259>0 for PEoU influence and this path shows a significance at 0.01 level ( $z=3.116$ ,  $p=0.002<0.01$ ), thus indicating that Dialogue has significant positive influence relationship on PEoU; Autonomy has a standardized path coefficient value of 0.178>0 for PEoU influence and this path shows a significance at 0.05 level ( $z=2.514$ ,  $p=0.012<0.05$ ), thus indicating that Autonomy has significant positive influence relationship on PEoU. As a result, hypotheses H1, H2, H3, H4, H5, and H6 were supported.

PEoU has a standardized path coefficient value of 0.455>0 for PU influence and this path shows a significance at 0.01 level ( $z=6.130$ ,  $p=0.000<0.01$ ), thus indicating that PEoU has significant positive influence relationship on PU; PU has a standardized path coefficient value of 0.335>0 for IU influence and this path shows a significance at 0.01 level ( $z=4.063$ ,  $p=0.000<0.01$ ), thus indicating that PU has significant positive influence relationship on IU; PEoU has a standardized path coefficient value of 0.511>0 for IU influence and this path shows a significance at 0.01 level ( $z=5.127$ ,  $p=0.000<0.01$ ), thus indicating that PEoU has significant positive influence relationship on IU; As a result, hypotheses H7, H8 and H9 were supported.

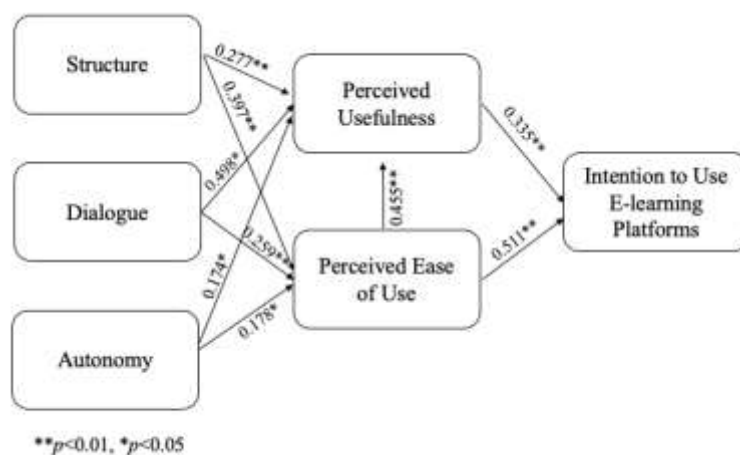

Figure 3. Test result of research model

Based on the test result of research model in Figure 3, it is apparent that all the hypotheses are verified. In the context of E-learning, structure, dialogue and learners' autonomy have positive influence on perceived usefulness and perceived ease of use; while perceived ease of use has positive influence on perceived usefulness; perceived usefulness and perceived ease of use have positive influence on learners' intention to use E-learning platforms.

### DISCUSSION

Reflecting on our research question – how we could improve students' acceptance towards E-learning courses – it seems the answer resides in a multifaceted approach. Our manifold analysis illustrates that structure, dialogue, learners' autonomy, and perceivable benefits, particularly with regard to usefulness and accessibility of course material, all play compelling roles in fostering students' acceptance of E-learning.

The influence of structure on E-learning platforms was made apparent in the study. A well-structured course that is robust yet flexible can guide students through their learning with ease, thereby improving acceptance. This result aligns with our first sub-question, “How does the structure of an E-learning course affect students' acceptance?”.

Subsequently, dialogue was also found to have a critical effect on E-learning acceptance. Facilitating open and meaningful interaction between teachers and students could foster understanding and lessen the cognitive gap that might occur in distance learning. This directly addresses our second sub-question, “How does the dialogue of an E-learning course affect students' acceptance?”.

Additionally, the study found that the element of learners' autonomy has a significant impact on their acceptance of E-learning. Autonomy empowers students to have control over their learning process, and a platform that supports this not only encourages academic growth but also teaches responsibility and self-discipline, which directly resonates with our third sub-question, “How does the learners' autonomy affect their acceptance towards the E-learning courses?”.

Lastly, the results indicated that the constructs of TAM, namely, perceived usefulness and ease of use, are crucial to students' engagement with E-learning platforms. Clearly articulated advantages and a user-friendly interface can bolster students' inclination to accept and engage with E-learning more readily.

### IMPLICATION

Theoretically, this research blends Transactional Distance Theory (TDT) and the Technology Acceptance Model (TAM) to offer a unique perspective on E-learning acceptance. While the work cautiously highlights the potential significance of structure, dialogue, and learner's autonomy (from TDT) as well as perceived usefulness and ease of use (from TAM) in shaping E-learning acceptance, it also acknowledges the exploratory nature of the integrated model. This nascent fusion calls for a more thorough academic exploration to ascertain its universal applicability across different online learning ecosystems. Moreover, this study proposes an insightful groundwork for stimulating further research into the potential individual and situational elements that could shape responses towards E-learning acceptance.

Practically, these findings hold significant implications for both educators and platform providers. For educators, these insights underscore the need to devise E-learning environments that promote meaningful dialogue between instructors and learners, provide autonomy, and are well-structured, thereby fostering a sense or perception of ease and usefulness among learners. For platform providers, understanding that ease of use fuels perceived usefulness implies that continuous efforts should be emphasized on intuitive interface design and usability. This study provides a roadmap for improving learner reception and engagement by cultivating an awareness of the essential factors affecting their acceptance.

### LIMITATIONS

Despite its contributions, the current study exhibits some limitations. Primarily, the investigation assesses the impact of a mere three external variables on learners' inclination to utilize an E-learning Platform, potentially overlooking other variables that may influence platform acceptance. Therefore, future research could extend this study by exploring connections between additional variables and learners' technology acceptance, notably when engaging with a new learning system initially. Secondly, this study's context is framed within the first three months following the adoption of the E-learning platform. Students' perceptions pertaining to ease of use and usefulness of technology could evolve over time with increased usage experience. Consequently, conducting longitudinal research may provide a deeper understanding of the results of the current study, accounting for the evolution in learners' perceptions and behaviors over an extended duration.

### CONCLUSION

This study advances our understanding of learners' acceptance of E-learning platforms by examining the critical role played by structure, dialogue, and learner autonomy. It reveals a potent interconnection between perceived ease of use, perceived usefulness, and learner intention to use these platforms, elucidating how an intuitive, interactive, and learner-centric E-learning environment can catalyze learner engagement. While providing foundational insights, we encourage future research to delve deeper and assess other potential variables influencing learners' E-learning platform acceptance. With the digitalization of education becoming increasingly ubiquitous, such research holds transformative potential for shaping learner-centric online educational environments.

### ACKNOWLEDGMENT

This paper is sponsored by the Instructional Program of Philosophy and Social Sciences for Higher Education Institutions in Hubei Province (21G112).

### REFERENCES

- Akaslan, D., & Law, E. L.-C. (2011). Measuring student E-learning readiness: A case about the subject of Electricity in Higher Education Institutions in Turkey. In H. Leung, E. Popescu, Y. Cao, R. W. H. Lau, & W. Nejdil (Eds.), *ICWL 2011. LNCS, vol. 7048*, (pp. 209-218). Heidelberg: Springer.
- Al-Azawei, A., Parslow, P., & Lundqvist, K. (2017). Investigating the effect of learning styles in a blended E-learning system: An extension of the Technology Acceptance Model (TAM). *Australasian Journal of Educational Technology*, 33(2), 1-23.
- Al-Emran, M., Mezhuiev, V., & Kamaludin, A. (2018). Technology acceptance model in m-learning context: A systematic review. *Computers & Education*, 125, 1-41.
- Al-Fraihat, D., Joy, M., Masa'deh, R., & Sinclair, J. (2020). Evaluating E-learning systems success: An empirical study. *Computers in Human Behavior*, 102, 67-86.
- Cakir, R., & Solak, E. (2015). Attitude of Turkish EFL learners towards e-learning through Tam model. *Procedia - Social and Behavioral Sciences*, 176(C), 596-601.
- Barnard, L., Lan, W. Y., To, Y. M., Paton, V. O., & Lai, S. L. (2009). Measuring self-regulation in online and blended learning environments. *The Internet and Higher Education*, 12(1), 1-6. <https://doi.org/10.1016/j.iheduc.2008.10.005>
- Bolliger, D. U., & Inan, F. A. (2012). Development and validation of the online student connectedness survey (OSCS). *The International Review of Research in Open and Distributed Learning*, 13(3), 41-65. <https://doi.org/10.19173/irrodl.v13i3.1171>
- Chang, C., Yan, C., & Tseng, J. (2012). Perceived convenience in an extended technology acceptance model: Mobile technology and English learning for college students. *Australasian Journal of Educational Technology*, 28(5), 809-826.
- Cheng, Y. (2012). Effects of quality antecedents on e-learning acceptance. *Internet Research*, 22(3), 361-390.
- Charness, N., & Boot, W. R. (2016). Technology, gaming, and social networking. In W. K. Schaie & S. L. Willis (Eds.), *Handbook of the psychology of aging (8th ed., pp. 389-407)*. Cambridge, MA: Academic Press.
- Cheung, R., & Vogel, D. (2013). Predicting user acceptance of collaborative technologies: An extension of the technology acceptance model for e-learning. *Computers & Education*, 63(C), 160-175.
- Chow, M., Herold, D., Choo, T., & Chan, K. (2012). Extending the technology acceptance model to explore the intention to use second life for enhancing healthcare education. *Computers & Education*, 59(4), 1136-1144.
- Dabbagh, Nada. (2007). The online learner: Characteristics and pedagogical implications. *Contemporary Issues in Technology and Teacher Education*, 7, 217-226.
- Davis, F. D. (1986). A technology acceptance model for empirically testing new end-user information systems: Theory and results [PhD dissertation]. *MIT Sloan School of Management*.
- Davis, F. D. (1989). Perceived usefulness, perceived ease of use, and user acceptance of information technology. *MIS Quarterly*, 13, 319-340.
- Falloon, G. (2011). Making the connection: Moore's theory of transactional distance and its relevance to the use of a virtual classroom in postgraduate online teacher education. *J. Res. Technol. Educ.*, 43, 187-209. <https://doi.org/10.1080/15391523.2011.10782569>
- Garrison, R. (2000). Theoretical challenges for distance education in the 21st century: a shift from structural to transactional issues. *Int. Rev. Res. Open Distrib. Learn.*, 1, 1-17.
- Garrison, D., Anderson, Terry, & Archer, Walter. (2001). Critical Thinking, Cognitive Presence, and Computer Conferencing in Distance Education. *American Journal of Distance Education*, 15, 7-23. <https://doi.org/10.1080/08923640109527071>.
- Gorsky, P., & Caspi, A. (2005). A critical analysis of transactional distance theory. *Quart. Rev. Dist. Educ.*, 6, 1-11.



- Granić, A., & Marangunić, N. (2019). Technology acceptance model in educational context: A systematic literature review. *British Journal of Educational Technology*, 50(5), 2572–2593.
- Hao, S., Dennen, V. P., & Mei, L. (2017). Influential factors for mobile learning acceptance among Chinese users. *Educational Technology Research and Development*, 65(1), 101–123.
- Huang, F., Teo, T., & Zhou, M. (2019). Chinese students' intentions to use the Internet-based technology for learning. *Educational Technology Research and Development*, 68(1), 575–591.
- Huang, X., Chandra, A., DePaolo, C., Cribbs, J., and Simmons, L. (2015). Measuring transactional distance in web-based learning environments: an initial instrument development. *Open Learn*, 30, 106–126. <https://doi.org/10.1080/02680513.2015.1065720>
- Hrastinski, S. (2008). Asynchronous & Synchronous E-Learning. *Educause Quarterly*, 51-55.
- Liu, I., Chen, M., Sun, Y., Wible, D., & Kuo, C. (2010). Extending the TAM model to explore the factors that affect Intention to use an online learning community. *Computers & Education*, 54(2), 600–610.
- Madjar, N., Nave, A., & Hen, S. (2013). Are teachers' psychological control, autonomy support and autonomy suppression associated with students' goals? *Educational Studies*, 39(1), 43-55. <https://doi.org/10.1080/03055698.2012.667871>
- Massimo, P. (2014). Multidimensional analysis applied to the quality of the websites: Some empirical evidence from the Italian public sector. *Economics and Sociology*, 7(4), 128-138. <https://doi.org/10.14254/2071-789X.2014/7-4/9>
- Masrom, M. (2007). Technology acceptance model and E-learning. *Technology*, 21, 81
- Moore, M.G. The theory of transactional distance. In *Handbook of Distance Education*, 4th ed.; Keegan, D., Ed.; Routledge: London, UK, 1993; pp. 32–46
- Moore, M. G. (2012). The theory of transactional distance. In *Handbook of Distance Education*, ed. M. G. Moore (New Jersey: L. Erlbaum Associates).
- Nagy, J., McGreal, R., Kennepohl, D., & Blomgren, C. (2018). Evaluation of online video usage and learning satisfaction: An extension of the technology acceptance model. *International Review of Research in Open and Distributed Learning*, 19(1), 160–185.
- Persico, D., Manca, S., & Pozzi, F. (2014). Adapting the technology acceptance model to evaluate the innovative potential of e-learning systems. *Computers in Human Behavior*, 30, 614–622.
- Pekrun, R., Goetz, T., & Perry, P. R. (1991). A manual for the use of the motivated strategies for learning questionnaire (MSLQ). Ann Arbor: The University of Michigan.
- Pintrich, P. R., Smith, D. A. F., Garcia, T., & McKeachie, W. J. (1991). A manual for the use of the motivated strategies for learning questionnaire (MSLQ). Ann Arbor: The University of Michigan.
- Ros, S., Hernández, R., Caminero, A., Robles, A., Barbero, I., Maciá, A., & Holgado, F. (2015). On the use of extended TAM to assess students' acceptance and intent to use third-generation learning management systems. *British Journal of Educational Technology*, 46(6), 1250–1271.
- Sánchez, R., & Hueros, A. (2010). Motivational factors that influence the acceptance of Moodle using TAM. *Computers in Human Behavior*, 26(6), 1632–1640.
- Sang, G., Valcke, M., Braak, J., & Tondeur, J. (2010). Student teachers' thinking processes and ICT integration: Predictors of prospective teaching behaviors with educational technology. *Computers & Education*, 54(1), 103–112.
- Shannon, D. M. (2002). Effective teacher behaviors and Michael Moore's theory of transactional distance. *J. Educ. Lib. Inf. Sci.*, 43, 43–46. <https://doi.org/10.2307/40323986>
- Song, Y., Kong, S. (2017). Investigating students' acceptance of a statistics learning platform using technology acceptance model. *Journal of Educational Computing Research*, 55(6), 865–897.
- Sun, P., Tsai, R.J., Finger, G., Chen, Y., & Yeh, D. (2008). What drives a successful e-Learning? An empirical investigation of the critical factors influencing learner satisfaction. *Comput. Educ.*, 50, 1183-1202.
- Teo, T., & Noyes, J. (2011). An assessment of the influence of perceived enjoyment and attitude on the intention to use technology among pre-service teachers: A structural equation modeling approach. *Computers & Education*, 57(2), 1645–1653.
- Teo, T., Zhou, M., Fan, A. C. W., & Huang, F. (2019). Factors that influence university students' intention to use Moodle: A study in Macau. *Educational Technology Research and Development*, 67(3), 749–766.
- Venkatesh, V., & Bala, H. (2008). Technology acceptance model 3 and a research agenda on interventions. *Decision Sciences*, 39(2), 273–315.
- Yang, M., Shao, Z., Liu, Q., & Liu, C. (2017). Understanding the quality factors that influence the continuance intention of students toward participation in MOOCs. *Educational Technology Research and Development*, 65(5), 1195–1214.
- Yeou, M. (2016). An investigation of students' acceptance of Moodle in a blended learning setting using technology acceptance model. *Journal of Educational Technology Systems*, 44(3), 300–318.
- Zhou, M. (2016). Chinese university students' acceptance of MOOCs: A self-determination perspective. *Computers & Education*, 92, 194–203.

## Exploring IT Affordances and Risk Management for Internationalization Activities of Business Schools

Bob Nanthakorn <sup>1</sup>  
Peter Ractham <sup>2</sup>  
Phatsaporn Suwannakart <sup>3</sup>  
Lalita Damrungkunkamjorn <sup>4</sup>  
Noptanit Chotisarn <sup>5,\*</sup>

\*Corresponding author

<sup>1</sup> Thammasat Business School, Bangkok, Thailand, Research Associate, bob.nanthakorn@gmail.com

<sup>2</sup> Thammasat Business School, Bangkok, Thailand, Full-time Faculty Member, peter@tbs.tu.ac.th

<sup>3</sup> Rangsit University, Bangkok, Thailand, Lecturer, phatsaporn.s@rsu.ac.th

<sup>4</sup> Thammasat Business School, Bangkok, Thailand, International Affairs Officer, lalita.d@tbs.tu.ac.th

<sup>5</sup> Thammasat Business School, Bangkok, Thailand, Full-time Faculty Member, noptanit@tbs.tu.ac.th

### ABSTRACT

The COVID-19 pandemic had strong negative effects on all kinds of academic processes and forced business schools worldwide to use Information Technology (IT) artefacts to cope with the social distancing which prohibited most on-site activities from early 2020 until mid-2022. These effects were even more significant for universities with different types of international affairs activities. This paper explored these changes and constraints by investigating the IT affordances of a triple crown accredited business school during the three phases of the COVID-19 pandemic: before the pandemic (pre-2019), during the pandemic (early 2020 to mid-2022) and the post-pandemic (2022 onward). To reach this research aim, primary data from interviews with outgoing exchange students going abroad and incoming foreign exchange students from a leading business school in Thailand have been analyzed. As a central finding of this paper, it has been identified that IT affordances have changed significantly during the pandemic. More and different IT tools were implemented. Especially at the beginning of the pandemic many of the needed tools were not available and schooling to use them was missing. A high number of requests resulting from uncertainties on the student's side were communicated via various communication channels. Often these requests were not leading to sufficient replies. The communication model changed from unidirectional communication in the pre-pandemic phase to a bidirectional model in the pandemic phase. As a result of this paper, the authors suggest aligning IT affordances with a strategic risk management system. This newly derived model could support the international affairs units to utilize IT artefacts to help reduce the risks involved in future crises.

*Keywords:* COVID-19, education, IT affordances, International Program, Exchange Program, Exchange Students, International Affairs, Students, University, Thailand

### INTRODUCTION

Since the end of 2019, the global COVID-19 pandemic had major impacts on all kinds of global matters. By mid-July 2023, over 767 million reported cases, and over 6.9 million casualties were reported (WHO, 2023). To limit the spread of the COVID-19 disease, local health officials applied strict social distancing policies, domestic lockdowns, workplace closures, restrictions on movements, and both domestic and international travelling. Restaurants, bars, gymnasiums, factories, offices, and universities were forced to close during the height of the pandemic (Asongu *et al.*, 2021; Deb *et al.*, 2021).

The COVID-19 pandemic has affected various industries, especially airlines, leisure facilities, energy companies, the automotive industry, and restaurants (Haydon & Kumar, 2020). A total of 255 million people lost their full-time jobs during the pandemic, approximately 120 million people were pushed into poverty and a decline in the tourism sector by 74% (UN, 2021). For the year 2022 estimations see globally 52 million full-time jobs less compared to the situation before the crisis (Farge, 2022; WHO, 2021).

Moreover, in most countries, the universities were closed, and most activities were switched to online for all university stakeholders (ILO, 2022). This meant that during the pandemic, the universities had to utilize different types of IT artefacts to conduct online activities such as online classes for students, online meetings and conferences for professors and work-from-home for most administrative staff members. IT artefacts such as Zoom, Microsoft Team and Google Meet were being used extensively during the pandemic by most universities worldwide. However, most of the university's personnel including students, professors, and staff administrators were not prepared for a quick digital transformation to adapt online activities

through these IT artifacts (Kansal et al., 2021; Reimers, 2022). Nevertheless, most university stakeholders had to adjust and adapted to online activities “on-the-fly” by adapting different types of IT artefacts in different ways to respond to the pandemic.

The internationalization processes of universities were strongly affected, as they require to a large extent physical mobility and on-site presence. The main activities of international processes usually involve international mobility in terms of exchange students, international visiting professors and international conferences for researchers. By all accounts, international exchange students perhaps were the most affected by international restrictions during the COVID-19 pandemic in terms of international mobility. During the height of the COVID-19 pandemic, countries were locked down. For example, foreign exchange students who were studying in Thailand cannot return home because of the border shutdown. Also, Thai students who were studying abroad also cannot fly back to Thailand. Most on-site international conferences and meetings were cancelled and had to change to virtual conferences. The constraints from these effects for these stakeholders such as exchange students were uncertainty, changing living conditions, different ways to learn, financial hardship, health-related risks, and mental constraints (Bozkurt et al., 2020; Falk & Eva, 2021; Shrestha et al., 2022).

Mittelmeier et al., (2021) describe the increasing relevance of technology-supported internationalization processes within higher education. Hashim et al., (2021) highlight that “building competitive advantage is challenged by the digital revolution.” To cope with the situation, the international affairs administrations respond to these challenging internationalization requirements by using different types of IS artefacts to deal with the changing situations. This paper analyzes how the international affairs unit within a Triple Crowns (AACSB, EQUIS and AMBA) accredited business school utilizes IT affordances to cope with the COVID-19 pandemic. This paper aims to investigate how IT artefacts were used to facilitate international activities in detail and thereby learn the affordances as well as how the affordances were redefined from the lesson learned from the pandemic. The following research questions were defined:

1. How has the business school used IT artefacts to transform the internationalization processes during the COVID-19 pandemic?
2. Can these IT artefacts be used as risk management tools to help improve future situations or prevent future crises?

To answer these questions, in a first step a literature review has proceeded, and a conceptual model has been created. Using a case study method primary, qualitative data have been generated and evaluated.

## LITERATURE REVIEW

### Internalization Affairs in Business Schools

In the last few decades, major business schools around the world have increased the number of internationalization activities due to the increased level of globalization (de Wit & Ligia, 2020; Jampaklay et al., 2022). Cortés-Sánchez (2017) analyzed these missions and found a “trend towards global influence, an unsurprising emphasis on research and teaching, certain geographical patterns, and a noticeable focus on either the individual or process depending on whether a university was public or private”.

In the last years, there has been an increased strive for an increased internationalization of business schools worldwide. Internationalization is here seen as a way to integrate international, intercultural, and global perspectives into university activities and key functions. The motivation for this more intensified internationalization is a response to globalization. Drivers of this development are economic and political (e.g. economic growth, globalization of human resources, foreign policies) and cultural and educational (e.g. spreading social values, individual development support for students, attracting the best students and teachers globally) (Hawawini, 2016; Teixeira, 2021).

These internationalization approaches are usually managed and organized by the international affairs administration unit at the business school or at the university level. Incoming and outgoing exchange programs are developed, led, and managed in all phases: before the exchange (preparations), during the exchange (support), and post-program assistance (Mazon, 2010). Classically these activities are mainly done by personal contact between the internationalization affairs administration staff and the exchange students. To succeed in the internationalization affairs administration of the universities, a university needs academic facilities and resources to reach its mission: Space for teaching, research labs, office and technical equipment, administrative support, and information technology (IT) (Zinkiewicz, 2004).

Also, different types of IT technologies can be used by international affairs units in the university such as social media, websites, and applications for smartphones. Traditionally, international affairs units utilized IT to provide data and information via websites, newsgroups, and messenger services, and make online polls or chatbots to get feedback from both incoming and outgoing students. However, most of the international affairs activities pre-pandemic are still relying heavily.

### Effects of the COVID-19 Pandemic on Exchange Internationalization

With the outbreak of the COVID-19 pandemic, the classical concept of managing and organizing internationalization has interfered. Exchange students in all phases of their programs were facing major uncertainties and had a huge demand for information:

- Changing entry and visa restrictions
- Travel restrictions
- Language issues
- Health concerns
- Insurance issues
- Visa issues
- Shutdowns and distance learning

The classical approaches using mainly personal contacts were not or less possible. Additional and new demands for IT usage occurred. The IT affordances within internationalization changed as described in the following section (Tasci, 2021).

### Effects of the COVID-19 Pandemic on Exchange Internationalization

Gibson (1979) developed this theory and applied it to artefacts and animals. He stated “The affordances of the environment are what it offers the animal, what it provides or furnishes, either for good or ill. The verb to afford is found in the dictionary, but the noun affordance is not. I have made it up. I mean by it something that refers to both the environment and the animal in a way that no existing term does. It implies the complementarity of the animal and the environment.” He refers to an action possibility formed by the relationships between an object (e.g., artefacts or animals) and its environment as shown in Figure 1.

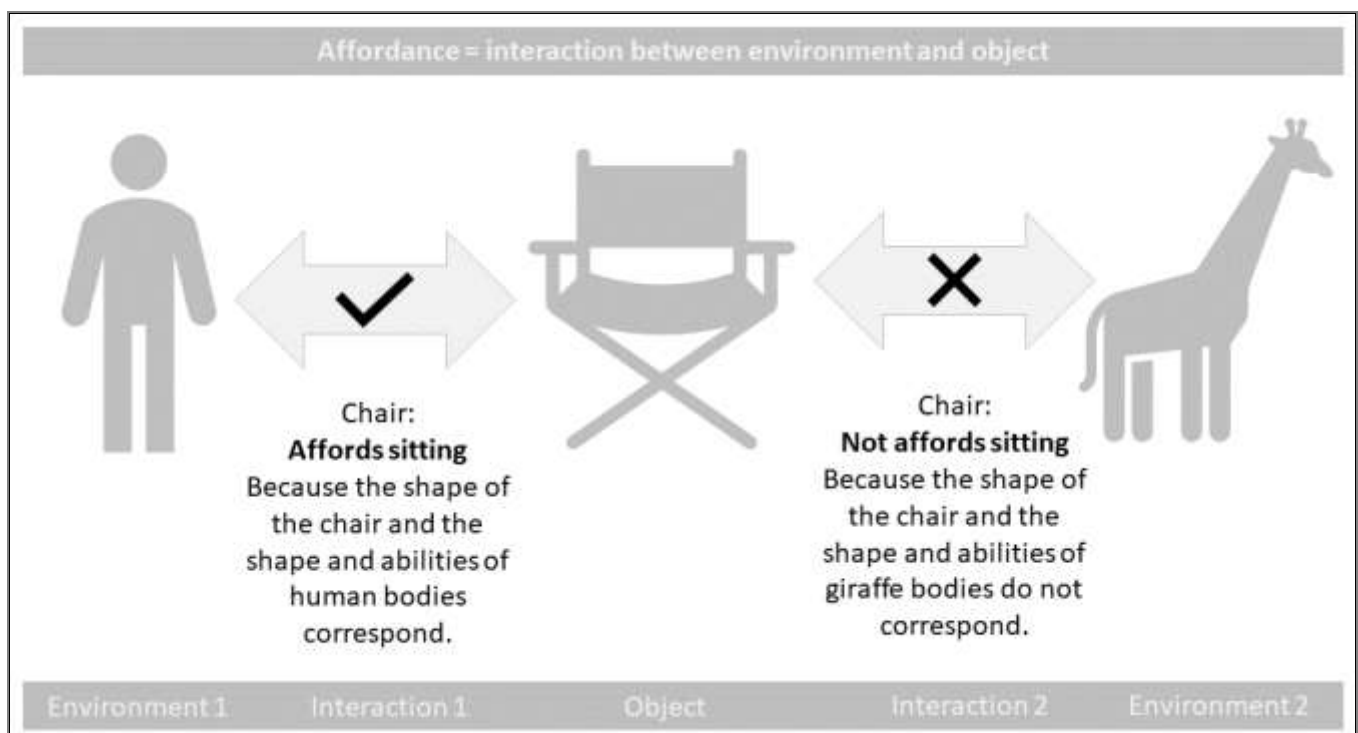

Source: Own figure based on Gibson, 1979, partly inspired by Alfonzo, 2005; Martin, 2017; Udacity, 2015.

Figure 1: Theory of Affordance

Since the initial theory was defined by Gibson more than 40 years ago, there has been a strong evaluation of the term affordances. The usage is today widely spread and used in very different circumstances (Chong & Robert, 2020). Gaver (1991) noted at the beginning of the 1990s that the term ‘affordance’ can be used to describe “strengths and weaknesses of technologies with respect to the possibilities they offer the people that might use them.” Applying Gibson’s theory nowadays to the field of modern technology refers to “an action potential, that is, to what an individual or organization with a particular purpose can do with a technology or information system” (Majchrzak, 2014). When getting more specific within the field of technology and applying this theory to IT, ‘affordances’ can be described as the relationship of a specific (→ environment) to an IT system or IT equipment (→ object).

Chatterjee et al. (2019) define IT affordances based on previous research as “the action potential of IT in an organization and can be understood as what the IT allows the human users to do.” Dong et al. (2016) highlight, that IT affordances emerge “since actors do not interact with an object prior to or without perceiving what the object is good for”.

Each IT system contains certain qualities offering opportunities while using them. Examples are: An online meeting app contains the quality to get in connection with people even when not being on-site at the university and offers the opportunity to teach online. An online library contains the quality to save and share knowledge and is offering the opportunity to proceed with research without going to an on-site library. The theory of qualities of an object that communicates opportunities to do certain actions is called ‘affordances’ (Britannica, 2022).

## Proposing a Conceptual Model

Within the different roles within higher education (here: students, administrative staff, teaching staff, and researchers), this paper is focusing on the role of students as shown in the conceptual model below (Figure 2).

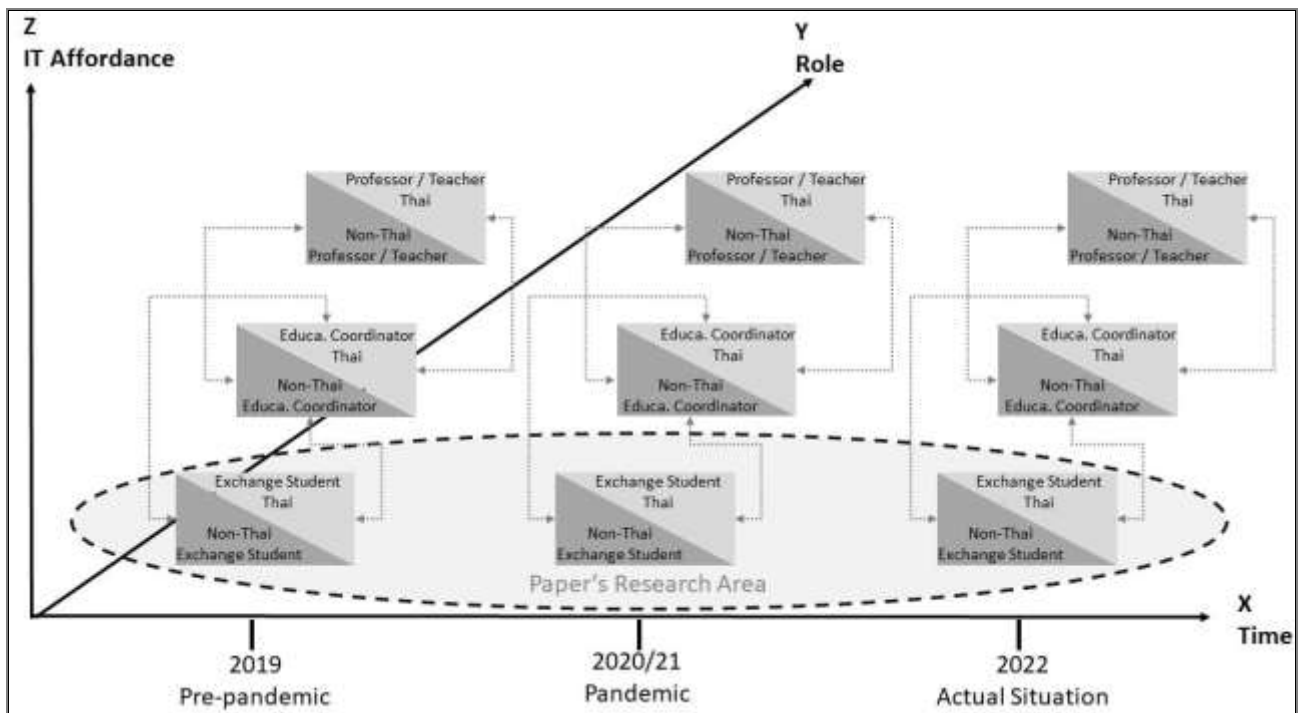

Source: Own figure.

Figure 2: Mapping the research area. Pre-pandemic, pandemic, Post pandemic scenarios exploring the IT affordances depending on the role within a university.

## METHODOLOGY

### Case Study Method

A case study method is applicable if a phenomenon needs to be analyzed. Yin (2011) describes it as an essential form within social science. It may be combined with other methods, such as for example surveys, experiments, or data analysis.

In this case, the research field and research aim were unique, as there has not been a comparable pandemic before. Therefore the possibility to work with secondary data was very limited. The researchers decided on gathering the primary, qualitative data via interviews because they give the chance to provide information in a very short period of time, the costs are comparatively low, and they offer the opportunity to ask additional questions if needed (Akbarak, 2000).

The chosen interview type was “semi-structured”. This means that the questions were defined before the interview but there was a possibility to ask additional questions if anything was unclear. As suggested by Griffiee (2005) additional details of the procedure of the interview have been defined.

### Data Collection

To find an interview partner, the research team defined criteria the participants would need to fulfil:

- Being an exchange student enrolled at a Thai (Incoming foreign students) or foreign university (Outgoing Thai students).
- Participant in an academic exchange program with a partner university abroad
- Proceeding the exchange during the COVID-19 pandemic
- Agreeing to take part in the research work

Applying these search criteria at an internal data bank of a Triple Crowns accredited business school in Thailand led to 54 search results. The 54 students meeting these criteria have been contacted via email explaining the research objectives. 22 students (response rate: 41%) replied by giving positive feedback. The key characteristics of these 22 students were:

- 13 female students, 9 male students
- 13 Thai students, 4 European students, 3 American students, and 2 students from other Asian countries
- 13 outgoing students, thereof 7 to Europe, 4 to other Asian countries, and 3 to America
- 9 incoming students (origin as non-Thai students above)

The key information of these participants is provided in an anonymous form in Table 1.

Table 1: The reference styles in the text.

Stakeholders	Questions
Students	<ul style="list-style-type: none"> <li>• Why did you choose (Thailand/Outgoing country) as your destination for your study?</li> <li>• How were your experiences when you were in (Country)?</li> <li>• When the pandemic hit... how did it affect your experience?</li> <li>• What types of risks do you think were the most dangerous as an international student during the time of the pandemic? How did you deal with them?</li> <li>• What types of information technology were needed for you to deal with various risks that come with the COVID-19 pandemic when you were in (Country)?</li> <li>• How did the school disseminate information related to COVID-19?</li> <li>• Did you use any types of IT? How did you use that IT to help you deal with your life and your study during the COVID-19 pandemic? Eg. LINE, Facebook, Website, social media, Email, Zoom, Microsoft Team, etc. <ul style="list-style-type: none"> <li>• Study</li> <li>• Traveling</li> <li>• Contact with University</li> <li>• Getting proper information</li> </ul> </li> <li>• Are there any obstacles to IT being used? What do you think of their advantages and disadvantages?</li> <li>• What are the risks involved in terms of Incoming/outgoing students? Visa, Traveling, Safety, Attending class?</li> <li>• How did you deal with various risks? How did you use IT to help reduce the risks?</li> </ul>

Source: This study.

The questions were shared with the interview subjects through e-mails prior to the interview dates. All questions have been asked as open-ended questions. An additional inquiry could be raised from both sides if needed. Individual meeting dates have been agreed upon with the interview partners. The interviews were made via the online meeting application ZOOM and took between 30-40 minutes between July and September 2021. Besides the interview subjects, at least two researchers joined every meeting meetings to ensure data collection integrity. All participants have been informed that they are taking part in research work and agreed to the usage of the research findings. None of the participants belongs to a group that would need special protection (e.g. minors).

After the interviews, the research team gathered and reviewed the recordings and transcribed the written notes. Information was analyzed and discussed among the research team members. The information has been segmented: They have been labelled according to their content and whether they can contribute to answering the research questions. In the second step, the segments were evaluated and clusters of information were identified. The findings have been noted and again discussed with the research team.

## FINDINGS

Following Mittelmeier et al, (2021) and Hashim et al., (2021) who stressed the relevance of IT-supported internationalization processes in higher education, the findings have been divided into three groups reflecting the three phases defined in the mapping of the research area visualized in Figure 2: Pre-pandemic, During the pandemic, and Post-pandemic actual IT affordances. The duration of these phases based on WHO (2023) can be defined as:

- Pre-pandemic, before December 2019, no COVID-19 cases
- During the pandemic, December 2019 to January 2022, altering increasing and decreasing global COVID-19 cases
- Post-pandemic, January 2022 onward.

### Pre-Pandemic IT Affordances

Most participants describe their IT affordances in this period as 'basic'. Their information needs were mostly linked to the basic academic processes of students. Examples mentioned were: Information about enrollment, courses, timetables, exchange programs, visa requirements, study results, social activities, and housing. The information direction was in most cases unidirectional: The students requested information and the university staff provided it. Most often this information was standardized (e.g. by forwarding text drafts or sending prepared files or providing links to existing websites). IT tools used in this period were mainly email applications (especially when corresponding with educational coordinators at the university), websites (e.g. the faculty homepages of the university providing general information about the academic program), and social media platforms (especially Facebook pages of the universities and their faculties).

Figure 3 shows the unidirectional communication model, which was common before the pandemic. Here the impulse for communication is coming from one side (the “attacker”, here: exchange student) and is directed to a second party (the “tacker”, here: university staff). A characteristic of this model is, that the reply is not given in the same form (or direction), but by providing standardized information.

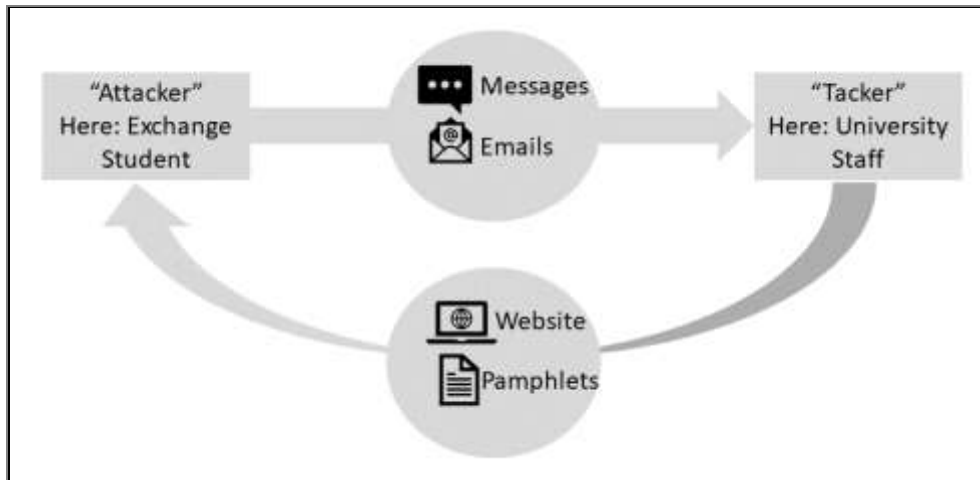

Source: Own figure partly based on Mouton et al. (2014).

Figure 3: Unidirectional communication model of exchange students in the pre-pandemic phase with an indirect reply from the university via standardized files.

### During-Pandemic IT Affordances

All interview partners highlighted very clearly, that with the outbreak of COVID-19, IT affordances increased and changed dramatically. A high level of uncertainty was leading to a high demand for information needs and support requests. Moreover, the academic process (e.g. visiting onsite lecturing and exams) was stopped or limited due to the closing of university campuses. Depending on the individual situation of the students, typical issues were:

- Future exchange student pre-departure: Uncertainty and a high level of information needed on whether the exchange program will be or should be started. Intense bidirectional communication with the educational coordinators via email. Online meetings between students and coordinators to discuss matters replacing onsite meetings. Close follow-up of the development of the pandemic in newsgroups, university websites, social media, and student online groups.
- Exchange student being abroad wanting to remain abroad: Uncertainty about the future of exchange program. Additionally, high constraints and a high level of information are needed in respect to health issues (e.g. preventive actions, procedures when being infected, vaccination processes, and health insurance coverages). Confusion and worries about following foreign guidelines and restrictions. The requested information is partly not available in English language. Issues resulting from changed or unclear immigration and visa processes. The teaching mission of the university partly stopped, partly on-site, and partly online. Usage of a vast amount of communication channels (email, messaging, social media, telephone), all kinds of platforms to gain and exchange information (university platforms, social media platforms, public websites, governmental websites, newsgroups), and different kinds of applications for online meetings (Zoom, Skype, GoToMeeting, Teams, Webex, GoogleMeeting, and others).
- Exchange students being abroad faced uncertainty, confusion, and constraints of need or wish to return home. Unclear information about requirements from the visited country, entry requirements from the local administration, and availability of incoming or outgoing international flights. Moreover, doubts and vagueness about whether the studies can be continued at their home university. Strong need for bidirectional communication and exchange: High number of requests raised from the student side. Need to individually respond on the university, governmental, and flight company sides. Usage of all kinds of communication channels. Nearly all relevant students described that there were often no or very insufficient answers given.

In this period the direction of information often got bidirectional. Besides the above-described issues from the students, the university had issues organizing and communicating their administrative matters and providing teaching content to the students. The administrative and teaching staff at the university previously were used to mainly unidirectional communication. Mostly standardized information had been used in the past. The new demands in connection with the pandemic hit many universities being insufficiently prepared. Capacities and tools were not available to sufficiently satisfy the demands, especially in the early stages of the pandemic. Step by step universities adapted their processes to fulfill these demands as well as possible.

### Post-Pandemic IT Affordances

A key finding from the interviews with experts is, that after experiencing the constraints of the pandemic for nearly two years, many students show a more reflective way of viewing the latest changes in IT affordances. Expert highlighted very clearly, that most of the students have learned the hard way, that sudden unplanned demands were not satisfied sufficiently. All kinds of IT



tools they were used to work with, were not able to solve their new demands. They received additional, new tools which were often not well explained. Moreover, high variance and inconsistency in tools occurred. Especially in the early phase of the pandemic. This led to a great level of confusion, demotivation, and disappointment on the student's side and was often described as annoying and blocking their learning progress. Their demands, worries, remarks, and fears remained often unheard as all parties were fully unprepared for such constraints. Resulting of this, many interview partners defined demands to master the actual pandemic and potential comparable situations:

- Definition of the IT process: Students highlighted the demand for clearly defined IT processes: A definition of responsibilities, communication channels, emergency procedures, defined timing, and process escalation levels.
- Set-up of IT toolbox: Students suggested defining a standard set of IT tools. These tools shall cover all kinds of basic and exceeded demands of university processes. They shall be easily accessible (e.g. by download on the university portal), be free of cost for students, and consist of instructions that have been schooled.
- Gaining from "Lesson Learned": Several students mentioned that they missed information about experiences and learnings from students who were in the same situation as they were. They suggested finding a way to share this information with them to prevent them from going through the same learning process and to gain from experiences from the 'senior students'.

## DISCUSSION

The findings from the interviews have shown insufficiency in the actual management of IT affordances within universities. The additional IT demands explored in this research were in most cases exceeding the capabilities of processes that the university provides. To more efficiently manage the ongoing or future pandemic, the researchers suggest setting up a risk management system by using IT artefacts as a main tool to respond to future crises. The recommendations are as follows:

### Identify Risk Governance

The aim of this group of tasks is to develop an awareness of risks on the side of all stakeholders. It is not a new formal process but rather the aim to implement risk awareness into all relevant processes. An important role plays the upper management which shall be highly aware of the risks and animate all stakeholders to build up a risk-related culture. "Risk management is an important and necessary management that makes accurate decisions based on the level of risk" (Samimi, 2020). Risk governance should consist of "openness, transparency, participation, inclusion, deliberation, and reflexivity; that experts involved should be open to questioning the situation; should not conceal issues of uncertainty and pluralism" and should be understood as a set of attempts to raise risk-awareness (Lidskog, 2017).

### IT Risk Evaluation

The initial step of a risk evaluation process is the identification of the risks and how IT can be used as Risk Respondents. In the second step, the identified risks are analyzed and assessed using defined criteria (Oehmen et al., 2010; Refsdal et al., 2015). Already in the 1990s, an article from Charette (1997) highlighted the benefits of risk analysis but at the same time already highlighted its risks. "Although risk analysis and management processes are generally straightforward, they are in no way cookbook recipes. The different choices made in how the analysis and management process are implemented will affect its overall effectiveness." Wee et al. (2012) and Al-Dhahri et al. (2017) highlight the need for risk identification following a risk analysis to have a risk evaluation.

### IT Risk Response

After having identified and evaluated the risks in previous steps, a final step of responding to each risk must be defined. Based on Trinh et al. (2018) and Wikarsa (2014) there are different approaches to cope with such risks:

- Avoidance: Strategy to eliminate risk, especially by eliminating the cause of the risk.
- Transference: Strategy to transfer or share the risk, especially by transferring to a different company.
- Mitigation: Strategy to reduce the impact of a risk, especially by decreasing the likelihood that the risk will occur.
- Acceptance: Strategy to accept that risk can occur, especially by being prepared for the consequences resulting from a risk.

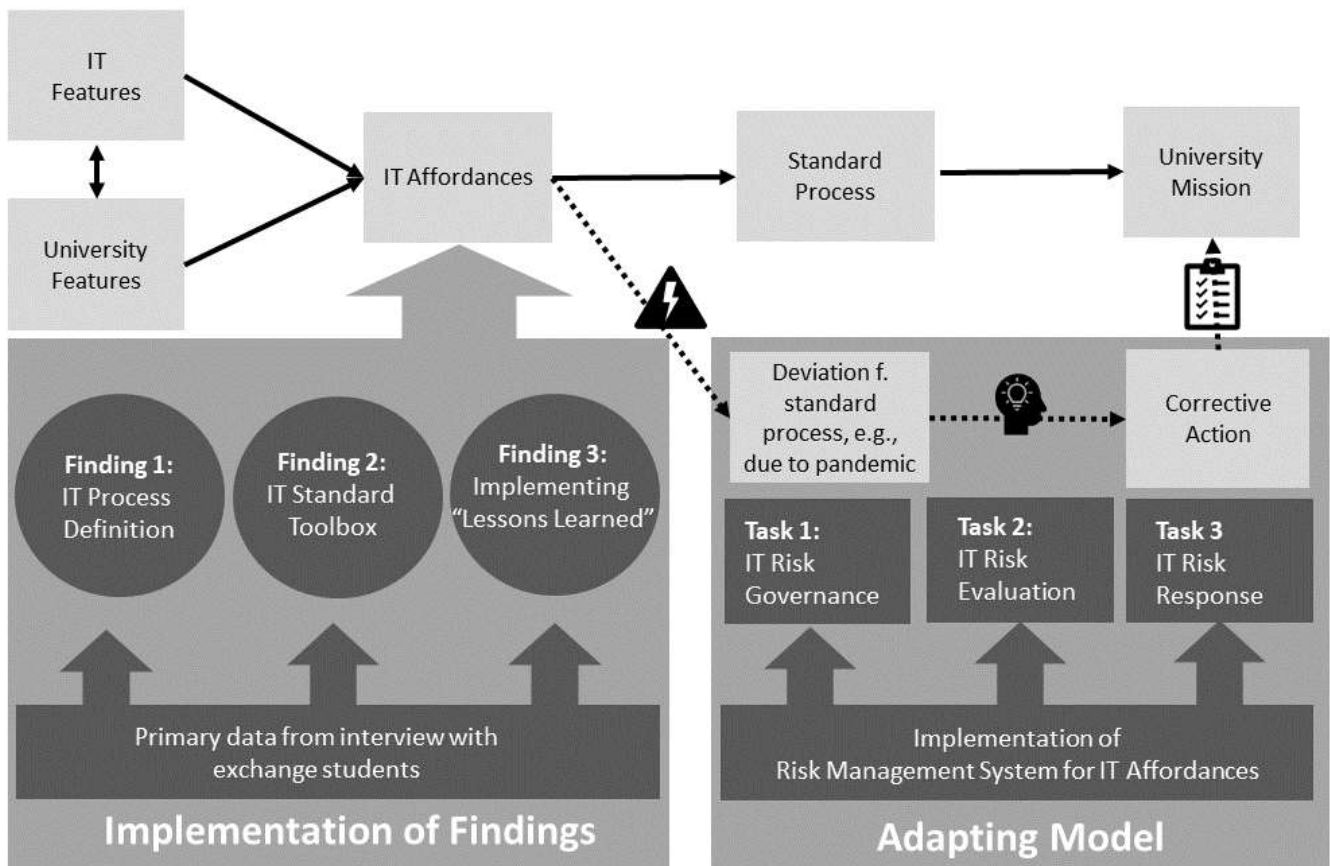

Source: Own figure.

Fig. 4. Implementing findings into a model of IT affordances (ref. figure 1) and adapting the model by adding a risk management system.

These results and recommendations can be used to extend the initial model of IT affordances. The findings from the interviews with the students are deriving the IT affordances. IT processes, IT standard tools, and the “Lessons Learned” are respected to satisfy the needs to secure a standard process of reaching the university mission. Moreover, the risks are being evaluated and responses for each risk are being developed. The new, extended model can be found in Figure 4.

This model might be a matter for testing in future research. Moreover, the researchers propose future research on the relationship and dependencies between the different variables, e.g. by analyzing differences between in- and outgoing students by performing statistical analysis.

## CONCLUSION

This research work has shown, that IT affordances are changing when constraints occur in the standard process of fulfilling the central university mission of transferring and generating knowledge. These changes need to be managed to fulfil the university’s mission efficiently. The information requirement changed as the pandemic unfolded. As a result, IT needed to adapt to these new requirements, which led to constraints. In this study, the IT affordances theory has been used to execute a case study of internationalization affairs activities at Thammasat University and to illustrate how IT can be adapted to fit different needs, including emerging needs.

The findings show that IT with some delay in time had the needed flexibility to adapt to these needs. The newly requested systems, software, and hardware have been available. Nevertheless, it must be stated that this delay in time was leading to major constraints on the university side and students’ side. Uncertainty and risks resulting from this uncertainty occurred. Due to the importance of IT in fulfilling the university’s mission, the researchers suggest implementing a risk management system to lower the risk of such constraints for future comparable situations.

## REFERENCES

- Akbayrak, B. (2000). A comparison of two data collecting methods: interviews and questionnaires. *Hacettepe Üniversitesi Eğitim Fakültesi Dergisi*, 18(18), 2000.
- Al-Dhahri, S., Al-Sarti, M., & Aziz, A. A. (2017). Information Security Management System. *International Journal of Computer Applications*, 158(7), January 2017.
- Alfonzo, M. A. (2005). To walk or not to walk? The hierarchy of walking needs. *Environment and Behavior*, 37, 808-836, 2005.

- Asongu, S. A., Diop, S., & Nnanna, J. (2021). The geography of the effectiveness and consequences of Covid-19 measures: Global evidence. *Journal of Public Affairs*, 21(4), 2021.
- Bozkurt, A., Jung, I., Xiao, J., Vladimirsch, V., Schuwer, R., Egorov, G., & Paskevicius, M. (2020). A global outlook to the interruption of education due to COVID-19 pandemic: Navigating in a time of uncertainty and crisis. *Asian Journal of Distance Education*, 15(1), 1-126, 2020.
- Britannica - Encyclopædia Britannica Inc. (2022). Affordance - psychological theory. In J. J. Gibson; <https://www.britannica.com/science/affordance>.
- Charette, R. N. (1997). Managing the Risks in Information Systems and Technology. *Advances in Computers*, 44, 1-58, 1997.
- Chatterjee, S., Moody, G. D., Lowry, P. B., Chakraborty, S., & Hardin, A. (2019). Actualizing Information Technology Affordance for Organizational Innovation: The Role of Organizational Courage. *Journal of Strategic Information Systems (JSIS)*, Accepted 04-Dec. 2019.
- Chong, I., & Robert, W. P. (2020). On the evolution of a radical concept: Affordances according to Gibson and their subsequent use and development. *Perspectives on Psychological Science*, 15(1), 117-132, 2020.
- Cortés-Sánchez, J. D. (2017). What do universities want to be? A content analysis of mission and vision statements worldwide. In *London School of Economics and Political Science - LSE Impact of Social Sciences blog*; published December 20th, 2017.
- de Wit, H., & Ligia, D. (2020). Internationalization of higher education, challenges and opportunities for the next decade. In A. Curaj et al. (Eds.), *European Higher Education Area: Challenges for a New Decade*, Springer, pp. 3-11, 2020.
- Deb, P., Furceri, P. D., & Ostry, J. D. (2021). The Economic Effects of COVID-19 Containment Measures. *Open Econ Rev*, 2021.
- Dong, X., Wang, T., & Benbasat, I. (2016). IT Affordances in Online Social Commerce: Conceptualization Validation and Scale Development, 2016.
- Falk, M. T., & Eva, H. (2021). When international academic conferences go virtual. *Scientometrics*, 126(1), 707-724, 2021.
- Farge, E. (2022). Global jobs recovery delayed by pandemic uncertainty, Omicron, ILO says. In *Reuters*; article published online January 17, 2022.
- Gaver, W. W. (1991). Technology Affordances. In *Conference Proceedings: Conference on Human Factors in Computing Systems, CHI 1991, New Orleans, LA, USA, April 27 - May 2, 1991*.
- Gibson, J. J. (1979). *The Ecological Approach to Visual Perception: Classic Edition*. Psychology Press & Routledge Classic Editions, 1st Edition, first published in 1979, Chapter 8.
- Griffiee, D. T. (2005). Research Tips: Interview Data Collection. *Article*; January 2005.
- Hashim, M., Tlemsani, I., & Matthews, R. (2021). Higher education strategy in digital transformation. *Educ Inf Technol*, 27, 3171-3195 (2022). <https://doi.org/10.1007/s10639-021-10739-1>
- Hawawini, G. (2016). The Internationalization of Higher Education and Business Schools - A Critical Review. In *Hawawini, G. The Internationalization of Higher Education and Business Schools - A Critical Review*. SpringerBriefs Business, 2016, eBook ISBN 978-981-10-1757-5.
- Haydon, D., & Kumar, N. (2020). Industries Most and Least Impacted by COVID19 from a Probability of Default Perspective September 2020 Update. In *S&P Global Market Intelligence*, published 21 Sep, 2020.
- ILO - International Labour Organization (2022). WESO Trends 2022 - ILO downgrades labour market recovery forecast for 2022. *Article published 17 January 2022*.
- Jampaklay, A., Benjamas, P., & Aksarapak, L. (2022). Internationalization of higher education in Thailand: Promises and reality. *Kasetsart Journal of Social Sciences*, 43(1), 183-193, 2022.
- Kansal, A. K., Gautam, J., Chintalapudi, N., Jain, S., & Battineni, G. (2021). Google trend analysis and paradigm shift of online education platforms during the COVID-19 pandemic. *Infectious Disease Reports*, 13(2), 418-428, 2021.
- Lidskog, R. (2017). Risk Governance. In *Oxford University Press*, Published online: 27 July 2017.
- Majchrzak, A. (2014). Technology Affordances. In *Encyclopedia of Management Theory*, January 2014.
- Martin, R. (2017). Affordances. *Article and video*, published April 9, 2017.
- Mazon, B. K. (2010). Taking the global leap: Student affairs professionals and internationalization. *Research in Comparative and International Education*, 5(2), 205-209, 2010.
- Mittelmeier, J., Rienties, B., Gunter, A., & Raghuram, P. (2021). Conceptualizing Internationalization at a Distance: A “Third Category” of University Internationalization. *Journal of Studies in International Education*, 25(3), 266-282. <https://doi.org/10.1177/1028315320906176>.
- Mouton, F., Louise, L., Mercia, M. M., & Venter, H. S. (2014). Towards an ontological model defining the social engineering domain. In *IFIP International Conference on Human Choice and Computers*, pp. 266-279. Springer, Berlin, Heidelberg, 2014.
- Oehmen, J., Mohammad, B-D., Warren, S., & Muhammad, A.-S. (2010). Risk management in product design: Current state, conceptual model and future research. In *International Design Engineering Technical Conferences and Computers and Information in Engineering Conference*, vol. 44090, pp. 1033-1041, 2010.
- Refsdal, A., Solhaug, B., & Stølen, K. (2015). Risk Evaluation. In *Cyber-Risk Management*, October 2015.
- Reimers, F. M. (2022). Learning from a pandemic. The impact of COVID-19 on education around the world. In *Primary and secondary education during COVID-19*, pp. 1-37. Springer, Cham. 2022.
- Samimi, A. (2020). Risk Management in Information Technology. *Progress in Chemical and Biochemical Research*, 3, 130-134; 2020.

- Shrestha, S., Saifa, H., Saraswati, D., & Ram, A. G. (2022). Preparations for and practices of online education during the Covid-19 pandemic: A study of Bangladesh and Nepal. *Education and information technologies*, 27, 243-265, 2022.
- Tasci, G. (2021). The impact of COVID-19 on Higher Education: Rethinking internationalization behind the iceberg: COVID-19 and Higher Education. *International Journal of Curriculum and Instruction*, 13(1), 522-536, 2021.
- Teixeira, G. C. d. S. (2021). Internationalization of business schools and their strategic response to institutional complexity; Dissertation for the degree of Doctor of Philosophy in Business Administration, FGV Sao Paulo School of Business Administration.
- Trinh, B.-N., Huynh, Q.-T., Nguyen, X.-T., Ngo, V.-Q., & Vu, T.-T. (2018). Application of Nash equilibrium based approach in solving the risk responses conflicts. *Journal of Science and Technology - Le Quy Don Technical University*, 193, 2018.
- Udacity (2015). Definition: Affordance - Intro to the Design of Everyday Things. *Video*, published 24 Feb 2015.
- UN - United Nations (2021). How COVID-19 is changing the world: a statistical perspective - Volume III. *The Committee for the Coordination of Statistical Activities (CCSA)*.
- Wee, H., Blos, M., & Yang, W-H. (2012). Risk Management in Logistics. *Intelligent Systems Reference Library*, 33, 285-305.
- WHO - World Health Organization (2021). Coronavirus disease (COVID-19). *Article from 13 May 2021*.
- WHO - World Health Organization (2023). WHO Coronavirus (COVID-19) Dashboard. *Update from 12:14 pm CEST, 12 July 2023*; <https://covid19.who.int/>.
- Wikarsa, L. (2014). Risk Management for IT Projects, *Article*, 2014.
- Yin, R. K. (2011). *Applications of Case Study Research*. Publisher SAGE, 2011; Edition 3; ISBN 1452235783, 9781452235783.
- Zinkiewicz, L. (2004). Postgraduate Supervision and Support in Psychology: A Review of Good Practice. *Article*, published April 2004.

## Exploring the Influence of AI on Purchase Intention of Electric Vehicle among Consumers in China

Ning Fang<sup>1,\*</sup>  
Worawan Ongkrutraksa<sup>2</sup>

---

\*Corresponding author

<sup>1</sup> Graduate student, Chulalongkorn University, Bangkok, Thailand, fning106@gmail.com

<sup>2</sup> Professor, Chulalongkorn University, Bangkok, Thailand, Worawan.o@chula.ac.th

### ABSTRACT

As China swiftly recovers from the impacts of COVID-19, the nation grapples with complex development challenges, notably the promotion of green energy consumption. Despite environmental awareness among consumers in China growing but which not led to a parallel increase in the consumption of green products. Bridging this gap necessitates effective communication and communication tool, based on previous studies, AI was believed to be a pivotal tool for sustainable economy. Therefore, this study focuses on AI and China's electric vehicle (EV) industry which is a prominent sector in green energy. Employing the technology acceptance model to explore the influence of perceived usefulness (PU), perceived ease of use (PEU), perceived cyber risks (PCR), and perceived enjoyment (PE) of AI on consumers' purchase intention for EV in China.

*Keywords:* AI, Electric Vehicle, Purchase Intention, Green Marketing Communication, The Technology Acceptance Model.

### INTRODUCTION

China's GDP growth is rebounding after COVID-19, driven by manufacturing and urbanization, but this success poses environmental challenges (O'Neill, 2023). Despite a rise in environmental consciousness among consumers, the adoption of green products hasn't surged (J. Liang et al., 2022). Therefore, green marketing communication becomes crucial in bridging this gap, necessitating a clear and effective communication channel.

Artificial Intelligence (AI) emerges as a significant tool in the realm of environment and helps companies doing the sustainably economy (Rathore, 2018). AI is a broad concept, compare the other AI technologies, AI chatbots are widely used in people's daily life, for example, Ernie Bot (Huang et al., 2022). This kind of AI known for their natural language interaction and versatility, it can provide consumers with personalized and unambiguous content, it perfectly can deal with the complexity of green products (Ghoreishi & Happonen, 2020; Huang et al., 2022; Ongkrutraksa, 2022). Therefore, this paper focuses on AI chatbots and utilizes the Technology Acceptance Model (TAM), extending it to include perceived cyber risks (PCR) and perceived enjoyment (PE) as additional factors. This ensures a holistic understanding of consumer behavior towards AI chatbots in the context of green marketing (Lee et al., 2019).

Because electric vehicle (EV) is seen as one of the most effective ways to mitigate global warming, so Chinese government spent over several billion dollars to support the purchase of EV, for example, exempt from a vehicle purchase tax. But the market sales in China have been slowing down, therefore this paper delved into this green product industry (Liu et al., 2023).

The research not only fills existing gaps in comprehending AI chatbots' role in green marketing and consumer behavior, particularly in the EV industry, but also sheds light on AI's potential to address climate crises, rather than being a threat.

## LITERATURE REVIEW

This research gathers information from past studies; prevailing theories, current articles, and relevant documents to use them as a background source for conducting its study and propose the following topics.

AI plays a vital role in China, and it has a broad impact across different sectors, for example, medicine, and the education field. It has been developing Chinese' economy, and social development, improving human life (Abonizio et al., 2023; Chipman Koty, 2021; McKinsey, 2022). However, AI is a double-edged sword, not only bringing benefits to China but also taking challenges, such as job displacement (Danmeng & Jia, 2018; Shen, 2020). To address these challenges, maximize AI's benefits, and make people accept this technology. Letting people see AI as an important and effective way to help them improve their lives is essential. AI is a broad branch of computer science. This paper only focuses on AI chatbots, which is a software program that uses AI to understand consumers' questions and automatically respond, simulating human conversation, such as Chinese companies introduced Ernie Bot; Tongyi; Qianwen. Due to its natural language interaction, accessibility, personalization, and versatility, it is one of the most popular AI that consumers use in daily life to help them find more useful information (Huang et al., 2022). Especially in recent years, AI chatbots is making a wave in China, so this paper takes Chinese chatbots as examples to investigate (Brown, 2023a).

In the 21st century, addressing environmental challenges has become a paramount concern for humanity. Therefore, seizing the opportunity to use AI to assist in solving these challenges is imperative. Green marketing strategies can play a pivotal role to prove that AI can collaborate with humans to effectively address environmental issues and contribute to the betterment of society. The goal of green communication is to transmit detailed information to consumers about the company's green products, commitments, efforts, and results in the field of environmental protection and quality of life (Danciu, 2006; Mera, 2003; Ongkrutraksa, 2007). When green product companies communicate information about the performance of their products, they usually convey it in either ambiguous or precise presentation, how information on green products is presented to consumers has an impact on their decision to buy (S. Liang et al., 2022). Therefore, finding an effective communication tool is key, based on previous studies, Artificial intelligence has played a key role in revolutionizing eco-friendly marketing strategies, providing systems and tools to predict consumer behavior, and generating personalized marketing insights and opportunities (Brown, 2023b; Rathore, 2018).

While AI chatbots have proven to be valuable tools for marketing and customer service, their adoption can be influenced by various factors, especially when companies use it to promote green products. Therefore, it is necessary to use TAM to explore consumers' adoption towards AI chatbots. The Technology Acceptance Model (TAM) describes an individual's acceptance of information systems (Lucas Jr & Spitler, 1999). This model has been widely used to explain and predict what factors influence organizations and individual users to accept and use a specific technology (Rauschnabel & Ro, 2016). In the Technology Acceptance Model, there are two main dimensions, which include perceived ease of use (PEU) and perceived usefulness (PU) (Davis et al., 1989). Based on the criticisms of TAM and society development, this paper chooses perceived cyber risks (PCR) and perceived enjoyment (PE) as another two main factors to explore consumers' acceptance of AI and whether these factors (PU, PE, PEU, PCR) have impact on purchase intention (Abdullah & Ward, 2016; Kakabadse et al., 2008; Kim & Forsythe, 2008; Pantano & Di Pietro, 2012; Wang et al., 2018). With people's self-awareness increased and the widespread use of technology in daily life, they are more care about their psychology, thus using perceived enjoyment is essential, it can measure how much a certain system's use is seen as pleasant in and of itself, without regard to any negative effects on performance. For perceived cyber risks, this factor is often seen as the major barrier to user adoption of innovative technologies (Wang et al., 2018). Perceived cyber risks refer to an individual's subjective assessment of potential cyber security threats and vulnerabilities. These perceptions are shaped by numerous factors and can influence decision-making, behavior, and cyber security practices.

Consumer purchase intention is a key driver of a company's green marketing success, but it is influenced by a complex interplay of factors (Gogoi, 2013). So, the Technology Acceptance Model (TAM) provides a framework that lets marketers



analyze consumers' purchase behavior. Businesses and marketers can use this model to design and market products, thereby increasing purchase intention among potential customers. A marketer must comprehend the purchasing intention to determine whether a consumer's attitude toward environmental communications is related to their desire to buy the promoted goods because of the relationship between attitude and behavior.

In this paper, researchers chose the EV industry as an example to explore. Based on previous studies, the adoption of EV is crucial in mitigating air pollution and reducing carbon emissions. China as the world's biggest national market for EV, there has a bright future, especially the Chinese government committed to achieve carbon neutrality by 2060. Therefore, EV is currently being introduced as one of the most efficient solutions to help people protect the world. The Chinese government has been introducing a lot of policies to help EV industry, for example, price subsidies for electricity, oil, and purchase subsidies, purchase tax exemptions (Yan & Crookes, 2007). However, there is one big problem China has been facing, even if the number of electric car (EV) on the road has been increasing but their market shares are still lower than traditional ICEVs (Lin & Wu, 2018). Not only because the COVID-19 damages but also public awareness, willingness to buy, and technology diffusion is still at a low (Liu et al., 2023). Therefore, finding an effective new communication tool for this industry is urgent.

In summary, this paper's literature review underscores Artificial Intelligence (AI) is a double-edged sword, but AI especially AI chatbots can help green marketing to maximize their benefits to help humans. Leveraging the Technology Acceptance Model (TAM), the research delves into consumers' acceptance of AI chatbots, incorporating factors like perceived cyber risks and perceived enjoyment. The examination of China's electric vehicle (EV) industry underscores its potential for environmental mitigation, backed by governmental support. Despite the growing popularity of EV, challenges persist in capturing market shares, underscoring the necessity for holistic approaches in green marketing and AI integration.

### **HYPOTHESIS**

- H1: Perceived usefulness (PU) of AI affects consumers' purchase intention towards EV.  
 H2: Perceived ease of use (PEU) of AI affects consumers' purchase intention towards EV.  
 H3: Perceived enjoyment (PE) of AI affects consumers' purchase intention towards EV.  
 H4: Perceived cyber risks (PCR) of AI affects consumers' purchase intention towards EV.

### **RESEARCH METHODOLOGY**

The research is based on a quantitative approach aiming to explore the effects of PU, PEU, and PE, PCR of AI on the purchase intention of Electric Vehicle among consumers in China. This chapter describes the details of the research sample and sampling method, research tool, variable measurement, and data collection and data analysis. The study utilizes an online questionnaire survey to collect information and plan to use multiple regression analysis. Based on the literature review and previous studies, the questionnaire was categorized into 8 sections: screening questions, 5-point Likert scale charts about PU, PEU, PE, PCR, and purchase intention (PI) towards EV. A purposive sampling method involved 300 participants for data collection. The sample of this study is people who live in Shanghai city, aged between 31-40 years old because they are the main buyers of EV and have high education level and income, and they must meet the requirements that they have intention to use AI chatbots and EV or have experience using any AI chatbots and EV.

### **DATA ANALYSIS AND RESULTS**

The Statistical Package for the Social Sciences (SPSS) is employed to analyze the primary data collected from research questionnaire in this study.

#### **Reliability Analysis**

The SPSS test concluded that: The overall reliability coefficient value of the scale is  $\alpha=0.906$ , indicating good internal consistency and stability of this questionnaire in general. At the same time, the coefficient of reliability value  $\alpha$  of each subscale is greater than 0.8, indicating that each subscale had good stability. The conclusion is that the reliability of the data



reliability of this scale is good.

Table 1: Reliability

Construct	Cronbach $\alpha$	Items
Perceived usefulness (PU)	.873	5
Perceived ease of use (PEU)	.851	4
Perceived enjoyment (PE)	.852	4
Perceived cyber risks (PCR)	.877	4
Purchase intention (PI)	.825	3

The Cronbach's alpha value for PU, PEU, PE, PCR scales are all over 0.8, ensuring high reliability of the scale. Moreover, these values are in concurrence with the original scale which all had reliability over 0.7 (Holdack et al., 2022; Liu, 2022; Vafaei-Zadeh et al., 2022; Woo & Kim, 2019).

### Validity Analysis

The structural validity of the scale was tested by exploratory factor analysis, and the test results are shown in table 2. The KOM value is 0.887, and the Bartlett's sphericity test showed  $P < 0.01$ . This indicates that the overall validity of the questionnaire is good.

Table 2: KMO and Bartlett

KMO and Bartlett		
KMO		0.887
	Approx. Chi-square	3056.465
Bartlett	df	190
	P	<0.01

### Descriptive Statistics

The SPSS test concluded that: The gender distribution among respondents is nearly equal, with 49.7% males and 50.3% females, while none fall into the "others" category. In terms of monthly income, the largest group comprises 49.0% of respondents earning between 7,001-9,000 RMB, followed by 40.3% earning more than 9,000 RMB. Regarding education, the majority (73.3%) hold a bachelor's degree, followed by 18.0% with education beyond a bachelor's, 6.7% with a secondary school level, and 2.0% with education below secondary school.

### Multiple Regression Analysis

The study uses data to test the influence of independent variables on dependent variables through multiple regression analysis. The results are shown in Table 3.

Table 3: Results of Multiple Regression Analysis

Variable	B	SE	95% CI	$\beta$	t	P
(constant)	0.669	0.238	0.201		2.816*	0.005
PU	0.235	0.062	0.113	0.216	3.786*	0.01
PEU	0.096	0.059	-0.19	0.092	1.641	0.102
PE	0.235	0.057	0.122	0.222	4.095*	0.01
PCR	0.232	0.056	0.121	0.228	4.113*	0.01

Note:  $F= 33.543$ ,  $R^2 = 0.313$ ,  $R^2_{adj} = 0.303$ ,  $*p < 0.01^b$

There are four independent variables that positively affect the dependent variables: (1) the perceived cyber risks (PCR) got highest Beta score= 0.228; (2) the perceived enjoyment (PE) variable with Beta = 0.222, followed by (3) the perceived usefulness with Beta=0.216 (4) the last variable (PEU) with Beta= 0.092, meaning that when the samples perceived the usefulness, ease of use, enjoyment, and cyber risks of AI Chatbots, their intention to purchase EV would be positively affected. Four independent variables (PU, PEU PCR, and PE) can explain the relationship between dependent variables (PI) for 30.30 percent. However only three variables (PU, PE, PCR) are statistically significant less than 0.05. Therefore H1, H3, H4 are supported.

## Results

The hypotheses testing was conducted by using SPSS, to produce coefficients, statistical significance of influence (As shown in Figure 1).

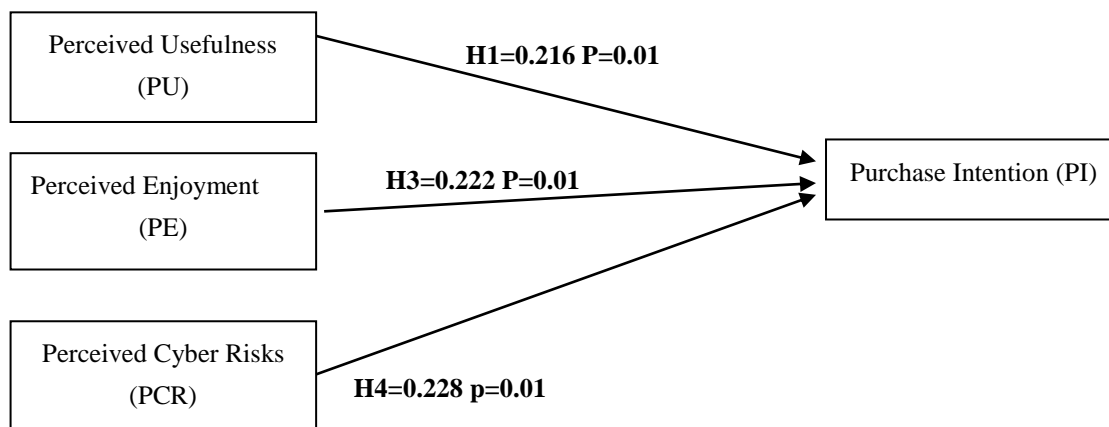

Figure 1. Hypothesis tests using SPSS

## DISCUSSION

1. Perceived cyber risks (PCR) received the highest Beta score, highlighting the pervasive influence of personal information security concerns in an increasingly technology-driven world. In the contemporary landscape, individuals are increasingly wary of potential risks to their personal information. These results align consistently with prior research, which states that cyber risks is a very important factor to influence them use a specific technology and then influence their behavior (Al-Adwan et al., 2023).
2. Perceived enjoyment (PE), there is a notable connection between respondents' PE of AI chatbots and their subsequent purchase intention toward electric vehicles (EVs). These results align consistently with prior research, particularly the

work of Venkatesh (2000) and Liu (2022). Notably, there has been a noteworthy shift in people's self-awareness, with an increasing recognition of the importance of personal happiness. In recent years, the evaluation of technology has extended beyond mere functionality; individuals now consider whether a particular technology can contribute to their happiness, which has become a crucial benchmark in deciding whether they will continue to engage with that technology.

3. Perceived usefulness (PU) is one of the influential variables on PI, but only can rank third among all variables. Respondents believe that using AI chatbots can be a good assistant to help them to do the shopping. Previous studies have reached consistent conclusions in most contexts, including the paper (Mensah, 2020), The convenience of obtaining real-time information, coupled with the ability to navigate through various options effortlessly, strengthens the belief that AI chatbots are instrumental in shaping a high-quality consumption experience for consumers interested in electric vehicles.
4. Perceived Ease of Use (PEU) positive impact on purchase Intention (PI); however, the absence of strong evidence indicates that consumers' perceptions may be influenced by the complexity of electric vehicle information and the limited popularity and functionality of domestic AI chatbots compared to global counterparts. This outcome does not align with the results reported by Liu (2022).

### Research Implications

This research contributes significantly to the understanding of Technology Acceptance Model (TAM), AI chatbots, purchase intention toward electric vehicle (EV), and green marketing strategy. While previous studies focused on factors like subsidy policies, business models, and challenges in EV purchase intention, the study innovatively explores AI chatbots as a new marketing communication tool in the context of green marketing. The findings emphasize the positive impacts of AI chatbots on perceived usefulness, ease of use, enjoyment, and cyber risks on purchase intention, providing valuable insights for academic research and practical implications for businesses. Marketers are advised to leverage AI chatbots as effective and efficient tools, emphasizing their positive influences and addressing concerns to enhance consumer engagement and purchase intentions.

Additionally, the study highlights the business implications of the findings, based on this paper results, marketers are advised to accentuate the enhanced personal information security offered by AI chatbots compared to other communication tools, and promote the experience use AI chatbots to get information is fun, not boring, so it can attractive consumers attention. Besides marketers should be aware of that usefulness in AI chatbot also will be a point to let consumers use this technology to get products information, therefore should highlight AI chatbots can help their life more productivity, save money and time. In order let consumer aware of the ease of use of AI chatbots, marketers should offer clear instructions on how to effectively engage with AI chatbots, highlighting their user-friendly features, and demonstrating the simplicity of incorporating these tools into daily information-seeking routines. When consumers see AI chatbots advantages and use it, this technology will influence their purchase decision. Overall, the research offers a comprehensive understanding of the intersection between AI chatbots, green marketing, and consumer behavior, paving the way for strategic advancements in technology-driven marketing approaches.

### REFERENCES

- Abdullah, F., & Ward, R. (2016). Developing a General Extended Technology Acceptance Model for E-Learning (GETAMEL) by analysing commonly used external factors. *Computers in Human Behavior*, 56, 238-256.
- Abonizio, H. Q., da Costa Barbon, A. P. A., Rodrigues, R., Santos, M., Martínez-Vizcaíno, V., Mesas, A. E., & Junior, S. B. (2023). How people interact with a chatbot against disinformation and fake news in COVID-19 in Brazil: the CoronaAI case. *International Journal of Medical Informatics*, 105134.
- Al-Adwan, A. S., Li, N., Al-Adwan, A., Abbasi, G. A., Albelbisi, N. A., & Habibi, A. (2023). Extending the technology acceptance model (TAM) to Predict University Students' intentions to use metaverse-based learning platforms.

*Education and Information Technologies, 1-33.*

- Brown, T. (2023a). The AI chatbot phenomenon is now making waves in China, too.
- Brown, T. (2023b). The AI chatbots phenomenon is now making waves in China.
- Chipman Koty, A. (2021). "Artificial Intelligence in China: Shenzhen Releases First Local Regulations". *china-briefing*.
- Danciu, V. (2006). Marketing ecologic: etica verde a producției și consumului. *Editura Economică*.
- Danmeng, M., & Jia, D. (2018). AI May Worsen Structural Unemployment in China: Report.
- Davis, F. D., Bagozzi, R. P., & Warshaw, P. R. (1989). User acceptance of computer technology: A comparison of two theoretical models. *Management science*, 35(8), 982-1003.
- Ghoreishi, M., & Happonen, A. (2020). Key enablers for deploying artificial intelligence for circular economy embracing sustainable product design: Three case studies. *AIP conference proceedings*.
- Gogoi, B. (2013). Study of antecedents of purchase intention and its effect on brand loyalty of private label brand of apparel. *International Journal of Sales & Marketing*, 3(2), 73-86.
- Holdack, E., Lurie-Stoyanov, K., & Fromme, H. F. (2022). The role of perceived enjoyment and perceived informativeness in assessing the acceptance of AR wearables. *Journal of Retailing and Consumer Services*, 65, 102259.
- Huang, W., Hew, K. F., & Fryer, L. K. (2022). Chatbots for language learning—Are they really useful? A systematic review of chatbot-supported language learning. *Journal of Computer Assisted Learning*, 38(1), 237-257.
- Kakabadse, N. K., écile Rozuel, & Lee-Davies., L. (2008). "Corporate Social Responsibility and Stakeholder Approach: A Conceptual Review." *International Journal of Business Governance and Ethics*, 1(4), 277–302.
- Kim, J., & Forsythe, S. (2008). Adoption of virtual try-on technology for online apparel shopping. *Journal of interactive marketing*, 22(2), 45-59.
- Lee, J., Kim, J., & Choi, J. Y. (2019). The adoption of virtual reality devices: The technology acceptance model integrating enjoyment, social interaction, and strength of the social ties. *Telematics and Informatics*, 39, 37-48.
- Liang, J., Li, J., & Lei, Q. (2022). Exploring the influence of environmental values on green consumption behavior of apparel: A chain multiple mediation model among Chinese Generation Z. *Sustainability*, 14(19), 12850.
- Liang, S., Zhang, M., Chu, Y., & He, L. (2022). Should “Green” Be Precise? The Effect of Information Presentation on Purchasing Intention of Green Products. *Sustainability*, 14(16), 10291.
- Lin, B., & Wu, W. (2018). Why people want to buy electric vehicle: An empirical study in first-tier cities of China. *Energy Policy*, 112, 233-241.
- Liu, B., Song, C., Liang, X., Lai, M., Yu, Z., & Ji, J. (2023). Regional differences in China's electric vehicle sales forecasting: Under supply-demand policy scenarios. *Energy Policy*, 177, 113554.
- Liu, Y. (2022). THE CHINESE PEOPLE’S INTENTION TO PARTICIPATE IN LIVESTREAM ENVIRONMENTAL MARKETING COMMUNICATIONS BASED ON THE TECHNOLOGY ACCEPTANCE MODEL (TAM)
- Lucas Jr, H. C., & Spitzer, V. (1999). Technology use and performance: A field study of broker workstations. *Decision sciences*, 30(2), 291-311.
- McKinsey. (2022). China’s AI potential.
- Mensah, I. K. (2020). Factors influencing the intention of international students to shop online in China. *International Journal of E-Business Research (IJEER)*, 16(3), 20-41.
- Mera, A. C. (2003). El etiquetado ecológico: un análisis de su utilización como instrumento de marketing *Universidad de Extremadura*.
- Ongkrutraksa, W. (2022). Exploring Young Consumers’ Exposure, Attitude, and Behavioral Response to YouTube Video Game Streaming’s Product Placement. *International Journal of Electronic Commerce Studies*, 13(3), 45-68.
- Ongkrutraksa, W. Y. (2007). Green marketing and advertising. *The debate over corporate social responsibility*, 365-378.
- Pantano, E., & Di Pietro, L. (2012). Understanding consumer’s acceptance of technology-based innovations in retailing. *Journal of technology management & innovation*, 7(4), 1-19.
- Rathore, B. (2018). Emergent Perspectives on Green Marketing: The Intertwining of Sustainability, Artificial Intelligence, and the Metaverse. *International Journal of New Media Studies: International Peer Reviewed Scholarly Indexed Journal*,

5(2), 22-30.

- Rauschnabel, P. A., & Ro, Y. K. (2016). Augmented reality smart glasses: An investigation of technology acceptance drivers. *International Journal of Technology Marketing, 11*(2), 123-148.
- Shen, X. (2020). China says AI robots won't lead to significant job loss.
- Vafaei-Zadeh, A., Wong, T.-K., Hanifah, H., Teoh, A. P., & Nawaser, K. (2022). Modelling electric vehicle purchase intention among generation Y consumers in Malaysia. *Research in Transportation Business & Management, 43*, 100784.
- Wang, S., Wang, J., Li, J., Wang, J., & Liang, L. (2018). Policy implications for promoting the adoption of electric vehicles: Do consumer's knowledge, perceived risk and financial incentive policy matter? *Transportation Research Part A: Policy and Practice, 117*, 58-69.
- Woo, E., & Kim, Y. G. (2019). Consumer attitudes and buying behavior for green food products: From the aspect of green perceived value (GPV). *British Food Journal, 121*(2), 320-332.
- Yan, X., & Crookes, R. (2007). Study on energy use in China. *Journal of the Energy Institute, 80*(2), 110-115\*.

## Factors Affecting Intention of Use Electronic Ticket Service of State Railway of Thailand Passengers

Woranon Chana <sup>1,\*</sup>  
Siriluck Rotchanakitumnuai <sup>2</sup>

\* Corresponding author

<sup>1</sup> Master Student, Thammasat University, Thailand, woranon-cha64@tbs.tu.ac.th

<sup>2</sup> Professor, Thammasat University, Thailand, siriluck@tbs.tu.ac.th

### ABSTRACT

This thesis studied factors influencing passenger intention to use the State Railway of Thailand (SRT) electronic ticketing (e-ticketing) system. Quantitative research was done, applying the theory of acceptance and use of technology, incorporating factors from previous research and new investigations of digital readiness and cost switching. The sample group comprised 208 passengers inexperienced in using the SRT website online ticketing system or D-Ticket application (app). Data was collected by electronic questionnaire and analyzed. Results were that environmental and cultural aspects of digital usage affect perceived systemic benefits, which in turn influenced the intention to use the system. In addition, factors related to expectations about the system's effectiveness directly impacted the intention to use the system. Samples perceived service costs as associated with switching costs from traditional ticketing channels, including time and convenience considerations. Sample educational levels influenced the intention to use the system. Limits with this research include the primary focus on examining the influence on the intention of passengers inexperienced with online ticketing services to use the SRT electronic ticketing system. Therefore, findings may not be relevant to other contexts. Further research might focus on different sample groups to generalize results. These findings may be useful for online ticketing service providers to enhance systems to better meet customer needs.

*Keywords:* Passenger intention, State Railway of Thailand (SRT), Electronic ticketing system, E-ticketing.

### INTRODUCTION

State Railway of Thailand (SRT) is a state enterprise under the Ministry of Transportation that offers rail conveying and transportation. The main transportation services are divided into 2 categories 1. Commercial Train Service which requires fee payment with several optional services e.g., air conditioning, overnight staying, food service, and non-regular route service. Passengers usually use the services for traveling for leisure, for commuting, and for non-daily use basis e.g., special express trains, express trains, and fast trains. 2. Public Service Trains are the 3<sup>rd</sup> class trains that service regular routes daily and the passengers using this type of service are daily passengers e.g., regular trains, suburban trains, and local trains (State Railway of Thailand, n.d.). In the past, SRT offered a computational ticket acquisition and seat reservation service called STARS-2 (Seat Ticketing and Reservation System Stage 2) with 444 stations available. After the attempt was made on the improvement of ticket acquisition service by hiring an outsource company to handle it for 20 years from 2000-2020. The contract was terminated in August 2020. Additionally, the original STARS-2 service has many technical limitations which is unable to offer digital ticket acquisition service. Therefore, to improve the ticket acquisition and seat reservation service to be more convenient, fast, and simple for the passengers, SRT has hired an outsource company to proceed with the ticket acquisition and seat reservation service so-called D-Ticket or electronic ticket acquisition and seat reservation service by e-bidding. SRT has started a new contract with the new company from November 2020 for prompt and continuous improvement as well as serving the objective of satisfying the passengers of SRT.

D-Ticket system can be divided into 2 categories as follows: 1. Offline Service e.g., at the front desk of all train stations, Call Center 1690, Automatic Ticket Vending Machines (TVM) in an early phase, it can be used for non-reserved seats, and Ticket Vending On Train (TVT) for ticket checking on board and ticket acquisition at the train station or non-ticket acquisition locations 2. Online service e.g., Internet Ticketing System: i-Ticket via [www.dticket.railway.co.th](http://www.dticket.railway.co.th) and Mobile Application (Mobile Ticketing System: M-Ticket) called SRT D-Ticket which is available on iOS and Android shown in Figure 1.



Figure 1: An interface of D-Ticket website by State Railway Thailand (<https://www.dticket.railway.co.th>)

The purpose of this research is to develop a parameter model that influences online ticket adoption decisions including 1. The influences of digital and academic knowledge (education levels) on the understanding of benefits and its associated parameters. 2. The influences of the cost of changes and education levels on the understanding of the cost of changes and its associated parameters. 3. The main causes of the influences of the cost of change, understanding of benefits, system acceptance, reliability, and education levels that might affect the online ticket acquisition decision. 4. The associated causes of education levels and the cost of changes on the system acceptance, risks, and reliability on the online ticket acquisition decision. Please note that the simple group has to have experience with the offline ticket acquisition system before including the front desk, middleman, or call center 1690 at least once, and never have experience buying the tickets online via the website or D-Ticket application.

## METHODOLOGY AND METHODS

This study is a quantitative research that aims to understand the influences of the online ticket acquisition decision of passengers by surveying with a questionnaire from a simple group. The questionnaire is made based on literature reviews, theories, and other research, research methodology can be as follows:

### Population and Sample Group

#### *Studied Population*

The sample group is Thai passengers who have purchased the ticket offline at least once but never purchased a ticket online via D-Ticket.

#### *Sample Randomization*

In this study, nonprobability sampling is applied via judgment sampling which the sample group has to experience the ticket acquisition offline (e.g., at the train station, agents or call center 1690) at least once and never purchased tickets online (e.g., website or D-ticket application of SRT).

#### *Number of Sample Group*

The sample group size can be calculated from an equation from Hair et al. (2021), it was said that the recommended sample group should have at least 5 to 10 times the indicators in this study, 42 questions are applied thus the number of sample group should be at least 210 samples.

### The Design of Questionnaires

In this study, an online questionnaire is applied for data collecting purposes via social media platforms e.g., Line application, Facebook, and sent through acquaintances as well as through the courtesy of SRT. The questionnaires can be subdivided into 4 including:

Questions regarding the usability of the ticket acquisition and seat reservation system (D-Ticket): The screening of the passengers who have never purchased the tickets online via D-Ticket but have purchased the ticket at the train stations leading the the next part for the introduction of the system.

Basic information of ticket acquisition and seat reservation system (D-Ticket): An explanation of the details, function, and basic system utilization.

Questionnaires regarding ticket acquisition and seat reservation (D-Ticket): Questions about different parameters e.g., the acceptance and utilization of technology, understating the cost of change, reliability, and risks, and the intention of service use using a 5-point Likert scale as follows: 1 point means strongly disagree. 2 points means disagree. 3 points means neutral. 4 points means agree. 5 points means strongly agree. Questions regarding the basic information of passengers e.g., age, education level, occupation, and open-ended questions.

### Research Design



This study used electronic questionnaires via online platforms as a data collecting system for the convients of respondents by a uniform resource locator on Facebook in a train passengers Facebook group and Line. The spreading of questionnaires started from April to May 2023.

### **Reliability of Research Tools Analysis (Pre-Test)**

The data collected from a sample group (Pre-test) of 30 samples is done to examine the questions according to theories or the same idea boundaries by the consideration of Cronbach's alpha coefficient which the result should be in the range of 0-1. The Cronbach's alpha coefficient should be greater than 0.7.

### **Data analysis**

#### ***Statistic Hypothesis Examination***

The examination of missing data from the questionnaires and data analysis using the normality test is used to verify the univariate outlier by its skewness in the range of  $>-3$  or  $<+3$  as consideration criteria via frequency statistic distribution.

#### ***Description Statistic***

The description statistic used to describe the personal information of each individual by distributing and presenting in frequency, percentage of the sample group, and the average of standard deviation against different parameters influenced the intention of D-Ticket utilization and presented in a table form.

#### ***Research Hypothesis Test and Analysis of Covariance (ANCOVA)***

This tool is used for comparison of statistical results by variables controlled between the education level group of the respondents.

## **RESULTS AND DISCUSSION**

From the data collection of the sample group, the analysis and discussion can be portrayed as the demographic data, verification of accuracy and reliability of data, verification of data distribution, and research hypothesis testing.

### **Verification of Accuracy and Reliability of Data (Data Screening)**

#### ***Verification of Qualification of Respondents***

This study analyzes the parameters that influence the intention of the electronics ticket acquisition system with 266 sets of questionnaires answered by respondents in which the respondents have never experienced the online ticketing system via D-Ticket. Thus, to screen the respondents in order to meet the research qualification, this screening criteria was applied. The results have shown that there were 58 respondents not meet the qualification resulting in the remaining 208 sets of questionnaires which can be calculated to 99.05%.

### **Sample Group Demographic**

The personal details regarding the questions of the sample group include ages, genders, education levels, occupations, and monthly incomes. From the qualified sample group of 208 people, it was found that 52.88% of all respondents are female, the age between 31-40 years old consisted of 37.98%, the age of 41-50 years old consisted of 34.13%, education levels of bachelor's degree/equal consisted of 75.96%, 36.06% of respondents are government officers/public servants/state enterprises, corporate workers consisted of 34.13%, and the monthly income of 15,000-30,000 Baht consisted of 54.92%.

### **Hypothesis Test and Analysis of Covariance (ANCOVA)**

There are a variety of train passengers with different demographics which can be divided into different groups and these groups have different effects on each variable. For this reason, demographic characteristic of education levels is used as a sample group and the parameter from the independent variable is used as an intervening variable for the analysis of covariances (ANCOVA). From the sample group, the results have shown that the education level of bachelor's degree or equal consisted of 158 respondents while 34 respondents have master's and doctoral degrees education and 16 respondents have lower than bachelor's degree education level.

### ***The Influences of Skills, Ecosystems, Technical Infrastructure, and Education Level on the Perceived Usefulness of D-Ticket System Use***

When analyzing the variants of the influences of each parameter on the perceived usefulness, the results found that the significant level is 0.69 which is greater than 0.05 which indicates that the independent variable has different variants. From the general linear model analysis, the adjusted predicted coefficient (Adjusted  $R^2$ ) is 48.8% indicating that the digital ecosystem influences the perceived usefulness which the significant p value is lower than 0.05 meaning the acceptance of the hypothesis (H2) with the regression coefficient (Beta) of 0.576. Moreover, the independent variable—technical skill does not have a direct influence on the perceived usefulness of the D-Ticket system. After covariance analysis, it was found that the education level lower than bachelor's degree co-influences with skills affected perceived usefulness on D-Ticket system use with the regression coefficient (Beta) of 1.023 indicating that this sample group are digitally skillful and can understand the benefits of D-Ticket system more than other sample groups since this group is familiar with technology use e.g., work-related or on the daily basis which has a more significant influence than the master's and doctor's degree education level sample group. Furthermore, it was found that the lower than bachelor's degree sample group is co-influenced by technical infrastructure on the perceived usefulness of D-Ticket system use which the regression coefficient consisted of -0.840 indicates that this sample group who has access to basic

infrastructures e.g., the internet or mobile phones has lower perceived usefulness than those who of master's and doctor's degree significantly. The latter is already equipped with devices and access which is why they have more experience with different systems thus D-Ticket system might be similar to those systems they have experienced before resulting in lower perceived usefulness.

#### ***The Influences of Monetary Cost, Time Taken, Efforts Convenience and Education Levels on Perceived Switching Value of D-Ticket System Use***

From the analysis of variants stability on the influences of perceived switching value on D-Ticket system use, the significant interval is 0.56 which is greater than 0.05 indicating that the independent variables have different variants. From the general linear model analysis used for hypothesis testing of the influence of perceived switching value of D-Ticket system use as well as hypothesis testing by variants analysis, it was found that the adjusted  $R^2$  is 47.5% and shown that the time taken, efforts convenience and education level (bachelor's degree or equal) has significant interval  $p$  lower than 0.05 which indicates to the acceptance of hypothesis H5, H6, H15 as well as the regression coefficient (Beta) of 0.443, 0.476, 1.371 respectively in which the education level has the greatest influence on the perceived switching value (1.37 times greater than the master's and doctoral degree) or the regression coefficient (Beta) equals to 1.37. Additionally, the monetary cost-independent variable does not have an effect on the perceived switching value of D-Ticket system use. After the covariance analysis, the education level of a bachelor's degree or equal influences the time taken which affects the perceived switching value of D-Ticket system use with a -0.315 regression coefficient value indicates that this sample group has a lower perceived switching value of D-Ticket system use than those of higher education levels significantly. This might be due to the perspective of this sample group that found no significant change in the time utilization of the system including traveling to buy the tickets time, learning time, and application installation time.

#### ***The Influences of Performance Expectancy, Effort Expectancy, Social Influences, Perceived Usefulness, Perceived Switching Value, Risk, Trust and Education Level on the Intention of D-Ticket System Use***

From the analysis of variants stability on the influences of perceived switching value on D-Ticket system use on the intention of D-Ticket system use, it was found that the significant interval is 0.145 which is greater than 0.05 indicating that the different independent variables have different variants. Moreover, from the general linear model analysis used for hypothesis testing of the influence of perceived usefulness of D-Ticket system use as well as hypothesis testing by variants analysis, the adjusted  $R^2$  is 62% which the main influence variable is the independent value of performance expectancy and the perceived usefulness that has the significant value  $p$  lower than 0.05 meaning the acceptance of hypothesis (H7 and H10), the regression coefficient (Beta) of 0.473 and 0.595 respectively, and effort expectancy, social influences, perceived switching value, risk, trust, and education level does not have a direct influence on the intention of D-Ticket system use. Furthermore, from the covariance analysis, it was found that the sample group of bachelor's degree or equal co-influences the perceived switching value of the D-Ticket system more than the higher education group significantly. This may be due to the previous sample group understanding the change from offline to online already and still having an intention to use D-Ticket system. Additionally, it was found that the sample group with lower than bachelor's degree education level co-influences with trust that also affects the intention of D-Ticket system use with the regression coefficient (Beta) of -0.624 indicates that this sample group does not trust the system in comparison to the group with higher than bachelor's degree education system significantly in which the intention of D-Ticket system use is lower than other groups. The results might be due to the perspective of this sample group which thinks trust is irrelevant to the intention of D-Ticket system used.

### **Results and Discussions of Research Hypothesis Testing**

#### ***The Relationships Between Digital Skills and Perceived Usefulness of D-Ticket System Use***

From the hypothesis test, the results show that digital skills do not have a significant interval of 0.5 which disagrees with hypothesis 1 that said digital skills have a positive influence on the perceived usefulness of D-Ticket system and the study of Cetindamar Kozanoglu and Abedin (2021) who found that the technology knowledges help improve the capability of learning about the system use. However, the result of the influence of education level on the perceived usefulness of D-Ticket in which the sample group with lower than bachelor's degree education level with technology skills has higher perceived useful than other groups which agrees well with Nikou et al. (2022) who found that technology skills have a direct influence on the convenience of technology use. In comparison, the groups of bachelor's degree and higher education level have lower perceived usefulness since they do not find D-Ticket system useful.

#### ***The Relationships Between Digital Ecosystem and Culture on the Perceived Usefulness of D-Ticket System Use***

The result indicates that the digital ecosystem and culture influence the perceived usefulness of D-Ticket system use which agrees well with Hammerton et al. (2021) who found that the digital ecosystem and culture which is one of the components leading to different practices in different ecosystems of technology use including social ecosystem, access to technology e.g., local society and urban society which have different accesses to opportunity.

#### ***The Relationships Between Technology Infrastructure on Perceived Usefulness of D-Ticket System Use***

This study found that digital systems and infrastructure has no statistically significant interval of 0.05 which disagrees with hypothesis 3 that said digital systems and infrastructure have a positive influence on the perceived usefulness of D-Ticket system use and also disagrees with digital systems and infrastructure principle which is a digital system and technology use for

convenient supporting the appropriate digital platform use e.g., automation production technology and robotic [Soomro et al., 2020]. However, the result agrees well with the work of Alshammari et al. (2016) who found that useful technical support and the acceptance of technology by users lead to a positive result but in contrast with this, there will be an obstacle in the perceived usefulness of new technology. Therefore, when comparing the result to the statistical analysis of this research found no positive supporting explanation for the hypothesis of the influence of technology infrastructure on D-Ticket system use which results in a negative way. This may be due to responders not finding D-Ticket system useful in several ways including devices, an appropriate platform, stability of the system, and internet access thus these parameters have a negative effect on the perceived usefulness of D-Ticket system.

#### ***The Relationships Between Monetary Cost on Perceived Switching Value of D-Ticket System Use***

The result shows that there is no significant interval of 0.05 on the monetary cost on perceived switching value of D-Ticket system use which disagrees with hypothesis 4 that says monetary cost has a positive impact on the perceived switching value of D-Ticket system use as well as the concept from Soomro et al. (2020) who found that with the increase in monetary cost, the customers can recognize it and lead to the change in service further. Furthermore, the result agrees well with several studies including Viitikko (2023) who found that the perceived switching value of Facebook users in Finland does not affect the intention of Facebook use and Aishah and Kassim (2019) who found that system acceptance and switching to electronic payment of Malaysia customers has a low to none effect on the acceptance of electronic payment significantly since there is little options in the electronic payment and the internet access is not good enough in some areas which agrees well with Tiwari and Tiwari (2020) who found that monetary recognition has no significant effect for Indian mobile banking. In conclusion, there is no supporting explanation for the hypothesis of the positive impact of monetary cost on the perceived switching value of D-Ticket system since many passengers do not want to pay additionally to gain special benefits in comparison to other purchasing platforms as a result, passengers do not see the importance of switching to D-Ticket system.

#### ***The Relationships Between Time Taken on Perceived Switching Value of D-Ticket System Use***

The result from this study agrees well with Soomro et al. (2020) who found that the increase in time taken resulted in the recognition of passengers and led to switching to D-Ticket service.

#### ***The Relationships Between Convenient Efforts on Perceived Switching Value of D-Ticket System Use***

The result agrees well with Jiang et al. (2013) who found that the services with direct help for the customers in selecting, providing the knowledge, and the use increase the satisfaction of the customers and affect re-purchasing which is convenient for evaluation, searching, and transaction. The after-service has an impact on the recognition of the customers in purchasing goods.

#### ***The Relationships Between Performance Expectancy on the Intention of D-Ticket System Use***

The result agrees well with Susanto et al. (2018) who found that effort expectancy has the most impact on behavior efforts and performance expectancy is also another parameter that affects the intention of use. For this study, the performance expectancy shows the time taken for the system to work or the good experiences of users which impact the intention of D-Ticket system use.

#### ***The Relationships Between Effort Expectancy on the Intention of D-Ticket System Use***

The result shows that there is no significant interval of 0.05 which disagrees with hypothesis 8 that said effort expectancy has a positive effect on the intention of D-Ticket system use and the study of Susanto et al. (2018) who found that the effort expectancy is the most important parameter influences the behavior effort and performance expectancy in which it leads to the effort as well. However, the result agrees well with Mensah (2019) who found that the effort expectancy and internet trust do not have an important impact on the intention of the government's internet of Chinese students as well as the study of Taylor and Strutoon (2010); Choi et al. (2011); Chaouali et al. (2016) who found that from the use of electronic commerce and mobile banking, the effort expectancy does not have the most important impact on the intention of electronic system use since the users find the performance of the system more important. Moreover, from the statistical analysis of this research, it was found that there is no positive support for the intention of D-Ticket which can be explained that the increase or decrease in the intention of D-Ticket system use does not depend on the simplicity of the system but other parameters thus with the increase in effort expectancy including the difficulty in the system use, the ticket reservation steps, and the well-explained guidelines does not increase the intention of the D-Ticket system use.

#### ***The Relationships Between Social Influences and the Intention of D-Ticket System Use***

The result shows that there is no significant interval of 0.05 which disagrees with hypothesis 9 that said social influences have a positive impact on the intention of D-Ticket system use while the result from hypothesis test agrees well with Naito et al. (2014) who found that the intention in system use of the internet users of biometric in electronic store is not from the influences of the surroundings or the media. Also, they do not find the application used to be more in trend than non-users. Furthermore, the result also agrees well with Wong et al. (2015); Salim (2012); Awwad and Al-Majali (2015) who proposed that social influences do not have a significant effect on service behaviors because other things that other people found more important do not affect the service due to the less impact of external parameters in comparison to internal parameters of the products including the usefulness and user-friendliness. Finally, after the statistical analysis of this study, the result shows that there is no positive supporting explanation of the hypothesis on the intention of D-Ticket system use which can be explained with the advice from the external members especially the chief executive or CEO e.g., the railway Governor, Minister of Transportation, the Prime Minister or the call center does not affect the consideration of using D-Ticket system.

### ***The Relationships Between Perceived Usefulness on the Intention of D-Ticket System Use***

The result shows that the perceived usefulness has an impact on the perceived switching value of D-Ticket system which agrees well with Pender (1996) who found that the recognition of benefits is a trust level of an individual to gain some benefits from one behavior or the trust level of a person who gains a positive benefit from their own action including food delivery application and products and service purchasing in which the perceived useful has both direct and indirect impacts on the intention of the use of that technology. Musyaffi et al. (2021) found that the benefits gained are an evaluation of the trust level of technology users who recognize that the system can be improved. The perceived usefulness is the most important indicator of services as users tend to adopt information systems because they see the features and usability of information systems.

### ***The Relationships Between Perceived Switching Values on the Intention of D-Ticket System Use***

The result shows that there is no significant interval of 0.05 which disagrees with hypothesis 11 that the perceived switching values have a negative impact on the intention of D-Ticket system use and the study of Mannan et al. (2017) who found that the perceived switching cost has a relationship with the intention of system use which if the perceived switching cost is low, the intention in using the old system will be longer. Moreover, the hypothesis test agrees well with Ting (2014) who found no relation between perceived switching cost and the level of purchase intention of the customers. However, the neutral satisfaction level customers show a positive and important switching cost and the purchase intention indicates that the organization should not aim for setting the switching cost to maintain the customers but should aim for maintaining the satisfaction of customers. Additionally, the statistical analysis from this work found no positive supporting hypothesis on the influences of perceived switching cost on the intention of D-Ticket system use which can be explained that transitioning from offline to online ticketing changes the cost of the customers including learning cost increases from the internet payment and smartphones yet these things do not affect the intention of D-Ticket system use.

### ***The Relationships Between Risks on the Intention of D-Ticket System Use***

The hypothesis test indicates that the risks and the intention of D-Ticket use do not have a significant interval of 0.05 which disagrees with hypothesis 12 that said risks have a negative impact on the intention of D-Ticket use and the study of Park and Kim (2014) who studied risks of online shopping and divided the risks acceptance into the risk of product delivery and payment. Dowling and Staelin (1994) found that the additional risk is the quality of products and the return of products/money from the purchase, the unsafe payment method is one of the components of risk acceptance. However, it agrees well with Kim and Koo (2016) who found that trust and risk influence each other but risks do not affect the intention of the transaction and Al-Saedi et al (2020) who found that risks do not affect the intention of mobile banking. Additionally, from the statistical result, it was found that there is no supporting explanation for the hypothesis that said risks have a negative impact on the intention of D-Ticket use which can be explained that even though, the passengers concern about the technical issues regarding the use of D-Ticket e.g., seat reservation, payment and privacy etc. However, the concern does not affect the intention of D-Ticket system use which can be concluded that the impacts of these risks still are not high enough to change the minds of the customers in D-Ticket use.

### ***The Relationships Between Trust on the Intention of D-Ticket System Use***

The hypothesis test indicates that trust and the intention of D-Ticket use do not have a significant interval of 0.05 which disagrees with hypothesis 13 that said trust has a positive impact on the intention of D-Ticket use. However, it agrees well with Mensah (2019) who found that effort expectancy and trust in the Internet are not important parameters for the intention of using electronic government of college students in China as well as Minarti and Segoro (2014) who found that brand trust does not have a significant impact on the intention of mobile phones use of the customers. Additionally, the statistical result found no support to the hypothesis about the positive influences of trust and the intention of D-Ticket system use which can be explained that the customers trust SRT or D-Ticket system. However, trust does not affect the use of D-Ticket since these people may find other parameters than trust also influencing the intention of D-Ticket system use.

### ***The Relationships Between Education Level on Perceived Usefulness***

The result shows that there is no significant interval of 0.05 which disagrees with hypothesis 14 that said education level shows a positive on the perceived usefulness and disagrees with Tavittyanan et al. (2022) who found that education level influences the perceived usefulness of hotel technology and customers with bachelor's degree or higher have more perceived usefulness of hotel technology significantly. However, it agrees well with van Dijk et al. (2008) who found that social and population demographics e.g., gender, age, social status, and education level do not have a significant effect on the perceived usefulness of internet use of the Netherlands government. Additionally, the statistical result found no support for hypothesis 14 which can be explained by that the perceived usefulness is beyond the learning under the curriculum thus the education level does not have any impact.

### ***The Relationships Between Education Level on the Perceived Switching Value***

The result shows that the education level of each sample group has an impact on the perceived switching value which agrees well with Kiser (2002) who found that population data is an important parameter used in the explanation of the relations of money saving time in which the potential in the change of household banking accounts with higher education levels and incomes is higher than of those with lower.

### ***The Relationships Between Education Level on D-Ticket System Use***

The result shows that there is no significant interval of 0.05 which disagrees with hypothesis 16 that said education system has a positive impact on D-Ticket system use which disagrees with Gumussoy et al. (2007) who found that education levels determine the behavior intention in the system use, the perceived convenient and usefulness of the system. However, it also agrees well with Sandrine (2009) who found that the population demographic e.g., gender, race, status, and education level does not affect the intention of Internet banking use [3. Furthermore, the statistical result indicates that there is no positive support for hypothesis 16 which can be explained that education levels have no significant impact on the intention of D-Ticket use. However, it co-influences the perceived switching values cost which affects the intention of D-Ticket use, and the education level lower than Bachelor's degree co-influences with the trust of D-Ticket system.

### CONCLUSION

This thesis studies the parameters influencing the intention of electronic ticket acquisition of passengers which is quantitative research via surveys from the data collecting of electronic questionnaires from social media platforms e.g., Line and Facebook. The unified theory of acceptance and usage of technology: UTAUT is modified and applied in this study with additional studied parameters including digital readiness and switching cost to the hypothesis test. The sample group is train passengers who have never purchased the tickets online via the website and D-Ticket application with the qualified sample group of 208 people used in the analysis. The population demographic result shows that 52.88% of the sample group is female, ages ranging between 31-40 is 37.98%, ages close to 41-50 is 34.13%, bachelor's degree or equal is 75.96%, public servants/government agents/state enterprisers is 36.06% (majority), cooperate, workers, is 34.13% and the average monthly income is 15,000-30,000 Baht is 54.92%. Furthermore, the statistical result found parameters that influence the intention of D-Ticket system use are the digital ecosystems and cultures and the effort expectancy has a direct effect on the intention of D-Ticket use as well. Moreover, responders have perceived switching and time costs as well as the service convenience. Lastly, the covariant analysis found that education level influences the intention of system use differently.

### ACKNOWLEDGMENT

The author would like to acknowledge the support from the State Railway of Thailand grant, The board members of the Department of Information Technology for the education opportunity, and the advisors as well as people who were involved in the complement of this thesis whom I did not mention.

### REFERENCES

- Al-Saedi, K., Al-Emran, M., Ramayah, T., & Abusham, E.E. (2020). Developing a general extended UTAUT model for M-payment adoption. *Technology in Society*, 62, 101293. <https://doi.org/10.1016/j.techsoc.2020.101293>
- Alshammari, S. H., Ali, M. B., & Rosli, M. S. (2016). The Influence of Technical Support, Self Efficacy and Instructional Design on the Usage and Acceptance of LMS: A Comprehensive Review. *Turkish Online Journal of Educational Technology*, 15(2), 116-125.
- Aishah, S. M., & Kassim, S. (2019). Examining the relationship between UTAUT construct, technology awareness, financial cost and e-payment adoption among microfinance clients in Malaysia. In *Proceedings of the 1st Aceh Global Conference (AGC 2018)* (pp. 351-357). Atlantis Press. <https://doi.org/10.2991/agc-18.2019.56>
- Ashari Nasution, R., Arnita, D., & Fatimah Azzahra, D. (2021). Digital Readiness and Acceptance of Mobile Advertising. *Australasian Marketing Journal*, 29(1), 95-103. <https://doi.org/10.1177/1839334921998555>
- Awwad, M. S., & Al-Majali, S. (2015). Electronic library services acceptance and use. *The Electronic Library*, 33(6), 1100-1120. <https://doi.org/10.1108/EL-03-2014-0057>
- Cetindamar Kozanoglu, D. & Abedin, B. (2021). Understanding the role of employees in digital transformation: conceptualization of digital literacy of employees as a multi-dimensional organizational affordance. *Journal of Enterprise Information Management*, 34(6), 1649-1672. <https://doi.org/10.1108/JEIM-01-2020-0010>
- Chaouali, W., Yahia, I. B., & Souiden, N. (2016). The interplay of counter-conformity motivation, social influence, and trust in customers' intention to adopt Internet banking services: The case of an emerging country. *Journal of Retailing and Consumer Services*, 28, 209-218. <https://doi.org/10.1016/j.jretconser.2015.10.007>
- Choi, H., Kim, Y., & Kim, J. (2011). Driving factors of post adoption behavior in mobile data services. *Journal of Business Research*, 64(11), 1212-1217. <https://doi.org/10.1016/j.jbusres.2011.06.025>
- Dowling, G. R., & Staelin, R. (1994). A Model of Perceived Risk and Intended Risk Handling Activity. *Journal of Consumer Research*, 21(1), 119-134.
- Gumussoy, C. A., Calisir, F., & Bayram, A. (2007). Understanding the behavioral intention to use ERP systems: An extended technology acceptance model. In *IEEE International Conference on Industrial Engineering and Engineering Management, 2007 IEEE International Conference on Industrial Engineering and Engineering Management (2024-2028)*. IEEE. <https://ieeexplore.ieee.org/document/4419547>
- Hammerton, M., Sibley, A., & Benson, T. (2021). Digital readiness within General Practice. Wessex, *Academic Health Science Network*. [https://wessexahsn.org.uk/img/projects/Digital%20Readiness%20Study%20Report\\_full\\_report-1612545101.pdf](https://wessexahsn.org.uk/img/projects/Digital%20Readiness%20Study%20Report_full_report-1612545101.pdf)
- Isabelle, B., & Sandrine, O. H. (2009). Towards an Understanding of Knowledge Management Systems - UTAUT Revisited. *15th Americas Conference on Information Systems, AMCIS 2009*, (5), 445.
- Jiang, L., Yang, Z., & Jun, M. (2013). Measuring consumer perception of online shopping convenience. *Journal of Service Management*, 24(2), 191-214. <https://doi.org/10.1108/09564231311323962>
- Kim, G., & Koo, H. (2016). The causal relationship between risk and trust in the online marketplace: A bidirectional perspective. *Computers in Human Behavior*, 55, 1020-1029. <https://doi.org/10.1016/j.chb.2015.11.005>

- Kiser, E. K. (2002). Predicting Household Switching Behavior and Switching Costs at Depository Institutions. *Review of Industrial Organization*, 20(4), 349-365. <http://www.jstor.org/stable/41799097>
- Mannan, M., Mohiuddin, M. F., Chowdhury, N., & Sarker, P. (2017). Customer satisfaction, switching intentions, perceived switching costs, and perceived alternative attractiveness in Bangladesh mobile telecommunications market. *South Asian Journal of Business Studies*, 6(2), 142-160. <https://doi.org/10.1108/SAJBS-06-2016-0049>
- Mensah, I. K. (2019). Factors Influencing the Intention of University Students to Adopt and Use E-Government Services: An Empirical Evidence in China. *SAGE Open*, 9(2). <https://doi.org/10.1177/2158244019855823>
- Minarti, S. N., & Segoro, W. (2014). The Influence of Customer Satisfaction, Switching Cost and Trusts in a Brand on Customer Loyalty – The Survey on Student as im3 Users in Depok, Indonesia. *Procedia - Social and Behavioral Sciences*, 143, 1015-1019. <https://doi.org/10.1016/j.sbspro.2014.07.546>
- Musyaffi, A. M., Mulyani, S., Suraida, I., & Sukmadilaga, C. (2021). Lack of Readiness of Digital Banking Channel Acceptance: Study on Tam 3 and Technology Readiness. *Academy of Strategic Management Journal*, 20(4S), 1-18.
- Nikou, S., De Reuver, M., & Mahboob Kanafi, M. (2022). Workplace literacy skills—how information and digital literacy affect adoption of digital technology. *Journal of Documentation*, 78(7), 371-391. <https://doi.org/10.1108/JD-12-2021-0241>
- Park, E., & Kim, K. J. (2014). An integrated adoption model of mobile cloud services: Exploration of key determinants and extension of technology acceptance model. *Journal of Telematics and Informatics*, 31(3), 376-385. <https://doi.org/10.1016/j.tele.2013.06.003>
- Pender, N. (1996). *Health Promotion in Nursing Practice (3rd ed.)*. Appleton and Lange.
- Rogers, E. M. (2003). *Diffusion of Innovation (5th ed.)*. Free Press.
- Schiffan, L. G., & Kanuk, L. L. (2009). *Consumer Behavior (10th ed.)*. Pearson Education
- Salim, B. (2012). An Application of UTAUT Model for Acceptance of Social Media in Egypt: A Statistical Study. *International Journal of Information Science*, 2(6), 92-105. <https://doi.org/10.5923/j.ijis.20120206.05>
- Soomro, M. A., Hizam-Hanafiah, M., & Abdullah, N. L. (2020). Digital readiness models: A systematic literature review. *Compusoft*, 9(3), 3596-3605.
- State Railway of Thailand. (n.d.). SRT Services. Retrieved November 30, 2022, from <https://www.railway.co.th>
- Susanto, A., Mahadika, P. R., Subiyakto, A., & Nuryasin. (2018). Analysis of Electronic Ticketing System Acceptance Using an Extended Unified Theory of Acceptance and Use of Technology (UTAUT). In *2018 6th International Conference on Cyber and IT Service Management (CITSM)* (pp. 1-5). IEEE. <https://ieeexplore.ieee.org/document/8674362>
- Tavitiyaman, P., Zhang, X., & Tsang, W. Y. (2022). How Tourists Perceive the Usefulness of Technology Adoption in Hotels: Interaction Effect of Past Experience and Education Level. *Journal of China Tourism Research*, 18(1), 64-87. <https://doi.org/10.1080/19388160.2020.1801546>
- Taylor, D. G., & Strutton, D. (2010). Has e-marketing come of age? Modeling historical influences on post-adoption era Internet consumer behaviors. *Journal of Business Research*, 63(9), 950-956. <https://doi.org/10.1016/j.jbusres.2009.01.018>
- Ting, S. C. (2014). The Relationship between Customers' Switching Cost and Repurchase Intention: The Moderating Role of Satisfaction. *Journal of Service Science and Management*, 7(4), 313-322. <https://doi.org/10.4236/jssm.2014.74028>
- Tiwari, P. & Tiwari, S. K. (2020). Integration of Technology Acceptance Model with Perceived Risk, Perceived Trust and Perceived Cost: Customer's Adoption of M-Banking. *International Journal on Emerging Technologies*, 11(2), 447-452.
- Van Dijk, J. A. G. M., Peters, O., & Ebbers, W. (2008). Explaining the acceptance and use of government Internet services: A multivariate analysis of 2006 survey data in the Netherlands. *Government Information Quarterly*, 25(3), 379-399. <https://doi.org/10.1016/j.giq.2007.09.006>
- Vitikko, J. (2023). Perceived switching costs in a social network site: case Facebook [Master's thesis, Lappeenranta-Lahti University of Technology LUT]. LUT University. <https://lutpub.lut.fi/handle/10024/165486>
- Wong, C. H., Tan, G. W. H., Loke, S -P., & Ooi, K. B. (2015). Adoption of mobile social networking sites for learning?. *Online Information Review*, 39(6), 762-778. <https://doi.org/10.1108/OIR-05-2015-0152>

## Fostering Fintech Adoption in Growing Economies: Opportunities, Challenges, and Strategies

Eldon Y. Li <sup>1</sup>  
Usama Zafar <sup>2,\*</sup>

\*Corresponding author

<sup>1</sup> Chair Professor, National Chung Cheng University, Chiayi, Taiwan, miseli@ccu.edu.tw

<sup>2</sup> Doctoral Student, National Chung Cheng University, Chiayi, Taiwan, usamazafar@alum.ccu.edu.tw

### ABSTRACT

Fintech adoption has become increasingly popular in many developing countries due to its potential to increase financial inclusion and promote economic growth. However, fostering fintech adoption in growing economies presents challenges, opportunities, and strategies that differ from those in developed countries. This systematic literature review aims to identify the current state of fintech adoption in growing economies, including the challenges and opportunities of fintech adoption and the strategies used to foster it. A comprehensive search of electronic databases, including Scopus and Web of Science, was conducted for relevant articles published between 2018 and 2023. The screening process identified 12 articles that were critically appraised to ensure the quality of their content. The findings suggest that although fintech adoption in growing economies presents unique challenges, such as lack of infrastructure and limited digital literacy, it also provides various opportunities to increase financial inclusion, promote economic growth, and improve overall financial services. The strategies for fostering fintech adoption in growing economies include developing supportive regulatory frameworks, building digital infrastructure, and improving digital literacy through education and awareness programs. This study contributes to a better understanding of the current development of fintech adoption in growing economies, provides insights for policymakers and practitioners, and highlights the need for further research in this area.

*Keywords:* Fintech Adoption, Financial Inclusion, Regulatory Environment, Growing Economies.

### INTRODUCTION

Financial technology (fintech) has transformed the financial sector, revolutionizing how financial services are delivered in many developed countries. Fintech adoption in these countries has provided consumers with convenient and cost-effective financial solutions, driving efficiency and innovation. However, adopting fintech in growing economies presents a distinct set of challenges and opportunities that differ from those encountered in developed countries. As developing countries strive for economic progress, many have recognized the potential benefits of fintech adoption in promoting financial inclusion and stimulating economic growth. Addressing the challenges associated with fintech adoption in growing economies is crucial to realizing these benefits fully (Feyen et al., 2021).

This research article presents a systematic literature review to examine the current state of fintech adoption in growing economies, focusing on the challenges, opportunities, and strategies involved. The study sheds light on the unique dynamics of fintech adoption in developing countries, particularly those experiencing rapid economic growth. By doing so, this research provides valuable insights and guidance for policymakers, regulators, and practitioners involved in fostering fintech adoption in growing economies.

Li and Li (2016) highlighted the information security challenges associated with adopting Fintech. They emphasized the need for robust security measures to protect sensitive data and maintain trust in financial transactions. The authors suggested that addressing these challenges requires a comprehensive approach involving technological solutions, regulatory frameworks, and user awareness. They proposed considering the importance of collaboration among financial institutions, technology providers, regulators, and consumers to ensure the safe and secure adoption of Fintech services in the digital era.

### LITERATURE REVIEW

According to Anthony-Orji et al. (2019), financial inclusion is a critical concern in developing countries where a considerable proportion of the population lacks access to formal financial services. The World Bank estimates that approximately 1.7 billion adults worldwide require access to such services. Fintech adoption represents a transformative opportunity to enhance financial inclusion by offering cost-effective and convenient financial services to the unbanked and underbanked populations. In fact, the World Bank projects that fintech has the potential to extend formal financial services to an additional 1.6 billion adults.

Alwi et al. (2019) focused on consumer acceptance and adoption of payment-type Fintech services from a Malaysian perspective. The study explored factors such as perceived usefulness, ease of use, trust, and awareness influencing consumers' intention to adopt Fintech services. The findings indicated that perceived usefulness and trust significantly impacted consumer



adoption. The study underscored the significance of enhancing consumers' perception of usefulness and trust in Fintech services to drive adoption rates.

According to Anifa et al. (2022), fintech adoption goes beyond financial inclusion as it has the potential to drive economic growth by providing access to finance for small and medium-sized enterprises (SMEs). In many developing economies, SMEs play a pivotal role in driving economic activity, yet they often need help securing financing from traditional banking institutions. Fintech platforms offer alternative financing sources for SMEs, which can stimulate economic growth and generate employment opportunities.

However, fintech adoption in growing economies faces significant challenges despite the potential benefits (Varma et al., 2022). One significant barrier is the need for robust digital infrastructure in many developing countries. Reliable internet connectivity and mobile networks are indispensable for the growth and scalability of fintech services. Additionally, limited digital literacy among the population poses a hurdle to the widespread adoption of fintech solutions. Other challenges include the need for more supportive regulatory frameworks, concerns regarding cybersecurity risks, and apprehensions regarding data privacy.

Al Nawayseh (2020) examined the factors influencing customers' choice of Fintech applications during the COVID-19 pandemic and beyond. The study investigated the impact of various factors on Fintech adoption, including trust, perceived risk, convenience, and financial literacy. The findings highlighted the importance of these factors in shaping customers' decisions to adopt Fintech services. Understanding these factors aided in the design of effective strategies to promote Fintech adoption and usage.

To foster fintech adoption in growing economies, policymakers and regulators must develop regulatory frameworks that encourage innovation and ensure consumer protection (Mahmud et al., 2023). Investment in digital infrastructure, including the expansion of reliable internet connectivity and mobile networks, is paramount to support the broad-based adoption of fintech services. Equally important is improving digital literacy through education and awareness programs, empowering individuals to engage with fintech solutions effectively. Fintech providers should prioritize the development of products and services tailored to the needs of the unbanked and underbanked populations. Exploring alternative data sources and innovative credit scoring models can help extend credit to individuals currently excluded from the formal financial system.

Hu et al. (2019) empirically examined the adoption intention of Fintech services among bank users. The study extended the Technology Acceptance Model (TAM) to incorporate additional factors such as perceived risk and perceived enjoyment. The results revealed that perceived usefulness, ease of use, and enjoyment positively influenced users' intention to adopt Fintech services. Moreover, perceived risk negatively affected adoption intention. The study suggested that addressing perceived risk and emphasizing the benefits and enjoyment of Fintech services could foster adoption among bank users.

Hence, fostering fintech adoption in growing economies requires a comprehensive understanding of the unique challenges, opportunities, and strategies involved. This systematic literature review contributes to this understanding by examining the current state of fintech adoption in developing countries. The potential benefits of fintech adoption in these economies, including enhanced financial inclusion and economic growth, are substantial. Addressing the challenges associated with fintech adoption in growing economies is crucial for realizing these benefits. Further research is warranted to gain deeper insights into the dynamics of fintech adoption in growing economies and to develop effective strategies for fostering its adoption.

## MATERIAL AND METHODS

### The PRISMA Guidelines

The PRISMA (Preferred Reporting Items for Systematic Review and Meta-Analysis) Guidelines provide researchers with a standardized framework for reporting systematic reviews and meta-analyses. These guidelines enhance the transparency, clarity, and completeness of research studies in these fields. By following the PRISMA Guidelines, researchers ensure a rigorous and consistent approach to their work, covering research questions, study design, search strategy, data extraction, study quality assessment, and result interpretation. Adhering to the PRISMA Guidelines promotes credibility, and reproducibility, and facilitates the evaluation and comparison of studies within specific fields. Ultimately, the PRISMA Guidelines contribute to evidence-based decision-making and the advancement of knowledge in various research disciplines (Shamseer et al., 2015).

### Search Strategy

This paper used a systematic literature review to examine various growing economies like India, Pakistan, Nepal, Bangladesh, and some African countries. To conduct this systematic literature review, a comprehensive search of electronic databases was conducted to identify relevant articles published between 2018 and 2023. The search was performed using Scopus and Web of Science for relevant articles published between 2018 and 2023. A combination of keywords was used to identify relevant studies, including those recommended by experts and previous research. The search strings were extracted from these keywords to answer the research questions using special functions like Boolean operator (restricted to AND and OR) on Scopus and Web of Science (WOS) databases. The search string used in Scopus was TITLE-ABS-KEY(( fintech OR "Fintech

adoption" OR "Fintech" OR "FinTech" OR "Financial Technology" OR "Financial Services" OR "Fintech Readiness" OR "Financial Innovation" OR "Technology Readiness" OR "Financial Regulations" OR "Financial Technologies" OR "Financial Technology (Fintech)" OR "Fin-Tech") AND ("financial inclusion" OR inclusive Finance")), while the string used in WOS was TS=(( fintech OR "financial technology" OR "Fintech" OR "FinTech adoption" OR "Financial Technology" OR "Financial Services" OR "Technological Readiness" OR "Fintech Innovation" OR "Digital Technologies" OR "Financial Technologies" OR "Financial Technology (Fintech)" OR "Fin-Tech") AND ("financial inclusion\*" OR "Inclusive Finance")).

### Selection Criteria

The literature review was conducted using the PRISMA methodology. These searches yielded a total of 996 articles from the two selected databases, with 573 articles from Scopus and 423 articles from Web of Science (WOS). Note that there are many duplicate articles in this search output. The review process followed the PRISMA guidelines, which involved assessing the abstracts and full texts of the identified articles. This systematic approach ensures transparency, replicability, and accuracy in the literature review process, enabling a comprehensive analysis of the available research.

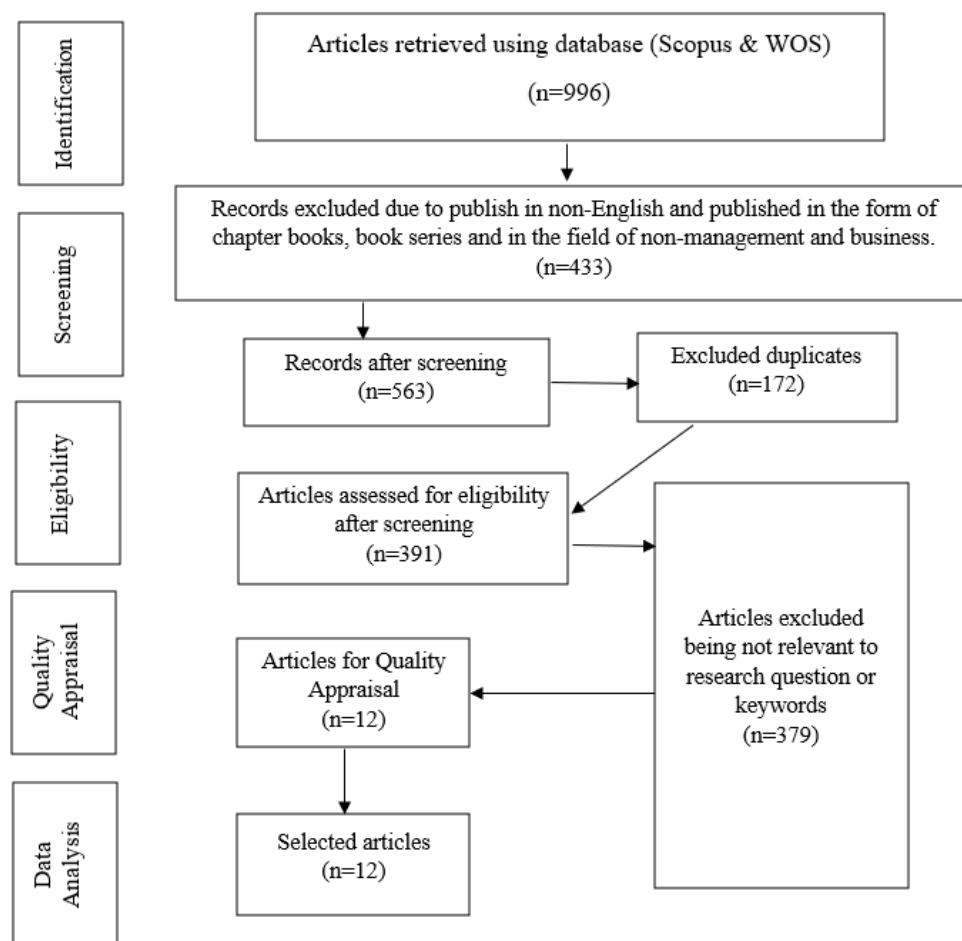

Figure 1: Literature selection using the PRISMA methodology

The review process involved screening the titles and abstracts for relevance and eligibility. After selecting 563 articles for screening, the next step was determining their eligibility. This involved reading the title and abstract of each article to determine if it met the inclusion and exclusion criteria. Duplicates were removed, leaving 391 articles for further screening. The PRISMA process yielded 12 articles for detailed analysis, as shown in Table 1. These articles underwent a critical appraisal process to ensure the quality of their content. The critical appraisal process is important in systematic reviews to assess the trustworthiness, value, and relevance of research in a particular context. It helps to rank the quality of papers as moderate and high and ensure the reliability of the study findings. These articles that met the inclusion criteria were read in full, and their key findings and conclusions were extracted. The extracted data were then analyzed to identify the opportunities, challenges, and strategies for fostering fintech adoption in growing economies. Table 2 reveals the quality aspects of each article.

Table 1: Articles included in this review

No.	Year	Authors	Title	Journal	Debut Year
1	2018	Ku-Mahamud, K.R., Bakar, N.A.A., Omar, M.	Blockchain, cryptocurrency and Fintech market growth in Malaysia	<i>Journal of Advanced Research in Dynamical and Control Systems</i>	2009
2	2018	Kang, J.	Mobile payment in Fintech environment: trends, security challenges, and services	<i>Human-centric Computing and Information Sciences</i>	2011
3	2019	Hu, Z., Ding, S., Li, S., Chen, L., & Yang, S.	Adoption Intention of Fintech Services for Bank Users: An Empirical Examination with an Extended Technology Acceptance Model	<i>Symmetry</i>	2009
4	2019	Alwi, S., Salleh, M.N.M., Razak, S.E.A., & Naim, N.	Consumer acceptance and adoption towards payment-type fintech services from Malaysian perspective	<i>International Journal of Advanced Science and Technology</i>	2008
5	2020	Ryu, H.-S., & Ko, K. S.	Sustainable Development of Fintech: Focused on Uncertainty and Perceived Quality Issues	<i>Sustainability</i>	2009
6	2020	Al nawayseh, M. K.	FinTech in COVID-19 and Beyond: What Factors Are Affecting Customers' Choice of FinTech Applications?	<i>Journal of Open Innovation: Technology, Market, and Complexity</i>	2015
7	2021	Utami, A.F., Ekaputra, I.A., Japutra, A.	Adoption of FinTech Products: A Systematic Literature Review	<i>Journal of Creative Communications</i>	2009
8	2021	Xie, J., Ye, L., Huang, W., & Ye, M.	Understanding FinTech Platform Adoption: Impacts of Perceived Value and Perceived Risk	<i>Journal of Theoretical and Applied Electronic Commerce Research</i>	2006
9	2022	Yang, T., Zhang, X.	FinTech adoption and financial inclusion: Evidence from household consumption in China	<i>Journal of Banking &amp; Finance</i>	1977
10	2022	Widayani, A., Fiernaningsih, N., Herijanto, P.	Barriers to digital payment adoption: micro, small and medium enterprises	<i>Management and Marketing</i>	2006
11	2023	Irimia-Diéguez, A., Velicia-Martín, F., Aguayo-Camacho, M.	Predicting Fintech Innovation Adoption: the Mediator Role of Social Norms and Attitudes	<i>Financial Innovation</i>	2015
12	2023	Kowalewski, O., Pisany, P.	The rise of fintech: A cross-country perspective	<i>Technovation</i>	1981

Table 2: Summary of Articles' models included in this review

Study	Model/Methodology	Opportunities	Challenges	Strategies
1	<ul style="list-style-type: none"> <li>The quantitative approach was used in this study to examine the factors influencing the growth of blockchain, cryptocurrency.</li> <li>A questionnaire was used.</li> </ul>	<ul style="list-style-type: none"> <li>Growing Fintech market in Malaysia</li> </ul>	<ul style="list-style-type: none"> <li>Regulatory uncertainties</li> </ul>	<ul style="list-style-type: none"> <li>Establishing clear regulatory frameworks</li> </ul>
2		<ul style="list-style-type: none"> <li>Increasing trends in mobile adoption</li> </ul>	<ul style="list-style-type: none"> <li>Security concerns</li> </ul>	<ul style="list-style-type: none"> <li>Enhancing security measures in mobile payment services</li> </ul>
3		<ul style="list-style-type: none"> <li>Convenience</li> <li>Accessibility</li> <li>Financial inclusion</li> <li>Efficiency</li> <li>Cost savings</li> <li>Innovation</li> </ul>	<ul style="list-style-type: none"> <li>Security</li> <li>Digital literacy</li> <li>Resistance</li> <li>Regulation</li> <li>Infrastructure</li> </ul>	<ul style="list-style-type: none"> <li>Security</li> <li>Digital literacy</li> <li>Resistance</li> <li>Regulation</li> <li>Infrastructure</li> </ul>

<p>4</p>		<ul style="list-style-type: none"> <li>• Consumer acceptance of payment-type Fintech services</li> </ul>	<ul style="list-style-type: none"> <li>• Lack of trust and security concerns</li> </ul>	<ul style="list-style-type: none"> <li>• Building trust through secure and reliable services</li> </ul>
<p>5</p>		<ul style="list-style-type: none"> <li>• Financial inclusion</li> <li>• Improved customer experience</li> <li>• Enhanced efficiency</li> <li>• Access to new markets</li> <li>• Innovation and creativity</li> </ul>	<ul style="list-style-type: none"> <li>• Uncertainty</li> <li>• Perceived quality issues</li> <li>• Regulatory compliance</li> <li>• Cybersecurity risks</li> <li>• Adoption barriers</li> </ul>	<ul style="list-style-type: none"> <li>• Risk management</li> <li>• Quality assurance</li> <li>• Regulatory compliance</li> <li>• Customer Education</li> <li>• Collaboration and partnerships</li> <li>• Technology monitoring and evaluation</li> </ul>

<p>6</p>	<pre> graph LR     SI((Social Influence [+])) -- 3.018 --&gt; UI((Usage Intention [+]))     B((Benefits [+])) -- 15.827 --&gt; UI     R((Risks [+])) -- 0.534 --&gt; UI     T((Trust [+])) -- 4.947 --&gt; UI     R -- 7.788 --&gt; T     </pre>	<ul style="list-style-type: none"> <li>• Digital transformation</li> <li>• Contactless services</li> <li>• Enhanced customer experience</li> <li>• Market expansion</li> <li>• Technological innovation</li> </ul>	<ul style="list-style-type: none"> <li>• Privacy Trust and security</li> <li>• Awareness and understanding</li> <li>• Regulatory compliance</li> <li>• Infrastructure limitations</li> <li>• Resistance to change</li> </ul>	<ul style="list-style-type: none"> <li>• Building trust</li> <li>• Increasing awareness</li> <li>• Collaboration</li> <li>• User-friendly interfaces</li> <li>• Regulatory compliance</li> <li>• Customer support</li> </ul>
<p>7</p>	<pre> graph LR     subgraph Innovator         IIF[Innovator's internal focus 1. Product orientation and innovation 2. Investment in R&amp;D and technology 3. Continuous learning]         IEF[Innovator's external focus 1. Competitive action 2. Market orientation and innovation 3. Strategic cooperation]     end     subgraph Adopter         AIF[Adopter's internal factors 1. Perception of the product characteristics (e.g., perceived ease of use, perceived usefulness, perceived safety, perceived privacy, perceived relative advantage and superiority) 2. Individual or organisational characteristics (e.g., motivation, beliefs, habit, value, technology competency and experience)]         AEF[Adopter's external factors 1. Policies and regulations 2. Sociocultural aspects (e.g., culture and social contagion)]     end     IIF --&gt; FTA[FinTech Product Adoption]     IEF --&gt; FTA     AIF --&gt; FTA     AEF --&gt; FTA     </pre>	<ul style="list-style-type: none"> <li>• Financial inclusion</li> <li>• Cost savings</li> <li>• Convenience</li> <li>• Enhanced access to financial services</li> <li>• Innovation</li> </ul>	<ul style="list-style-type: none"> <li>• Security and privacy concerns</li> <li>• Lack of trust</li> <li>• Limited digital literacy</li> <li>• Regulatory hurdles</li> <li>• Resistance to change</li> </ul>	<ul style="list-style-type: none"> <li>• Education and awareness programs</li> <li>• Enhancing security measures</li> <li>• Building trust through transparency</li> <li>• Collaboration with traditional financial institutions</li> <li>• Developing user-friendly interfaces</li> </ul>

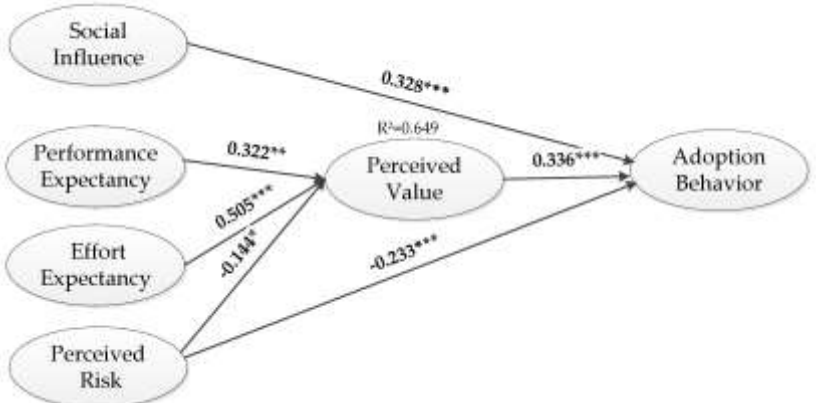
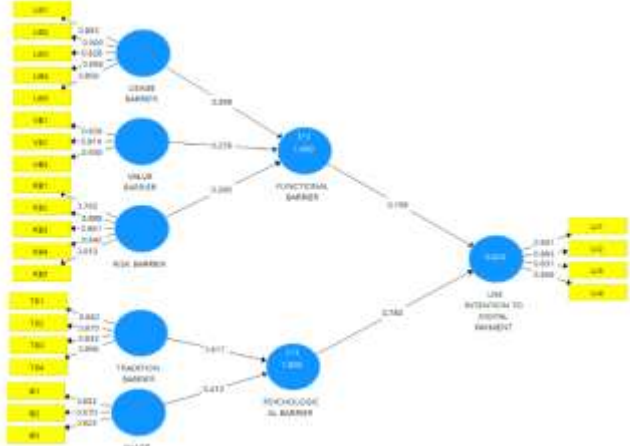
<p>8</p>		<ul style="list-style-type: none"> <li>• Enhanced financial services</li> <li>• Access to innovative solutions</li> <li>• Increased convenience</li> <li>• Improved efficiency</li> <li>• Potential cost savings</li> </ul>	<ul style="list-style-type: none"> <li>• Security and privacy concerns</li> <li>• Lack of trust in new technologies</li> <li>• Complexity of FinTech platforms</li> <li>• Limited awareness and understanding</li> <li>• Resistance to change</li> </ul>	<ul style="list-style-type: none"> <li>• Communicating perceived value</li> <li>• Addressing perceived risks</li> <li>• Building trust through transparency</li> <li>• Enhancing user experience</li> <li>• Providing user-friendly interfaces</li> </ul>
<p>9</p>	<p>Literature Review</p>	<ul style="list-style-type: none"> <li>• Increased access to financial services</li> <li>• Expansion of financial inclusion</li> <li>• Facilitation of financial transactions</li> <li>• Potential for economic empowerment</li> <li>• Improved financial decision-making</li> </ul>	<ul style="list-style-type: none"> <li>• Awareness</li> <li>• Access inequality</li> <li>• Trust</li> <li>• Regulations</li> </ul>	<ul style="list-style-type: none"> <li>• Education</li> <li>• Connectivity</li> <li>• Security</li> <li>• Collaboration</li> </ul>
<p>10</p>		<ul style="list-style-type: none"> <li>• Streamlined Payments</li> </ul>	<ul style="list-style-type: none"> <li>• Lack of digital infrastructure and awareness</li> </ul>	<ul style="list-style-type: none"> <li>• - Building digital infrastructure and providing education</li> </ul>

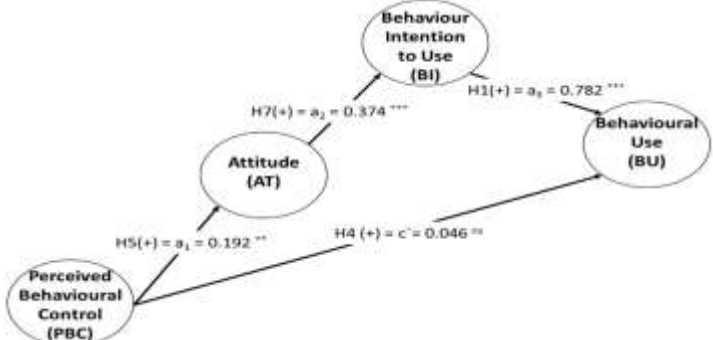
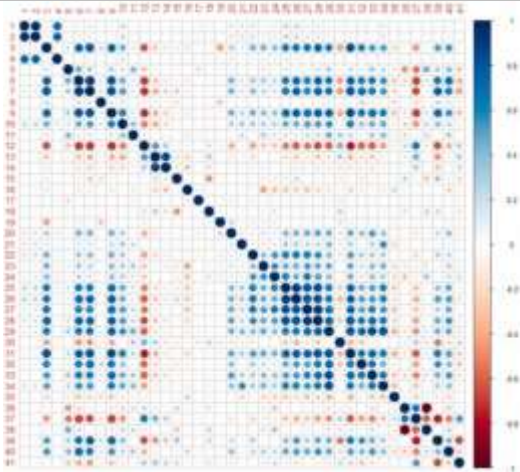

<p>11</p>		<ul style="list-style-type: none"> <li>• Innovation Adoption</li> </ul>	<ul style="list-style-type: none"> <li>• Resistance to change and lack of awareness</li> </ul>	<ul style="list-style-type: none"> <li>• - Promoting positive social norms and attitudes</li> </ul>
<p>12</p>	 <p>Correlation Matrix</p>	<ul style="list-style-type: none"> <li>• Innovation</li> <li>• Financial inclusion</li> <li>• Economic growth</li> <li>• Efficiency</li> </ul>	<ul style="list-style-type: none"> <li>• Regulatory concerns</li> <li>• Cybersecurity risks</li> <li>• Disruption to traditional financial institutions</li> <li>• Data privacy</li> </ul>	<ul style="list-style-type: none"> <li>• Regulatory frameworks</li> <li>• Collaboration between firms and institutions</li> <li>• Investment in cybersecurity measures</li> <li>• Consumer education and awareness</li> </ul>

## CONCLUSION AND DISCUSSIONS

The reviewed studies provide valuable insights into various aspects of Fintech adoption, growth, and user behavior. The results highlight the increasing acceptance and utilization of Fintech services, the importance of addressing security and quality concerns, and the role of factors such as perceived value, trust, convenience, and the customer experience in driving Fintech adoption. Further research in this field can continue to explore emerging technologies, user preferences, regulatory frameworks, and the impact of Fintech on financial inclusion and economic development. Figure 2 highlights the opportunities, challenges, and strategies for fostering fintech adoption in growing economies. The discussion of each aspect follows.

### Opportunities

Fintech adoption in growing economies presents unique opportunities to enhance financial inclusion and drive socioeconomic growth. One significant opportunity lies in extending formal financial services to the unbanked and underbanked populations. Fintech solutions have the potential to bridge the gap by providing access to banking services, promoting financial literacy, and enabling secure and convenient transactions. This can lead to significant socioeconomic benefits such as poverty reduction, economic empowerment, and improved livelihoods for individuals and communities.

Additionally, fintech adoption can stimulate economic growth by facilitating access to finance for small and medium-sized enterprises (SMEs). SMEs play a vital role in driving economic activity in many developing economies, but they often need help securing financing from traditional banking institutions. Fintech platforms offer alternative financing sources, enabling SMEs to access capital more efficiently and expand their operations. This can lead to increased entrepreneurship, job creation, and overall economic development.

### Challenges

While there are significant opportunities, fintech adoption in growing economies may also face challenges that need to be addressed. One major challenge is the need for robust digital infrastructure in many developing countries. Limited access to reliable internet connectivity and mobile networks can hinder the adoption and usage of fintech solutions. To overcome this challenge, policymakers and stakeholders must prioritize investment in digital infrastructure. Expanding reliable internet connectivity and improving mobile network coverage, particularly in rural areas with limited access, will enable wider adoption and usage of fintech services.

Another challenge is the limited digital literacy among the population. Many individuals in growing economies may need more skills and knowledge to engage with fintech solutions effectively. This poses a barrier to the adoption and usage of fintech services. Education and awareness programs should be developed to address this challenge to improve digital literacy. These programs can help individuals understand the benefits and functionalities of fintech solutions and equip them with the skills needed to navigate digital platforms.

### Strategies

To foster fintech adoption in growing economies, several strategies can be implemented. Developing supportive regulatory frameworks is crucial to create an enabling environment for fintech innovation while ensuring consumer protection. Policymakers and regulators must strike a balance between fostering innovation and managing risks associated with fintech services. Collaborating with industry stakeholders can facilitate the development of regulations that accommodate the evolving fintech landscape and promote responsible fintech practices.

Moreover, fintech providers should focus on developing products and services tailored to the needs of the unbanked and underbanked populations. This may involve leveraging alternative data sources and innovative credit scoring models to extend credit to individuals who are currently excluded from the formal financial system. By offering solutions that address specific financial needs and preferences, fintech providers can encourage adoption and usage among underserved populations.

In addition, enhancing digital literacy through education and awareness programs is crucial to overcome the barriers to fintech adoption. These programs should aim to improve individuals' understanding of fintech solutions, their benefits, and how to utilize them effectively. By equipping individuals with the necessary digital skills and knowledge, they can confidently engage with fintech platforms and make informed financial decisions.

Finally, the systematic literature review followed a rigorous and transparent process to identify relevant articles, assess their quality, and synthesize the findings. The review provides a comprehensive and up-to-date overview of the current state of fintech adoption in growing economies, including the challenges, opportunities, and strategies for fostering fintech adoption. The findings of this study can inform policymakers, regulators, and practitioners on how to promote fintech adoption in developing countries.

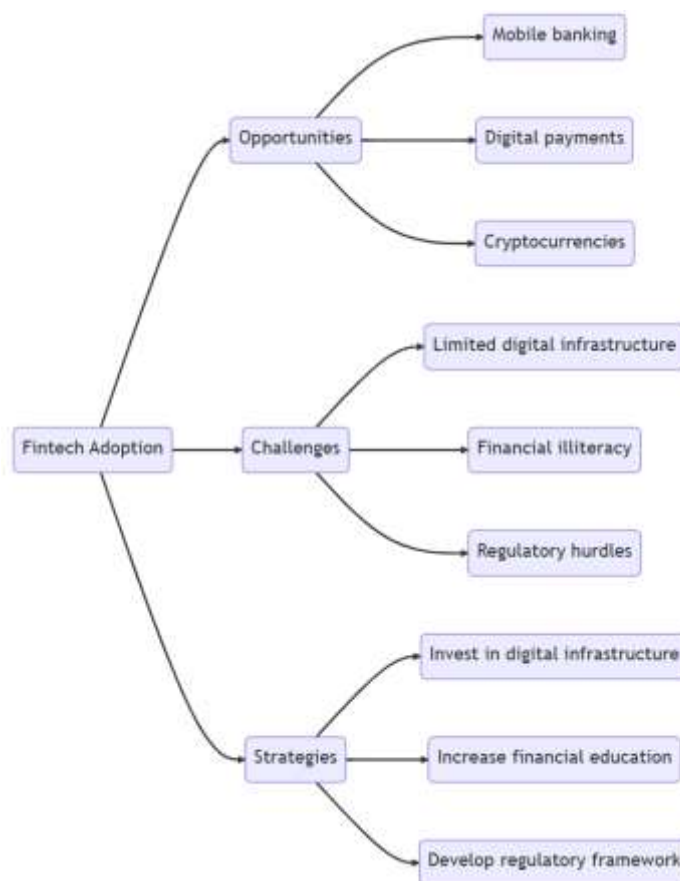

Figure 2: Fintech Adoption Opportunities, Challenges, and Strategies

### Future Research

Several key areas warrant further research to enhance our understanding of fintech adoption in growing economies. First, exploring the contextual factors and regional dynamics influencing fintech adoption would provide valuable insights. Investigating the impact of cultural norms, regulatory environments, and economic conditions on adopting and using fintech services can shed light on the challenges and opportunities faced by different countries or regions. This would enable the development of more targeted strategies and interventions to foster fintech adoption.

Another important avenue for future research lies in assessing the long-term impacts of fintech adoption on financial inclusion and economic growth in growing economies. Longitudinal studies can help evaluate the effectiveness of fintech solutions in extending formal financial services to unbanked and underbanked populations. Such research can also examine the contributions of fintech adoption to poverty reduction, economic empowerment, and improved livelihoods. Policymakers and stakeholders can make more informed decisions by analyzing the sustainable and inclusive development outcomes of fintech adoption.

Furthermore, exploring the implications of emerging technologies and future trends on fintech adoption in growing economies is crucial. Research should delve into the potential benefits and risks associated with technologies such as blockchain, artificial intelligence, and big data analytics within the fintech ecosystem. Understanding the impact of these technologies on financial services, customer behavior, and industry dynamics can guide the development of appropriate strategies and policies to navigate the evolving fintech landscape.

User experience and trust are also important areas for future investigation. Research should focus on understanding the role of user interface design, privacy, and security concerns, and trust-building mechanisms in shaping user perceptions and intentions towards fintech services. By identifying the factors influencing user trust and satisfaction, researchers can provide valuable insights for enhancing the design and delivery of fintech products and services. Finally, future research should examine the effectiveness of policy and regulatory frameworks in fostering fintech adoption in growing economies. Evaluating the impact of regulatory sandboxes, licensing requirements, and consumer protection measures on fintech innovation and consumer trust can offer valuable insights. Comparative studies across different regulatory approaches can further explain how to strike an optimal balance between promoting innovation and mitigating risks within fintech ecosystems. By addressing these research areas, future studies can advance our knowledge of fintech adoption in growing economies, inform evidence-based policymaking, and support fintech ecosystems' sustainable and inclusive development.

### ACKNOWLEDGEMENT

This research was partially supported by the Ministry of Science and Technology in Taiwan (Grant No. 111-2410-H-194-029-MY2 and 112-2410-H-194-029-MY3).

### REFERENCES

- Al Nawayseh, M. K. (2020). Fintech in COVID-19 and beyond: what factors affect customers' choice of fintech applications?. *Journal of Open Innovation: Technology, Market, and Complexity*, 6(4), 153.
- Alwi, S., Salleh, M. N. M., Razak, S. A., & Naim, N. (2019). Consumer acceptance and adoption towards payment-type fintech services from Malaysian perspective. *International Journal of Advanced Science and Technology*, 28(15), 216-231.
- Anthony-Orji, O. I., Orji, A., Ogbuabor, J. E., & Nwosu, E. O. (2019). Do financial stability and institutional quality have impact on financial inclusion in developing economies? A new evidence from Nigeria. *International Journal of Sustainable Economy*, 11(1), 18-40.
- Anifa, M., Ramakrishnan, S., Joghee, S., Kabiraj, S., & Bishnoi, M. M. (2022). Fintech Innovations in the Financial Service Industry. *Journal of Risk and Financial Management*, 15(7), 287.
- Feyen, E., Frost, J., Gambacorta, L., Natarajan, H., & Saal, M. (2021). Fintech and the digital transformation of financial services: implications for market structure and public policy. *BIS Papers*.
- Hu, Z., Ding, S., Li, S., Chen, L., & Yang, S. (2019). Adoption intention of fintech services for bank users: An empirical examination with an extended technology acceptance model. *Symmetry*, 11(3), 340.
- Irimia-Diéguez, A., Velicia-Martín, F., & Aguayo-Camacho, M. (2023). Predicting FinTech innovation adoption: the mediator role of social norms and attitudes. *Financial Innovation*, 9(1), 1-23.
- Kang, J. (2018). Mobile payment in Fintech environment: trends, security challenges, and services. *Human-centric Computing and Information sciences*, 8(1), 1-16.
- Kowalewski, O., & Pisany, P. (2023). The rise of fintech: a cross-country perspective. *Technovation*, 122, 102642.
- Ku-Mahamud, K. R., Abu Bakar, N. A., & Omar, M. (2018). Blockchain, cryptocurrency and Fintech market growth in Malaysia. *Journal of Advance Research in Dynamical & Control Systems*, 10(14 SI), 2074-2082.
- Li, Eldon Y. and Li, Jong Peir, "Information Security Challenges in the New Era of Fintech" (2016). *ICEB 2016 Proceedings (Xiamen, China)*. 39. <https://aisel.aisnet.org/iceb2016/39>
- Ryu, H. S., & Ko, K. S. (2020). Sustainable development of Fintech: Focused on uncertainty and perceived quality issues. *Sustainability*, 12(18), 7669.
- Shamseer, L., Moher, D., Clarke, M., Ghersi, D., Liberati, A., Petticrew, M., ... & Stewart, L. A. (2015). Preferred reporting items for systematic review and meta-analysis protocols (PRISMA-P) 2015: elaboration and explanation. *Bmj*, 349.
- Utami, A. F., Ekaputra, I. A., & Japutra, A. (2021). Adoption of FinTech products: a systematic literature review. *Journal of Creative Communications*, 16(3), 233-248.
- Widayani, A., Fiernaningsih, N., & Herijanto, P. (2022). Barriers to digital payment adoption: micro, small and medium enterprises. *Management & Marketing*, 17(4), 528-542.
- Xie, J., Ye, L., Huang, W., & Ye, M. (2021). Understanding FinTech platform adoption: impacts of perceived value and perceived risk. *Journal of Theoretical and Applied Electronic Commerce Research*, 16(5), 1893-1911.
- Yang, Tong & Zhang, Xun, (2022). "FinTech adoption and financial inclusion: Evidence from household consumption in China," *Journal of Banking & Finance, Elsevier, vol. 145(C)*.

## **From Adoption to Adaptation: Bridging Digital Transformation and AI Integration in Contemporary SMEs**

Hsiang An Hu <sup>1</sup>  
Hsiao-Ting Tseng <sup>2,\*</sup>  
Jian Mou <sup>3,\*</sup>  
Jongki Kim <sup>4</sup>

\*Corresponding author

<sup>1</sup> National Central University, Taoyuan, Taiwan, tn00313445@gmail.com

<sup>2</sup> National Central University, Taoyuan, Taiwan, httseng@mgt.ncu.edu.tw

<sup>3</sup> Pusan National University, Busan, South Korea, jian.mou@pusan.ac.kr

<sup>4</sup> Pusan National University, Busan, South Korea, jkkim1@pusan.ac.kr

### **ABSTRACT**

In today's rapidly evolving business landscape with prevalent uncertainties, firms seek innovative strategies to remain competitive and sustainable. The ascent of digital transformation and artificial intelligence (AI) presents both opportunities and challenges, emphasizing swift adoption and adaptation. SMEs risk further losses by solely focusing on the advantages of new technologies without addressing organizational adaptability and culture. This strategy cannot simply be mirrored from larger enterprises. This study offers a two-phase exploration of the interplay between digital transformation and AI integration. The first phase, informed by literature and qualitative research, crafts a digital transformation strategy. The subsequent phase, through mixed-method case studies, assesses enterprise readiness for AI, resulting in a strategic model validated by industry practices, benefiting enterprise management and AI integration. This study highlights the critical linkage between digital transformation foundations and AI adoption readiness in SMEs, providing strategic insights based on a two-stage research approach.

*Keywords:* Digital transformation, Artificial intelligence, Readiness, Adoption, Adaptation

### **INTRODUCTION**

Economist Schumpeter (1939) said: "Economic development can only be achieved through creative innovation and change." In the contemporary business environment of rapid transformation and pervasive uncertainty, businesses are constantly striving to develop innovative strategies and approaches to maintain a competitive advantage and ensure sustainable growth.

From the perspective of sustainable business management, neither individuals nor organizations are only satisfied with the advantages and conveniences brought by the current digital transformation. Therefore, continuous growth is necessary. Since 2020, as artificial intelligence (AI) technologies anchored in big data have advanced, businesses in diverse sectors have increased their attention to the application of AI. For example, in the "Sustainable Development Report for Fiscal Year 2021" (2021) released by Taiwan Semiconductor Manufacturing (TSMC), the previous digital transformation strategy has evolved, and now it is vigorously promoting smart manufacturing. Digital transformation is divided into three stages at TSMC: The first stage emphasizes three kinds of automation of machine, material transfer and wafer scheduling; the second stage integrates data analysis of wafer big data, machine learning techniques and domain-specific knowledge database; and the current third stage focuses on the realization of AI integration. A company's past digital transformation experience plays a key role in determining the efficiency and effectiveness of a company's adoption of AI, which also depends on how much benefit the company can achieve after the adoption of AI.

While companies are initially adopting AI as the first step to digital transformation, they still face broader organizational adaptability issues. Moreover, although both areas of digital transformation and AI have been extensively studied recently, there are also studies that have highlighted the importance of digital transformation and AI technologies for enhancing business processes, customer experience (Baiyere et al., 2020; Sahu et al., 2018) and decision analysis (Metcalf et al., 2019). However, gaps still exist and need to be further explored.

The rise of digital transformation and the development of AI have undoubtedly brought unprecedented opportunities and challenges. The organization's capacity to adapt to these novel work modalities is a primary consideration. While having big data and sophisticated computational systems might suffice for technical AI integration, an exclusive focus here might overlook the need for cultural and organizational adaptability, which might involve employee distrust due to the lack of transparency of emerging technologies (Holmström, 2022) or fears of job displacement (Agrawal et al., 2019). In order to avoid the adaptive problems derived from the above-mentioned organizational changes brought about by AI, this study further explores how to ensure organizations are fully prepared for the major changes to come when adopting these emerging technologies. In addition,

while existing research usually focuses on large enterprises, the prospects for digital transformation and AI applications in small and medium enterprises (SMEs) may be different. Due to limitations such as limited infrastructure and scarce resources, it is facing challenges to achieve phased and stable digital transformation. Large enterprises such as Netflix, Google, and Amazon provide practical and successful directions with their innovations in digital technologies and AI (Kepuska & Bohouta, 2018; Ram et al., 2018; Maedche et al., 2019). How SMEs can overcome the disadvantages brought about by the size of the enterprise through digital transformation is still a research gap that we aim to bridge. Therefore, the prompt adoption and seamless adaptation to these technological shifts emerge as critical business concerns.

Based on the above research background and gaps, this study aims to explore two research objectives: (1) To explore modern SMEs' digital transformation strategies by gain insights from senior executives on AI adoption to understand the prerequisites for digital transformation adoption and the value expected of it, to frame a strategic framework. (2) To validate the proposed digital transformation strategic framework through industry practices, emphasizing the correlation between the maturity of digital transformation and AI adaptation, providing comprehensive strategic recommendations.

## **LITERATURE REVIEW**

### **Digital Transformation**

The foundation of digital transformation lies in digitalization, which entails converting raw data, such as sound, images, and text, into digital formats. This facilitates cost-effective and convenient storage, replication, transmission, and processing (Chen, 2019). Digitalization is perceived as leveraging digital technologies to innovate business models and usher in new avenues for value creation and revenue generation (Verhoed et al., 2021). This phase is commonly seen as transforming into a digital business by utilizing digital technologies and information to alter business operations (Muro, Liu, Whiton, & Kulkarni, 2017). Typically, digitalization primarily targets operational aspects of the business realm rather than social interactions and business models, although these elements are intrinsically related.

The term "transformation" refers to the alteration of an enterprise's longstanding organizational structure, resource allocation, and strategic direction to reforge its competitive edge (Reeves et al., 2018). "Digital," on the other hand, alludes to digital tools employed for this transformation, including artificial intelligence, blockchain, and big data (Chan et al., 2020). Combining these concepts, digital transformation can be defined as a paradigm shift in an enterprise's value proposition driven by digital technologies. Through digital transformation, both the organizational planning and operational methods of an enterprise are radically restructured (Reis et al., 2018). This enables managers to integrate emergent technologies into their business models, thereby reshaping corporate strategy to enhance adaptability within both the business and broader environment. By leveraging organizational agility and rapid business capability development, enterprises can achieve strategic advantages in this data-driven era.

### **AI Adoption and Readiness**

The successful implementation of AI in enterprises necessitates a foundational technical infrastructure, which includes computational capabilities, storage capacity, and networking facilities to sustain AI applications. Additionally, the ability to adapt is crucial. Enterprises require technical professionals and AI experts who can adjust to ever-evolving technologies and their applications (Jöhnk et al., 2021). These skilled personnel are essential for effectively leveraging AI advancements. Moreover, data readiness is crucial. Enterprises must possess extensive, high-quality datasets and ensure robust data management and privacy safeguards (Issa et al., 2022). Talent acquisition is another vital component: enterprises require technical professionals and AI experts to adapt to ever-evolving technologies and their applications (Jöhnk et al., 2021). Additionally, managerial support is indispensable, necessitating clear AI strategies and management protocols to ensure the successful deployment of technology (Fontaine et al., 2019). Otherwise, once an organization introduces a new technology, there's a possibility that due to the reorganization of operational processes and workforce planning, it might find it difficult to adapt or even be unable to operate for a while, resulting in a decrease in efficiency.

The key motivators for AI adoption are enhanced efficiency, cost reduction, increased innovation, and a competitive edge (Hossain et al., 2022). However, as the adoption rate escalates, so too do the associated challenges, encompassing technical proficiency, technological familiarity, data quality issues, security threats, and legal and ethical concerns (Kushwaha & Kar, 2020). Furthermore, societal aspects must be taken into account when adopting AI. These include employee concerns about AI replacing jobs, the ramifications of AI on employment opportunities, and the public's acceptance of AI technologies (Cubric, 2020).

Therefore, when considering the adoption of AI, businesses must comprehensively assess the drivers, barriers, and societal impacts to optimize adoption outcomes. Overall, the adoption of AI reflects the trend of contemporary enterprises to improve efficiency and competitiveness. However, before adopting AI technology, enterprises must thoroughly evaluate and refine organizational culture, data quality, business model, and business strategy (Kushwaha & Kar, 2020).

## **METHODOLOGY**

### **Research Design**

This study explores the process enterprises undergo during the digital transformation phase and its implications for adopting AI technology. A two-stage qualitative research and case study approach employed to achieve this, providing further insights.

### Stage 1: Adoption of Digital Transformation in SMEs

In the first stage, this study investigates the impacts and transformations that the introduction/adoption of digital transformation brings to the organizational structures of SMEs. To address this issue, using the qualitative method, the existing literature on enterprise digital transformation is first analyzed. The study begins with the preliminary integration of digital transformation strategies and technological adoption. It understands organizational decision-making behaviors, internal operational dynamics, and strategies for successful transformation. Integrating the aforementioned aspects to enhance customer experience was also reviewed. Existing literature on organizational digital transformation indicates that senior executives emphasize enhancing customer experience, streamlining internal processes, and the advent of innovative service models as pivotal in the transformation process (Bahram, 2018). Hyvönen (2018) suggests that digital transformation planning and strategic deployment by senior managers within the organization are crucial determinants of successful transformation. Lichtenthaler (2020) argues that the successful digital transformation of an organization depends on leveraging emerging technologies such as big data and AI to reshape organizational behavior. Therefore, the qualitative research in the first stage formulates interview questions categorized into background, decision analysis, internal operations, transformation strategies, customer experience, and the benefits of transformation (as shown in Table 1).

Table 1: Interview topics for digital transformation of enterprises.

Topic.	Content	References
Background	<ol style="list-style-type: none"> <li>1. Demographics</li> <li>2. Industry environment</li> <li>3. Strategic plans of enterprise</li> <li>4. Internal changes in the enterprise</li> </ol>	Chien, 2019; Matt, Hess & Benlian, 2015; Westerman, Bonnet & McAfee, 2014
Decision analysis	<ol style="list-style-type: none"> <li>1. Identifying new profit opportunities</li> <li>2. Exploring innovative cost-reduction strategies</li> <li>3. Adapting for environmental changes</li> </ol>	Hyvönen, 2018; Lichtenthaler, 2020; Provost & Fawcett, 2013
Internal operations	<ol style="list-style-type: none"> <li>1. Talents specialized in digital transformation</li> <li>2. Transforming, integrating, or establishing new departments through digital transformation</li> <li>3. Establishing performance metrics to evaluate the outcomes of digital transformation strategies</li> </ol>	Provost & Fawcett, 2013; Westerman, Bonnet & McAfee, 2014; Gurbaxani & Dunkle, 2019
Transformation strategies	<ol style="list-style-type: none"> <li>1. Innovation management and operations across organizational departments</li> <li>2. Allocating a proportionate investment in the realm of digital transformation</li> <li>3. Building more collaborative partnerships to generate additional benefits</li> <li>4. Experimenting with novel working methodologies</li> </ol>	Lichtenthaler, 2020; Hyvönen, 2018; Hellbe & Leung, 2015; Kane et al., 2015
Customer experience	<ol style="list-style-type: none"> <li>1. Recognizing shifts in customer demands</li> <li>2. Evolution in promotional and marketing strategies</li> <li>3. Designing the customer experience journey</li> </ol>	Chalabi, 2018; Tabrizi et al., 2019
Benefits of transformation	<ol style="list-style-type: none"> <li>1. Achievements in brand marketing</li> <li>2. Enhancing workflow efficiency</li> <li>3. Boosting customer satisfaction</li> </ol>	Chanas, 2017; Hyvönen, 2018; Hellbe & Leung, 2015; Pousttchi et al., 2019; Chalabi, 2018.

Source: This study.

### Stage 2: Adaptation of AI in Enterprise

AI, an emerging and maturing research domain, has seen rapid advancements predominantly pushed by the private sector (Wirtz & Müller, 2019). However, examples of the comprehensive and successful integration and transformation of AI into organizations are lack of deeper discussion. Therefore, the second stage employ a mix-method, focusing on enterprises that have shown promising digital transformation outcome in the first stage. This stage aim to determine organizational readiness in adopting AI technologies, thus we integrates case studies with qualitative interviews of senior executives. This assessment is based on hierarchical dimensions that measure readiness for AI technology adoption (Alsheibani et al., 2018). These dimensions are categorized as Technical Readiness (TR), Organizational Readiness (OR), and Environmental Readiness (ER). TR assesses the propensity of organizations to accept and use new technologies, which is crucial for the application and development of AI (Flavián et al., 2022). This includes internal technological infrastructure and the state of prevailing technologies in external markets (Martínez -Plumed et al., 2021), helping enterprises predict the benefits of technology adoption. OR indicates an organization's ability to embrace technological change and should be viewed from the perspectives of leadership, culture, organizational structure, talent, and technological infrastructure. This ensures that new technologies fully realize their value and advantages (Pumplun et al., 2019). ER represents an organization's preparedness to consider environmental impacts before adopting new technologies, taking into account cultural, political, and legal aspects. This emphasizes the adaptation of the organization in response to the external turbulent environment. Based on the existing literature, this study further identifies each topics based on these three dimensions to explore the corresponding adaptation strategies (as shown in Table 2).



Table 2: Interview topics for adaptability of enterprises to AI adoption.

Topic.	Content	References
Technical Readiness (TR)	1. Relative Advantage 2. Compatibility	Chang <i>et al.</i> , 2020; Flavián <i>et al.</i> , 2022
Organizational Readiness (OR)	1. Supervisor support 2. Organizational size 3. Internal resources	Collins 2021; Jöhnk <i>et al.</i> , 2021; Pumplun <i>et al.</i> , 2019
Environmental Readiness (ER)	1. Competitive pressure 2. Government regulations	Gutierrez <i>et al.</i> , 2015

Source: This study.

### Data Collection

In the first stage, one-on-one semi-structured interviews were conducted with senior executives from 30 SMEs in Taiwan. Each interview was about within a duration of 30 to 40 minutes. The discussion focuses on the current industrial status of the digital transformation of modern enterprises, establishes a research framework for the strategic deployment of digital transformation, and provides reference for practical applications. At the same time, the enterprise with the highest readiness for AI adoption was chosen for further investigation in stage 2. Finally, the case enterprise (Company A) belonging to the technology industry was selected for the second stage.

Company A offers testing and validation services across various sectors, including component industries, consumer electronics, and the automotive sector. It acts as a significant collaborator and quality gatekeeper in multiple domains. Company A adopts a variety of digital technologies and equipment, and ensures impartial verification to guarantee products have undergone reliability testing and failure analysis before they go on the market. Company A exhibits comprehensive digital transformation outcomes given its services and operational model. Semi-structured interviews focusing on the three dimensions of AI readiness will be conducted with senior managers from departments highly associated with AI adoption of Company A. The duration of interviews is controlled at around 30 to 40 minutes. Based on these research findings, a strategic model for 'AI adaptation in digital transformation' will be developed. Then, it is validated by empirical data.

## FINDINGS AND DISCUSSION

### Adoption Strategies of Digital Transformation in SMEs

Before undertaking digital transformation, executives should carefully evaluate three dimensions of the enterprise: An external **environmental evaluation**, including market trends and competitors' behaviors; **internal evaluation** of employees' understanding of digital technologies and the level of digitization of data and tools; and **customer-relationships** evaluation involves observing changes in customer needs and planning the customer journey.

The product market in Taiwan is generally characterized by a small size, leading to intense competition. Enterprises are keen to pioneer new product development or innovative service models to stand out from competitors. A key element of this competitive landscape is the ability to leverage information. As mentioned by an advertising agency manager *"From my experience in the industry, I've seen how the global landscape has shifted. With the rise of the digital age and the use of big data, we, as managers, need to keep up with changing trends, market shifts, and evolving consumer behaviors. It's especially important to understand how consumers interact with things like smart devices, digital media, and social platforms. Getting a grasp on their habits and behaviors helps us get a clearer picture of their decision-making process. Through big data analytics techniques, we can gain a better understanding of their habits and behaviors, which aids us in gaining a clearer insight into their decision-making. That way, we can tailor our marketing strategies to align better with their needs and actions"*. It showed only when enterprises obtain massive and diverse information they can formulate transformation strategies that are both innovative and risk-averse. Many executives believe that in addition to mastering the technology of information utilization, they must acquire knowledge from a wider range of fields. Another HR representative from a different advertising company said, *"We have been hiring more technical talents who possess not only digital-related skills but also soft skills such as critical thinking and business acumen. These individuals can serve as internal seeds, generating guidance on educational and operational aspects."* We can also observe that by hiring employees who are proficient in these **new technologies and knowledge**, or by collaborating with industry across sectors, thereby expanding the range of decision-making options to achieve **innovative products and services**, gaining a strong competitive edge.

For enterprises, the tangible impact of digital transformation can be distinguished by examining the **changes in organizational behavior** brought about by digital technologies. Most enterprises that have either completed or are undergoing digital transformation demonstrate a shift in organizational behavior. The integration of digital technology, both in terms of software and hardware, anchors the foundation for **digitalization and digitization** within the organization. This facilitates the simplification and standardization of **internal operational processes**. As said by an interviewed company CEO, *"The majority of our management systems are already in a digitized state. Internally, data management and platform development, as well as customer interaction and service at the front end, have all benefited from this digitalization. It has also facilitated the rapid implementation of our ERP system, significantly shortening many of our daily processes."* Furthermore, to ensure that

employees' competencies align with the adopted tools and workflows, organizations frequently offer technical training tailored to these newly implemented software and hardware solutions, thus ensuring that the organization possesses a substantial level of **digital foundation** in both its technological infrastructure and workforce. As said by one of the interviewed managers in insurance industry *"We're in the sales department and have this system called the "57 Reports." It covers everything from our daily tasks and training to performance results. All our salespeople have to input their data daily, and the system sorts and calculates everything for them. It's been a game-changer for us. Our company invested a lot in developing it. Not only do we use it here in Taiwan, but our branches in mainland China use it too. Considering China's vast geographical scope, this system is especially important when our branches in mainland China need to share and integrate data."* Especially for enterprises with a lot of business activities, on-job training for applications such as CRM, ERP, financial management, and cloud systems is crucial. These **enterprise management systems** ensure that new technical capabilities can be swiftly integrated, replacing previous operational methods. As stated by two interviewed CEOs from technology companies, *"It's crucial that all members of the organization maintain a habit of continuous learning in order to swiftly adapt to these new work methodologies following the implementation of new technologies."* Additionally, one CEO noted, *"Our team members are already well-versed in digital work patterns, so when new technologies are introduced, their receptiveness is high, and their adaptation is remarkably swift."*

The main goal of companies undergoing digital transformation is to **find new avenues of profit**, whether it is to reduce costs or develop new revenue streams. Most enterprises leverage digital technologies to **consolidate resources or platforms**, eliminate redundant processes, reduce personnel costs, and enhance operational efficiency. The founder of a certain chain of coffee shops also mentioned, *"I introduced a POS system at the beginning of 2020. It's cloud-based and enables real-time analysis, allowing me to remotely organize marketing activities for employees. It also integrates systems from other platforms. After merging our delivery and mobile payment systems, we significantly streamlined many of our previous processes."* This need was especially evident during the impact of COVID-19. *"The old way of doing things was pretty inefficient and often inaccurate. When everything was on paper, we constantly faced these issues such as passing information was slow, and during that process, there'd be delays and mistakes. But after going digital, many of these problems were solved. With a solid digital setup, information can be shared way faster and more accurately. The benefits of digital transformation are really clear in this."* said by a technology company manager. Traditional processes such as physical document signing, submission and review can become more time-consuming if they still rely on paper and manual delivery. Such inefficiencies could significantly impact customer retention and renewal rates. Therefore, the widespread adoption of digitally encrypted electronic contracts and online purchase or renewal mechanisms on digital platforms can create more business opportunities and reduce unnecessary commuting by employees. At the same time, this also enhances operational efficiency and **improves the modes of service or product delivery**, resulting in a better experience for customers.

As various digital systems and technologies are integrated into enterprises, the tangible results of digital transformation will be reflected in **customer experience**. The Chief Operating Officer of a certain company expressed, *"When it comes to customer experience, from a digital perspective, it's about user experience. At times, customers using our platform may not attain the desired experience. As a result, we continually engage with customers to gather data on this user experience. After analysis and confirmation, we can present what's known as the User Interface (UI), enabling customers to become familiar and swiftly adapt to the platform. This not only helps us maintain a close relationship with customers but also fosters their loyalty towards us."* By leveraging digital tools to collect data from customers and subsequently analyzing that data, enterprises can realize consumer behavior and habits. This enables them to **anticipate and offer corresponding products or services** even before the customers recognize their needs. Or design special marketing campaigns based on data, such as new product launches or promotions, in order to **maintain customer loyalty and engagement**. Furthermore, these insights can facilitate the **expansion of new customer segments**, enabling businesses to be well-prepared to enter previously untapped markets with lower risks. Similarly, as expressed by another interviewed manager from a health technology company, *"Online platform-centric e-commerce models are also evolving into the mainstream. We can transform products into 3D representations, refreshing how they are presented to appeal to a broader customer base. Moreover, in the B2C sales domain, data-driven Martech allows for more refined customer segmentation. This optimization not only enhances customer retention rates but also facilitates lower-risk and swifter expansion into new markets."* Compared with data-driven decision-making, making decisions based solely on traditional empirical indicators is like looking only in the rearview mirror while driving, blurring the path and direction ahead. Such a narrow focus also hinders organizations' ability to prepare for and adapt to emerging innovations, such as adaptation issues in second-stage AI technologies, e.g., environmental readiness, organizational readiness and technical readiness.

It can be seen that the current digital transformation has laid a basic framework for the integration of AI technology within the enterprise. If an enterprise wants to achieve sustainable and long-term growth (as shown in Figure 1), at the initial stage of digital transformation, it is necessary to carefully evaluate the internal and external environment of the enterprise and the current status of customer relationships. They can enhance their competitive edge by swiftly incorporating emerging technologies and knowledge. This enhancement not only improves organizational operations and uncovers new avenues of profit, but also improves customer relationship management on the business side. The accumulated benefits are used as feedback to further enhance the competitiveness of enterprises and make them more adaptable and resilient to cope with changing environments, technological advancements and competitive challenges. Once AI technology is introduced, it will bring about significant changes both internally and externally within the organization. Many aspects of manpower, processes, and resources will require a thorough reassessment. We can interpret this scenario as a major environmental upheaval, where

organizations with a strong foundation in digital transformation possess the ability to quickly absorb and adapt to entirely new technologies and changes. This allows them to rapidly enhance their competitiveness while mitigating risks, ultimately achieving the goal of sustainable operations.

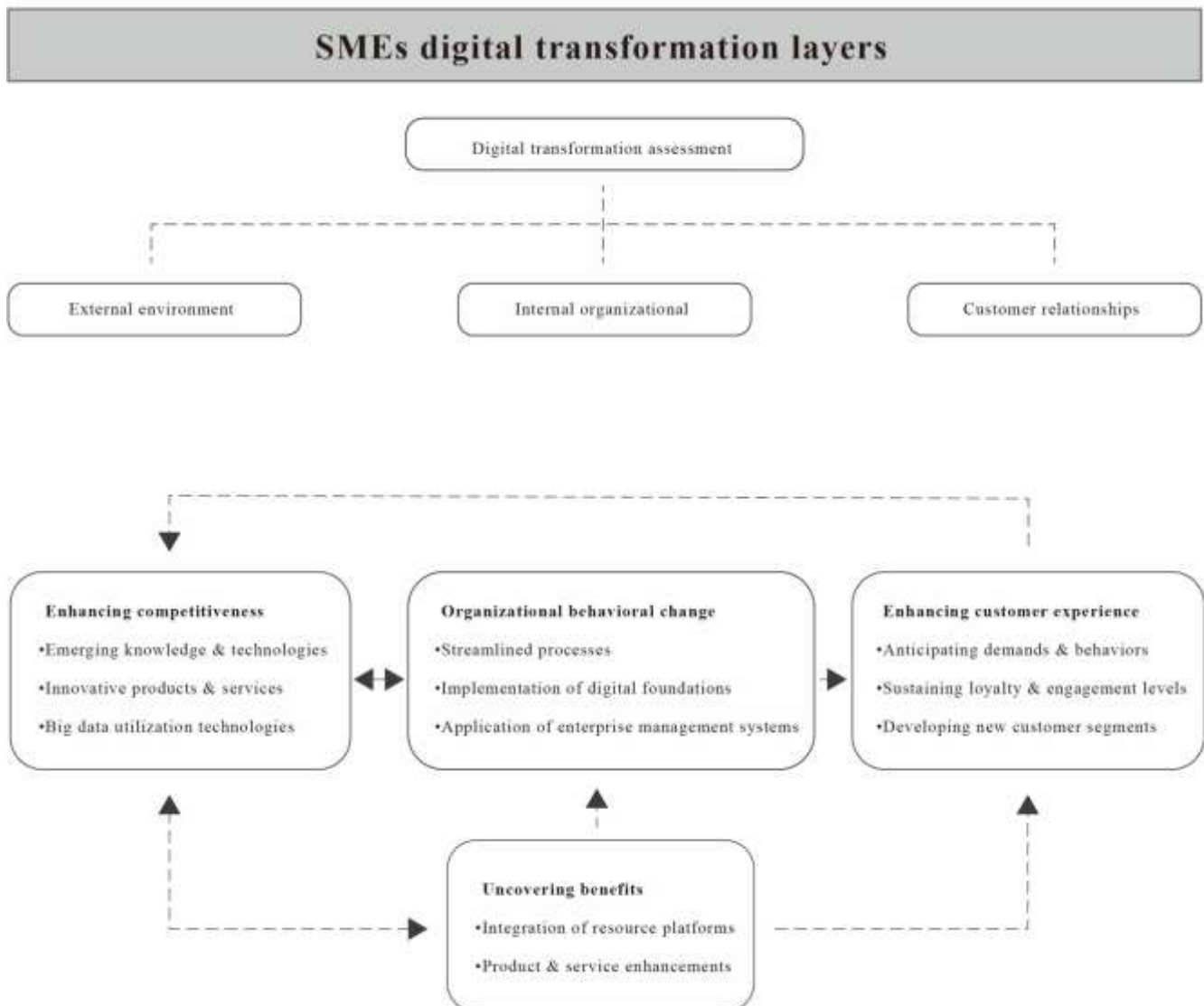

Figure 1: Adoption of Digital Transformation Strategy Framework

### Adaptation of AI in Enterprise

When enterprises consider adopting AI technology, the **surrounding environment** often plays a key role. Especially in times of increased competition in an industry, there tends to be a strong drive to embrace new technologies. As stated by the R&D manager of Company A, "GPT has sparked a trend across the entire internet, making it feel outdated if one hasn't utilized it. I believe such a trend will also drive us to incorporate artificial intelligence." However, most businesses, especially SMEs, do not yet have the technical capabilities to effectively utilize AI. Hence, senior decision-makers are in a high-pressure observational mode. Any **keen market demand** may represent an opportunity to pioneer new technological advancements within the industry, thereby increasing the competitive advantage of the enterprises. Meanwhile, as Company A's engineering manager points out, "If our competitors are already adopting this trend, it could greatly affect us. Hence, we need to monitor how extensively our rivals are employing AI." The level of AI implementation among competitors will also be a key area of focus. As mentioned earlier in the context of digital transformation, many countries have developed comprehensive policies to promote digital transformation technologies. Its goal is to synchronize digital transformation efforts between enterprises and government entities to modernize urban society, promote industrial progress, and enhance national economic competitiveness. R&D Manager in Company A considered "If the government gives incentives and support, I believe companies will definitely go down that path. I totally agree from my perspective. It's like riding along with the government's policy, and it might even give us a boost in marketing." If a **policy to encourage the development of AI** is introduced, it is likely to cause enterprises to respond positively and formulate an AI technology integration strategy.

After ensuring adequate external and environmental readiness, the internal readiness of the organization becomes a key aspect of the second stage assessment. This includes factors such as **senior management support** and planning as well as human

resources and digital assets within the organization. This stage critically influences whether integrating AI yield significant benefits for the enterprise. Senior management endorsement plays a salient role in determining **AI implementation strategies, resource allocation, and risk management**. Engineering Manager in Company A said *“Our boss has told us that if we have any needs or ideas, we should bring them to the team. Of course, they'll be scheduled based on priority and urgency. So, in general, the boss support us diving into AI stuff.”* Data manager in Company A also mentioned, *“If I propose AI-driven decisions, such as hiring relevant talent, it can save the company a lot of costs and bring new opportunities. Typically, the bosses are fully supportive as they are also highly interested in this aspect.”* In other words, lack of AI technical knowledge among senior executives can lead to decision-making indecision, potentially leading to impractical or unattainable visions that could diminish organizational morale.

Operation Manager in Company A said *“We don't need to bring AI into every department in our company. Each one has its own way of doing things. Just because you adopt and use AI doesn't mean it'll be more efficient. The time and challenges faced when introducing AI can vary, leading to different outcomes in different situations.”* The decision to integrate AI isn't just based on the size of a department or its volume of business. The data manager at Company A shares a similar viewpoint: *“I believe the implementation of artificial intelligence is closely tied to the operational models of various departments. It doesn't necessarily mean that smaller units don't need it or that larger ones always do. The key factor is alignment with the operational model. If their department's workflow is conducive to it, such as in cases of high repetition, we can find elements of automation or artificial intelligence to assist them. However, if their tasks involve highly variable attributes requiring human testing, then using AI technology wouldn't be suitable as a replacement.”* The resources available within the different organizational units must first be determined. The **evaluation and reconfiguration of hardware and software should be included** in strategic planning for AI adoption. Senior executives should work with technical teams to determine whether upgrading or replacing existing equipment is necessary to ensure they are adequately prepared to maintain the operations and growth of AI applications. This may involve purchasing high-performance servers, massive computing power and expanded data storage capacity. At the same time, the selection of software tools and platforms should consider meeting the specific requirements of AI applications.

Technical readiness can be considered the last step in integrating AI technologies, and arguably the most critical assessment. This level of readiness determines whether a company can quickly adapt and replace existing operating methods when AI is integrated. The stability, efficiency and scalability of the technology, especially in the initial stages of integration, will affect the **efficiency and cost reduction** results of AI, bringing risks of project failure and waste of resources. *“We must first understand what AI can do for us and how far its tech goes. ... can we integrate reports into AI? Who can help us with this? That's what we should be focusing on first. We should see if we can use the company's resources and feed our current information into AI for analysis.”* as the operation manager mentioned. For example, while AI-driven robots and virtual assistants can enhance customer service and operational efficiency to some extent, the absence of a precise understanding of employee and customer needs, coupled with appropriate functionalities, could yield counterproductive results. Especially when errors in understanding occur in human-computer interactions, they could potentially lead to a slowdown in employee workflows or trigger customer distrust in artificial intelligence. Ultimately, this could have a significant impact on **production capacity and customer experience**.

*“When I ask ChatGPT a question, it might give me a wrong answer. How can I prevent that? For most people, a mistake by ChatGPT just seems like a simple error, but for our lab, it could hurt our reputation.”* The foundational element of artificial intelligence is its reliance on substantial data for learning and prediction. This challenges an organization's foundational digital transformation efforts. Data-driven AI applications are only possible with massive and consistent digital data, supplemented by processing and storage capabilities. *“If the data you want to analyze isn't digitized, if there isn't enough data volume, or even if there isn't sufficient technical capability to apply, then basically, the discussion about artificial intelligence isn't necessary.”* Without such data, the expected **data value of AI** may not be achieved, potentially compromising the **credibility and accuracy** of AI tools and algorithms. It's crucial to avoid misplaced trust in erroneous or misguided AI recommendations that could adversely affect an organization's operations and reputation.

Finally, based on the information gathered from the semi-structured interviews, we conducted a qualitative analysis of the three dimensions of corporate readiness and developed a strategic framework for AI adoption (shown in Table 3). This framework clarifies the approach to take once the clear outcomes of AI are evident. It emphasizes the importance of observing external environmental shifts related to the business, verifying the organization's readiness for AI integration, and identifying the essential technical skills to optimize AI's advantages. Furthermore, it highlights the importance of swift adjustment to subsequent sweeping organizational changes.

Table 3: AI Adaptation Strategy Framework.

AI Integration Layers		
Environmental readiness	Organizational Readiness (OR)	Technical Readiness (TR)
1. Focus on market demands and competitive pressures. 2. Competitors' actions serve as the optimal driving force. 3. Incentive policies from government agencies can generate positive feedback.	1. Positive attitude of senior executives. 2. Organization's business and operational models. 3. Resource replanning and utilization.	1. Efficiency and cost-effectiveness. 2. Enhanced customer experience and productivity. 3. Data value breakthrough. 4. Tool reliability and accuracy.

### Empirical Validation by Case Enterprise

In the verification case of Company A, the "Red Ink Test" was conducted specifically for business operations that rely most on manual labor, as a pilot for the introduction of AI technology. The Red Ink Test serves as a method for assessing the soldering conditions of electronic components. This is achieved by observing the staining of solder joints to detect their quality, thereby preventing voids or breaks in the soldering process. This current method is time-consuming and heavily dependent on manual observation and intervention. To increase efficiency and determine the benefits of AI integration, Company A utilizes optical microscopy to capture the condition of components. Based on these observations, abnormalities were marked on coordinates (as shown in Figure 2). Furthermore, microscopy images were captured at a 25x magnification to produce a panoramic view, which was subsequently transformed into an Excel presentation. These images are then cropped to augment the dataset, providing sufficient training data for the machine learning model to perform initial binary classification training.

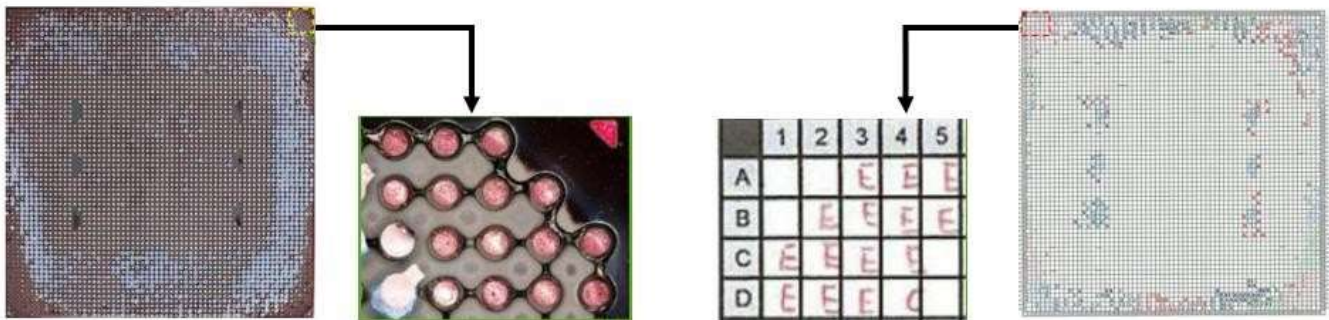

Figure 2 Abnormal mark

Upon completing the data organization of the experimental results stored in the database, Company A created labels for input into the machine learning model for subsequent training. Company A consistently augments its data, which has resulted in successful training outcomes. Company A plans to implement an automated defect identification and entry process in the next phase using the machine learning model. This aims to streamline the Red Ink test workflow to a fully automated process, just one more manual check is required. Our findings indicate that Company A has achieved promising results in introducing AI technology into its business operations and has demonstrated rapid adaptability. They have changed their culture, processes, and adapted to economic, regulatory, and policy changes in the external environment. This success relies on the company's solid foundation in digital transformation. During the digital transformation phase, they actively seek to acquire new technological capabilities. Through the digitization of various business data, operational processes are simplified, and organizational flexibility is enhanced through resource integration, enabling them to dynamically adjust resource scheduling and allocation to predict and improve customer needs. Ultimately, one of the key achievements of digital transformation includes the establishment of a comprehensive digital database containing historical experimental data. In addition, the enterprise's familiarity with AI technology, its understanding of its potential advantages when integrated into business processes, and its diverse skills in processing, scaling, and applying this data, are aligned with our two-stage strategic model built on qualitative analysis resonance. The case also emphasizes that a solid foundation for digital transformation can significantly improve the efficiency and effectiveness of the evaluation, reorganization, and adaptation of AI technology into the enterprise. Consequently, our research ultimately incorporates the two-stage model to propose an overall strategic framework for enterprise-wide transformation (as shown in Figure 3). This strategic framework suggests that companies can initially establish a stable foundation for digital transformation as a preliminary strategy. By gradually digitizing organizational processes, equipment, and technology, they can acquire the ability to adapt to significant changes. Before adopting artificial intelligence technologies, three readiness assessments should be conducted to understand the benefits, requirements, and potential changes that AI technology may bring to the organization. With a solid foundation in digital transformation strategy, the organization's adoption of artificial intelligence technologies in the second phase will be more rigorous, enabling a better insight into potential benefits and risks.

## CONCLUSION

### Conclusion

This study examines the preparatory measures required for adopting AI technology during the different stages of a firm's digital transformation. It underscores the iterative development enterprises undergo during the transformation process,

emphasizing that a robust digital transformation is the bedrock for the successful deployment of AI technology. By harnessing digital technologies, firms can re-engineer organizational planning and business models, equipping themselves with the prerequisites for AI adoption and fostering a conducive environment for successful AI integration. Senior executives must possess a discerning vision to assess their firm's strengths and weaknesses. Through careful evaluation and analysis, they can identify critical areas for investment and conceptualize how these technologies dovetail with their business models, cultivating new value and competitive advantages. Additionally, these senior executives must exhibit unwavering commitment and a propensity for risk-taking and innovation. While digital transformation and AI adoption might harbor risks and uncertainties, they concurrently usher in unparalleled opportunities. Senior executives should champion innovative thinking, permit experimentation and occasional setbacks, and adjust strategies promptly in response to evolving landscapes.

### **Limitation**

Due to time constraints, this study has limited capacity to examine the integration of AI in a two-stage approach across multiple enterprises progressing in the digital transformation process. It is also noteworthy that while AI rapidly evolves, it has yet to fully mature. As a result, there are only a handful of tools available that can bring about immediate transformational change in enterprises. Most of these tools require a careful, multifaceted assessment of the company. Conducting such an experiment in a more expansive enterprise might necessitate an in-depth review, which could entail several top-tier discussions within the subject company, potentially lengthening the research timeline and affecting the data's reliability. When this topic is discussed further, follow-up data collection on the case study companies is expected to facilitate comparative analysis.

Furthermore, for future research, it's possible to extend the research methodology, such as employing the Fuzzy Set Qualitative Comparative Analysis (FSQCA). In this two-stage and contextually complex study, using FSQCA ensures the inclusion of all relevant factors while also enhancing the robustness of the research framework through the incorporation of quantitative data.



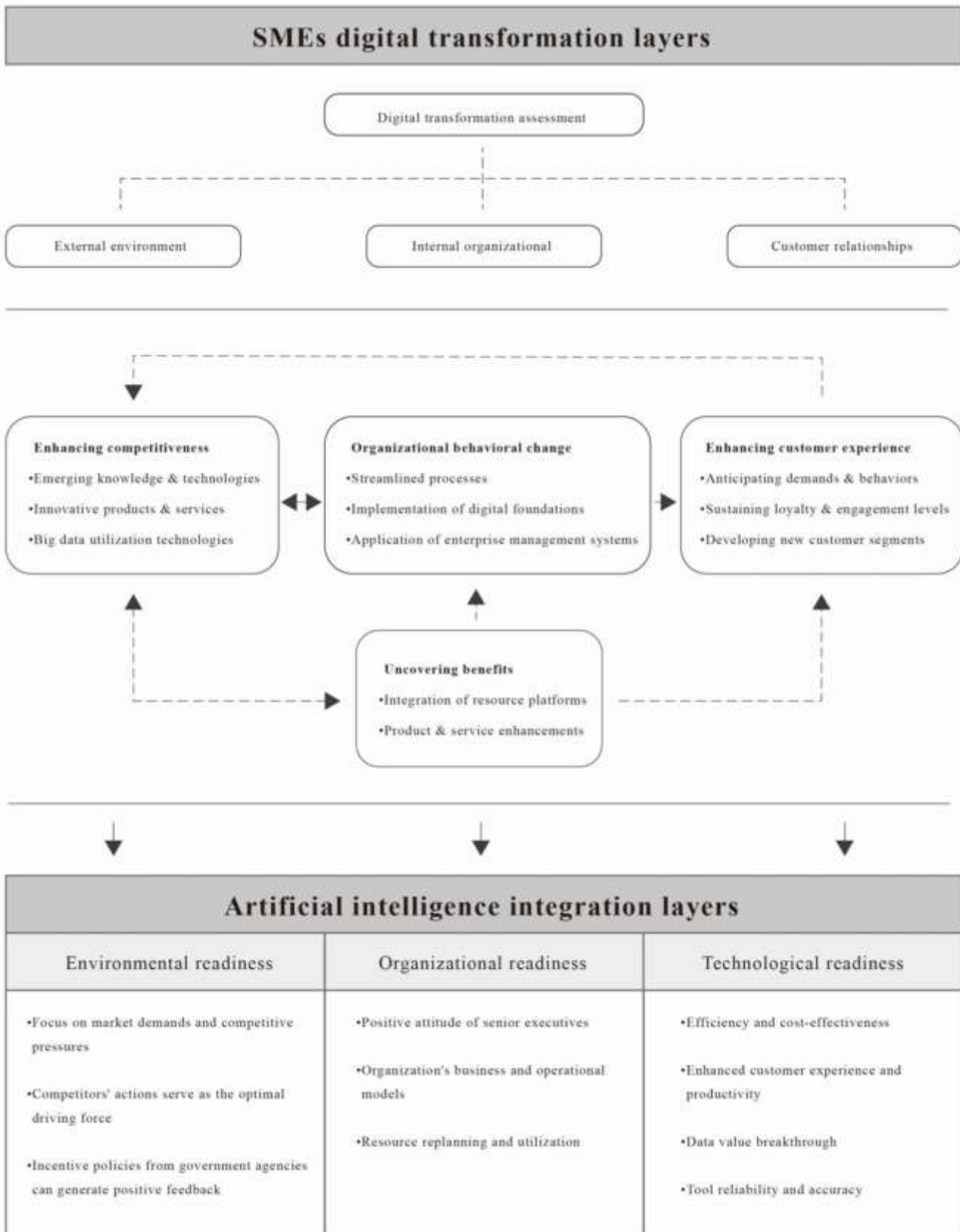

Figure3: Digital Transformation Adoption to Adaptation Framework

**REFERENCES**

Alsheibani, S., Cheung, Y., & Messom, C. (2018). Artificial intelligence adoption: AI-readiness at firm-level. In M. Tanabu & D. Senoo (Eds.), *Proceedings of PACIS2018: Pacific Asia Conference in Information Systems (PACIS)* (pp. 231-245). Association for Information Systems.



- Al-Chalabi, M., & Bahram, L. (2018). The Digital Transformation of the Swedish Banking Industry : A study on the digitalisation of Swedish banks and how it affects their perspective on customer experience (Dissertation). Retrieved from <https://urn.kb.se/resolve?urn=urn:nbn:se:uu:diva-360164>
- Agrawal, A., Gans, J. S., & Goldfarb, A. (2019). Artificial intelligence: the ambiguous labor market impact of automating prediction. *Journal of Economic Perspectives*, 33(2), 31-50.
- Baiyere, A., Salmela, H., & Tapanainen, T. (2020). Digital transformation and the new logics of business process management. *European Journal of Information Systems*, 29(3), 238-259.
- Berghaus, S., & Back, A. (2016). Stages in digital business transformation: Results of an empirical maturity study. In *Tenth Mediterranean Conference on Information Systems (MCIS)*, Paphos, Cyprus.
- Bloomberg, J. (2018). Digitization, digitalization, and digital transformation: confuse them at your peril. *Forbes*. Retrieved on August, 28, 2019.
- Brock, J. K. U., & Von Wangenheim, F. (2019). Demystifying AI: What digital transformation leaders can teach you about realistic artificial intelligence. *California Management Review*, 61(4), 110-134.
- Chan, W. N., Lee, C. H., Chou, W. C., & Wang, Y. C. (2020). Digital Transformation Capability. Taipei City: *Business Weekly Publications*.(Chinese)
- Chang, N., Zhang, Y., Lu, D., Zheng, X., & Xue, J. (2020, December). Is a disruptive technology disruptive? The readiness perspective based on TOE. In 2020 IEEE International Conference on *Industrial Engineering and Engineering Management (IEEM)* (pp. 893-897). IEEE.
- Chen, C. H. (2019). Unraveling the Digital Transformation Secrets of LEGO's World Brand Award Achievement. *Taiwan Economic Research Monthly*, 42(10), 66-72. [https://doi.org/10.29656/TERM.201910\\_42\(10\).0009](https://doi.org/10.29656/TERM.201910_42(10).0009)
- Chien, S. M. (2019). Organizational and Talent Challenges and Strategies under Digital Transformation. *Taiwan Economic Research Monthly*, 42(10), 48-55. [https://doi.org/10.29656/TERM.201910\\_42\(10\).0007](https://doi.org/10.29656/TERM.201910_42(10).0007)(Chinese)
- Cubric, M. (2020). Drivers, barriers and social considerations for AI adoption in business and management: A tertiary study. *Technology in Society*, 62, 101257.
- Davenport, T. H., & Ronanki, R. (2018). Artificial intelligence for the real world. *Harvard business review*, 96(1), 108-116.
- Davidovski, V. (2018, November). Exponential innovation through digital transformation. In *Proceedings of the 3rd International Conference on Applications in Information Technology* (pp. 3-5).
- Flavián, C., Pérez-Rueda, A., Belanche, D., & Casaló, L. V. (2022). Intention to use analytical artificial intelligence (AI) in services—the effect of technology readiness and awareness. *Journal of Service Management*, 33(2), 293-320.
- Fountaine, T., McCarthy, B., & Saleh, T. (2019). Building the AI-powered organization. *Harvard Business Review*, 97(4), 62-73.
- Ghosh, B., Daugherty, P. R., Wilson, H. J., & Burden, A. (2019). Taking a systems approach to adopting AI. *Harvard Business Review*, May 09, 2019, 1-6.
- Gurbaxani, V., & Dunkle, D. (2019). Gearing Up For Successful Digital Transformation. *MIS Quarterly Executive*, 18(3), 209-220. <https://doi.org/10.17705/2msqe.00017>
- Gutierrez, A., Boukrami, E., & Lumsden, R. (2015). Technological, organisational and environmental factors influencing managers' decision to adopt cloud computing in the UK. *Journal of Enterprise Information Management*, 28(6), 788-807.
- Hellbe, S., & Leung, P. (2015). Digital transformation : how apis drive business model change and innovation (Dissertation). Retrieved from <https://urn.kb.se/resolve?urn=urn:nbn:se:liu:diva-119506>
- Holmström, J. (2022). From AI to digital transformation: The AI readiness framework. *Business Horizons*, 65(3), 329-339.
- Hossain, M. A., Agnihotri, R., Rushan, M. R. I., Rahman, M. S., & Sumi, S. F. (2022). Marketing analytics capability, artificial intelligence adoption, and firms' competitive advantage: Evidence from the manufacturing industry. *Industrial Marketing Management*, 106, 240-255.
- Hyvönen, J. (2018). Strategic leading of digital transformation in large established companies—a multiple case-study (Dissertation). Aalto University, School of Science, Degree Programme in Industrial Engineering and Management.Helsinki.
- Issa, H., Jabbouri, R., & Palmer, M. (2022). An artificial intelligence (AI)-readiness and adoption framework for AgriTechfirms. *Technological Forecasting and Social Change*, 182, 121874.
- Jöhnk, J., Weißert, M., & Wyrski, K. (2021). Ready or not, AI comes—an interview study of organizational AI readinessfactors. *Business & Information Systems Engineering*, 63, 5-20.
- Kane, G. C., Palmer, D., Phillips, A. N., Kiron, D., & Buckley, N. (2015). Strategy, not technology, drives digitaltransformation. *IT Sloan Management Review* (2015): July 14, 2015.
- Kepuska, V., & Bohouta, G. (2018). Next-generation of virtual personal assistants (microsoft cortana, apple siri, amazon alexa and google home). In *2018 IEEE 8th annual computing and communication workshop and conference (CCWC)* (pp. 99-103). IEEE.
- Kosior, K. (2018). Digital transformation in the agri-food sector—opportunities and challenges. *Roczniki (Annals)*, 2018(1230-2019-3703).

- Lichtenthaler, U. (2020). Building Blocks of Successful Digital Transformation: Complementing Technology and Market Issues. *International Journal of Innovation and Technology Management*, 17(01). <https://doi.org/10.1142/s0219877020500042>
- Kushwaha, A. K., & Kar, A. K. (2020). Micro-foundations of artificial intelligence adoption in business: Making the shift. Re-imagining Diffusion and Adoption of Information Technology and Systems: A Continuing Conversation: IFIP WG 8.6 International Conference on Transfer and Diffusion of IT, TDIT 2020, Tiruchirappalli, India, December 18–19, 2020, Proceedings, Part I,
- Maedche, A., Legner, C., Benlian, A., Berger, B., Gimpel, H., Hess, T., ... & Söllner, M. (2019). AI-based digital assistants: Opportunities, threats, and research perspectives. *Business & Information Systems Engineering*, 61, 535-544.
- Martínez -Plumed, F., Gómez, E., & Hernández-Orallo, J. (2021). Futures of artificial intelligence through technology readiness levels. *Telematics and Informatics*, 58, 101525.
- Matt, C., Hess, T., & Benlian, A. (2015). Digital transformation strategies. *Business & Information Systems Engineering*, 57, 339-343.
- Metcalf, L., Askay, D. A., & Rosenberg, L. B. (2019). Keeping humans in the loop: pooling knowledge through artificialswarm intelligence to improve business decision making. *California Management Review*, 61(4), 84-109.
- Muro, M., Liu, S., Whiton, J., & Kulkarni, S. (2017). Digitalization and the American workforce. Metropolitan Policy Program Brookings. November 2017.
- Organisation for Economic Co-operation and Development. (2019). *Measuring the digital transformation: A roadmap for the future*. Organisation For Economic Co-operation and Development.
- Pousttchi, K., Gleiss, A., Buzzzi, B., & Kohlhagen, M. (2019). Technology Impact Types for Digital Transformation. Paper presented at the 2019 *IEEE 21st Conference on Business Informatics (CBI)*
- Provost, F., & Fawcett, T. (2013). Data Science and its Relationship to Big Data and Data-Driven Decision Making. *Big Data*, 1(1), 51-59. <https://doi.org/10.1089/big.2013.1508>
- Pumplun, L., Tauchert, C., & Heidt, M. (2019). A new organizational chassis for artificial intelligence-exploring organizational readiness factors. In *Proceedings of the 27th European Conference on Information Systems (ECIS)*, Stockholm & Uppsala, Sweden, June 8-14, 2019. ISBN 978-1-7336325-0-8 Research Papers.
- Ram, A., Prasad, R., Khatri, C., Venkatesh, A., Gabriel, R., Liu, Q., & Pettigrew, A. (2018). Conversational ai: The science behind the alexa prize. *arXiv preprint arXiv:1801.03604*.
- Reeves, M., Faeste, L., Whitaker, K., & Hassan, F. (2018). The truth about corporate transformation. *MIT Sloan Management Review*, 59(3), 1-7.
- Reis, J., Amorim, M., Melão, N., & Matos, P. (2018). Digital transformation: a literature review and guidelines for future research. *Trends and Advances in Information Systems and Technologies: Volume 1* 6, 411-421.
- Sahu, N., Deng, H., & Mollah, A. (2018). Investigating The Critical Success Factors Of Digital Transformation For Improving Customer Experience. In *CONF-IRM 2018 Proceedings* (p. 18). Retrieved from <https://aisel.aisnet.org/confirm2018/18>
- Schumpeter, J. A. (1939). *Business Cycles: A Theoretical, Historical, and Statistical Analysis of the Capitalist Process*. McGraw-Hill, New York.
- Tabrizi, B., Lam, E., Girard, K., & Irvin, V. (2019). Digital transformation is not about technology. *Harvard business review*, 13(March), 1-6.
- Taiwan Semiconductor Manufacturing Company (2022). *TSMC 2021 Annual Sustainability Report - ESG*. Retrieved from [https://esg.tsmc.com/download/file/2021\\_sustainabilityReport/english/e-all.pdf](https://esg.tsmc.com/download/file/2021_sustainabilityReport/english/e-all.pdf)
- Verhoef, P. C., Broekhuizen, T., Bart, Y., Bhattacharya, A., Dong, J. Q., Fabian, N., & Haenlein, M. (2021). Digital transformation: A multidisciplinary reflection and research agenda. *Journal of Business Research*, 122, 889-901.
- Westerman, G., Bonnet, D., & McAfee, A. (2014). The nine elements of digital transformation. *MIT Sloan Management Review*, 55(3), 1-6.
- Wirtz, B. W., & Müller, W. M. (2019). An integrated artificial intelligence framework for public management. *Public Management Review*, 21(7), 1076-1100.

## Game Theory Application for European Photonics Companies Collaborating with Asian EDA Firms to Develop EDA Tools

Terence S.-Y. Chen <sup>1,\*</sup>

\*Corresponding author

<sup>1</sup> University HEC Liège Executive Education, Management School- Liège Université, Belgium, Executive Doctorate in Business Administration (EDBA), Student, terence2045@gmail.com

### ABSTRACT

This paper proposes a game theory approach to analyze the potential for collaboration between European photonics companies and Asian Electronic Design Automation (EDA) firms in developing EDA tools. The study aims to provide insights into the dynamics of cooperation and competition between these two regions, which can help companies operating in the global photonics industry. The research will examine the challenges faced by small European companies in the photonics industry's supply chain in Asia and how collaboration with Asian EDA companies can improve Europe's mastery of EDA technology and boost its photonics industry. The paper will also explore how partnerships with Asian EDA companies can improve Europe's supply chain security and global competitiveness in photonics.

*Keywords:* Game theory, EDA, photonics, supply chain.

### INTRODUCTION

The semiconductor photonics sector is a highly competitive global market, where small European companies face significant challenges due to local talent shortages and insufficient investment. To maintain their competitiveness, these companies need access to advanced technology and resources that can help them develop Electronic Design Automation (EDA) tools. Collaboration with Asian EDA firms is one way for European photonics companies to gain such access. However, cooperation between these two regions is not without its challenges, including issues related to intellectual property rights, cultural differences, and language barriers.

This research aims to examine the complexity of European photonics industry's supply chain in Asia, the role of small European companies in EDA development for semiconductor photonics, and the influence of collaboration with Asian EDA companies on European competitiveness and supply chain security in photonic industry.

The key research questions addressed in this study are:

1. What is the current state and potential of European EDA tools in global photonics market?
2. What factors determine how the access to European foundries affects the EDA supply chain in European photonics industry?
3. What challenges does Europe face in photonics innovation due to the lack of local talent and investment?
4. What opportunities arise from the cooperation with Asian EDA companies that could improve Europe's mastery of EDA technology and boost its photonics industry?
5. In what ways can partnerships with Asian EDA companies improve Europe's supply chain security and global competitiveness in photonics?

To address these challenges, this paper proposes a game theory approach to analyze the potential for collaboration between European photonics companies and Asian EDA firms in developing EDA tools. Game theory provides a framework for understanding the dynamics of cooperation and competition between these two regions, which can help companies operating in the global photonics industry. The study aims to provide valuable insights into maintaining competitiveness against large US EDA firms while enhancing Europe's supply chain security and global competitiveness in photonics.

By applying game theory modeling and analysis, this study aims to provide the following specific insights:

- Identify potential mutually beneficial collaboration opportunities between European photonics SMEs and Asian EDA companies. The analysis will explore scenarios where strategic alliances can enhance access to technology and resources for European firms while expanding market reach for Asian firms.
- Elucidate the competitive dynamics between players and determine optimal strategies for cooperation and competition. The modeling will examine factors that incentivize or deter collaboration and suggest approaches to overcome barriers.
- Evaluate the payoffs and risks associated with different strategic decisions like mergers, partnerships, or in-house development. This can guide companies in choosing strategies aligned with their objectives.
- Understand the influence of critical factors like intellectual property rights, cultural differences, and alignment of strategic goals on alliance success. The analysis will provide ideas for managing these factors.

- Assess the impact of potential alliances on competitiveness against large US EDA firms and supply chain security. This can demonstrate how international collaboration can strengthen the position of European photonics SMEs.

By applying game theory techniques, this research aims to uncover actionable strategic insights for photonics companies seeking growth opportunities through global alliances and partnerships. The analysis intends to provide a nuanced perspective into the dynamics at play in this competitive cross-continental industry.

### LITERATURE REVIEW

The literature review is organized into three paragraphs on the photonics industry in Europe, supply chain disruption and resilience, and the application of game theory.

Towards the end of the 20th century, photonics began to gain significant attention from academia and industry. Inniss and Rubenstein (2016) provide an overview of silicon photonics, detailing its history, market opportunities, and prospects. Ozkan-Canbolat et al. (2016) highlight increasing importance of bandwagon pressure and evolutionary game theory in driving strategic innovation in photonics industry. The seminal work of Chrostowski & Wim (2018) highlighted significance of EDA tools for burgeoning silicon photonics technology. Lipson (2022) explores revolutionary impact of silicon photonics, emphasizing its success in enabling groundbreaking research areas and applications. The current study intends to employ game theory as a tool for examining possible collaborative landscape between European photonics companies and Asian EDA firms. It seeks to contribute to evolving discourse on how smaller European photonics companies can enhance their competitiveness in global market predominantly occupied by larger entities. The study also aspires to illuminate how such collaborations can strengthen Europe's supply chain security and improve its global standing in photonics industry. This could mark significant step forward in our understanding of intricate interplay of photonics, EDA, and game theory. Furthermore, study will also contribute to ongoing debate on how small-to-medium enterprises (SMEs) can enhance their competitiveness against larger players. Recent literature has highlighted need for SMEs to form strategic alliances and harness external resources to compete effectively (Zahoor et al., 2023). By analyzing potential collaboration between European photonics companies (primarily SMEs) and Asian EDA firms, study will provide valuable insights into how SMEs can leverage international partnerships to improve their competitive position.

Researchers have grappled with the complexities of international collaborations. Rugman and Collinson (2005) elucidated the specific challenges faced by smaller European firms venturing into Asian markets. Cultural and language barriers were identified as substantial obstacles in their study. Agrawal et al. (2021) presented findings from a systematic literature review on supply chain resilience and disruptions. Their study created a framework of resilience strategies with the goal of reducing the negative impact of disruptions on the photonics industry. They employed data visualization techniques to facilitate understanding and decision-making. Through visualizing complex data, decision-makers can obtain a comprehensive view of supply chain dynamics and proactively implement strategies to foster resilience and ensure the smooth functioning of the photonics industry. Attinasi et al. (2021) expanded our understanding of the impact of supply chain disruptions on the global economy. They focused on ongoing supply disruptions and provided an empirical assessment of their impact on global economic activity and prices. Their analysis of disruptions' effects on economic indicators offered insights into the wider effects of supply chain disruptions beyond the photonics industry, emphasizing the need for robust strategies to counteract the adverse effects of disruptions. Katsaliaki et al. (2022) offered a comprehensive review of the literature on supply chain disruptions and resilience. By synthesizing existing information, they illuminated the different types of disruptions, their impact on supply chains, and the resilience methods and recovery strategies used to mitigate their effects. Their study also proposed a future research agenda, suggesting areas that require further exploration to enhance supply chain resilience in the photonics industry. In light of recent escalation in geopolitical tensions and supply chain disruptions, importance of supply chain security has been underscored in academic literature (Dowgiewicz, 2022). Potential of strategic collaborations to bolster supply chain security is an aspect that is yet to be thoroughly explored. This research intends to shed light on this issue by analyzing potential benefits and challenges of collaboration between European photonics companies and Asian EDA firms. Suominen et al. (2023) further amplified this dialogue by exploring the issue of intellectual property protection in cross-border collaborations.

The application of game theory to the analysis of business collaborations has been championed by Jervis (1988), who conceptualized companies as 'players' with distinct informational advantages and varying motivations. The co-opetition concept introduced by Bengtsson & Kock (2000) endorsed the idea that companies could operate in a state of simultaneous competition and collaboration. Chen and Fan (2006) utilized game theory to find stable solutions and provide theoretical foundations for strategic alliances. Their research advances our understanding of the dynamics of strategic alliances and offers valuable insights into the formation of stable and mutually beneficial partnerships. Later, Daidj & Hammoudi (2017) made a valuable contribution to the literature by using game theory to elucidate the rational process of decision-making in the corporate management and market competition framework. They elaborated on the concepts and logical structure of reasoning offered by game theory and explored its applications. Additionally, they explored the notion of "coopetition," which involves the simultaneous pursuit of cooperation and competition among firms. More recently, researchers have leveraged game theory to analyze the nuances of technology collaborations specifically. A groundbreaking study by Nguyen (2020) implemented a game theory model to interpret the dynamics of cooperation between companies operating in distinct technological domains. In another notable research, Han et al. (2021) applied game theory principles to study the collaboration dynamics between Chinese and Western tech companies, providing valuable insights into potential barriers and proposing strategies for effective collaboration. The proposed study aims

to contribute a new perspective to the research on international collaborations, particularly within the high-tech industry. While numerous studies have analyzed the challenges of cross-border collaboration, few have specifically investigated the European photonics and Asian EDA industries. The present study will fill this research gap, providing unique insights into the dynamics of this under-studied international partnership. By employing a game theory approach, the study aims to contribute a new analytical tool to the academic discourse on international collaborations, potentially opening avenues for further research in this field.

### RESEARCH METHOD

Given the multi-disciplinary and nuanced nature of the topic, the research will employ a mixed-methods approach, drawing upon archival research, comparative case study analysis, and game theory modeling. The chosen methodology aims to explore the strategic dynamics between European photonics companies and Asian EDA firms, investigating the potential for collaboration and competitiveness within the current business landscape.

A comprehensive review of existing literature and secondary data sources will be conducted. This will include academic articles, industry reports, company documents, and other relevant publications. The aim is to garner a solid understanding of the evolution and current state of the photonics and EDA industries, as well as the application of game theory within these contexts. This step will serve as the foundational base of our research, informing and guiding the subsequent stages of investigation.

A semi-structured interview approach will be utilized to gather insights from key individuals within the chosen companies, enabling a deeper understanding of the firms' strategic behaviors and operational dynamics with selected European photonics companies and Asian EDA firms. This qualitative method will enrich the research by offering specific, nuanced insights that go beyond purely quantitative measures.

Drawing upon the insights gleaned from the archival research and case studies, game theory modeling will be applied to simulate potential strategic interactions between the European photonics companies and Asian EDA firms. The objective is to explore possible collaboration scenarios, analyze competitive dynamics, and evaluate potential outcomes of strategic decisions. Various models will be considered to reflect different situations of cooperation, competition, and co-opetition.

The analysis of the data will be conducted in a primarily qualitative manner, focusing on the identification and interpretation of recurring themes, patterns, and strategic behaviors observed through the case studies. The game theory models will be analyzed to derive potential strategies and outcomes, providing a predictive element to the research.

#### Data Sources:

- Academic articles, industry reports, company documents - provide background on photonics and EDA industries
- Case studies of 7 companies: A, B, C, D, E, F, G (see brief profiles below)
- Semi-structured interviews with senior executives at case study companies
- Public financial data, market shares, industry metrics for quantitative analysis

#### Company Profiles:

- Company A - European SME focused on photonic IC design tools, \$3.5M revenue in 2022. Company A is a company that provides software for photonic integrated circuit design. They automate and integrate the complete photonic design flow in one platform, using Python as a standard language. They also offer training, support, and design services for their customers. Luceda Photonics was founded in 2014 and is based in Dendermonde, Belgium. They also have offices in China, North America, and Japan.
- Company B - Asian EDA firm providing electronic/photonic tools, \$2M revenue in 2022. Company B is a company that provides electronic design automation (EDA) software solutions for specialty technologies, such as silicon photonics, power ICs, and VCSEL arrays. They offer a full-flow solution called PIC Studio, which integrates design, simulation, layout, verification, and testing of photonic integrated circuits (PICs) in one platform. They also provide PhotoCAD, a layout design tool for PICs, and Power Studio, a design and simulation tool for power ICs. They have offices in China, Singapore, and Korea.
- Company C - European silicon photonics foundry, \$5.2M revenue in 2022. Company C is a company that manufactures photonic integrated circuits (PICs) for customers in high-tech areas such as communication, quantum technologies, LiDAR, and biosensors. They use silicon nitride as their core material, which has advantages such as low loss, wide transparency window, high nonlinear coefficient, and high power threshold. They also offer a complete design platform and a process design kit (PDK) for their customers. LIGENTEC was founded in 2016 and is based in Switzerland. They also have offices in China, North America, and Japan.
- Company D - European silicon photonics research foundry, \$896M revenue in 2022. Company D is an international research and development organization, active in the fields of nanoelectronics and digital technologies, with headquarters in Leuven, Belgium. Company D employs around 4,000 researchers from more than 90 countries and has numerous facilities dedicated to research and development around the world.
- Company E - European system-level simulation tool provider, \$2.5M revenue in 2022. Company E is a company that provides software and services for photonic design automation and optical equipment configuration. They offer solutions for various applications, such as optical transmission systems, photonic integrated circuits, fiber amplifiers and lasers, and specialty technologies. They have offices in Berlin, Boston, Minsk, and Shanghai.

- Company F - Global EDA company with wide portfolio, \$984M revenue in 2022. Company F is a company that provides software and services for electronic design automation, semiconductor intellectual property, and software security and quality. They are a leader in the fields of EDA, IP, and application security testing. They help customers innovate from chips to software, enabling the development of smart devices and applications.
- Company G - Asian EDA company looking to enter photonics market, \$63M revenue in 2021. Company G is a company that provides electronic design automation (EDA) software and services for integrated circuit design and manufacturing. They offer solutions for analog design, digital SoC design, flat panel display design, and foundry EDA.

Game Theory Parameters:

- Payoffs estimated from revenues, costs, market shares in case studies
- Probabilities initially based on industry knowledge, then updated using Bayes' rule during game play
- Quantitative data will complement case insights

This research methodology offers a balanced and comprehensive approach to the study, providing the necessary depth and breadth to understand the strategic landscape of the European photonics and Asian EDA industries, as well as the potential of game theory as a tool to analyze their interactions and collaborations.

## RESEARCH STEPS

### Preliminary Research & Data Collection

The first step will involve gathering relevant data sources that provide insights into the photonics industry in Europe and the EDA industry in Asia. Academic articles, industry reports, company documents, and other relevant publications will be collected for review. This stage is fundamental to creating a solid knowledge base about the industries, the potential for collaboration, and the application of game theory in these contexts. Following the preliminary research, we will summarize those representative companies from the European photonics and Asian EDA industries for the case studies. The companies will be summarized based on factors such as their product portfolio, and past strategic alliances. The summary is shown in table 1.

Table 1: Summary of major players in photonics EDA market

Company	Role in Photonics Industry	Product Portfolio	Past Strategic Alliances	Past Strategies
Company A	European SME EDA Company	Layout tools, but interested in expanding into Schematic-Driven Layout (SDL)	Collaborated with European top universities and foundries	Concentrated on photonics layout tool and did not initially plan to expand tool chain
Company B	Asian EDA Company	Full-flow EDA tool chains, SDL, photonic circuit simulator	Collaborated with local customers in Asia, customized tools to meet local needs	Developing electronic and photonic tool chain independently without looking for alliance in Europe
Company C	Swiss Photonics Foundry	Provides infrastructure for photonics manufacturing	Collaborated with European academic users	Served as a pilot line for academic users
Company D	Belgian Photonics Foundry	Provides infrastructure for photonics manufacturing	Worked with both European and Asian photonics industry	Developed latest photonics manufacturing techniques and received funding from European and Asian customers outsourcing new product manufacturing
Company E	European System-Level Simulator	System-level photonics simulation tools	Worked with US EDA company for the on-chip circuit design and European universities to develop the latest system level simulation tools	Kept a high price for their system level simulation tool
Company F	Global EDA Company	Wide range of EDA tools, including those for photonics	Multiple acquisitions of SMEs in the photonic EDA field	Provided full-flow solutions in every field, including analog, digital and mixed-signal design automation from component to system
Company G	Asian EDA Company	Primarily electronic design automation	Collaborated with Asian fabless design	Build a full flow for analog integrated circuit

		tools, interested in entering photonics EDA	companies to serve their specific needs	design and partial digital integrated circuit design
--	--	---	---	--

Source: This study.

### Case Study Research

Semi-structured interviews will be carried out with key individuals within the chosen companies, aiming to understand their strategic decision-making processes, views on collaboration, competitive dynamics, and challenges faced in the industry. Each case study will also examine the companies' histories, past and present strategic alliances, market performance, and other relevant factors. The result from the interview is summarized in table 2.

Table 2: Interview with major players in photonics EDA market

Company	Position	Key Interview Insights
Company A	CEO	Company A is seeking strategic alliances to expand its product portfolio, specifically by adding a SDL tool. They are open to collaboration but are concerned about intellectual property rights and are eager to maintain their foothold in the European market.
Company B	CTO	Company B is confident in its established presence in Asia and is currently developing a full-flow platform for component to system-level design automation. The company is actively seeking collaborations within the local Asian photonics industry and looking for expanding their sells into Europe.
Company C	Head of Strategic Alliances	Company C is a foundry planning to expand its market reach to Asia. They are open to alliances with Asian EDA companies, but their focus is to maintain their position in the European market.
Company D	Director of Business Development	Company D is also a foundry looking to expand, but their primary interest lies in the U.S. market. They are exploring potential alliances with global EDA companies.
Company E	Chief Product Officer	Company E expressed that they are looking for ways to expand in the Asian market while maintaining a high price for their system-level simulation tool. They are open to alliances to strengthen their market position.
Company F	Executive VP of Sales and Marketing	Company F is focused on expanding its dominance in the EDA market. The company expressed openness to strategic alliances but remains wary of potential competition from rising SMEs.
Company G	Head of R&D	Company G is eager to move into the photonic design automation market. They are keen on competing with Company B in the Asian market and are seeking potential alliances with European photonics companies to strengthen their photonics knowledge.

Source: This study.

### Game Theory Modeling

In this research, we use Bayesian games that deal with scenarios of incomplete information, where players have private information (their 'types') that the other players do not know. Players then have beliefs about the possible types of the other players, represented by a probability distribution over the set of possible types. Bayesian games are used when strategic interactions involve uncertainty about the other players' private information. In our scenario, there's uncertainty about the level of proficiency in commercial EDA software development of the different companies, hence the choice to model this as a Bayesian game. The primary advantage of Bayesian games is that they can model strategic interaction under uncertainty. They allow for the analysis of how players' strategies can depend on their private information and their beliefs about the other players' private information. We can extract several key pieces of information to perform a Bayesian game model:

- Players: The companies (A through G) involved in the photonics industry. Each company has its own interests and strategies.
- Actions: The companies can choose to form alliances (strategic collaborations), develop new products, expand into new markets, or do nothing.
- Types: Each company has a "type", which can be interpreted as its current role in the photonics industry, its product portfolio, and its past strategic alliances and strategies.



- Payoffs: The payoff for each company is determined by the action it takes, the type of the company it interacts with, and the actions taken by the other companies.
- Beliefs: Each company has beliefs about the other companies' types and the actions they are likely to take.

The Bayesian game model could proceed as follows:

- Beliefs Formation: Each company forms beliefs about the other companies' types and the actions they are likely to take. These beliefs are updated as the game progresses, based on the actions taken by the companies and the information revealed by those actions.
- Action Choices: Each company chooses an action based on its beliefs and its payoff function.
- Payoff Realization: After all companies have chosen their actions, payoffs are realized.

We formalize the Bayesian game model in a mathematical sense, let's first define the players, actions, types, payoffs, and beliefs more concretely. The players and types are summarized in table 3 and the summary of possible actions are summarized in table 4.

Table 3: Players and types

Player	Type
A	European SME EDA Company
B	Asian EDA Company
C	Swiss Photonics Foundry
D	Belgian Photonics Foundry
E	European System-Level Simulator Company
F	Global EDA Company
G	Asian EDA Company

Source: This study.

Table 4: Possible actions

Actions	Description
Form Alliance	Company seeks strategic alliances with another company
Develop New Product	Company focuses on developing new products
Expand Market	Company aims to expand to new markets
Maintain Status	Company continues current strategy and maintains its position

Source: This study.

Next, we define the payoff function. Let's denote the payoff function of player  $i$  as  $u_i(a, \theta)$ , where  $a$  is the action taken and  $\theta$  represents the type of the player. The exact form of the payoff function would depend on the specific details of the situation, which we do not have. However, we can say that the payoff function would depend on the action taken by the company, the type of the company, and the actions taken by other companies. For example, the payoff from forming an alliance would be higher if the alliance is successful and the other company is a good match in terms of technology and market reach. Finally, we define the beliefs. Let's denote the belief of player  $i$  about player  $j$ 's type as  $b_{ij}(\theta_j)$ . This belief is updated based on the actions taken by player  $j$  and the information revealed by those actions. Given this setup, each company chooses an action to maximize its expected payoff, taking into account its beliefs about the other companies' types and actions. Mathematically, this can be represented as:  $\max_a E [u_i(a, \theta) | b_i(\theta)]$ , where the expectation is taken over the beliefs about the other companies' types. The equilibrium of the Bayesian game is a set of strategies (one for each company) such that no company can improve its expected payoff by unilaterally changing its strategy. This is known as a Bayesian Nash equilibrium.

In Bayesian game theory, probabilities play a key role in representing the uncertainty about the types of other players and the actions they might take. When players form beliefs about the types of other players, these beliefs are represented as probability distributions over the set of possible types. To incorporate this into the model, let us denote the probability that player  $i$  assigns to player  $j$  being of type  $\theta_j$  as  $b_{ij}(\theta_j)$ . The companies then choose actions to maximize their expected payoff, where the expectation is taken with respect to these probability distributions. This can be represented mathematically as:  $\max_a \sum_{\theta} b_i(\theta) u_i(a, \theta)$ , where the sum is taken over all possible types, and  $u_i(a, \theta)$  is the payoff of player  $i$  when it takes action  $a$  and the other players are of type  $\theta$ . The equilibrium concept used in Bayesian games is the Bayesian Nash equilibrium, which is a strategy profile (a strategy for each player) such that no player can increase its expected payoff by unilaterally deviating from its strategy, given its beliefs about the other players' types and the strategies they are playing. Continuing with the Bayesian game model and incorporating probabilities, we need to define the beliefs of each company about the types and potential actions of the other companies. The exact probabilities would depend on the specifics of the situation, which we don't have, but we can discuss how they would be incorporated into the model. Each company  $i$  has a belief  $b_{ij}$  about the type of each other company  $j$ . These beliefs can be represented as probability distributions over the set of possible types. The companies also have beliefs about the actions that the other companies are likely to take, given their types. These beliefs can be updated based on the actions that the companies observe each other taking. Given these beliefs, each company  $i$  chooses an action  $a_i$  to maximize its expected payoff, considering its beliefs about the types and actions of the other companies. The expected payoff of company  $i$  when it chooses action  $a_i$ , given its beliefs, can be represented mathematically as:

$E[u_i(a_i, \theta_j) | b_{ij}] = \sum_{\theta_j} b_{ij}(\theta_j) u_i(a_i, \theta_j)$ , where the sum is over all possible types  $\theta_j$  of company  $j$ , and  $u_i(a_i, \theta_j)$  is the payoff of company  $i$  when it chooses action  $a_i$  and company  $j$  is of type  $\theta_j$ .

The equilibrium of the game is a Bayesian Nash equilibrium, which is a set of strategies (one for each company) such that no company can increase its expected payoff by unilaterally deviating from its strategy, given its beliefs about the other companies' types and actions. Mathematically, a strategy profile  $(a_i^*)$  for all  $i$  is a Bayesian Nash equilibrium if for all companies  $i$  and all actions  $a_i$ :

$$E[u_i(a_i^*, \theta_j) | b_{ij}] \geq E[u_i(a_i, \theta_j) | b_{ij}] \quad (1)$$

That is, no company  $i$  can increase its expected payoff by changing its action from its equilibrium action  $a_i^*$  to some other action  $a_i$ , given its beliefs  $b_{ij}$  about the types and actions of the other companies.

### Analysis and Interpretation

The Bayesian game model is constructed step-by-step as follows:

- Players - The 7 companies (A-G) are the players, each with unique strategic goals based on their role and position in the photonics industry.
- Actions - The possible moves for each player are modeled - forming alliances, developing new products, expanding markets, or maintaining status quo. This covers the major strategic options available.
- Types - The type of each player encompasses their current capabilities and resources, which is private information unknown to others initially.
- Beliefs - Players have initial beliefs about others' types based on industry knowledge. These beliefs are updated using Bayes' rule as moves reveal new information.
- Payoffs - Payoffs for actions are quantified using revenue, cost, and market share data from the case studies. For example, the payoff for a successful alliance includes benefits like increased revenue, net of costs like R&D spending.
- The companies then repeatedly interact, choosing actions to maximize expected payoffs based on updated beliefs. The model converges to a Bayesian Nash equilibrium.

Given the information available and the analysis performed so far, we can offer the following interpretations:

- Company A is looking to expand its product portfolio by adding SDL tool through strategic alliances. However, it is concerned about intellectual property rights and wants to maintain its stronghold in the European market. Considering its past strategy and its potential payoffs from alliances, Company A could potentially benefit from forming alliances with a company like Company F, a global EDA company with a wide range of EDA tools. This could provide Company A with the resources it needs to expand its portfolio while protecting its intellectual property rights.
- Company B has a strong presence in Asia and is looking to expand into Europe. With its full-flow EDA tool chains and photonic circuit simulator, it could potentially benefit from an alliance with Company C or Company D, both of which have collaborated with European and Asian photonics industries in the past and could provide a conduit for Company B to expand its market reach.
- Company C is looking to expand its market reach to Asia. An alliance with an Asian EDA company like Company B or Company G could help Company C expand its market reach while also benefiting from the respective strengths of these companies.
- Company D is primarily interested in the U.S. market. It could potentially benefit from an alliance with Company F, a global EDA company that can provide resources and support for Company D's expansion into the U.S. market.
- Company E is looking to expand into the Asian market while maintaining a high price for their system-level simulation tool. An alliance with an Asian EDA company like Company B or Company G could be beneficial for Company E.
- Company F is focused on expanding its dominance in the EDA market. It could potentially benefit from forming alliances with companies that are looking to expand their product portfolios or market reach, such as Company A, Company D, or Company E.
- Company G is looking to enter the photonic design automation market and compete with Company B in the Asian market. It could potentially benefit from an alliance with a European photonics company like Company A or Company C to strengthen its photonics knowledge.

However, it's important to note that the success of these strategic alliances will depend on several factors, including the alignment of strategic objectives, the effective management of intellectual property rights, and the ability to successfully integrate and leverage each other's resources and capabilities. Moreover, the probabilities of success are not readily available and would need to be estimated based on the specific circumstances and dynamics of each potential alliance.

### Discussion

In our analysis, several key points emerge:

- Strategic Fit: The alignment of strategic objectives among these companies is crucial to the success of any potential alliances. Companies A, B, C, D, E, F, and G each have their own strategic goals and market focus. Forming alliances with companies that share similar strategic objectives can enhance the chances of success and mutual benefits.

- **Resource Compatibility:** The compatibility of resources and capabilities among these companies also plays a significant role in the potential success of alliances. For instance, Company A's interest in expanding into SDL and Company F's wide range of EDA tools, including those for photonics, indicate a high degree of resource compatibility.
- **Geographical Considerations:** The geographic market focus of these companies is another important consideration. Companies B and G have a strong presence in the Asian market and are looking to expand their reach, while Companies A, C, and E are more focused on the European market. Understanding the market dynamics and consumer preferences in these regions can help these companies make more informed decisions about potential alliances.
- **Intellectual Property Rights:** Companies A and F have expressed concerns about intellectual property rights. It's important that any alliances formed respect and adequately manage these rights to prevent potential disputes and ensure that all parties benefit from the alliance.
- **Industry Dynamics:** The photonics industry is characterized by rapid innovation and fragmentation, with many small players focusing on specialized niches. This creates opportunities for synergistic combinations or partnerships, but also poses challenges in terms of competition and the need for continuous innovation.
- **Risk Considerations:** While alliances can offer significant benefits, they also entail risks. The success rate of alliances in the photonics industry is not readily available and would depend on a range of factors including the ones discussed above. Therefore, companies should carefully assess the potential risks and benefits before entering into alliances.

While there are potential benefits to be gained from strategic alliances among Companies A, B, C, D, E, F, and G, these companies need to carefully consider the alignment of strategic objectives, resource compatibility, geographical market focus, intellectual property rights, industry dynamics, and risk considerations before pursuing such alliances.

### CONCLUSION

This study makes several key contributions to the understanding of strategic alliances and game theory applications for technology collaborations. The analysis provides data-driven insights into beneficial partnerships, growth opportunities, competitive dynamics, and success factors for photonics companies seeking global expansion.

By leveraging comparative case studies and Bayesian game theory techniques, this research elucidates the nuances of cooperation and competition facing European and Asian firms in this industry. The modeling quantifies the impact of critical variables like strategic alignment and intellectual property management on alliance outcomes.

The findings advance academic discourse on international collaboration strategies, highlighting how synergistic cross-continental partnerships can strengthen market reach and supply chain resilience. This provides a foundation for further research into the drivers and barriers for global strategic alliances using game theory.

There are limitations in precisely estimating model parameters due to data availability challenges. Future efforts could focus on refining the payoffs and probability inputs through surveys and statistical modeling. Additionally, a dynamic analysis investigating how alliance strategies evolve over time could provide richer insights.

This study makes important strides in unraveling the complex dynamics of cooperation and competition in the global photonics industry. The integrated application of case research and game theory provides a multidimensional perspective into the interplay of factors driving international alliance decisions and outcomes. By illuminating win-win partnerships, this research aims to provide guidance to managers navigating the intricacies of strategic relationships across technological and geographical boundaries.

### REFERENCES

- Agrawal, N., & Jain, R. K. (2021). Insights from systematic literature review of supply chain resilience and disruption. *Benchmarking: An International Journal*. Ahead-of-print. <https://doi.org/10.1108/BIJ-02-2021-0084>
- Attinasi, M. G., et al. (2021). Supply chain disruptions and the effects on the global economy. *ECB Economic Bulletin, Issue 8/2021*. [online] Available: [https://www.ecb.europa.eu/pub/economic-bulletin/focus/2022/html/ecb.ebbox202108\\_01~e8ceebe51f.en.html](https://www.ecb.europa.eu/pub/economic-bulletin/focus/2022/html/ecb.ebbox202108_01~e8ceebe51f.en.html) [Accessed 5 May 2023].
- Bengtsson, M., & Kock, S. (2000). "Coopetition" in Business Networks—to Cooperate and Compete Simultaneously. *Industrial Marketing Management*, 29(5), 411-426. [https://doi.org/10.1016/S0019-8501\(99\)00067-X](https://doi.org/10.1016/S0019-8501(99)00067-X)
- Bogaerts, W., Chrostowski, L. (2018). Laser & Photonics Reviews, 12, 1700237. <https://doi.org/10.1002/lpor.201700237>
- Chen, F. q., & Fan, L. c. (2006). Analysis on stability of strategic alliance: A game theory perspective. *J. Zhejiang Univ. - Sci. A*, 7, 1995–2001. <https://doi.org/10.1631/jzus.2006.A1995>
- Dowgiewicz, Kevin. (2022). *How technology can advance port operations and address supply chain disruptions*. Theses and Dissertations. 1265. <https://digitalcommons.pepperdine.edu/etd/1265>
- Hammoudi, A., & Daidj, N. (2017). *Game Theory Approach to Managerial Strategies and Value Creation*. Wiley-ISTE.
- Han, W., et al. (2021). The trade-off between trust and distrust in supply chain collaboration. *Industrial Marketing Management*, 98, 93-104. <https://doi.org/10.1016/j.indmarman.2021.08.005>
- Inniss, D., & Rubenstein, R. (2016). Silicon Photonics: Fueling the Next Information Revolution. *Elsevier*.
- Jervis, R. (1988). Realism, Game Theory, and Cooperation. *World Politics*, 40(3), 317-349. <https://doi.org/10.2307/2010216>

- Katsaliaki, K., Galetsi, P., & Kumar, S. (2022). Supply chain disruptions and resilience: a major review and future research agenda. *Annals of Operations Research*, 319(1), 965-1002. <https://doi.org/10.1007/s10479-021-04287-y>
- Lipson, M. (2022). The revolution of silicon photonics. *Nature Materials*, 21(9), 974-975. <https://doi.org/10.1038/s41563-022-01363-6>
- Nguyen, K., et al. (2020). The Impact of Business Strategy on Firm Performance of Listed Firms in Vietnam. *VNU Journal of Economics and Business*, 36, Dec. 2020. ISSN 2734-9845.
- Ozkan-Canbolat, E., et al. (2016). Application of Evolutionary Game Theory to Strategic Innovation. *Cankiri Karatekin University, Cankiri, 18000, Turkey*.
- Rugman, A. M., & Collinson, S. (2005). Multinational Enterprises in the New Europe: Are They Really Global? *Organizational Dynamics*, 34, 258-272.
- Suominen, A., Deschryvere, M., & Narayan, R. (2023). Uncovering value through exploration of barriers: A perspective on intellectual property rights in a national innovation system. *Technovation*, 123, Article 1027191.
- Zahoor, N., Al-Tabbaa, O., & Khan, Z. (2023). R&D alliances and SMEs post-entry internationalization speed: The impact of alliance management capability and co-innovation ambidexterity. *Global Strategy Journal*, 1–34. <https://doi.org/10.1002/gsj.1481>.

## Gen Z Consumers' Purchase Intention Towards Organic Cosmetic Brands Advertised on Social Media

Sarita Nagvanshi<sup>1,\*</sup>  
Neha Gupta<sup>2</sup>  
Vinod Kumar<sup>3</sup>

\*Corresponding author

<sup>1</sup> Research Scholar, Amity University, Noida, India, sarita.nagvanshi247@gmail.com

<sup>2</sup> Assistant Professor, Amity University, Noida, India, ngupta10@gmail.com

<sup>3</sup> Professor, New Delhi Institute of Management, Delhi, India, vinodsaini6388@gmail.com

### ABSTRACT

Social media is one of the most reasonable and accessible sources of advertising which caters to a wide variety of audience and gives better results. The aim of this study is to evaluate the impact of social media advertising on Gen Z social media users' intention to purchase organic cosmetic products with the mediating role of brand awareness, brand image and brand loyalty. A sample of 310 units were collected from people born from 1997-2011. The proposed research model was tested using structural equation modeling on Smart PLS 4.0. The results of the study found that social media advertising had a significant positive impact on purchase intention and the mediating variables were partially mediating between social media advertising and purchase intention. The study will be helpful to organic cosmetic brands and marketing professionals who have an intention to use social media advertising as a marketing tool.

*Keywords:* Social media marketing, Digital Marketing, Social media Advertising, Advertising, Brand equity, Purchase intention

### INTRODUCTION

MySpace was the first social media platform to have a million active users every month; this occurred in 2004; arguably, this marks the start of social media as we know it today (Ospina, 2019). Facebook debuted the same year and quickly established itself as the industry's strongest cornerstone. Even after 18 years in operation, Facebook is still the most popular social media networking platform. A recent survey found that social media was one of the top three digital marketing platforms used globally in 2020, with 83 percent of marketing specialists using it in their digital campaigns (Statista, 2022a). Similarly, social media advertising had the second biggest market size within the digital advertising segment among other segments such as search advertising, banner advertising, video advertising, and classifieds with a spending of \$183.54 billion in 2021 which is expected to grow by 11.24% annually, with a market size of US\$384.90 billion by 2027 (Statista, 2022b). What's more intriguing is that despite the global breakout of covid-19 in 2020, social media advertising had the highest growth rate making it a pandemic-proof ad format (PwC-IAB Report, 2021). Social media advertising has not only been useful for promoting broader and older market segments, but a lot of niche segments have also benefitted. Social media platforms constitute a new setting for commercial, social, political, and educational interaction between individuals, groups, and even governments, as well as the exchange of ideas, information, goods, and services (Hawkins & Vel, 2013; Rathore et al., 2016; Usher et al., 2014). Given that most users and content creators on social media are laypeople, many brands have started adapting to users' preferred languages and communication styles by using more "authentic" content (Schnackenberg & Tomlinson, 2014).

One of the major challenges for professionals who use social media advertising for their campaigns is to find out if the ads perform in favor of their goals. It is also obvious that different campaigns may elicit different responses under various conditions. As a result, studying the social media advertising activities for individual product segments in particular regions or with customer demographics can aid in producing trustworthy and useful results. The present study focuses on examining the impact of social media ad campaigns by organic cosmetic brands on the purchase intention of Gen Z consumers. People now prefer natural and chemical-free products as they become more environmentally conscious. "Sustainability, a term that most industries are using more and more, has been responsible for the change in consumer and corporate behavior, leading to new directions for the development of raw materials and products, environment, people, and waste management, improving the application of energy resources, and improving consumer behavior" (Adams & Jeanrenaud, 2008a; Brower & Leon, 1999; Fonseca-Santos et al., 2015). Brands of organic products are utilizing this market opportunity by promoting their goods through new marketing tools such as social media marketing and advertising, influencer marketing, etc. The Soil Association, (n.d.) defines organic cosmetics as "the production of cosmetic goods using organically produced ingredients." According to the Soil Association, (n.d.) these ingredients are grown without the use of genetically modified (GM) organisms, pesticides, synthetic fertilizers, and more and are free of animal testing.

The study is unique since it examines the impact of social media advertising on the behavioral intentions of Gen Z consumers for organic cosmetic goods. Every business needs to understand how the younger generations i.e., millennials, Gen Z, and Gen Y, perceive and behave in relation to social media campaigns as they are the most active on social media. On the other hand, because of the recent rise in public awareness of environmental issues, the demand for organic products is high. This presents a chance as well as the need for in-depth research in the area. While academicians and researchers appear to be producing rigorous work in the general organic sector, more in-depth research is required to produce useful insights in smaller segments of the sector. This research gap came up with the following research questions:

RQ1: What are the factors that mediate the impact of social media advertising on the purchase intention of Gen Z for organic products?

RQ2: Is there a significant impact of social media advertising on Gen Z's purchase intention of organic products?

This study is designed to find the answers to the above-mentioned research questions and proposed a conceptual framework. The proposed conceptual framework was validated by using PLS-SEM and a survey-based research methodology. Remaining of the article is divided into the following sections. Section 2 has offered the theoretical backdrop, which goes over the literature on key research determinants. Section 3 covers the materials and study methods in great depth, whereas Section 4 covers the results. Section 5 presents the conclusion and implications of the study. Section 6 presents the limitations and future scope, followed by references.

### THEORETICAL BACKGROUND

While practitioners are eager to incorporate social media advertising into their marketing communications and advertising programs to drive digital engagement through more direct communications with their target audience, it is clear that scholars are also delving into the depths of social media advertising by focusing on the various aspects of the topic (Nasir et al., 2021). Raji et al. (2019) have been one of the base studies for this study. It investigates the influence of social media advertising content and social media sales promotion content in the development of both hedonic and functional brand image and the enhancement of customers' behavioral intentions, particularly brand preference and purchase intention. Although the results of the paper found that social media advertising content and sales promotions had a significant positive impact on both functional and hedonic brand image and had a significant indirect effect on behavioral intention, it did not prove a direct impact of social media advertising content on behavioral intention. Sari et al. (2020) presented the response of Muslim millennial parents toward social media advertising for kids' food products. It found that millennial parents found social media ads relevant and found a positive indirect impact of social media ad value on their purchase intention. Alalwan, (2018) investigated the impact of certain social media advertising features such as interactivity, habit, informativeness, perceived relevance, and performance expectancy on purchase intention and found that habit did not have an impact on purchase intention, but all other variables did have some amount of significance towards purchase intention. A study by Chetioui et al., (2021) on Facebook advertising and its relevance to purchase intention found that consumers' attitudes towards Facebook ads had about 50% impact on their intention to purchase. It also found that social media ad characteristics such as informativeness and perceived credibility can lead to an increase in e-word of mouth and perceived ad relevance and eWOM can directly influence consumers' attitudes towards Facebook ads by approximately 46%.

#### Social Media Advertising

Consumers now spend far more time on social networking sites than on other traditional media (Liu, 2014), which gives businesses the confidence to invest a lot of time and money in social media advertising to reach a larger audience (Lai & Ren, 2016). Social media advertising is described by Alhabash et al., (2017) as "any piece of online content developed with a persuasive goal and/or delivered via a social media platform that enables internet users to access, share, engage with, add to, and co-create". According to Mukherjee & Banerjee, (2017), social media advertising involves two different types of practices: i) using free tools offered by social media platforms like Facebook or tools offered by online video-sharing sites like YouTube, and ii) using paid media like Facebook paid advertisements and sponsored content in various blog posts. One of the essential qualities of social media advertising is its two-way communication nature and ability to track user replies, which assists businesses in building a strong brand (Boateng & Okoe, 2015). It is also worth noting that businesses develop and publish online marketing offerings through social media platforms to capture value by facilitating connection, and communication, and delivering tailored recommendations regarding products and services (Yadav & Rahman, 2017). Another significant advantage of advertising on social media platforms is that advertising messages may be targeted to specific audiences based on their interests and demographics (Kelly et al., 2010; Sundar & Marathe, 2010).

#### Brand Awareness

Brand awareness refers to a potential customer's capacity to recognize or recall a brand in their brains, which assists consumers in associating products with brands (Aaker, 1991). Brand awareness is also viewed as a prerequisite for brands to be included in consumers' consideration set during the decision-making process (Langaro et al., 2018), and is regarded as an important component of brand knowledge (Keller, 2016). The presence of brand awareness suggests that the consumer is familiar with the brand name, which enhances the possibility of the brand being included in a list of viable options, and hence the probability of that brand being chosen (Keller, 1993). Brand awareness consists of two components: brand recognition and brand recall (Hasan & Sohail, 2021). Brand recall is the consumer's ability to recall a brand name accurately after seeing a product category, whereas brand recognition is the consumer's ability to recognize a product when there is a brand cue (Hasan & Sohail, 2021).

***H1: Social media advertising has a significant positive impact on brand awareness.***

***H4: Brand awareness has a significant positive impact on purchase intention.***

### **Brand Image**

Brand image is defined as the concepts, perceptions, expectations, beliefs, and mental images that consumers have of a good or service by earlier scientists (Zembik, 2015). Brand image is a physical structure produced in the mind of the consumer; it is a combination of the consumer's feeling for the product and connected indirect elements (Seo & Park, 2018). Researchers like Park & Srinivasan, (1994); Homer, (2008); and Zhang, (2015) categorized brand images into functional and symbolic/hedonic brand images to acquire a comprehensive understanding of the concept. The perception of a brand's attributes, such as quality, satisfaction, and value, is referred to as functional brand image (Raji et al., 2019). Meanwhile, hedonic brand image describes the kinds of associations associated with the non-functional, emotional, or visual aspects of a brand (Park & Srinivasan, 1994; Bruhn et al., 2012). Oliver (1999) asserts that brand preferences reflect consumer loyalty behavior and aid in distinguishing between habitual brand purchases and purchases driven by the consumers' perceived and actual brand benefits. In other words, people respond to a brand by choosing it over rival brands that have a lower perceived brand image (Wu & Jang, 2014). Consumers' positive reaction to an effective brand image or brand communications like advertising and promotions is reflected in a higher purchase intention (Alford & Biswas, 2002).

***H2: Social media advertising has a significant positive impact on brand image.***

***H5: Brand image has a significant positive impact on purchase intention.***

### **Brand Loyalty**

Brand loyalty is defined by (Jacoby, 1971) as a decision-making unit's biased (non-random) behavioral response (purchase) over time regarding one or more alternative brands from a group of brands, as a consequence of psychological processes. Brand loyalty also results in a proclivity to spend more for the desired brand even when other competitive brands are available, as well as a proclivity to suggest the same brands to others (Hasan & Sohail, 2021). Brand loyalty is critical for the success and implementation of marketing strategies and associated studies (Chaudhuri & Holbrook, 2001). Brand loyalty consists of both behavioral and attitudinal factors (Jacoby & Kyner, 1973). Behavioral loyalty refers to repeat brand purchases (Li et al., 2020) whereas attitudinal loyalty refers to a consumer's favorable attitude toward a brand (Cossío-Silva et al., 2016).

***H3: Social media advertising has a significant positive impact on brand loyalty.***

***H6: Brand loyalty has a significant positive impact on purchase intention.***

### **Purchase Intention**

Purchase intention is one of the most notable markers of the efficacy of advertising ( Dao et al., 2014; Zhang & Mao, 2016; Arora & Agarwal, 2020). The ability of consumers to make purchases in the near future is known as purchase intention (Salisbury et al., 2001; Zarrad & Debabi, 2012). According to earlier research (Mukherjee & Banerjee, (2017); Wang et al., (2012); and Xu et al., (2009)) attitudes regarding internet and social media advertisements positively predict purchase intention. It's logical to assume that people who have positive views about organic cosmetic brands on social media will be more likely to actively engage with their advertising messages and become potential customers.

***H7: Social media advertising has a significant positive impact on purchase intention.***

The above-mentioned proposed hypotheses are contained in a conceptual model that has been developed because of a thorough examination of the literature (Figure 1). The proposed model consists of the direct as well as the indirect relationship between social media advertisements and purchase intention. The model also tests the mediation effect of brand awareness, brand image, and brand loyalty on the relationship between social media advertising and purchase intention. This study aims to test the proposed model on Gen Z social media users and their behavioral intention toward social media ads by organic cosmetic brands.



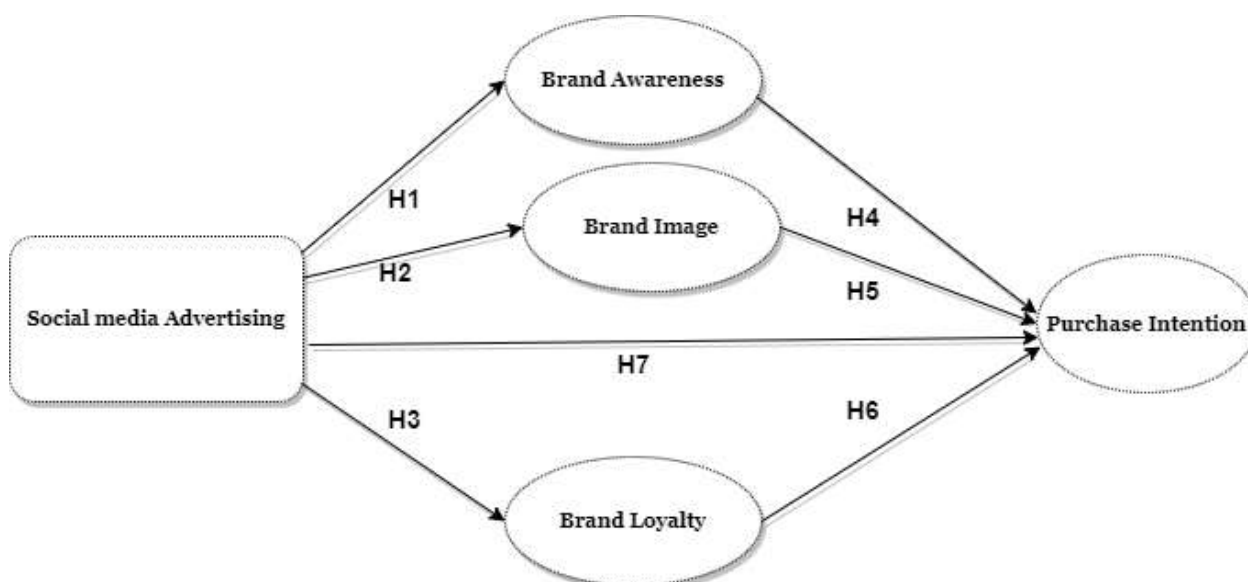

Figure 1: Research framework

### MATERIALS AND METHODS

The influence of social media advertising by organic cosmetic brands on consumers' purchase intentions was investigated using a descriptive and empirical research approach. To comprehend both direct and indirect effects, the mediation of brand awareness, brand image, and brand loyalty was also investigated. An in-depth examination of the ability of social media advertising to persuade social media users to adopt brand-related behaviors is the goal of this study (Jiménez-Castillo & Sánchez-Fernández, 2019). For this, an empirical study was carried out with participants from New Delhi, India. The ideal technique to get information for studies incorporating online platforms is through Google forms or an online survey (Cobanoglu & Cobanoglu, 2003). Therefore, the respondents were surveyed using a structured online form (Google Forms) that was distributed to them via social media sites such as WhatsApp, Instagram, and Facebook. There were two sections in the questionnaire. The demographic information of the respondents was covered in the first section, and the second half had 17 items that were assessed on a 5-point Likert scale from 1-strongly disagree to 5-strongly agree. Snowball sampling, a non-probability sampling technique was used for selecting 310 respondents belonging to the Gen Z age group i.e., people born in or after 1997 to 2011. A summary of the participants is provided in Table 1. The survey items were borrowed from earlier studies and were reframed to fit the demands of the study. 45 respondents—31 female and 14 males—were used for the survey's pilot study. Based on pilot testing and expert advice, the survey instrument's phrasing and statement order were modified. The survey instrument's Cronbach's alpha value ( $\alpha$ ) of 0.901 demonstrated its dependability (Hair et al. 2017).

Table 1: Respondent demographics

Category	Description	Frequency	Percentage
Gender	Female	173	55.8%
	Male	137	44.2%
Education	High school diploma or less	34	11%
	Bachelor's degree	160	51.6%
	Master's degree	116	37.4%
Employment	Student	171	55.2%
	Working	104	33.6%
	Unemployed	24	7.7%
	Others	11	3.5%

## RESULTS

### Measurement Model

For evaluating the reflecting measurement model, the indicator loadings, internal consistency reliability, convergent validity, and discriminant validity were computed using the consistent PLS Algorithm (PLSc) (Hair et al., 2019). All the indicators were verified by the assumption that indicator loadings of more than 0.5 are acceptable (Hulland, 1999; Truong & Mccoll, 2011), and only those with loadings higher than 0.5 were kept for the study. As shown in Table 2, two indicators, BI1 (brand image) and PI1 (purchase intention) were removed due to weak loadings.

Table 2: Indicator loadings and assessment of Construct Reliability and Convergent validity

Construct	Item	Indicator Loadings	Cronbach's alpha (>0.7)	Composite reliability (rho_a) (>0.7)	Composite reliability (rho_c) (>0.7)	Average variance extracted (AVE) (>0.50)
Social media advertising	SMA1	0.816	0.897	0.901	0.924	0.708
	SMA2	0.861				
	SMA3	0.866				
	SMA4	0.848				
	SMA5	0.813				
Brand image	BI1	Removed	0.737	0.74	0.883	0.791
	BI2	0.899				
	BI3	0.88				
Brand awareness	BA1	0.894	0.873	0.873	0.922	0.798
	BA2	0.895				
	BA3	0.892				
Brand loyalty	BL1	0.824	0.796	0.8	0.88	0.71
	BL2	0.876				
	BL3	0.827				
Purchase intention	PI1	Removed	0.844	0.845	0.928	0.865
	PI2	0.933				

PI3 0.927

To assess the construct's reliability, Cronbach's alpha ( $\alpha$ ), Roh A, and Composite reliability values were employed. The recommended threshold for Composite reliability and Cronbach's alpha ( $\alpha$ ) is 0.7 (Bland & Altman, 1997). The reliability measure Roh A is believed to be the best choice for assessing construct reliability which should have a threshold limit of 0.7 (Dijkstra & Henseler, 2015; Hair et al., 2019). Composite reliability (C.R.) rating greater than 0.95, according to Diamantopoulos et al., (2012) and Drolet & Morrison, (2001), is seen as problematic since it indicates data redundancy. The convergent validity of the construct was evaluated based on the Average Variance Extracted (AVE), where an AVE above 0.50 is regarded acceptable (Hair et al., 2019).

The discriminant validity of the construct was examined using the Fornell-Lacker criterion (Table 3) and the Heterotrait-Monotrait ratio (HTMT) criterion (Table 4). Table 3 demonstrates that the latent construct variance for its indicator (provided in bold) successfully conformed to the construct discriminant validity and was higher than that for other latent constructs (Sarr & Ba, 2017). Henseler et al., (2015) claim that the HTMT is a more precise method of evaluating discriminant validity and that a lower limit of 0.85 is acceptable. The study's findings confirmed the discriminant validity of the constructs.

Table 3: Fornell-Larcker criterion

	Brand awareness	Brand image	Brand loyalty	Purchase intention	Social media advertising
Brand awareness	<b>0.893</b>				
Brand image	0.639	<b>0.89</b>			
Brand loyalty	0.612	0.634	<b>0.843</b>		
Purchase intention	0.713	0.649	0.666	<b>0.93</b>	
Social media advertising	0.631	0.613	0.599	0.695	<b>0.841</b>

To calculate the statistical significance of path coefficients, a bootstrapping of 5000 resamples was performed on smart pls 4.0. Standard criteria for assessing structural models include the coefficient of determination ( $R^2$ ), the strength of the effect ( $f^2$ ), the cross-validated redundancy measure ( $Q^2$ ) based on blindfolding, and the statistical significance of the path coefficients (Khan et al., 2022). The explanatory power of the model was evaluated using  $R^2$  (Shmueli & Koppius, 2011). A model was categorized as weak, moderate, or considerable using (Henseler et al., 2009) criteria of 0.25, 0.50, and 0.75.

Table 4: Heterotrait-Monotrait ratio (HTMT)

	Brand awareness	Brand image	Brand loyalty	Purchase intention	Social media advertising
Brand awareness					
Brand image	0.8				
Brand loyalty	0.734	0.826			
Purchase intention	0.829	0.824	0.811		
Social media advertising	0.712	0.749	0.702	0.797	

### Structural Model

A coefficient of determination ( $R^2$ ), the strength of the effect ( $f^2$ ), cross-validated redundancy measure ( $Q^2$ ) based on blindfolding, and statistical significance of the path coefficients are all standard criteria for structure model evaluation (Khan et

al., 2022). For testing the hypothesized relationship between latent variables, a consistent PLS bootstrap approach with 5000 resamples was used. R2 was used to assess the model's explanatory power (Shmueli & Koppius, 2011). Based on (Henseler et al., 2009) criteria of 0.25, 0.50, and 0.75, a model was classified as weak, moderate, or substantial.

A beta coefficient ( $\beta$ ) closer to one shows a strong effect, whereas a T-statistics value above 1.645 was considered significant since the study was one-tailed. A P-value over 0.05 represents an insignificant relationship between the variables. Hence, a hypothesis was accepted only if the P-value was less than 0.05.

Based on the PLS bootstrap estimates, the results of the hypothesis were indicated. The result showed that social media advertising had a positive and significant relationship with brand awareness, ( $\beta= 0.631$ ,  $P = 0.000$ , and  $T = 11.864$ ). Social media advertising had approximately 63% impact on brand awareness. Thus, H1 was supported. Social media advertising also had a strong positive impact on brand image ( $\beta= 0.613$ ,  $P = 0.000$  and  $T = 12.749$ ) and brand loyalty ( $\beta= 0.599$ ,  $P = 0.000$  and  $T = 11.302$ ). There was about 61% impact on brand image and 60% on brand loyalty. Hence, H2 and H3 were also supported by the results. H1, H2, and H3 overall represent brand equity and it is clear from the results that social media advertising has a strong positive impact on overall brand equity.

Brand awareness ( $\beta= 0.313$ ,  $P = 0.000$  and  $T = 3.955$ ), brand image ( $\beta= 0.138$ ,  $P = 0.038$  and  $T = 1.775$ ), and brand loyalty ( $\beta= 0.218$ ,  $P = 0.001$  and  $T = 3.237$ ) also had a positive direct impact on purchase intention. So, H4, H5, and H6 were supported.

Finally, H7 i.e., a direct impact of social media advertising on purchase intention ( $\beta= 0.282$ ,  $P = 0.000$ , and  $T = 4.334$ ) was also established where the effect was about 28%. Based on the results, it is concluded that all the hypotheses formulated in the study were accepted.

Table 5: Path coefficients

	H1 (SMA → BA)	H2 (SMA → BI)	H3 (SMA → BL)	H4 (BA → PI)	H5 (BI → PI)	H6 (BL → PI)	H7 (SMA → PI)
$\beta$	0.631	0.613	0.599	0.313	0.138	0.218	0.282
SD	0.053	0.048	0.053	0.079	0.078	0.067	0.065
T- stats	11.864	12.749	11.302	3.955	1.775	3.237	4.334
P-values	0.000	0.000	0.000	0.000	0.038	0.001	0.000
Conclusion	Supported	Supported	Supported	Supported	Supported	Supported	Supported

### Mediation Analysis

The mediating role of brand awareness, brand image, and brand loyalty between social media advertising and purchase intention was also confirmed through the PLS bootstrapping (Table 6). The total effect of social media advertising on purchase intention was 69.5%, out of which 28.2% was the direct effect, and the remaining 41.3% was generated through the mediators. As both the direct as well as indirect effects were significant, the mediation was partial.

Table 6: The mediating role of brand awareness, brand image, and brand loyalty

Relationship	Total effect	Direct effect	Indirect effect	Total indirect effect	Mediating effect	Conclusion

SMA -> BA -> PI			0.197		Partial mediation	Supported
SMA -> BI -> PI			0.085		Partial mediation	Supported
SMA -> BL -> PI	0.695	0.282	0.133	0.413	Partial mediation	Supported

Model fit was also examined through the standardized root mean square residual (SRMR). The recommended criteria for an SRMR of < 0.08 was met as the SRMR for the study was 0.07, which proved the model to be a good fit.

### CONCLUSION AND IMPLICATIONS

Numerous studies have been conducted to investigate consumers' attitudes toward social media advertisements and their effect on purchase intention. The interest in these subjects keeps rising, owing to the growing number of social media users and the expansion of marketing and advertising efforts in various social network platforms (Nasir et al., 2021). This study attempted to understand the impact of social media ads on the purchase intention of Gen Z social media users toward organic cosmetic brands. Brand equity-related factors such as brand awareness, brand image, and brand loyalty were taken as the mediating variables to understand the indirect impact of social media ads on customers' purchase intention. It was assumed that as the Gen Z age group is one of the most active age groups on social media, they are comparatively more aware of environmental issues due to high exposure to content and are more likely to show interest in organic products, hence, their intention to purchase might be positively impacted through social media advertising. The results supported the assumptions as it was found that social media advertising had a significant positive impact on purchase intention both directly ( $\beta=0.282$ ) as well as indirectly ( $\beta=0.413$ ) through the mediation of brand awareness ( $\beta=0.631$ ), brand image ( $\beta=0.613$ ) and brand loyalty ( $\beta=0.599$ ). Social media advertising also had a strong direct effect on brand image, brand awareness, and brand loyalty.

This research also provides substantial practical contributions. The study explores how social media ads effectively impact the purchase intention of Gen Z social media users. The results would be helpful for marketers from the organic cosmetics sector or those targeting the Gen Z customer base to understand their market better and formulate social media advertising campaigns with a clearer vision. Studies like this help marketers and professionals avoid risks before designing their ad campaigns. Yoo & Donthu, (2001) state that one of the functions of advertising is to encourage consumers to remain loyal to brands with which they are familiar which are proved by this study as well. Hence, marketers may utilize social media ads to promote loyalty and preference for their brands. The study will also be helpful for individuals or businesses interested in investing in the organic cosmetic sector. Additionally, it will be an addition to the knowledge base of researchers, academics, and scholars to have a better understanding of the area and may be helpful in their future research works as well.

### LIMITATIONS AND FUTURE SCOPE

The objectives of the study have been achieved and the theoretical model developed for the study has been proven effective. However, there are certain limitations to this study that may open new research avenues for scholars and marketers. This study has investigated a limited number of factors surrounding social media advertising, future studies can consider other factors of brand equity such as brand association, brand attitude, brand preference, etc. Future studies can also study environmental factors if they base their research on the organic or green products category. This study only examined the factors in relation to Gen Z consumers based in New Delhi, India. Future studies can also explore other age groups such as Gen Y, millennials, Gen X, or even boomers. A comparative analysis of how different age groups respond to social media ads can also be performed in future studies. This study has examined the purchase intention of social media users towards the social media ads of a single product segment i.e. organic cosmetics, future studies can explore another market/ product segment or even do a comparative study of several market segments. As the study was primarily based in New Delhi, India, it could be presenting only a fraction of the reality. Results may vary in different geographical areas based on culture, education level, income level, and other demographic differences. The current study was based on customer-based primary data, which may contain respondents' biases. An experimental study can be conducted to fill this gap in which the users' attitudes are measured before and after watching an advertisement on a social media site, similar to a study on augmented reality (AR) marketing conducted by Rauschnabel et al., (2019) in which the brand attitude was measured by addressing the difference in attitudes before and after using a mobile AR app (Arora & Agarwal, 2020). Future studies based on a single social media platform such as Facebook, Instagram, Snapchat, etc. could help make the results more practical as every social media plays a different role and has a unique user base. For example, in present times, Facebook is mostly used by older generations, whereas Instagram and Snapchat are mainly used by Gen Z, late millennials, and Gen Y.

### ACKNOWLEDGEMENT

This research received no specific grant from any funding agency in the public, commercial, or not-for-profit sectors.

### REFERENCES

Aaker, D. A. (1991). Managing brand equity: Capitalizing on the value of a brand name. *Journal of Business Research*, 29(3), 247–248. [https://doi.org/10.1016/0148-2963\(94\)90009-4](https://doi.org/10.1016/0148-2963(94)90009-4)

- Adams, W. M., & Jeanrenaud, S. (2008a). *Transition to sustainability: Towards a humane and diverse world*. IUCN.
- Adams, W. M., & Jeanrenaud, S. (2008b). *Transition to Sustainability: Towards a Humane and Diverse World IUCN Future of Sustainability Initiative 2008*. IUCN.
- Alalwan, A. A. (2018). Investigating the impact of social media advertising features on customer purchase intention. *International Journal of Information Management*, 42, 65–77. <https://doi.org/10.1016/j.ijinfomgt.2018.06.001>
- Alford, B. L., & Biswas, A. (2002). The effects of discount level, price consciousness and sale proneness on consumers' price perception and behavioral intention. *Journal of Business Research*, 55(9), 775–783. [https://doi.org/10.1016/S0148-2963\(00\)00214-9](https://doi.org/10.1016/S0148-2963(00)00214-9)
- Alhabash, S., Mundel, J., & Hussain, S. A. (2017). Social media advertising: Unraveling the mystery box. In *Digital Advertising* (pp. 285–299). Taylor and Francis. <https://doi.org/10.4324/9781315623252>
- Arora, T., & Agarwal, B. (2020). An Empirical Study on Determining the Effectiveness of Social Media Advertising: A Case on Indian Millennials. *International Journal of E-Business Research (IJEER)*, 16(2), 47–68. <https://doi.org/10.4018/IJEER.2020040104>
- Bland, J. M., & Altman, D. G. (1997). Statistics notes: Cronbach's alpha. *BMJ*, 314(7080), 572. <https://doi.org/10.1136/bmj.314.7080.572>
- Bland, J. M., & Altman, D. G. (1997). Statistics notes: Cronbach's alpha. *BMJ*, 314(7080), 572. <https://doi.org/10.1136/bmj.314.7080.572>
- Boateng, H., & Okoe, A. F. (2015). Consumers' attitude towards social media advertising and their behavioural response: The moderating role of corporate reputation. *Journal of Research in Interactive Marketing*, 9(4), 299–312. <https://doi.org/10.1108/JRIM-01-2015-0012>
- Brower, M., & Leon, W. (1999). *The Consumer's Guide to Effective Environmental Choices: Practical Advice from The Union of Concerned Scientists* (1st edition). Harmony.
- Bruhn, M., Schoenmueller, V., & Schäfer, D. B. (2012). Are social media replacing traditional media in terms of brand equity creation? *Management Research Review*, 35(9), 770–790. <https://doi.org/10.1108/01409171211255948>
- Chaudhuri, A., & Holbrook, M. B. (2001). The Chain of Effects from Brand Trust and Brand Affect to Brand Performance: The Role of Brand Loyalty. *Journal of Marketing*, 65(2), 81–93. <https://doi.org/10.1509/jmkg.65.2.81.18255>
- Chetioui, Y., Butt, I., & Lebdaoui, H. (2021). Facebook advertising, eWOM and consumer purchase intention-Evidence from a collectivistic emerging market. *Journal of Global Marketing*, 34(3), 220–237. <https://doi.org/10.1080/08911762.2021.1891359>
- Cobanoglu, C., & Cobanoglu, N. (2003). The Effect of Incentives in Web Surveys: Application and Ethical Considerations. *International Journal of Market Research*, 45(4), 1–13. <https://doi.org/10.1177/147078530304500406>
- Cobanoglu, C., & Cobanoglu, N. (2003). The Effect of Incentives in Web Surveys: Application and Ethical Considerations. *International Journal of Market Research*, 45(4), 1–13. <https://doi.org/10.1177/147078530304500406>
- Cossío-Silva, F.-J., Revilla-Camacho, M.-Á., Vega-Vázquez, M., & Palacios-Florencio, B. (2016). Value co-creation and customer loyalty. *Journal of Business Research*, 69(5), 1621–1625. <https://doi.org/10.1016/j.jbusres.2015.10.028>
- Dao, W.V., Nhat, A., Le, H., Ming-Sung, J. and Chen, D.C. (2014), “The review of marketing communications social media advertising value”, *International Journal of Advertising*, Vol. 33 No. 15, pp. 37-41.
- Diamantopoulos, A., Sarstedt, M., Fuchs, C., Wilczynski, P., & Kaiser, S. (2012). Guidelines for choosing between multi-item and single-item scales for construct measurement: A predictive validity perspective. *Journal of the Academy of Marketing Science*, 40(3), 434–449. <https://doi.org/10.1007/s11747-011-0300-3>
- Dijkstra, T., & Henseler, J. (2015). Consistent Partial Least Squares Path Modeling. *MIS Quarterly*, 39. <https://doi.org/10.25300/MISQ/2015/39.2.02>
- Drolet, A. L., & Morrison, D. G. (2001). Do We Really Need Multiple-Item Measures in Service Research? *Journal of Service Research*, 3(3), 196–204. <https://doi.org/10.1177/109467050133001>
- Fonseca-Santos, B., Corrêa, M. A., & Chorilli, M. (2015). Sustainability, natural and organic cosmetics: Consumer, products, efficacy, toxicological and regulatory considerations. *Brazilian Journal of Pharmaceutical Sciences*, 51(1), 17–26. <https://doi.org/10.1590/S1984-82502015000100002>
- Fornell, C. and Cha, J. (1994) Partial Least Squares. *Advanced Methods of Marketing Research*, 407, 52-78.
- Hair, J. F., Risher, J. J., Sarstedt, M., & Ringle, C. M. (2019). When to use and how to report the results of PLS-SEM. *European Business Review*, 31(1), 2–24. <https://doi.org/10.1108/EBR-11-2018-0203>
- Hasan, M., & Sohail, M. S. (2021). The Influence of Social Media Marketing on Consumers' Purchase Decision: Investigating the Effects of Local and Nonlocal Brands. *Journal of International Consumer Marketing*, 33(3), 350–367. <https://doi.org/10.1080/08961530.2020.1795043>
- Hawkins, K., & Vel, P. (2013). Attitudinal loyalty, behavioural loyalty and social media: An introspection. *University of Wollongong in Dubai - Papers*, 125–141. <https://doi.org/10.1362/146934713X13699019904605>
- Henseler, J., Ringle, C. M., & Sarstedt, M. (2015). A new criterion for assessing discriminant validity in variance-based structural equation modeling. *Journal of the Academy of Marketing Science*, 43(1), 115–135. <https://doi.org/10.1007/s11747-014-0403-8>
- Henseler, J., Ringle, C., & Sinkovics, R. (2009). The Use of Partial Least Squares Path Modeling in International Marketing. In *Advances in International Marketing* (Vol. 20, pp. 277–319). [https://doi.org/10.1108/S1474-7979\(2009\)0000020014](https://doi.org/10.1108/S1474-7979(2009)0000020014)
- Homer, P. (2008). Perceived quality and image: When all is not “rosy.” *Journal of Business Research*, 61, 715–723. <https://doi.org/10.1016/j.jbusres.2007.05.009>

- Hulland, J. (1999). Use of partial least squares (PLS) in strategic management research: A review of four recent studies. *Strategic Management Journal*, 20(2), 195–204.
- Jacoby, J. (1971). A model of multi-brand loyalty. *Journal of Advertising Research*, 11(3).
- Jacoby, J., & Kyner, D. B. (1973). Brand Loyalty Vs. Repeat Purchasing Behavior. *Journal of Marketing Research*, 10(1), 1–9. <https://doi.org/10.1177/002224377301000101>
- Jiménez-Castillo, D., & Sánchez-Fernández, R. (2019). The role of digital influencers in brand recommendation: Examining their impact on engagement, expected value and purchase intention. *International Journal of Information Management*, 49, 366–376. <https://doi.org/10.1016/j.ijinfomgt.2019.07.009>
- Keller, K. L. (1993). Conceptualizing, Measuring, and Managing Customer-Based Brand Equity. *Journal of Marketing*, 57(1), 1–22. <https://doi.org/10.1177/002224299305700101>
- Keller, K. L. (2016). Reflections on customer-based brand equity: Perspectives, progress, and priorities. *AMS Review*, 6(1), 1–16.
- Kelly, L., Kerr, G., & Drennan, J. (2010). Avoidance of Advertising in Social Networking Sites. *Journal of Interactive Advertising*, 10, 16–27. <https://doi.org/10.1080/15252019.2010.10722167>
- Khan, F., Gupta, N., & Swarup, C. (2022). Learners' perception, adoption intention, and adoption of e-learning technology: Measuring the mediating role of perceived trust. *Transylvanian Review*, 30(1), Article 1. <http://www.transylvanianreviewjournal.com/index.php/TR/article/view/864>
- Lai, Y., & Ren, J. (2016). The effect of social media advertising on consumer-based brand equity and behavioral intention: A case of we chat news feed advertisements in China. *2016 International Conference on Management Science and Engineering (ICMSE)*, 1716–1722. <https://doi.org/10.1109/ICMSE.2016.8365641>
- Langaro, D., Rita, P., & de Fátima Salgueiro, M. (2018). Do social networking sites contribute for building brands? Evaluating the impact of users' participation on brand awareness and brand attitude. *Journal of Marketing Communications*, 24(2), 146–168. <https://doi.org/10.1080/13527266.2015.1036100>
- Li, M.-W., Teng, H.-Y., & Chen, C.-Y. (2020). Unlocking the customer engagement-brand loyalty relationship in tourism social media: The roles of brand attachment and customer trust. *Journal of Hospitality and Tourism Management*, 44, 184–192. <https://doi.org/10.1016/j.jhtm.2020.06.015>
- Liu, C.-L. (2014). The impact of social cues and effectiveness in check-in advertising. *Kybernetes*, 43, 984–1002. <https://doi.org/10.1108/K-01-2014-0015>
- Mukherjee, K., & Banerjee, N. (2017). Effect of Social Networking Advertisements on Shaping Consumers' Attitude. *Global Business Review*, 18(5), 1291–1306. <https://doi.org/10.1177/0972150917710153>
- Nasir, V. A., Keserel, A. C., Surgit, O. E., & Nalbant, M. (2021). Segmenting consumers based on social media advertising perceptions: How does purchase intention differ across segments? *Telematics and Informatics*, 64, 101687. <https://doi.org/10.1016/j.tele.2021.101687>
- Oliver, R. L. (1999). Whence Consumer Loyalty? *Journal of Marketing*, 63(4\_suppl1), 33–44. <https://doi.org/10.1177/00222429990634s105>
- Ospina, E.-O. (2019). *The rise of social media*. Our World in Data. <https://ourworldindata.org/rise-of-social-media>
- Park, C. S., & Srinivasan, V. (1994). A Survey-Based Method for Measuring and Understanding Brand Equity and Its Extendibility. *Journal of Marketing Research*, 31(2), 271–288. <https://doi.org/10.2307/3152199>
- PwC-IAB Report. (2021). *Internet Advertising Revenue Report: Full Year 2021*. IAB. <https://www.iab.com/insights/internet-advertising-revenue-report-full-year-2021/>
- Raji, R. A., Rashid, S., & Ishak, S. (2019). The mediating effect of brand image on the relationships between social media advertising content, sales promotion content and behavioural intention. *Journal of Research in Interactive Marketing*, 13(3), 302–330. <https://doi.org/10.1108/JRIM-01-2018-0004>
- Rathore, A. K., Ilavarasan, P. V., & Dwivedi, Y. K. (2016). Social media content and product co-creation: An emerging paradigm. *Journal of Enterprise Information Management*, 29(1), 7.
- Rauschnabel, P. A., Felix, R., & Hinsch, C. (2019). Augmented reality marketing: How mobile AR-apps can improve brands through inspiration. *Journal of Retailing and Consumer Services*, 49, 43–53. <https://doi.org/10.1016/j.jretconser.2019.03.004>
- Salisbury, W. D., Pearson, R. A., Pearson, A. W., & Miller, D. W. (2001). Perceived security and World Wide Web purchase intention. *Industrial Management & Data Systems*, 101(4), 165–177. <https://doi.org/10.1108/02635570110390071>
- Sari, D. K., Suziana, S., & Games, D. (2020). An evaluation of social media advertising for Muslim millennial parents. *Journal of Islamic Marketing*, 12(9), 1835–1853. <https://doi.org/10.1108/JIMA-02-2020-0055>
- Sarr, F., & Ba, M. (2017). The Capability Approach and Evaluation of the Well-Being in Senegal: An Operationalization with the Structural Equations Models. *Modern Economy*, 8(1), Article 1. <https://doi.org/10.4236/me.2017.81007>
- Schnackenberg, A., & Tomlinson, E. (2014). Organizational Transparency: A New Perspective on Managing Trust in Organization-Stakeholder Relationships. *Journal of Management*, 42. <https://doi.org/10.1177/0149206314525202>
- Seo, E.-J., & Park, J.-W. (2018). A study on the effects of social media marketing activities on brand equity and customer response in the airline industry. *Journal of Air Transport Management*, 66, 36–41. <https://doi.org/10.1016/j.jairtraman.2017.09.014>
- Shmueli, G., & Koppius, O. R. (2011). Predictive Analytics in Information Systems Research. *MIS Quarterly*, 35(3), 553–572. <https://doi.org/10.2307/23042796>
- Soil association. (n.d.). *What Does Organic Beauty Mean? | Soil Association*. Retrieved December 30, 2022, from <https://www.soilassociation.org/take-action/organic-living/beauty-wellbeing/what-does-organic-beauty-mean/>



- Statista. (2022). *Social Media Advertising—Global | Market Forecast*. Statista. <https://www.statista.com/outlook/dmo/digital-advertising/social-media-advertising/worldwide>
- Statista. (2022, November 22). *Social media advertising and marketing worldwide*. Statista. <https://www.statista.com/topics/1538/social-media-marketing/>
- Sundar, S. S., & Marathe, S. S. (2010). Personalization versus Customization: The Importance of Agency, Privacy, and Power Usage. *Human Communication Research*, 36(3), 298–322. <https://doi.org/10.1111/j.1468-2958.2010.01377.x>
- Truong, Y., & Mccoll, R. (2011). Intrinsic motivations, self-esteem, and luxury goods consumption. *Journal of Retailing and Consumer Services*, 18, 555–561. <https://doi.org/10.1016/j.jretconser.2011.08.004>
- Usher, K., Woods, C., Casellac, E., Glass, N., Wilson, R., Mayner, L., Jackson, D., Brown, J., Duffy, E., Mather, C., Cummings, E., & soi Irwin, P. (2014). Australian health professions student use of social media. *Collegian (Royal College of Nursing, Australia)*, 21(2), 95–101. <https://doi.org/10.1016/j.colegn.2014.02.004>
- Wang, X., Yu, C., & Wei, Y. (2012). Social Media Peer Communication and Impacts on Purchase Intentions: A Consumer Socialization Framework. *Journal of Interactive Marketing*, 26(4), 198–208.
- Wu, S.-I., & Jang, J.-Y. (2014). The impact of ISO certification on consumers' purchase intention. *Total Quality Management & Business Excellence*, 25(3–4), 412–426. <https://doi.org/10.1080/14783363.2013.776770>
- Xu, H., Oh, L. B., & Teo, H. H. (2009). Perceived effectiveness of text vs. Multimedia Location-Based Advertising messaging. *International Journal of Mobile Communications*, 7(2), 154. <https://doi.org/10.1504/IJMC.2009.022440>
- Yadav, M., & Rahman, Z. (2017). Measuring consumer perception of social media marketing activities in e-commerce industry: Scale development & validation. *Telematics and Informatics*, 34(7), 1294–1307. <https://doi.org/10.1016/j.tele.2017.06.001>
- Yoo, B., & Donthu, N. (2001). Developing and validating a multidimensional consumer-based brand equity scale. *Journal of Business Research*, 52(1), 1–14. [https://doi.org/10.1016/S0148-2963\(99\)00098-3](https://doi.org/10.1016/S0148-2963(99)00098-3)
- Zarrad, H., & Debabi, M. (2012). Online Purchasing Intention: Factors and Effects. *International Business and Management*, 4(1), Article 1. <https://doi.org/10.3968/j.ibm.1923842820120401.2115>
- Zembik, M. (2015). *Brand Image in Social Media – an Outline of the Research Related Issues*. 203–212.
- Zhang, J., & Mao, E. (2016). From Online Motivations to Ad Clicks and to Behavioral Intentions: An Empirical Study of Consumer Response to Social Media Advertising. *Psychology & Marketing*, 33(3), 155–164. <https://doi.org/10.1002/mar.20862>
- Zhang, Y. (2015). The Impact of Brand Image on Consumer Behavior: A Literature Review. *Open Journal of Business and Management*, 3(1), Article 1. <https://doi.org/10.4236/ojbm.2015.31006>

## **Home Care and Mobile Health Services Provision for Rural Dwellers: A Conceptual Framework of Poverty Alleviation and Rural Development**

Sunday Adewale Olaleye <sup>1,\*</sup>  
Ismaila Temitayo Sanusi <sup>2</sup>  
Jari Salo <sup>3</sup>  
Esther Olubunmi Olaleye <sup>4</sup>

\*Corresponding author

<sup>1</sup> School of Business, Jamk University of Applied Sciences, Jyväskylä, Finland, sunday.olaleye@jamk.fi

<sup>2</sup> School of Computing, University of Eastern Finland, ismaila.sanusi@uef.fi

<sup>3</sup> Department of Economics and management, University of Helsinki, Helsinki, Finland, jari.salo@helsinki.fi

<sup>4</sup> Health and Welfare, Novia University of Applied Sciences, Vaasa, Finland, esther.olaleye@edu.novia.fi

### **ABSTRACT**

Health-related issues remain a continuous point of discussion globally among policymakers, health experts and researchers because there is no one-time solution to health problems. This study intends to link home care and mobile health services to illuminate the poverty-stricken society on alleviating poverty through smart health services. First, we conducted a literature review on mobile health and rural nursing. Second, we embarked on a thoughtful analysis to include influential materials not found in the literature reviewed. Third, we analysed the external influences and grouped them accordingly. Fourth, we integrate the factors into a conceptual model showing external and internal factors. Fifth, we analysed the role of mobile technology in rural nursing and finally developed practice recommendations. This study explores the urgent need for home care health services for rural dwellers with three pertinent questions: (1) How can home care and mobile health services enhance social development? (2) How can government policies impact home care mobile health services for rural dwellers? (3) Why are home care and mobile health services necessary for rural dwellers? The study employs the concepts of home care and mobile health services with an insightful literature review and integrated theories to probe poverty permeation and health inequality. It is expected that introducing home care and mobile health services will lead to easiness and convenience for rural dwellers and give assurance as they have access to treatment in the confines of their homes and the language they understand with the aid of smart nurses and smart technologies.

*Keywords:* Home care, Mobile Health Services, Poverty Alleviation, Smart Health Services.

### **INTRODUCTION**

Health-related issues remain a continuous point of discussion globally among policymakers, health experts and researchers because there is no one-time solution to health problems (Rashid *et al.*, 2022; Ubong *et al.*, 2023). The healthcare service in-home care is among the most critical, complex, and vital health sectors in the modern world (Nyashanu *et al.*, 2022). Home care can be considered under three subdivisions: Home-physician health care services, Home-private duty nursing care services and Home-Personal care and companionship services. The three types of home care provide various services, which entail helping the seniors manage their daily lives, handling complex medical conditions or situations with chronic patients with injuries, chronic health issues, patients recuperating from a medical setback, caring for the aged or people with special needs or a disability. Doctors, nurses, and therapists provide the three types of home care to improve the health condition, quality, and longevity of several lives every minute of each day. Conceptually, there needs to be a link between home care, mobile health, and poverty alleviation. This study intends to link home care and mobile health services to illuminate the poverty-stricken society on alleviating poverty through smart health services. The use of digital technologies, particularly mobile and wireless technologies, to improve and enhance global health needs and objectives has been associated with terminologies such as mobile health or mHealth (WHO, 2011). The healthcare industry is among the topmost data-intensive and data-driven industries globally because data is generated continuously and churned out from private and public healthcare providers, laboratories, and pharmacies alike. Huge data affects information creation, storage, retrieval, and transmission, posing a major challenge in healthcare delivery. However, the possibility of integrating mHealth into extant healthcare services has been considered in the literature (Labrique *et al.*, 2013; Ruxwana, 2007; UN, 2012), as well as in low and middle-income countries (Mehl and Labrique, 2014; Ruxwana, 2007; UN, 2012) which has the potential of impacting the lives peoples living in such regions. The potential of employing digital technologies to improve and support the delivery of healthcare solutions (Akter and Ray, 2010; Odendaal *et al.*, 2015) has been established.

Poverty, on the other hand, is compared to a disease that needs an instant cure. Poverty is spreading like wildfire in Sub-Saharan Africa, especially in Nigeria, and it is a multidimensional complex issue nationally influencing rural dweller negatively. Unstable leadership roles, porous financial handling, greed, and insubordination can be traced to escalating poverty in a country where lawlessness is the norm (Sam, 2014). Nigeria, with a population of 225,107,750 million as of 29.09.2023 (Worldometer, 2023), constitutes 46.48% of the rural dwellers in 2022, according to World Bank collection of development indicators is combating unpalatable health-seeking behaviour that is increasing the mortality rate daily because of insufficient medical care. According to Reed and Mberu (2014), Nigeria's population exceeds other countries in Africa, and the vast demography of Nigeria strikes equilibrium with its challenges. In Nigeria, among the affluent population, a few of the home care treatment in certain quarters has become so critical that home care treatment has been plagued with missed diagnoses, lapses or breaches in patient health history, lack of security and confidentiality, improper applications of treatment, failure to respond and adapt to new conditions or health issues that arise during treatment.

According to Iyalomh and Iyalomhe (2012), this alarming situation has exceeded the stethoscope's reach. The WHO statistics (Sun et al., 2013) revealed 71.4 years of life expectancy, 5.9 million mortality rates and about 16,000 deaths daily. Meanwhile, 56% of communicable, maternal, and perinatal conditions characterize the causes of untimely death globally. The severity of road traffic injuries and lackadaisical attitude to health care are highly prevalent in the African region. The rural dwellers in these regions depend on traditional medication and alternative medicine to tackle maternal mortality, newborn and child mortality, communicable diseases, non-communicable diseases, mental health, substance abuse, road traffic injuries and death from environmental pollution. These health-related challenges are part of the 17 Sustainable Development Goals accepted by the world leaders in 2015. A broad connection between health and wealth calls for the quick attention of policymakers and health practitioners.

The theory triangulation of critical social, innovation diffusion and rural nursing theories is applied to examine how home care and mobile health services are a booster of poverty alleviation. The previous researcher focused on mobile health services in China based on a comparison of age (Deng et al., 2014), acceptance of mobile health services with interest in models comparison (Coyte and McKeever, 2016), an overview of Canadian home-care utilization and how the program overcome the initial resistance (Wodchis, Austin, and Henry, 2016), longitudinal study of high-cost users of health care (Wodchis, Austin and Henry, 2016), swallowing and nutritional status of Japanese older people (Okabe et al., 2016), home care scheduling problem (Braekers, Hartl, Parragh, and Tricoire, 2016) and home mechanical ventilation patients (Vitacca, et al., 2016). This study discovered the gap in country and methodology in-home care and mobile health services in Africa and Nigeria. The study integrates Critical Social Theory and Innovation Diffusion Dimension to extend rural nursing theory and contribute to medical literature. It offers a new meaning to home care and mobile health services as an antecedent of poverty alleviation and rural development.

This study is divided into five parts. The first section introduces home care and health services as an antecedent of rural development. The second section critically reviews existing literature on poverty alleviation, home care and mobile health services and relevant theories. The study's third section focuses on the conceptual framework of home care and mobile health services. The fourth section showcases the future of home care and mobile health services. The fifth section presents the contribution, policy implications and conclusion. The last part also reveals the study limitations and future research path.

### **Types of Home Care Services**

To fully understand how mobile health services can be developed to improve home care services, the knowledge gap in the types of home care services must be bridged. As briefly described earlier in the introduction, the three home care services are home-physician health care, home-private duty nursing care, and home-personal care and companionship services. The home-personal care and companionship services entail helping the seniors to manage their daily lives in the areas of bathing, grooming, using the toilet, and dressing, meal planning and preparation, light housekeeping, laundry, running errands, medication reminders and picking up prescriptions, escort to appointments or meetings, helping with activities or hobbies, and general companionship. These services have become critical for people living with dementia or Alzheimer's disease.

Demographic projections reveal that people aged over 60 are living with chronic health conditions, injuries and disabilities, which will continue to increase (United Nations, 2006). The rapidly ageing population across the globe and the limited healthcare facilities are increasingly placing a high demand for home care and healthcare services. Earlier studies reveal the alarming increasing shortage of healthcare nurses and physicians, including home caregivers for seniors (Super, 2002) and registered nurses (Murray, 2002). In the past, robots have been recommended as a reasonable potential aid device that can assist in closing the widening gap between the number of healthcare professionals, services, and the ageing population's need and supply of healthcare services. The robot can be considered a mobile technology housed in a mobile body and can behave intelligently to recognise the environment around it (Ichbiah, 2005). Robots are delivering similar services executed by the three types of home care services: surgical robots for surgical operations (Howe, Matsuoka, 1999), rehabilitation robots that aid with rehabilitation therapy (Krebs et al., 2003), robots that assist the disabled and cognitively impaired maintain their independence (Tejima, 2001; Mataric et al., 2007), robots that motivate the aged and other age groups to exercise and lose



essay provides a structured literature review summarising key findings and insights from recent studies across diverse healthcare and nursing topics. Each study offers valuable contributions to the field and collectively contributes to understanding the multifaceted nature of healthcare and nursing practices.

In their study, Lee and Charlene explored the perceptions and needs of service providers in rural healthcare settings. Employing a naturalistic inquiry approach with field research techniques, they delved into rural healthcare professionals' unique challenges. Their qualitative analysis revealed four major themes: the definition of health, distance and access to resources, the symptom-action-timeline process, and choice. These themes shed light on the complex interplay of factors influencing healthcare delivery in rural areas (Lee and Charlene, 2004). Also, Lin's research investigated the impact of cross-cultural competence on nursing intellectual capital and utilised quantitative methods. The study found that outcome expectation significantly influences nurses' cross-cultural competence, emphasising the importance of addressing outcome expectations in cross-cultural training programs. Furthermore, the research highlighted the positive correlation between nurses' cross-cultural competence and nursing intellectual capital, underlining the role of cultural competence in improving patient care (Hsien-Cheng Lin, 2015).

On the other hand, Lauder et al. (2006) proposed an intriguing conceptual framework combining social capital theories and transaction costs to understand nursing practices in rural healthcare settings. Although a conceptual paper, their work paves the way for future research into how these theories can provide a framework for measuring nurses' contributions to rural health care. Likewise, Furuta et al. (2016) conducted a prospective observational cohort study investigating the relationship between swallowing function and nutritional status in Japanese older adults receiving home care services. Their findings challenged conventional wisdom, revealing that oral health status is not directly associated with malnutrition, a vital insight for the care of elderly populations.

Further, Bryan et al. (2016) conducted a comprehensive literature review on Mobile Integrated Health Care and Community Paramedicine. Their review synthesised observations from existing program data, suggesting that these innovative systems may prevent congestive heart failure readmissions, reduce EMS frequent-user transport, and decrease emergency department visits. This review highlights the evolving landscape of healthcare delivery systems, while Sun (2016) quantitative study investigated the factors influencing tool choice in innovation diffusion. The empirical results revealed that tool experiences substantially impact specific tool readiness at the within-subject level. In contrast, user characteristics have weaker effects at the between-subject level. This research provides valuable insights into the dynamics of tool adoption in healthcare innovation.

Robling and his team conducted a mixed-method study to assess the effectiveness of a nurse-led intensive home visitation program for first-time teenage mothers. The results indicated that adding the Family Nurse Partnership to existing healthcare and social care yielded only short-term benefits to primary outcomes. This pragmatic trial offers insights into the complexities of nurse-led interventions (Robling et al., 2016). In advancing the discussion of home care, Christian et al. (2017) literature review focused on the routing and scheduling challenges in home health care (HHC). The review provided a comprehensive overview of current work in the field, highlighting recent advances and future research directions. It emphasised the critical trade-off between costs and client convenience, a central concern in HHC optimisation. Additionally, Vitacca et al. (2007) conducted a quantitative survey to assess the real-life burden experienced by home mechanical ventilation patients, particularly those with neuromuscular disorders (NM). This survey revealed essential insights into patients' challenges and informed strategies for improving their quality of life.

Braekers and his co-authors presented computational experiments based on real-life data to analyse the trade-off between costs and client inconvenience in-home care scheduling. Their findings highlighted service providers' considerable challenge in balancing costs and client convenience. The study suggests potential improvements in service levels without significant additional costs (Braekers et al., 2016). In contrast, Zhaohua et al. (2014) investigated the adoption of mobile health services among middle-aged and older users in China. Their survey findings identified factors predicting the intention to use mobile health services, shedding light on the role of perceived value, attitude, perceived behaviour control, and technological anxiety. This research deepened the understanding of technology adoption in healthcare. Progressively, Anita et al. (2019) conducted a mixed-method study exploring the readiness of rural older adults to adopt mobile health technology. Their research uncovered key facilitators, including ease of use, convenience, affordability, and barriers related to privacy and security concerns. These findings are crucial for designing technology-driven healthcare solutions that cater to older populations.

This literature review highlights healthcare and nursing research's diverse and evolving landscape. These studies collectively contribute to understanding the challenges and opportunities within these fields, providing insights into the complexities of healthcare delivery, patient care, and the adoption of innovative technologies. As healthcare evolves, these insights serve as valuable foundations for further research and improvements in healthcare practices and policies.

## **METHODOLOGY**

The study adopts the six steps of methodology suggested by Marek (2014). First, we conducted a literature review on mobile health and rural nursing. Second, we embarked on a thoughtful analysis to include influential materials not found in the literature reviewed. Third, we analysed the external influences and grouped them accordingly. Fourth, we integrate the factors

into a conceptual model showing external and internal factors. Fifth, we analysed the role of mobile technology in rural nursing and finally developed practice recommendations. This study intends to explore the urgent need for home care health services for rural dwellers with three pertinent questions: (1) How can home care and mobile health services enhance social development? (2) How can government policies impact home care mobile health services for rural dwellers? (3) Why are home care and mobile health services necessary for rural dwellers? The study employs the concepts of home care and mobile health services with an insightful literature review and integrated theories to probe poverty permeation and health inequality.

### **Home Care and Mobile Health Services Conceptual Framework**

Tablets, smartphones, and e-readers are relatively easy to use, and age does not have to be a barrier. Individuals of various age brackets, including older adults, are already accustomed to using everyday technology, such as those incorporated into automobiles, various electrical appliances, and automated teller machines (ATMs) (Depatie and Bigbee, 2013). Research and advancement in the healthcare delivery system have brought the knowledge to manage people with multiple chronic illnesses. Goins and Krout (2006) assert that rural youth and adults are more likely than their urban counterparts to have chronic illnesses and face more barriers in accessing health care. According to Milligan (2009), limited healthcare resources and the reduced availability of formal and informal caregivers, services and support for people living in rural communities result in many pressing healthcare problems that must be addressed. Innovative programs incorporating remote and home-based care solutions, developed with a focus on the unique needs of the rural populace to promote wellness and prevent and manage chronic illness, are possible solutions. Three theories were discussed to explain the intervention of introducing the health care delivery system in rural communities. They are Critical Social Theory, Innovation Diffusion Theory (Rogers, 2003) and Rural Nursing Theory (Long and Weinert, 1989). Each of these theories will be described along with their application to the study.

### **Critical Social Theory**

According to Grams and Christ (1992), critical social theory (CST), as a form of science and inquiry, examines relationships of power and the underlying structures in society that produce population inequalities. Stevens (1989) gave examples of societal structures, such as the types of employment and wages made available to specific groups of people, distribution of wealth, access to education, and availability of healthcare services. CST assumes that societal, cultural, political, and economic circumstances are historically created, alterable, and not natural or fixed. This framework advocates for a type of consciousness that regards how these social structures operate to oppress some members of society while systematically privileging others. Therefore, it has an emancipatory intent and seeks to challenge conventional assumptions and social arrangements to move beyond the "what is" to the "what could be" (Thomas 1993). *Critical social theory* is an action-oriented theoretical approach that may be applied to nursing research and practice (Henderson, 1995). Critical social theory can be used to assess how socially derived power structures filter into healthcare practices in terms of how deficits in health are assessed and managed and how they affect communication between nurses and patients. Critical social theory can also examine how power relations in healthcare interactions affect communication between healthcare providers and patients (Mohammed, 2006).

### **Five Innovation Diffusion Dimension**

To ensure a comprehensive assessment of the appropriate parameters to determine the potential for the uptake of this innovative health care delivery. Everett Rogers' diffusion of innovations was selected as one of the theoretical frameworks for the phenomenon being discussed. In this study, the innovation examined consisted of home care and mobile health services. IDT has been used in research investigating the diffusion of innovation in healthcare delivery (Depatie and Bigbee, 2013). The rate of adoption of an innovation, according to Rogers (2003), is highly dependent upon the quality or attributes of that innovation. Rogers argues that there are five key characteristics of innovations that affect their rates of adoption: 1) relative advantage, 2) compatibility, 3) complexity, 4) trialability, and 5) observability (p. 15). Relative advantage is "the degree to which an innovation is perceived as better than the idea it supersedes." At the same time, compatibility describes "the degree to which an innovation is perceived as being consistent with the existing values, past experiences, and needs of potential adopters" (Rogers (2003), p. 15). Complexity refers to "the degree to which an innovation is perceived as difficult to understand and use," and trialability pertains to "the degree to which an innovation may be experimented with on a limited basis" (Rogers (2003, p. 16). The last quality of innovation, observability, is described by Rogers as "the degree to which the results of an innovation are visible to others" (Rogers (2003, p. 16). What is interesting about these five qualities is the connection between the successful diffusion of innovation and the community's values, norms, assumptions, and behaviours. Based on the five characteristics mentioned above, it is evident how much an innovation relies on its community, organisation, or system to be implemented successfully.

### **Rural Nursing Theory**

The theory by Long and Weinert (1989) claims that rural healthcare perspectives vary significantly from those in urban and suburban areas. According to Lee and Winters (2012), many healthcare needs of rural dwellers cannot be adequately addressed by applying nursing models developed in urban or suburban areas but require unique approaches emphasising the special needs of this population. The authors stressed that the rural nursing theory base was developed through studies generalisable to rural persons living in sparsely populated areas and has been generalised to all rural populations, especially from the clinical perspective (Lee and Winters, 2012). Rural dwellers define *health* as the ability to work, be productive, and do common tasks.

This belief often leads rural dwellers to prioritise work priorities for healthcare. Time and distance to receive health care, as well as cost, are of concern to rural individuals. Many will self-treat to save time and money or wait until their health is severely compromised before travelling for care (Depatie, Bigbee, 2013). Shannon (1998) asserts that the theory for rural nursing evolved because of a recognised need for a framework for practice that considers the perceptions and needs of persons from whom care is being provided.

The theory reveals some key concepts or variables such as work beliefs and health beliefs (Long and Weinert, 1989), old-timer and newcomer (Long and Weinert, 1989), lack of anonymity, isolation and distance (Long and Weinert, 1989; Pierce, 2001), lack of access (Pierce, 2001), use of an informal network (Pierce, 2001), familiarity (Magilvy and Congdon, 2000) and self-reliance (Roberto, and Reynolds, 2001). The combined theory of critical social theory, innovation diffusion theory and rural nursing theory formed the integrated theories for home care and mobile health service programs, as evident in Figure 2.

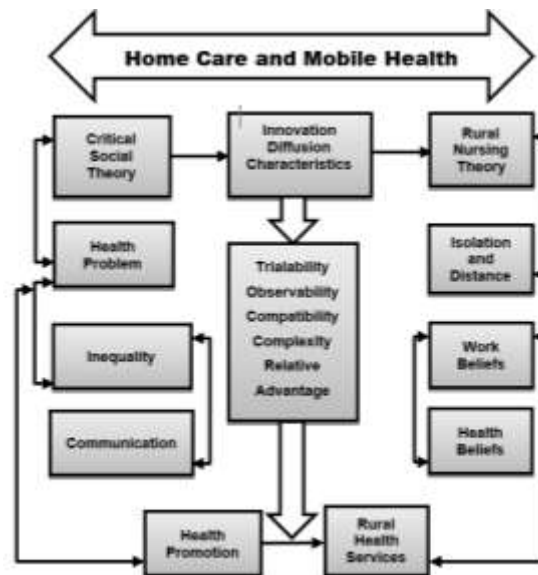

Figure 2: Integrated Theories for Home Care and Mobile Health Services.

### INTEGRATED THEORIES FOR HOME CARE AND MOBILE HEALTH SERVICES

Developing an integrated theory base for home care and rural nursing is necessary. Many healthcare needs of rural dwellers cannot be adequately met using existing models, which require unique approaches emphasising the special needs of this population. This study's home care and mobile health services program model comprises Critical Social Theory, Innovation Diffusion Characteristics and Rural Nursing Theory as represented in Figure 2. The variables under the Critical Social Theory are health problems, inequality, and communication. Innovation diffusion characteristics are trialability, observability, compatibility, complexity, and relative advantage, while Rural Nursing Theory has isolation and distance, work beliefs, and health beliefs as variables. The combination of these theories and constructs is to gain health promotion and provide rural health services, which are the aim of the innovative model to address home care and health needs of the rural people.

Different health problems are witnessed massively in rural areas, associated with several factors such as pollution, lack of access to clean drinking water, drug use, and inadequate emergency services. These health problems require adequate health care services, which are likely not available for self-medication or traditional home care with herbs and concoctions due to the remoteness of the communities. The attempt to seek adequate medical attention may be hindered by the distance to the healthcare facilities and inequalities among the residents of the rural communities — the difference in social status, wealth and opportunity indicated in healthcare access that left most of the disadvantaged at the mercy of self-medication. Since information is the lifeblood of healthcare, communication systems are the heart that pumps it (Touissant and Coiera, 2005). Another critical factor in health communication is communicating promotional health information such as in public health campaigns, health education and between health care practitioners and patients. The dissemination of health information is to influence personal health choices by improving health literacy. Health communication will help to increase demand or support for health services and increase the rural dwellers' knowledge and awareness of health issues.

Health belief helps explain why individual patients may accept or reject preventative health services or adopt healthy behaviours. The health belief model proposes that people will respond best to messages about health promotion or disease prevention when the following four conditions for change exist: (1) The person believes that he or she is at risk of developing a specific condition, (2) the person believes that the risk is severe and the consequence of developing the condition is undesirable, (3) the person believes that a particular behaviour change will reduce the risk, (4) The person believes that barriers to the behaviour change can be overcome and managed (EuroMed Info, 2018).



Distance means the separation (space, time, and behaviour) between the rural participants and their healthcare resources (Ballantyne, 1998; Henson et al., 1998). Dealing with a gap when accessing healthcare resources was a part of these participants' lives. Specific areas of concern mentioned were obtaining specialist care, prescription medications, and emergency care. The distance patients must travel to obtain treatment has long been recognised as a primary determinant of healthcare facilities. The distance factor is especially significant in rural settings where the density of western-type health facilities is often low, where most patients are likely to make the journey for treatment as pedestrians and where there are viable and usually more accessible alternate sources of medicine.

All these serves as a pointer to health promotion, that is, any planned combination of educational, political, environmental, regulatory, or organisational mechanisms that supports actions and conditions of living conducive to the health of individuals, groups, and the entire community. IDT has been used in research investigating the diffusion of innovation in healthcare delivery (DePATIE and Bigbee, 2013). The adoption rate of innovation, according to Rogers (2003), is highly dependent upon the quality or attributes of that innovation. As explained above, the five key characteristics of innovations are relative advantage, compatibility, complexity, trialability, and observability. These characteristics contribute to health promotion, having seen the effect of the innovation. Innovation Diffusion characteristics will help promote health and improve rural health services.

### **Acceptance of Mobile Health Care: Important Dependent Factors**

Healthcare technologies such as mobile health and robots for home care have been seen as inferior to human caring and contact (Sparrow and Sparrow, 2006). Mobile healthcare being consciously integrated into the life of the aged willingly is termed "acceptance". For acceptance of mobile health services to occur in any environment, three basic requirements: motivation for the usage of mobile health services, adequate ease of use and comfort of the mobile health services, and cognitive and emotional state of the users considered and met. Associated models for technology acceptance have found that perceived usefulness, ease of use, titillation and amusement directly correlate with people's adoption intentions (Kulviwat et al., 2007). The demographics of the target population in the urban and rural areas should be considered when deciding how mobile health services should be developed for a specific usage. Mainly, variables such as age, needs, and experience with technology, role, and culture are essential to accepting healthcare services.

### **Effect of Age on Usage**

In the usage of technology by older people, earlier research has found that when faced with problems, the older old (75 years and above) have a high probability of giving up and welcoming drawbacks and inconveniences in the comfort of their home rather than obtaining assistive solutions, in comparison with the young-old (65–74 years) (Giulini et al., 2005). Research suggests older people are less comfortable with computers and new technology than younger people (Czaja and Sharit, 1998). Additionally, older people are usually sceptical and frightened of contemporary technology than the young and less trusting in the abilities of specific ones (Scopelliti, Giuliani, and Fornara, 2005). To reduce this anxiety, older people prefer robots to be unthreatening, with a female voice, small size, slow-moving and less autonomous, and with a severe aspect and single colour. Older people have been found to interact more with a small, non-threatening cat robot than young people (Libin and Libin, 2004).

### **The Needs Factor of the Users**

There are several needs of the old and the older old, but the home care needs of the older person significantly influence their feelings toward mobile healthcare. As indicated in the previous sections, some older people require mobility, hearing or vision assistance. Some older people need reminders to take their medication continually and do other routine health activities without fail, whereas some also need much more social support. It has been found that older people tend to embrace assistive devices in healthcare and housing to enable them to obtain and or maintain their autonomy (Pain et al., 2007), particularly with the presence of a perceived need for the assistive device or technology (Tinker and Lansley, 2005). Making due diligence in discovering and assessing the needs of older people and matching these to the provided technology can result in higher acceptance rates (Kobb et al., 2003) because failure in some telemedicine projects has been partly attributed to poor assessment of the needs of the users of the technology (Brebner et al., 2005). Expectations of the future needs of older people can also play a critical role in acceptance. For example, one significant need of older people is higher anxiety regarding the loss of cognitive abilities as people advance in age, which was correlated with higher evaluations of a home care robot that could assist in providing reminders and finding things around the home of older (Cesta et al., 2007).

### **Experience with Technology/Mobile Health Care**

Most people in low- and middle-income countries often need to become more familiar with evolving technology (Dijkers et al., 1991). The lack of familiarity of older people from low/middle-income countries, particularly those living in rural communities with technology, is a major rationalism for people feeling precarious about specific technologies (Dijkers et al. 1991). Conversely, some older people living in Western cultures have first-hand experience with the usability of aiding devices, which can alter older people's attitudes from considering supporting devices inessential, considering them very beneficial (Forlizzi, 2005). Indeed, the acceptance of devices must be measured over time as people become familiar with robots. A classic example (Koay et al., 2007) found that peoples' preferences regarding technology changed over time during a five-week

trial as respondents became accustomed to the technology. Their findings reveal that, with time, the participants preferred the technology better than earlier (Wada and Shibata, 2007).

### **Cognitive Ability and Education of Users**

There is only a small amount of research on the effects of the level of education on attitudes towards robots—one of the scarce studies on cognitive ability and educational level sampled 123 older people in Italy. The result of the study indicated that a higher educational level has a direct correlation with greater acceptance of technological solutions for everyday botheration (Giulini et al., 2005). In most advanced countries, the cognitive ability and educational level of older people are more encouraging than those in low/middle-income countries, with the situation being worse for those living in rural areas. Poverty and lack of sound and adequate government policies is the major drawback to these regions' low education level.

### **Culture of Users**

The cultural differences of different people bring about different attitudes towards the acceptance of technology. Besides, the disparity in how societies conventionally care for older people will probably result in cultural differences in technology acceptance. This scenario culminates as cultural differences in people's relationship with the aged and their attitudes towards ageing and independent living. An example is people's attitudes towards their responsibilities, as revealed in some nurses' distrust of some technology, and therefore had unrealistic expectations and felt that their job security was imperilled (Novek et al., 2000).

### **Future of Home Care and Mobile Health Services**

The past and present situations in the medical field should be able to define its future direction. How can the past and the current challenges be controlled, with the associated risk and health inequality mitigated? Undoubtedly, technology has played a more significant role in the medical field in the past and even now. Robot-human interaction impacts medical surgery and a mobile device such as a tablet. Olaleye, Salo, and Ukpabi (2018) positioned tablets as a multi-tasking helpful device across different sectors. Tourangeau et al. (2017) emphasised health services without borders as health care that is functional as an auxiliary of conventional hospitals and clinics. Also, Olaleye, Sanusi, Agjei and Adusei-Mensah (2021) introduced an intervention of a mobile contact called "My Contact Person" (MCP) as an inevitable tool for paramedic health workers in emergencies. The ageing population of Western countries is a challenge to human resource management. This development calls for home-care nurses (Krings and Weinberger, 2018). Situations are tense in the developing countries of Africa, especially in Nigeria, where there is an uncontrollable population. To solve the problem of inequality and long queue in hospitals, (De Groot, Maurits and Francke 2018; Joseph et al., 2018) recommends assistive robotics in health care and a humanoid robot. This study envisages that there will be a renowned diffusion of personal health care services, robot health care services, chatbot health care services, predictive health care services, smart Nurses, Doctors, and smart Patients. The future health care services are moving towards self-service, aided service with artificial intelligence intervention for smart patients, a community of learning and sharing health service experiences. The government policy must support these projections to make it a reality.

## **IMPLICATION AND CONCLUSION**

This study is one of the pioneer studies in Sub-Saharan Africa and the integration of Critical Social Theory and Innovation Diffusion Dimension to extend the theory of rural nursing and contribute to medical literature as it offers a new meaning to home care and mobile health services as an antecedent of poverty alleviation and rural development. It is expected that introducing home care and mobile health services will lead to easiness and convenience for rural dwellers and give assurance as they have access to treatment in the confines of their homes and the language they understand with the aid of smart nurses and smart technologies. Home care and mobile health services will help decongest the seemingly crowded centres. It will alleviate poverty in rural communities by reducing the sickness burden hampering work productivity. On the other hand, it will create employment opportunities so that the government will recruit staff for the public health enlightenment program. Independent nurses or health care practitioners can also collaborate with Non-Governmental Organizations to champion the course. Medically excluded people due to their habitation remoteness will be reached and pave the way for mobile medical service accessibility, and this development will drastically reduce the mortality rate. This study concludes by calling for private and public funders to collaborate on advancing models of care for innovative solutions that will enable nurses to improve health and health care. The study recommends that healthcare organisations should support nurses in taking the lead in developing and adopting innovative patient-centred care models. Nurses and other healthcare providers must champion the mHealth program with their colleagues and patients. The government is challenged to identify, develop, implement, and evaluate innovative solutions to manage chronic disease and other illnesses. The study has practical relevance to medical practitioners, African governments, non-governmental agencies, and society.

In many rural African countries, mobile phones have been the first extant contemporary technology infrastructure that has dramatically reduced communication costs and prevented delays in response to emergencies and other disasters. Policies geared towards home care and mobile healthcare can significantly reduce the cost of communicating health-related issues, particularly between health professionals and rural dwellers. Several studies argued that mobile Phones have tangible economic benefits and other consumer welfare in specifically low and middle-income countries (Jensen, 2007; Aker, 2008; Klonner and Nolen, 2008; Aker, 2010; Oyelere et al., 2017). Policymakers and other agencies have always promoted the poverty-alleviation potential of mobile phones (Corbett, 2008), which will yield a similar result when integrated into home care

and mobile healthcare. An article in *The Economist* (2008) similarly reported: "A device that was a yuppie toy not so long ago has now become a potent force for economic development in the world's poorest countries".

Additionally, this conceptual insight reveals the inequities in the use of health services. It estimates the magnitude of the relationships between poverty alleviation and rural development. The utilisation of home care and mobile health services are linked explicitly to achieving MDG 1 (eliminating extreme poverty).

### Study Limitations and Further Research

The medical field is a vast research domain, and this study has successfully focused on home care and mobile health services in Nigeria. Future research endeavours should extend beyond a single-country study and adopt a multi-group analysis of home care and mobile health services across African countries. An empirical study with a mixed methodology would significantly enhance the conceptual paper, providing valuable insights.

Future researchers should explore the following research questions to contribute to the literature on home care and mobile health services:

1. Why is artificial intelligence, including robotics, chatbots, machine learning, and deep learning, necessary for the future of home care and mobile health services?
2. How can the government initiate and influence the diffusion of smart healthcare, smart medical practitioners, and smart patient engagement?
3. What strategies can governments and medical stakeholders employ to establish an ecosystem of smart healthcare in rural areas, facilitating consultation and collaboration?
4. How can governments effectively address the barrier of medical inequality in rural areas by integrating emerging technologies?
5. What impact can blockchain technology have on the payment system for healthcare services?

These questions, among others, present exciting avenues for exploration by future researchers. Examining the relevance of well-being and electronic healthcare in smart healthcare (Olawumi et al., 2022; Olaleye et al., 2023) is crucial.

### REFERENCES

- Ballantyne, J. (1998). Health resources and the rural client. In H.J. Lee (Ed.), *Conceptual basis for rural nursing* (pp. 178-188). New York: Springer.
- Braekers, K., Hartl, R. F., Parragh, S. N., & Tricoire, F. (2016). A bi-objective home care scheduling problem: Analyzing the trade-off between costs and client inconvenience. *European Journal of Operational Research*, 248(2), 428-443.
- Brebner, J. A., Brebner, E. M., & Ruddick-Bracken, H. (2005). Experience-based guidelines for the implementation of telemedicine services. *Journal of Telemedicine and Telecare*, 11(1\_suppl), 3-5.
- Cesta, A., Cortellessa, G., Giuliani, M. V., Pecora, F., Scopelliti, M., & Tiberio, L. (2007). Psychological implications of domestic assistive technology for the elderly. *PsychNology Journal*, 5(3).
- Coyte, P. C., & McKeever, P. (2016). Home care in Canada: Passing the buck. *Canadian Journal of Nursing Research Archive*, 33(2).
- Czaja, S. J., & Sharit, J. (1998). Age differences in attitudes toward computers. *The Journals of Gerontology Series B: Psychological Sciences and Social Sciences*, 53(5), 329-340.
- De Groot, K., Maurits, E. E., & Francke, A. L. (2018). Attractiveness of working in home care: An online focus group study among nurses. *Health & Social Care in the Community*, 26(1), 94-101.
- Deng, Z., Mo, X., & Liu, S. (2014). Comparison of the middle-aged and older users' adoption of mobile health services in China. *International Journal of Medical Informatics*, 83(3), 210-224.
- Depatie, A., Bigbee, J.L. (2013). Rural older adult readiness to adopt mobile health technology: A descriptive study. *Online Journal of Rural Nursing and Health Care*, 15, 150-184. England: Ashgate.
- Dijkers MI, deBear PC, Erlandson RF, Kristy K, Geer DM, Nichols A. (1991). Patient and staff acceptance of robotic technology in occupational therapy: a pilot study. *Journal of Rehabilitation Research and Development*, 28, 33-44.
- EuroMed Info (n.d.). The Health Belief Models. Retrieved from <https://www.euromedinfo.eu/the-health-belief-model.html/> (accessed 13 July 2018).
- Forlizzi, J. (2005). Robotic products to assist the aging population. *Interactions*, 12(2), 16-18.
- Giulini MV, Scopelliti M, and Fornara F. (2005). Elderly people at home: Technological help in everyday activities. In: *Proceedings of the 2005 IEEE international workshop on robots and human interactive communication*, (pp. 365-370). Nashville, TN.
- Goins, R.T., & Krout, J.A. (2006). Service delivery to rural older adults: Research, policy, and practice. New York: Springer.
- Grams, K.M., & Christ, M.A. (1992). Faculty workload formulas in nursing education: A critical theory perspective. *Journal of Professional Nursing*, 8, 96-104.
- Henderson, D. (1995). Consciousness raising in participatory research: Method and methodology for emancipatory nursing inquiry. *Advances in Nursing Science*, 27, 58-69.
- Henson, D., Sadler, T., & Walton, S. (1998). Distance. In H. J. Lee (Ed.), *Conceptual Basis for Rural Nursing*, 51-60. New York: Springer.

- Hou C., Jia S. and Takase K. (2003). Real-time multimedia applications in a web-based robotic telecare system. *Journal of Intelligent and Robotic Systems*, 38, 135–153.
- Howe R.D. and Matsuoka, Y. (1999). Robotics for surgery. *Annual Review of Biomedical Engineering*, 1, 211–240.
- Ichbiah, D. (2005). Robots: from science fiction to technological revolution. Harry N Abrams, New York.
- Iyalomhe, G. B., & Iyalomhe, S. I. (2012). Health-Seeking Behavior of Rural Dwellers in Southern Nigeria: Implications for Healthcare Professionals. *International Journal of Tropical Disease & Health*, 2(2), 62–71. <https://doi.org/10.9734/IJTDH/2012/973>
- Joseph, A., Christian, B., Abiodun, A. A., & Oyawale, F. (2018). A review on humanoid robotics in healthcare. In *MATEC Web of Conferences*, 153:02004. EDP Sciences.
- Kidd C.D. and Breazeal C. (2006). Sociable robot systems for weight maintenance. In: *Proceedings of the 3rd IEEE consumer communications and networking conference*, (pp. 253–257). Las Vegas, Nevada.
- Koay KL, Syrdal DS, Walters ML, Dautenhahn K. (2007). Living with robots: investigating the habituation effect in participants' preferences during a longitudinal human-robot interaction study. In: *Proceedings of the 16th IEEE international symposium on robot and human interactive communication RO-MAN*, (pp. 564–569). Jeju Island, Korea.
- Kobb R, Hilsen P, Ryan P. (2003). Assessing technology needs for the elderly: finding the perfect match for home. *Home Healthcare Now*, 21(10), 666–673.
- Krebs H.I., Palazzolo J.J., Dipietro L., Ferraro M., Krol J., Ranekleiv K., Volpe B.T. and Hogan, N. (2003). Rehabilitation robotics: performance-based progressive robot-assisted therapy. *Auton Robots*, 15:7–20
- Krings, B. J., & Weinberger, N. (2018). Assistant without Master? Some Conceptual Implications of Assistive Robotics in Health Care. *Technologies*, 6(13).
- Kulviwat S., Bruner G.C., Kumar, A., Nasco, S.A. and Clark, T. (2007). Toward a unified theory of consumer acceptance technology. *Psychology & Marketing*, 24(12), 1059–1084.
- Lee, H. J., & Winters, C. A. (2012). Testing rural nursing theory: Perceptions and needs of service providers. *Online Journal of Rural Nursing and Health Care*, 4(1), 51-63.
- Libin A.V and Libin E.V. (2004). Person-robot interactions from the robopsychologists point of view: the robotic psychology and robototherapy approach. *Proceedings of the IEEE*, 92(11), (pp. 1789–1803).
- Long, K.A., & Weinert, C. (1989). Rural nursing: developing the theory base. *Scholarly Inquiry for Nursing Practice*, 3(2), 113-127.
- Magilvy, J.K., & Congdon, J.G. (2000). The crisis nature of health care transitions for rural older adults. *Public Health Nursing*, 17(5), 336-345.
- Marek, M. (2014). Research Study Manuscript Outline. *Conference: Spring*.
- Matarić, M. J., Eriksson, J., Feil-Seifer, D. J., & Winstein, C. J. (2007). Socially assistive robotics for post-stroke rehabilitation. *Journal of Neuroengineering and Rehabilitation*, 4, 1-9.
- Milligan, C. (2009). There's no place like home: Place and care in an ageing society. Surrey.
- Mohammed, S. A. (2006). Scientific inquiry. *Journal for Specialists in Pediatric Nursing*, 11(1), 68-71.
- Murray, M.K. (2002). The nursing shortage: past, present, and future. *Journal of Nursing Administration*, 32, 79–84.
- Novak J, Bettes S, Burke K, and Johnston P. (2000). Nurses' perceptions of the reliability of an automated medication dispensing system. *Journal of Nursing Care Quality*, 14, 1–13.
- Nyashanu, M., Pfende, F., & Ekpenyong, M. S. (2022). Triggers of mental health problems among frontline healthcare workers during the COVID-19 pandemic in private care homes and domiciliary care agencies: Lived experiences of care workers in the Midlands region, UK. *Health & Social Care in the Community*, 30(2), 370-376.
- Okabe, Y., Furuta, M., Akifusa, S., Takeuchi, K., Adachi, M., Kinoshita, T., & Yamashita, Y. (2016). Swallowing function and nutritional status in Japanese elderly people receiving home-care services: a 1-year longitudinal study. *The Journal of Nutrition, Health & Aging*, 20, 697-704.
- Olaleye, S. A., Olaleye, E. O., Balogun, M. A., & Balogun, O. S. (2023). Global Spotlight of Students and Teachers Well-Being: A Bibliometric Viewpoint. In *EDULEARN23 Proceedings* (pp. 3658-3666). IATED.
- Olaleye, S.A., Salo, J. & Ukpabi, D.C. (2018). The Role of Reputation on Trust and Loyalty: A Cross-Cultural Analysis of Tablet E-Tailing. *International Journal of E-Business Research (IJEER)*, 14(2).
- Olaleye, S. A., Sanusi, I. T., Agjei, R. O., & Adusei-Mensah, F. (2021). Please call my contact person: mobile devices for a rescue mission during an emergency. *Information Discovery and Delivery*, 49(2), 114-122.
- Olawumi, O., Olaleye, S., Adusei-Mensah, F., Olawuni, A., & Agjei, R. O. (2022). Adoption and implementation of electronic healthcare management system-a bibliometric approach. *International Journal of Electronic Healthcare*, 12(1), 54-96.
- Oyelere, S. S., Joro, D. K., Olaleye, S. A., & Sunday, E. O. (2017). Mobile application for pre-screening of Ebola virus disease. In *AFRICON, 2017 IEEE* (pp. 512-517).
- Pain H, Gale CR, Watson C, Cox V, Cooper C. and Sayer A. (2007). Readiness of elders to use assistive devices to maintain their independence in the home. *Age Ageing*, 36, 465–467.
- Pierce, C. (2001). The impact of culture of rural women's descriptions of health. *Journal of Multicultural Nursing and Health*, 7, 50-53. New York: Springer
- Rashid, N. S. A., Chen, X. W., Mohamad Marzuki, M. F., Takshe, A. A., Okasha, A., Maarof, F., & Yunus, R. M. (2022). Development and Usability Assessment of a Mobile App (Demensia KITA) to Support Dementia Caregivers in Malaysia: A Study Protocol. *International Journal of Environmental Research and Public Health*, 19(19), 11880.
- Reed, H. E., & Mberu, B. U. (2014). Capitalizing on Nigeria's demographic dividend: reaping the benefits and diminishing the burdens. *Etude de la population africaine, African population studies*, 27, 319.

- Roberto, K.A., & Reynolds, S.G. (2001). The meaning of osteoporosis in the lives of rural women. *Health Care for Women International*, 22:599-611.
- Rogers, E.M. (2003). *The diffusion of Innovation*, 5th edition.
- Sam, I. O. (2014). Achieving sustainable poverty reduction and rural development in Nigeria through local economic development strategies. *American Journal of Rural Development*, 2, 13-19.
- Scopelliti, M., Giuliani, M. V., & Fornara, F. (2005). Robots in a domestic setting: a psychological approach. *Universal Access in the Information Society*, 4, 146-155.
- Shannon, A.M. (1998). Developing an educational structure for rural nursing research and theory. In H.J. Lee (Ed.), *Conceptual basis for rural nursing* (pp. 399-407). New York: Springer.
- Sparrow, R., & Sparrow, L. (2006). In the hands of machines? The future of aged care. *Minds and Machines*, 16, 141-161.
- Stevens, P.E. (1989). A critical social reconceptualization of environment in nursing: Implications for methodology. *Advances in Nursing Science*, 11(4), 56-68.
- Sun, Y., Wang, N., Guo, X., & Peng, Z. (2013). Understanding the acceptance of mobile health services: a comparison and integration of alternative models. *Journal of Electronic Commerce Research*, 14(2), 183.
- Super N. (2002). Who will be there to care? The growing gap between caregiver supply and demand. In: *National Health Policy Forum, George Washington University, Washington DC*.
- Tejima, N. (2001). Rehabilitation robotics: A review. *Advanced Robotics*, 14(7), 551-564.
- Thomas, J. (1993). *Doing critical ethnography* (Vol. 26). Newbury Park, CA: Sage.
- Tinker, A., & Lansley, P. (2005). Introducing assistive technology into the existing homes of older people: Feasibility, acceptability, costs, and outcomes. *Journal of Telemedicine and Telecare*, 11(1), 1-3.
- Touissant, P. J., & Coiera, E. (2015). Supporting communication in health care. *International Journal of Medical Information*, 74, 779-781.
- Tourangeau, A. E., Patterson, E., Saari, M., Thomson, H., & Cranley, L. (2017). Work-related factors influencing home care nurse intent to remain employed. *Health Care Management Review*, 42(1), 87-97.
- Ubong, D., Stewart, L., Sepai, O., Knudsen, L. E., Berman, T., Reynders, H., & Alvito, P. (2023). Application of human biomonitoring data to support policy development, raise awareness, and environmental public health protection among countries within the HBM4EU project. *International Journal of Hygiene and Environmental Health*, 251, 114170.
- United Nations. (2006). *World Population Prospects: The 2006 Revision*. United Nations, New York.
- Vitacca, M., Escarrabill, J., Galavotti, G., Vianello, A., Prats, E., Scala, R., & Balbi, B. (2016). Home mechanical ventilation patients: A retrospective survey to identify the level of burden in real life. *Monaldi Archives for Chest Disease*, 67(3).
- Wada, K., & T. (2007). Robot Therapy in a Care house—Change of relationship among the residents and seal robot during a 2-month-long study. In *Proceedings of the 16th IEEE International Symposium on Robot and Human Interactive Communication RO-MAN* (pp. 107-112). Jeju Island, Korea.
- World Health Organization. (2018). *Global Health Observatory (GHO) data*. Retrieved from [http://www.who.int/gho/mortality\\_burden\\_disease/en/](http://www.who.int/gho/mortality_burden_disease/en/) (accessed March 4, 2018).
- Wodchis, W. P., Austin, P. C., & Henry, D. A. (2016). A 3-year study of high-cost users of health care. *Canadian Medical Association Journal*, 180(3), 182-188.
- Worldometer. (2023). *Nigeria Population*. Retrieved from <https://www.worldometers.info/world-population/nigeria-population/#:~:text=The%20current%20population%20of%20Nigeria,latest%20United%20Nations%20data%201> (accessed September 29, 2023).



## Impact of Artificial Intelligence (AI) in Enhancing Productivity and Reducing Stress Among Students

Eldon Y. Li <sup>1</sup>

Anila Jan <sup>2,\*</sup>

\*Corresponding author

<sup>1</sup> Chair Professor, National Chung Cheng University, Chiayi, Taiwan, miseli@ccu.edu.tw

<sup>2</sup> Doctoral Student, National Chung Cheng University, Chiayi, Taiwan, anilajan@alum.ccu.edu.tw

### ABSTRACT

The rapid growth of chatbots and artificial intelligence (AI) has brought about a new time of learning and exploration. This research article investigates the profound implications of AI in education, focusing specifically on its impact on student productivity and stress reduction. Through a systematic literature review, 15 articles were analyzed, covering the period from 2017 to 2023. The findings highlight the potential of AI-powered educational tools to revolutionize traditional education paradigms by personalizing the learning experience, automating administrative tasks, and providing intelligent support. AI enables effective addressing of the challenges faced by students in today's educational environment, including mounting workloads and pressures. Students are empowered with effective learning strategies by optimizing time utilization through intelligent scheduling, task management, and performance analysis. Furthermore, AI-powered chatbots and virtual mentors are crucial in offering emotional support, effectively reducing students' anxiety levels. Ethical considerations such as data privacy, algorithmic bias, and equitable access to AI tools are addressed. Collaboration among educational institutions, policymakers, and researchers is emphasized as vital to harnessing AI's power for a positive and inclusive learning environment. This research article contributes to the growing body of knowledge on AI's impact on education, providing valuable insights for further exploring and implementing AI-driven solutions in educational settings.

*Keywords:* AI in Education, Student Productivity, Stress Reduction, Educational Technology

### INTRODUCTION

Integrating artificial intelligence (AI) applications like ChatGPT has revolutionized students' learning experience, significantly boosting their productivity. Through AI-powered tools, students now benefit from personalized assistance and tailored guidance that meets their unique educational needs. This personalized approach enhances comprehension and efficiency, leading to improved academic performance. Moreover, instant feedback and real-time support are crucial in reducing stress levels, enabling students to tackle challenges effectively. AI also simplifies laborious tasks like research, organization, and proofreading, allowing students to allocate more time to critical thinking and nurturing their creativity (Mondal, 2023).

Ultimately, AI empowers students to thrive academically by fostering a balanced and highly productive learning environment. The applications of AI in education, healthcare, and design also have the potential to create employment opportunities for new workers. Existing evidence suggests that many students, including those with specific learning disabilities, can benefit from individualized education programs and personalized instruction. AI technologies hold tremendous potential to address these needs effectively and improve the overall educational experience (Fauzi, Tuhuteru, et al., 2023).

Artificial intelligence (AI) has emerged as a transformative force across various domains, revolutionizing industries and impacting daily lives. AI technologies offer tremendous educational potential to enhance student learning experiences, improve productivity, and alleviate stress. As students face mounting academic pressures, finding effective strategies to support their well-being and optimize their performance becomes imperative (Morales-Rodríguez, Martínez-Ramón et al., 2021). The study also provided evidence that younger individuals who rely more on negative self-focus, open emotional expression, and avoidance coping strategies while having lower levels of resilience experience higher stress levels. Conversely, older individuals who employ problem-solving techniques and positive re-evaluation tend to exhibit reduced stress levels. The study also identified that 23.7% of participants experienced stress during the pandemic, with no significant differences observed between the pre-and post-confinement periods. Additionally, the study showcased the potential of artificial neural networks to achieve substantial predictive power in stress detection.

Another study (Zawacki-Richter, Marín et al. 2019) found that AI in education (AIEd) research is predominantly led by authors from the United States, China, Taiwan, and Turkey, who significantly contribute to the field. Most of these publications (62%) originate from Computer Science and STEM departments. The applications highlighted in this article offer significant pedagogical opportunities for creating intelligent systems that assist students while facilitating adaptive and personalized learning environments. This is especially beneficial for large higher education institutions, such as open and distance teaching universities, where AIEd can help address the challenge of providing access to higher education for many students. Furthermore, AIEd can aid in delivering flexible, interactive, and personalized learning experiences, relieving teachers from onerous tasks like grading

a substantial volume of assignments. As a result, teachers can concentrate on their core responsibility of providing empathetic human teaching.

Integrating AI in education offers new opportunities for personalized and adaptive learning. AI-powered educational tools can analyze student data and preferences to tailor instructional content, pacing, and feedback, promoting student engagement and addressing individual learning needs, ultimately enhancing productivity (Acemoglu & Restrepo, 2018). Moreover, AI algorithms can provide intelligent support, helping students manage their time, organize tasks, and make informed decisions about their learning strategies. These support systems have shown promising results in reducing student stress and increasing efficiency (Mittal, Mahendra, et al., 2022). Automating administrative tasks is another area where AI can enhance productivity and reduce student stress. AI-based systems can streamline grading, scheduling, and course management, freeing educators.

## MATERIAL AND METHODS

### The PRISMA Guidelines

The PRISMA guidelines refer to the Preferred Reporting Items for Systematic Reviews and Meta-Analyses. These guidelines were published in 2009 (Moher, Liberati et al. 2009) to address the issue of poor reporting in systematic reviews. The PRISMA guidelines consist of a checklist of 27 items recommended for reporting in systematic reviews and an accompanying "explanation and elaboration" paper that provides additional guidance and examples for each item. These guidelines have gained wide acceptance and adoption in the scientific community, with endorsement from numerous journals, organizations, and disciplines. They are designed to improve the completeness and transparency of reporting in systematic reviews (Stewart, Tenenbaum et al. 2020).

### Search Strategy

In order to conduct a comprehensive systematic literature review on the utilization of Artificial Intelligence (AI) in education, an extensive search of electronic databases was performed. This search aimed to identify relevant articles published between 2017 and 2023. Specifically, the inclusion criteria were studies describing how AI tools enhance students' productivity and alleviate stress. These studies must be published in peer-reviewed journals and written in English within the abovementioned timeframe.

Conversely, studies were excluded from this review if they did not focus on applying AI tools to improve student productivity and reduce stress, were not published in English or a peer-reviewed journal, or were published before 2017. Ultimately, 15 articles met the inclusion criteria and are detailed in Table 1.

The search strings were formulated to address the research questions using the Boolean operator (limited to AND and OR) on Google Scholar, Inderscience, and connectedpapers.com databases. The search string used in Google Scholar was as follows: "Artificial intelligence" AND "education" AND "student productivity" AND "stress reduction". For Inderscience, the search string employed was: "AI in education" AND "student well-being" AND "AI tools for student performance" AND "managing student workload with AI". Lastly, the search string used in connectedpapers.com was: "Artificial intelligence in education" AND "chatbots in student support" AND "AI-driven solutions for student productivity" AND "integrating AI in universities for stress reduction". These search strings were devised to retrieve relevant literature on artificial intelligence's impact on enhancing student productivity and reducing stress among students in educational contexts.

### Selection Criteria

The systematic review followed the PRISMA guidelines for systematic reviews and meta-analyses to analyze the most relevant articles. The initial search across Google Scholar (634 articles), Inderscience (287 articles), and Connectedpapers.com (87 articles) yielded a total of 1,008 articles, including duplicates. After excluding 283 articles published in non-English, chapters from books or book series, and records unrelated to the educational field, 725 articles remained for eligibility screening. Duplicates were also removed, accounting for 229 records. During the screening process, 496 articles were considered, which led to the exclusion of 481 articles as they were deemed irrelevant to the research question or did not match the predefined keywords. Finally, the systematic review selected 15 articles that met the inclusion criteria for further analysis and synthesis. The flowchart detailing the processes involved in retrieving relevant articles using PRISMA guidelines is shown in Figure 1.



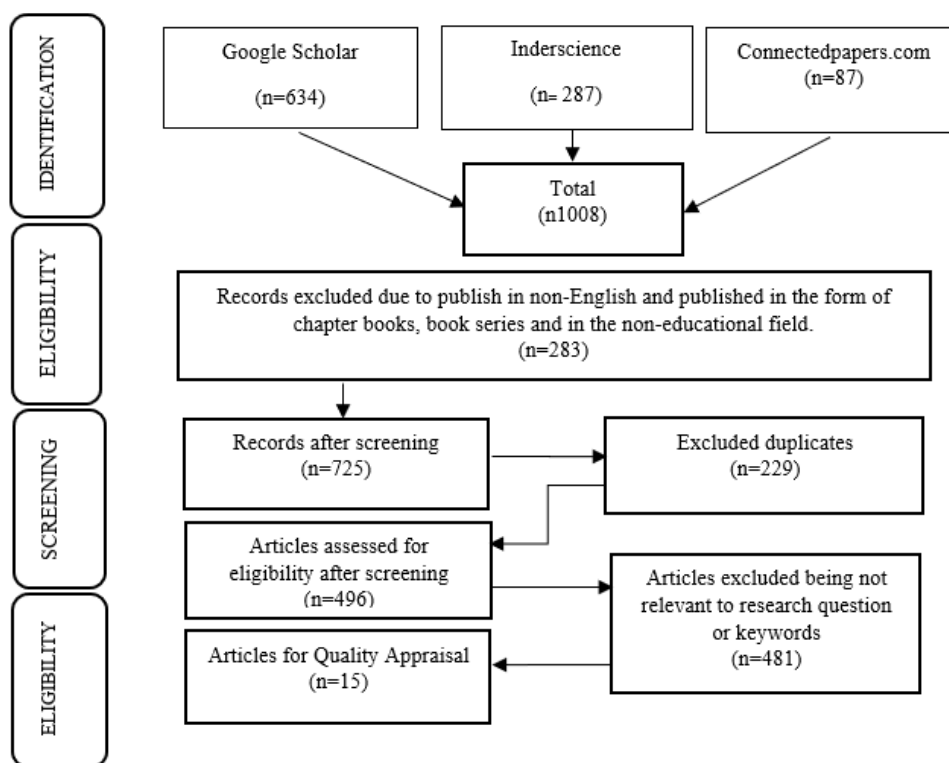



Figure 1: Flow chart detailing PRISMA guidelines for selecting relevant articles.

Table 1: Articles included in this review

No	Title	Authors	Year	Journal	Research model	Methodology	Conclusion
1	Stress, Coping, and Resilience Before and After COVID-19: A Predictive Model Based on Artificial Intelligence in the University Environment	Francisco Manuel Morales-Rodríguez1 , Juan Pedro Martínez-Ramón2 *, Inmaculada Méndez2 and Cecilia Ruiz-Esteban2	2021	Educational Psychology, a section of the journal Frontiers in Psychology		This study employed a quantitative approach and a transversal, ex post facto design.	AI language models like ChatGPT transform human-machine interactions.  Continuous development enhances efficiency and enables applications across various domains.
2	Artificial Intelligence, Automation, and Work	Daron Acemoglu and Pascual Restrepo	2019	Brookings Papers on Economic Activity	The article utilizes an empirical research approach, potentially drawing on economic models, statistical analysis, and data to explore the impact of AI and automation on work and labor market outcomes.	Combination of theoretical and empirical analysis	Automation can lead to the displacement of workers from tasks that machines can perform.  The extent of displacement will depend on several factors, including the workers' skill level, the automation cost, and the availability of complementary inputs.  Policymakers need to be aware of the potential risks associated with automation and take steps to mitigate these risks.

3	Artificial intelligence and sustainable development	Margaret A. Goralski	2020	The international journal of Management Education	Implementation Research Logic Model	Qualitative analysis of three case studies to draw inferences and lessons for management education and leadership development	AI offers game-changing opportunities for sustainable development across different sectors and countries.  Implementing AI-enabled solutions can drive economic development while addressing environmental and societal impacts.  However, careful management and partnerships are crucial to mitigate risks and maximize the positive impact of AI on sustainability.
4	Attitudes and perceptions of UK medical students towards artificial intelligence and radiology: a multicentre survey	Cherry Sit	2019	Insights into Imaging	variety of models to analyze the data collected from the survey	cross-sectional survey design	The study indicates that the perception of AI potentially replacing radiologists is discouraging many UK medical students from considering a career in radiology, which could have detrimental workforce consequences given the existing shortage of radiologists in the UK.
5	Effects of artificial intelligence on English speaking anxiety and speaking performance : A case study	Reham El Shazly	2021	Expert Systems	Quasi-experimental pretest-posttest design	This study utilized a quasi-experimental mixed model design to investigate the impact of AI-driven applications on anxious Egyptian EFL learners, employing both qualitative analyses of anxiety patterns and quantitative analysis of pretest-posttest oral proficiency scores and FLCAS data.	The study results showed that the experimental group had significantly lower levels of English-speaking anxiety than the control group at the end of the intervention. This suggests that the AI chatbot intervention was effective in reducing English-speaking anxiety.
6	Medical students' attitude towards artificial intelligence: a multicenter survey	Daniel Pinto dos Santos University of Cologne	2018	European Radiology	Cross-sectional survey	The article's methodology involves a web-based questionnaire designed using SurveyMonkey and administered to undergraduate medical students at three major medical schools. The questionnaire consisted of various sections to	Undergraduate medical students know AI's potential applications and implications in radiology and medicine.  They do not worry about AI replacing human radiologists or physicians.  Including AI in medical training and education is recommended, with radiology playing a key role in educating students about these emerging technologies.

						assess the students' attitudes toward artificial intelligence (AI) in radiology and medicine.	
7	Artificial Intelligence in Education: A Review	LIJIA CHEN <sup>1</sup> , PINGPING CHEN	2020	IEEE Access	The research model used in this study involves a combination of descriptive analysis and a review of existing literature.	A qualitative research study	<p>The rise of AI in higher education requires universities to rethink teaching roles and pedagogical models.</p> <p>Ethical implications and the potential loss of human knowledge and perspectives due to AI monopolization should be examined.</p> <p>Embracing AI offers inclusive education and lifelong learning opportunities, but universities must prioritize core values and human skills like imagination and creativity.</p>
8	Exploring the Impact of artificial intelligence on Teaching and Learning in higher education	Stefan A. D. Popenici	2017	Research and Practice in Technology-Enhanced Learning	The research model used in the article is the Diffusion of Innovation (DOI) model.	Mixed-methods approach to gather and analyze relevant information, including academic literature, case studies, interviews, and potentially survey data.	<p>The rise of AI in higher education requires universities to rethink teaching roles and pedagogical models.</p> <p>Ethical implications and the potential loss of human knowledge and perspectives due to AI monopolization should be examined.</p> <p>Embracing AI offers inclusive education and lifelong learning opportunities, but universities must prioritize core values and human skills like imagination and creativity.</p>
9	A systematic review of research on artificial intelligence applications in higher education—where are the educators?	Olaf Zawacki-Richter	2019	International Journal of Educational Technology in Higher Education	<p>Systematic review</p> <p>A systematic review is a research method that uses a rigorous and systematic process to identify, evaluate, and synthesize research evidence on a specific topic. In this case, the authors used a systematic review to identify and synthesize research on using artificial intelligence (AI) in higher education.</p>	The study used a systematic review method.	<p>There is a lack of critical reflection on the challenges and risks associated with AI in education (AIEd).</p> <p>The weak connection between AIEd and theoretical and pedagogical perspectives suggests more arrangement is needed. Further exploration of ethical and educational approaches is necessary to ensure the responsible and effective implementation of AIEd in higher education.</p>

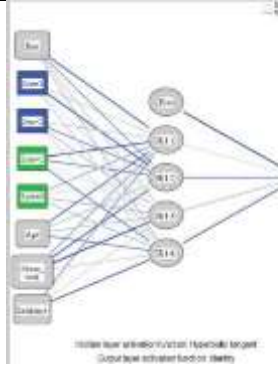
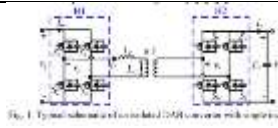
10	Self-Esteem at University: Proposal of an Artificial Neural Network Based on Resilience, Stress, and Sociodemographic Variables	Juan Pedro Martínez-Ramón	2022	Frontiers in Psychology		The study analyzed self-esteem levels in university teaching staff and students using surveys. It employed artificial neural networks to predict self-esteem based on coping strategies, resilience, and sociodemographic variables.	Resilience and perceived stress were found to be significant predictors of self-esteem levels.  The study highlights the potential of artificial neural networks in predicting psychological variables in education.
11	Artificial-Intelligence-Based Triple Phase Shift Modulation for Dual Active Bridge Converter with Minimized Current Stress	Xin Li	2021	IEEE JOURNAL OF EMERGING AND SELECTED TOPICS IN POWER ELECTRONICS		The study proposes an AI-based TPS modulation (AITPSM) strategy for the dual active bridge (DAB) converter using a neural network (NN) and fuzzy implication system (FIS).	The AI-TPSM approach effectively optimizes TPS modulation in the DAB converter, reducing everyday stress. Experimental verification with a 1 kW prototype confirms its effectiveness.
12	What should medical students know about artificial intelligence in medicine?	Seong Ho Park	2019	Journal of Educational Evaluation for Health Professions	Deep learning models	The methodology of the article is not explicitly mentioned	AI has the potential to significantly impact medicine and improve healthcare, addressing weaknesses in current practices.  Healthcare professionals and students must discern AI information accurately and generate reliable patient content.
13	Stress Prediction in Working Employees Using Artificial Intelligence of Things	SUHAS KS	2022	Journal of Pharmaceutical Negative Results	KNN, Decision tree, Naive Bayes	The methodology used in this article involves data collection, data preparation, data splitting, model training using machine learning algorithms, and stress prediction based on IoT sensor inputs.	The article concludes that machine learning techniques, particularly the KNN algorithm, can predict stress in working employees based on real-time parameters, emphasizing the importance of mental health benefits and the potential for further investigation using deep learning techniques.
14	How can machine learning be used in stress management : A systematic literature review of applications in	Shivani Mittal, Sumedha Mahendra, Viraj Sanap, Prathamesh Churi	2022	International Journal of information management data insights	Linear discriminant analysis (LDA)  Support vector machines (SVM)  Decision trees  Random forests  Neural networks	The text uses the Convolutional Neural Network (CNN) to measure college students' psychological stress and the Long Short-Term Memory (LSTM) network for mood prediction.	Machine learning techniques are crucial for predicting and managing stress across different sectors, including education, industry, and healthcare, to improve well-being and address the impact of stress in modern society.

	workplaces and education						
15	Analyzing the Role of ChatGPT in Improving Student Productivity in Higher Education	Fauzi1, Laros Tuhuteru2,	2023	Journal on Education	ChatGPT A large language model chatbot developed by OpenAI	The methodology involved desk research using secondary sources, literature sourcing, qualitative data collection, data reduction, presentation, and conclusion to understand the literature study comprehensively.	ChatGPT can significantly improve student productivity by providing information, resources, language skills improvement, collaboration facilitation, time efficiency, and support. However, it should be used wisely, together with human interaction and students' hard work, with suggestions for integrity assessment, balanced implementation, and continuous improvement of language models.

## DISCUSSION

The findings of this systematic literature review provide valuable insights into how artificial intelligence (AI) can have a profound impact on students' productivity and stress levels. After thoroughly reviewing 15 articles, we uncovered significant aspects and insights that highlight the potential benefits of AI in education as shown in Figure 2.

### Personalized Learning and Academic Support

AI-powered educational tools have the potential to revolutionize traditional education by personalizing the learning experience. By analyzing student data and preferences, AI algorithms can customize instructional content, pacing, and feedback, promoting student engagement and addressing individual learning needs. This personalized approach improves comprehension, efficiency, and academic performance. Integrating AI in education also enables intelligent support, assisting students in managing their time, organizing tasks, and making informed decisions about their learning strategies. These support systems have shown promising results in reducing student stress and increasing efficiency.

### Automation of Administrative Tasks

One significant way AI enhances productivity and reduces student stress is by automating laborious administrative tasks. AI-based systems streamline grading, scheduling, and course management, freeing educators from time-consuming activities. This automation improves efficiency and alleviates stress by reducing student workload. Educators can then focus more on teaching and providing individualized support to students.

### Emotional Support and Stress Reduction

AI-driven chatbots and virtual mentors offer valuable emotional support to students, significantly alleviating anxiety and stress levels. These chatbots provide real-time assistance, answer questions, and offer guidance on various academic and personal challenges. The availability of immediate support helps students overcome obstacles and build resilience, contributing to their overall well-being. Moreover, AI tools can detect stress patterns and provide early intervention strategies, allowing for timely support and prevention of stress-related issues.

### Ethical Considerations

While AI presents numerous benefits, ethical considerations must be addressed to ensure responsible and equitable implementation. Data privacy, algorithmic bias, and equitable access to AI tools are crucial concerns. It is essential to safeguard student data and ensure its confidentiality to maintain trust in AI systems. Efforts should be made to minimize algorithmic bias and ensure fairness in AI-driven educational interventions. Bridging the digital divide and providing equal access to AI tools, particularly for disadvantaged students, is important for creating an inclusive learning environment.

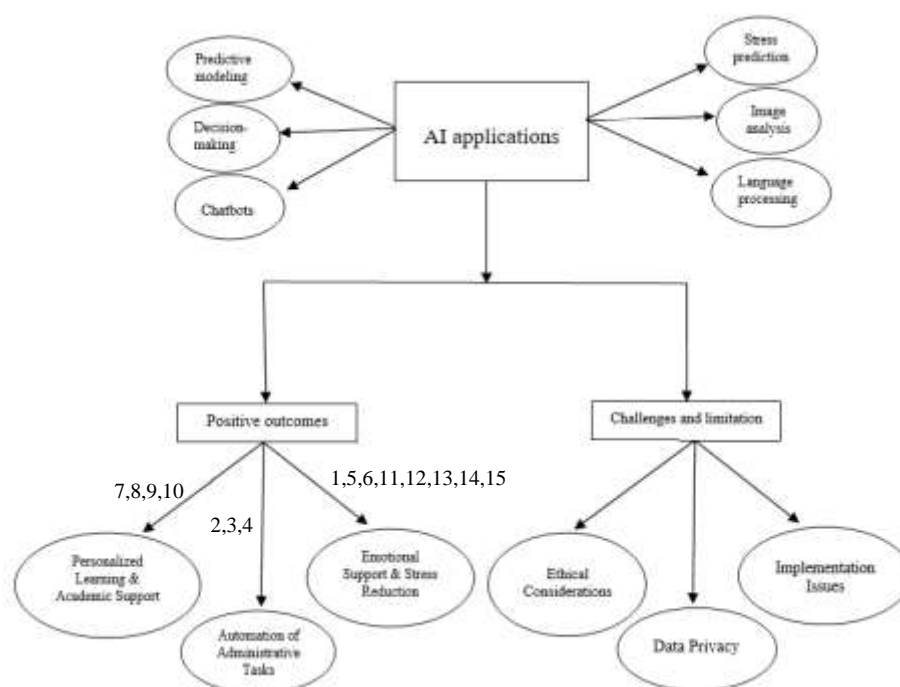

Figure 2 Key Findings and Cause-Effect Relationships of AI Applications in Education

### CONCLUSION

The impact of artificial intelligence (AI) in enhancing productivity and reducing stress among students is evident from the findings of this systematic literature review. The analysis of 15 articles highlights the potential of AI-powered educational tools to revolutionize traditional education paradigms. Personalized learning experiences, automation of administrative tasks, and provision of emotional support contribute to improved academic performance and student well-being. However, ethical considerations such as data privacy, algorithmic bias, and equitable access must be addressed to ensure AI's responsible and inclusive implementation in education.

Collaboration among educational institutions, policymakers, and researchers is vital to harnessing the power of AI for a positive and inclusive learning environment. Further exploration and implementation of AI-driven solutions in educational settings are warranted to fully realize the benefits of AI in enhancing student productivity and well-being. By leveraging AI technologies effectively, educational systems can support students in overcoming challenges, reducing stress, and fostering a highly productive and balanced learning environment.

Future research in artificial intelligence (AI) and education should focus on several key areas. Long-term studies are needed to understand the sustained effects of AI interventions on student productivity and stress reduction. Investigating student engagement and motivation in the context of AI technologies can optimize their use in educational settings. Ethical implications must be addressed for responsible implementation, including data privacy and algorithmic bias. Understanding the attitudes and perceptions of students and teachers toward AI in education can inform effective strategies. Additionally, exploring the effectiveness of AI interventions for special student populations and promoting student well-being and mental health are important areas for further investigation.

### ACKNOWLEDGEMENT

This research was partially supported by the Ministry of Science and Technology in Taiwan (Grant No. 111-2410-H-194-029-MY2 and 112-2410-H-194-029-MY3).

### REFERENCES

- Acemoglu, D., & Restrepo, P. (2018). Artificial intelligence, automation, and work. In *The economics of artificial intelligence: An agenda* (pp. 197-236). University of Chicago Press.
- Chen, L., Chen, P., & Lin, Z. (2020). Artificial intelligence in education: A review. *IEEE Access*, 8, 75264-75278.
- El Shazly, R. (2021). Effects of artificial intelligence on English speaking anxiety and speaking performance: A case study. *Expert Systems*, 38(3), e12667.
- Fauzi, F., Tuhuteru, L., Sampe, F., Ausat, A. M. A., & Hatta, H. R. (2023). Analyzing the role of ChatGPT in improving student productivity in higher education. *Journal on Education*, 5(4), 14886-14891.
- Goralski, M. A., & Tan, T. K. (2020). Artificial intelligence and sustainable development. *The International Journal of Management Education*, 18(1), 100330.

- KS, S., & HD, P. (2022). Stress Prediction in Working Employees using Artificial Intelligence of Things. *Journal of Pharmaceutical Negative Results*, 2024-2029.
- Kooli, C. (2023). Chatbots in education and research: A critical examination of ethical implications and solutions. *Sustainability*, 15(7), 5614.
- Loglo, F. S., & Zawacki-Richter, O. (2023). Learning with Digital Media: A Systematic Review of Students' Use in African Higher Education. *Journal of Learning for Development*, 10(1), 1-23.
- Mittal, S., Mahendra, S., Sanap, V., & Churi, P. (2022). How can machine learning be used in stress management: A systematic literature review of applications in workplaces and education. *International Journal of Information Management Data Insights*, 2(2), 100110.
- Moher, D., et al. (2009). "Preferred reporting items for systematic reviews and meta-analyses: the PRISMA statement (Chinese edition)." *Journal of Chinese Integrative Medicine*, 7(9), 889-896.
- Morales-Rodríguez, F. M., Martínez-Ramón, J. P., Méndez, I., & Ruiz-Esteban, C. (2021). Stress, coping, and resilience before and after COVID-19: A predictive model based on artificial intelligence in the university environment. *Frontiers in Psychology*, 12, 647964.
- Mondal, S., Das, S., & Vrana, V. G. (2023). How to bell the cat? A theoretical review of generative artificial intelligence towards digital disruption in all walks of life. *Technologies*, 11(2), 44.
- Park, S. H., Do, K. H., Kim, S., Park, J. H., & Lim, Y. S. (2019). What should medical students know about artificial intelligence in medicine?. *Journal of educational evaluation for health professions*, 16.
- Pinto dos Santos, D., Giese, D., Brodehl, S., Chon, S. H., Staab, W., Kleinert, R., ... & Baeßler, B. (2019). Medical students' attitude towards artificial intelligence: a multicentre survey. *European radiology*, 29, 1640-1646.
- Popenici, S. A., & Kerr, S. (2017). Exploring the impact of artificial intelligence on teaching and learning in higher education. *Research and Practice in Technology Enhanced Learning*, 12(1), 1-13.
- Sit, C., Srinivasan, R., Amlani, A., Muthuswamy, K., Azam, A., Monzon, L., & Poon, D. S. (2020). Attitudes and perceptions of UK medical students towards artificial intelligence and radiology: a multicentre survey. *Insights into imaging*, 11, 1-6.
- Stewart, S. K., et al. (2020). "Fracture union rates across a century of war: a systematic review of the literature." *BMJ Mil Health*, 166(4), 271-276.
- Zawacki-Richter, O., Marín, V. I., Bond, M., & Gouverneur, F. (2019). Systematic review of research on artificial intelligence applications in higher education—where are the educators?. *International Journal of Educational Technology in Higher Education*, 16(1), 1-27.



## **Influence of Social Media Platforms on Consumers' Attitudes for Selecting Travel Destinations**

Vandana Ahuja<sup>1</sup>  
Pooja Sehgal Tabeck<sup>2</sup>  
Prerna Arora<sup>3,\*</sup>

\*Corresponding author

<sup>1</sup> Director and Professor, Symbiosis Institute of Business Management, Symbiosis International University, Noida, India, director@sibmnoida.siu.edu.in

<sup>2</sup> Assistant Professor, Symbiosis Institute of Business Management, Symbiosis International University, Noida, India, pooja.tabeck@sibmnoida.siu.edu.in

<sup>3</sup> Research Scholar, Amity Business School, Amity University Uttar Pradesh, India, prerna.aarora97@gmail.com

### **ABSTRACT**

The utilisation of social media platforms has emerged as an essential tool for attaining success in the modern business environment. The primary objective of this research endeavour is to examine the possible inclination of individuals towards utilising Instagram as a means to choose a travel destination. The present study is predicated upon a self-administered survey conducted among a sample size of 242 individuals. According to the findings derived from the regression analysis, it can be concluded that the Tour Operator Generated Content (TOGC) holds the highest level of significance regarding its impact on the explanation of variance in individuals' attitudes towards destination selection. The present study's findings offer significant insights for marketers and businesses in the travel industry.

*Keywords:* social media, tourist decision-making, electronic word of mouth, user-generated content, social media engagement

### **INTRODUCTION**

The tourism industry plays a vital role in the economic development of numerous countries globally. This industry consistently generates revenue and enhances the nation's financial stability. Travel and tourism have transformed from mere transportation between locations to becoming a lifestyle. People seek novel experiences and adventures, such as discovering unfamiliar urban areas, sampling local gastronomy, and engaging in cultural pursuits. Travelling has increasingly become a means for individuals to seek respite, find relaxation and escape the pressures of their daily routines. Many individuals visit tourist destinations with their friends and family during holidays and festivals, increasing the tourism industry's popularity. People often choose to travel as a means of escaping from work. However, it is important to consider how individuals select their travel destinations. Travelling to new destinations with friends and family has become a popular trend.

The tourism industry in India plays a substantial role in the country's economy and provides employment opportunities for many individuals. India attracts tourists from various countries due to its diverse culture, rich history, natural beauty, and architectural marvels. India is renowned for its significant diversity, characterised by distinct variations in history and culture across different regions (Nayak et al., 2023). The variety of vacation destinations in India reflects the country's overall diversity. With its vast cultural diversity and natural splendour, India presents abundant opportunities for exploration and adventure. In recent years, the travel and tourism sector has experienced significant growth in popularity as a leisure activity worldwide.

The accessibility and convenience of travel planning and booking have significantly improved due to technological advancements and the widespread use of the Internet. The availability of diverse travel options and destinations has facilitated the customisation of vacations to suit individual preferences and interests. The rapid growth of the internet in recent years has sparked increased interest in travel among individuals seeking engaging and appealing activities tour (Gholamhosseinzadeh et al., 2023). The influence of social media has significantly grown with the emergence of the internet. The tourism industry is widely recognised as one of the most fiercely competitive sectors within the service industry. This field necessitates efficient management of various resources, including natural, financial, and human resources, available within a given country. The development of the tourism industry in any country necessitates providing appropriate infrastructure, enhancing service quality, and auguring customer satisfaction. The fundamental principle underlying effective marketing strategies revolves around providing substantial value to secure the loyalty and longevity of customers. In the marketing field, various instruments are employed with the primary objective of attaining customer satisfaction and loyalty. These instruments play a crucial role in shaping marketing strategies and ensuring the success of businesses. The utilization of social media platforms has become an indispensable tool for achieving success in the contemporary business landscape. Businesses' utilisation of social media platforms has garnered significant attention, as it offers a means for companies to establish direct and favourable relationships with their customers. The utilisation of the internet to book various services and accommodations has been observed to exhibit a positive

correlation with the level of internet penetration within a given country. Countries with higher internet penetration rates tend to demonstrate a greater propensity for utilising online platforms for booking purposes. Social media encompasses the actions of individuals within a community, involving the collection and dissemination of information and knowledge through online platforms. Social media is widely recognized by marketers as a potentially effective tool for generating sustainable and positive word-of-mouth marketing. Selecting an appropriate social media platform, crafting an effective message, and engaging the appropriate audience are crucial factors for the successful implementation of marketing campaigns. The Tourism Review Team collaborates with various media platforms daily to promote the tourism industry and attract visitors from different countries. The tourism and hospitality industry has witnessed the emergence of several prominent and impactful social media networks for marketing purposes. Among these, Instagram, Facebook, Twitter, YouTube, Podcasts, and travelshake have gained significant recognition and effectiveness. These platforms have proven to be valuable tools for promoting businesses and engaging with target audiences in the industry. The utilization and impact of social media marketing strategies play a significant role in meeting the demands of tourists worldwide (Pudliner, 2007). The advent and widespread availability of the internet have significantly transformed tourists' motivations for planning and booking trips to various destinations (Buhalis & Law, 2008). The increasing reliance of companies on the social web for travel research has enhanced confidence and familiarity in obtaining successful information from websites. The accessibility of new information technology has greatly transformed the creation and dissemination of information. Marketers can utilize social media platforms to promote customer interaction and enhance awareness of tourists within a specific country (Xiang et al., 2008).

Based on a comprehensive analysis of prior research studies, it has been determined that a subset of these investigations failed to focus exclusively on a singular social media platform, thereby presenting difficulties in formulating overarching conclusions pertaining to the entirety of social media. The present study aims to investigate the potential preference of individuals towards Instagram. Social media platforms are an important part of destination marketing strategies today because they give travellers the chance to talk about their trips in real time (Khan et al., 2022). Instagram has a lot of benefits for tourist locations, especially when money and marketing tools are limited (Zhang et al., 2020). As of January 2023, Instagram is the third most popular social networking site in the world, after Facebook and YouTube. It has 1478 million active users and is the first choice for marketing campaigns (advertising costs on Instagram are 60% higher than on other social media sites) (*Instagram Advertising and Marketing*, n.d.). Instagram is also well-known for being the first social media site that let users connect with each other as if they were real-life friends. This parasocial involvement, which happens when a viewer interacts with a character online in a way that builds a virtual/imagined and trusting relationship, has made Instagram one of the most popular sites for marketing. So, Instagram users with high engagement levels are seen as friends by their fans, which gives them a lot of power to persuade or influence (Campbell & Farrell, 2020).

## REVIEW OF LITERATURE

### Electronic Word of Mouth (e-WOM)

Word of mouth (WOM) refers to interpersonal communication when consumers engage in direct conversations on their experiences with a particular product or service (López & Sicilia, 2014). The face-to-face interaction often occurs in a private setting and involves two individuals: the provider of information and the recipient (Gilly et al., 1998). According to previous research (Büttner & Göritz, 2008), those who typically engage in communication exchanges as the source and recipient are commonly characterised as friends, family, or acquaintances. The primary attribute of word-of-mouth (WOM) is the independence of the source. The source of WOM has no economic incentive in disseminating this information.

Consequently, this communication mechanism is deemed more credible than information provided by firms (Arndt, 1967). The proliferation of emerging technologies has facilitated the dissemination of product-related information among customers via the Internet, thus amplifying the potential influence of word-of-mouth communication (Cheung & Thadani, 2012; Chevalier & Mayzlin, 2006). Electronic word-of-mouth (e-WOM) refers to the act of individuals, including future, current, or past consumers, expressing their opinions, whether favorable or bad, regarding a product or organization. These statements are disseminated to various individuals and organizations over the Internet. Various venues facilitate the expression of consumer opinions. The platforms that enable the production and sharing of user-generated content are commonly known as social media (Kaplan & Haenlein, 2010). Social media encompasses several online platforms, including blogs, review sites, social network sites, and forums. The incorporation of electronic word-of-mouth (e-WOM) holds significant importance in comprehending the realm of tourism marketing communications, as many customers are consistently motivated to disseminate their travel experiences with others through online platforms. The utilisation of this medium serves as an effective strategy to engage consumers and enhance the overall accessibility of the location to a broader range of visitors. The act of individuals sharing their personal travel experiences on online platforms, particularly Instagram, has proven to facilitate the planning process for other potential visitors. In contemporary society, the widespread availability of internet connectivity has granted individuals the ability to access and utilise various online platforms. Consequently, sharing personal experiences has become significantly more convenient and accessible. As a result, electronic word-of-mouth (e-WOM) has likely become more prevalent and effortless compared to previous eras. Thus, it is important to understand whether e-WOM plays an important role in consumers' attitudes towards using Instagram as a tool to select travel destinations.

### User Generated Content (UGC)

The recognition of user-generated content (UGC) in social media is increasingly evident in the existing body of research. Multiple studies have been conducted and published in the literature, highlighting this phenomenon. However, there is still a need for

further exploration and in-depth analysis of UGC in social media (Zeng & Gerritsen, 2014). UGC refers to the written content pertaining to a particular product, service, or experience that is created by customers of a brand. The impact of UGC in social media on the tourism sector's travelling process has been widely acknowledged (Nezakati et al., 2015). This impact encompasses various stages, including the pre-travel process, during travel, and the post-travel process. The influence of pre-travel period on both tourists and tourism enterprises is of significant importance. Research has shown that user-generated content (UGC) on social media platforms significantly provides tourism information. This information is valuable for tourists as it helps them in developing their travel plans and make informed decisions about their trips (Xiang & Gretzel, 2010). Moreover, UGC on social media is considered to be a highly reliable source of information, offering instant access to trustworthy content (Yoo et al., 2009; Yoo & Gretzel, 2011). The interactive nature of social media platforms allows users to not only search for information but also engage with others, leading to a wide dissemination of knowledge (Nezakati et al., 2015). When considering a destination for travel, it is important to conduct a comprehensive evaluation that considers various aspects. Previous research has identified bidirectional relationships between expectations and the image of a destination. Gartner (1989) discovered that forming an image can impact one's expectations of the experience. Similarly, (Mayo & Jarvis, 1981) found that expectations also play a significant role in shaping the image of a destination. During the pre-trip stage, the development of an image in the destination undergoes a multistage process. The formation of a traveler's perception of a destination can be influenced by various information sources that are not under the control of Destination Marketing Organisations (DMOs). Furthermore, it has been argued that the act of visiting a destination and gaining firsthand experience contributes to the ongoing development of the destination's image. In the process of making purchasing decisions, individuals typically generate expectations based on the information they receive regarding products or services. Expectations can be defined as the beliefs held by individuals regarding the characteristics of a product or service during the pre-purchase and pre-consumption stages. Upon receiving information from the UGC on social media platforms, tourists can make informed decisions regarding their travel destinations. This process allows them to develop specific expectations about the chosen destination and select a place that aligns most closely with their anticipated experiences. Moreover, following the disconfirmation of expectations theory, the variable of expectations will be employed in assessing tourist satisfaction through comparative judgement after the consumption of travel-related products and services. In the context of tourism, it is common for tourists to compare their preconceived expectations of a destination and their actual experiences upon arrival. This comparative analysis allows tourists to evaluate and assess the extent to which their initial perceptions align with the reality of their destination. However, it is important to note that expectations regarding destinations can vary significantly based on the unique characteristics of each destination.

#### **Tour Operator Generated Content (TOGC)**

Prior to the advent of the internet revolution, the tourism industry relied extensively on tour operators and travel agents as primary sources for the distribution of information and the sale of their products and services (Sultan et al., 2021). The emergence of Web 2.0 has given the tourism industry an opportunity to bypass intermediaries and establish direct communication with consumers, resulting in decreased managerial expenses (Buhalis & Licata, 2002). The advent of direct virtual communication has significantly contributed to the growth of the tourism industry. The adoption of this new interactive marketing tool for online marketing and communication with consumers has been observed in the tourism industry (Marine-Roig & Ferrer-Rosell, 2018). In recent years, the emergence of new technologies has significantly impacted the tourism industry. This has led to a growing trend among tour operators now utilising social media platforms to promote their services and businesses. The interest of travellers has been ignited and stimulated through the dissemination of informative presentations and persuasive content on various social media platforms. The success of tour operators' tourism businesses is now heavily influenced by online sales conversion and the exploration of travel information through social media (Mehmood et al., 2018). In addition to experiencing a surge in online visibility, social media platforms have emerged as a noteworthy source of travel information for tour operators. The researchers have focused on exerting influence on specific consumers by providing them with the opportunity to compare prices, make ticket purchases, and book accommodations via social media platforms. According to recent research, the advent of the internet has greatly impacted the way tour operators interact with their potential customers. The online presence, quality, and functionality of information have provided tour operators with a direct means of communication (Marine-Roig & Ferrer-Rosell, 2018).

The influence of diverse sources of information on the formation of travellers' destination image has been highlighted by multiple researchers (Senders et al., 2013; Tsiakali, 2018). (Um & Crompton, 1990) assert that the formation of a destination's cognitive and affective image is influenced not only by the marketing information disseminated by tourism authorities but also by social influence, specifically through recommendations from friends or family members. Tour operators are also interested in examining the influence of recommendations and opinions on travellers' intentions, as it pertains to their positive impact. In this particular scenario, it is imperative for tour operators to establish reliable sources of travel information. This can be achieved by utilising the interactive features of social media platforms, which can effectively enhance their competitive edge within the tourism industry (Stepchenkova & Mills, 2010). The integration of social media elements, characteristics, and capabilities has enabled tour operators to effectively disseminate travel information, promote their services, cultivate connections with specific consumer groups, and notably, construct a cognitive and emotional perception of destinations (Kim et al., 2017).

#### **Consumers' Attitudes towards using Instagram to select Travel Destinations and Decision-Making**

Limited research has been conducted on the impact of social media on tourists' selection of destinations. Most existing studies on social media and tourism primarily concentrate on smaller-scale decisions. Numerous studies provide evidence of the widespread use of social media in influencing destination choices across different countries and cultures. Social media plays a

significant role in influencing tourists' evaluation sets and their choice of shortlisted destinations (Tham et al., 2020). The identified level of influence was generally found to be low to very low. As suggested by previous studies, the absence of social media influence in accounting has been attributed to a lack of source credibility (Filieri et al., 2015; Tham et al., 2013). Several studies have found that social media can validate tourists' decisions and reduce cognitive dissonance, rather than directly influencing their choice (Cox et al., 2009; Fotis et al., 2011). Previous research studies have focused on a limited number of social media sites, market segments, and destinations (Simms, 2012). The existing research on the impact of social media on tourists' destination choice is limited in scope, which hinders its applicability to different contexts. The influence of social media on destination choices varies depending on different circumstances and contexts (Hua et al., 2017). Considering this, several key questions arise. The emphasis on a particular destination, as observed in most of the studies reviewed, may restrict the ability to recognise and comprehend influence. It is possible that certain participants in the study already had a prior connection with the destination, which could have diminished the impact of social media or any other communication channel (Kang & Namkung, 2016). Furthermore, it is worth considering whether the emphasis on particular social media platforms in existing studies restricts exploring the potentially significant impact that other social media platforms or alternative communication channels may have had. Tourists' destination decisions are influenced by various sources and channels (Book et al., 2018). Therefore, it is crucial to consider multiple interactions rather than focusing on just one or two, as this would underestimate their cumulative influence. The importance of considering context is emphasised in relation to the influence of social media on tourists' destination choices (Lee et al., 2018; Marder et al., 2019). Tourists frequently utilise social media platforms to acquire information and alleviate post-purchase dissonance. The significance of the tourist's destination choice has been largely overlooked or intentionally downplayed in previous research. According to destination choice studies, the influence of social media is expected to differ based on the decision-making context. Tourists frequently utilise social media platforms to get information and alleviate any potential cognitive dissonance that may arise after making a purchase. Nevertheless, the consideration of the tourist's location selection has been mostly overlooked or intentionally downplayed. According to research on destination choice, it is probable that the impact of social media would differ based on the specific environment of decision-making, as shown by Lee et al., (2018), (Marder et al., 2019) and (McCabe et al., 2016).

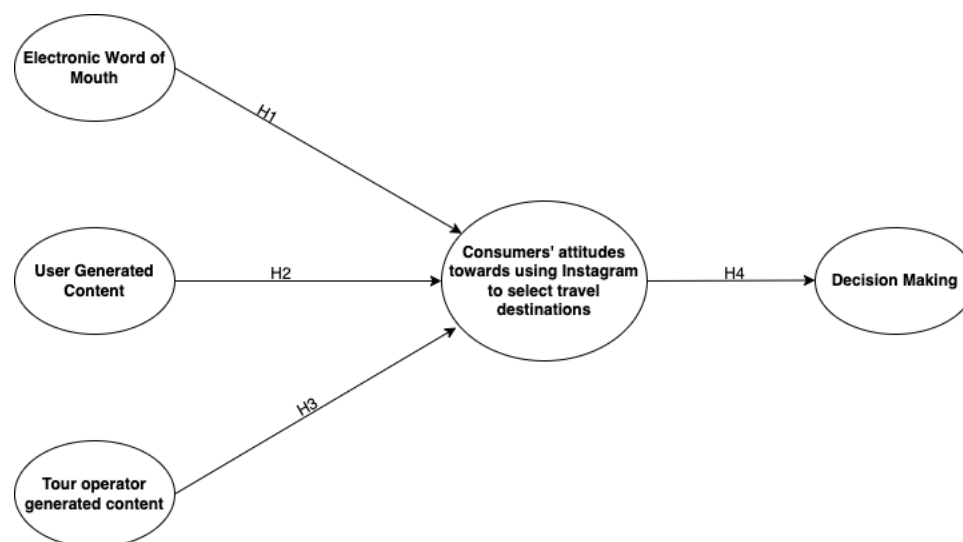

Figure 1: Conceptual Model

## RESEARCH OBJECTIVES

This study focuses on the following objectives:

- 1.1 To explore the potential preference of consumers towards Instagram.
- 1.2 To study the impact of Instagram on individuals' travel decision-making processes.
- 1.3 To examine the effectiveness of Instagram as a social media platform in promoting travel destinations.
- 1.4 To study consumers' attitudes towards utilizing Instagram to select their desired travel destinations.

## RESEARCH METHODOLOGY

### Participants and Procedure

The sample population for the current study was made up of an Indian audience from the NCR area. The sample was acquired to completely understand how Consumers' attitudes are impacted by factors such as Electronic word of mouth, user-generated content and tour operator-generated content. Furthermore, the sample also helped to understand how consumers attitudes help them to make a decision regarding their travel destinations. The cross-section survey design was used in conjunction with the convenience sampling strategy. Data from the survey was gathered using online self-administered questions circulated through Google Forms. Such online questionnaires are increasingly frequent in quantitative research (Selm & Jankowski, 2006). The sample size for the study was 242 respondents. The demographic makeup of the sample is shown in Table 1. The data was analysed using PSPP software to find the influence of independent variables on dependent variables.

Table 1: Demographics

	Category	Sum	Percentage
Gender	Male	110	45.5
	Female	132	54.5
Age	Below 21	10	4.10
	21-30	148	61.2
	31-40	67	27.7
	41-50	13	5.4
	51 and above	4	1.7
Educational Qualification	High School	2	0.8
	Graduation	40	16.5
	Post- Graduation	169	69.8
	Professional Degree	31	12.8
Occupation	Student	70	28.9
	Employed	126	52.1
	Unemployed	2	0.8
	Self-employed	44	18.2
Frequency of using Instagram	Daily	4	1.7
	Once a week	62	25.6
	Bi-Monthly	18	7.4
	Monthly	158	65.3

**Measures**

The independent variables, i.e., electronic word of mouth, tour operator-generated content, user-generated content, and dependent variable, attitude were measured in the study. Again, to understand the impact of attitude on decision-making, attitude is the independent variable, and decision-making is the dependent variable.

**HYPOTHESIS**

- H1: There is a significant relationship between e-WOM and consumers’ attitudes towards using Instagram as a tool to select travel destinations.
- H2: There is a significant relationship between UGC and consumers’ attitudes towards using Instagram as a tool to select travel destinations.
- H3: There is a significant relationship between TOGC and consumers’ attitudes towards using Instagram as a tool to select travel destinations.
- H4: There is a significant relationship between consumers’ attitudes towards using Instagram as a tool to select travel destinations and their decision-making.

**DATA ANALYSIS AND FINDINGS**

**Reliability of Research Constructs**

Table 2: Cronbach Alpha

Cronbach's Alpha	No. of Items			
0.78	5			
Table 3: Mean, Variance, Correlation, Cronbach’s Alpha				
	Scale Mean	Scale Variance	Total Correlation	Cronbach's Alpha
<b>TOGC</b>	34.79	72.83	0.53	0.74
<b>UGC</b>	33.88	79.21	0.46	0.77
<b>Attitude</b>	34.53	67.45	0.71	0.69

<b>e-WOM</b>	32.05	78.16	0.33	0.81
<b>DM</b>	29.6	50.05	0.81	0.63

A reliability test assesses the degree of consistency or stability exhibited by a measure when applied to different raters or items, such as a survey or questionnaire. The presented table displays the Cronbach's Alpha coefficient value of 0.78, indicating a high level of internal consistency for the components utilized. A reliability test was conducted to assess the dependability of participants' responses to the study instruments. In survey-based research, the accuracy and clarity of respondents' answers play a pivotal role in assessing the reliability and validity of the collected data. Hence, it is evident that when subjecting the dataset to a reliability assessment, it was ascertained that all variables in the research possess Cronbach's alpha coefficients exceeding the threshold of 0.7.

Table 4: Correlation

		TOGC	UGC	e-WOM	ATTITUDE	DECISION MAKING
TOGC	Pearson Correlation	1				
	P-value					
UGC	Pearson Correlation	.234	1			
	P-value	.000				
e-WOM	Pearson Correlation	.351	.215	1		
	P-value	.000	.011			
ATTITUDE	Pearson Correlation	.458	.367	.253	1	
	P-value	.000	.000	.000	.000	.000
DECISION MAKING	Pearson Correlation	.747	.593	.667	.744	1
	P-value	.000	.000	.000	.000	.000

In the table above, it was found that tour-generated content (TOC) has a statistically significant positive effect on how people feel about using Instagram to choose a location (Attitude). The fact that  $r_{242} = 0.458$ , and  $p = .05$  shows a significant link between the two given factors led to the null hypothesis being rejected and the alternative hypothesis being accepted. Based on the data, it's clear that user-generated content (UGC) has a moderately good effect on how people feel about using Instagram to choose a destination (Attitude). [ $r_{242} = .367$ ,  $p = .05$ ], which shows that there is a significant relationship between UGC and how customers feel about using Instagram as a tool to choose a destination. This means the null hypothesis is rejected, and the alternative hypothesis is accepted. The study also investigated to see if there was a link between e-Word of Mouth (e-WOM) and how consumers felt about using Instagram as a tool to choose a destination. The correlation between the two showed a weakly positive link between the two where  $r_{242} = 0.253$ ,  $p = 0.05$ . The null hypothesis was rejected. The study also found a high positive correlation between how consumers and TOGC feel about using Instagram to choose a place and make a choice (DM), [ $r = .744, .747$ ]. The table shows that there is a moderate link between UGC, e-WOM, and making decisions [ $r = .593, .667$ ].

**Multiple Regression Analysis**

First the regression analysis is computed on UGC, e- WOM and attitude. Where UGC, TOGC and e-WOM are independent variables and attitude is the dependent variable.

Second regression analysis is conducted on attitude towards using Instagram as an instrument to select the destination and decision making. Here, the independent variable is the attitude of the consumers and decision making is a dependent variable.

**Effect of e-WOM, UGC and TOGC on attitude towards Instagram in selecting the travel destination.**

Table 5: Model Summary (Attitude)

<b>R</b>	<b>R Square</b>	<b>Adjusted R Square</b>	<b>Std. Error of the Estimate</b>
0.54	0.29	0.28	2.14

The adjusted r square value,  $r^2 = .28$  shows that the multiple linear regression model could account for about 28% of the variation in customers' attitudes on utilizing Instagram to choose their travel destination.

Table 6: ANOVA (Attitude)

	Sum of Squares	df	Mean Square	F	Sig.
Regression	438.7	3	146.23	32.05	0
Residual	1085.8	238	4.56		
Total	1524.5	241			

F statistic and p-value is a test of significance for the entire regression. Inferring  $p=.000$  from the data, this regression model is statistically significant since  $p<.05$ .

Table 7: Coefficients (Attitude)

	Unstandardized Coefficients		Standardized Coefficients	t	Sig.
	B	Std. Error	Beta		
(Constant)	1.52	0.61	0	2.48	0.014
TOC	0.35	0.06	0.36	6.09	0
UGC	0.3	0.06	0.27	4.78	0
eWom	0.08	0.05	0.09	1.53	0.127

Regression results in the above table show that both TOGC and UGC have a significant influence on the value of attitude ( $\beta =.36$ ,  $\beta=.27$ ;  $p<.05$ ). Similarly, the data shows that the e-WOM factor does not significantly influence the attitude of consumers towards using Instagram in choosing the destination ( $\beta=.09$ ;  $p=.127$ ). According to the study, TOGC has the highest effect on explaining variances in Attitude.

**Effect of Attitude on Decision Making of the Consumers**

Table 8: Model Summary (DM)

R	R Square	Adjusted R Square	Std. Error of the Estimate
0.86	0.75	0.75	1.78

The adjusted r square value,  $r^2 =.55$ , shows that the multiple linear regression model could account for about 55% of the variation in the consumers' decision-making while selecting the destination.

Table 9: ANOVA (DM)

	Sum of Squares	df	Mean Square	F	Sig.
Regression	2235.52	1	2235.52	705.98	0
Residual	759.97	240	3.17		
Total	2995.49	241			

F statistic and p-value is a test of significance for the entire regression. Inferring  $p=.000$  from the data, this regression model is statistically significant since  $p<.05$ .

Table 9: Regression

	Unstandardized Coefficients		Standardized Coefficients	t	Sig.
	B	Std. Error	Beta		
(Constant)	3.52	0.33	0	10.82	0
Attitude	1.21	0.05	0.86	26.57	0

Regression results in the above table show that attitude significantly in the value of attitude as ( $\beta =.74$ ;  $p<.05$ ). Hence, H1 to H3 are accepted, i.e., the relationship between consumers' attitudes and UGC, and the relationship between consumers' attitudes and TOGC. Also, they have a direct positive effect on attitudes towards choosing a travel destination through Instagram. On the other hand, H1 is not accepted as the significant value is more than 0.05. Even attitude has a positive effect on decisions; therefore, H4 will be accepted.



## DISCUSSIONS AND CONCLUSIONS

The advent of social media has ushered in a new era in which individuals have come to expect the ready availability of information online, accessible to individuals worldwide at no cost. In contemporary times, it has become increasingly imperative for every sector to establish a presence on at least one social media platform. The primary objective behind this research is to effectively disseminate information pertaining to their respective services and products to a wide-ranging audience. This study is an investigation into the various factors that influence consumers' attitudes towards utilising Instagram as a means of selecting a travel destination. The aim of this research was to shed light on the relationship between these factors and consumer behaviour, ultimately providing valuable insights for marketers and businesses operating within the travel industry. The significance of tour operators' content in trip decision-making is a crucial factor to consider. The study of consumer behaviour reveals that individuals frequently turn to the content shared by operators on the popular social media platform, Instagram. The establishment of trust between consumers and tour operators is crucial in ensuring the successful delivery of exceptional travel experiences. In this regard, tour operators can enhance their credibility by providing detailed information and insights into the trips they have previously organised. This research paper aims to explore the impact of such transparency on consumer trust and its subsequent influence on the perceived ability of tour operators to deliver exceptional experiences. The analysis of correlation revealed a robust linear association between the variables under investigation. The user-generated content plays a significant role in influencing the perceptions and attitudes of travellers towards their desired travel destinations. The influence of travel influencers on consumer behaviour is often substantial, as individuals strive to emulate the experiences and activities depicted on Instagram by these influential figures. The analysis of the data revealed a significant correlation between the variables under investigation, as indicated by the correlation table. The results indicate a strong positive correlation between the two variables, suggesting a robust relationship between them. In contemporary society, the influence of online platforms and social media has become increasingly significant in shaping consumer behaviour. One notable aspect of this influence is the impact of user-generated content, such as comments, stories, and posts, on consumer attraction towards certain products or places. By examining the role of user-generated content in consumer decision-making processes, this research seeks to shed light on the underlying mechanisms that drive consumer attraction towards places. In the context of consumer behaviour, user-generated content holds significant sway over consumer perceptions and preferences. This is particularly evident in the realm of online reviews, comments, stories, and posts, where consumers actively seek out and engage with the opinions and experiences of others. The phenomenon of consumer attraction towards places based on user-generated content has been a subject of interest in recent research. The findings of this study indicate that consumers place a greater emphasis on the experiential accounts of others when considering a destination for travel or trip planning. In contemporary society, the act of travelling has emerged as a highly favoured recreational pursuit among individuals. This study has also uncovered that the attitude of individuals, which is influenced by three other factors examined in the research, has a significant impact on consumer decision-making. According to the findings of the regression analysis, it can be observed that the Tour Operator Generated Content (TOGC) exhibits the most significant influence on the explanation of variance in individuals' attitudes towards destination selection. Conversely, User-Generated Content (UGC) demonstrates a moderate impact on the explanation of variance in attitudes towards destination selection. In contrast, electronic Word-of-Mouth (e-WOM) does not appear to have any discernible impact on the explanation of variance in attitudes towards destination selection. The impact of visitors' narratives and social media posts on platforms such as Facebook or Instagram on individuals' attitudes towards travel destinations has been a subject of interest in recent research. These user-generated content (UGC) have the potential to shape individuals' perceptions and considerations regarding visiting a particular location or exploring a new destination. By examining existing literature and empirical evidence, this research seeks to shed light on the extent to which these narratives and posts can impact individuals' travel decisions and shape their attitudes towards specific locations. In the realm of tourism, tour operators have adopted the strategy of promoting destinations or locations through online platforms, with the aim of garnering widespread exposure and influencing potential visitors' decision-making processes. By leveraging the power of the internet, these operators seek to showcase the allure of a particular destination, thereby enticing individuals to consider embarking on a journey to that location. The utilisation of appropriate descriptions, tags, hashtags, photographs, and videos has been found to have a significant impact on increasing both follower count and website visits. By employing these strategies effectively, individuals and businesses can enhance their online presence and attract a larger audience.

## IMPLICATIONS AND FUTURE RESEARCH DIRECTIONS

### Managerial Implications

The utilization of social media by travel companies and destination marketers enables the development of precise and focused marketing strategies. In order to effectively target specific segments of travellers, it is crucial for content creators and advertisers to have a comprehensive understanding of user preferences and behaviours across various platforms. By gaining insights into these factors, they can customize their content and advertisements accordingly. The utilization of hashtags and contests to promote UGC can be highly effective strategy. The utilization of positive user experiences shared on social media platforms by managers can effectively enhance the reputation of their destination or travel service. The collaboration with social media influencers who possess a substantial following in the travel niche can yield advantageous outcomes. Influencers have the ability to effectively promote destinations, offer evaluations, and impact the travel decisions of their followers. The rapid dissemination of negative feedback is a characteristic feature of social media platforms. The responsiveness and proactivity of managers in addressing issues on online platforms are essential for safeguarding the reputation of the destination. The utilization of data analytics tools facilitates the monitoring and analysis consumer sentiment and trends on social media platforms. The availability of this data enables companies to make informed decisions and adjust their strategies in real-time. The utilisation of social media insights can provide valuable guidance in the development of consumer-centric content. In order to optimise their content strategy,

managers have the ability to identify the specific types of content, such as images, videos, and stories, that generate the highest levels of engagement. By recognising these patterns, managers can then tailor their content strategy accordingly.

### Practical Implications

The impact of social media on travel destination preferences is a topic of interest in consumer behaviour research. This study aims to explore the psychological processes involved in decision making when individuals are faced with a wealth of online information. The emergence of this phenomenon prompts inquiries regarding the relevance of media effects theories in the digital era. The prevalence of travel-related information on social media platforms underscores the problem of information overload.

### Future Research Directions

Despite the previously mentioned contributions, it is important to acknowledge that this study has certain limitations that should be considered for future research endeavours. The current range of factors influencing consumer attitudes towards using Instagram for destination selection is quite limited. However, it is important to note that more than three elements may have the potential to impact consumer attitudes in this context. The present study employs a singular social media platform to comprehend the attitudes of consumers and the various factors that exert influence upon them. To comprehensively capture the evolving consumer attitudes, it is imperative to conduct cross-platform comparisons and longitudinal studies in the future. These research methodologies allow for a thorough examination of consumers' changing preferences and opinions over time. Researchers can gain a holistic understanding of consumer attitudes by comparing data across different platforms. Additionally, longitudinal studies enable observing consumer behaviour and attitudes over an extended period, providing valuable insights into the long-term trends and shifts in consumer preferences.

## REFERENCES

- 0013 Ghada.pdf. (n.d.). Retrieved 28 August 2023, from <https://sajth.com/old/jan2013/0013%20Ghada.pdf>
- A Comparative Study of Information Needs of City Travelers in Eur...: Ingenta Connect. (n.d.). Retrieved 26 September 2023, from <https://www.ingentaconnect.com/content/cog/itt/2008/00000010/00000002/art00003>
- Andreea Marin-Pantelescu; Laurentiu Tăchiciu; Sorinel Căpușneanu; Dan Ioan Topor. (2019). Role of Tour Operators and Travel Agencies in Promoting Sustainable Tourism. *Amfiteatru Economic*, 21(52), 654–669.
- Arndt, J. (1967). Role of Product-Related Conversations in the Diffusion of a New Product. *Journal of Marketing Research*, 4(3), 291–295. <https://doi.org/10.1177/002224376700400308>
- Baber, H., Pană, M.-C., & Fanea-Ivanovici, M. (2022). Predicting Romanian tourism e-WOM intentions using value and personality theories. *European Journal of Innovation Management*, ahead-of-print(ahead-of-print). <https://doi.org/10.1108/EJIM-05-2022-0235>
- Book, L. A., Tanford, S., Montgomery, R., & Love, C. (2018). Online Traveler Reviews as Social Influence: Price Is No Longer King. *Journal of Hospitality & Tourism Research*, 42(3), 445–475. <https://doi.org/10.1177/1096348015597029>
- Buhalis, D., & Law, R. (2008). Progress in information technology and tourism management: 20 years on and 10 years after the Internet—The state of eTourism research. *Tourism Management*, 29(4), 609–623. <https://doi.org/10.1016/j.tourman.2008.01.005>
- Buhalis, D., & Licata, M. C. (2002). The future eTourism intermediaries. *Tourism Management*, 23(3), 207–220. [https://doi.org/10.1016/S0261-5177\(01\)00085-1](https://doi.org/10.1016/S0261-5177(01)00085-1)
- Büttner, O. B., & Göritz, A. S. (2008). Perceived trustworthiness of online shops. *Journal of Consumer Behaviour*, 7(1), 35–50. <https://doi.org/10.1002/cb.235>
- Campbell, C., & Farrell, J. R. (2020). More than meets the eye: The functional components underlying influencer marketing. *Business Horizons*, 63(4), 469–479. <https://doi.org/10.1016/j.bushor.2020.03.003>
- Cheung, C. M. K., & Thadani, D. R. (2012). The impact of electronic word-of-mouth communication: A literature analysis and integrative model. *Decision Support Systems*, 54(1), 461–470. <https://doi.org/10.1016/j.dss.2012.06.008>
- Chevalier, J. A., & Mayzlin, D. (2006). The Effect of Word of Mouth on Sales: Online Book Reviews. *Journal of Marketing Research*, 43(3), 345–354. <https://doi.org/10.1509/jmkr.43.3.345>
- Cox, C., Burgess, S., Sellitto, C., & Buultjens, J. (2009). The Role of User-Generated Content in Tourists' Travel Planning Behavior. *Journal of Hospitality Marketing & Management*, 18(8), 743–764. <https://doi.org/10.1080/19368620903235753>
- Filieri, R. (2015). What makes online reviews helpful? A diagnosticity-adoption framework to explain informational and normative influences in e-WOM. *Journal of Business Research*, 68(6), 1261–1270. <https://doi.org/10.1016/j.jbusres.2014.11.006>
- Filieri, R., Alguezaui, S., & McLeay, F. (2015). Why do travelers trust TripAdvisor? Antecedents of trust towards consumer-generated media and its influence on recommendation adoption and word of mouth. *Tourism Management*, 51, 174–185. <https://doi.org/10.1016/j.tourman.2015.05.007>
- Fotis, J., Buhalis, D., & Rossides, N. (2011). Social Media Impact on Holiday Travel Planning: The Case of the Russian and the FSU Markets. *International Journal of Online Marketing (IJOM)*, 1(4), 1–19. <https://doi.org/10.4018/ijom.2011100101>
- Gartner, W. C. (1989). Tourism Image: Attribute Measurement of State Tourism Products Using Multidimensional Scaling Techniques. *Journal of Travel Research*, 28(2), 16–20. <https://doi.org/10.1177/004728758902800205>

- Gholamhosseinzadeh, M. S., Chapuis, J.-M., & Lehu, J.-M. (2023). Tourism netnography: How travel bloggers influence destination image. *Tourism Recreation Research*, 48(2), 188–204. <https://doi.org/10.1080/02508281.2021.1911274>
- Gilly, M. C., Graham, J. L., Wolfinbarger, M. F., & Yale, L. J. (1998). A Dyadic Study of Interpersonal Information Search. *Journal of the Academy of Marketing Science*, 26(2), 83–100. <https://doi.org/10.1177/0092070398262001>
- Hua, L. Y., Ramayah, T., Ping, T. A., & (Jacky), C. J.-H. (2017). Social Media as a Tool to Help Select Tourism Destinations: The Case of Malaysia. *Information Systems Management*, 34(3), 265–279. <https://doi.org/10.1080/10580530.2017.1330004>
- Instagram advertising and marketing. (n.d.). Statista. Retrieved 26 September 2023, from <https://www.statista.com/study/62092/instagram-marketing-and-advertising/>
- Kang, J.-W., & Namkung, Y. (2016). Restaurant Information Sharing on Social Networking Sites: Do Network Externalities Matter? *Journal of Hospitality & Tourism Research*, 40(6), 739–763. <https://doi.org/10.1177/1096348015619413>
- Kaplan, A. M., & Haenlein, M. (2010). Users of the world, unite! The challenges and opportunities of Social Media. *Business Horizons*, 53(1), 59–68. <https://doi.org/10.1016/j.bushor.2009.09.003>
- Khan, M. M., Siddique, M., Yasir, M., Qureshi, M. I., Khan, N., & Safdar, M. Z. (2022). The Significance of Digital Marketing in Shaping Ecotourism Behaviour through Destination Image. *Sustainability*, 14(12), Article 12. <https://doi.org/10.3390/su14127395>
- Kilipiri, E., Papaioannou, E., & Kotzaivazoglou, I. (2023). Social Media and Influencer Marketing for Promoting Sustainable Tourism Destinations: The Instagram Case. *Sustainability*, 15(8), Article 8. <https://doi.org/10.3390/su15086374>
- Kim, S.-E., Lee, K. Y., Shin, S. I., & Yang, S.-B. (2017). Effects of tourism information quality in social media on destination image formation: The case of Sina Weibo. *Information & Management*, 54(6), 687–702. <https://doi.org/10.1016/j.im.2017.02.009>
- Lee, S., Song, H., Lee, C.-K., & Petrick, J. F. (2018). An Integrated Model of Pop Culture Fans' Travel Decision-Making Processes. *Journal of Travel Research*, 57(5), 687–701. <https://doi.org/10.1177/0047287517708619>
- López, M., & Sicilia, M. (2014). Determinants of E-WOM Influence: The Role of Consumers' Internet Experience. *Journal of Theoretical and Applied Electronic Commerce Research*, 9(1), Article 1. <https://doi.org/10.4067/S0718-18762014000100004>
- Marder, B., Archer-Brown, C., Colliander, J., & Lambert, A. (2019). Vacation Posts on Facebook: A Model for Incidental Vicarious Travel Consumption. *Journal of Travel Research*, 58(6), 1014–1033. <https://doi.org/10.1177/0047287518786465>
- Marine-Roig, E., & Ferrer-Rosell, B. (2018). Measuring the gap between projected and perceived destination images of Catalonia using compositional analysis. *Tourism Management*, 68, 236–249. <https://doi.org/10.1016/j.tourman.2018.03.020>
- Mayo, E. J., & Jarvis, L. P. (1981). The psychology of leisure travel. Effective marketing and selling of travel services. *The Psychology of Leisure Travel. Effective Marketing and Selling of Travel Services*. <https://www.cabdirect.org/cabdirect/abstract/19821887439>
- McCabe, S., Li, C. (Spring), & Chen, Z. (2016). Time for a Radical Reappraisal of Tourist Decision Making? Toward a New Conceptual Model. *Journal of Travel Research*, 55(1), 3–15. <https://doi.org/10.1177/0047287515592973>
- Mehmood, S., Liang, C., & Gu, D. (2018). Heritage Image and Attitudes toward a Heritage Site: Do They Really Mediate the Relationship between User-Generated Content and Travel Intentions toward a Heritage Site? *Sustainability*, 10(12), Article 12. <https://doi.org/10.3390/su10124403>
- Nayak, N., Polus, R., & Piramanayagam, S. (2023). What can online reviews reveal about Tourism Destination Image? A netnographic approach to a pilgrim destination in India. *Tourism Recreation Research*, 0(0), 1–17. <https://doi.org/10.1080/02508281.2022.2160921>
- Nezakati, H., Amidi, A., Jusoh, Y. Y., Moghadas, S., Aziz, Y. A., & Sohrabinezhadtalemi, R. (2015). Review of Social Media Potential on Knowledge Sharing and Collaboration in Tourism Industry. *Procedia - Social and Behavioral Sciences*, 172, 120–125. <https://doi.org/10.1016/j.sbspro.2015.01.344>
- Pudliner, B. A. (2007). Alternative Literature and Tourist Experience: Travel and Tourist Weblogs. *Journal of Tourism and Cultural Change*, 5(1), 46–59. <https://doi.org/10.2167/jtcc051.0>
- Senders, A., Govers, R., & Neuts, B. (2013). Social Media Affecting Tour Operators' Customer Loyalty. *Journal of Travel & Tourism Marketing*, 30(1–2), 41–57. <https://doi.org/10.1080/10548408.2013.750993>
- Sheldon, P. J. (1997). Tourism information technology. *Tourism Information Technology*. <https://www.cabdirect.org/cabdirect/abstract/19971811223>
- Simms, A. (2012). Online user-generated content for travel planning—Different for different kinds of trips? *Faculty of Business - Papers (Archive)*, 76–85.
- Stepchenkova, S., & Mills, J. E. (2010). Destination Image: A Meta-Analysis of 2000–2007 Research. *Journal of Hospitality Marketing & Management*, 19(6), 575–609. <https://doi.org/10.1080/19368623.2010.493071>
- Sultan, M. T., Sharmin, F., Badulescu, A., Gavrilut, D., & Xue, K. (2021). Social Media-Based Content towards Image Formation: A New Approach to the Selection of Sustainable Destinations. *Sustainability*, 13(8), Article 8. <https://doi.org/10.3390/su13084241>
- Tham, A., Croy, G., & Mair, J. (2013). Social Media in Destination Choice: Distinctive Electronic Word-of-Mouth Dimensions. *Journal of Travel & Tourism Marketing*, 30(1–2), 144–155. <https://doi.org/10.1080/10548408.2013.751272>
- Tham, A., Mair, J., & Croy, G. (2020). Social media influence on tourists' destination choice: Importance of context. *Tourism Recreation Research*, 45(2), 161–175. <https://doi.org/10.1080/02508281.2019.1700655>

- Tsiakali, K. (2018). User-generated-content versus marketing-generated-content: Personality and content influence on traveler's behavior. *Journal of Hospitality Marketing & Management*, 27(8), 946–972. <https://doi.org/10.1080/19368623.2018.1477643>
- Um, S., & Crompton, J. L. (1990). Attitude determinants in tourism destination choice. *Annals of Tourism Research*, 17(3), 432–448. [https://doi.org/10.1016/0160-7383\(90\)90008-F](https://doi.org/10.1016/0160-7383(90)90008-F)
- Werthner, H., & Klein, S. (1999). Information technology and tourism: A challenging relationship. *Information Technology and Tourism: A Challenging Relationship*. <https://www.cabdirect.org/cabdirect/abstract/19991808172>
- Xiang, Z., & Gretzel, U. (2010). Role of social media in online travel information search. *Tourism Management*, 31(2), 179–188. <https://doi.org/10.1016/j.tourman.2009.02.016>
- Xiang, Z., Wöber, K., & Fesenmaier, D. R. (2008). Representation of the Online Tourism Domain in Search Engines. *Journal of Travel Research*, 47(2), 137–150. <https://doi.org/10.1177/0047287508321193>
- Yoo, K.-H., & Gretzel, U. (2011). Influence of personality on travel-related consumer-generated media creation. *Computers in Human Behavior*, 27(2), 609–621. <https://doi.org/10.1016/j.chb.2010.05.002>
- Yoo, K.-H., Lee, Y., Gretzel, U., & Fesenmaier, D. R. (2009). Trust in Travel-related Consumer Generated Media. In W. Höpken, U. Gretzel, & R. Law (Eds.), *Information and Communication Technologies in Tourism 2009* (pp. 49–59). Springer. [https://doi.org/10.1007/978-3-211-93971-0\\_5](https://doi.org/10.1007/978-3-211-93971-0_5)
- Zeng, B., & Gerritsen, R. (2014). What do we know about social media in tourism? A review. *Tourism Management Perspectives*, 10, 27–36. <https://doi.org/10.1016/j.tmp.2014.01.001>
- Zhang, K., Chen, D., & Li, C. (2020). How are Tourists Different? - Reading Geo-tagged Photos through a Deep Learning Model. *Journal of Quality Assurance in Hospitality & Tourism*, 21(2), 234–243. <https://doi.org/10.1080/1528008X.2019.1653243>

## Interactive Interface Design of Aging Smart Home Products Based on Perception Ability Evaluation

Shengzan Yan<sup>1,4,\*</sup>  
Yi-nan Li<sup>2</sup>  
Yiru Chen<sup>3</sup>

\*Corresponding author

<sup>1</sup> Associate professor, Nanjing Institute of Technology, Nanjing, China, shengzanyan@njit.edu.cn

<sup>2</sup> Professor Southeast University, Nanjing, China, ynli19@163.com

<sup>3</sup> Student, Nanjing Institute of Technology, Nanjing, China, 3460008215@qq.com

<sup>4</sup> Visiting scholar, Southeast University, Nanjing, China, shengzanyan@njit.edu.cn

### ABSTRACT

Facing the population aging and product intelligence, comprehensively, systematically and accurately grasp the perception ability of the elderly, build a rule system for the design of smart home products suitable for the elderly, establish a practical basis for the design of smart home products for the elderly, and improve the quality of life of the elderly at home. The perception ability of the elderly is classified and summarized, and a questionnaire on the use status of smart home products for the elderly is compiled to investigate 30 elderly people aged 65-80. The survey data were analyzed by statistical methods to form user images and user use maps, as well as an evaluation system for the perception ability of the elderly. Visual ability, auditory ability, tactile ability, cognitive ability and psychological state are the main factors affecting the satisfaction evaluation of the interactive interface of smart home products for the elderly. According to the evaluation index system of perception ability, combined with the design practice cases, three interactive interface design methods of smart home products for the elderly, such as multi-sensory cognitive design, rough operation interaction design and emotional care design, are explored and summarized. The analysis of the design case verifies the effectiveness of the design method, and also shows the importance of user participation in the design process, as well as the role of simplicity, multi-sensory, rough operation and wizard in improving the satisfaction of elderly in using smart home products.

*Keywords:* smart home products, interactive interface, perception, evaluation system, design method.

### INTRODUCTION

#### Background

With the background of an aging society, the elderly population is growing, and they frequently encounter a myriad of challenges including shifts in health status and diminishing self-care abilities in their daily lives. As an innovative technical solution, smart home products provide practical help for the elderly (Majumder *et al.*, 2017). These products combine the Internet of Things (IoT), artificial intelligence (AI) and sensing technology to automatically monitor and adapt to the needs of the elderly and create a safer, more convenient and comfortable living environment for them (Zhang *et al.*, 2020).

The role of smart home products in the lives of the elderly is reflected in many aspects (Maswadi *et al.*, 2020). First of all, smart home products can real-time monitor the living conditions of the elderly through remote monitoring and alarm systems, such as sleep quality and activity, so as to help family members or nursing staff keep abreast of the situation of the elderly. Secondly, smart home products can provide medical support, such as regular medication reminders, health data tracking, etc., to help the elderly better manage health problems (Sooraj *et al.*, 2020). In addition, smart home products can also optimize the living environment, such as intelligent lighting and temperature control systems, automatically adapt to the needs of the elderly and provide a more comfortable living experience.

In an aging society, social activities of older people may also be limited, and smart home products can help them maintain contact with family and friends through functions such as video calls and social media connections (Jo *et al.*, 2021). In addition, smart home products can also provide emergency help functions, and the elderly can call for help in time when they encounter accidents or emergencies.

In general, smart home products play an active role in the lives of the elderly, creating a safer, more convenient and more comfortable living environment for them. By integrating advanced technologies, these products are expected to help older people maintain independence, reduce the burden on their families, and improve their quality of life. However, in order to achieve the best results, the design of smart home products requires an in-depth understanding of the needs and perceptions of the elderly to ensure that the products can truly meet their needs.



**Challenge**

In the process of using smart home products for the elderly, interactive interface design is a key challenge. The elderly may face multiple challenges, including decreased perception, unfamiliarity with technology, and increased cognitive burden (Coşar et al., 2020; Jo et al., 2021; Pal et al., 2019). These factors emphasize the need to consider the special needs and perception of the elderly when designing the interactive interface of smart home products, as shown in Figure 1.

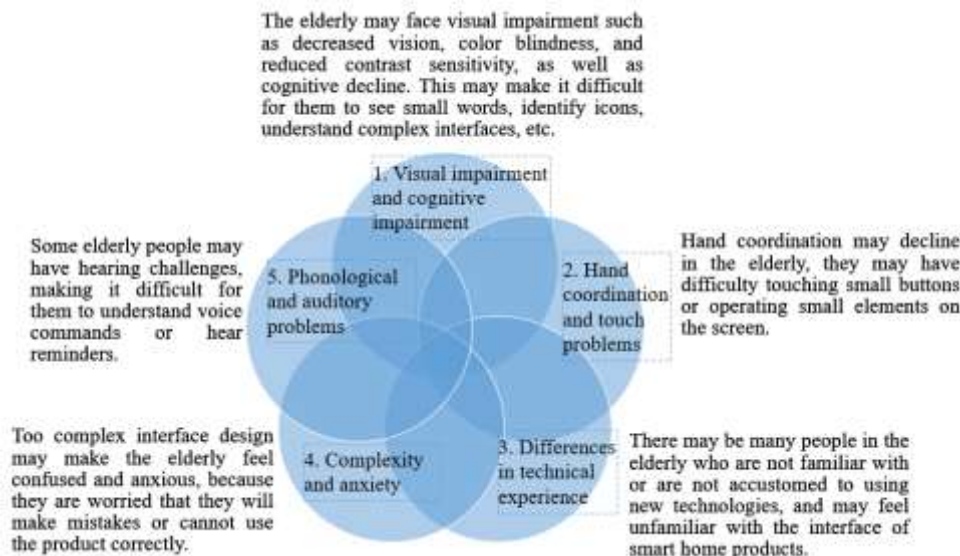

Source: This study.

Figure 1: Perception and special needs of the elderly.

In tackling these challenges, a pivotal factor lies in comprehending the requirements, routines, and technological receptiveness of the elderly population. The interactive interface design of age-friendly smart home products should prioritize user-centered principles, ensuring that the products can seamlessly meet the needs of the elderly population (Zhou & Wang, 2023). However, there are still certain issues with the interactive interface design of age-friendly smart home products available in the market (Zhou et al., 2022). For instance, issues such as excessively complex interface operations, small fonts, and inappropriate color combinations significantly hamper the usability and user experience among the elderly population. These concerns even pose potential threats to the health and safety of elderly individuals.

**RELATED WORK**

**Principles of Age-Friendly Design**

The principles of age-friendly design refer to considering the unique needs and abilities of older individuals in the design of products, services, and environments, with the aim of creating interfaces and experiences better suited to their usage (Iancu, 2020). These principles are intended to ensure that older adults can utilize a variety of products with ease and safety, thereby enhancing their quality of life and independence. Common principles of age-friendly design (Fan et al., 2023; Zhu et al., 2022) are illustrated in Figure 2.

Principles of Elderly Friendly Design	Readability and identifiability	• Ensure that the text, icons and tags on the interface are of sufficient size and clarity so that the elderly can easily identify and read.
	high-contrast	• Use a high-contrast color combination to ensure the discrimination between interface elements and help the elderly better distinguish the content.
	Simplify the interface	• Avoid too many complex options and functions, keep the interface simple and clear, and reduce the cognitive burden.
	consistency	• Maintain the consistency of interface elements, such as the location, color and style of buttons, to reduce confusion of older people.
	Large operating area	• Increasing the size of buttons and interactive elements makes it easier for the elderly to click and operate and reduce false touches.
	voice interaction	• It provides voice recognition and voice guidance functions, so that the elderly can operate and obtain information through voice.
	tactile feedback	• Provide tactile feedback for interface operation, so that the elderly know whether their operation is successful.
	Easy-to-access help	• Provide easy access to help and support, so that the elderly can get timely guidance when they encounter problems.
	Emergency help function	• Integrate emergency help buttons or functions in the product so that the elderly can quickly get help in an emergency.
Adaptability settings	• It allows the elderly to adjust the interface settings according to their preferences, such as text size, color, etc.	

Source: This study.

Figure 2: Common elderly-friendly design principles.

The objective of age-friendly design principles is to develop products that align with the capabilities and needs of older individuals, enabling them to participate more effectively in social life and relish the convenience offered by technology. By adhering to these principles, designers can craft products that are notably more inclusive and user-friendly.

### Age-Friendly Interface Design

Age-friendly interface design involves integrating human-computer interaction interface design with the specific needs and perceptual capabilities of older individuals. Its goal is to make product interfaces better suited for elderly use. Research in this domain primarily focuses on how to enhance usability and comprehensibility of interfaces, tailored to meet the special requirements of older adults, thus elevating their user experience. For instance, researchers have proposed a series of age-friendly interface design principles, including readability, ease of operation, streamlined interfaces, and larger buttons (Ruzic et al., 2016; Ruzic & Sanford, 2017). They have also developed methods to assess the difficulty and satisfaction of older individuals while using interfaces, such as usability testing and focus group discussions (Ruzic et al., 2017; Granata et al., 2013). Additionally, some researchers focus on changes in the perceptual abilities of older adults, particularly in terms of vision and hearing issues. They explore how to accommodate older adults' visual needs, such as adjusting font sizes and color contrasts (De Barros et al., 2014). Simultaneously, they investigate the integration of audio guidance, voice interactions, and other features in interfaces to cater to hearing impairments (Fischer et al., 2019; Mitzner et al., 2010). Certain scholars are also dedicated to reducing cognitive load for older adults when using interfaces (Khawaja et al., 2014). They delve into simplifying interface layouts, providing clear labels and instructions, as well as offering easily understandable operational sequences. Research on age-friendly interface design also addresses how to provide training and support specifically tailored to older individuals, helping them become familiar with and adept at new technologies (Miraz et al., 2021). This could encompass user guides, video tutorials, and more. Moreover, researchers have applied accessibility testing and usability testing to age-friendly interface design to ensure the interface's user-friendliness for older adults (Coşar et al., 2020). These tests aid in identifying issues within the interface and guiding improvements. These studies aim to enhance the comfort and satisfaction of older adults when using technological products and services, assisting them in better adapting to the digital society.

### Perceptual Ability Evaluation Method

The application of the design method based on perceptual ability evaluation in the elderly user group aims to optimize the design of products and interfaces by understanding the perceptual characteristics and needs of the elderly, so as to improve their user experience and the readability, comprehensibility and ease of use of the interface. This method emphasizes the perception of the elderly as a core design consideration, so as to create a product more suitable for their use.

The design based on the perceptual ability evaluation method is mainly divided into seven steps. The first step is the analysis of perceptual ability; the second step is the target user definition; the third step is the formulation of design principles; the fourth step is interactive interface design; the fifth step is to recruit user tests; the sixth step is perception ability evaluation; the seventh step is continuous optimization and improvement. This also corresponds to the design process and steps of the aging smart home interactive interface based on the perception ability evaluation method, as shown in Figure 3.

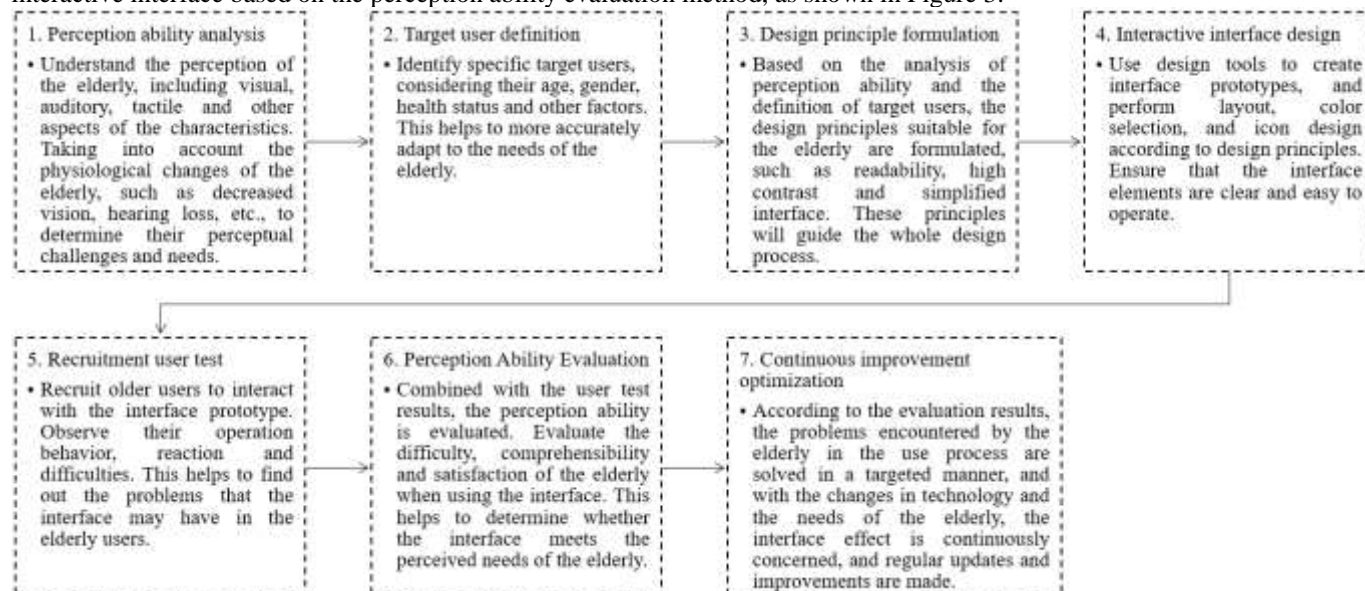

Source: This study.

Figure 3: Design process and steps.

This design method based on perceptual ability evaluation can help designers better understand the needs of the elderly and avoid ignoring their special circumstances in design. Through in-depth study of perception ability and design optimization based on the actual experience of the elderly, products and interfaces that are more suitable for the elderly can be created. In recent years, some researchers have conducted design effectiveness evaluation studies for the elderly (Li & Luximon, 2023). Focusing on improving the user experience, they recruited participants to participate in experiments to analyze the influencing factors of the



elderly's acceptance of intelligent virtual assistants (Liu et al., 2023), usability testing of mobile interface navigation, etc. (Li & Luximon, 2020).

The research on age-friendly interface design for smart home products will be conducted in three phases: preliminary, middle, and final. In the preliminary phase, we will initiate the research with user studies, combining methods like surveys and interviews, to deeply understand the perceptual abilities of older individuals. This will help us identify the challenges and needs they face in terms of perception, allowing us to accurately define the target user group. In the middle phase, based on the analysis of perceptual abilities and the definition of target users, we will formulate age-friendly design principles and employ design tools to complete the prototype design of the interactive interface. In the final phase, we will recruit older users for interactive testing to obtain feedback on perceptual capabilities. Subsequently, we will optimize the design further based on these evaluation results.

### SMART HOME PRODUCT INTERFACE DESIGN PRINCIPLES

The core principles of smart home product interface design revolve around ensuring user-friendliness and usability, while also thoroughly considering the specific needs and perceptual capabilities of the user demographic. These principles can aid designers in creating more intuitive and user-desired smart home product interface designs, ultimately enhancing user experience and satisfaction. In short, the design of the interactive interface of smart home products should be user-oriented, follow the principle of aging, and emphasize the design concept of ease of use, accessibility and humanization.

The fundamental principles and methods of interaction design are indispensable parts in the design of smart home products. Concerning the fundamental principles of interaction design, firstly, interface consistency is crucial as it enables users to maintain familiarity and coherence across different scenarios (Punchoojit & Hongwarittorn, 2017). Secondly, usability and accessibility are essential factors that must be considered when designing interactive interfaces for the elderly (Sauer et al., 2020). By considering user habits and the characteristics of smart home products, designers can enhance the user experience of the elderly by improving usability and accessibility. Additionally, scalability is another crucial design principle, which can ensure that the product has good sustainability and future development potential (Ni et al., 2022). Regarding interaction design methods, user research, task flow analysis, information architecture design and other methods are commonly employed approaches. These methods can assist designers in gaining in-depth insights into user needs and delivering an improved user experience.

In today's digital era, the importance of interface design has become increasingly prominent, particularly in terms of user experience and usability. Within the domain of smart home product interactive interface design, usability, readability, and clarity stand as crucial elements. When it comes to designing interactive interfaces of smart home products for elderly users, the principles can be primarily emphasized in three aspects. First, how to improve usability through a clear and concise interface layout; second, how to select appropriate icons and labels to enhance recognizability; third, how to augment readability via high-contrast colors and larger fonts.

#### Simple and Clear Interface Layout

A simple and clear interface layout is one of the important means to improve usability. A well-designed interface layout can make it easier for users to comprehend and interact with the interface, thus reducing confusion and erroneous actions. Designers can create a clear and concise interface layout through the following design steps and considerations, as illustrated in Figure 4.

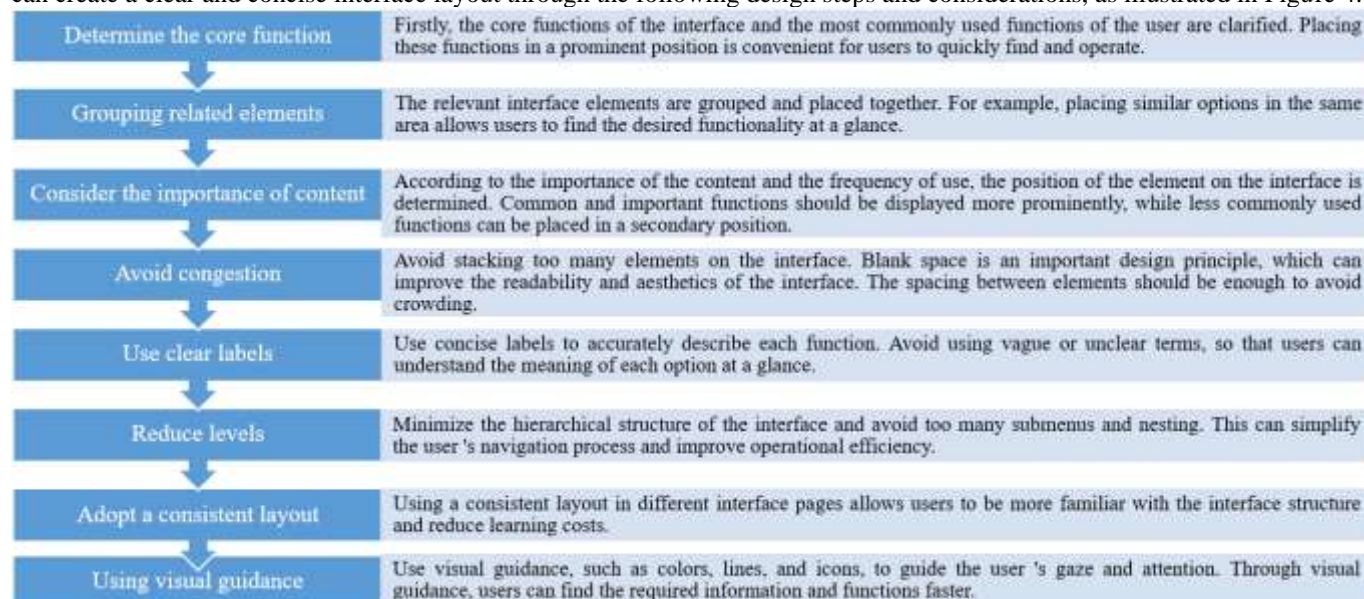

Source: This study.

Figure 4: The design steps and precautions of the concise and clear interface layout.

A simple and clear interface layout can improve user satisfaction and efficiency. Throughout the design process, always take the user as the center and focusing on their needs and habits, so as to create interfaces that are user-friendly and aligned with user expectations.

### **Clear Icons and Labels**

Choosing appropriate icons and labels is a crucial aspect of designing interface recognizability, as it significantly impacts users' comprehension of interface functions and options. This section will discuss how to select suitable icons and labels to enhance the recognizability of the interface.

#### ***Icon selection and design***

Choosing appropriate icons is one of the core tasks in interface design. Well-chosen icons can visually convey functions, aiding users in swiftly comprehending and navigating the interface. When selecting and designing icons, several essential principles should be followed. Firstly, universality and intuitiveness: select widely recognized universal icons, such as search, settings, and favorites. These icons convey the same meanings across diverse languages and cultural backgrounds, helping eliminate communication barriers. Secondly, avoid ambiguity: choose icons that are less prone to ambiguity, ensuring their meanings remain clear in various contexts. The meaning of icons should not conflict with other functionalities to prevent user confusion. Additionally, simplicity and recognizability: icons should maintain simplicity and avoid excessive intricate details. Even in small sizes, icons should remain distinguishable. Clear outlines and distinct colors contribute to enhancing icon recognizability.

#### ***Selection and Expression of Labels***

Labels, as textual interface elements, provide more detailed information and aid users in accurately understanding functions. When choosing and expressing labels, several factors need to be considered. Firstly, clarity and conciseness: labels should clearly describe functions using concise and accurate vocabulary. Labels should avoid ambiguity or vagueness to prevent user confusion. Secondly, alignment with user expectations: labels should align with user expectations, employing vocabulary and expressions familiar to users. This helps users swiftly comprehend and recognize functions. Additionally, language and cultural adaptation: if the interface is to be used in different regions, ensure the selected labels are appropriate in various language and cultural contexts. Avoid using region-specific or difficult-to-translate terms.

#### ***Color scheme and consistency***

The color scheme plays a crucial role in the recognizability of icons and labels. Colors and shapes can assist users in quickly comprehending functions and meanings. During the design process, color consistency needs to be considered: the colors of icons and labels should align with the overall interface color scheme to maintain visual harmony. Additionally, colors can be used to emphasize essential functions or information. Furthermore, the significance of shapes should also be taken into account: the shape of an icon can convey a specific meaning, such as a lock shape indicating security or an arrow shape signifying navigation. The selection of shapes should correspond to the associated functions.

#### ***User testing and feedback***

The ultimate goal of the design is to provide interfaces that align with user needs. During the design phase, conducting user testing to gather feedback from real users is essential. Through user testing, we can ascertain whether users can accurately comprehend and recognize the meanings of icons and labels. User feedback can guide us in adjusting icons and labels to make them more distinguishable and easily understandable.

In conclusion, selecting appropriate icons and labels to enhance interface recognizability requires a comprehensive consideration of factors such as universality, intuitiveness, clarity, and consistency. Through thoughtful design and user testing, we can create user-friendly interfaces, enhance user experience, and achieve higher quality interactions.

### **High Contrast and Large Fonts**

The role of high contrast colors and large fonts in interface design is to enhance readability and accessibility, particularly for users with visual impairments or specific needs. The following will separately discuss the roles of high contrast colors and large fonts in improving readability.

#### ***High contrast colors***

High contrast colors refer to increasing the color difference between different elements, making them easier to distinguish. This is particularly crucial for users with visual impairments, color blindness, and elderly individuals. The role of high contrast colors in improving readability is shown in Figure 5.

#### ***Large fonts***

Using large fonts in interface design similarly improves readability and accessibility, especially for users with visual impairments, the elderly, or users on mobile devices. The role of large fonts in improving readability is illustrated in Figure 6.

In summary, the roles of high contrast colors and large fonts in interface design are to enhance readability and accessibility, ensuring that users can easily comprehend and interact with applications or websites. These design principles contribute to creating interfaces that are more user-friendly and easy-to-use, catering to the needs of diverse user groups.

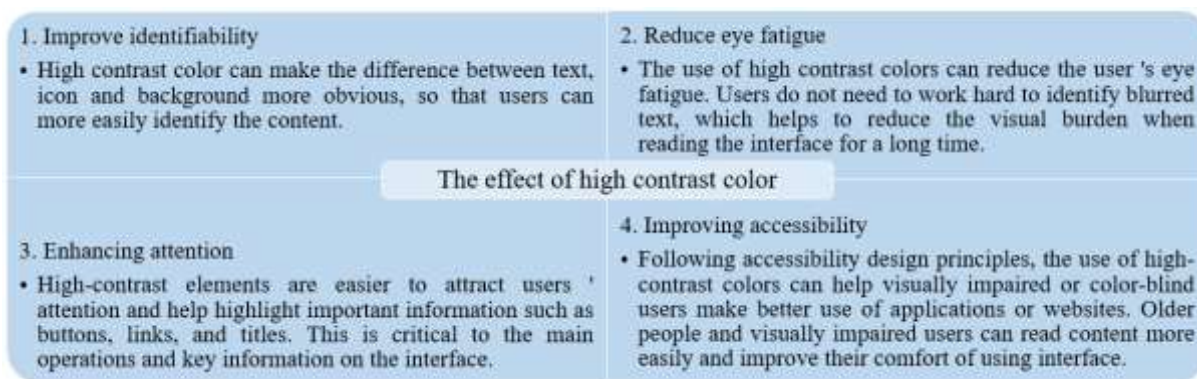

Source: This study.

Figure 5: The Role of High Contrast Colors in Improving Readability.

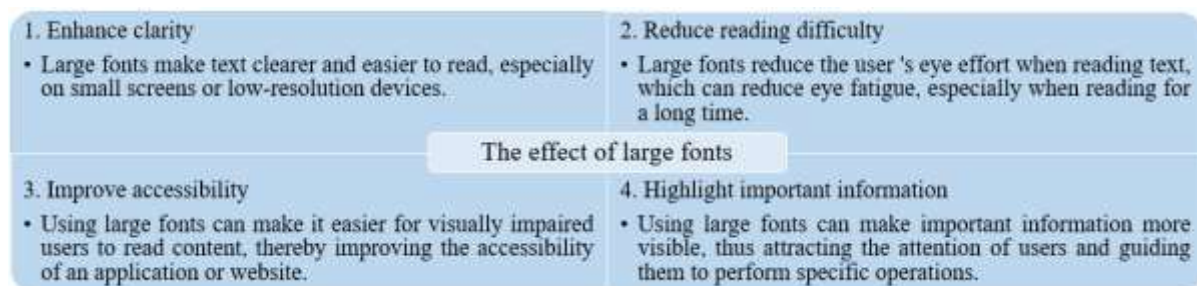

Source: This study.

Figure 6: The Role of Large Fonts in Improving Readability.

**DESIGN METHOD BASED ON PERCEPTUAL ABILITY EVALUATION**

**Analysis on the Characteristics of Perception Ability**

The perceptual abilities of the elderly may exhibit certain characteristics and changes at the physiological, cognitive, and psychological levels. The physiological characteristics and cognitive abilities of the elderly are critically important for the design of age-friendly smart home products. Cognition involves a series of responses by which individuals perceive the objective world, primarily including five important processes of sensation, perception, memory, imagination and thinking. Through cognitive responses to stimuli, individuals process information and achieve self-regulation. With the increase of age, various physiological functions of the elderly start to decline, and their self-regulatory capacities gradually weaken. This is manifested in the following aspects: Firstly, the visual, auditory, tactile, and motor abilities of the elderly are affected to varying degrees. Design considerations should address these physiological characteristics by incorporating interfaces and control methods that cater to them. For instance, enlarging fonts, adjusting colors and brightness, and utilizing voice controls. Additionally, the cognitive abilities of the elderly are also impacted. Learning, memory, reaction time, and thinking abilities gradually decrease. Therefore, in interaction design, it's necessary to simplify operational procedures, reduce redundant information, use easy-to-understand icons and symbols, and lower barriers to usage and error rates.

Table 1: Analysis of the characteristics of the elderly perception ability and design countermeasures

Perception type	Characteristics analysis	Concrete problems	Countermeasures for aging design
Visual perception	Vision drop	Unable to see small words, low contrast colors, or details.	1.Large font; 2.High contrast color; 3.Reducing detail; 4.Replacing words with pictures
	Reduced light adaptability	When switching from a bright to a dark environment, it takes longer to adapt.	light compensation
Auditory perception ability	Hearing drop	Most of the elderly will have a certain decline in hearing, especially for high-frequency sound sensitivity weakened. This may affect speech comprehension and communication with people.	1.Multimodal interaction form 2.In voice interaction mode, the volume and speed can be adjusted
Tactile perception ability	Reduced tactile sensitivity	The ability of elderly to perceive subtle tactile differences is weakened.	1.Obvious concave-convex touch 2.'Tactile +' interactive form
Cognitive abilities	Processing speed slows down	The elderly need longer time to understand and make decisions.	Extend the waiting time
	Memory decline	It is more difficult for the elderly to remember complex instructions, passwords, etc.	1.Reduce the interface level 2.Guidance icon

Exercise capacity	Decreased fine motor ability	Some operations that require accurate control of finger and wrist movements become more difficult.	1.increase the size of the icon 2.Increase the space between icons
Emotional and psychological	Decreased self-confidence	Due to changes in perception and motor skills, older people may feel less confident, especially when interacting with new technologies and new environments.	1.Natural interaction 2.Integration of old and new technologies
	Emotional reaction changes	Older people are more likely to be affected by emotions, which may affect their perception and experience of interfaces and applications.	1.Simulate the voice of relatives 2.Relaxing background music

Source: This study.

Taking a comprehensive view, the perceptual abilities of the elderly may undergo varying degrees of change and decline across multiple aspects. These changes need to be taken into consideration when designing age-friendly interfaces, in order to create interfaces that are easier for the elderly to comprehend and operate, thereby enhancing usability and user experience.

**Perceptual Ability Evaluation Indicators**

The indicators for evaluating the perceptual abilities of the elderly individuals cover visual, auditory, tactile and cognitive capabilities. These indicators assist designers in comprehending the elderly users' perceptual abilities across various domains and insightfully adapting to their needs. The evaluation of elderly individuals' perceptual abilities in a home environment primarily includes assessing the accessibility, ease of access, and completeness of perceptual abilities themselves, as well as subjective experiential evaluation after perceptual tasks are completed. The survey questionnaire consists of two parts: an evaluation of the elderly's perceived completion process of perceptual actions and a subjective experiential assessment by the participants after completing the perceptual tasks. Upon obtaining the corresponding data, through factor analysis and regression analysis, the relationship between objective perceptual abilities and subjective evaluations is analyzed, leading to the derivation of a perceptual ability evaluation framework for elderly individuals concerning smart home product interaction interfaces, as illustrated in Figure 7. By comprehensively utilizing these evaluation indicators, a holistic understanding of the elderly's perceptual abilities can be achieved, enabling designers to better grasp their needs and consequently develop interfaces and products that align with the characteristics of elderly users.

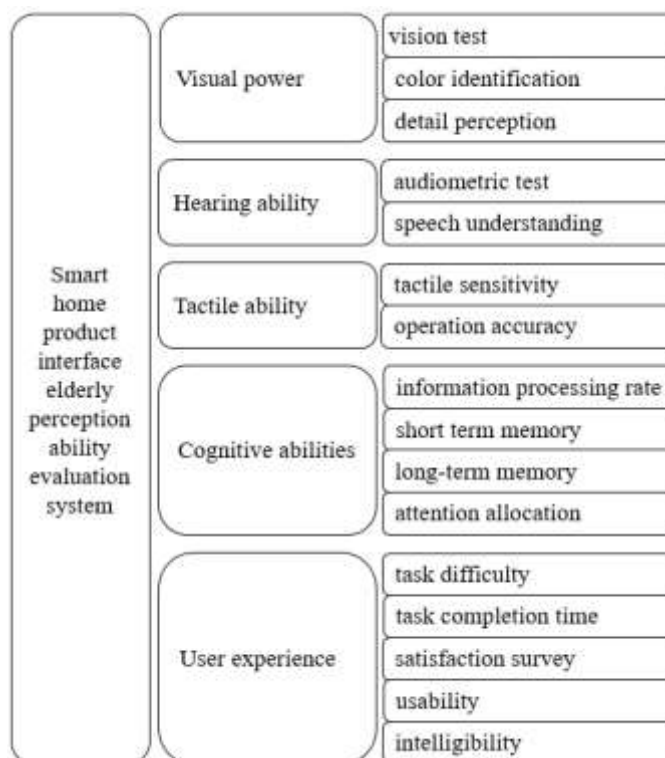

Source: This study.

Figure 7: Perceptual ability evaluation framework for elderly individuals.

**Discussion on Design Methods**

Based on the evaluation indicators of elderly users' perceptual abilities in the context of smart home product interfaces, and considering the current state of their perceptual abilities, this article derives three design methodologies for creating interfaces that cater to the perceptual abilities of the elderly. These methodologies are developed by integrating the evaluation indicators of perceptual abilities, aligning with interface interaction design principles, and drawing insights from case studies of smart home product designs for the elderly. Through analysis and synthesis, these design methodologies are formulated to integrate

perceptual ability evaluation indicators into the design process and create interfaces that are adapted to the perceptual abilities of the elderly.

### ***Multi-sensory cognitive design method***

The cognitive process involves information acquisition and recognition, as well as information processing and judgment. In product design for the elderly, it's essential to expand the cognitive threshold of the product, utilizing a comprehensive combination of sensory perception like auditory, visual, and tactile, promoting their mutual complementarity, and reducing the demands on declining abilities like memory. Based on the product usage scenarios, the optimal design of the cognitive path is realized through multi-sensory recognition, continuous guidance, effective assistance and other design methods to overcome the problems caused by the decline of cognitive ability.

Audio and visual aids can help users better understand and operate the interface by providing audio tips, voice interactions, and visual aids. Tactile and auditory aids can improve the accuracy of interface operations by adding feedback such as vibration or clicking sounds, and avoid users being frustrated by operational errors. Visual and tactile assistance can help users confirm the success of the operation through visual changes such as button bumps and color changes. In summary, design strategies that include high-contrast color schemes, large text fonts for visual design, adjustable audio options, clear and easy to understand voice prompts, user-friendly buttons and interface elements, and tactile feedback such as vibration or alert sounds can be applied from visual, auditory, and tactile perspectives. These strategies can expand the product's cognitive threshold, reduce the cognitive demands on users, and improve the usability of smart home product interfaces.

### ***Rough operation interaction design method***

Fine motor skills primarily involve the hands, and older adults often face difficulties with fine motor tasks due to factors like reduced vision, grip strength, and finger dexterity. In design, these challenges should be avoided whenever possible. In cases where fine motor tasks are unavoidable in product design, they can be addressed through auxiliary product design, simplifying fine motor actions into gross motor actions, and seeking alternative solutions. Simplifying fine motor actions into gross motor actions is the most commonly used and effective method in the design of products for older adults. In interface design, this method requires a deep understanding of the interaction actions themselves and multiple alternative solutions to achieve the goal of interaction.

The gross motor interaction design method focuses on the interface design for older adults and other users with limited operation abilities. It emphasizes simplifying operational steps, reducing cognitive burden, and improving usability to make digital products and interfaces more user-friendly for those who may have challenges related to vision, hearing, touch, and cognition. For example, on mobile devices or computers, providing a 'magnifier' mode for older users to enlarge content on the screen, making text, icons, and interface elements larger and clearer. Alternatively, when older users are using an application or device for the first time, providing a simplified setup wizard to guide them through basic configuration steps based on their preferences, such as language, font size, and notifications. By employing the gross motor interaction design method to optimize interface design according to the perceptual capabilities of older adults, digital products and applications become more accessible to them.

### ***Emotional care design method***

The Emotional Care Design method aims to achieve a comprehensive user experience and emphasizes the emotional connection between users and products. In interface design for the elderly, a comprehensive experience includes not only users' operational and cognitive abilities but also emotional experiences, so as to create a warmer, more welcoming, and enjoyable user experience. The goal of this method is to create products that establish an emotional connection with users, making them feel understood, respected, and cared for. The Emotional Care Design method can be applied in various fields, such as smart home products, mobile applications, medical devices, and especially when targeting older adults and users with special needs. It can improve user experiences, increase user satisfaction, and establish positive emotional connections.

User perceptual capability evaluation indicators can help understand the characteristics and limitations of users in different perceptual domains. By understanding the visual, auditory, tactile, cognitive abilities of older adults, interface and feature designs can be optimized accordingly using these evaluation indicators to enhance usability and comprehensibility. Firstly, emotional elements can be incorporated into the design. By applying user perceptual capability evaluation indicators, the Emotional Care Design method can integrate appropriate emotional elements into the design process to provide interfaces and experiences that align more closely with user expectations. Selecting suitable emotional elements, such as friendly icons, welcoming language expressions, warm colors, etc., can increase interface recognizability, readability, and usability. Secondly, responsive design with a focus on tactile feedback. Based on user perceptual capability evaluation indicators, design responsive interface elements to ensure that older users can easily click, swipe, or touch. Incorporate tactile feedback to provide users with positive tactile sensations during interactions, enhancing satisfaction. Additionally, personalized and guided interaction design can be employed. According to user perceptual capability evaluation indicators, provide personalized settings options, allowing older users to adjust based on their perceptual capabilities, reducing cognitive burdens. Design guided interactions to lead users in gradually adapting to the new interface, making their cognitive adjustment more comfortable.

## **DESIGN CASE AND CASE ANALYSIS**

### **Intelligent Medical Box Interface Design Case**



Interface design was carried out for a smart home medical box product for the elderly, based on the design methods mentioned earlier. In the design process, careful consideration was given to the characteristics of the perceptual abilities of older adults. The interface is kept simple and clear, with large text, a maximum of three layers for accessibility. Additionally, it incorporates features such as voice interaction, tactile feedback, and audio prompts. The design scheme effect diagram is shown in Figure 8.



Source: This study.

Figure 8: Intelligent medical box interface design effect diagram.

### Design Case Analysis

At the beginning of the design, some well-known smart home brand products were selected, such as Google Nest Hub, Amazon Echo Show, Apple Home Pod and other interactive interfaces. From the aspects of user interface design, interactive operation design, functional design, accessibility design and user experience, it is found that some user interfaces have problems such as complex interface, cumbersome operation, too small font, untimely feedback, and dislike of the elderly. At the same time, some advantages and innovations are also found, such as voice interaction, beautiful interface and diverse functions.

In the design of the interactive interface of the intelligent medical box, the creative design points based on the evaluation of perceptual ability are mainly reflected in simplifying the interface level, blue-green color matching scheme, guiding icon, reasonable interface layout, icon size matching, visual and auditory linkage and other aspects.

First of all, on the basis of investigation and perception ability evaluation, the product function is analyzed hierarchically, and the design is in a three-tier interactive interface, such as the user login interface on the home page of the interface, which can realize one-click login and picture printing function. After clicking the picture print icon, there will be result prompts during the printing process or the completion of the printing. The interface after login is the main interface that integrates all the functions of the product. The layout of the main interface is simple. Through the guiding icon with picture and clear text, the user can enter the interface of 'blood glucose measurement', 'blood pressure measurement', 'heart rate measurement' and 'medication reminder' at a glance. The third layer of the measurement interface has a graphical visualization of the measurement tips, as well as with the 'smile' expression of the results suggest that both cordial and eye-catching. All the functions are realized in the three-layer interface, which greatly reduces the difficulty of operation and improves the ease of use of the interface. The use of guiding icons improves the readability and identifiability of the interface.

Secondly, the interface adopts a blue-green color scheme, and the warm and cold colors are balanced. Blue and green belong to cold colors, which are usually considered to have the characteristics of calmness, relaxation and comfort. Combining these two colors can achieve a balance between cold and warm colors, so that the interface looks neither too cold nor too warm, which is in line with the aesthetic preferences of elderly users. Blue-green color matching is not only natural and environmentally friendly, but also has high visual comfort, which makes users who use products or applications for a long time less likely to feel visual fatigue. Therefore, blue-green color matching has certain advantages in user experience. In addition, blue is usually associated with professionalism and credibility, so in many fields, the blue-green color scheme of the interface can convey the credibility and professionalism of the product. At the same time, blue-green is also easy to identify.

In addition, the case also uses a combination of graphic and voice sensory linkage design. Pronunciation results can help users with visual impairment or reading difficulties to obtain information more easily. At the same time, the graphic results can be

viewed by other users to meet various accessibility requirements. Moreover, users can choose whether to read text or listen to voice according to specific conditions and needs, which provides a more flexible user experience. And voice can also interact with users, such as answering questions or providing suggestions, thereby enhancing user engagement and interactivity.

## RESULTS AND PROSPECTS

The application effect of the perception ability evaluation method in the interactive interface design of aging smart home products is significant. By integrating the perceptual ability evaluation method into the design process, we can better understand the capabilities and limitations of elderly users in different perception fields, so as to optimize the product interaction interface and provide a more suitable user experience for them. First, the perceptual ability evaluation method can help identify the visual, auditory, tactile and cognitive challenges of older users, so as to adjust the interface elements in a targeted manner and improve recognition, ease of use and readability. Secondly, based on the evaluation results of perception ability, the design can provide personalized setting options, so that elderly users can adjust the interface according to their own perception characteristics, so as to provide a more suitable user experience for them. Third, the perception ability evaluation method can guide the design team to choose the appropriate emotional elements, such as friendly icons, warm colors and friendly language expression, to enhance the emotional resonance between the elderly users and the products. Fourthly, by simplifying the interface design and reducing the operation steps according to the cognitive characteristics of the elderly users, the cognitive burden of the elderly users can be reduced, so that they can use smart home products more easily. Fifth, the combination of perceptual ability evaluation method and emotional care design method can create a more humane, warm and caring user experience, so that elderly users feel respected and valued.

In the future, further improvement and optimization of the interactive interface design of aging smart home products need to consider the perception characteristics, cognitive ability and emotional needs of elderly users, as well as the continuous development of technology and design trends. For example, try to introduce more gesture recognition and voice control technology, so that older users can interact with smart home products more naturally and reduce dependence on complex interfaces. Virtual reality (VR) and augmented reality (AR) technologies can also be used to create a more intuitive and visual interface to help older users better understand and operate product functions. And further emphasize the participation of elderly users in the design process, through user research, feedback collection and user testing, continue to optimize the product interaction interface to ensure that it meets the actual needs of elderly users. In conclusion, further improvements and optimizations in age-friendly smart home product interface design necessitate a comprehensive consideration of user needs and technological advancements. The goal is to create interfaces that are not only more user-friendly but also closely aligned with user preferences. With technology continually evolving and the aging population trend intensifying, ongoing design innovation will play an increasingly vital role in improving the quality of life for elderly users.

## CONCLUSION

This study, based on interviews about user requirements for smart home product interfaces, analyzed the behavior, emotional changes, and pain points of elderly individuals during their use of smart home product interfaces. It identified the characteristics and changes in the perceptual abilities of older adults at the physiological, cognitive, and psychological levels, and summarized an evaluation system for the perceptual abilities of elderly individuals in smart home product interfaces. Building upon the principles of smart home product interface design, it explored design methods based on perceptual ability evaluations, providing a reference for the design of smart home product interfaces for the elderly.

Tailored to specific home product usage scenarios, aimed at improving the elderly user experience and based on the guarantee of function reachability, the study, guided by the results of perceptual ability evaluations, optimized cognitive pathways, implemented coarse operation-based interaction design, reduced the demands on cognition and fine motor skills, and used emotional care and other design methods. This resulted in the design of an elderly-friendly smart medical box interface. Overall, these efforts comprehensively enhanced elderly users' satisfaction with smart home product interfaces.

## ACKNOWLEDGMENT

This work was sponsored by the Major project of Philosophy and Social Science research in colleges and universities of Jiangsu Province (2023SJZD108), Nanjing Institute of Technology university-level scientific research innovation fund project (CKJB202211), Provincial innovation training program for College Students (20221127646Z), Ministry of Education Human Society project of China (22YJC760024), and sponsored by 2023 Qing Lan Project.

## REFERENCES

- Coşar, S., Fernandez-Carmona, M., Agrigoroaie, R., Pages, J., Ferland, F., Zhao, F., ... & Tapus, A. (2020). ENRICHME: Perception and Interaction of an Assistive Robot for the Elderly at Home. *International Journal of Social Robotics*, 12, 779-805. <https://doi.org/10.1007/s12369-019-00614-y>.
- De Barros, A. C., Leitão, R., & Ribeiro, J. (2014). Design and evaluation of a mobile user interface for older adults: navigation, interaction and visual design recommendations. *Procedia Computer Science*, 27, 369-378. <https://doi.org/10.1016/j.procs.2014.02.041>.
- Fan, A., Chen, L., Zhang, R., & Lao, R. (2023, April). Research on elderly-friendly design of mobile application user interface. In *International Conference on Artificial Intelligence and Industrial Design (AIID 2022)* (Vol. 12612, pp. 16-19). SPIE. <https://doi.org/10.1117/12.2673004>.



- Fischer, J. E., Reeves, S., Porcheron, M., & Sikveland, R. O. (2019, August). Progressivity for voice interface design. In *Proceedings of the 1st international conference on conversational user interfaces* (pp. 1-8). <https://doi.org/10.1145/3342775.3342788>.
- Granata, C., Pino, M., Legouverneur, G., Vidal, J. S., Bidaud, P., & Rigaud, A. S. (2013). Robot services for the elderly with cognitive impairment: Testing usability of graphical user interfaces. *Technology and Health Care*, 21(3), 217-231. <https://doi.org/10.3233/THC-130718>.
- Iancu, I., & Iancu, B. (2020). Designing mobile technology for the elderly: A theoretical overview. *Technological Forecasting and Social Change*, 155, 119977. <https://doi.org/10.1016/j.techfore.2020.119977>.
- Jo, T. H., Ma, J. H., & Cha, S. H. (2021). Elderly perception on the Internet of Things-based integrated smart-home system. *Sensors*, 21(4), 1284. <https://doi.org/10.3390/s21041284>.
- Khawaja, M. A., Chen, F., & Marcus, N. (2014). Measuring cognitive load using linguistic features: Implications for usability evaluation and adaptive interaction design. *International Journal of Human-Computer Interaction*, 30(5), 343-368. <https://doi.org/10.1080/10447318.2013.860579>.
- Li, Q., & Luximon, Y. (2023). Navigating the mobile applications: The influence of interface metaphor and other factors on older adults' navigation behavior. *International Journal of Human-Computer Interaction*, 39(5), 1184-1200. <https://doi.org/10.1080/10447318.2022.2050540>.
- Li, Q., & Luximon, Y. (2020). Older adults' use of mobile devices: Usability challenges while navigating various interfaces. *Behaviour & Information Technology*, 39(8), 837-861. <https://doi.org/10.1080/0144929X.2019.1622786>.
- Liu, N., Pu, Q., Shi, Y., Zhang, S., & Qiu, L. (2023). Older adults' interaction with intelligent virtual assistants: The role of information modality and feedback. *International Journal of Human-Computer Interaction*, 39(5), 1162-1183. <https://doi.org/10.1080/10447318.2022.2074667>.
- Majumder, S., Aghayi, E., Noferesti, M., Memarzadeh-Tehran, H., Mondal, T., Pang, Z., & Deen, M. J. (2017). Smart homes for elderly healthcare—Recent advances and research challenges. *Sensors*, 17(11), 2496. <https://doi.org/10.3390/s17112496>.
- Maswadi, K., Ghani, N. B. A., & Hamid, S. B. (2020). Systematic literature review of smart home monitoring technologies based on IoT for the elderly. *IEEE Access*, 8, 92244-92261. <https://doi.org/10.1109/ACCESS.2020.2992727>.
- Miraz, M. H., Ali, M., & Excell, P. S. (2021). Adaptive user interfaces and universal usability through plasticity of user interface design. *Computer Science Review*, 40, 100363. <https://doi.org/10.1016/j.cosrev.2021.100363>.
- Mitzner, T. L., Boron, J. B., Fausset, C. B., Adams, A. E., Charness, N., Czaja, S. J., ... & Rogers, W. A. (2010). Older adults talk technology: Technology usage and attitudes. *Computers in Human Behavior*, 26(6), 1710-1721. <https://doi.org/10.1016/j.chb.2010.06.020>.
- Ni T.L., Ran R., Qi N., Zhao L. & Chen Y. (2022). Aging Design of Waiting Service APP [J]. *Packaging Engineering*, 43(22), 125-133. <https://doi.org/10.19554/j.cnki.1001-3563.2022.22.014> (in Chinese).
- Pal, D., Papasratron, B., Chutimaskul, W., & Funilkul, S. (2019). Embracing the smart-home revolution in Asia by the elderly: An end-user negative perception modeling. *IEEE Access*, 7, 38535-38549. <https://doi.org/10.1109/ACCESS.2018.2808472>.
- Punchoojit, L., & Hongwarittorn, N. (2017). Usability studies on mobile user interface design patterns: A systematic literature review. *Advances in Human-Computer Interaction*, 2017. <https://doi.org/10.1155/2017/6787504>.
- Ruzic, L., Lee, S. T., Liu, Y. E., & Sanford, J. A. (2016). Development of universal design mobile interface guidelines (UDMIG) for aging population. In *Universal Access in Human-Computer Interaction. Methods, Techniques, and Best Practices: 10th International Conference, UAHCI 2016, Held as Part of HCI International 2016, Toronto, ON, Canada, July 17-22, 2016, Proceedings, Part I 10* (pp. 98-108). Springer International Publishing. [https://doi.org/10.1007/978-3-319-40250-5\\_10](https://doi.org/10.1007/978-3-319-40250-5_10).
- Ruzic, L., & Sanford, J. A. (2017). Universal design mobile interface guidelines (UDMIG) for an aging population. *Mobile e-Health*, 17-37. [https://doi.org/10.1007/978-3-319-60672-9\\_2](https://doi.org/10.1007/978-3-319-60672-9_2).
- Sauer, J., Sonderegger, A., & Schmutz, S. (2020). Usability, user experience, and accessibility: Towards an integrative model. *Ergonomics*, 63(10), 1207-1220. <https://doi.org/10.1080/00140139.2020.1774080>.
- Sooraj, S. K., Sundaravel, E., Shreesh, B., & Sireesha, K. (2020, September). IoT smart home assistant for physically challenged and elderly people. In *2020 International Conference on Smart Electronics and Communication (ICOSEC)* (pp. 809-814). IEEE. <https://doi.org/10.1109/ICOSEC49089.2020.9215389>.
- Zhang, Q., Li, M., & Wu, Y. (2020). Smart home for elderly care: Development and challenges in China. *BMC Geriatrics*, 20(1), 1-8. <https://doi.org/10.1186/s12877-020-01737-y>.
- Zhou, C., Dai, Y., Huang, T., Zhao, H., & Kaner, J. (2022). An empirical study on the influence of smart home interface design on the interaction performance of the elderly. *International Journal of Environmental Research and Public Health*, 19(15), 9105. <https://doi.org/10.3390/ijerph19159105>.
- Zhou H.Y. & Wang J.L. (2023). Design of Elderly-oriented Bathroom Products Based on Kano-QFD. *Packaging Engineering (Art edition)*, 44(4), 150-157. <https://doi.org/10.19554/j.cnki.1001-3563.2023.04.018> (in Chinese).
- Zhu, D., Zhang, B., Wu, J., Zhao, L., Jing, Y., Wang, D., ... & Ohashi, T. (2022). Social inclusion in an aging world: Envisioning elderly-friendly digital interfaces. In *Human Interaction, Emerging Technologies and Future Systems V: Proceedings of the 5th International Virtual Conference on Human Interaction and Emerging Technologies, IHIET 2021, August 27-29, 2021 and the 6th IHIET: Future Systems (IHIET-FS 2021), October 28-30, 2021, France* (pp. 1082-1087). Springer International Publishing. [https://doi.org/10.1007/978-3-030-85540-6\\_139](https://doi.org/10.1007/978-3-030-85540-6_139).

## Intervention Mechanism for Green Disposal Behavior in the Gamification Context

Jingtao Yin<sup>1,\*</sup>

Tuxia Chen<sup>2</sup>

Yixun Lin<sup>3</sup>

Helen S. Du<sup>4</sup>

\*Corresponding author

<sup>1</sup> Jingtao Yin\*, Guangdong University of Technology, Guangzhou, China, 2112208035@mail2.gdut.edu.cn

<sup>2</sup> Tuxia Chen, Guangdong University of Technology, Guangzhou, China, 1767981430@qq.com

<sup>3</sup> Yixun Lin, Beihang University, Beijing, China, yxlin@buaa.edu.cn

<sup>4</sup> Helen S. Du, Guangdong University of Technology, Guangzhou, China, hsdu@gdut.edu.cn

### ABSTRACT

Green disposal behavior is a key behavioral outcome in environmental protection. Existing research indicates that gamification platforms can stimulate green behavior in users. However, in the context of gamification, users' green disposal behavior intervention mechanism is unexplored. Based on goal frame theory, this study investigates the decision-making process of green disposal behavior of users on gamification platforms. Three findings emerged from analyzing user preferences, interactions, and gamification reward and punishment interventions. The results provide guidance and suggestions for designing the gamification platform, as well as the promotion of participation in social green disposal behavior.

*Keywords:* Gamification, green disposal behavior, goal frame theory, intervention mechanism.

### INTRODUCTION

Environmental protection has become an increasingly crucial global concern. Specifically, the production of plastics (De Fano et al., 2022), electrical and electronic equipment (Shittu et al., 2021) is increasing, while collection and recycling rates remain low. Green disposal behavior is considered an important behavioral outcome (e.g., Borthakur and Govind, 2019; Fan et al., 2022). It is the final critical stage of the three environmentally responsible consumption stages (Gupta and Agrawal, 2019), which includes repairing and reusing items, as well as properly disposing of rarely used (unused) items and waste. Furthermore, in terms of carbon footprint, the weakest link can be found at the terminal point (Papaioannou et al., 2016). Therefore, guiding individuals towards adopting green disposal behaviors in their daily lives is congruent with contemporary trends.

In recent years, gamification programs have emerged as a tool for guiding individuals toward green behaviors, yielding positive results (Briones et al., 2018). For example, as an online platform that utilizes gamification techniques (Du et al., 2020), Ant Forest establishes carbon accounts for users and incentivizes them to engage in environmentally friendly behaviors. From 2016 to 2021, the platform achieved a carbon emission reduction of 12 million tons (Xu et al., 2022). Users can receive various rewards or punishments (such as medals and points) upon completion or incompleteness of game tasks on this platform. Compared to tangible incentives and penalties, gamification systems offer users a less costly yet more enjoyable form of motivation. Additionally, external rewards and punishments have the potential to serve as intervention factors. To clarify the potential factors affecting the green disposal behavior of users, their behavioral characteristics and needs are analyzed in a gamification system. This is of great significance for enterprises to build platforms and achieve sustainable environmental development.

Individual green disposal behavior will be affected by many aspects, such as an individual's subjective awareness of green behavior (Robertson and Barling, 2013). According to the goal frame theory, people's behavior is influenced by multiple goals. Hedonic, gain, and normative are overarching goals, each with its sub-goals (Lindenberg and Steg, 2007). Existing research investigated goals of three dimensions as psychological motivation at the same time (eg., Du et al., 2020; Tang et al., 2020; Dastjerdi et al., 2019). Due to the existence of three kinds of goals, individuals will have a certain goal preference due to their characteristics. Under specific goals, individuals will have their own behavioral preferences (Steg et al., 2014). On the one hand, individuals have bounded rationality, they are characterized by the pursuit of utility maximum, so benefit affects the behavioral decision-making process. Moreover, when individuals become users of online platforms, they are influenced by the environment in which they live. For example, in gamification platforms, users can interact with friends, and they can choose to follow or avoid specific behaviors by observing the effectiveness of friends' behaviors. Zhang(2019) evidenced that users' behaviors are affected by their social networks. Some scholars demonstrated that neighbor relationships (Pei, 2019) and daily social networks (Pedersen and Manhice, 2020) can stimulate users' green disposal behavior. On the other hand, users' behaviors are also impacted by external circumstances such as the rewards and punishments intervention. The rewards and punishments intervention in the gamification system has a positive effect (reward) (Plangger et al., 2022; Guo et al., 2022) and a negative effect (punishment) (Diefenbach and Müssig, 2019). Therefore, the optimal design of gamification rewards and

punishments to promote green disposal behavior is unexplored. It is potentially significant to thoroughly consider the joint effect of user preferences, user interactions, and gamification rewards and punishments intervention mechanisms when facilitating users' green disposal behavior levels in the user population.

In summary, we aim to address the following questions: 1. How do users with different preferences, interactions, and gamification intervene in users' green disposal behavior (accept or refuse) during their use of the gamification platform? 2. What is the best combination of gamification rewards and punishments intervention to stimulate users' green disposal behavior?

In this study, goal frame theory is used as the basis for the behavior and interactions of individuals in a group. Numerical simulation experiments with Python were performed to explore the intervention mechanism of users using the gamification platform to accept or refuse green disposal behaviors in the group. To direct people's green disposal behavior, we offer boundary conditions and theoretical foundations for governments and other related industries. In addition, we provide a reference for corporate promotion strategies and platform construction.

## MODEL

### Model Description and Function Characterization

#### Decision utility function construction

The user's decision about green disposal behavior is defined as  $x = \{a, b\}$ . There are two concrete cases, 'accept' and 'refuse'. In particular, we define the decision-making behavior as follows:

$$x = \begin{cases} a & \text{accept} \\ b & \text{refuse} \end{cases} \quad (1)$$

Whether users accept or refuse green disposal behaviors, there will be corresponding benefits and costs. Benefits and costs involve benefits from users accepting or refusing green disposal behaviors  $B_1$  and  $C_1$ , and costs from users accepting or refusing green disposal behaviors  $B_2$  and  $C_2$ . Moreover, we set that  $k \in [-1,1]$  is the intervention coefficient of gamification rewards and punishments.  $k_1$  and  $k_2$  denote the intervention proportion of gamification rewards and punishments.  $k_1$  is the gamification rewards value,  $k_2$  is the gamification punishments value. The higher the value of  $k_1$  or the lower the value of  $k_2$ , the higher the degree of intervention. The relevant parameters are shown in Table 1.

$$\begin{aligned} k &= k_1 \in [0,1], \text{ if } x = a \\ k &= k_2 \in [-1,0], \text{ if } x = b \end{aligned} \quad (2)$$

Table 1: Parameter and definition.

Parameter	Value range	Definition
$B_1$	$B_1 > 0$	Benefits from users accepting green disposal behaviors, such as exchanging idle items for other items they want, selling idle items to get money, protecting the environment, and promoting fresh air.
$C_1$	$C_1 > 0$	Costs from users accepting green disposal behaviors, such as time and energy spending, cause economic loss.
$B_2$	$B_2 > 0$	Benefits from users refusing green disposal behaviors, such as saving time or money.
$C_2$	$C_2 > 0$	Costs from users refusing green disposal behaviors, such as buying new items instead of exchanging idle, and the environmental pollution cost of discarding idle items.
$k_1$	$k_1 \in [0,1]$	Rewards are given by the gamified platform when users accept green disposal behaviors, such as increasing points, and props rewards.
$k_2$	$k_2 \in [-1,0]$	Punishments are given by the gamified platform when users refuse green disposal behaviors, such as decreasing points.

Source: This study.

The user's utility function includes the user's economic utility value  $U_1(x)$  and gamification rewards and punishment intervention utility provided by the external environment  $U_2(x)$ . The overall perceived utility for  $x$  can be expressed as follows:

$$G(x) = \sum \delta_i U_i(x), i = 1,2 \quad (3)$$

Based on the goal frame theory, a user's goal can be into three types, which are hedonic goal, gain goal, and normative goal. In addition, a user has three simultaneous hedonic, gain, and normative goals, but one goal dominates. Therefore, this paper divides users' overall preferences into three types, namely hedonic preference, gain preference, and normative preference. Users with three preferences focus on utility differently.  $\delta_i \in [0,1]$  is the differences in user preferences for perceived utility.

$\delta_1$  is the degree of perceiving the user's economic utility.  $\delta_2$  is the degree of perceiving the gamification rewards and punishment intervention utility. When users with hedonic preference, we set  $\delta_1 = 1, \delta_2 = U(1,2)$ . When users with gain preference, we set  $\delta_1 = \delta_2 = 1$ . When users with gain preference, we set  $x = a, \delta_1 = U(1,2), \delta_2 = 1; x = b, \delta_1 = U(0,1), \delta_2 = 1$ .

When the user accepts green disposal behavior, namely  $x = a$ . The economic utility of the user who accepts green disposal behavior is as follows:

$$U_1(x = a) = B_1 - C_1 \tag{4}$$

The gamification utility of the user who accepts green disposal behavior is as follows:

$$U_2(x = a) = k_1(B_1 - C_1) \tag{5}$$

The overall utility of the user who accepts green disposal behavior is as follows:

$$G(x = a) = (\delta_1 + \delta_2 k_1)(B_1 - C_1) \tag{6}$$

When the user refuses green disposal behavior, namely  $x = b$ . The economic utility of the user who refuses green disposal behavior is as follows:

$$U_1(x = b) = B_2 - C_2 \tag{7}$$

The gamification utility of the user who refuses green disposal behavior is as follows:

$$U_2(x = b) = k_2(B_2 - C_2) \tag{8}$$

The overall utility of the user who refuses green disposal behavior is as follows:

$$G(x = b) = (\delta_1 + \delta_2 k_2)(B_2 - C_2) \tag{9}$$

In summary,  $G(x)$  is as follow:

$$G(x) = \begin{cases} (\delta_1 + \delta_2 k_1)(B_1 - C_1) & \text{if } x = a \\ (\delta_1 + \delta_2 k_2)(B_2 - C_2) & \text{if } x = b \end{cases} \tag{10}$$

**Design of users interaction process**

According to the six-degrees theory, people form strong social networks. The higher the degree of preference dissimilarity between two people, the lower the likelihood of their mutual imitation. The imitation threshold between three preferences among users is as follows (Cheng et al., 2019; Chen and Gao, 2020).

$$Mapping(P_i, P_j) \in (0,1), i, j = h, g, n \tag{11}$$

Specifically,  $Mapping(P_h, P_h) = U(0.8, 1)$  ,  $Mapping(P_h, P_g) = U(0.3, 0.8)$  ,  $Mapping(P_h, P_n) = U(0, 0.3)$  ,  $Mapping(P_g, P_g) = U(0.8, 1), Mapping(P_g, P_n) = U(0.3, 0.8), Mapping(P_n, P_n) = U(0.8, 1)$ .

Moreover, users calculate the utility of themselves and others. Users will consider imitating others who have higher utility. According to Dai et al.(2013), The probability of imitation is as follows:

$$P_{(i \rightarrow j)} = \frac{1}{1 + \exp\left(-\frac{(G_j - G_i)}{K}\right)} \tag{12}$$

$K$  is the selection intensity measuring the irrational choices by the user. In order to control the heterogeneity among individuals, we set the  $k = 1$  (Dai et al., 2013).  $P_{(i \rightarrow j)}$  is the probability of user  $i$  imitating user  $j$ . User  $j$  is the largest benefit among the connected friends of user  $i$ .  $G_i$  and  $G_j$  are the payoff values of user  $i$  and user  $j$  respectively. User  $i$  will compare with  $P_{i \rightarrow j}$  and  $Mapping(P_i, P_j)$ . If  $P_{i \rightarrow j} \in Mapping(P_i, P_j)$ , user  $i$  will imitate other. On the contrary, the user does not imitate others, but can still choose their action again the next time. At this point, users with different preferences produce different results in their own behavior. In the environmental context, normative goal imply acting pro-environment, while gain and hedonic goals tend to not act in an environmentally sound manner (Lindenberg and Steg, 2007). Therefore, we set the probability that gain

and hedonic preferences users accept green disposal behavior the next time after the imitation failure is 0.5. The probability of normative preference users accepting green disposal behavior at the next time after the imitation failure is 0.7.

### SIMULATION ANALYSIS AND RESULTS

In order to control the variables, we set some initial values before the numerical simulation experiment. The specific values of parameters are  $B_1 = 10$ ,  $C_1 = 6$ ,  $B_2 = 9$ ,  $C_2 = 7$ . The total number of users in a group is 1000. The interaction duration is set to 100 days. In the group, 30% of the users accepted green disposal behavior at the initial time. If users have no contact with others for 30 days, the friend relationship will not exist. To ensure the accuracy of the simulation results, experiments are repeated 50 times each time and the average is taken as the final result.

#### Influence of User Preference on Green Disposal Behavior

To investigate the variance in users' green disposal behaviors under different user preference distributions, we conduct four simulation experiments, which respectively integrate the extreme distributions of the three preference types and a mixed population. In addition, we integrate the proportion of hedonic, gain, and normative preference users in the mixed population to be 1:1:1. The results of four simulation experiments demonstrate that different preferences lead to distinct evolution results for users' green disposal behaviors (accept vs. refuse). In particular, we set parameters of gamification rewards and punishments using random numbers between 0 and 1, between -1 and 0. Each user is initially set to have 6 friends.

When all users in the system exhibit hedonic preference (i.e., their motivation towards hedonic goals is infinite and overtaking other goal motivations), the simulation results of the two scenarios with or without gamification intervention are shown in Figure 1.

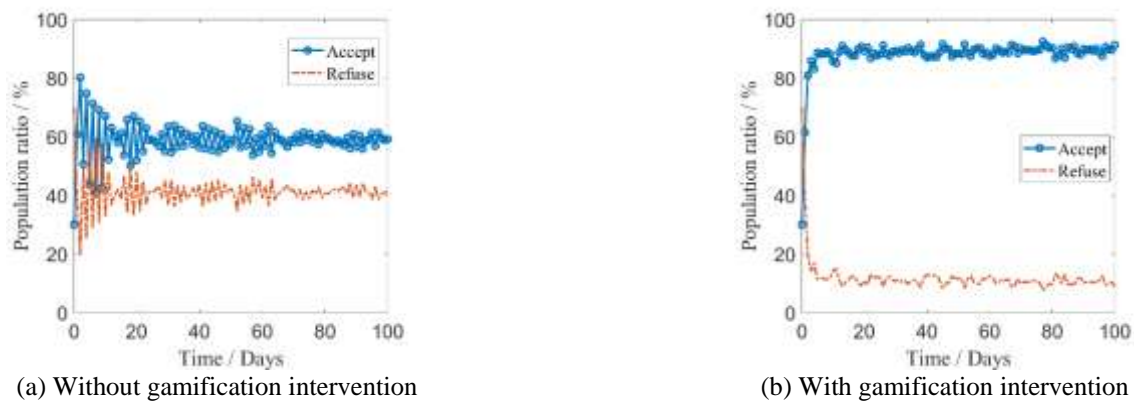

Source: This study.

Figure 1: Hedonic preference users.

Specifically, Figure 1(a) illustrates the simulation results without gamification intervention, indicating that the number of users exhibiting refuse green disposal behavior surpasses accept green disposal behavior. Figure 1(b) illustrates the simulation results with gamification intervention. The proportion of users who accept green disposal behavior has increased significantly. This result can be attributed that users with hedonic preferences are more focused on pleasurable experiences, so the effect of gamified experiences on them is very pronounced.

When all users in the system exhibit gain preference (i.e., their motivation towards gain goals is infinite and overtaking other goal motivations), the simulation results of the two scenarios with or without gamification intervention are shown in Figure 2.

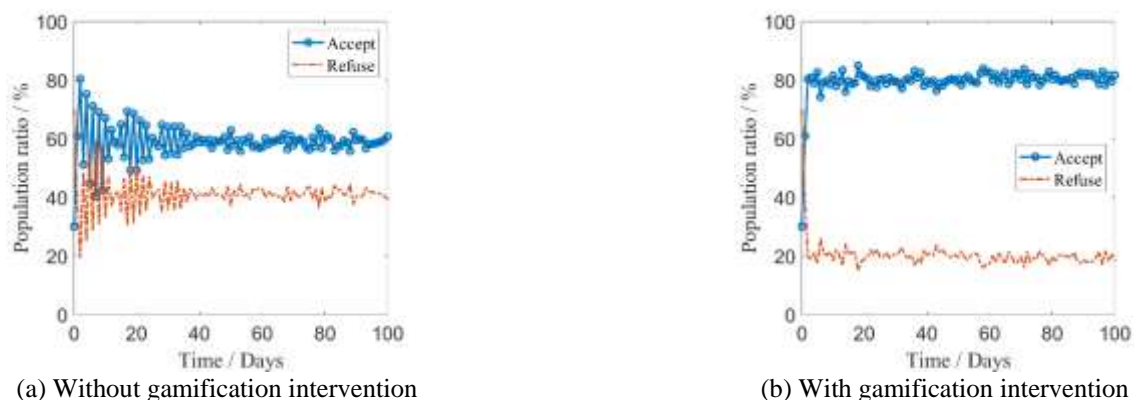

Source: This study.

Figure 2: Gain preference users.

Specifically, Figure 2(a) shows the simulation results without gamification intervention, revealing little gap between the number of users who accept and refuse green disposal behavior. It should be noted that gain preference users exhibit greater rationality and caution. Currently, insufficient benefits are derived from acceptance of green disposal behavior, so fails to provide sufficient motivation for users to adopt such behavior. Consequently, the number of users who accept green disposal behavior is nearly with the number who refuse. Figure 2(b) shows the simulation results with gamification intervention. The result shows that the number of users who accept green disposal behavior is higher than the number who refuse. Under the gamification intervention, external rewards and punishments motivate users to accept green disposal behavior.

When all users in the system exhibit normative preference (i.e., their motivation towards normative goals is infinite and overtaking other goal motivations), the simulation results of the two scenarios with or without gamification intervention are shown in Figure 3.

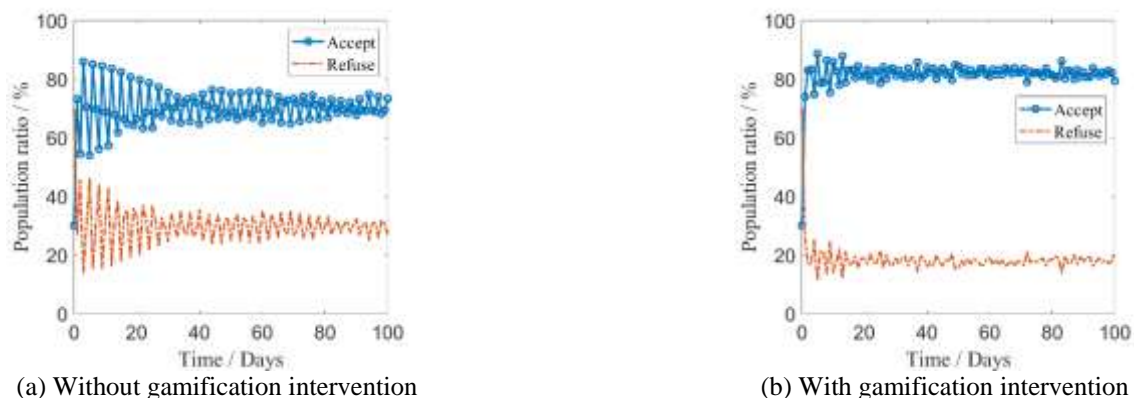

Source: This study.

Figure 3: Normative preference users.

Specifically, Figure 3(a) shows the simulation results without gamification intervention. The result shows that the number of users who accept green disposal behavior is higher than the number who refuse. This phenomenon is attributed to the normative preference that users tend to be environmentally friendly, and have a high probability of accepting green disposal behavior. Figure 3(b) shows the simulation result with gamification intervention. The final result shows that the number of users who accept green disposal behavior is much higher than the number who refuse. Since normative preferences users have a strong awareness of environmental protection, gamification interventions provide external support and nudge to accept green disposal behaviors.

Next, we set the ratio of users in the population is 1:1:1 among hedonic preference, gain preference, and normative preference. At the moment, the user population is formed by a mixture of hedonic preference, gain preference, and normative preference at the same time. This makes the simulation more realistic and applicable to real-world scenarios. The corresponding simulation results are shown in Figure 4.

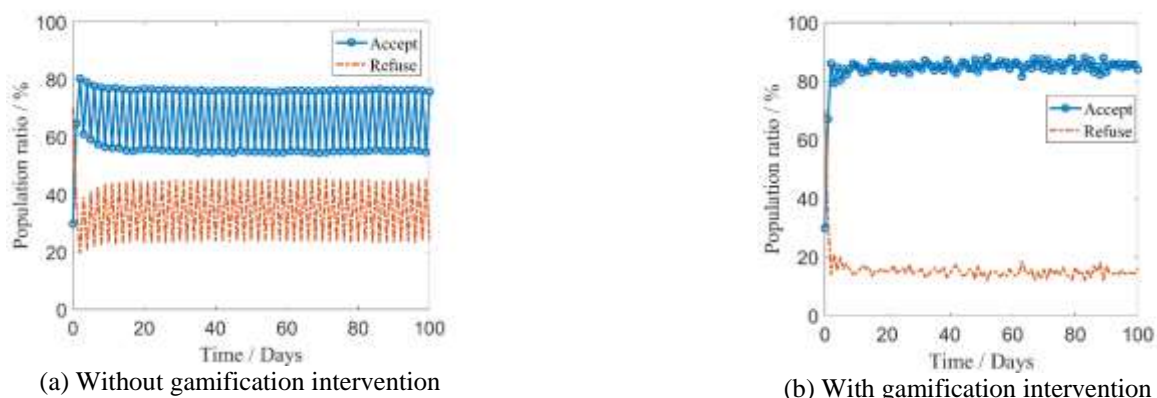

Source: This study.

Figure 4: Mixed preference users

Specifically, Figure 4(a) shows the simulation results without gamification intervention. The results show a steady trend, and the number of users who accept green disposal behavior is higher than the number who refuse. Although varying preference tendencies and imitation thresholds among mixed preference populations, users with three preferences all do not intentionally harm the environment (Lindenberg and Steg, 2007). Therefore, users in the system are more likely to transition from refusing to accepting green disposal behavior. Figure 4(b) shows the simulation results with gamification intervention. External gamification reward and punishment intervention can effectively promote users' acceptance of behavior.



### Influence of User Connections on Green Disposal Behavior

We investigate the variance in users' green disposal behaviors under different user connections (i.e., the number of friends the user interacts with). Based on the six-degrees theory and the Rule of 150, the value of the network size ranges from 6 to 150 users. In general, the user distribution is initially set to a mixed population (i.e., hedonic preference users: gain preference users: normative preference users = 1:1:1). Parameters of gamification rewards and punishments using random numbers between 0 and 1, between -1 and 0. The simulation results are shown in Figure 5.

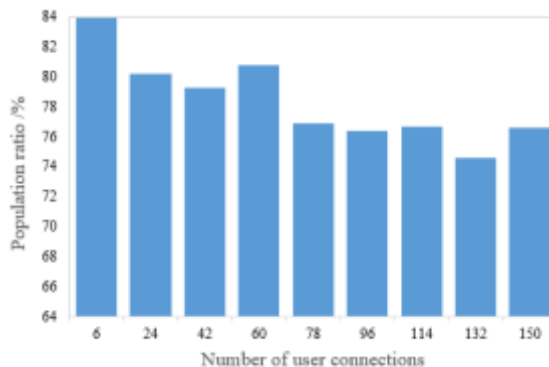

Source: This study.

Figure 5: The number of user connections ranges from 6 to 150.

The result shows that the proportion of users exhibiting green disposal behavior is the highest (approaching 84%) when the number of network connections is 6. When the number of users connected is between 24 and less than 150, the proportion drops to 74%-80%. In summary, as the number of connections increases, the ratio of users accepting green disposal behaviors decreases. The population ratio decreases significantly after 6 people. This is because while one can interact with 150 people, most relationships are weak.

Additionally, we narrow down the range of variations in the number of users. We set the number of network connections to be 2, 4, 6, 8, and 10 respectively, as shown in Figure 6. The results show that when the number of network connections is less than 10, the population of users who accept green disposal behavior does not change significantly. Moreover, the evolution path is more stable when the number of users in the network is smaller. The reason is that less influence of potential intervention when the smaller number of people in the network, thus stability is easier to maintain.

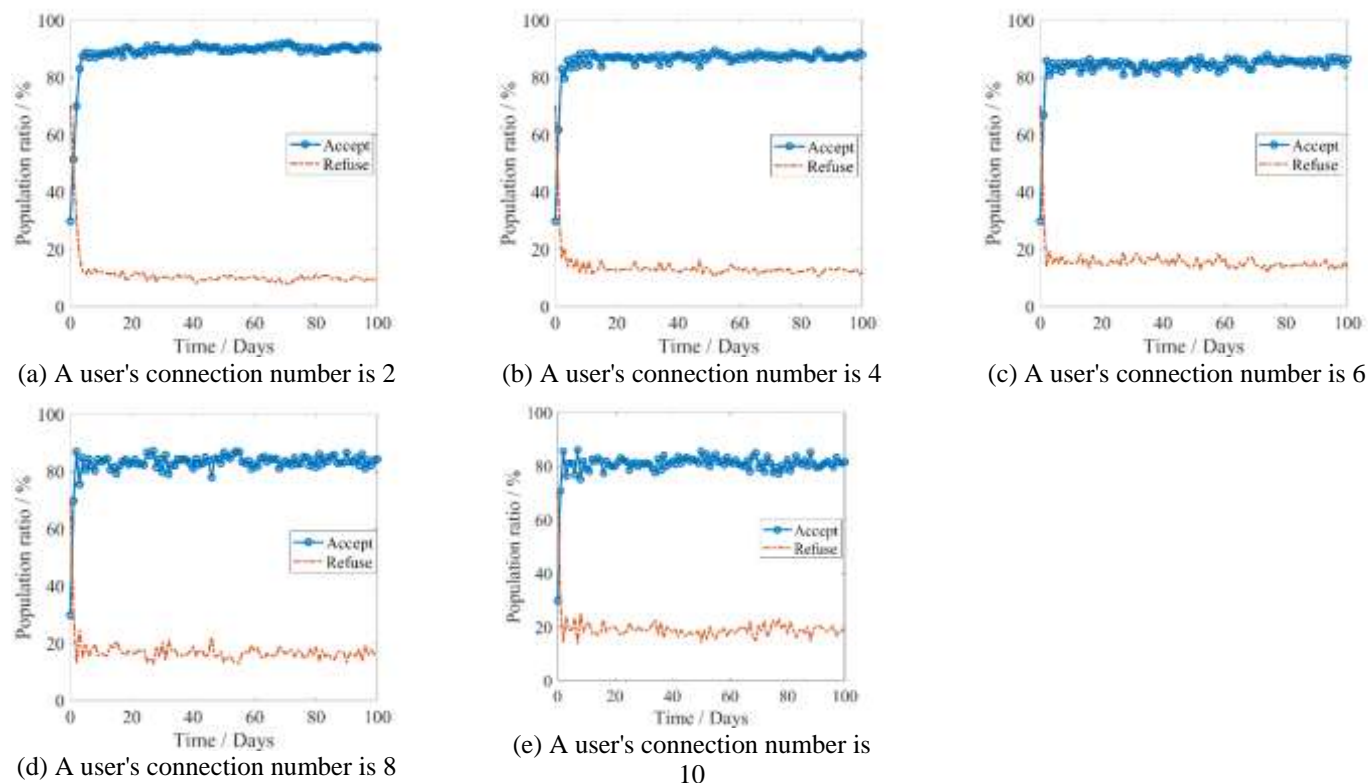

Source: This study.

Figure 6: The number of user connections ranges from 2 to 10.



### Influence of Gamification Rewards and Punishments Intervention on Green Disposal Behavior

In this section, we explore the optimal reward and punishment strategy by setting the intervention strength of gamification reward and punishment. Gamification intervention includes gamification reward intervention  $k_1$  and gamification punishment intervention  $k_2$ . In order to guide users to accept green disposal behaviors, we set gamification intervention parameters as shown in Table 2.

Table 2: Gamification rewards and punishments parameters.

High reward		Low reward		High punishment		Low punishment	
H1	H2	H3	H4	L1	L2	L3	L4
[0.75, 1]	[0.5, 0.75]	[0.25, 0.5]	[0, 0.25]	[-1, -0.75]	[-0.75, -0.5]	[-0.5, -0.25]	[-0.25, 0]

Source: This study.

In general, the user distribution is initially set to a mixed population (i.e., hedonic preference: gain preference: normative preference= 1:1:1). The 16 results of the gamification intervention are discussed. Firstly, the parameters set for high reward and high punishment modes and the proportion of users accepting green disposal behavior are shown in Table 3. The simulation results are shown in Figure 7.

Table 3: High reward and high punishment.

Modes		Proportion of users accepting green disposal behavior	Figures
High reward and high punishment	H1, L1	94.87%	Figure 7(a)
	H1, L2	89.84%	Figure 7(b)
	H2, L1	93.76%	Figure 7(c)
	H2, L2	89.15%	Figure 7(d)

Source: This study.

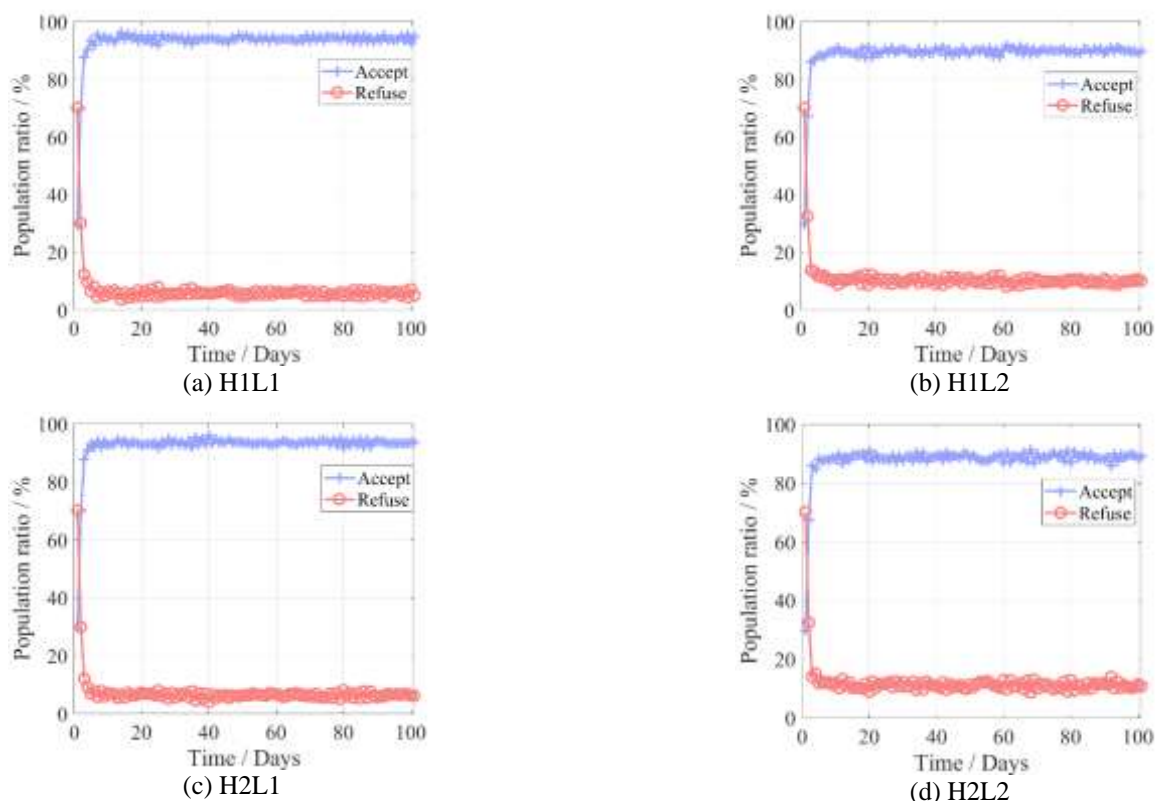

Source: This study.

Figure 7: The simulation results of high reward and high punishment.

Specifically, more users accept green disposal behavior than refuse in four cases. When  $k_1 = H_1 \in [0.75, 1]$ ,  $k_2 = L_1 \in [-1, -0.75]$ , the proportion of users accepting green disposal behavior is 94.87%, which is the best result in high reward and high punishment mode. When  $k_1 = H_2 \in [0.5, 0.75]$ ,  $k_2 = L_2 \in [-0.75, -0.5]$ , the proportion of users accepting green disposal behavior is 89.15%, which is the worst result in high reward and high punishment mode.

Secondly, the parameters set for high reward and low punishment modes and the proportion of users accepting green disposal behavior are shown in Table 4. The simulation results are shown in Figure 8.

Table 4: High reward and low punishment.

Modes		Proportion of users accepting green disposal behavior	Figures
High reward and low punishment	H1, L3	84.60%	Figure 8(a)
	H1, L4	75.27%	Figure 8(b)
	H2, L3	82.47%	Figure 8(c)
	H2, L4	75.90%	Figure 8(d)

Source: This study.

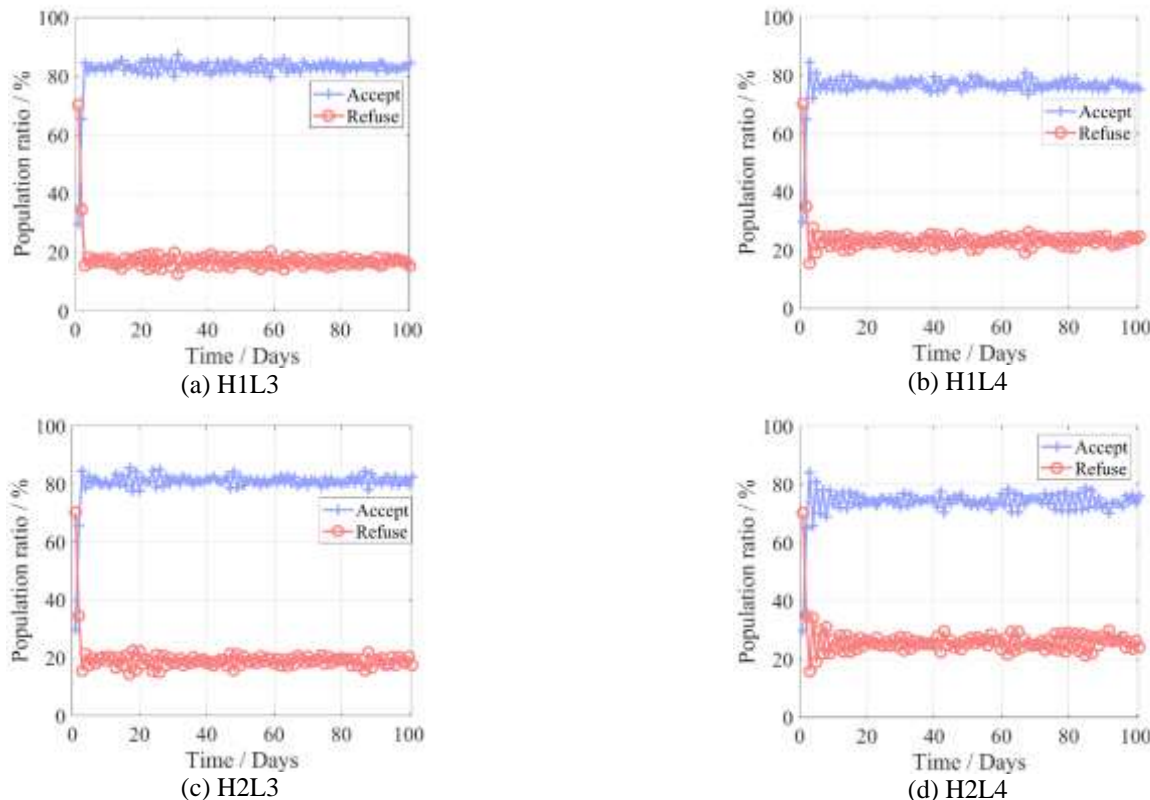

Source: This study.

Figure 8: The simulation results of high reward and low punishment.

Specifically, more users accept green disposal behavior than refuse in four cases. When  $k_1 = H_1 \in [0.75, 1]$ ,  $k_2 = L_3 \in [-0.5, -0.25]$ , the proportion of users accepting green disposal behavior is 84.60%, which is the best result in high reward and low punishment mode. When  $k_1 = H_1 \in [0.75, 1]$ ,  $k_2 = L_4 \in [-0.25, 0]$ , the proportion of users accepting green disposal behavior is 75.27%, which is the worst result in high reward and low punishment mode.

Thirdly, the parameters set for low reward and high punishment modes and the proportion of users accepting green disposal behavior are shown in Table 5. The simulation results are shown in Figure 9.

Table 5: Low reward and high punishment.

Modes		Proportion of users accepting green disposal behavior	Figures
Low reward and high punishment	H3, L1	92.87%	Figure 9(a)
	H3, L2	89.64%	Figure 9(b)
	H4, L1	93.14%	Figure 9(c)
	H4, L2	86.03%	Figure 9(d)

Source: This study.

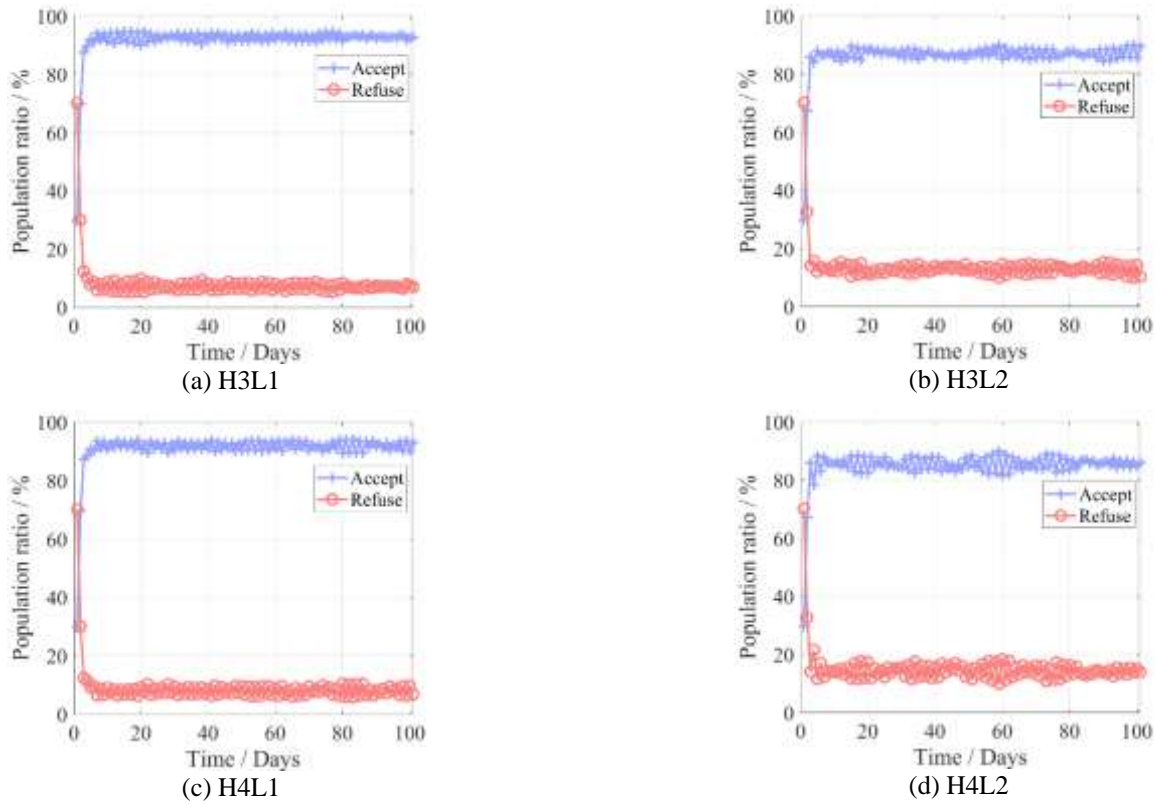

Source: This study.

Figure 9: The simulation results of low reward and high punishment.

Specifically, more users accept green disposal behavior than refuse in four cases. When  $k_1 = H_3 \in [0.25, 0.5]$ ,  $k_2 = L_1 \in [-1, -0.75]$ , the proportion of users accepting green disposal behavior is 92.87%, which is the best result in low reward and high punishment mode. When  $k_1 = H_4 \in [0, 0.25]$ ,  $k_2 = L_2 \in [-0.75, -0.5]$ , the proportion of users accepting green disposal behavior is 86.03%, which is the worst result in low reward and high punishment mode.

Lastly, the parameters set for low reward and low punishment modes and the proportion of users accepting green disposal behavior are shown in Table 6. The simulation results are shown in Figure 10.

Table 6: Low reward and low punishment.

Modes		Proportion of users accepting green disposal behavior	Figures
Low reward and low punishment	H3, L3	78.29%	Figure 10(a)
	H3, L4	72.60%	Figure 10(b)
	H4, L3	74.59%	Figure 10(c)
	H4, L4	73.40%	Figure 10(d)

Source: This study.

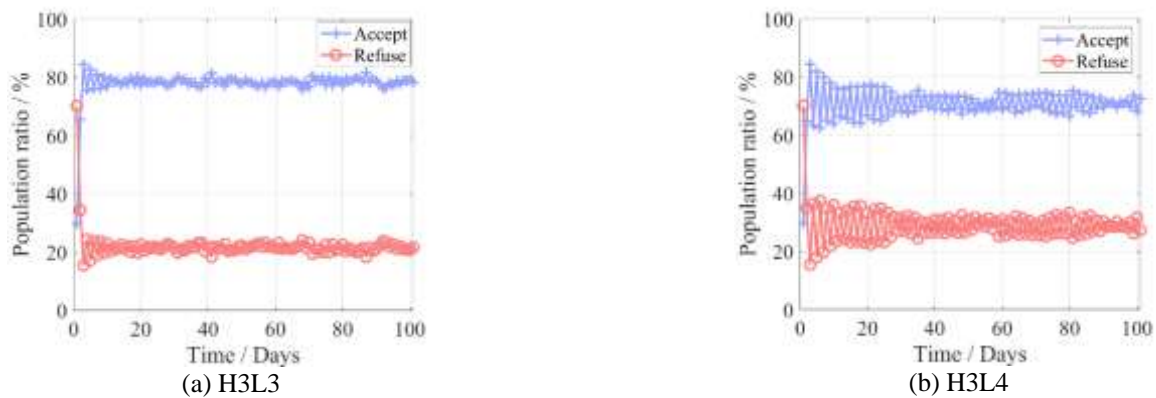

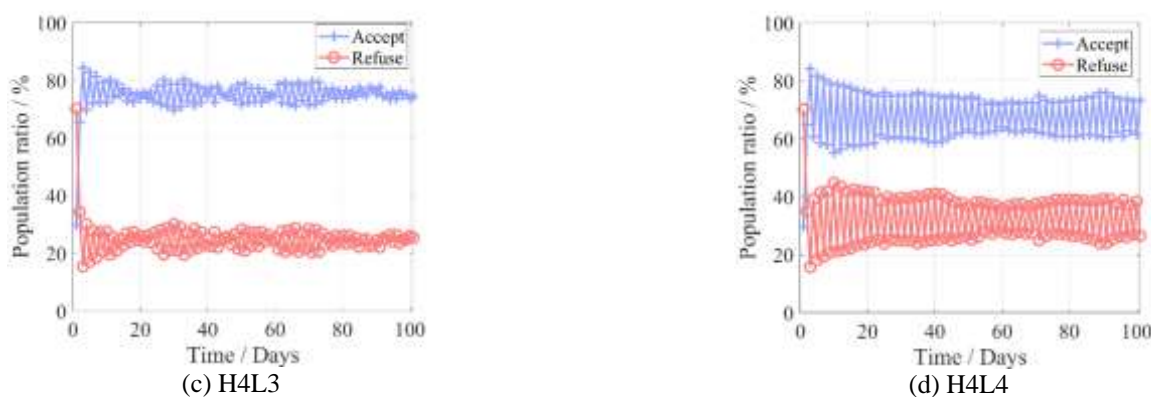

Source: This study.

Figure 10: The simulation results of low reward and low punishment.

Specifically, more users accept green disposal behavior than refuse in four cases. When  $k_1 = H_3 \in [0.25, 0.5]$ ,  $k_2 = L_3 \in [-0.5, -0.25]$ , the proportion of users accepting green disposal behavior is 78.29%, which is the best result in low reward and low punishment mode. When  $k_1 = H_3 \in [0.25, 0.5]$ ,  $k_2 = L_4 \in [-0.25, 0]$ , the proportion of users accepting green disposal behavior is 72.60%, which is the worst result in low reward and low punishment mode.

### Discussion

There are three findings in this study: (1) Regardless of which users' preferences accounted for the highest proportion or mixed preferences in the group, the results with gamification intervention are better than without. Moreover, the higher proportion of users in the group with normative preferences, the higher the proportion of users who accept green disposal behavior. (2) A user's connection number less than 10 is optimal. There are fewer connections between users and results are more stable in the system. (3) With gamification intervention, the optimal gamification intervention is high reward and high punishment, followed by low reward and high punishment, then high reward and low punishment, and the least effective is low reward and low punishment.

### CONCLUSIONS

Although existing research (Chen and Gao, 2020; Chen and Gao, 2021; Cheng et al., 2019) has explored user characteristics, users' interaction and external intervention will affect users' green behavior. However, research on the impact of external gamification rewards and punishments intervention and the impact of internal individual goal preference mechanisms on users' green disposal behavior is limited. Based on goal frame theory, social interaction, and gamification intervention, this study constructs a model and explores the impact of different influences on the green disposal behavior of users in a population. Contributions of this study are as follows.

Theoretically, this study identifies three user preferences in a gamification context based on goal frame theory. Compared with the three types of users (Cheng et al., 2019), this paper provides more theoretical support for the classification of users. The intrinsic role of preference in not only individual but also interaction is deeply explored. Moreover, the content of user interactions is expanded. Compared with based on the six-degrees theory which considers a system consisting of only six people around the user (Cheng et al., 2019), we suppose each user interacts with far more than six people on online platforms. Finally, we broaden the research on gamification rewards and punishment intervention. Based on the gamification context, this study investigates green disposal behavior under 16 combinations of gamification rewards and punishments intervention. Although existing research has indicated government subsidies and policy rewards intervention (Chen and Gao, 2020), and price intervention of waste recycling in the green environment (Chen and Gao, 2021), research on gamification intervention is limited.

Practically, this study finds that the users connect with more friends, and the proportion of accepting green disposal behavior is more unsatisfactory. Therefore, when guiding users toward green disposal behavior, the relevant departments should control the number of user connections in the guided population. Gamification platform designers can adopt strategies of gamification with high rewards and high punishments to increase the number of users who accept green disposal behavior. Local governments can choose green gamification information systems with high rewards and high punishments to achieve more efficient expected results.

Some limitations also be in this paper. Firstly, according to Park and Kim (2022), we set parameters for gamification rewards and punishment intervention. However, rewards and punishments are diversified. For example, rewards can distinguish between self-directed rewards and altruistic rewards (Hwang and Choi, 2020). Different punishments such as peer punishment, centralized punishment, and third-party punishment will have different influences (Wang et al., 2018). Therefore, future research may further refine the content, object (e.g., oneself or friends), and reward scheme (e.g., realistic feedback or delayed gratification). In addition, the simulation experiments take the form of numerical simulations, which is supported by the existing research. The related conclusions proposed in this paper can be further tested with real data and real cases in the future.



## ACKNOWLEDGMENT

This work is partially supported by the National Natural Science Foundation of China (72072040).

## REFERENCES

- Borthakur, A., & Govind, M. (2019). Computer and mobile phone waste in urban India: An analysis from the perspectives of public perception, consumption, and disposal behavior. *Journal of Environmental Planning and Management*, 62(4), 717-740. <https://doi.org/10.1080/09640568.2018.1429254>
- Briones, A. G., Chamoso, P., Rivas, A., Rodríguez, S., De La Prieta, F., Prieto, J., & Corchado, J. M. (2018). Use of gamification techniques to encourage garbage recycling: A smart city approach. In *Knowledge Management in Organizations: 13th International Conference* (pp. 674-685), KMO 2018, Žilina, Slovakia, August 6–10.
- Chen, L., & Gao, M. (2020). A new learning interaction rule for municipal household waste classification behavior based on multi-agent-based simulation. *Journal of Cleaner Production*, 271, 122654. <https://doi.org/10.1016/j.jclepro.2020.122654>
- Chen, L., & Gao, M. (2021). Formal or informal recycling sectors? Household solid waste recycling behavior based on multi-agent simulation. *Journal of Environmental Management*, 294, 113006. <https://doi.org/10.1016/j.jenvman.2021.113006>
- Cheng, X., Long, R., Chen, H., & Yang, J. (2019). Does social interaction have an impact on residents' sustainable lifestyle decisions? A multi-agent simulation based on regret and game theory. *Applied Energy*, 251, 113366. <https://doi.org/10.1016/j.apenergy.2019.113366>
- Dai, Q., Li, H., Cheng, H., Zhang, M., & Yang, J. (2013). The effects of nonlinear imitation probability on the evolution of cooperation. *Chaos, Solitons & Fractals*, 56, 53-58. <https://doi.org/10.1016/j.chaos.2013.07.001>
- Dastjerdi, A. M., Kaplan, S., e Silva, J. D. A., Nielsen, O. A., & Pereira, F. C. (2019). Use intention of mobility-management travel apps: The role of users' goals, technophile attitude, and community trust. *Transportation Research Part A: Policy and Practice*, 126, 114-135. <https://doi.org/10.1016/j.tra.2019.06.001>
- De Fano, D., Schena, R., & Russo, A. (2022). Empowering plastic recycling: Empirical investigation on the influence of social media on consumer behavior. *Resources, Conservation and Recycling*, 182, 106269. <https://doi.org/10.1016/j.resconrec.2022.106269>
- Diefenbach, S., & Müssig, A. (2019). Counterproductive effects of gamification: An analysis on the example of the gamified task manager Habitica. *International Journal of Human-Computer Studies*, 127, 190-210. <https://doi.org/10.1016/j.ijhcs.2018.09.004>
- Du, H. S., Ke, X., & Wagner, C. (2020). Inducing individuals to engage in a gamified platform for environmental conservation. *Industrial Management & Data Systems*, 120(4), 692-713. <https://doi.org/10.1108/IMDS-09-2019-0517>
- Fan, M., Khalique, A., Qalati, S. A., Gillal, F. G., & Gillal, R. G. (2022). Antecedents of sustainable e-waste disposal behavior: The moderating role of gender. *Environmental Science and Pollution Research*, 29(14), 20878-20891. <https://doi.org/10.1007/s11356-021-17275-y>
- Guo, Y., Yuan, T., & Yue, S. (2022). Designing personalized persuasive game elements for older adults in health apps. *Applied Sciences*, 12(12), 6271. <https://doi.org/10.3390/app12126271>
- Gupta, S., & Agrawal, R. (2018). Environmentally responsible consumption: Construct definition, scale development, and validation. *Corporate Social Responsibility and Environmental Management*, 25(4): 523-536. <https://doi.org/10.1002/csr.1476>
- Hwang, J., & Choi, L. (2020). Having fun while receiving rewards?: Exploration of gamification in loyalty programs for consumer loyalty. *Journal of Business Research*, 106, 365-376. <https://doi.org/10.1016/j.jbusres.2019.01.031>
- Lindenberg, S., & Steg, L. (2007). Normative, gain, and hedonic goal frames guiding environmental behavior. *Journal of Social Issues*, 63(1), 117-137. <https://doi.org/10.1111/j.1540-4560.2007.00499.x>
- Papaioannou, T. G., Hatzis, V., & Koutsopoulos, I. (2016). Optimal design of serious games for consumer engagement in the smart grid. *IEEE Transactions on Smart Grid*, 9(2), 1241-1249. <https://doi.org/10.1109/TSG.2016.2582298>
- Park, S., & Kim, S. (2022). Points and the Delivery of Gameful Experiences in a Gamified Environment: Framework Development and Case Analysis. *JMIR Serious Games*, 10(3), e35907. <https://doi.org/10.2196/35907>
- Pedersen, J. T. S., & Manhice, H. (2020). The hidden dynamics of household waste separation: An anthropological analysis of user commitment, barriers, and the gaps between a waste system and its users. *Journal of Cleaner Production*, 242, 116285. <https://doi.org/10.1016/j.jclepro.2019.03.281>
- Pei, Z. (2019). Roles of neighborhood ties, community attachment and local identity in residents' household waste recycling intention. *Journal of Cleaner Production*, 241, 118217. <https://doi.org/10.1016/j.jclepro.2019.118217>
- Plangger, K., Campbell, C., Robson, K., & Montecchi, M. (2022). Little rewards, big changes: Using exercise analytics to motivate sustainable changes in physical activity. *Information & Management*, 59(5), 103216. <https://doi.org/10.1016/j.im.2019.103216>
- Robertson, J. L., & Barling, J. (2013). Greening organizations through leaders' influence on employees' pro-environmental behaviors. *Journal of Organizational Behavior*, 34(2), 176-194. <https://doi.org/10.1002/job.1820>
- Shittu, O. S., Williams, I. D., & Shaw, P. J. (2021). Global E-waste management: Can WEEE make a difference? A review of e-waste trends, legislation, contemporary issues and future challenges. *Waste Management*, 120, 549-563. <https://doi.org/10.1016/j.wasman.2020.10.016>
- Steg, L., Bolderdijk, J. W., Keizer, K., & Perlaviciute, G. (2014). An integrated framework for encouraging pro-environmental behaviour: The role of values, situational factors and goals. *Journal of Environmental Psychology*, 38, 104-115. <https://doi.org/10.1016/j.jenvp.2014.01.002>

- Tang, Y., Chen, S., & Yuan, Z. (2020). The effects of hedonic, gain, and normative motives on sustainable consumption: Multiple mediating evidence from China. *Sustainable Development*, 28(4), 741-750. <https://doi.org/10.1002/sd.2024>
- Wang, Q., He, N., & Chen, X. (2018). Replicator dynamics for public goods game with resource allocation in large populations. *Applied Mathematics and Computation*, 328, 162-170. <https://doi.org/10.1016/j.amc.2018.01.045>
- Watts, D. J., & Strogatz, S. H. (1998). Collective dynamics of 'small-world' networks. *Nature*, 393(6684), 440-442. <https://doi.org/10.1038/30918>
- Xu, J., Du, H. S., Shen, K. N., & Zhang, D. (2022). How gamification drives consumer citizenship behaviour: The role of perceived gamification affordances. *International Journal of Information Management*, 64, 102477. <https://doi.org/10.1016/j.ijinfomgt.2022.102477>
- Zhang, K., Xu, Y., & Liu, W. (2019). Empirical analysis of the intelligent influence factors of social network services effectiveness in e-commerce based on human learning behaviors. *Psychology Research and Behavior Management*, 12, 417-425. <https://doi.org/10.2147/PRBM.S203007>

## Introduction of Data Spaces for Data Sovereignty – Status and Recommendations for Action

Hutterer Andreas<sup>1,\*</sup>

\*Corresponding author

<sup>1</sup> Researcher, Johannes Kepler University Linz, Linz, Austria, [andreas.hutterer@jku.at](mailto:andreas.hutterer@jku.at)

### ABSTRACT

Data sovereignty is paramount in the digital era, and data spaces are often viewed as a means for organizations to cultivate this essential digital competency. However, the adoption of data spaces by organizations remains limited. Furthermore, current perspectives on data spaces tend to emphasize technical aspects while overlooking their socio-technical complexity. What's lacking are recommendations for establishing federated data spaces. To bridge this gap, the study advocates the development of recommendations through expert interviews. Targeting both academia and industry, this research employs coding techniques akin to grounded theory to offer insights and propose four key categories of recommendations: Community, Infrastructure, Interoperability, and Governance. Leveraging data spaces for data sovereignty can provide organizations with a competitive edge.

*Keywords:* Data spaces, Data sovereignty, Recommendations for action.

### INTRODUCTION

In recent years, the importance of national sovereignty in technology and Internet governance has increased significantly (Lewis, 2023). “Sovereignty is the freedom of all actors in the market to make self-determined, independent decisions and to operate in fair competition” (Plattform Industrie 4.0, 2023, p. 18). In Europe, there has been a greater focus on digital sovereignty and its importance in the use of digital platforms (Fischer et al., 2023; Kagermann et al., 2021). In the context of digitalization, it is important to distinguish between data sovereignty, digital sovereignty, and technological sovereignty (Hellmeier & von Scherenberg, 2023). The data sovereignty of organizations is often neglected because it is frequently disregarded (Lauf et al., 2022). Yet, the importance of data sovereignty as a digital literacy is increasingly recognized (Glasze et al., 2023). The goal is to empower data owner in data ecosystems and foster fair environments that benefit both individuals and organizations (Hellmeier & von Scherenberg, 2023). Organizations' biggest challenge is acquiring new competencies related to digital literacy, highlighting the often underestimated importance of data expertise in preserving data sovereignty. (Moschko et al., 2023). The growing importance of data sovereignty, which involves data controll, presents a challenge for organizations seeking to share data securely while protecting against potential leaks, particularly in cross organizational data ecosystems, i.e. data spaces (Hellmeier et al., 2023).

Data spaces are seen as a means for secure and sovereign data transfer (Otto, 2022b; Steinbuss et al., 2023). Initiatives such as the National Initiative for AI-based Transformation to the Data Economy (NITD) are pushing the establishment of a strong ecosystem, i.e., data spaces, for data driven innovations in the data economy (acatech – National Academy of Science and Engineering, 2023). Gaia-X also aims to create a secure and federated data infrastructure (Gaia-X, 2022; P. Kraemer et al., 2022; Tardieu, 2022). The European Union's Data Space Strategy supports organizations in pursuing data sovereignty, innovation, and competitiveness (European Commission, 2018). Data is increasingly recognized as a strategic resource for competitiveness in the digital economy and requires a new perspective on its value potential (Fassnacht et al., 2023; Hunke et al., 2022). Currently, the challenges of multilateral data sharing between organizations are significant due to trust issues and unclear benefits (Hoßbach-Zimmermann et al., 2023; Jussen, Schweihoff, Dahms, et al., 2023). Efforts are being made to promote widespread data sharing between organizations, but broad data sharing in data ecosystems remains uncommon (Bartelheimer et al., 2022; Beverungen et al., 2022; Gelhaar et al., 2023). Many organizations are unaware or do not take advantage of the new opportunities for value creation through data (Institut der deutschen Wirtschaft, 2021). Concerns about disclosing and trusting data continue to hinder the use of data spaces and prevent the realization of benefits, such as innovation, collaboration, and improved competitiveness (Bitkom, 2022). Overcoming these barriers is critical for industries and enterprises to fully leverage data spaces and realize their full potential (Gaia-X Hub Germany, 2023). Based on the scenario described above, organizations must cultivate data sovereignty as a digital competency within their organizational framework. The existing literature explored the adoption of data spaces by data-driven organizations (DDOs) but primarily outlined capabilities (Hupperz & Gieß, 2024). In this context, we aim to delineate our focus on developing actionable recommendations for data spaces.

The goal of this study is to identify a common conceptual understanding of data spaces' practical applications (Hirsch-Kreinsen et al., 2022). The paper aims to improve understanding of data spaces by recommending actions to promote data sovereignty. The researchers conducted expert interviews to gain insights and develop recommended actions for data spaces. First, data spaces and the research methodology are explained. Subsequently, the derived recommended actions are presented, and then the results are discussed along with suggestions for future research. This paper concludes by addressing the findings' implications and limitations.



## BACKGROUND INFORMATION

The term ‘sovereignty’ has been increasingly used in different forms in recent years, i.e., digital sovereignty (Glasze et al., 2023; Kagermann et al., 2021). Based on this ambiguity, the IS literature attempts to create clarity and categorize these general terms into individual areas (Hellmeier & von Scherenberg, 2023). Thus, the term ‘sovereignty’ can be differentiated in data sovereignty, digital sovereignty, technological sovereignty in order to specify their different focuses (Hellmeier & von Scherenberg, 2023). Further contributions distinguish between data sovereignty, digital sovereignty and cyber sovereignty (Hummel et al., 2021). It was found that the concept of “sovereign technology” has been insufficiently studied in the IS literature, despite its importance (Hummel et al., 2021). In contrast, cyber sovereignty has already been extensively researched in the literature (Pedreira et al., 2021), but data sovereignty as the concept of data ownership from an IS perspective has been scarce (Asswad & Marx Gómez, 2021). With the increasing importance of cross-organizational data sharing in the ecosystem, the challenges with regard to different barriers become apparent, i.e., fear of loss of control (Fassnacht et al., 2023). Unfortunately, there are many barriers to implementing data sovereignty (Hellmeier et al., 2023). Organizations in particular must develop competencies in the area of data sovereignty in order to be able to handle data in a compliant manner (Moschko et al., 2023). Other authors focus on issues of data sovereignty, including technological sovereignty (Mawere & Van Stam, 2020). Remarkably, the various concepts of sovereignty require further research (Couture & Toupin, 2019). Also, questions of sovereignty also arise in connection with the control of data spaces (Kagermann et al., 2021). Specifically, a common understanding of the term is missing (Couture & Toupin, 2019). Data Spaces are seen as a solution to data sovereignty (Hutterer & Krumay, 2022; Jarke et al., 2019), i.e., agricultural domain (Falcão et al., 2023), and digital sovereignty (Firdausy et al., 2022), as this represents a way to maintain control over one's own data resources (Nagel & Lycklama, 2021; Sarabia-Jacome et al., 2019). However, data sovereignty is influenced by technological and digital sovereignty (Hellmeier & von Scherenberg, 2023). To better understand what data sovereignty is, we use the following definition:

“Concepts of self-determination and the ability of a data provider to maintain control over its own data assets form the term data sovereignty. It is used, among other things, in the IS and SE areas to create technical solutions to protect personal and company data and depends heavily on economic, political and legal aspects.” (Hellmeier and von Scherenberg, 2023, p. 9)

Data spaces were introduced to integrate heterogeneous data sources (Franklin et al., 2005). In detail, data spaces are based on a hybrid architecture that combines schema-centralized and data-decentralized approach and enables the integration of all organizational data, regardless of format, location, or model (Halevy et al., 2006). Nowadays, data spaces are suitable for facilitating cross-organizational data sharing (Otto et al., 2019). The term “data space” is often used to describe sharing and integrating data in a federated data ecosystem (Hutterer et al., 2023). However, this term has no clear, comprehensive definition, leading to inconsistencies and ambiguities (Hutterer & Krumay, 2022). Most research focuses on the technical aspects of data spaces, but different understandings to ambiguities (Curry et al., 2022; Strnadl & Schöning, 2023). Specifically, data spaces can differ in architecture (Schleimer et al., 2023), design (Gieß et al., 2023) or components, i.e., connectors (Gieß et al., 2024). Thus, there is a need to establish a common understanding of data spaces (Hirsch-Kreinsen et al., 2022; Siska et al., 2023). The increasing demand for data as a strategic asset and the heterogeneity of data have driven the development of data management concepts (Freitas & Curry, 2016). Centralized data storage was the norm in the early years, while decentralized storage has gained prominence recently (Halevy et al., 2006). Traditional database management systems (DBMS) are limited in dealing with heterogeneous data sources and semantic integration (Freitas & Curry, 2016). In contrast, a data space management system (DSMS) is an approach that manages, retrieves, and secures data. It uses an on-demand approach that requires a low initial cost for data integration (Elsayed et al., 2006). The Data Space Support Platform (DSSP) is therefore an autonomous system that provides services without human interaction and continuously improves through a pay-as-you-go approach (Sarma et al., 2009). DSSPs realize the integration of heterogeneous data from distributed systems and provide on-demand access (Wang et al., 2016). Data spaces use an agile data integration method to identify data relationships and do not focus on data management (Guo et al., 2021). Data spaces operate without semantic integration and have no control over the data (Wang et al., 2016). The concept of data spaces is based on a decentralized approach that allows participants to share data while regulating access (Franklin et al., 2005; Otto & Jarke, 2019). The basis for the International Data Space (IDS) is the DSSP concept as a multi-sided data platform (IDSA, 2019; Otto & Jarke, 2019). The hybrid architecture of the IDS aims to establish the digital platform while leveraging trusted infrastructures to enforce data sovereignty (IDSA, 2019). In doing so, it is guided by a reference architecture proposed by the IDS Initiative (IDSA, 2022). The digital platform is an intermediary that facilitates direct data sharing between stakeholders and promotes interoperability between different data platforms (Volz et al., 2023). As depicted in Figure 1, data space architectures include elements such as a connector, a metadata broker, a vocabulary provider, an identity provider, an app store, and a clearinghouse (Drees et al., 2021; Pettenpohl et al., 2022).

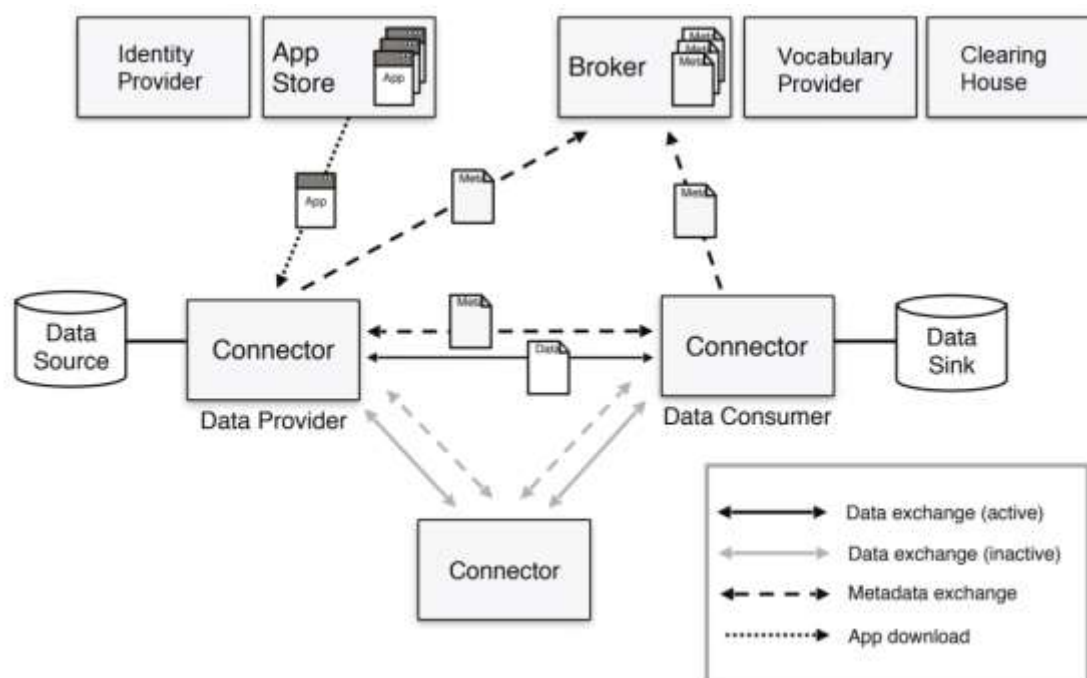

Source: (Volz et al., 2023).  
Figure 1: Data space by IDSA.

The concept of data spaces is a promising paradigm for platform-based ecosystems (Franklin et al., 2005; Hutterer & Krumay, 2022) that can connect isolated systems (Falk et al., 2021). However, issues related to data sovereignty and data sharing persist, hindering the adoption of data platforms (Jarke, 2020; Jarke et al., 2019). Establishing a federated infrastructure where individual actors agree on data-sharing guidelines is a novel strategy to address this problem (Gaia-X Hub Germany, 2022; Otto, 2022a; Siska et al., 2023). Decentralized data spaces aim to ensure the data sovereignty of organizations (Duisberg, 2022; Hutterer & Krumay, 2022; Winter et al., 2022). Many organizations face data-sharing challenges (Fassnacht et al., 2023; Heinz, Benz, et al., 2022; Kraemer et al., 2021), and a federated platform approach can increase trust and mitigate these challenges (Curry et al., 2022). The adoption of data spaces faces several challenges (Gaia-X Hub Germany, 2023), as the current literature focuses mainly on technical (Hutterer & Krumay, 2022) and capacity (Hupperz & Gieß, 2024) aspects, making broad adoption challenging (Hutterer & Krumay, 2024; Otto & Jarke, 2019). Data spaces realize a technical, legal, and economic environment for the multilateral use of data across organizational boundaries (Marko et al., 2023). There is uncertainty about the concept of data spaces and their practical implementation (Hutterer et al., 2023).

Research in this area aims to develop concrete recommendations for effectively using data spaces (Mertens et al., 2023). As mentioned, there are several data space architecture and design options (Gieß et al., 2023; Schleimer et al., 2023), such as the more centralized framework of the International Data Spaces Association (IDSA, 2022) and the more decentralized Pontus-X (Pontus-X, 2023) based on distributed ledger technology (Ocean Protocol Foundation, 2022). Currently, only a few organizations are involved in data spaces, including Catena-X (2023), Mobility Data Space (2023), and EuProGiant (2023). In addition, other initiatives are underway to create a federation of data spaces in a domain. The Manufacturing-X initiative (Plattform Industrie 4.0, 2022) is an example of an overarching industrial data space (Data Space 4.0 Alliance, 2023), while mobility data will be federated in a European Mobility Data Space (EMDS) (PrepDSpace4Mobility, 2023b).

## METHODOLOGY

This study determines recommendations for action for data spaces based on grounded theory (Glaser, 1992). Grounded theory is a scientific method in which qualitative data is analyzed to develop one's own theories based on the data. This provides a comprehensive understanding of complex social phenomena and unearths new insights. In the first step, data are divided into themes, concepts, and patterns; in the second step, categories are connected and integrated to understand their relationships. Selective coding identifies core categories that represent the emerging theory. This method is often used to study social processes, such as organizational culture, social networks, and power dynamics, and provides a careful and structured approach to qualitative data analysis. An exploratory study using a qualitative approach was conducted to take advantage of the limited knowledge available on data space implementation (Sekaran & Bougie, 2013). The authors established guidelines for a structured yet open-ended interview process and used semi-structured interviews as the primary data collection method to allow flexibility for follow-up and exploratory questions (Edwards & Holland, 2013; Lenz, 2006).

Due to the novelty and limited familiarity with the research topic, a non-probability sampling strategy was used to select respondents (Etikan et al., 2016). The goal was to find data-space experts with the necessary involvement in decision-making

processes. We chose experts (see Table 1) for their engagement in inter-organizational data sharing or projects pertaining to data spaces. These experts hailed from organizations of varying sizes, with eight from small and medium-sized enterprises (SMEs), six from mid-sized organizations, and 14 from large enterprises. Interviews continued until theoretical saturation was reached. Twenty-eight experts (E01-E28) involved in cross-organizational data space projects were initially interviewed. Interviews were conducted between October and December 2022, both in-person and online.

Table 1: Listing of experts and interview length.

Expert	Job Position	Length [min]
E01	CEO	31
E02	Head of Solution Architects	58
E03	Partner Development Manager	62
E04	Team Lead & Gaia-X Expert	35
E05	Head of the digitalisation and resilient production	51
E06	Solution Architect	113
E07	CEO	62
E08	CEO	45
E09	Senior Project Manager	45
E10	Scientific Researcher	33
E11	Data space Lead Architect	53
E12	Principal Scientist	50
E13	Principal Scientist	44
E14	Head of Data Science	44
E15	Department Lead	51
E16	Partner	49
E17	Global Head of Digitalization	34
E18	CEO	28
E19	Principal Researcher	29
E20	Senior Business Development Manager	56
E21	Director Business Chief Digital Office Industry	52
E22	Executive Partner	53
E23	Co-Founder and Business Lead	41
E24	Project Manager	42
E25	Lead Project Manager	35
E26	Deputy CTO	58
E27	Head of Digital Business	37
E28	Senior Architect/Product Manager Business Customers	38

The interviews lasted an average of 47 minutes and were conducted using Zoom during the period spanning from October to December 2022. The interviews were recorded, transcribed, and subjected to a systematic coding process rooted in the grounded theory methodology (Corbin & Strauss, 2015). One researcher executed the coding procedure. The initial coding phase involved open coding, wherein codes were generated from the raw interview data. For instance, a representative code emerged from the data, exemplified by the statement, “Organizations that were the most experimental were the most successful” (E04). Subsequently, in the axial coding phase, pre-existing codes were systematically clustered into 1st order concepts based on their shared characteristics. In the last steps the terms were aggregated forming higher-level categories. For example, the codes “Organizations that were the most experimental were the most successful” (E04) and “Create momentum to support and encourage organizations to do so” (E08) were first aggregated into the 1st order concept “creating awareness” and further aggregated to form the category labeled “Community.” Throughout the coding process, efforts were made to ensure the reliability and validity of the identified categories. We commenced our analysis by systematically examining expert statements, employing Gioia diagrams as a method for analyzing and synthesizing data (Gioia et al., 2013). Gioia diagrams, as demonstrated in studies by Kraus et al. (2022), Kujala et al. (2022) and Holzmann and Gregori (2023), are typically associated with grounded theorizing. Traditionally, they are utilized to analyze transcribed interviews and derive concepts and theories from the data (Gioia et al., 2013). As depicted in Figure 2, we employed Gioia diagrams to establish a coherent connection between expert statements and a concluding category.

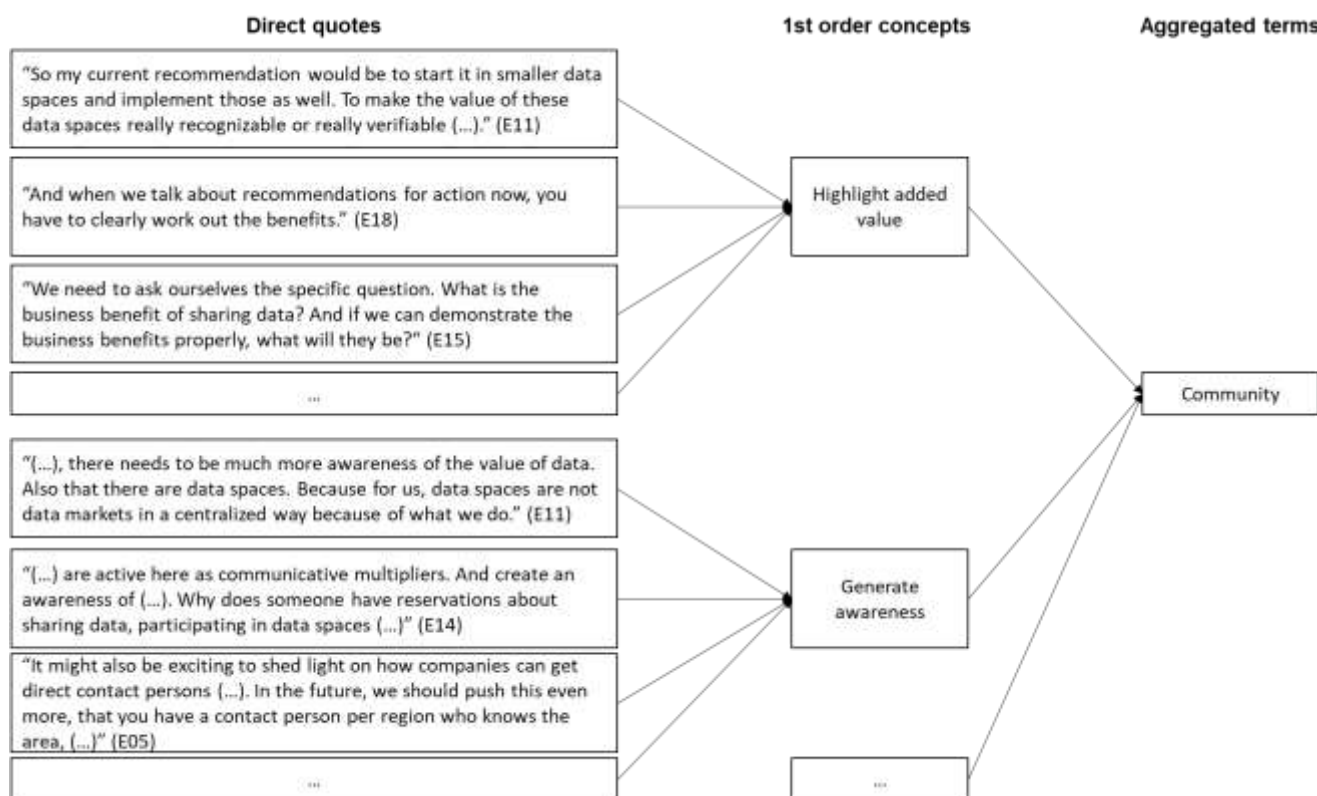

Source: (Gioia et al., 2013).

Figure 2: Illustrative visualization of the data analysis via Gioia diagram.

**RESULTS**

Based on the coding used, we derived and discussed recommended actions for four categories (community, infrastructure, interoperability, and governance). Some of the recommended actions relate to technology, others to general experiences related to cross-organizational data sharing. Interestingly, the community category (n=21) was cited most often, followed by infrastructure (n=16) and equity (n=12) for interoperability and governance. This is likely due to immature practical experience with implemented data spaces. Accordingly, a significant portion of the identified recommended actions overlap with data sharing challenges described in the literature. By combining a secure, interoperable technical infrastructure, a trusted governance framework, and a dynamic community, decentralized data sharing can thrive in data spaces. A decentralized approach to data spaces fosters trust, data sharing readiness, and collaboration while enabling secure and efficient data sharing. Ongoing technology development, community engagement, and ongoing improvement efforts should unlock the potential of data space sharing. The following recommendations for action were derived from the expert interviews and are presented in Table 2.

Table 2: Recommended actions for data spaces.

Category	Recommended action	Occurrence
Community	Promoting data spaces is to actively engage relevant stakeholders and reach a critical mass of actors.	E01, E03, E04, E05, E06, E08, E10, E11, E12, E13, E14, E17, E18, E19, E21, E22, E24, E25, E26, E27, E28
Infrastructure	Building data spaces requires establishing a trusted data infrastructure for data sharing.	E01, E04, E05, E06, E07, E09, E10, E14, E15, E16, E20, E21, E23, E24, E26, E27
Interoperability	Early connectivity between data spaces is intended to establish links to ensure interoperability.	E01, E02, E06, E07, E08, E11, E12, E15, E16, E20, E21, E28
Governance	Data spaces require appropriate governance for cross-organizational data sharing.	E01, E06, E07, E08, E11, E12, E14, E20, E21, E24, E25, E28

**Community**

The term "community" refers to a collaborative network that includes various stakeholders, including data providers, data users, organizations, and individuals. All have the goal of contributing to the development and use of data spaces. In the expert discussions, it became clear that using the network concept of a collective movement is critical to drive the proliferation of data spaces. This approach requires the active participation of all relevant stakeholders within the community throughout the collection process, with the goal of achieving a critical mass of participation. By fostering a stimulating social environment, data spaces can facilitate collaboration. For example, Expert E21 offered the following critique:

*"Digital transformation is something that every organization has already tackled to some extent. If we don't implement this digital transformation within the organization piece by piece, then the topic of the data spaces won't really work either, because*

*that is the digital transformation of an entire ecosystem. ... And I first have to lay the foundation for digital transformation within a[n] organization. And if I'm not prepared to break up existing structures piece by piece, then it will be very difficult." (E21)*

To address improvement, it is recommended to identify all potential stakeholders and gain insight into their respective roles, needs and motivations. To foster broad representation and proactively engage a critical mass of stakeholders, facilitating knowledge and resource sharing is critical, with a focus on building a foundational social ecosystem. Establishing a platform or community, i.e., an association, can promote networking and collaboration and support stakeholder participation. Stakeholders should play an active role in the design and implementation of data space initiatives, with participant exchanges serving as a means to continuously improve the community. During this process, it is critical to emphasize the added value of data spaces, as demonstrated by Expert E25 perspective.

*"That's where you could look beyond the organizational boundaries. Can you share the data in your immediate environment, find like-minded people in your ecosystem? Medium-sized organizational in particular live from the fact that they have very good customer relationships and also good relationships with suppliers. Why not sit down? And let's talk about data spaces." (E25)*

Participant experiences can be used to refine implementation strategies and improve data space dynamics. Continued assessment of stakeholders and their needs is essential to fostering an active community that engages all relevant participants in the data space implementation process, including identifying use cases. For example, existing communities, i.e., associations, may collectively decide to establish a federated data space. In particular, larger organizations may form a core group of entities that are convinced of the need for data spaces. Over time, the data space may attract more participants through network effects. Stakeholder participation can be encouraged by introducing additional incentives and rewards, such as financial support for innovative data use. Awareness initiatives, such as national data initiatives, can effectively promote data spaces by highlighting their benefits and value proposition. In addition, financial support for innovative data projects can create momentum. Organizations need direct contacts who can provide support services, such as a data space support center, to address concerns about data sharing and participation in data spaces. To alleviate these reservations, highlighting positive examples can raise awareness, as suggested by Expert E11.

*"In any case, there needs to be much more awareness of the value of data. Also that there are data spaces. Because data spaces ... are not data markets in a centralized way." (E11)*

The experts recommend greater collaboration and networking among stakeholders involved in data space creation initiatives. The collaborative approach exemplified by the Gathering movement encourages the creation of data spaces by facilitating diverse perspectives and promoting the sharing of data resources, particularly through federated data spaces. This approach ultimately culminates in the creation of data spaces that encompass a broad range of stakeholders.

### **Infrastructure**

The term "infrastructure" in this context encompasses various elements, including hardware, software, networks, services, policies and more. In addition, they all facilitate the use, storage, sharing and processing of data within and between data spaces, i.e., between interconnected systems and organizations. Expert discussions have revealed the need to create a reliable decentralized infrastructure to facilitate sovereign data sharing. In particular, with the primary goal of strengthening trust between data providers and consumers within data spaces. Trust provides the foundation for decentralized data sharing and ensures the integrity and reliability of shared data. Create data ecosystem infrastructures that support trustworthy data sharing between organizations. In addition, creating value within data spaces is a major challenge for organizations, primarily due to insufficient digital literacy. Expert E26 particularly emphasized the challenges of data integration in data spaces.

*"The organizations don't even have a handle on the data within the organization. So we're still getting to organizations where there are silos of data in the organization, let alone that you could expose or merge." (E26)*

In addition, the expert interviews resulted in the following recommendations. To improve data spaces, investments should be made in a decentralized infrastructure that includes security measures to protect data during both transmission and storage, i.e., security by design. In addition, all stakeholders should actively participate in standardization processes aimed at developing common frameworks and best practices for building a reliable infrastructure. In addition, data protection regulations and regulatory requirements should be implemented to ensure responsible data sharing. To promote trust and transparency among stakeholders, technological guidelines must be embedded in the infrastructure. In addition, prioritizing privacy and consent mechanisms will strengthen individuals' control over their data, i.e., data sovereignty. To minimize barriers to acceptance, data space services, i.e., data space connectors as a service, should be offered as soon as possible. To ensure data use complies with the law, comprehensive security measures should be taken to identify and eliminate vulnerabilities, especially to prevent data misuse.

*"The decisive factor for the success of a data space is the combination of a decentrally networked technical infrastructure with a fair organizational-legal framework, moderated by a neutral actor, and the development of a dynamic ecosystem." (E01)*

The experts also advocate starting with concrete use cases. This includes identifying and implementing practical use cases in data spaces that can demonstrate tangible benefits and build trust. The focus should be on demonstrating real-world benefits rather than relying on overly broad or complicated approaches. In this way, the potential of data spaces can be quickly grasped, and collaboration across organizational boundaries becomes more attractive. Consequently, interest in building a trusted infrastructure also increases. A trusted infrastructure involves not only sharing data within the organizational ecosystem, but also collaborating with like-minded partners. Such collaborative efforts within data spaces can yield strategic benefits and drive innovation in the evolving landscape of the data economy. As highlighted by expert E16, the establishment of data spaces should be accelerated by initiating specific use cases that are implemented at a smaller scale.

*“I believe that the point is to actually underpin the benefits that such data spaces offer as concretely as possible, i.e., to start with use cases that are as concrete as possible, which will then hopefully also be implemented somewhat faster than something generic.” (E16)*

The recommendations aim to create a secure environment that promotes a decentralized infrastructure while ensuring security, privacy, and trust. Maintaining data sovereignty, particularly control of data access, can be most effectively achieved through a decentralized infrastructure. Within a data space, participants should focus on maintaining a trusted ecosystem. Improving data integration within the organization and data spaces creates a solid foundation for decentralized data sharing. This decentralized environment fosters collaboration, encourages active engagement, and increases data transparency. Active participation in small-scale standardization processes and pilots ensures compliance with established domain requirements and legal standards. In the broader context of technological sovereignty, a trusted data infrastructure enables the establishment of data spaces for robust collaboration among stakeholders and thus data sharing.

### **Interoperability**

The term "interoperability" refers to the seamless exchange, integration and understanding of data between different systems, i.e. data spaces, participants and data. Data spaces are currently implemented as independent, self-contained stand-alone solutions. Experts have pointed out that interconnection of data spaces is important for cross-domain data spaces or a federated ecosystem, i.e., the European single market for data. Interoperability should ensure the success and effectiveness of data spaces in the data economy and increase data availability. Therefore, early networking efforts between data space initiatives from a given domain must be prioritized. In this area, fundamental challenges have been identified in terms of actively collaborating with other initiatives, promoting interoperability between data spaces, and connecting with data spaces from neighboring domains. However, there are currently several approaches to implementing data spaces. The resulting challenge of a lack of convergence through individual technological implementations is explained by Expert E12.

*“Another major topic is that there are blockchain-based approaches in this Ocean Protocol, the Gaia-X architecture, the IDS architecture, and there is an initiative or an association of organizations with the Data Space Business Alliance. They want to create a certain convergence and are working intensively on it. But as long as this convergence is going on and it’s not really clear what it’s about. For people who want to start developing, there are still a few uncertainties and risks as to which technologies or how the technologies will develop further in this large architecture. But what that looks like is not quite certain, and at the moment there are still several technology options that you can rely on. And that’s perhaps also a reason why people are still waiting.” (E12)*

During the discussions, experts emphasized the importance of promoting the interconnectedness of data spaces by ensuring their interoperability and underscored the need to actively network with other initiatives such as Gaia-X, IDS, and the Data Space Business Alliance Initiative to establish clear direction and standards within these wide-ranging architectures. Thus, it became clear that stakeholders should actively work on the convergence of decentralized blockchain-based approaches and more centralized architectures. To increase simplicity and security while avoiding vulnerabilities, they advocated for establishing simple rules that prioritize certain technologies and standards, rather than trying to integrate all options, which would accelerate the achievement of interoperability between data spaces. Collaborative efforts and common guidelines for the adoption of data space technologies were seen as a means to reduce uncertainty for organizations, enabling them to initiate projects with minimal interface complexity. The goal was to facilitate effortless communication between organizations involved in data spaces and to promote interconnectivity and compatibility within or between different domains. Central to this effort has been the essential role of standardization in data spaces, which includes the coordination of standardized interfaces and data sharing protocols. Adopting these standards would simplify interactions with different organizations in data spaces and eliminate the need to create separate, proprietary interfaces for each data space participant. Overall, standardization was seen as a means of streamlining complexity in data spaces that promotes collaboration across value chains, as emphasized by Expert E07, who highlighted the fundamental benefits of standardized connectors and services to facilitate data sharing across data spaces.

*“I have to commit to this standard once and then I don’t need 100 interfaces to any organizations. I don’t need to check 100 of my own identities with the organizations, because someone has already done that out there. I can take over and use a lot of things and don’t have to program a new crutch or do anything else to get the data there when I exchange data with every organizations.” (E07)*

In addition to the technical adaptation of the data spaces, the experts emphasized the importance of simplifying data use by establishing data standards that enable users to easily derive value from the data. This should take into account the different data formats in each area and the need for standardization and annotation across all areas. To address common challenges, strategic partnerships or networks, i.e., associations, should be used to improve data interoperability. Joint initiatives can engage stakeholders to make data work by identifying needs and aligning data standardization. Collaboration with organizations that have relevant expertise should support data format standardization and data annotation practices, i.e., for a common ontology. However, a balanced approach was recommended, emphasizing pragmatism and flexibility, and prioritizing immediate action over waiting for comprehensive standards, so that organizations can establish internal standards while leveraging proven technologies and integration services for efficiency and flexibility. Nonetheless, in promoting data convergence, the importance of standardization was emphasized to facilitate the development and widespread establishment of data standards and ultimately improve data interoperability, as expert E15 pointed out.

*“The most important things would be to promote the standardization of data, formats and the way in which data is annotated. This could be achieved through targeted support programs and by strengthening the relevant organizations that already have the know-how and could provide it, so that more data standards are developed and also used. This would be very important for the interoperability of data and data spaces.” (E15)*

Enabling connectivity between data spaces and promoting interoperability serve to prevent the isolation of data in silos, with the goal of unlocking the full potential of data sharing for stakeholders. By collaborating with other initiatives, valuable insights and synergies can be leveraged. This will improve the decision-making process for setting standards in data spaces that embrace the convergence of technologies, services, and data. Flexibility in the use of data spaces is essential to take full advantage of their benefits. Standardization that unifies and standardizes practices creates a level playing field in the data economy and promotes cross-organizational data use within data spaces.

### **Governance**

The term "governance" refers to the legal and factual regulatory framework for data spaces. Previous attempts at cross-organizational data sharing have been criticized due to problems related to interdependence and restrictive regulations (e.g., antitrust, privacy). Therefore, it is recommended that data spaces establish a consensus-based governance framework for cross-organizational data sharing. Thus, collaboration among stakeholders should be fostered through equitable and inclusive mechanisms that serve the interests of all stakeholders in neutral, federated data spaces. However, clear governance and regulations should eliminate confusion and disputes over issues such as data ownership, usage rights, and responsibilities within data spaces and build trust. Expert E28 succinctly described the challenge posed by the lack of trust among participants as follows:

*“Then, the trust position must adapt to each other. After all, these are multi-layered. So not every data space is such that every participant is equally trustworthy per se. Another complex that arises there.” (E28)*

Expert discussions have underscored the need for clear and simple rules for data sharing within data spaces. To build stakeholder trust in data spaces, it is critical to develop and implement transparent and straightforward rules for data sharing. Establishing transparent and inclusive governance mechanisms is critical to maintain data sovereignty, enable data monetization, define access rights, and ensure security, with the active participation of all stakeholders. Clear delineations of roles and responsibilities, combined with the necessary autonomy and resources, should be established to facilitate effective operations. These rules should increase the transparency of activities within data spaces and eliminate ambiguities or uncertainties that may arise from legal frameworks, such as the General Data Protection Regulation (GDPR), the EU Data Protection Act, or the German Mobility Data Act. In addition, discussions are focused on creating a streamlined governance framework for data spaces that builds trust among participants while addressing regulatory concerns to prevent excessive regulation, such as dual-use technologies or antitrust. Reducing uncertainty within data spaces should encourage the use of data across organizations. Governance should embed these principles in the infrastructure and enable participants to actively engage in standardization and regulatory processes, which is consistent with the findings of Expert E01.

*“The basis for sharing data is trust between data providers and data consumers. To achieve this, it is important, on the one hand, to anchor the prerequisites in the infrastructure and, on the other, to be actively involved in standardization and regulatory processes.” (E01)*

The need to promote a multi-layered approach to regulation and to create a governance framework that incorporates regulatory boundaries was noted. For example, intra-domain data transfer has been prevented due to antitrust concerns. Excessive regulatory oversight has hindered cross-organizational data use. In this context, data use policies, i.e., data access, data anonymization, and data privacy, need to be adjusted. Regulatory regimes, e.g., the General Data Protection Regulation (GDPR), should be based on commercially oriented guidelines to build trust in data sharing in data spaces and ensure both departments and organizations handle data responsibly and in compliance with the law. To facilitate cross-border data sharing, promoting legal interoperability is essential. Participating in data protection harmonization initiatives removes barriers and promotes seamless collaboration. Legal aspects, including data anonymization, should be included from the outset in initiatives such as GAIA-X Hubs and Data Space Support Centers to ensure that legal aspects are considered alongside technological aspects. In addition, the creation of a governance framework, particularly for initiatives such as the Digital Product Passport or the Supply Chain Act, provides clear



guidance on data sharing and collaboration and enables companies to realize the full potential of data spaces. Encouraging the development of legislation such as the EU initiatives, including the Digital Services Act, the Digital Markets Act, the Data Governance Act, the Data Act, and the AI Act, aims to promote data sharing. To address the unique challenges of dual-use goods, i.e., data in data spaces, export control regulations should be reviewed and adjusted to ensure they facilitate digital collaboration without creating unnecessary barriers. In addition, it is important to address intellectual property concerns, as noted by expert E25.

*“I think that when we talk about data spaces now, we have to take another critical look at such regulations. ... At the moment, there are already very general regulations that create many obstacles to the use of data spaces. So I think this is an important topic. The authorship of data and the intellectual property involved are also appealing. I think there are many things that need to be worked on in order to really achieve better data transparency.” (E25)*

Data space governance includes measures aimed at improving governance within data spaces to facilitate data sharing. It also addresses the legal aspects, taking into account the historical legal challenges that have hindered cross-organizational data sharing, including complex regulations such as antitrust and privacy laws that have hindered collaboration. The proposed recommendations aim to foster collaboration among stakeholders and create a neutral environment for cross-organizational data use. Further governance development should support responsible data sharing and value creation within data spaces. By implementing clear governance and regulatory provisions, potential disputes regarding data ownership, usage rights, and responsibilities can be effectively resolved, ultimately building trust in the data space ecosystem.

## DISCUSSION

Our goal was to develop recommended actions for data spaces associated with challenges. Using 28 qualitative interviews and coding techniques based on grounded theory (Glaser, 1992), we identified four categories and described recommended actions for data spaces. These findings are an important contribution to understanding this complex topic and help to promote the further development of data spaces. The challenges we identified were both technological and socio-organizational. Collaborating with existing initiatives, promoting interoperability, and establishing governance mechanisms within an infrastructure help establish a federated data space ecosystem. Prioritizing the establishment of data spaces for federated data sharing will strengthen data sovereignty for owners. Technological challenges include building a infrastructure and connecting it through interoperability. In addition, the environmental recommendations for action focus on building active communities and establishing appropriate governance mechanisms for data spaces. As data spaces are still at an early stage of development, initiatives face significant challenges (Gaia-X Hub Germany, 2023). Nonetheless, organizations are looking for opportunities to build digital competencies, i.e. data sovereignty (Moschko et al., 2023).

The environmental aspects relate in particular to challenges that have existed in connection with cross-organizational data sharing (Fassnacht et al., 2023; Gelhaar et al., 2023; Jussen et al., 2023). For example, when sharing data between organizations, tensions exist around data sovereignty and organizational and business model (Jussen et al., 2023). Specifically, there is still a lot of untapped potential in the area of business models for sharing data in data spaces (Bub, 2023). Therefore, in order to make business models successful, aspects such as trust in partners, transparency, and the desire for security must be taken into account (Schweihoff, Jussen, Dahms, et al., 2023). Regrettably, organizations are often skeptical about data sharing due to different barriers (Heinz, Park, et al., 2022). Specifically, barriers for data sharing include strategic, operational, technological, cultural, and regulatory perspectives (Fassnacht et al., 2023). Data must be shared more widely to fully realize its potential for innovation and value creation in the data economy (Winter et al., 2022). Data ownership can be strengthened by establishing appropriate governance frameworks (Gelhaar & Otto, 2020; Lee et al., 2017; Lis & Otto, 2020, 2021). Such frameworks can address concerns about data misuse and create a fair playing field for all stakeholders (Lawrenz & Rausch, 2021). Trust and legal certainty are essential to increase willingness to share and use data in a digital single market (Brost et al., 2018). The recommendation to promote a data-friendly legal framework aims to strengthen data sharing in decentralized data spaces in the data economy (Arnold et al., 2020; Fischer et al., 2023). The goal of the collection movement, which focuses on connecting actors to foster communities, i.e. ecosystems (Gelhaar et al., 2021). Specifically, to raise awareness of the value of participants data (Geisler et al., 2022; Gelhaar & Otto, 2020).

The other two recommendations for action focus on the technological aspects of data spaces (Siska et al., 2023). Establishing a trustworthy infrastructure for data sharing is of central importance (Otto, 2022a; Schleimer & Duparc, 2023). A decentralized data platform alone is insufficient to ensure responsible data governance (Torre-Bastida et al., 2022). Interestingly, specific design knowledge is required for the construction and design of data infrastructures (Schleimer & Duparc, 2023). Further, technological data space solutions must be developed to ensure this (Jarke et al., 2019). Research in data spaces was initially focused on developing solutions for integrating heterogeneous data sources (Franklin et al., 2005). However, due to the increasing importance of cross-organizational data sharing, there has been an increased focus on secure data sharing in recent years (Hutterer & Krumay, 2022). Governance has taken on greater importance in defining data spaces (Hutterer et al., 2023). A data space is seen as an opportunity for data users to make self-determined decisions about data use, which contributes to increased data transparency and the associated potential for value creation (Beverungen et al., 2022; Curry et al., 2022; Otto, 2022b). Policy initiatives in Europe are advocating for the development of a data infrastructure based on shared values and standards among stakeholders (Lewis, 2023; Minghini et al., 2022). Uniform standards and specifications must be established to attract a broad range of participants (Siska et al., 2023). The technology used must meet the requirements for trustworthy data sharing (Scerri

et al., 2020). The current challenge is to ensure data sovereignty, as existing technologies do not allow adequate control over the data once it leaves the possession of the data owner (Chowdhury et al., 2020). In this regard, the role of intermediaries for various data services becomes more important (Schweihoff, Jussen, & Möller, 2023). For this reason, it is recommended to support further data space projects testing different architectures and design options (Gieß et al., 2023; Schleimer et al., 2023). Existing data spaces (Steinbuss et al., 2023), such as the Mobility Data Space (Mobility Data Space, 2023) or Energy Data Space (Energy Data Space, 2021) take a hybrid approach, whereas HEALTH-X (HEALTH-X, 2023) is decentralized (Gieß et al., 2023). In addition, the connection of individual data spaces is necessary to prevent the formation of isolated data space silos (Abbas et al., 2022). The European Commission is committed to creating a single European market for data through initiatives such as the Data Strategy (European Commission, 2020). To this end, early networking between data spaces as a data marketplace is essential (Abbas et al., 2023). Technological solutions need to be developed to ensure interoperability between different data spaces and enable access to a wide range of data (Hemid et al., 2021). Current research initiatives are investigating the interoperable design of data spaces to form a common ecosystem (Solmaz et al., 2022). Connecting data spaces in specific areas, such as mobility (PrepDSpace4Mobility, 2023a) or industry (Data Space 4.0 Alliance, 2023; Plattform Industrie 4.0, 2022), aims to address where organizations expect to add value and increase competitiveness by participating in a data space (Marko et al., 2023).

This research provides valuable insights for various data space projects (Mertens et al., 2023; Steinbuss et al., 2023). In fact, the future of value creation lies in data-driven value networks, leading to the emergence of cooperatively operated data spaces (Plattform Industrie 4.0, 2023). The development of digital literacy is necessary to promote significant growth in the data economy (acatech – National Academy of Science and Engineering, 2023). The outlined action recommendations provide an overview of the necessary steps to establish data spaces successfully. Participants in the design of data spaces can adapt their approaches based on these recommendations for action, promoting the acceptance and adoption of data spaces. Our research helps improve the current state of knowledge about data spaces by identifying challenges, discussing recommended actions, and suggesting measures that positively influence adoption.

## CONCLUSION

The concept of data spaces is of interest in both science and business. However, there is currently a lack of comprehensive implementations in practice. We conducted qualitative interviews to gather expert perspectives and formulate recommendations for action for data spaces. The interviews resulted in several recommendations for action to progress data space adoption in four categories. Our study not only provides the basis for future initiatives but also contributes to a better understanding between researchers and organizations by identifying possible approaches and going beyond technical aspects. We thus create a basis for further research on the concept of the data space itself and the acceptance of and participation in data spaces.

The recommendations for action derived from our study provide a solid foundation for stakeholders to strengthen the use of data spaces. Although there is not yet a comprehensive body of knowledge in research on the use of data spaces, the insights gained from the expert opinions can be informative. The different recommendations for action, such as building a decentralized data infrastructure and strengthening awareness for data sharing in organizations, highlight the interdependence of these efforts. It is essential to consider the different areas of action simultaneously. The synergistic benefits offered by data spaces only occur when organizations make a cultural shift and implement strategies to improve data literacy for increased data transparency and availability. Nevertheless, data space initiatives rely on the individual needs of participants and the specific requirements of their respective domains. This requires careful consideration of the degree of autonomy and control of data space participants, considering the varying degrees of willingness to share data across and within data spaces. For perspective, regulatory requirements should encourage all participants to disclose data. For future research, it is crucial to analyze the positive aspects of value creation and innovation generation through the strategic use of data.

Despite the fundamentally sound and targeted recommendations for action discussed in this article, the experts leave numerous questions unanswered, resulting in the need for further research. Although the qualitative study presented here does not include a comprehensive survey of the experts' opinions, some of the highlighted recommendations for action are too abstract and generally formulated to be directly implemented in practice. The experts only give vague indications of suitable technical measures to effectively control and monitor data sharing within the data space without taking legal requirements into account. The calls for more organizational action raise the question of how to meet the demands for increased data transparency and expanded datasets. Due to increasing competition, each organization must decide how to achieve these goals to succeed in the global data economy. Data spaces offer a path to achieving data sovereignty while empowering digital literacy. Consequently, interesting research questions remain open in the field of data spaces, from which valuable and concrete recommendations for action can be derived for corporate practice. In addition to the question of the interactions between data sovereignty and data transparency, further research should examine the opportunities and risks of new technologies.

## REFERENCES

- Abbas, A. E., Ofe, H., Zuiderwijk, A., & De Reuver, M. (2022). Preparing Future Business Data Sharing via a Meta-Platform for Data Marketplaces: Exploring Antecedents and Consequences of Data Sovereignty. *35 Th Bled eConference Digital Restructuring and Human (Re)Action*, 571–586. <https://doi.org/10.18690/um.fov.4.2022.36>
- Abbas, A. E., Ofe, H., Zuiderwijk, A., & De Reuver, M. (2023). Toward Business Models for a Meta-Platform: Exploring Value Creation in the Case of Data Marketplaces. *Proceedings of the 56th Hawaii International Conference on System Sciences*. <https://hdl.handle.net/10125/103086>

- acatech – National Academy of Science and Engineering. (2023). *National Initiative for AI-based Transformation to the Data Economy*. <https://en.acatech.de/project/national-initiative-data-economy/>
- Arnold, R., Hildebrandt, C., & Taş, S. (2020). *European Data Economy: Between Competition and Regulation* (Study Series 251538). WIK Wissenschaftliches Institut für Infrastruktur und Kommunikationsdienste GmbH. [https://www.wik.org/fileadmin/Studien/2021/European\\_Data\\_Economy.pdf](https://www.wik.org/fileadmin/Studien/2021/European_Data_Economy.pdf)
- Asswad, J., & Marx Gómez, J. (2021). Data Ownership: A Survey. *Information*, 12(11), 465. <https://doi.org/10.3390/info12110465>
- Beverungen, D., Hess, T., Köster, A., & Lehrer, C. (2022). From private digital platforms to public data spaces: Implications for the digital transformation. *Electronic Markets*, 32(2), 493–501.
- Brost, G. S., Huber, M., Weiß, M., Protsenko, M., Schütte, J., & Wessel, S. (2018). An ecosystem and iot device architecture for building trust in the industrial data space. *Proceedings of the 4th ACM Workshop on Cyber-Physical System Security*, 39–50.
- Bub, U. (2023). „Ein klares Geschäftsmodell für das Teilen von Daten in Data Spaces hat sich noch nicht herauskristallisiert“. *Wirtschaftsinformatik & Management*, 15(3), 191–193. <https://doi.org/10.1365/s35764-023-00483-1>
- Catena-X. (2023). *Catena-X General Presentation*. [https://catena-x.net/fileadmin/user\\_upload/Vereinsdokumente/Catena-X\\_general\\_presentation.pdf](https://catena-x.net/fileadmin/user_upload/Vereinsdokumente/Catena-X_general_presentation.pdf)
- Chowdhury, M. J. M., Kayes, A. S. M., Watters, P., Scolyer-Gray, P., & Ng, A. (2020). *Patient Controlled, Privacy Preserving IoT Healthcare Data Sharing Framework*. Hawaii International Conference on System Sciences. <https://doi.org/10.24251/HICSS.2020.453>
- Corbin, J. M., & Strauss, A. L. (2015). *Basics of qualitative research: Techniques and procedures for developing grounded theory* (Fourth edition). SAGE.
- Couture, S., & Toupin, S. (2019). What does the notion of “sovereignty” mean when referring to the digital? *New Media & Society*, 21(10), 2305–2322. <https://doi.org/10.1177/1461444819865984>
- Curry, E., Scerri, S., & Tuikka, T. (2022). *Data Spaces: Design, Deployment and Future Directions*. Springer Nature.
- Data Space 4.0 Alliance. (2023). *Data Space 4.0*. <https://manufacturingdataspace-csa.eu/>
- Drees, H., Kubitz, D. O., Lipp, J., Pretzsch, S., & Langdon, C. S. (2021). *Mobility Data Space – First Implementation and Business Opportunities*. 27th ITS World Congress, Hamburg.
- Duisberg, A. (2022). Legal Aspects of IDS: Data Sovereignty—What Does It Imply? *Designing Data Spaces*, 61.
- Edwards, R., & Holland, J. (2013). *What is qualitative interviewing?* Bloomsbury.
- Elsayed, I., Brezany, P., & Tjoa, A. M. (2006). Towards Realization of Dataspaces. *17th International Conference on Database and Expert Systems Applications (DEXA '06)*, 266–272. <https://doi.org/10.1109/DEXA.2006.140>
- Energy Data Space. (2021). *EnDaSpace—Moderne Datenökonomie in der Energiewirtschaft*. <https://www.iee.fraunhofer.de/de/projekte/suche/2021/endaspace.html>
- Etikan, I., Musa, S. A., Alkassim, R. S., & others. (2016). Comparison of convenience sampling and purposive sampling. *American Journal of Theoretical and Applied Statistics*, 5(1).
- EuProGigant. (2023). *EDGE COMPUTING IN THE EUPROGIGANT PROJECT*. [https://euprogigant.com/wp-content/uploads/2022/03/EuProGigant-Whitepaper\\_EN.pdf](https://euprogigant.com/wp-content/uploads/2022/03/EuProGigant-Whitepaper_EN.pdf)
- European Commission. (2020). *A European strategy for data*. <https://eur-lex.europa.eu/legal-content/EN/TXT/PDF/?uri=CELEX:52020DC0066&from=EN>
- Falcão, R., Matar, R., Rauch, B., Elberzhager, F., & Koch, M. (2023). A Reference Architecture for Enabling Interoperability and Data Sovereignty in the Agricultural Data Space. *Information*, 14(3), 197. <https://doi.org/10.3390/info14030197>
- Falk, S., Guggenberger, T., Lehmann-Brauns, S., Leyh, C., Matischok, L., & Otto, B. (2021). *Digitale Ökosysteme in der Industrie – Typologie, Beispiele und zukünftige Entwicklung*. Plattform Industrie 4.0. [https://www.plattform-i40.de/IP/Redaktion/DE/Downloads/Publikation/Digitale\\_Oekosysteme.pdf?\\_\\_blob=publicationFile&v=1](https://www.plattform-i40.de/IP/Redaktion/DE/Downloads/Publikation/Digitale_Oekosysteme.pdf?__blob=publicationFile&v=1)
- Fassnacht, M., Benz, C., Heinz, D., Leimstoll, J., & Satzger, G. (2023). Barriers to Data Sharing among Private Sector Organizations. *Proceedings of the 56th Hawaii International Conference on System Sciences*. Hawaii International Conference on Systems Sciences (HICSS). <https://hdl.handle.net/10125/103084>
- Firdausy, D. R., De Alencar Silva, P., Van Sinderen, M., & Iacob, M.-E. (2022). Towards a Reference Enterprise Architecture to enforce Digital Sovereignty in International Data Spaces. *2022 IEEE 24th Conference on Business Informatics (CBI)*, 117–125. <https://doi.org/10.1109/CBI54897.2022.00020>
- Fischer, B., Duisberg, A., Busche, A., Busch, M., Haas, P., & Pappas, C. (2023). *Regulatory trends regarding the data economy and industrie 4.0*. Plattform Industrie 4.0. [https://www.plattform-i40.de/IP/Redaktion/EN/Downloads/Publikation/AG4\\_regulatory-trends.pdf?\\_\\_blob=publicationFile&v=1](https://www.plattform-i40.de/IP/Redaktion/EN/Downloads/Publikation/AG4_regulatory-trends.pdf?__blob=publicationFile&v=1)
- Franklin, M., Halevy, A., & Maier, D. (2005). From databases to dataspace: A new abstraction for information management. *ACM SIGMOD Record*, 34(4), Article 4. <https://doi.org/10.1145/1107499.1107502>
- Freitas, A., & Curry, E. (2016). Big Data Curation. In J. M. Cavanillas, E. Curry, & W. Wahlster (Eds.), *New Horizons for a Data-Driven Economy* (pp. 87–118). Springer International Publishing. [https://doi.org/10.1007/978-3-319-21569-3\\_6](https://doi.org/10.1007/978-3-319-21569-3_6)
- Gaia-X Hub Germany. (2022). *Was ist ein Datenraum?* Gaia-X Hub Deutschland c/o acatech – Deutsche Akademie der Technikwissenschaften. [https://gaia-x-hub.de/wp-content/uploads/2022/10/20220914\\_White\\_Paper\\_22.1\\_Definition\\_Datenraum\\_final.pdf](https://gaia-x-hub.de/wp-content/uploads/2022/10/20220914_White_Paper_22.1_Definition_Datenraum_final.pdf)
- Gaia-X Hub Germany. (2023). *Herausforderungen und Lösungsansätze der Gaia-X Förderprojekte*. Gaia-X Hub Deutschland c/o acatech – Deutsche Akademie der Technikwissenschaften. <https://gaia-x-hub.de/wp-content/uploads/2023/04/WP-Stand-Foerdervorhaben-Gaia-X.pdf>

- Geisler, S., Vidal, M.-E., Cappiello, C., Lóscio, B. F., Gal, A., Jarke, M., Lenzerini, M., Missier, P., Otto, B., Paja, E., Pernici, B., & Rehof, J. (2022). Knowledge-Driven Data Ecosystems Toward Data Transparency. *Journal of Data and Information Quality*, 14(1), 1–12. <https://doi.org/10.1145/3467022>
- Gelhaar, J., Both, J., & Otto, B. (2021). *Requirements For Incentive Mechanisms In Industrial Data Ecosystems*. <https://doi.org/10.15488/11267>
- Gelhaar, J., Müller, P., Bergmann, N., & Dogan, R. (2023). Motives and incentives for data sharing in industrial data ecosystems: An explorative single case study. *Proceedings of the 56th Hawaii International Conference on System Sciences (HICSS)*. Hawaii International Conference on System Sciences (HICSS), Hawaii, USA. <https://hdl.handle.net/10125/103085>
- Gelhaar, J., & Otto, B. (2020). Challenges in the Emergence of Data Ecosystems. *Pacific Asia Conference on Information Systems (PACIS)*, 175.
- Gieß, A., Hupperz, M., Schoormann, T., & Möller, F. (2024). *What Does it Take to Connect? Unveiling Characteristics of Data Space Connectors*. Hawaii International Conference on System Sciences (HICSS).
- Gieß, A., Möller, F., Schoormann, T., & Otto, B. (2023). *Design options for data spaces*. Thirty-first European Conference on Information Systems (ECIS 2023).
- Gioia, D. A., Corley, K. G., & Hamilton, A. L. (2013). Seeking Qualitative Rigor in Inductive Research: Notes on the Gioia Methodology. *Organizational Research Methods*, 16(1), 15–31. <https://doi.org/10.1177/1094428112452151>
- Glaser, B. G. (1992). *Basics of grounded theory analysis*. Sociology Press.
- Glasze, G., Cattaruzza, A., Douzet, F., Dammann, F., Bertran, M.-G., Bômont, C., Braun, M., Danet, D., Desforges, A., Géry, A., Grumbach, S., Hummel, P., Limonier, K., Münßinger, M., Nicolai, F., Pétiñaud, L., Winkler, J., & Zanin, C. (2023). Contested Spatialities of Digital Sovereignty. *Geopolitics*, 28(2), 919–958. <https://doi.org/10.1080/14650045.2022.2050070>
- Guo, J., Cheng, Y., Wang, D., Tao, F., & Pickl, S. (2021). Industrial Dataspace for smart manufacturing: Connotation, key technologies, and framework. *International Journal of Production Research*, 1–16. <https://doi.org/10.1080/00207543.2021.1955996>
- Halevy, A., Franklin, M., & Maier, D. (2006). Principles of dataspace systems. *Proceedings of the Twenty-Fifth ACM SIGMOD-SIGACT-SIGART Symposium on Principles of Database Systems*.
- HEALTH-X. (2023). *HEALTH-X dataLOFT*. <https://www.health-x.org/home>
- Heinz, D., Benz, C., Fassnacht, M., & Satzger, G. (2022). Past, Present and Future of Data Ecosystems Research: A Systematic Literature Review. *Pacific Asia Conference on Information Systems (PACIS)*.
- Heinz, D., Park, H.-R., Benz, C., & Satzger, G. (2022). Innovating Smart Product-Service Systems in Manufacturing SMEs: Current Practices, Affordances, and Constraints. *2022 IEEE 24th Conference on Business Informatics (CBI)*, 33–40. <https://doi.org/10.1109/CBI54897.2022.10046>
- Hellmeier, M., Pampus, J., Qarawlus, H., & Howar, F. (2023). Implementing Data Sovereignty: Requirements & Challenges from Practice. *Proceedings of the 18th International Conference on Availability, Reliability and Security*, 1–9. <https://doi.org/10.1145/3600160.3604995>
- Hellmeier, M., & von Scherenberg, F. (2023). *A delimitation of data sovereignty from digital and technological sovereignty*. Thirty-first European Conference on Information Systems (ECIS 2023).
- Hemid, A., Arnon, O., Gindl, S., Barnett, A., & Mireles-Chavez, V. (2021). *TRUSTS Technology—Equipping European Data Markets with Technological Innovations*. Trusted Secure Data Sharing Space. [https://www.trusts-data.eu/wp-content/uploads/2021/06/TRUSTS\\_Whitepaper\\_Technology\\_vfff\\_30062021-1.pdf](https://www.trusts-data.eu/wp-content/uploads/2021/06/TRUSTS_Whitepaper_Technology_vfff_30062021-1.pdf)
- Hirsch-Kreinsen, H., Kubach, U., Stark, R., von Wichert, G., Litsche, S., Sedlmeier, J., & Steglich, S. (2022). *Themenfelder Industrie 4.0: Forschungs-und Entwicklungsbedarfe zur erfolgreichen Umsetzung von Industrie 4.0 (2)*. Forschungsbeirat der Plattform Industrie 4.0/acatech – Deutsche Akademie der Technikwissenschaften.
- Holzmann, P., & Gregori, P. (2023). The promise of digital technologies for sustainable entrepreneurship: A systematic literature review and research agenda. *International Journal of Information Management*, 68, 102593. <https://doi.org/10.1016/j.ijinfomgt.2022.102593>
- Hummel, P., Braun, M., Tretter, M., & Dabrock, P. (2021). Data sovereignty: A review. *Big Data & Society*, 8(1), 205395172098201. <https://doi.org/10.1177/2053951720982012>
- Hupperz, M., & Gieß, A. (2024). *The Interplay of Data-Driven Organizations and Data Spaces: Unlocking Capabilities for Transforming Organizations in the Era of Data Spaces*. Hawaii International Conference on System Sciences (HICSS).
- Hutterer, A., & Krumay, B. (2022). Integrating Heterogeneous Data in Dataspaces—A Systematic Mapping Study. *PACIS 2022 Proceedings*. Pacific Asia Conference on Information Systems (PACIS). <https://aisel.aisnet.org/pacis2022/222>
- Hutterer, A., & Krumay, B. (2024). *The adoption of data spaces: Drivers toward federated data sharing*. Hawaii International Conference on System Sciences (HICSS).
- Hutterer, A., Krumay, B., & Mühlburger, M. (2023). What Constitutes a Data space? Conceptual Clarity beyond Technical Aspects. *29th Americas Conference on Information Systems (AMCIS)*. Americas Conference on Information Systems (AMCIS), Panama. [https://aisel.aisnet.org/amcis2023/eco\\_systems/eco\\_systems/5](https://aisel.aisnet.org/amcis2023/eco_systems/eco_systems/5)
- IDSA. (2019). *IDS – A standard for data sovereignty and indispensable element of data ecosystems*. International Data Space Association. <https://internationaldataspaces.org/wp-content/uploads/IDSA-Brochure-IDS-Standard-for-Data-Sovereignty-Indispensable-Element-for-Data-Ecosystems.pdf>
- IDSA. (2022). *Reference Architecture Model, Version 4.0*. <https://docs.internationaldataspaces.org/ids-ram-4/>
- Jarke, M. (2020). Data sovereignty and the internet of production. *International Conference on Advanced Information Systems Engineering*, 549–558.

- Jarke, M., Otto, B., & Ram, S. (2019). Data sovereignty and data space ecosystems. In *Business & Information Systems Engineering* (Vol. 61, Issue 5, pp. 549–550). Springer.
- Jussen, I., Schweihoff, J., & Möller, F. (2023). Tensions in Inter-Organizational Data Sharing: Findings from Literature and Practice. 2023 *IEEE 25th Conference on Business Informatics (CBI)*, 1–10. <https://doi.org/10.1109/CBI58679.2023.10187530>
- Kagermann, H., Streibich, K.-H., & Suder, K. (2021). *Digital Sovereignty Status Quo and Perspectives*. acatech – National Academy of Science and Engineering.
- Kraemer, J., Stüdle, N., & Zierke, O. (2021). Data as a Public Good: Experimental Insights on the Optimal Design of B2B Data Sharing Platforms. *SSRN Electronic Journal*. <https://doi.org/10.2139/ssrn.3970821>
- Kraus, S., Breier, M., Lim, W. M., Dabić, M., Kumar, S., Kanbach, D., Mukherjee, D., Corvello, V., Piñeiro-Chousa, J., Liguori, E., Palacios-Marqués, D., Schiavone, F., Ferraris, A., Fernandes, C., & Ferreira, J. J. (2022). Literature reviews as independent studies: Guidelines for academic practice. *Review of Managerial Science*, 16(8), 2577–2595. <https://doi.org/10.1007/s11846-022-00588-8>
- Kujala, J., Sachs, S., Leinonen, H., Heikkinen, A., & Laude, D. (2022). Stakeholder Engagement: Past, Present, and Future. *Business & Society*, 61(5), 1136–1196. <https://doi.org/10.1177/00076503211066595>
- Lawrenz, S., & Rausch, A. (2021). *Don't Buy A Pig In A Poke A Framework for Checking Consumer Requirements In A Data Marketplace*. Hawaii International Conference on System Sciences. <https://doi.org/10.24251/HICSS.2021.566>
- Lee, S. U., Zhu, L., & Jeffery, R. (2017). Data governance for platform ecosystems: Critical factors and the state of practice. *arXiv Preprint arXiv:1705.03509*.
- Lenz, K. (2006). Methoden der empirischen Sozialforschung III. Komplex: Qualitative Forschungsmethoden. *Aufgerufen Am*, 21, 2017.
- Lewis, J. A. (2023). *An Overview of Global Cloud Competition*. Center for Strategic and International Studies. [https://csis-website-prod.s3.amazonaws.com/s3fs-public/2023-04/230410\\_Lewis\\_Overview\\_Cloud\\_1.pdf?VersionId=6AadFmPzIuwPiLPNrlqX.sqwOZYnPOu0](https://csis-website-prod.s3.amazonaws.com/s3fs-public/2023-04/230410_Lewis_Overview_Cloud_1.pdf?VersionId=6AadFmPzIuwPiLPNrlqX.sqwOZYnPOu0)
- Lis, D., & Otto, B. (2020). Data Governance in Data Ecosystems—Insights from Organizations. *AMCIS 2020 Proceedings. 12*. [https://aisel.aisnet.org/amcis2020/strategic\\_uses\\_it/strategic\\_uses\\_it/12](https://aisel.aisnet.org/amcis2020/strategic_uses_it/strategic_uses_it/12)
- Lis, D., & Otto, B. (2021). Towards a Taxonomy of Ecosystem Data Governance. *Proceedings of the 54th Hawaii International Conference on System Sciences*. Hawaii International Conference on System Sciences. <https://doi.org/10.24251/HICSS.2021.733>
- Marko, A., Plass, C., Kuttner, D., Laß, D., Bashiri, E., Barnstedt, E., Piller, F., Heinrich, H., Gayko, J., Wirth, J., Görlitz, J., Hoffman, M. W., Wittek, N., Madeja, N., de Beauregard, P., Kiradjiev, P., Müller, S. K., Lehmann-Brauns, S., Falk, S., ... von Diemar, U. (2023). *Industrial Metaverse*. Plattform Industrie 4.0. [https://www.plattform-i40.de/IP/Redaktion/DE/Downloads/Publikation/Industrial\\_Metaverse.pdf?\\_\\_blob=publicationFile&v=5](https://www.plattform-i40.de/IP/Redaktion/DE/Downloads/Publikation/Industrial_Metaverse.pdf?__blob=publicationFile&v=5)
- Mawere, M., & Van Stam, G. (2020). Data Sovereignty: A Perspective From Zimbabwe. *12th ACM Conference on Web Science Companion*, 13–19. <https://doi.org/10.1145/3394332.3402823>
- Mertens, C., Giussani, G., & González, C. (2023). *The Data Spaces Radar* (2.0). International Data Spaces Association. <https://doi.org/10.5281/ZENODO.8059216>
- Minghini, M., Kotsev, A., & Granell, C. (2022). A European Approach to the Establishment of Data Spaces. *Data*, 7(8), 118. <https://doi.org/10.3390/data7080118>
- Mobility Data Space. (2023). *The Data Sharing Community*. <https://mobility-dataspace.eu/>
- Moschko, L., Blazevic, V., & Piller, F. T. (2023). Data Sovereignty as Organisational Competence for Digital Innovation in Industrial Incumbents. *Academy of Management Proceedings*, 2023(1), 19081. <https://doi.org/10.5465/AMPROC.2023.19081abstract>
- Nagel, L., & Lycklama, D. (2021). *Design Principles for Data Spaces—Position Paper* (1.0). Zenodo. <https://doi.org/10.5281/ZENODO.5105744>
- Ocean Protocol Foundation. (2022). *Ocean Protocol: Tools for the Web3 Data Economy*. Ocean Protocol Foundation. <https://oceanprotocol.com/tech-whitepaper.pdf>
- Otto, B. (2022a). A federated infrastructure for European data spaces. *Communications of the ACM*, 65(4), 44–45. <https://doi.org/10.1145/3512341>
- Otto, B. (2022b). The evolution of data spaces. In *Designing Data Spaces: The Ecosystem Approach to Competitive Advantage* (pp. 3–15). Springer International Publishing Cham.
- Otto, B., & Jarke, M. (2019). Designing a multi-sided data platform: Findings from the International Data Spaces case. *Electronic Markets*, 29(4), Article 4.
- Pedreira, V., Barros, D., & Pinto, P. (2021). A Review of Attacks, Vulnerabilities, and Defenses in Industry 4.0 with New Challenges on Data Sovereignty Ahead. *Sensors*, 21(15), 5189. <https://doi.org/10.3390/s21155189>
- Pettenpohl, H., Spiekermann, M., & Both, J. R. (2022). International data spaces in a nutshell. *Designing Data Spaces; Springer: Cham, Switzerland*, 29–40.
- Plattform Industrie 4.0. (2022). *Manufacturing-X*. Bundesministerium für Wirtschaft und Klimaschutz (BMWK). [https://www.plattform-i40.de/IP/Redaktion/DE/Downloads/Publikation/Manufacturing-X\\_lang.pdf?\\_\\_blob=publicationFile&v=1](https://www.plattform-i40.de/IP/Redaktion/DE/Downloads/Publikation/Manufacturing-X_lang.pdf?__blob=publicationFile&v=1)
- Plattform Industrie 4.0. (2023). *Industrie 4.0: Auf dem Weg zur intelligent vernetzten Industrie*. [https://www.plattform-i40.de/IP/Redaktion/DE/Downloads/Publikation/2023-fortschrittsbericht.pdf?\\_\\_blob=publicationFile&v=6](https://www.plattform-i40.de/IP/Redaktion/DE/Downloads/Publikation/2023-fortschrittsbericht.pdf?__blob=publicationFile&v=6)
- Pontus-X. (2023). *Pontus-X Documentation*. <https://docs.genx.minimal-gaia-x.eu/docs/intro>

- PrepDSpace4Mobility. (2023a). *Laying the foundation for a common European mobility data space*. <https://mobilitydataspace-csa.eu/>
- PrepDSpace4Mobility. (2023b). *Preparatory action to establish a common European data space for mobility*. <https://mobilitydataspace-csa.eu/wp-content/uploads/2023/07/psf-27-june.pdf>
- Sarabia-Jacome, D., Lacalle, I., Palau, C. E., & Esteve, M. (2019). Enabling Industrial Data Space Architecture for Seaport Scenario. *2019 IEEE 5th World Forum on Internet of Things (WF-IoT)*, 101–106. <https://doi.org/10.1109/WF-IoT.2019.8767216>
- Sarma, A. D., Dong, X. L., & Halevy, A. Y. (2009). Data modeling in dataspace support platforms. In *Conceptual Modeling: Foundations and Applications* (pp. 122–138). Springer.
- Scerri, S., Tuikka, T., & Lopez de Vallejoan, I. (2020). *Towards a European-Governed Data Sharing Space*. Big Data Value Association. [https://www.bdva.eu/sites/default/files/BDVA%20DataSharingSpaces%20PositionPaper%20V2\\_2020\\_Final.pdf](https://www.bdva.eu/sites/default/files/BDVA%20DataSharingSpaces%20PositionPaper%20V2_2020_Final.pdf)
- Schleimer, A. M., & Duparc, E. (2023). Designing Digital Infrastructures for Industrial Data Ecosystems -A Literature Review. *Proceedings of the 18th International Conference on Wirtschaftsinformatik*. International Conference on Wirtschaftsinformatik, Paderborn. <https://aisel.aisnet.org/wi2023/32>
- Schleimer, A. M., Fraunhofer, I., Jahnke, N., & Otto, B. (2023). Architecture Design Options for Federated Data Spaces. *Proceedings of the 56th Hawaii International Conference on System Sciences*. Hawaii International Conference on System Sciences (HICCS). <https://hdl.handle.net/10125/103078>
- Schweihoff, J. C., Jussen, I., Dahms, V., Möller, F., & Otto, B. (2023). How to Share Data Online (fast) – A Taxonomy of Data Sharing Business Models. *Proceedings of the 56th Hawaii International Conference on System Sciences*. Hawaii International Conference on System Sciences (HICSS). <https://hdl.handle.net/10125/102706>
- Schweihoff, J. C., Jussen, I., & Möller, F. (2023). Trust me, I'm an Intermediary! Exploring Data Intermediation Services. *Proceedings of the 18th International Conference on Wirtschaftsinformatik*. International Conference on Wirtschaftsinformatik. <https://aisel.aisnet.org/wi2023/23>
- Sekaran, U., & Bougie, R. (2013). *Research methods for business: A skill-building approach* (6th ed). Wiley & Sons.
- Siska, V., Karagiannis, V., & Drobnic, M. (2023). *Building a Dataspace: Technical Overview*. Gaia-X Hub Austria. <https://www.gaia-x.at/wp-content/uploads/2023/04/WhitepaperGaiaX.pdf>
- Solmaz, G., Cirillo, F., Fürst, J., Jacobs, T., Bauer, M., Kovacs, E., Santana, J. R., & Sánchez, L. (2022). Enabling data spaces: Existing developments and challenges. *Proceedings of the 1st International Workshop on Data Economy*, 42–48. <https://doi.org/10.1145/3565011.3569058>
- Steinbuss, S., de Roode, M., Papakosta, S., Klinker, P., Punter, M., & Jimenez, S. (2023). *Data Spaces Landscape – Overview and relations of data spaces initiatives, standards, and tools (1.0)*.
- Strnadl, C., & Schöning, H. (2023). Data platforms, Data Spaces, and (Data-)Ecosystems [Manuscript in preparation]. In *Data Governance*. Weber (Ed.); Springer.
- Torre-Bastida, A. I., Gil, G., Miñón, R., & Díaz-de-Arcaya, J. (2022). Technological Perspective of Data Governance in Data Space Ecosystems. In *Data Spaces: Design, Deployment and Future Directions* (pp. 65–87). Springer International Publishing Cham.
- Volz, F., Sutschet, G., Stojanovic, L., & Usländer, T. (2023). On the Role of Digital Twins in Data Spaces. *Sensors*, 23(17), 7601. <https://doi.org/10.3390/s23177601>
- Wang, Y., Song, S., & Chen, L. (2016). A survey on accessing dataspace. *ACM SIGMOD Record*, 45(2), 33–44.
- Winter, J., Frey, A., & Biehler, J. (2022). Towards the Next Decade of Industrie 4.0 – Current State in Research and Adoption and Promising Development Paths from a German Perspective. *Sci*, 4(3), 31. <https://doi.org/10.3390/sci4030031>

## Investigating Influencing Factors of Consumer Purchase in Airport Shopping Mall: A Mixed Methods Study

Qiongwei Ye <sup>1</sup>  
Danni Zhang <sup>2</sup>  
Yumei Luo <sup>3,\*</sup>

\*Corresponding author

<sup>1</sup> Professor, Business School, Yunnan University of Finance and Economics, China. yeqiongwei@163.com

<sup>2</sup> Business School, Yunnan University of Finance and Economics, China. 2601893144@qq.com

<sup>3</sup> Business and Tourism Management, Yunnan University, China, luoyumei@ynu.edu.cn

### ABSTRACT

This study focuses on the influencing factors of consumers' purchasing decisions in airport shopping malls. Firstly, based on the grounded theory method, the semi-structured interview and the online review data are encoded, and the EKB model is used to construct the influencing factors of consumers' purchasing decision-making, including eWOM, perceived risk, perceived quality, perceived price, situational factors and shopping values. Finally, the structural model is analyzed by using the sample data of 360 airport consumers. The results show that these constructs have significant impact on consumers' purchasing decisions, and perceived risk and perceived price have negative impacts on purchasing decisions.

*Keywords:* eWOM, purchasing decisions, airport shopping mall, EKB model, mixed methods.

### INTRODUCTION

With the rapid development of economic, shopping centers have become more and more popular in modern cities. These shopping centers are not only places for business transactions, but also a complex of multiple functions such as consumption, entertainment and social interaction. According to the report on the Contribution of Chinese Shopping Centers to Economic and Social Development (2021) released by the China Chain Operation Association (CCOA), as of 2021, there are more than 6,000 shopping centers in China, with the total business volume accounting for 10.7% of the total national retail sales in the same period (<https://cj.sina.com.cn/articles/view/1644114654/61ff32de020011fr0>). Shopping malls in China are developing rapidly and playing an increasingly important role in consumers' lives. Shopping malls are a collection of functional appeals, emotional appeal, and value appeal. Consumers' leisure shopping is an experiential interactive activity, aiming to seek pleasant experience and sensory stimulation (Krey, Picot-Coupey, Cliquet, & Services, 2022). Shopping malls are favored by consumers in the form of comprehensive and diversified experience. However, due to the increase in the number of shopping malls and the serious homogenization, at the same time, with the vigorous development of e-commerce, online shopping and other online retail formats continue to emerge, and the retail market competition is becoming increasingly fierce, resulting in the urgent need for optimization and upgrading of shopping malls (Calvo-Porrá & Lévy-Mangin, 2019).

In recent years, the concept of building an airport shopping center has received attention from all walks of life. For example, since its operation in 2019, Beijing Daxing International Airport has adhered to the service purpose of "people's aviation for the people", innovated service and management practices, and built an international benchmark smart airport. Smart airport is the future development trend of airports, aiming to use the Internet, cloud computing and other technologies to closely integrate airport resources, which will benefit stakeholders including passengers to provide new services for their consumers (Svitek, Řehoř, Vittek, & Dvořáková, 2021). For non-aviation services (e.g., VIP lounge services, baggage services, catering services, leisure and entertainment and other ground services), the shopping mall model is used to operate, which has become an important profit channel for airports. Therefore, in the context of airport shopping centers, how to take the opportunity of "last hour" to promote consumers' purchase, maximize the spillover of business value and increase the value of resources, has become an urgent problem to be solved.

EKB model, also known as Engel model, is widely used in the study of consumer behavior. It believes that consumer behavior consists of five stages, namely problem identification, information search, evaluation and choice, purchase and post-purchase emotion. The purchasing decision process embodied in the EKB model is influenced by the environment and personal characteristics (Park & Cho, 2012). Therefore, this study will be mainly based on EKB model to identify the key factors affecting passenger purchase decision and construct a theoretical model.

Online reviews are the main reference information for consumers when making purchase decisions. Consumers often browse online review data before making purchase decisions. Positive online review will increase consumer confidence and promote them to make purchase decisions. Negative online reviews can make consumers wonder about the product, discouraging their



purchasing decisions (Cheung & Thadani, 2012). The source credibility and perceived quantity of online reviews have significant impacts on purchase intention (Zhang, Zhao, Cheung, & Lee, 2014). Online reviews could be a good source of information to identify the key factors affecting passengers' purchasing decisions.

### LITERATURE REVIEWS

Shopping malls have gradually evolved from traditional physical retail to functional, entertainment and value. Consumers are now more inclined to experiential shopping, and purchasing decision-making behaviors show a diversified and personalized development trend. Ko, Roberts, and Cho (2006) found that different cultural backgrounds have an impact on consumers' shopping and interactive motivation. Alavi, Rezaei, Valaei, and Wan Ismail (2015) demonstrated a positive correlation between satisfaction and shopping intention. When shopping in malls, consumers with hedonic shopping style show high degree of habitual, brand consciousness and fashion consciousness. Leisure conscious consumers have lower satisfaction and purchase intention while novelty and fashion-conscious consumers have lower level of satisfaction, but do not show lower purchase intention. Based on SOR model, Sharma, Mohan, and Gupta (2022) demonstrated the significant impact of store layout and functional value on consumers' repurchasing intention. Wei Khong and Sim Ong (2014) adopted systematic random sampling method and a series of multivariate technology to investigate consumers loyalty in shopping malls in Malaysia, and explored the relationship between brand trust and loyalty. Ylilehto, Komulainen, and Ulkuniemi (2021) deductively analyzed the impact of technological innovation environment on three dimensions of consumers shopping experience: channel choice, value dimension and social interaction.

These studies usually used value model, attitude model and consumer decision-making behavior model to study consumers' purchasing decisions in shopping malls considering cultural differences, psychological factors, brand, layout design and technical factors. Airport shopping malls as a special commercial complex, scholars have made certain achievements in the study of consumer psychological factors and behavioral factors on consumers' purchasing decisions. However, few studies use the combination of qualitative and quantitative analysis to study the influencing factors of the whole process of purchasing decisions based on EKB theory.

### KEY FACTORS IDENTIFICATION AND HYPOTHESIS DEVELOPMENT

This study adopts the grounded theory method to identify key factors from semi-structured interview data and online reviews. Grounded theory can help researchers pay attention to the accuracy of the problem and avoid the ambiguity of the method. It can overcome the problem of insufficient reliability of qualitative research and poor validity of quantitative research, so as to obtain more scientific and reliable results (Cutcliffe, 2000). Grounded theory method does not require any theoretical hypothesis, but an in-depth analysis of the data to extract concepts that reflect the research question and develops these concepts into a theoretical framework.

First, this study conducted a 3-day field survey at Beijing Daxing International Airport in May 2023, and conducted semi-structured interviews with 3 airport commercial managers from 5 topics, including store location layout, products display, advertising promotion, service, and social environment. Second, this study collected a total of 2,000 online review data from well-known domestic social platform Xiaohongshu and Dianping in China. After eliminating invalid comments, a total of 1,605 valid comments were obtained, and 1205 comments were used for three-level coding. The remaining data was used for saturation test.

#### Interview Data Analysis

Based on the interview data, we conducted a comprehensive discussion with the researchers of our team and extracted six core constructs, including online word of mouth, perceived risk, perceived quality, perceived price, situational factors and shopping values (see Table 1)

Table 1: Key factors

Topics	Interviews	Key constructs
(1) Store location layout	"An Internet celebrity brand originally had more than 20 stores in downtown Beijing, and when the airport really opened, there was only one airport. And so does the brand of Niu Jiao Village"	eWOM
(2) Products display	"It takes a long time to eat hot pot, it is suitable for party communication, passengers may want to eat within 40 minutes, boarding time may be it is not hot"	Perceived risk
(3) Advertising promotion	"If we could only choose between service and value, we would definitely choose service" "The airport and (a brand) cooperate to create ice cream, and the quality can be controlled" "The satellite hall is still under construction"	Perceived quality

(4) Service	“At Changi Airport, the cost per passenger is \$300, while we are still struggling with \$30”	
(5) Social environment	“The prices here are so good that we all eat it ourselves, and it's cheap to get our own marketing coupons”	Perceived price
	“The strength of (a brand of coffee) is a low price, which realizes the civilian price of coffee”	
	“For customized packages, all dishes are required to be served within a certain time, all our restaurants require 20 minutes to serve, but in fact, the average time for dinner is more than ten minutes”	Situation factors
	“Because it is a category of sightseeing, if the passengers do not have a sense of sightseeing experience, they will not want to visit”	
	“Passengers are very concerned about the cost performance of the brand”	Shopping value

## Online Review Data Analysis

### Open coding

Open coding is to analyze the original text data word by word and extract all the concepts contained in the text data according to the problem to be studied. In the process of open coding, it is necessary to analyze objectively and comprehensively to avoid the influence of personal subjective factors on research problems. This study repeatedly analyzed, sorted and summarized the collected text review data, and finally formed 32 initial categories. The specific process of open coding is shown in column of Table 2.

### Axial coding

According to the process of programmatic grounded theory, after open coding, the original text data is extracted into different types of initial concepts, and the relationship between various categories is established through spindle coding. Through sorting out the relationship between each category, further excavating and refining the higher level of the main category. This study summarizes and analyzes 32 initial concepts and comes up with 6 main categories (see Table 2).

Table 2: The results of open and axial coding for online review.

Core category	Sub-categories	Concepts	Partial original material
eWOM	Friend recommendation	It's worth trying; Highly recommend	“Recently, I heard a friend say ... .. Good place to go shopping and consumption, thanks to the recommendation of friends”
	Online reviews	Xiaohongshu grass; Reference others' evaluation	“... Last time I saw on the Internet today finally came to punch, did not disappoint me”
Perceived risk	Time pressure	Arrive too early; Catch a flight	“First time to Beijing Daxing Airport... Time is too rushed, early to know the point to arrive, too easy to visit”
	Shopping risk	Easy to pick up and return goods; Direct home mail	“Products can be mailed or picked up on the way home”
Perceived quality	Product quality	Rich brand; Complete variety; Meet different needs	“... The quality is still good, and the variety is great”
	Service quality	Recommend patiently; Warm service; Praise	“Compared to other shops downtown... A lot of enthusiasm, a very good attitude, like...”
Perceived price	Physical environment	Good environment; Beautifully decorated; Quiet	“.. It's new and large, and the windows are clean and bright... Facilities, shops, everything...”
	Tax exemption discount	Cheaper after tax exemption; The more you buy, the better	“You can store duty-free goods, buy more and get a discount ...” .. It can be delivered, purchased online and discounted...

Situational factor	Residence time	Shopping in a hurry; Plenty of time	“It’s still a while before boarding... Just walk in.”
	Location	Close to the boarding gate; Store location; Clearly marked	“I can see it after security, it was in a very visible position... The checkout line takes less than ten minutes.”
Shopping value	hedonism	Pleasure and relaxation; Great experience; Personalized shopping	Shopping gives me a great experience... added a lot of color to my journey.
	utilitarianism	Achieve the purpose of shopping; High cost performance	“... the quality is good and the price is reasonable. It is suitable for friends.”

**Selective coding**

Selective coding involves the integration of the main categories that have been developed to form the initial theoretical framework. In this paper, six core categories are identified in the axis coding, which are eWOM, perceived risk, perceived quality, perceived price, situational factors and shopping values. Through the definition of the core categories, it is found that these six core categories all point to the research theme of this paper, that is, purchasing decision. Therefore, as shown in Figure 1, the framework of influencing factors of purchasing decision of consumers in airport shopping malls is constructed in this paper.

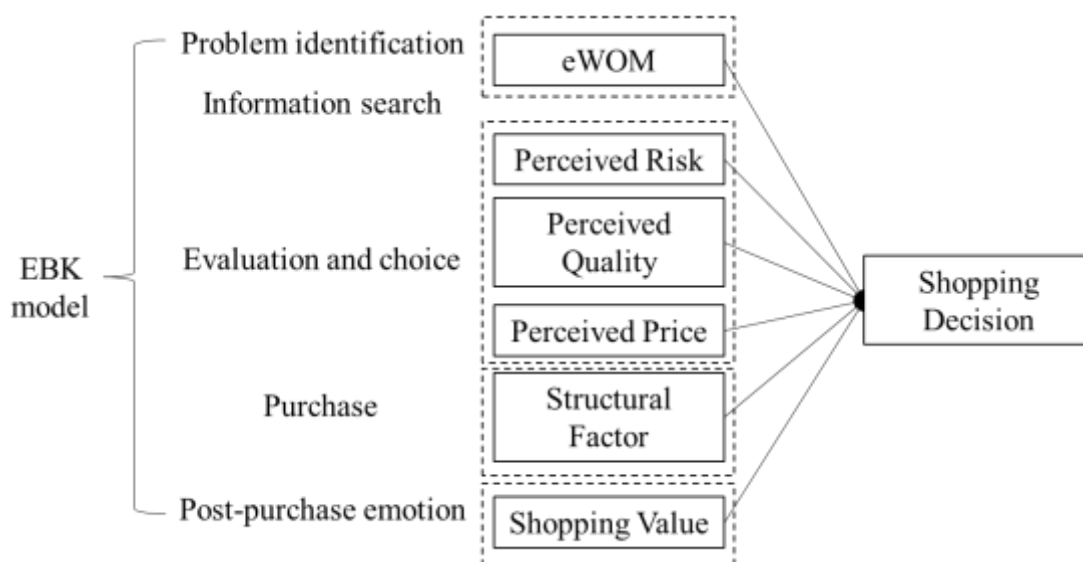

Figure 1: Consumer purchase decision model.

**Saturation test**

It is necessary to verify the saturation of the theoretical model after three-level coding. If there are no new concepts and categories, it indicates that the theoretical model is relatively perfect or reaches the theoretical saturation state. If there are new conceptual categories, the text data should be repeatedly compared with three levels of coding until no new conceptual categories appear and the theory is saturated. In this study, 400 online reviews were used for testing, and no new concepts were generated, indicating that the theoretical saturation test met the requirements.

**Hypothesis Development**

Consumers' information search and identification mainly come from online word-of-mouth, such as online reviews and friend recommendation. Consumers tend to seek input from others before making a purchase decision. Consumers analyze and screen information in eWOM to build trust and generate emotional experience resonance (Cheung & Thadani, 2012). Su, Wu, Lin, and Lin (2023) indicated that eWOM can significantly affect consumers' purchase intention. Therefore, we propose:

H1. eWOM is positively correlated with purchase intention.

In the evaluation and choice stage, the perceived experience of shopping includes perceived risk, perceived quality and perceived price, which will affect whether consumers are willing to pay a certain cost to obtain the desired product or service. As far as shopping at airports is concerned, consumers' perceived risk stems from products available and their time. Consumers will reduce their intention to buy when they perceive high risk (Han, Kim, & Hyun, 2014).

H2. Perceived risk is negatively correlated with purchase intention.

Service quality and price significantly influence consumer satisfaction (Liliana & Shafamila Handininta, 2022). In shopping malls, perceived quality refers to consumers' evaluation of commodity performance, shopping environment comfort and

service quality. Perceived price has an important impact on consumers' willingness to buy, and consumers tend to balance the price of goods with their own budgets to ensure that consumer spending is within acceptable limits (N' da, Ge, Ji-Fan Ren, & Wang, 2023) . Thus,

H3. Perceived quality is positively correlated with purchase intention.

H4. Perceived price is negatively correlated with purchase intention.

Airport shopping mall is a special context. When consumers choose whether to make a purchase, they usually consider the convenience of the mall and the time spent on shopping. The above review text analysis draws on the shopping situational factors. Time pressure and convenience can significantly influence consumers' purchasing decisions (Anselmsson, 2016) . When consumers feel that shopping is convenient and fast, they will be more willing to buy. Thus,

H5. Situational factors are positively correlated with purchase intention.

In the post-purchase emotional stage, the hedonistic value of consumer shopping value tends to be emotionally driven, such as paying attention to shopping experience and emotional connection; Utilitarian values seek to maximize efficiency (Y.-S. Chung, 2015). Shopping values play a guiding and shaping role in consumers' emotional cognition, which directly leads to the emergence of purchasing behavior.

H6. Shopping value is positively correlated with purchase intention.

## METHODOLOGY

### Measurement

The questionnaire consists of two parts: the first part is the basic information of the surveyed consumers, and the second part measures the 7 latent variables, such as eWOM, perceived risk, perceived quality, perceived price, situational factor, shopping value, and shopping decision. A five-level Likert scale was used to measure all survey items, ranging from “strongly disagree” to “strongly agree” . These items are derived from existing literature and adapted to the research contexts (see Table 3).

Table 3: Measurement items.

Constructs	Items	References
eWoM (EW)	EW1. There are many positive comments about the shopping at Daxing Airport on social media platforms.	Apiraksattayakul, Papagiannidis, and Alamanos (2017)
	EW2. My friends on social media platform recommend shopping at the airport.	
	EW3. Online reviews on social media platforms rated the airport malls as a good experience	
	EW4. Reviews on social media platforms indicate that the quality of product and services at Daxing Airport shopping malls are good	
Perceived risk (PR)	PR1. Shopping at Daxing Airport is usually a rush	Han, Lee, and Kim (2018); Vafaei-Zadeh et al. (2022)
	PR2. Shopping at Daxing Airport, returns/exchanges/claims are difficult.	
	PR3. Shopping at Daxing Airport, I get lost.	
Perceived quality (PQ)	PQ1. I believe the products purchased at Daxing Airport are of good quality.	Han et al. (2018); Tran, Taylor, and Wen (2023)
	PQ2. I feel that the shopping environment of Daxing Airport is comfortable.	
	PQ3. The staff at Daxing Airport shop are friendly.	
Perceived price (PP)	PP1. I tend to buy goods or services with coupons.	Khare, Ahtani, and Khattar (2014)
	PP2. I believe that the goods are expensive at Daxing Airport. PP3. I think there are too few coupons at Daxing Airport.	
	PP4. I think it is difficult to buy duty-free goods at lower prices at Daxing Airport.	

Situational factors (SF)	SF1. When shopping at Daxing Airport, I will consider whether the location of the shopping area is convenient.	Calvo-Porrall and Lévy-Mangín (2018); Lee, Choi, and Park (2017)
	SF2. When shopping at Daxing Airport, I feel time pressure.	
	SF3. I usually choose to shop after checking in.	
Shopping value (SV)	SV1. I enjoyed shopping at Daxing Airport.	Arnold and Reynolds (2009); Y.-S. J. J. o. A. T. M. Chung (2015)
	SV2. The shopping experience at Daxing Airport is very good.	
	SV3. I can get what I want at Daxing Airport.	
	SV4. I can buy some useful goods at Daxing Airport.	
Shopping decision (SD)	SD1. I will continue to shop at Daxing Airport.	Y.-S. Chung (2015); Santo and Marques (2022); Vafaei-Zadeh et al. (2022)
	SD2. Whenever I get the chance, I shop at Daxing Airport.	
	SD3. I would recommend shopping at Daxing Airport.	

### Data Collection

Before the formal survey, the researchers sent the designed questionnaire to 5 consumers who had shopping experience in Daxing International Airport to fill out, and asked them whether these items were reasonable, and adjusted and improved these questions according to the feedback. The formal questionnaire is published in the form of a link on WeChat, QQ and other platforms, and users who fill in the questionnaire are given a certain reward. An open-ended question ( "Have you had any shopping experience at Daxing Airport before" ) was used to screen respondents and identify target participants.

A total of 400 questionnaires were sent out, 350 were recovered, and 314 were valid, with an effective recovery rate of 89.71%. Table 4 shows the demographics of the sample. Among them, 47.10% were male and 52.90% were female. More than two thirds of the respondents were between 21 and 40 years old, and the most purchased products were food and beverage.

Table 4: Demographic statistics of respondents (N=314).

Item	Categories	Count	(%)	Item	Categories	Count	(%)
Gender	Male	148	47.10%	Annual number of flights	0-2 times	116	36.90%
	Female	166	52.90%		3-5 times	172	54.80%
	<= 20	21	6.70%		Above 5 times	26	8.30%
Age	21-30	98	31.20%	Spare time before boarding	Less than half an hour	50	15.90%
	31-40	111	35.40%		Half an hour - an hour	132	42.00%
	41-50	56	17.80%		An hour - two hours	111	35.40%
	> 50	28	8.90%		More than 2 hours	21	6.70%
Income	3000 and below	26	8.30%	Type of product purchased	Apparel	234	74.50%
	3001-5000	38	12.10%		Cosmetics and Skincare	81	25.80%
	5001-7000	132	42.00%		Food and beverage	261	83.10%
	7001-9000	95	30.30%		Electronic products	151	48.10%
	9001-11000	20	6.40%		Gifts and Souvenirs	206	65.60%
	More than 11000	3	1.00%		Others	1	0.30%

### Measurement Model Results

The research model was evaluated using a two-step approach recommended by (Anderson & Gerbing, 1988). The first step analyzes the measurement model to establish the reliability and validity of the measures, while the second tests the structural relationship among the latent constructs.

SmartPLS 4.0 was the primary statistical analysis tool used because it emphasizes maximizing the explanatory power over confirmatory theory-model congruence on which the covariance-based SEM is focused (Ringle, Sarstedt, Schlittgen, & Taylor, 2013). The PLS-SEM places minimal restrictions on the measurement scales, sample size, and residual distribution (Chin & Newsted, 1999).

Internal Consistency Reliability is used to evaluate whether the items in the questionnaire have stable measurement results. Composite Reliability value is used to assess internal consistency. CR value exceeding 0.70 indicates a very good internal consistency (Hair, Sarstedt, Matthews, & Ringle, 2016). As shown in Table 5, CR and Cronbach's Alpha values are all over 0.70, indicating the measurement model is reliable. The rho\_A coefficient is used to test the reliability of PLS construct scores, and the value above the threshold of 0.7 further indicates good reliability (Dijkstra & Henseler, 2015).

Table 5 shows that the factor loading of all constructs exceed 0.8, and the Average Variance Extraction values exceed 0.6, indicating good convergence validity. Discriminant Validity was tested using the criterion that the square root of AVE for each construct is greater than its correlations with other constructs (Fornell & Larcker, 1981). Table 6 shows the criterion has been satisfied, indicating good discriminant validity.

Table 5: Psychometric properties of the measurement scales.

Constructs	Items	Loadings	Cronbach's Alpha	rho_A	CR	AVE
eWoM	EW1	0.846	0.845	0.849	0.896	0.683
	EW2	0.819				
	EW3	0.825				
	EW4	0.815				
Perceived Risk	PR1	0.838	0.799	0.801	0.882	0.713
	PR2	0.840				
	PR3	0.855				
Perceived Quality	PQ1	0.834	0.821	0.827	0.893	0.736
	PQ2	0.867				
	PQ3	0.871				
Perceived Price	PP1	0.851	0.861	0.862	0.905	0.705
	PP2	0.832				
	PP3	0.855				
	PP4	0.821				
Situational Factor	SF1	0.856	0.809	0.811	0.887	0.724
	SF2	0.828				
	SF3	0.868				
Shopping Value	SV1	0.831	0.854	0.855	0.901	0.696
	SV2	0.839				
	SV3	0.842				
	SV4	0.825				
Shopping Decision	SD1	0.871	0.841	0.842	0.904	0.759
	SD2	0.876				
	SD3	0.867				

Table 6: A correlation matrix with AVE's square root.

	EW	PR	PQ	PP	SF	SV	SD
eWoM (EW)	<b>0.826</b>						
Perceived Risk (PR)	-0.387	<b>0.844</b>					
Perceived Quality (PQ)	0.414	-0.382	<b>0.858</b>				
Perceived Price (PP)	-0.346	0.398	-0.475	<b>0.840</b>			
Situational Factor (SF)	0.483	-0.367	0.519	-0.438	<b>0.851</b>		
Shopping Value (SV)	0.419	-0.397	0.459	-0.420	0.443	<b>0.834</b>	
Shopping Decision (SD)	0.491	-0.434	0.535	-0.464	0.539	0.521	<b>0.871</b>

Note: Diagonal elements are the square roots of the AVE

### Structural Model Results

Using the bootstrapping method with 5000 replicates, the structural model of the entire sample was tested for path significance and explanatory power. Figure 2 show the results of structural model. All hypotheses are supported.

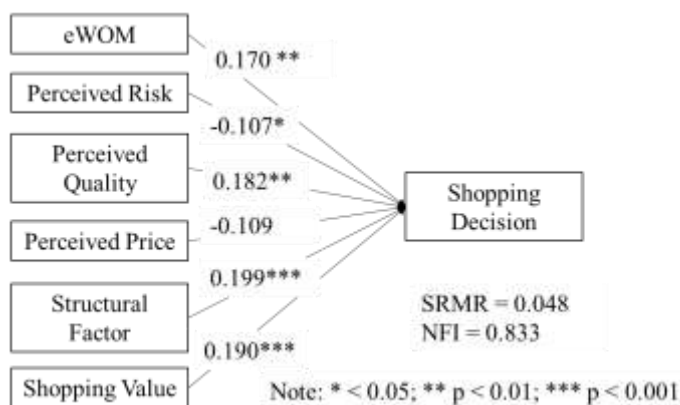

Figure 2: Results of structural model analysis.

The value of SRMR below 0.08 indicates a good fit of the model. The NFI value is greater than or equal to 0.90, indicating that the model has a good fit, and the NFI value greater than 0.8 is considered acceptable. The SRMR and NFI indexes of the structural model fit are 0.048 and 0.833 respectively, indicating the structural model fit is within a reasonable range.

### DISCUSSION AND IMPLICATION

Based on EKB model, combined with existing research and the special situation of airport shopping mall, this paper draws the following conclusions and suggestions through qualitative research, questionnaire survey and structural equation research.

#### Key Findings

This study finds that online word-of-mouth, as an important reference information for consumers' decision-making, involves various aspects such as product performance, brand reputation, and customer service, and plays an important role in consumers' purchasing decisions. This is consistent with the findings of Reza Jalilvand and Samiei (2012). Consumers are more likely to trust the real experiences of other consumers (King, Racherla, & Bush, 2014), so it is of great value to explore the information contained in eWOM.

Perceived risk has a significant negative effect on shopping decisions, and too high perceived risk will make consumers adopt a more conservative attitude when making purchase decisions. Perceived quality and situational factors have significant positive effects on purchasing decisions, while perceived price has significant negative effects on purchasing decisions. In the airport shopping environment, consumers hope to obtain more satisfactory perceived quality within a limited time. Therefore, quality will affect consumers' trust in products, thus enhancing their purchase decision intention. Consumers pay more attention to situational factors such as convenience and timing when shopping at airports, such as the security checks, the often long distances between passport control and the gates, time pressure and the generally non-familiar environment et al. In addition, shopping values have a significant positive effect on shopping decisions, which means that both hedonistic and utilitarian shopping values can positively affect consumers' purchasing decisions.

#### Implications



Firstly, EKB model provides a value theoretical perspective for us to explore the purchasing decisions of consumers at airport shopping malls. EKB model has been applied by scholars to the research of consumer purchase decision in various fields, and the validity of this model has been established. Based on online reviews, this paper studies the influence of purchasing decision of consumers at airport shopping malls, and verifies the validity of EKB model in shopping malls context, which extends the research of purchasing decision behavior in airport shopping malls context.

Secondly, airport managers and retailers should pay attention to the impact of online word of mouth, perceived risk, perceived quality, perceived price, situational factors and shopping values on consumers' purchase decisions, especially situational factors and shopping values. The findings are of great significance to the commercial managers of airport shopping malls. An in-depth understanding of consumers' shopping psychology and emotional cognition will help commercial managers accurately grasp consumer needs to carry out precision marketing, and then promotes the sustainable development of airport retail industry.

### Limitations and Future Research

Consumers' purchasing decision in shopping malls context is a complex process, so it may be too simple to consider only the direct effect of various factors, and the process model should be value to be considered for discussion in future research. Since this study is based on text review data, there may be data inauthenticity such as fake reviews, so there may be bias in the process of refining the core categories of online review data. In the future, targeted interviews and other first-hand data can be conducted for consumer users to obtain more practical research value.

### ACKNOWLEDGMENT

This research was supported by Kunming E-commerce and Internet Finance R&D Center (KEIRDC [2020]), the Prominent Educator Program (Yunnan [2018]11), Yunnan Provincial E-Business Entrepreneur Innovation Interactive Space (2017DS012), 2021 Yunnan Provincial Academic Degrees Committee Program [SJZYXWALK202113], 2021 Yunnan University Program [XJKCSZ202117, 2022XJYZKC11, 2022Y35].

### REFERENCES

- Alavi, S. A., Rezaei, S., Valaei, N., & Wan Ismail, W. K. (2015). Examining shopping mall consumer decision-making styles, satisfaction and purchase intention. *The International Review of Retail, Distribution and Consumer Research*, 26(3), 272-303. <https://doi.org/10.1080/09593969.2015.1096808>
- Anderson, J. C., & Gerbing, D. W. (1988). Structural equation modeling in practice: A review and recommended two-step approach. *Psychological bulletin*, 103(3), 411.
- Anselmsson, J. (2016). Effects of shopping centre re-investments and improvements on sales and visit growth. *Journal of Retailing and Consumer Services*, 32, 139-150. <https://doi.org/10.1016/j.jretconser.2016.06.009>
- Apiraksattayakul, C., Papagiannidis, S., & Alamanos, E. J. I. J. o. O. M. (2017). Shopping via Instagram: The influence of perceptions of value, benefits and risks on purchase intentions. 7(4), 1-20.
- Arnold, M. J., & Reynolds, K. E. J. J. o. r. (2009). Affect and retail shopping behavior: Understanding the role of mood regulation and regulatory focus. 85(3), 308-320.
- Calvo-Porràl, C., & Lévy-Mangin, J.-P. (2019). Profiling shopping mall customers during hard times. *Journal of Retailing and Consumer Services*, 48, 238-246. <https://doi.org/10.1016/j.jretconser.2019.02.023>
- Calvo-Porràl, C., & Lévy-Mangín, J.-P. (2018). Pull factors of the shopping malls: an empirical study. *International Journal of Retail & Distribution Management*, 46(2), 110-124. <https://doi.org/10.1108/ijrdm-02-2017-0027>
- Cheung, C. M. K., & Thadani, D. R. (2012). The impact of electronic word-of-mouth communication: A literature analysis and integrative model. *Decision Support Systems*, 54(1), 461-470. <https://doi.org/10.1016/j.dss.2012.06.008>
- Chung, Y.-S. (2015). Hedonic and utilitarian shopping values in airport shopping behavior. *Journal of Air Transport Management*, 49, 28-34. <https://doi.org/10.1016/j.jairtraman.2015.07.003>
- Cutcliffe, J. R. J. J. o. a. n. (2000). Methodological issues in grounded theory. 31(6), 1476-1484.
- Dijkstra, T. K., & Henseler, J. (2015). Consistent partial least squares path modeling. *MIS Quarterly*, 39(2), 297-316.
- Fornell, C., & Larcker, D. F. (1981). Evaluating structural equation models with unobservable variables and measurement error. *Journal of marketing research*, 18(1), 39-50.
- Hair, J., Joe F, Sarstedt, M., Matthews, L. M., & Ringle, C. M. (2016). Identifying and treating unobserved heterogeneity with FIMIX-PLS: part I—method. *European Business Review*, 28(1), 63-76.
- Han, H., Kim, W., & Hyun, S. S. (2014). Overseas travelers' decision formation for airport-shopping behavior. *Journal of Travel & Tourism Marketing*, 31(8), 985-1003. <https://doi.org/10.1080/10548408.2014.889643>
- Han, H., Lee, M. J., & Kim, W. J. I. J. o. C. H. M. (2018). Role of shopping quality, hedonic/utilitarian shopping experiences, trust, satisfaction and perceived barriers in triggering customer post-purchase intentions at airports. 30(10), 3059-3082.
- Khare, A., Ahtani, D., & Khattar, M. (2014). Influence of price perception and shopping motives on Indian consumers' attitude towards retailer promotions in malls. *Asia Pacific Journal of Marketing and Logistics*, 26(2), 272-295. <https://doi.org/10.1108/apjml-09-2013-0097>
- King, R. A., Racherla, P., & Bush, V. D. (2014). What We Know and Don't Know About Online Word-of-Mouth: A Review and Synthesis of the Literature. *Journal of Interactive Marketing*, 28(3), 167-183. <https://doi.org/10.1016/j.intmar.2014.02.001>

- Ko, H., Roberts, M. S., & Cho, C.-H. (2006). Cross-Cultural Differences in Motivations and Perceived Interactivity: A Comparative Study of American and Korean Internet Users. *Journal of Current Issues & Research in Advertising*, 28(2), 93-104. <https://doi.org/10.1080/10641734.2006.10505201>
- Krey, N., Picot-Coupey, K., Cliquet, G. J. J. o. R., & Services, C. (2022). Shopping mall retailing: A bibliometric analysis and systematic assessment of Chebat's contributions. 64, 102702.
- Lee, K.-Y., Choi, Y.-J., & Park, J.-W. (2017). A Study on Effects of Time Pressure Perceived by Users of Airport Duty-free Shop on Impulsive Purchasing Behavior and repurchase Intention. *International Business Research*, 11(1). <https://doi.org/10.5539/ibr.v11n1p59>
- Liliana, D., & Shafamila Handininta, P. (2022). Service Quality, Customer Value, and Price to Consumer Satisfaction at Kopi Kenangan Coffee Shop. *International Journal of Social Science*, 1(6), 987-992. <https://doi.org/10.53625/ijss.v1i6.1918>
- N'da, K., Ge, J., Ji-Fan Ren, S., & Wang, J. J. P. o. (2023). Perception of the purchase budget (BGT) and purchase intention in smartphone selling industry: A cross-country analysis. 18(7), e0279575.
- Park, H., & Cho, H. (2012). Social network online communities: information sources for apparel shopping. *Journal of Consumer Marketing*, 29(6), 400-411. <https://doi.org/10.1108/07363761211259214>
- Reza Jalilvand, M., & Samiei, N. (2012). The effect of electronic word of mouth on brand image and purchase intention. *Marketing Intelligence & Planning*, 30(4), 460-476. <https://doi.org/10.1108/02634501211231946>
- Ringle, C. M., Sarstedt, M., Schlittgen, R., & Taylor, C. R. (2013). PLS path modeling and evolutionary segmentation. *Journal of Business Research*, 66(9), 1318-1324.
- Santo, P. E., & Marques, A. M. A. J. B. J. o. M. (2022). Determinants of the online purchase intention: hedonic motivations, prices, information and trust. 17(1), 56-71.
- Sharma, R., Mohan, M., & Gupta, S. (2022). The effect of mall ambience, layout, and utility on consumers' escapism and repurchase intention. *Innovative Marketing*, 18, 161-173. [https://doi.org/10.21511/im.18\(4\).2022.14](https://doi.org/10.21511/im.18(4).2022.14)
- Su, B.-C., Wu, L.-W., Lin, H., & Lin, C.-A. (2023). The Mediating Effect of Herd Behavior and Brand Attitude towards the Impact of Spokesman Credibility, Source Fit, and Online Word-of-Mouth on Purchase Intention. *Sustainability*, 15(1). <https://doi.org/10.3390/su15010888>
- Svitek, M., Řehoř, V., Vittek, P., & Dvořáková, T. (2021). Smart airports-developing demand side system services. Paper presented at the 2021 Smart City Symposium Prague (SCSP).
- Tran, T., Taylor, D. G., & Wen, C. J. J. o. R. i. I. M. (2023). Value co-creation through branded apps: enhancing perceived quality and brand loyalty. 17(4), 562-580.
- Vafaei-Zadeh, A., Wong, T.-K., Hanifah, H., Teoh, A. P., Nawaser, K. J. R. i. T. B., & Management. (2022). Modelling electric vehicle purchase intention among generation Y consumers in Malaysia. 43, 100784.
- Wei Khong, K., & Sim Ong, F. (2014). Shopper perception and loyalty: a stochastic approach to modelling shopping mall behaviour. *International Journal of Retail & Distribution Management*, 42(7), 626-642. <https://doi.org/10.1108/ijrdm-11-2012-0100>
- Ylilehto, M., Komulainen, H., & Ulkuniemi, P. (2021). The critical factors shaping customer shopping experiences with innovative technologies. *Baltic Journal of Management*, 16(5), 661-680. <https://doi.org/10.1108/bjm-02-2021-0049>
- Zhang, K. Z. K., Zhao, S. J., Cheung, C. M. K., & Lee, M. K. O. (2014). Examining the influence of online reviews on consumers' decision-making: A heuristic-systematic model. *Decision Support Systems*, 67, 78-89. <https://doi.org/10.1016/j.dss.2014.08.005>

## Investigating Information Systems Vulnerabilities Using Machine Learning Algorithms

Shiyun Hao<sup>1</sup>  
Weihua Li<sup>2</sup>  
Xiong Zhang<sup>3,\*</sup>

\*Corresponding author

<sup>1</sup> Graduate student, Beijing Jiao Tong University, Beijing, China, 21120609@bjtu.edu.cn

<sup>2</sup> Lecturer, Beijing Daxing District No. 1 Vocational School, Beijing, China, li\_weihua0814@163.com

<sup>3</sup> Associate Professor, Beijing Jiao Tong University, Beijing, China, xiongzhang@bjtu.edu.cn

### ABSTRACT

Companies and organizations equipped with IT infrastructure usually face security threats due to vulnerabilities in information systems. This paper aims to build models using intelligent algorithms to automatically identify vulnerability types and predict risk levels. We first collect reports from a Chinese vulnerability crowd-testing platform, then establish models by using textual representation technologies, shallow and deep learning algorithms. The experimental results show that the deep learning model with neural text representation could achieve better performance of vulnerability identification and risk level prediction. This research contributes to the information security literature and could help companies and organizations to more efficiently fix information systems vulnerabilities.

*Keywords:* Vulnerability, Information Security, Deep Learning, Text Representation, Identification and Prediction

### INTRODUCTION

IT infrastructure and information systems are playing critical roles in operations and management among enterprises. Organizations in the age of cloud computing are facing the critical issue of integrating software (Zhang and Yue 2020). Cybersecurity issues such as data breaches due to information system vulnerabilities continue to be a major concern for firms. A report pointed out that vulnerability exploitation is one of the manners to do harm to data assets (Verizon 2022). Attackers exploit vulnerabilities to compromise information systems in enterprises. Thus, than ever before, firms are paying more attention to information systems vulnerabilities by heavily investing on human resource and R&D. Therefore, the key now is how to comprehensively understand the nature among various types of information systems vulnerabilities and their risk levels in order to fix vulnerabilities more efficiently. This study makes efforts towards this target by investigating vulnerability reports using machine learning algorithms.

This study constructed a dataset including reports of information security events from a well-known vulnerability crowd-testing platform in China. Such platforms could provide data for us to investigate information systems vulnerabilities. The platform improves the effectiveness of vulnerability mining, and increases the depth and breadth of mining of enterprise assets (Li and Zhao 2022).

The models we adopted in this study contain both traditional machine learning algorithms and artificial neural network. Different text representation methods are used for feature extraction of vulnerability reports. Both discrete representation and distributed representation are adopted and their performance are compared. We represent the text data as a matrix utilizing TF-IDF (Xue *et al.* 2019), BoW and N-gram. Besides, we denote the topics of each vulnerability report in a probability distribution by using the Latent Dirichlet Allocation model. Their topic distributions are extracted for subsequent experiments to classify the types of vulnerabilities and to predict risk levels of different kinds of vulnerabilities. In the experiment of artificial neural network, we use Word2Vec method to pre-process the text data of detailed descriptions of all vulnerabilities. Experiment results show that multilayer perceptron with neural text representation could achieve higher performance in both vulnerability identification and risk level prediction. This research has both theoretical and practical implications.

### LITERATURE REVIEW

Existing studies have investigated vulnerabilities from perspectives of disclosure mechanisms, the interplay between firms and vulnerabilities, automatic detection of vulnerabilities, among others.

The mechanism of vulnerability disclosure is a complex issue. (Ahmed *et al.* 2021) proposed a comprehensive framework to examine the mechanisms of vulnerability disclosure from both market and non-market perspectives through a systematic literature review. This framework helps to comprehensively compare the two disclosure mechanisms. (Ransbotham *et al.* 2016) identified four types of relationships between digital vulnerabilities and ubiquitous IT: increased visibility, enhanced cloaking,

increased interconnectedness, and decreased costs. Ubiquitous computing makes various entities more vulnerable to attacks through these four mechanisms.

Some scholars explored the interplay between vulnerabilities and companies. (Zhuang et al. 2020) investigated the influence of awareness of a security vulnerability index on firm's security protection strategy, incentives and country-wide level of information technology (IT) development. Experimental results showed that countries in the Asia-Pacific region with high levels of ICT development are more responsive to cybersecurity vulnerabilities. (Wang et al. 2009) studied the impacts of cyber security on the firms with a focus on how disclosures of information security affected a firm's security management strategy. They found that the textual content of security risk could be used to predict future breaches. Some empirical studies have shown that information security incidents have negative impacts on company operations (Ye & Zhang 2021). Security vulnerabilities, which are an important part of information security incidents, also have a negative impact on the market value of firms (Niu et al. 2022). Some studies have also explored the response of companies to network vulnerabilities, where the vulnerability risk levels and vulnerability types have a significant impact on the companies' ability to fix vulnerabilities (Hao et al. 2021). These studies provide management insights for company managers.

Recently, researchers examined the automation processes to detect vulnerabilities. (Grieco & Dinaburg 2018) proposed a proof-of-concept tool: a central development organizer, to optimize the detection tools of vulnerability, and help to specify initial values of parameters for a given vulnerability detection tool. (Spanos et al. 2017) adopted text mining techniques to analyze the vulnerability samples and confirmed the importance of vulnerability descriptions for vulnerability risk classification. They tested the effectiveness of TF-IDF representation against the simple word frequency representation. (Ruohonen 2017) identified attacks on open-source software vulnerabilities by using topic modeling tools and random forest classifiers. (Yitagesu et al. 2021) designed unsupervised word embedding models based on CBOW, combined it with negative sampling methods to extract features from security vulnerability. They proposed a method to assign part-of speech tags to tokens in detailed descriptions of vulnerabilities. (Wu et al. 2021) used the Word2Vec tool to convert tokens into vectors as inputs to the neural network for automatic vulnerability detection. (Zhang et al. 2020; Zhang et al. 2020) propose a general framework to understand vulnerabilities by using topic model and machine learning algorithms, and the framework helps to characterize the patterns and regularities of various type of vulnerabilities.

This study follows the research stream of automatic detection of vulnerabilities. But different from existing literature, this study focuses on the detailed description in textual data from vulnerability reports. We collected vulnerability reports from a well-known Chinese crowdsourcing testing platform. Various programming languages (e.g., C, C#), both Chinese and English comments, typos, URLs, screenshots, among others, exist in vulnerability reports, leading to difficulty in vulnerability mining. We combined text representation techniques with several state of art machine learning algorithms to automatically understand various vulnerabilities from a data-driven perspective. The work not only compares the ability of different text representation techniques on vulnerability report, but also compares the performance of machine learning model and artificial neural network in automatic identification of information system vulnerability.

## DATA SET

The data source is an information system vulnerability crowd-testing platform in China. The crowd-testing platform is a meritocratic learning community (Zhang et al. 2015). The raw data of 39503 information security events from 2010 to 2016 was collected using a Python crawler. 20 different attributes were included in each event, such as: vulnerability ID, poster, vulnerability title, detailed description, associated company, submission time, fix time, disclosure time, vulnerability type and risk level, fix solution, and so on. *Vulnerability ID* is a public ID given by the platform for widely recognized information security vulnerabilities or vulnerabilities that have been exposed. *Poster* detected vulnerabilities and reported them into the platform. *Vulnerability Title* provides a brief summary of the vulnerability events. *Description* and *Solution* are the detailed description of vulnerability and the potential fixing solutions. *Vulnerability Type* and *Vulnerability Risk Level* indicate the type vulnerabilities belong to and how much damage vulnerability may cause. There are three levels of vulnerability risk in the dataset: high, middle, and low. Among these attributes, our focus is on the type, risk level, description, and solutions of vulnerability report. Table 1 shows the partial information of one vulnerability report.

Table 1: Partial Information of One Vulnerability Report

Attribute	Value
Vulnerability ID	2016-168160
Poster	Boooooom
Vulnerability Title	Internal API leakage from docker cloud service
Description	The place where the image is created supports the use of doc file for construction ...
Solution	Isolate the API of your own service from the user environment ...
Vulnerability Type	Design Defect/Logic Error
Vulnerability Risk Level	High

Associated Company	NetEase
Post Time	January 7, 2016
Fix Time	January 31, 2016
Release Time	February 22, 2016
Vulnerability Status	Vulnerability Post: 2016-1-7, waiting for confirmation of firm Vulnerability Fix: 2016-1-31, Firm confirmed, details were sent to firm, and fixed by NetEase. Release: 2016-2-22, after fixing, detail information released to public.
Firm Response	Thanks for your clear description.

The dataset contains lots of unstructured noisy data. The detailed description of the vulnerability includes source code, images, comments, etc. Source codes may be in different programming languages, e.g., SQL, Java, C, C#. The text content can be in English and Chinese. Besides, the report may also include typos, special symbols, URLs, figures, and so on. The figures are mainly screenshots of source code, result output, and user interfaces, which are not included in this study.

## METHODOLOGY

This study analyzes vulnerability reports by combining textual representation methods, learning algorithms, and topic analysis. We extract features using different text representation methods and conduct experiments using algorithms of traditional machine learning and artificial neural network.

This study adopted two types of text representation. The first is statistical text representation, including word-level and document-level text representation techniques (Wawrzyński & Szymański 2021). Word-level text representation techniques could extract features from words, and these features can serve as the input to models of classification or prediction. This type of text representation techniques includes (1) TD-IDF assessing the importance of words in a document to a document or the importance of a document in a corpus, (2) Bag-of-Words models converting texts into vectors that represent the frequency of occurrence of a particular term, and (3) N-Gram models calculating the probability of occurrence of terms. The document-level representation technique uses Latent Dirichlet Allocation (LDA) to obtain document features and infer document topic distribution. We conduct experiments using features of both word and document levels.

The second type of text representation is neural text representation which is a word embedding model (Wawrzyński and Szymański 2021). Word2Vec is one of the language models that learn semantic knowledge in an unsupervised manner from a large number of texts. According to the difference between input and output, the word embedding method could be categorized into continuous bag-of-words model (CBOW, predicting the current value by context) and Skip-Gram (SG, use the current word to predict the context). To speed up the training process, we adopt training mechanisms of Hierarchical SoftMax (HS) and Negative Sampling (NS) combined with CBOW and SG separately. For the abovementioned two models and two training mechanisms, we would try out all the four combinations in this study.

Text classification can be accomplished by utilizing traditional machine learning algorithms or deep learning algorithms (Li et al. 2022). Traditional Machine learning algorithm adopted in our experiment includes Logistic Regression, Classification and Regression Trees, Random Forest, Gradient Boosting Decision Tree, and Support Vector Machines. The deep learning algorithm adopted in this study is Artificial Neural Network.

## EXPERIMENTS AND RESULTS

This section first describes the data preparation process, then shows how we conduct feature extraction, experimental process, and finally present the results of vulnerability type identification and risk level prediction. Figure 1 presents the whole process of the experiment.

### Data Preparation

We preprocess vulnerability reports in the following steps.

(1) Remove records missing detailed description. 39503 records in 16 types of vulnerabilities were collected in the crowdsourcing platform. Among them, 86 records missing detailed description were removed. We performed statistical analysis for the detailed vulnerability description during the initial processing. The average count of characters for the detailed description of vulnerabilities is about 859.52.

(2) Text data cleaning. The dataset is a mixture of both Chinese and English texts. We delete the URLs, numbers, punctuation, the numbered serial numbers with circles, and space among the text. We convert all uppercase letters to lowercase letters. Then, the texts of vulnerability detailed description were sliced by using the jieba module and stop words are removed. The stop-word list is constructed by combining the commonly used Chinese stop-word lists (from the Harbin Institute of Technology, Baidu, Si Chuan University, and CN) and English long stop-word lists.

(3) Rows with empty values and records with extremely short detailed descriptions are removed.

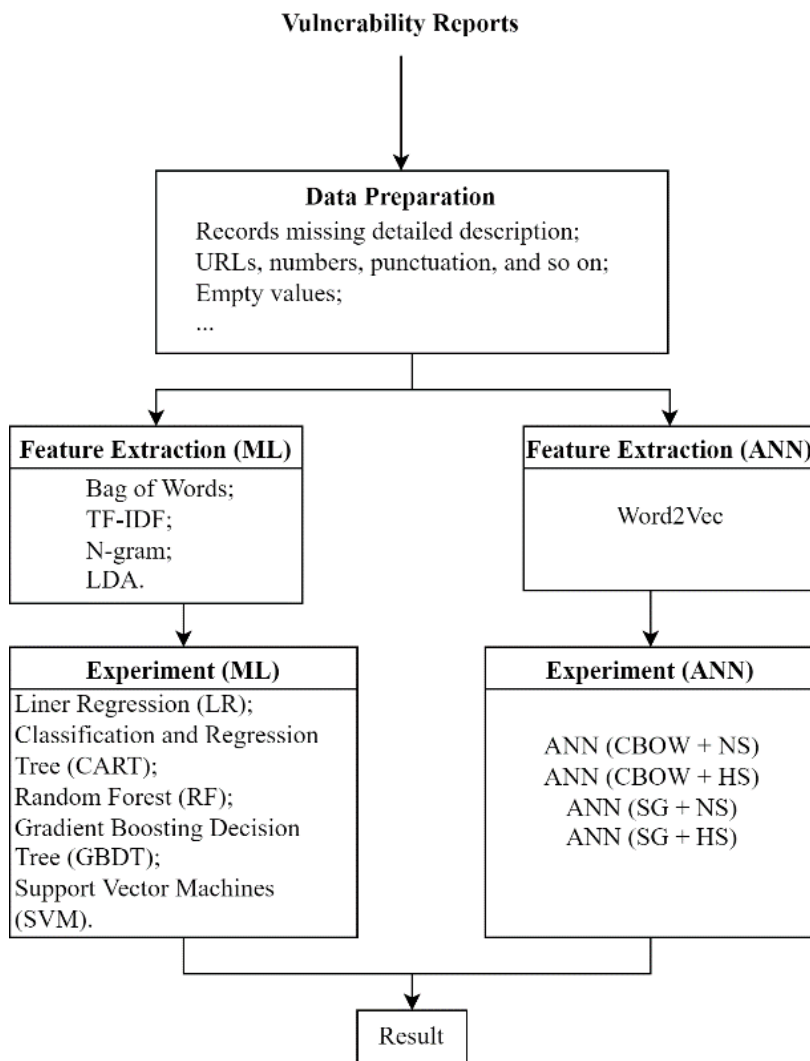

Figure 1: General Framework of Experiment

Finally, the dataset includes 30123 valid records. We present the count of vulnerabilities in terms of type and risk level in Table 2.

Table 2: Summary of Various Types of Vulnerabilities

Vulnerability Type	Risk Level			All
	High	Middle	Low	
Cross-site Scripting (XSS)	965	1078	742	2785
SQL Injection	5533	1573	311	7417
Weak Password	1696	575	148	2419
Successful Intrusion Event	821	108	66	995
Sensitive Information Disclosure	1797	775	420	2992
File Operation Vulnerability	1476	406	108	1990
Configuration Error	1175	373	196	1744
Design Defect/Logic Error	2797	1062	590	4449
Remote Code Execution	2068	435	91	2594
Unauthorized Access/Permission Bypass	1586	859	293	2738
All	19914	7244	2965	30123

Among all types of vulnerabilities, SQL injection, Design Defect/Logic Error and Sensitive Information Disclosure occur more frequently than other types of vulnerabilities. They account for almost 50% of the dataset.

## Feature Extraction

For traditional machine learning methods, features are extracted in three dimensions: BOW with n-grams, TF-IDF with n-grams, and document topics. The Bag-Of-Words model does not consider word order in sentences, it transforms a sentence into a vector representation based on the occurrences of the words in that sentence. In order to highlight the role of keywords in detailed descriptions, we also adopt TF-IDF method. Besides, we used a hybrid pattern of unigram and bigram combined with the text representation methods at the word level, to incorporate word order effects. Bi-gram is a maximum probability partition, which considers not only itself but also its antecedents when calculating the word probability. We set the number of topics in vulnerability reports to be 40, which is fairly large number to cover most topics in reports.

For ANN, we adopt the Word2Vec embedding method for text representation and feature extraction.

## Experiment

We adopt two text representation techniques and various classification algorithms to automatically identify the types of vulnerabilities and evaluate risk levels. First, we establish the models by combining statistical text representation techniques and traditional machine learning algorithms: LR, CART, RF, GBDT, and SVM. All the experiments were conducted using 5-fold cross validation. The whole dataset is randomly partitioned into 5 subsets, out of which 4 subsets are used to train models to identify vulnerability types and to evaluate risk levels, the last subset is used to evaluate the performance of the trained models. The performance is measured using the metric of area under the curve (AUC).

Then, we established the models by combining neural text representation techniques and ANN. When training ANN models, we set the dimension of the eigenvector to 100 and ignored words with fewer than 5 occurrences. We added a layer of Dropout to avoid overfitting. The activation function between networks is ReLU. The activation function for the last layer of the network is SoftMax, since the task is multi-categorized. We evaluate the performance of all the models in AUC.

## Vulnerability Type Identification

The performance of proposed identifiers is presented in Table 3.

Table 3: Performance of Vulnerability Type Identification

Vulnerability Type	Statistical Text & Machine Learning					Neural Text & ANN			
	LR	CART	RF	GBDT	SVM	ANN (CBOW+NS)	ANN (CBOW+HS)	ANN (SG+NS)	ANN (SG+HS)
Cross-site Scripting (XSS)	0.9656	0.8337	0.9709	0.974	0.9602	0.9835	0.9813	0.9823	0.9804
SQL Injection	0.9623	0.847	0.9632	0.9632	0.9575	0.9706	0.9722	0.9729	0.9714
Weak Password	0.9304	0.7083	0.9333	0.9296	0.923	0.9412	0.9431	0.9472	0.9431
Successful Intrusion Event	0.7929	0.5275	0.8069	0.8092	0.7858	0.8454	0.8507	0.8599	0.8569
Sensitive Information Disclosure	0.7950	0.6002	0.8236	0.8284	0.8052	0.8511	0.8514	0.8592	0.8559
File Operation Vulnerability	0.8996	0.6665	0.919	0.9171	0.8933	0.9254	0.9283	0.9299	0.938
Configuration Error	0.7981	0.5746	0.7932	0.8054	0.788	0.8221	0.8309	0.8388	0.8319
Design Defect/ Logic Error	0.8706	0.677	0.8863	0.8795	0.8700	0.9024	0.9082	0.9074	0.9068
Remote Code Execution	0.9082	0.7433	0.9299	0.9241	0.8996	0.9464	0.9459	0.9457	0.9445
Unauthorized Access/ Permission Bypass	0.8174	0.5945	0.8367	0.844	0.8224	0.8548	0.8569	0.8630	0.8574
Average	0.8740	0.6773	0.8863	0.8875	0.8705	0.9043	0.9069	0.9106	0.9086

From Table 3, the overall classification results of vulnerability types are acceptable. We find that the identification rate is high in Cross-site Scripting, SQL Injection, Weak Password, File Operation Vulnerability and Remote Code Execution. The identification performance of these types of vulnerabilities is higher or close to 90%. The average AUC classification performance for Design Defect/Logic Error is 90.68%, which is close to the average AUC for all vulnerability categories. On the other hand, the identification rate is low in Successful Intrusion Event and Configuration Error. The small sample size of these two types of vulnerabilities may be the reason for low identification rate. Follow-up studies can construct a more balanced dataset to train the identifier. In addition, the average identification performance of Sensitive Information Disclosure and Unauthorized Access/Permission Bypass is around 80%.

The relatively low classification performance of these four types of vulnerabilities may be due to the unbalance dataset and the complexity of vulnerabilities. Successful Intrusion Event includes a variety of intrusion methods, such as: intrusion of malicious files, successful intrusion due to wrong use of editing tools, etc. Various intrusion methods lead to the similarity of this



vulnerability category with other vulnerability types, thus it is difficult to identify. Configuration Error are mainly the result of improperly configured system, service operations and maintenance. Thus, it is usually exploited by attackers, since it usually involves numerous human factors or defects in the information system itself. Therefore, the variety of features results in low classification performance. Unauthorized Access/Permission Bypass means that attackers without authentication can still remote login servers. These vulnerability records usually contain illegal manipulation of databases or website directories, as well as leakage of sensitive information. Therefore, these records can also be classified as Sensitive Information Disclosure.

In the first identification model, the identification rate is relatively higher in RF and GBDT, but is lowest in CART. The identification rate of CART is 67.7%, but the identification rates of RF and GBDT are above 88%. In terms of model characteristics, it is more difficult for CART to predict continuous text. RF and GBDT improve CART by assembling weak classifiers into more powerful ones. Thus, the results of RF and GBDT are significantly improved. LR and SVM are common linear models. Their identification rates are more than 87%, slightly lower than GBDT and RF. In the second identification model, all the identification rates of each identifier are higher than 0.9. SG+NS could achieve the highest identification rate. SG could perform better than CBOW model for the reason that SG is more suitable to analyze long texts. Overall, ANN could outperform traditional machine learning models when identifying information systems vulnerabilities.

### Risk Level Prediction

Now we move our focus to evaluate the risk levels for all types of information systems vulnerabilities. The performance of risk level prediction is presented in Table 4.

Table 4: Performance of Risk Level Prediction

Risk Level	Statistical Text & Machine Learning					Neural Text & ANN			
	LR	CART	RF	GBDT	SVM	ANN (CBOW+NS)	ANN (CBOW+HS)	ANN (SG+NS)	ANN (SG+HS)
High	0.7418	0.5794	0.7250	0.7363	0.7198	0.7417	0.7431	0.7445	0.7441
Middle	0.5914	0.5402	0.6444	0.6638	0.6340	0.6728	0.6719	0.6705	0.6715
Low	0.7532	0.5686	0.7243	0.7553	0.7351	0.7628	0.7627	0.7656	0.7727
Average	0.6955	0.5627	0.6979	0.7185	0.6963	0.7257	0.7259	0.7269	0.7294

Table 4 shows that the prediction rates of low risk level and high risk level vulnerabilities are higher than that of middle risk level vulnerabilities. The possible reason of a low prediction rate of middle risk level vulnerabilities is that its detailed description is relatively ambiguous, especially compared to those of high and low risk level vulnerabilities. Take Cross-site Scripting (XSS) as an example. There exist significant difference in the description between a high risk XSS and a low risk XSS, which are caused by poor data filtering. High risk XSS can lead to Web page hanging horse, identity theft, XSS worm attacks and so on. Some attackers utilize XSS to steal cookies, and view users' privacy. Some high risk XSSs attacks can even hijack a user's web behavior to monitor their browsing history, data they send and receive, etc. For low risk XSS, posters mostly describe the location of the vulnerability to warn companies, such as headers of logs or comments. The description of low risk vulnerabilities is significantly simpler.

On the other hand, the description of middle risk vulnerabilities is relatively ambiguous. Let's take, Baihe, an online dating platform with a large number of daily visitors, as an example. The poster described the impact of a middle risk level XSS in Baihe as: *"if the malicious code inserted, its spreading impact is still not insignificant"*. Vague description like those leads to the difficulty to define vulnerabilities in middle risk level. This may lead to a relatively lower evaluation performance.

From algorithm point view, GBDT performs better in risk level prediction. Its performance was similar to that of ANN. LR performs better when predicting low and high-risk levels. The performance of RF, GBDT and SVM in risk level prediction is more stable. In contrast, CART performs worst in risk level prediction tasks. CART has high computational complexity and is not suitable for high-dimensional sparse features. Since there exist a large number of features in our experiments, it takes a lot of time to train each regression tree. This may explain the low performance of CART.

For ANN, SG could achieve higher prediction rate than CBOW since SG is suitable to analyze long documents. Besides, HS slightly outperforms NS since HS is good at pre-training of infrequent words. Overall, ANN outperforms traditional machine learning models by about 2% in AUC score.

### CONCLUSION AND FUTURE DIRECTION

This research adopts intelligent models and various text representation techniques to comprehensively understand information systems vulnerabilities. First, we collected reports of information system vulnerabilities from a crowd-testing platform in China. Then we conducted experiments to automatically identify vulnerability types and predict their risk levels. Our experimental results show that the combination of ANN and neural text representation could outperform other state of art algorithms. Therefore, this research is of significant importance to both vulnerability literature and cyber security practice.

Vulnerability reports may include image and screenshots demonstrating codes, technical problems, among others, associated with information systems vulnerabilities. Future research could adopt image-understanding techniques to improve the performance of models to understanding vulnerabilities.

#### ACKNOWLEDGEMENT

This research is supported by grants from the National Natural Science Foundation of China (Grant 71801014) and Beijing Social Science Foundation (Grant 17GLC069). Xiong Zhang (xiongzhang@bjtu.edu.cn) is the corresponding author.

#### REFERENCES

- Ahmed, A., Deokar, A., and Lee, H. C. B. (2021). “Vulnerability Disclosure Mechanisms: A Synthesis and Framework for Market-Based and Non-Market-Based Disclosures,” *Decision Support Systems* (148). <https://doi.org/10.1016/j.dss.2021.113586>
- Grieco, G., and Dinaburg, A. (2018). “Toward Smarter Vulnerability Discovery Using Machine Learning,” *Proceedings of the ACM Conference on Computer and Communications Security*, Association for Computing Machinery, October 15, pp. 48–56. <https://doi.org/10.1145/3270101.3270107>
- Yang, H., Zhang, J. F., and Zhang, X. (2021). “Network Vulnerability and Enterprises’ Response: The Preliminary Analysis,” In Chan, Y. et al. (Eds.) *Proceedings of Twenty-Seventh Americas Conference on Information Systems (AMCIS 2021)*, Montreal, Canada, August 9-13. [https://aisel.aisnet.org/amcis2021/info\\_security/info\\_security/22](https://aisel.aisnet.org/amcis2021/info_security/info_security/22)
- Li, Q., Hao, P., Li, J. X., Xia, C., Yang, R., Sun, L., Yu, P. S., and He, L. (2022). “A Survey on Text Classification: From Traditional to Deep Learning,” *ACM Transactions on Intelligent Systems and Technology* (13:2), Association for Computing Machinery, pp. 1–41. <https://doi.org/10.1145/3495162>
- Li, Y., and Zhao, L. (2022). “Collaborating with Bounty Hunters: How to Encourage White Hat Hackers’ Participation in Vulnerability Crowdsourcing Programs through Formal and Relational Governance,” *Information and Management* (59:4). <https://doi.org/10.1016/j.im.2022.103648>
- Niu, X., Li, W., Zhang, J., Zhang, X., Chen, J., and Xu, H. (2022). “The Impact of Information Systems Vulnerability Announcements on Firms’ Market Value,” In Li, E.Y. et al. (Eds.) *Proceedings of the 22nd International Conference on Electronic Business (ICEB 2022)*, pp. 691–700. <https://aisel.aisnet.org/iceb2022/70/>
- Ransbotham, S., Fichman, R. G., Gopal, R., and Gupta, A. (2016). “Ubiquitous IT and Digital Vulnerabilities,” *Information Systems Research* (27:4), pp. 834–847. <https://doi.org/10.1287/isre.2016.0683>
- Ruohonen, J. (2017). “Classifying Web Exploits with Topic Modeling,” *Proceedings of 2017 28th International Workshop on Database and Expert Systems Applications (DEXA)* (Vol. 2017-August), IEEE, Lyon, France, September 28, pp. 93–97. <http://ieeexplore.ieee.org/document/8049693/>
- Spanos, G., Angelis, L., and Toloudis, D. (2017). “Assessment of Vulnerability Severity Using Text Mining,” in *21st Pan-Hellenic Conference on Informatics* (Vol. Part F132523), Association for Computing Machinery, September 28..
- Verizon. 2022. “DBIR Data Breach Investigations Report.” <https://www.verizon.com/business/en-gb/resources/reports/dbir/> (accessed 1 February 2023).
- Wang, T., Ulmer R. J., and Kannan, K. N. (2009). “The Association between the Disclosure and the Realization of Information Security Risk Factors,” *Information Systems Research* (24:2). <https://doi.org/10.1287/isre.1120.0437>
- Wawrzyński, A., and Szymański, J. (2021). “Study of Statistical Text Representation Methods for Performance Improvement of a Hierarchical Attention Network,” *Applied Sciences (Switzerland)* (11:13), MDPI AG. <https://doi.org/10.3390/app11136113>
- Wu, T., Chen, L., Du, G., Zhu, C., and Shi, G. (2021). “Self-Attention Based Automated Vulnerability Detection with Effective Data Representation,” *Proceedings of 2021 IEEE Intl Conf on Parallel & Distributed Processing with Applications, Big Data & Cloud Computing, Sustainable Computing & Communications, Social Computing & Networking*, New York City, NY, USA: IEEE, December 22, pp. 892–899. <https://ieeexplore.ieee.org/document/9644777>
- Zhang, X., Xie, H., Yang, H., Shao, H., and Zhu, M. (2020). “A General Framework to Understand Vulnerabilities in Information Systems,” *IEEE Access* (8), Institute of Electrical and Electronics Engineers Inc., pp. 121858–121873. <https://ieeexplore.ieee.org/document/9130665>
- Zhang, X., Shao, H., Zhu, M., and Zhang, R. (2020). “Towards Understanding Vulnerability in Information Systems: The Topic Modeling Perspective,” *Proceedings of the Twenty-Fourth Pacific Asia Conference on Information Systems (PACIS 2020)*, Dubai, UAE, June 20-24. <https://aisel.aisnet.org/pacis2020/242/>
- Xue, J., Liu, K., Lu, Z., and Lu, H. (2019). “Analysis of Chinese Comments on Douban Based on Naive Bayes,” *Proceedings of the 2nd International Conference on Big Data Technologies (ICBDT 2019)*, Association for Computing Machinery, August, pp. 121–124. <https://doi.org/10.1145/3358528.3358570>
- Ye, R., and Zhang, X. (2021). “Information Security and Firms’ Market Value: The Preliminary Analysis,” *Proceedings of the 21st International Conference on Electronic Business (ICEB 2021)*, Nanjing, China, pp. 235–243. <https://aisel.aisnet.org/iceb2021/11/>

- Yitagesu, S., Zhang, X., Feng, Z., Li, X., and Xing, Z. (2021). "Automatic Part-of-Speech Tagging for Security Vulnerability Descriptions," *Proceedings of ACM 18th International Conference on Mining Software Repositories, MSR 2021*, Institute of Electrical and Electronics Engineers Inc., May 1, pp. 29–40. <https://ieeexplore.ieee.org/document/9463114>
- Zhang, X., Tsang, A., Yue, W. T., and Chau, M. (2015). "The Classification of Hackers by Knowledge Exchange Behaviors," *Information Systems Frontiers* (17:6), Springer New York LLC, pp. 1239–1251. <https://doi.org/10.1007/s10796-015-9567-0>
- Zhang, X., and Yue, W. T. (2020). "Integration of On-Premises and Cloud-Based Software: The Product Bundling Perspective," *Journal of the Association for Information Systems* (21:6), Association for Information Systems, pp. 1507–1551. <https://aisel.aisnet.org/jais/vol21/iss6/6/>
- Zhuang, Y., Choi, Y., He, S., Leung, A. C. M., Lee, G. M., and Whinston, A. (2020). "Understanding Security Vulnerability Awareness, Firm Incentives, and ICT Development in Pan-Asia," *Journal of Management Information Systems* (37:3), Routledge, pp. 668–693. <https://doi.org/10.1080/07421222.2020.1790185>

## Investigating the Impact of AIGC Features on the Users' Perception of the Persuasiveness of AIGC: A Perspective of Two-dimensional Awe Emotions

Xibo Liu <sup>1</sup>  
Bo Yang <sup>2,\*</sup>  
Haofei Cheng <sup>3</sup>  
Yongqiang Sun <sup>4</sup>

\*Corresponding author

<sup>1</sup> Postgraduate, Wuhan University, Wuhan, China, liuxibo@whu.edu.cn

<sup>2</sup> Doctoral Student, Wuhan University, Wuhan, China, yangboo@whu.edu.cn

<sup>3</sup> Postgraduate, Wuhan University, Wuhan, China, chenghf0509@163.com

<sup>4</sup> Professor, Wuhan University, Wuhan, China, sunyq@whu.edu.cn

### ABSTRACT

The development of Artificial Intelligence (AI) continues to profoundly influence the human-intelligence interaction. As AI-Generated Content (AIGC) progressively approaches, and in some instances, even surpasses human-created content, it augments the natural human-intelligence interaction experience, offering users convenient and efficient information services. However, it also raises the issue of the users' perception of the persuasiveness of AIGC. Consequently, there is an imperative to empirically investigate the users' perception of the persuasiveness of AIGC. Drawing upon the Stimulus-Organism-Response (SOR) theory, this paper introduces two novel variables, namely positive and negative awe, to construct a comprehensive model that elucidates the factors influencing the users' perception of the persuasiveness of AIGC. To empirically test this model, we gather a dataset comprising 298 valid responses through a web-based questionnaire. We employ the Partial Least Squares Structural Equation Modeling (PLS-SEM) technique for rigorous statistical analysis. The findings of this study reveal that AIGC's cognitive and relational competencies exert a significantly positive impact on the elicitation of positive awe among users, while AIGC's cognitive and emotional competencies are associated with a significantly negative effect on the generation of negative awe among users. Furthermore, this study shows that positive awe has a notably favorable influence on the users' perception of the persuasiveness of AIGC, negative awe has a negative effect on the users' perception of the persuasiveness of AIGC. Innovatively, this paper introduces the concept of awe as a pivotal mechanism influencing the users' perceptions of the persuasiveness of AIGC. Through rigorous empirical analysis, this paper provides advice for technology companies on enhancing the users' perception of the persuasiveness of AIGC.

*Keywords:* AIGC, SOR theory, positive awe, negative awe, perception persuasiveness

### INTRODUCTION

AI-Generated Content (AIGC) refers to the use of artificial intelligence technology to generate content automatically. AIGC has greatly changed the way of thinking, behavior and life of users in this era (Paul & Dennis, 2023). With the continuous progress of artificial intelligence technology, the generation mode of AIGC is constantly developing and widely applied. Categorized by their modes of generation, AIGC products include text generation, image generation, code generation, and audio generation. At the end of 2022, OpenAI launched a famous artificial intelligence text generation product: ChatGPT. ChatGPT garnered over a million registered users within a mere five days of its release, with active users exceeding 100 million within a month. ChatGPT facilitates high-quality text generation, including the creation of articles, summaries, translations, dialogues, and more. The emergence of AIGC simplifies the process of content creation and has been widely used in the field of art. ChatGPT is an AI Natural Language Processing (NLP) model-generating AI technology applied to provide algorithmic responses to question-prompted conversations (Van et al., 2023). Developed by OpenAI, ChatGPT boasts a rich feature set and is proficient in various tasks, such as chatbot services, language translation, text generation, and even automating the preparation of academic papers like dissertations and programming code, adapting to users' personalized needs in real-time and with flexibility.

When users use AI tools to generate content, they prioritize responses that are perception of persuasiveness (Chandra, Shirish & Srivastava, 2022). However, ChatGPT often lacks the ability to incorporate new knowledge dynamically and sometimes fails to learn its experiences. It makes occasional errors of basic logic that may not seem obvious in some specialized domains, or there may be excessive trust in obtaining false results from users (Zhang et al., 2023). These limitations of AIGC can lead users to perceive it as lacking persuasiveness, thereby eliciting resistance.

Consequently, the utilization of AIGC is a double-edged sword for users. The purpose of this paper is how to play the role of AIGC and enhance the users' perception of the persuasiveness of AIGC. Users' perception of the persuasiveness of AIGC and

their willingness to use it for problem-solving are inherently tied to their perceptions and evaluations of their interactions and dialogues with AIGC. However, previous research has the following shortcomings: Firstly, there is a lack of definitive research pinpointing the critical features of AIGC that impact the users' perception of the persuasiveness of AIGC. Hence, we pose Research Question 1 (RQ1): Which features of AIGC influence the users' perception of the persuasiveness of AIGC? Secondly, there is currently a gap in understanding the intermediary mechanisms through which AIGC affects the users' perception of the persuasiveness. Consequently, we pose Research Question 2 (RQ2): What is the intermediary mechanism by which AIGC shapes the users' perception of the persuasiveness of AIGC?

The purpose of this paper is to address the previously mentioned research inquiries utilizing the framework of the Stimulus-Organism-Response (SOR) theory. Firstly, it investigates the pathways through which AIGC affects the users' perceptions of persuasiveness, leveraging the three-dimensional features of AIGC. The three-dimensional interactive features of AIGC are AIGC cognitive competency, AIGC relational competency, and AIGC emotional competency. AI cognitive, relational, and emotional competency are the three-dimensional abilities for AI tools to interact with users (Chandra, Shirish & Srivastava, 2022). Secondly, this paper posits that awe is the key mechanism by which AIGC's three-dimensional features influence the users' perceptions of persuasiveness. Specifically, users are more likely to be awed by AIGC with heightened interaction competencies (Benbasat & Wang, 2005). When AIGC demonstrates creative, spontaneous, and open handling of information problems, as well as effectively addressing user needs, users perceive it as possessing cognitive competencies, thus altering their sense of awe towards AIGC. Conversely, when AIGC prioritizes collaboration with users and displays consideration for their needs and preferences, users perceive it as having relational competencies, further affecting their sense of awe. Finally, when AIGC demonstrates humanistic care and empathy in its interactions with users, users perceive it as possessing emotional competency, thereby impacting their sense of awe towards AIGC. Individuals who experience awe are more likely to perceive persuasiveness, with the sense of obedience induced by awe playing a mediating role (Fei, Huang, & Wang, 2021). Therefore, awe, as a key user psychological mechanism, can explain how the three-dimensional characteristics of AIGC affect the users' perception of the persuasiveness of AIGC.

In summary, this paper treats the three-dimensional interaction features of AIGC as the independent variable, the users' perception of the persuasiveness of AIGC as the dependent variable, and users' positive or negative awe experience as the mediating variable of the regulatory mechanism.

## LITERATURE REVIEW

### AIGC Interaction Features

Prior studies have initially explored the effects of AIGC features on user behavior. Based on the TAM model, Liu and Ma (2023) studied the extent to which ChatGPT is perceived and utilized by EFL learners outside the classroom and believed that learners who are positive about the usefulness of ChatGPT tend to show higher levels of behavioral intentions. Prasad (2023) aims to put forth and examine the influencing factors impacting the adoption of generative AI technology by utilizing the Technology-Organization-Environment framework in conjunction with the institutional theory and the diffusion of innovation theory. Schuetzler et al. (2018) created an interaction environment similar to the human social environment and observed the user's engagement with the AIGC product in this environment. Emmerling and Boyatzis (2012) argued that appropriate algorithms for training AIGC to interact with humans also affects user engagement with AIGC products. However, prior studies examining the influence of AIGC on users' conviction have often been limited to AIGC's one-dimensional features, neglecting a holistic exploration of the impact of AIGC's three-dimensional features. In addition, no research has highlighted how AI tools might evoke positive and negative awe in users. In this paper, we will conduct a study centered on the three-dimensional interaction features of AIGC.

Cognitive competency pertains to the ability to process, store, and extract information, encompassing the capacity to comprehend the composition of entities, the interplay between performance and external factors, the dynamics of development, the direction of progression, and fundamental principles. In the text generated by AI tools, cognitive competency signifies the AI's capacity to process information, solve problems, and fulfill assigned tasks (Eschenbrenner & Nah, 2014). For example, the cognitive competency of text-based AI products can be evident in tasks related to information processing, such as writing proficiency.

Relational competency involves the aptitude to communicate and collaborate with others to cultivate and sustain harmonious interpersonal connections. AIGC's relational competency embodies the capability of AI products to interact with users, including supporting cooperative engagement among users (Wang & Haggerty, 2011). For example, ChatGPT can engage with users to discern their preferences and cater to their individual requirements.

Emotional competency, as the third pivotal competency, pertains to the capacity to empathize with and interact effectively with others (Pittenger, 2015). AI emotional competency signifies the AI's ability to endeavor to understand users' emotions, feelings, and responses, regulate its own emotional expression, articulate its own emotions, and establish an appropriate emotional rapport with users. For example, certain voice recognition software can discern a customer's emotional state during a phone conversation, enabling real-time adjustment of its dialogue with the user.

### Awe

Awe is a complex emotional experience characterized by wonder that arises when individuals encounter something magical or elusive, which cannot be fully comprehended within existing cognitive models (Griskevicius, Shiota, & Neufeld, 2010). In terms of the intensity of awe as an emotion, most scholars consider it to be a positive emotional state (Stellar et al., 2015). However, some scholars argue that awe may encompass negative attributes. They contend that latent fear is one of the four characteristics of awe, that the ten elements of the awe experience include elements of fear (Bonner & Friedman, 2011), and that awe can also be based on a sense of threat, referred to as "negative awe" (Gordon et al., 2017). Recent research has confirmed the existence of two types of awe emotions with varying intensities: positive and negative awe emotions (Vohs & Schmeichel, 2003). This paper maintains that the original concept of awe includes notions of relative status and the associated hierarchical relationships, which can assist individuals of lower status in adapting their cognitive and behavioral patterns to accommodate their subordinate positions and integrate into a group. Hence, the negative aspects of awe cannot be disregarded. From the perspective of both positive and negative awe, this paper explores the influence of awe on the perceived persuasiveness of AIGC.

Prior studies on the impact of positive and negative emotions on persuasiveness have suggested that individuals in positive emotional states are more susceptible to heuristic prompts, while those in negative states are less inclined to employ such cognitive shortcuts (Tiedens & Linton, 2001). Given that awe is a complex emotion with both positive and negative attributes, it warrants an in-depth examination of its impact on persuasiveness effects. Additionally, Ye and Zhou (2019) proposed that awe can induce systematic processing in individuals, but it also makes consumers more susceptible to advertising messages. The underlying mechanism by which awe influences persuasiveness remains unclear. Ye and Zhou (2019) suggested that awe positively impacts advertising effectiveness, but they did not explicitly elucidate the mediating mechanism of this effect.

Awe is not limited to domains like psychology and socialization, it also plays a significant role in explaining the acceptance of various AI domains, such as virtual and augmented reality (Chirico & Gaggioli, 2019). Users who choose to engage with automation in various forms (AI, voice assistants, virtual reality, mixed reality, etc.) often experience awe towards the technology. AI-enabled services are reshaping and enhancing the customer experience through emotional engagement (Huang, Rust & Maksimovic, 2019). Prior studies on the effects of awe on persuasiveness have often blurred the distinctions between different intensities of awe, thereby neglecting the differences in conclusions between positive and negative awe. Therefore, this paper will investigate the persuasiveness effects of both positive and negative awe.

#### **Stimulus-Organism-Response (S-O-R) Model**

Mehrabian and Russell (1974) introduced the Stimulus-Organism-Response (S-O-R) model, which posits that environmental signals, acting as stimuli, give rise to a multitude of emotional and cognitive responses. These responses, in turn, contribute to the formation of innovative user behavioral insights and evaluations. The S-O-R model has found widespread application across various online environments (Sharma et al., 2021). Within the S-O-R model framework, environmental cues function as external stimuli, while the anticipatory organism acts as a mediating structure between the stimulus and the response, emphasizing its impact on the user's mental processes. This paper adopts the S-O-R model to investigate the AIGC interaction features (stimuli) and their role in engendering awe-inspiring experiences (organisms), ultimately influencing the users' perception of the persuasiveness of AIGC (responses).

#### **RESEARCH MODEL AND HYPOTHESIS**

Based on the preceding analysis (refer to Figure 1), this paper presents the following research model: The independent variables consist of the three-dimensional interaction features of AIGC, namely, AIGC cognitive competency, AIGC relational competency, and AIGC emotional competency. The dependent variable is the users' perception of the persuasiveness of AIGC. The mediating variables, which play a crucial role in mediating the relationship between AIGC interaction features and the users' perception of the persuasiveness of AIGC, are the positive awe and negative awe experienced by users in response to AIGC. From a mediator perspective, it is suggested that AIGC interaction features impact the generation of both positive and negative awe among users in their interactions with AIGC. Consequently, this influence extends to the users' perception of the persuasiveness of AIGC. In summary, the central research question addressed in this paper pertains to how AIGC interaction features influence the users' perception of the persuasiveness of AIGC by shaping their experiences of positive awe and negative awe.

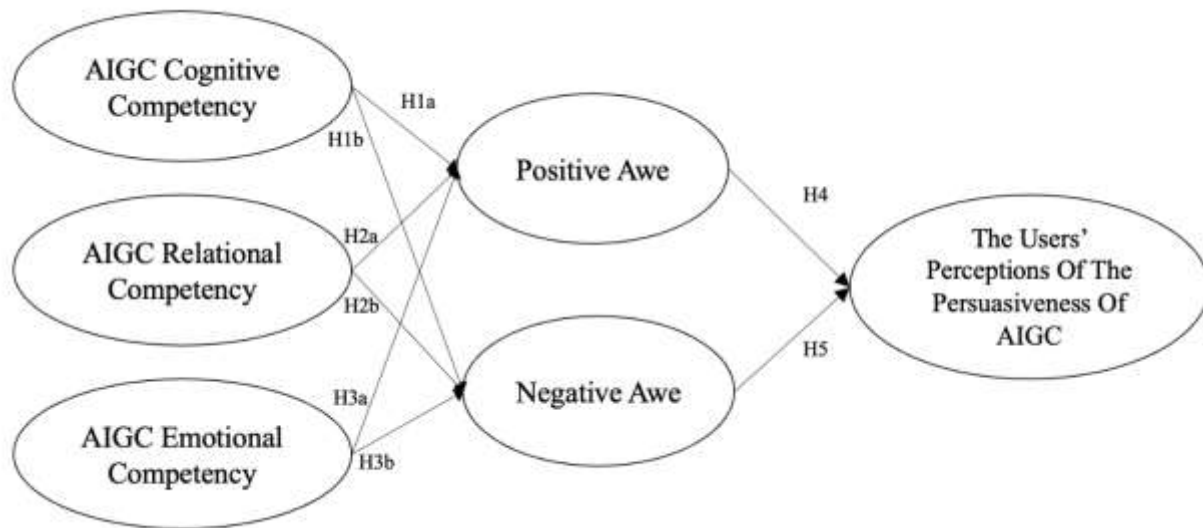

Figure 1: Research model.

### AIGC Cognitive Competency

Cognitive competency pertains to the capacity for processing, storing, and extracting information. It encompasses the ability to comprehend the composition of objects, the interrelation of attributes, the dynamics of development, the direction of progress, and the fundamental principles governing phenomena. Within the context of an AIGC, cognitive competency denotes the capability to process information, resolve problems, and effectively carry out assigned tasks. Prior research has posited that the cognitive competency of AI can influence the user's sense of awe (Kautish et al., 2023). When an AIGC adeptly addresses information challenges, displays spontaneity in problem-solving, and operates transparently in meeting user needs, users perceive it as possessing cognitive prowess and adeptness in executing designated tasks, thereby altering their awe toward the AIGC.

The manifestation of cognitive competencies by AIGC enhances users' evaluations of its products and fosters user confidence in relying on AIGC. Consequently, this paper anticipates that AIGC's cognitive competencies will elevate users' positive awe experiences while diminishing negative awe sentiments. Users are inclined to cede control and delegate tasks to the AIGC, thereby reducing their cognitive exertion in overseeing AIGC performance. Accordingly, this paper formulates the following hypotheses:

*H1a: AIGC cognitive competency significantly positively influences the generation of users' positive awe.*

*H1b: AIGC cognitive competency significantly negatively influences the generation of users' negative awe.*

### AIGC Relational Competency

Relational competency pertains to the aptitude for effective communication and collaboration with others to foster and sustain harmonious interpersonal relationships. In the context of AIGC, its relational competency denotes the capability of AI products to engage users in cooperative interactions, including supporting users in collaborating with one another (Wang & Haggerty, 2011). For instance, ChatGPT can engage users in conversations to discern their preferences and fulfill their individualized requirements. Kautish et al. (2023) argue that the relational competency of AI can significantly influence the user's experience of awe. When an AIGC prioritizes collaboration with users and demonstrates attentiveness to their needs and preferences, users perceive it as possessing interpersonal, or relational, competencies. This perception, in turn, alters their sense of awe toward the AIGC. To users, a relationally competent AIGC that exhibits qualities like attentiveness, cooperation, and fairness fosters a stronger bond between the AIGC and its interacting users. This increased intimacy helps reduce communication ambiguity and disconnection (Biocca, Harms & Burgoon, 2003). Consequently, this paper posits that AIGC's relational competency will amplify positive awe and diminish negative awe among users in relation to AIGC products. Therefore, this paper formulates the following hypotheses:

*H2a: AIGC relational competency significantly positively influences the generation of positive awe in users.*

*H2b: AIGC relational competency significantly negatively influences the generation of negative awe in users.*

### AIGC Emotional Competency

Emotional competency, which ranks as the third most critical competence, pertains to the ability to empathize with and interact effectively with others (Pittenger, 2015). In the context of AI, emotional competency refers to AI's capacity to attempt understanding users' emotions, feelings, and reactions, to regulate its own emotional expression, to convey its emotions, and to establish an emotional connection with users in an appropriate manner. For instance, certain voice recognition software can discern a customer's emotional state during a phone call and subsequently adjust its dialogue with the user in real-time. AIGC systems endowed with emotional competencies provide a human-like sense of warmth and empathy, thereby creating a simulated interpersonal environment. This heightened sense of presence imparts a natural and realistic impression of the AIGC to the user, resulting in sustained emotional engagement and excitement. Kautish et al. (2023) contend that the emotional competencies of AI can significantly influence the user's experience of awe. When an AIGC demonstrates humanistic care and empathy during interactions with users, maintains real-time emotional connections, and satisfies users' emotional needs with human-like warmth



and sympathy, users perceive it as possessing emotional competencies. This, in turn, alters their sense of awe toward the AIGC. Consequently, this paper posits that AIGC's emotional competency leads to an increase in positive awe and a decrease in negative awe among users in relation to AIGC products. Therefore, this paper formulates the following hypotheses:

*H3a: AIGC emotional competency significantly positively influences the generation of positive awe in users.*

*H3b: AIGC emotional competency significantly negatively influences the generation of negative awe in users.*

### **Awe**

Awe is an emotion, representing a complex emotional experience of wonder that emerges when an individual encounters something magical or elusive, beyond the grasp of existing cognitive models (Griskevicius, Shiota, & Neufeld, 2010). Recent scholarly work has confirmed the existence of two distinct types of awe emotions with varying intensities: positive awe emotions and negative awe emotions. Prior research on the influence of positive and negative emotions on persuasiveness has indicated that individuals in positive affective states are more amenable to persuasion through heuristic prompts, whereas those in negative states are less inclined to utilize such cognitive shortcuts (Tiedens & Linton, 2001). This paper posits that individuals experiencing positive awe are more susceptible to persuasion, while those in a state of negative awe are less so. The rationale behind this assertion is that research on the interplay of emotion and cognitive processing modes has shown that individuals in a negative mood tend to exhibit a more positive attitude when presented with a strong argument. Conversely, when confronted with a weak argument, they scrutinize it in search of its inadequacies (Bless et al., 1990). Individuals in a pleasant mood are more likely to be persuaded, regardless of the argument's strength. This is because individuals in a pleasurable mood tend to employ a simplified heuristic processing model, wherein the quantity of the argument suffices, regardless of its quality. This paper anticipates that individuals in a positive awe mood will display a heightened sense of compliance and will be more easily persuaded by AIGC. Conversely, individuals in a negative awe mood are expected to exhibit resistance and be less susceptible to persuasion by AIGC. Therefore, this paper formulates the following hypotheses:

*H4: Positive user awe has a significant positive effect on the users' perception of the persuasiveness of AIGC.*

*H5: Negative user awe has a significant negative effect on the users' perception of the persuasiveness of AIGC.*

## **METHOD**

### **Data Collection**

Online surveys have become a primary research tool in empirical studies within the social sciences. In recent years, the use of online survey methodologies has become increasingly prevalent in perception-related studies. Utilizing this research approach enables the prompt and efficient capture of user experiences with AIGC products. Given the nature of this research, the online survey method is highly suitable for testing the research model.

The questionnaire was distributed and collected using Credamo, an online data collection platform. A total of 359 questionnaires were randomly disseminated through the data mart. After filtering out erroneous and contradictory data from the bait questions, 298 valid questionnaires related to AIGC products were obtained, resulting in an effective response rate of 83.0%. This empirical study comprised 20 measurement items, and the quantity of valid questionnaire data satisfied the sample size requirements for the survey. Descriptive statistics of the valid samples are presented in Table 1. Among the randomly recruited adult users, 46.98% were male and 53.02% were female. The majority of respondents were aged 31 years and above, constituting 48.32% of the sample. The predominant educational background was undergraduate degrees from universities, accounting for 68.79%. Overall, usage frequency was relatively high, with 56.17% of users utilizing the platform at least once daily.

All constructs in this study were measured using scales established in previous studies and slightly adjusted to fit the research context. Specifically, AIGC cognitive competence (e.g., During my interaction with the AIGC tool, I found the AIGC tool to be myopic/open-minded) was measured with items adapted from (Chandra, Shirish& Srivastava, 2022). AIGC relational competence (e.g., During my interaction with the AIGC tool, I found the AIGC tool to be inconsiderate /considerate) was measured with items adapted from (Chandra, Shirish& Srivastava, 2022). AIGC relational competence (e.g., During my interaction with the AIGC tool, I found the AIGC tool to be insensitive/compassionate) was measured with items adapted from (Chandra, Shirish& Srivastava, 2022). Positive awe (e.g., This AIGC tool has thrilled me from the very beginning) was measured with items adapted from (Arghashi, 2022). Negative awe (e.g., This AIGC tool makes me fear for my job safety) was measured with items adapted from (Lv, Huang & Huang, 2023). The users' perceptions of the persuasiveness of AIGC (e.g., The contents generated by AIGC tool are convincing) was measured with items adapted from (O'Keefe, 2020). All items were rated on a seven-point Likert scale (1 = strongly disagree, 7 = strongly agree).

Table 1: Demographics.

Variables	Category	Frequency	Percentage(%)
Gender	Male	140	46.98
	Female	158	53.02
Age	Under20	6	2.01
	21-25	47	15.77
	26-30	101	33.89

	Above31	144	48.32
Education	College and below	41	13.76
	Bachelor's degree	205	68.79
	Master's degree	49	16.44
	PhD degree	3	1.01
Frequency of AIGC utilization	Every few hours	57	19.13
	At least once a day	112	37.58
	At least once a week	108	36.24
	At least once a month	20	6.71

### DATA ANALYSIS

Given the relatively small sample size and the data's departure from the normal distribution assumption of conventional statistical methods, we opted for the use of Partial Least Squares (PLS) as the statistical approach. Smart PLS offers a broad range of scalable causal modeling functions, making it particularly well-suited for handling small data samples. Therefore, PLS was chosen in this paper to assess the validity of the measures and test the research hypotheses, with Smart PLS 2.0 serving as the primary analytical tool.

#### Measurement Model

The mean value, standard deviation, reliability and validity tests of the measurement model are shown in Table 2. In this table, the Composite Reliability (CR) for each construct exceeds 0.7, indicating strong composite reliability for the scale. Additionally, the Average Variance Extracted (AVE) values for all variables are above 0.5, demonstrating robust convergent validity. Furthermore, as observed in Table 2, the square root of the AVE for each construct surpasses the corresponding correlation coefficients, providing evidence of excellent discriminant validity in the model.

Table 2: Descriptive statistics, reliabilities, and correlations.

Construct	MEAN	SD	AVE	CR	CC	RC	EC	PA	NA	PP
CC	5.554	1.407	0.561	0.834	<b>0.749</b>					
RC	5.916	0.888	0.535	0.775	0.409	<b>0.732</b>				
EC	5.744	1.107	0.536	0.77	0.5	0.54	<b>0.732</b>			
PA	5.914	0.907	0.535	0.775	0.476	0.515	0.385	<b>0.731</b>		
NA	2.900	1.806	0.813	0.956	-0.344	-0.314	-0.404	-0.157	<b>0.902</b>	
PP	6.001	0.856	0.529	0.768	0.417	0.517	0.533	0.394	-0.338	<b>0.728</b>

Notes: CC=AIGC Cognitive Competency; RC=AIGC Relational Competency; EC=AIGC Emotional Competency; PA=Positive Awe; NA=Negative Awe; PP= The Users' Perception Of The Persuasiveness of AIGC

Distinguishing validity, in essence, assesses whether there are low correlations and significant differences between constructs. This aspect of validity can be evaluated by comparing the correlation coefficients among the constructs with the square root of the Average Variance Extracted (AVE). As can be seen from the results in Table 3, the square root of the AVE value for each construct should be greater than the correlation between the particular and all other constructs.

Table 3: Cross-loadings.

	CC	RC	EC	PA	NA	PP
CC1	<b>0.836</b>	0.255	0.319	0.326	-0.298	0.308
CC2	<b>0.74</b>	0.243	0.452	0.29	-0.326	0.353
CC3	<b>0.818</b>	0.234	0.356	0.387	-0.232	0.308
CC4	<b>0.574</b>	0.486	0.361	0.412	-0.167	0.272
RC1	0.197	<b>0.758</b>	0.401	0.373	-0.238	0.412
RC2	0.393	<b>0.715</b>	0.424	0.389	-0.252	0.355
RC3	0.303	<b>0.721</b>	0.357	0.367	-0.195	0.369
EC1	0.35	0.448	<b>0.827</b>	0.278	-0.367	0.396

EC2	0.245	0.366	<b>0.524</b>	0.29	-0.149	0.387
EC3	0.48	0.376	<b>0.806</b>	0.29	-0.334	0.4
PA1	0.271	0.408	0.281	<b>0.696</b>	0.026	0.226
PA2	0.388	0.354	0.276	<b>0.712</b>	-0.215	0.338
PA3	0.375	0.374	0.287	<b>0.783</b>	-0.135	0.292
NA1	-0.33	-0.292	-0.323	-0.12	<b>0.895</b>	-0.322
NA2	-0.32	-0.26	-0.34	-0.172	<b>0.91</b>	-0.298
NA3	-0.319	-0.27	-0.387	-0.106	<b>0.908</b>	-0.287
NA4	-0.243	-0.287	-0.367	-0.134	<b>0.881</b>	-0.273
NA5	-0.333	-0.304	-0.4	-0.175	<b>0.916</b>	-0.339
PP1	0.332	0.453	0.455	0.336	-0.307	<b>0.83</b>
PP2	0.369	0.373	0.343	0.291	-0.241	<b>0.741</b>
PP3	0.187	0.282	0.366	0.219	-0.168	<b>0.592</b>

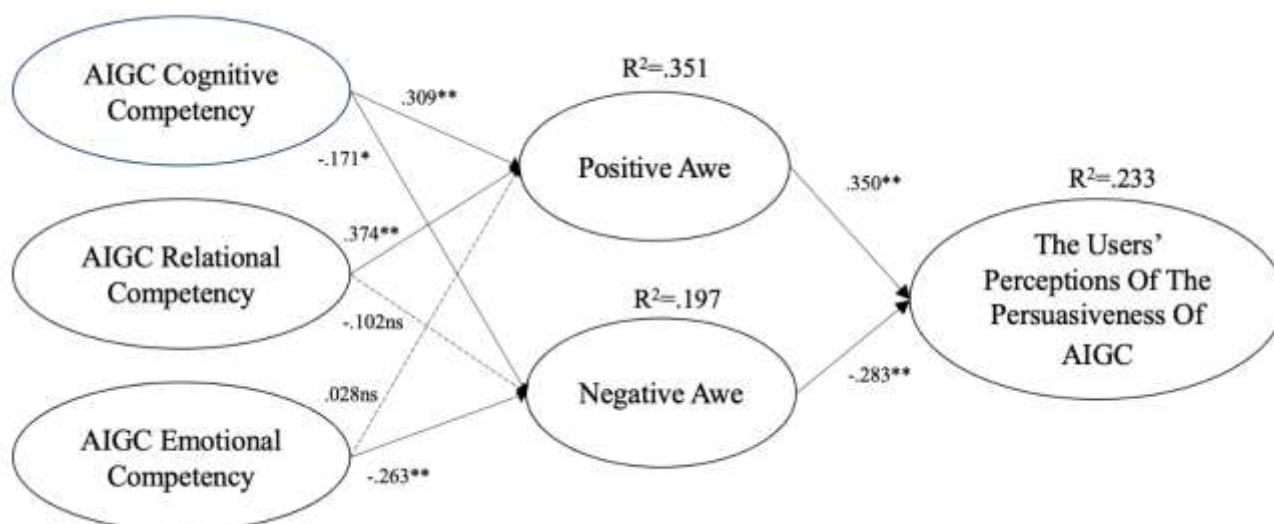

Notes : \* :  $p < .05$ , \*\* :  $p < .01$   
 Figure 2: Results of Structural Model.

### STRUCTURAL MODEL

The PLS results of the structural model are presented in the figure 2. In this paper, model testing is conducted using Bootstrapping technique to validate the causal relationship between the variables, Bootstrapping test is used to determine the significance of the relationship based on the magnitude of the T Statistics value. AIGC cognitive competency has a significant positive effect on positive awe ( $\beta = 0.309$ ,  $t = 3.821$ ,  $p < 0.01$ ), while AIGC cognitive competency has a significant negative effect on negative awe ( $\beta = -0.171$ ,  $t = 2.188$ ,  $p < 0.05$ ), supporting H1a and H1b. AIGC relational competency has a significant positive effect on positive awe ( $\beta = 0.374$ ,  $t = 5.895$ ,  $p < 0.01$ ), supporting H2a. AIGC relational competency has no significant negative effect on negative awe ( $\beta = -0.102$ ,  $t = 1.367$ ), not supporting H2b. AIGC emotional competency has no significant positive effect on positive awe ( $\beta = 0.028$ ,  $t = 0.400$ ), not supporting H3a. AIGC emotional competency has a significant negative effect on negative awe ( $\beta = -0.263$ ,  $t = 3.305$ ,  $p < 0.01$ ), supporting H3b. Furthermore, Positive awe has a significant positive effect on the users' perception of the persuasiveness of AIGC ( $\beta = 0.350$ ,  $t = 5.325$ ,  $p < 0.01$ ), supporting H4. Negative awe has a significant negative effect on the users' perception of the persuasiveness of AIGC ( $\beta = -0.283$ ,  $t = 5.585$ ,  $p < 0.01$ ), supporting H5. Overall, this research model explains 35.1% of the variance in positive awe, 19.7% of the variance in negative awe, and 23.3% of the variance in the users' perception of the persuasiveness of AIGC.

### DISCUSSION

This paper aims to explore the relationship between AIGC features, positive and negative awe, and the users' perception of the persuasiveness of AIGC. The paper also takes an innovative approach by incorporating awe as a significant factor influencing the users' perception of the persuasiveness of AIGC within the traditional S-O-R model. The conclusions drawn in this study are

based on a comprehensive process involving literature review, questionnaire design, data collection, statistical analysis, model fitting, and hypothesis testing.

First, both the cognitive and relational competencies of AIGC have a significant and positive impact on positive awe. This suggests that AIGC's cognitive and relational competencies can directly influence the positive awe experienced by users during interactions with AIGC. On one hand, AIGC's extensive data processing capabilities enable it to excel in handling general knowledge questions. On the other hand, some AIGC models exhibit satisfactory attitudes during interactions after model adjustments.

Second, both the cognitive and emotional competencies of AIGC significantly mitigate negative awe. This implies that the current state of AIGC modeling does not trigger concerns about the technology threatening human existence. For instance, AIGC occasionally provides incorrect answers to simple math questions, leading to doubts about its cognitive competence. Similarly, in everyday interactions with AIGC, it often fails to accurately gauge the user's mood from the context, which does not create a sense of threat for users.

Third, AIGC's relational competency does not significantly impact negative awe. This may be due to occasional weaknesses in AIGC's interpersonal skills during users' interactions, making it challenging for users to assess the human-like qualities of AIGC. Likewise, AIGC's emotional competency does not have a significant effect on positive awe, potentially because AIGC's ability to empathize is limited, making it difficult to accurately discern users' emotional fluctuations during conversations.

Fourth, positive awe significantly enhances the users' perception of the persuasiveness of AIGC, indicating that users' positive awe emotions during interactions with AIGC influence their behavior. In a relaxed state, users tend to accept certain ideas as correct, employing a simple heuristic processing model (Griskevicius, Shiota, & Neufeld, 2010). Conversely, negative awe significantly diminishes the users' perception of the persuasiveness of AIGC. When faced with AIGC that was clearly less competent, individuals tend to regard it as a way to acquire knowledge, rather than feel threatened by the right to know. However, some test participants did experience negative awe while interacting with AIGC, which altered their behavior. Confronted with AIGC possessing significantly superior knowledge abilities, users tended to scrutinize the dialogue provided by AIGC, reluctant to trust its extensive knowledge capabilities.

### **Theoretical Implications**

This paper extends previous research around the users' perception of the persuasiveness of AIGC in the following ways. First, past studies by scholars on the users' perception of the persuasiveness of AIGC have often focused on the instrumental value of AIGC, while mostly ignoring the interaction between AIGC and users. This paper fills this gap by building on past research, investigating AIGC based on its three-dimensional interaction characteristics, adding awe as a mediating variable, and exploring its intrinsic mechanism using the S-O-R model. This paper motivates future research to further explore the mechanisms by which the interaction features of AIGC influence the users' perception of the persuasiveness of AIGC.

Second, the use of awe as a mediating factor influencing the users' perception of the persuasiveness of AIGC is a novel contribution of this paper, which categorizes awe factors into positive and negative awe and provides new insights into how the three-dimensional interaction characteristics of AIGC influence the users' perception of the persuasiveness of AIGC. Prior studies on persuasion effects have blurred the different potencies of awe, and the differences in conclusions under positive versus negative awe moods have not been examined. This paper fills this gap, and the results suggest that users' positive and negative awe of AIGC products have different effects on the users' perception of the persuasiveness of AIGC. This implies that future research could further discuss the effects of different awe emotions on persuasiveness.

Finally, this paper empirically examines the effect of AIGC's interaction features on the users' perception of the persuasiveness of AIGC, opening up a new direction for research on perception persuasiveness. Our study shows that the three-dimensional interaction features of AIGC affect the users' perception of the persuasiveness of AIGC by changing users' positive awe or negative awe of the AIGC product. This finding provides an insight for future researchers that the value of interaction with users and users' emotions of AIGC products, in addition to the instrumental value of the product itself, can have a significant impact on the users' perception of the persuasiveness of AIGC.

### **Practical Implications**

With the increasingly fierce competition in the AIGC market, developers are striving to enhance the persuasive nature of AIGC by refining the way AIGC interacts with users. This effort aims to enhance the user experience, bolster the reputation of AIGC products, and increase user adoption intentions. Based on our survey and research, we propose two recommendations for the advancement of AIGC technology.

AIGC developers can enhance the emotional and relational competencies embedded within AIGC algorithms. Our empirical analysis reveals that users are positively influenced by AIGC when they clearly perceive its robust cognitive and relational competencies during interactions. This heightened perception of AIGC's competencies tends to evoke positive awe in users, making them perceive persuasiveness of AIGC.

AIGC developers can refine the tone and demeanor of AIGC models across diverse contexts as they undergo updates and iterations. When users find themselves in a more comfortable and positive emotional state, they become more inclined to embrace AIGC, thereby augmenting the users' perception of the persuasiveness of AIGC.

### Limitations and Future Research

This paper has some limitations. Firstly, the data is derived from user self-reports collected by Credamo, which may introduce issues related to common methodology bias. Therefore, future studies could gather objective data from users of social network platforms to validate the research model. Secondly, this paper primarily examines how AIGC interaction features influence the users' perception of the persuasiveness of AIGC by affecting their positive or negative awe. Future research could explore the variations in users' awe responses and perception persuasiveness when using different AIGC products, taking into account potential differences among these products. Lastly, the sample size in this paper is relatively small, and the surveyed participant groups are not categorized. Subsequent investigations could target specific groups, such as scientific researchers or employees of internet-based enterprises.

### ACKNOWLEDGMENT

The work described in this paper was partially supported by the grants from the Major Projects of Ministry of Education Humanities and Social Sciences Key Research Base (Project No. 22JJD870002), and the National Natural Science Foundation of China (Project No. 71974148, 71904149, 71921002).

### REFERENCES

- Paul, J., Ueno, A., & Dennis, C. (2023). ChatGPT and consumers: Benefits, pitfalls and future research agenda. *International Journal of Consumer Studies*, 47(4), 1213-1225. <https://doi.org/10.1111/ijcs.12928>
- Van Dis, E. A., Bollen, J., Zuidema, W., van Rooij, R., & Bockting, C. L. (2023). ChatGPT: five priorities for research. *Nature*, 614(7947), 224-226. <https://doi.org/10.1038/d41586-023-00288-7>
- Chandra, S., Shirish, A., & Srivastava, S. C. (2022). To be or not to be... human? Theorizing the role of human-like competencies in conversational artificial intelligence agents. *Journal of Management Information Systems*, 39(4), 969-1005. <https://doi.org/10.1080/07421222.2022.2127441>
- Benbasat, I., & Wang, W. (2005). Trust in and adoption of online recommendation agents. *Journal of the Association for Information Systems*, 6(3), 4.
- Fei, X.Z., Huang, X., & Wang, Y.W. (2021). Does awe make people obedient? —The Persuasive Role of Awe on Individuals[J]. *Nankai Management Review*: 1-24. (in Chinese).
- Schuetzler, R. M., Giboney, J. S., Grimes, G. M., & Nunamaker Jr, J. F. (2018). The influence of conversational agent embodiment and conversational relevance on socially desirable responding. *Decision Support Systems*, 114, 94-102. <https://doi.org/10.1016/j.dss.2018.08.011>
- Emmerling, R. J., & Boyatzis, R. E. (2012). Emotional and social intelligence competencies: cross cultural implications. *Cross Cultural Management: An International Journal*, 19(1), 4-18. <https://doi.org/10.1108/13527601211195592>
- Eschenbrenner, B., & Nah, F. F. H. (2014). Information systems user competency: A conceptual foundation. *Communications of the Association for Information Systems*, 34(1), 80. <https://doi.org/10.17705/1CAIS.03480>
- Wang, Y., & Haggerty, N. (2011). Individual virtual competence and its influence on work outcomes. *Journal of management information systems*, 27(4), 299-334. <https://doi.org/10.2753/MIS0742-1222270410>
- Pittenger, L. M. (2015). Emotional and social competencies and perceptions of the interpersonal environment of an organization as related to the engagement of IT professionals. *Frontiers in Psychology*, 6, 623. <https://doi.org/10.3389/fpsyg.2015.00623>
- Stellar, J. E., John-Henderson, N., Anderson, C. L., Gordon, A. M., McNeil, G. D., & Keltner, D. (2015). Positive affect and markers of inflammation: discrete positive emotions predict lower levels of inflammatory cytokines. *Emotion*, 15(2), 129. <https://doi.org/10.1037/emo0000033>
- Bonner, E. T., & Friedman, H. L. (2011). A conceptual clarification of the experience of awe: An interpretative phenomenological analysis. *The Humanistic Psychologist*, 39(3), 222-235. <https://doi.org/10.1080/08873267.2011.593372>
- Gordon, A. M., Stellar, J. E., Anderson, C. L., McNeil, G. D., Loew, D., & Keltner, D. (2017). The dark side of the sublime: Distinguishing a threat-based variant of awe. *Journal of Personality and Social Psychology*, 113(2), 310. <https://doi.org/10.1037/pspp0000120>
- Vohs, K. D., & Schmeichel, B. J. (2003). Self-regulation and extended now: Controlling the self alters the subjective experience of time. *Journal of Personality and Social Psychology*, 85(2), 217. <https://doi.org/10.1037/0022-3514.85.2.217>
- Tiedens, L. Z., & Linton, S. (2001). Judgment under emotional certainty and uncertainty: the effects of specific emotions on information processing. *Journal of Personality and Social Psychology*, 81(6), 973. <https://doi.org/10.1037/0022-3514.81.6.973>
- Ye, W.L., & Zhou, X.Y. (2019). Why can a sense of awe bring benefits to individuals and organizations?. *Tsinghua Management Review*, (6), 52-58. (in Chinese).
- Chirico, A., & Gaggioli, A. (2019). When virtual feels real: Comparing emotional responses and presence in virtual and natural environments. *Cyberpsychology, Behavior, and Social Networking*, 22(3), 220-226. <https://doi.org/10.1089/cyber.2018.0393>

- Huang, M. H., Rust, R., & Maksimovic, V. (2019). The feeling economy: Managing in the next generation of artificial intelligence (AI). *California Management Review*, 61(4), 43-65. <https://doi.org/10.1177/0008125619863436>
- Mehrabian, A., & Russell, J. A. (1974). *An approach to environmental psychology*. the MIT Press.
- Sharma, A., Dwivedi, Y. K., Arya, V., & Siddiqui, M. Q. (2021). Does SMS advertising still have relevance to increase consumer purchase intention? A hybrid PLS-SEM-neural network modelling approach. *Computers in Human Behavior*, 124, 106919. <https://doi.org/10.1016/j.chb.2021.106919>
- Kautish, P., Purohit, S., Filieri, R., & Dwivedi, Y. K. (2023). Examining the role of consumer motivations to use voice assistants for fashion shopping: The mediating role of awe experience and eWOM. *Technological Forecasting and Social Change*, 190, 122407. <https://doi.org/10.1016/j.techfore.2023.122407>
- Wang, Y., & Haggerty, N. (2011). Individual virtual competence and its influence on work outcomes. *Journal of Management Information Systems*, 27(4), 299-334. <https://doi.org/10.2753/MIS0742-1222270410>
- Biocca, F., Harms, C., & Burgoon, J. K. (2003). Toward a more robust theory and measure of social presence: Review and suggested criteria. *Presence: Teleoperators & Virtual Environments*, 12(5), 456-480. <https://doi.org/10.1016/j.techfore.2023.122407>
- Griskevicius, V., Shiota, M. N., & Neufeld, S. L. (2010). Influence of different positive emotions on persuasiveness processing: a functional evolutionary approach. *Emotion*, 10(2), 190. <https://doi.org/10.1016/j.techfore.2023.122407>
- Liu, G., & Ma, C. (2023). Measuring EFL learners' use of ChatGPT in informal digital learning of English based on the technology acceptance model. *Innovation in Language Learning and Teaching*, 1-14. <https://doi.org/10.1080/17501229.2023.2240316>
- Prasad Agrawal, K. (2023). Towards Adoption of Generative AI in Organizational Settings. *Journal of Computer Information Systems*, 1-16. <https://doi.org/10.1080/08874417.2023.2240744>
- Zhang, C., Zhang, C., Li, C., Qiao, Y., Zheng, S., Dam, S. K., ... & Hong, C. S. (2023). One small step for generative ai, one giant leap for agi: A complete survey on chatgpt in aigc era. *arXiv preprint arXiv:2304.06488*. <https://doi.org/10.48550/arXiv.2304.06488>
- Arghashi, V. (2022). Shopping with augmented reality: How wow-effect changes the equations!. *Electronic Commerce Research and Applications*, 54, 101166. <https://doi.org/10.1016/j.elerap.2022.101166>
- Lv, L., Huang, M., & Huang, R. (2023). Anthropomorphize service robots: The role of human nature traits. *The Service Industries Journal*, 43(3-4), 213-237. <https://doi.org/10.1080/02642069.2022.2048821>
- O'Keefe, D. J. (2020). Message pretesting using perceived persuasiveness measures: reconsidering the correlational evidence. *Communication Methods and Measures*, 14(1), 25-37. <https://doi.org/10.1080/19312458.2019.1620711>



## Legislation Trends: Latest Data Regulation Observations in the U.S.

Pei-Chuan Chang<sup>1,\*</sup>

---

\*Corresponding author

<sup>1</sup> University HEC Liège Executive Education, Management School- Liège Université, Belgium, Executive Doctorate in Business Administration (EDBA), Student, [pc.chang@changchang.com](mailto:pc.chang@changchang.com)

### ABSTRACT

As data protection is widely linked to and recognized as a national security issue, governments of the main economies (United States, European Union and China) have already implemented or are planning to implement various data protection measures. These data protection measures usually impose penalties and/or sanctions on non-complying entities; some would even disqualify the non-complying entities from the eligibility to do business in certain jurisdictions. To counter the changing picture of data protection in terms of risk management, it is vital that business managers be informed of the effective rules as well as the coming legislations of data protection. This research aims at collecting data regulation legislations in the U.S. and examining the trend of data protection policy. The research is dedicated to providing a summary of the related information to serve as an important reference for business managers.

*Keywords:* Data protection, national security, and risk management.

### INTRODUCTION

Data regulations are nowadays changing rapidly across the main economies for the need to strengthen national security. Data sharing/cooperation scheme is also widely discussed among the countries sharing similar values or of similar backgrounds. At the same time, data regulation also has its impact on the industrial and consumer aspects. In this regard, different states in the U.S. have implemented various data protection laws to address different issues.

How to adapt to the fast changing legal landscape for companies that conduct business across the borderlines has become a very challenging issue. This includes not only short-term adjustment but also long-term prediction and adaptation. This research collects recently-passed/proposed legislations, recently-issued orders and recently-rendered court decisions in the U.S. to find out the policy trend of data protection in the U.S. Following the trends of current legislations, companies would be able to better predict and address the issues that the legislators opine on in the future.

This research outlines the recent legislations in terms of data protection and relevant issues in the U.S. and the relevant states. This research does not cover previously passed and/or long-existing legislations. This research does not cover the recent legislations of all the states in the U.S.

This research is for academic and information sharing purposes only. This research does not constitute legal advice. Anyone should contact their attorney to obtain advice with respect to any particular legal matter.

### LITERATURE REVIEW

The literature review of this research covers the following topics relating to data regulation: (1) national security and data sharing scheme; (2) industrial and supply chain management; and (3) data protection for vulnerable groups (e.g., children and consumers).

First, national security and data sharing scheme. Crampton (2014) addresses the reason why data is important for national security by explaining that modern security measures increasingly rely on algorithms and biometric data to identify and monitor individuals, with big data playing a pivotal role in analyzing and interpreting the information. From the national security perspective, Dempsey & Flint (2004) state that the USA PATRIOT Act grants the FBI significant authority to issue National Security Letters or obtain court orders compelling commercial entities to disclose information. However, the U.S. still lacks a specific legal framework to regulate the use of private databases for national security purposes in a precise manner.

Second, industrial and supply chain management. Hendrick (2022) mentions that in the U.S., there are regulations in place to safeguard employee data, including the Privacy Act of 1974 and various state statutes that are applicable to private employers. The other issue is with regard to data brokers – Birckan et al. (2020) explain that data brokers are companies that collect information (e.g., consumer's personal information) from a wide variety of sources with the intent of reselling this information for various purposes. Oh et al. (2019) states that the data brokerage industry usually gives little transparency between providers and brokers/consumers so new regulations to strengthen the rights of individuals should be introduced and considered. Further, in terms of the mandatory disclosure of carbon emission, Downar et al. (2020) present that mandatory carbon disclosure can



create stakeholder pressure for firms to manage their emissions and Tomar (2023) mentions that the U.S. Environmental Protection Agency has implemented the Greenhouse Gas Reporting Program to request certain companies to report the greenhouse gas data. With regard to intellectual property, Merritt (2023) explains that acknowledging AI as inventors within the framework of patent law poses a multitude of challenges for the existing U.S. patent system.

Third, data protection for vulnerable groups. Baik (2020) mentions that California was the first state to introduce its own privacy law in June 2018 which has been seen as a benchmark that triggers other states to consider adopting consumer data protection laws. For child data protection, Nairn & Monkogol (2007) state that children's rights to privacy and protection are different from those of adults therefore it needs to be treated specifically.

### RESEARCH METHOD

This research will adopt a mixed-method approach. This research will first develop an idea from previous scholar works via literature review to predict the current and future legislation trend. After literature review, this research will then collect recent legislations passed or pending for legislators' review from different jurisdictions and categorize all the data into the following three topics (1) national security and data sharing scheme; (2) industrial and supply chain management; and (3) data protection of vulnerable groups. After the data (legislation) collection, this research will produce conclusions by bullet points on what companies having business scope in the U.S. should be aware of in order to mitigate the risks in the changing landscape of data legislation and address its internal and external risk management.

### RESEARCH STEPS

#### National Security and Data Sharing

The U.S. has not established a thorough legislation on data management in terms of national security in the year of 2023. However, it has entered into a data sharing scheme with the European Union and the United Kingdom. Other than the data sharing scheme, this research specifically notes that China has implemented several regulations on data compliance in terms of national security, one of which addresses the intra-territorial effect of extraterritorial data breach and another addresses the control of exporting data collected within China. Below presents the table detailing the said legislations:

Table 1: National Security and Data Sharing

Jurisdiction	Legislation	Detail
USA	EU-US Data Privacy Framework	The EU-US Data Privacy Framework “has the effect that personal data transfers from controllers and processors in the Union (EU) to certified organisations in the United States may take place...” (Paragraph 1(8))  “Personal data transferred from the Union to EU-US DPF organisations may be collected by U.S. authorities for national security purposes on the basis of different legal instruments, subject to specific conditions and safeguards.” (Paragraph 3.2.1.1(120)).
	UK-US Data Bridge	The full title of the UK-US Data Bridge is “UK Extension to the EU-US Data Privacy Framework”. This framework allows businesses to transfer personal data from the U.K. to U.S. organizations certified to the EU-US Data Privacy Framework and opted in to receive personal data from the UK.  “In order to provide transparency in respect of lawful requests by public authorities to access personal information, participating organizations may voluntarily issue periodic transparency reports on the number of requests for personal information they receive by public authorities for law enforcement or national security reasons, to the extent such disclosures are permissible under applicable law.” (Paragraph 16a)
China	Data Security Law	The Data Security Law is “formulated in order to regulate data processing activities, ensure data security, protect the legitimate rights and interests of individuals and organizations, and safeguard national sovereignty, security and development interests.” (Article 1)  The Data Security Law “shall apply to data processing activities and their security supervision within the territory of the People’s Republic of China. Anyone who conducts data processing activities outside the territory of the People’s Republic of China and harms the national security, public interests, or legitimate rights and interests of citizens or organizations of the People’s Republic of China will be held legally responsible in accordance with the law.” (Article 2)

	Cybersecurity Law	The Cybersecurity Law “is enacted in order to ensure network security, safeguard cyberspace sovereignty, national security, and public interests, protect the legitimate rights and interests of citizens, legal persons, and other organizations, and promote the healthy development of economic and social informatization.” (Article 1)  “This Law shall apply to the construction, operation, maintenance and use of networks within the territory of the People’s Republic of China, as well as the supervision and management of network security.” (Article 2)
	Measures for the Security Assessment of Outbound Data Transfer	“In order to regulate data export activities, protect personal information rights and interests, safeguard national security and social public interests, and promote the safe and free flow of data across borders...” (Article 1)  “These Measures shall apply to data processors who provide overseas security assessments of important data and personal information collected and generated during operations within the territory of the People’s Republic of China. If laws and administrative regulations provide otherwise, such provisions shall prevail.” (Article 2)

Source: This study.

### **Industry and Supply Chain: Employment**

There has not seen federal adoption of regulations in terms of data protection for employees or in the scenario of employment in the year of 2023. However, a few states have passed certain rules to protect employees’ data obtained by the employer or during the course of employment, and to protect employees from getting harmed by artificial intelligence. Although most states have consumer data protection laws, they do not extend to employee data protection. Below presents the table showing the relevant states and legislations:

Table 2: Industry and Supply Chain: Employment

Jurisdiction	Legislation	Detail
State of California	California Consumer Privacy Act (CCPA)	Although CCPA is aimed to protect consumers at first, it then expanded to protect employees by an amendment in 2023. CCPA now empowers job applicants, employees and workers to review the data the employers have saved on them, the purpose for, and the duration of which the data is kept.
State of New York	NYC Local Law 144	This local rule applies to the practices in New York City. NYC Local Law 144 specifically addresses the use of automated employment decision tools for screening job applicants.  This rule “prohibits employers and employment agencies from using an automated employment decision tool unless the tool has been subject to a bias audit.”

Source: This study.

### **Industry and Supply Chain: Data Vendor Management**

Currently, there seems no specific legislation on data vendor management in the year of 2023 other than the proposed Senate Bill 362 to amend California Data Broker Law which anticipates to regulate data brokers in terms of targeted advertising and impose data brokers to provide an “accessible deletion mechanism” to consumers.

However, entering into data processing agreements with vendors has become more and more critical in terms of vendor management, for various businesses. Certain states have established data privacy laws (e.g., California, Texas, and etc.) that have certain contractual requirements. Below are the common contractual requirement that the data processing agreements would include:

- (1) Identifying the type of personal data to be processed by the vendor.
- (2) Identifying the rights and obligations of the customer.
- (3) Identifying the duration of the vendor’s processing.
- (4) (CCPA-applicable) Prohibiting the vendor from selling personal data.
- (5) (CCPA-applicable) Specifying the business purpose for which the personal data is processed by the vendor.

### **Industry and Supply Chain: Emission Data Disclosure**

Currently, at the federal level, the Greenhouse Gas Reporting Program under the U.S. Environmental Protection Agency requires large greenhouse gas (GHG) emission sources to report the GHG data and other relevant information. In recent years, the U.S. Securities and Exchange Commission (“SEC”) proposed several climate disclosure rules for listed companies to follow and requested comments from the public in 2022 with a goal to enhance ESG investing.

At the state level, California passed the Senate Bill 253 (Climate Corporate Data Accountability Act) and Senate Bill 261 (Climate-Related Financial Risk Act) in September 2023, which would likely be signed into effect by California Governor Gavin Newsom. These bills require companies meeting certain thresholds to disclose the Scope 1, Scope 2 and Scope 3 emissions and to provide certain climate-related financial risk disclosures.

Below presents the table detailing the said rules and bills:

Table 3: Industry and Supply Chain: Emission Data Disclosure

<b>Jurisdiction</b>	<b>Rule/Bill</b>	<b>Detail</b>
USA	Climate-Related Disclosures by U.S. Securities and Exchange Commission	In early 2022, the SEC proposed climate disclosure rules and requested comments from the public. SEC explained that the proposed climate disclosure rules are to enhance ESG investing.
State of California	Senate Bill 253 and Senate Bill 261	Senate Bill 253 (Climate Corporate Data Accountability Act) and Senate Bill 261 (Climate-Related Financial Risk Act) were passed on September 12 and 13, 2023. The two bills will highly likely be signed by California Governor Gavin Newsom as he indicated his intention on September 17, 2023.  The Senate Bill 253 requires all companies with over US\$1 billion in annual revenue that are doing business in California to disclose its Scope 1, Scope 2 and Scope 3 emissions. Senate Bill 261 requires all companies with over US\$500 million in annual revenue that are doing business in California to prepare biennial climate-related financial risk disclosures aligned with the Task Force on Climate-related Financial Disclosures framework.

Source: This study

### **Industry and Supply Chain: AI and Intellectual Property**

Currently, there seems to be no legislation at the federal level specifically addressing AI issues. However, in early 2023, Senators Richard Blumenthal and Josh Hawley proposed a bill for a bipartisan framework of U.S. AI Act to regulate the uses and practices of AI.

While there is not yet legislation specifically governing AI, government guidelines and court precedents have provided some guidance for the uses and practices of AI in terms of intellectual property (e.g., copyright, patent, trademark, and etc.). At the state level, California took the lead as Governor Gavin Newsom issued an executive order to prepare California for the progress of artificial intelligence.

This research specifically notes that, China has promulgated the “Generative AI New Provisional Measures” to regulate the AI-related matters in the B2C (business-to-consumer) practices. It is not yet clear whether the B2B (business-to-business) practices would fall under the categories and be regulated under the “Generative AI New Provisional Measures”.

Below presents the table detailing the said legislations, cases, government guideline and state executive order:

Table 4: Industry and Supply Chain: AI and Intellectual Property

<b>Jurisdiction</b>	<b>Legislation/Case</b>	<b>Detail</b>
USA	<u>Federal bill</u>  Bipartisan Framework for U.S. AI Act	The Bipartisan Framework for U.S. AI Act was proposed by Senators Richard Blumenthal and Josh Hawley in early September 2023 and is currently under hearings as of September 15, 2023. This bill proposes to “establish a licensing regime administered by an independent oversight body”, “ensure legal accountability for harms”, “defend national security and international competition”, “promote transparency”, and “protect consumers and kids”.

	<p><u>Copyright matters</u></p> <p>Stephen Thaler v. Shira Perlmutter and The United States Copyright Office (1:22-cv-01564)</p> <p>Copyright Registration Guidance: Works Containing Material Generated by Artificial Intelligence</p> <p>Silverman v. OpenAI, Inc. (3:23-cv-03416)</p>	<p>This case signals that AI-generated work is not copyrightable and cannot be registered with the U.S. Copyright Office. Judge Beryl A. Howell stated in the opinion of this case that, “Copyright has never stretched so far, however, as to protect works generated by new forms of technology operating absent any guiding human hand, as plaintiff urges here. Human authorship is a bedrock requirement of copyright”.</p> <p>However, as AI-generated work can be produced partially by human beings and partially by AI technology, the U.S. Copyright Office issued a guidance on works containing AI-generated material. In addition, the U.S. Copyright Office published a document titled “Artificial Intelligence and Copyright” and requests for comments from the public on the four main topics: use of copyrighted works to train AI models, copyrightability of AI-generated materials, and potential copyright infringement liabilities, treatment of AI-generated outputs.</p> <p>This case is a class action brought by three writers (Sarah Silverman, Christopher Golden and Richard Kadrey) against OpenAI, Inc. and its subsidiaries, filed with the United States District Court Northern District of California San Francisco Division on July 7, 2023. The plaintiffs allege that OpenAI and its subsidiaries trained their large language models by copying massive amounts of text without licensing, therefore constituting copyright infringement against the plaintiffs.</p>
	<p><u>Patent matters</u></p> <p>Thaler v. Vidal, 43 F.4th 1207 (Fed. Cir. 2022)</p>	<p>This case was brought by Stephen Thaler, who develops AI systems and generates inventions, seeking patent protection for the AI inventions putatively made by his AI machines DABUS (Device for the Autonomous Bootstrapping of Unified Sentience). The USPTO (United States Patent and Trademark Office) rejected the applications of the AI-generated inventions on the basis that an inventor should be a natural person. The court of appeals decided in mid 2022 that the term “individual” of any invention under the Patent Act only refers to human beings.</p>
	<p><u>Trademark matters</u></p> <p>Getty Images (US), Inc. v. Stability AI, Inc. (1:23-cv-00135)</p>	<p>This case was brought by Getty Images (US), Inc. against Stability AI, Inc. in early 2023. The plaintiff alleges that the defendant infringes its trademarks as the images generated by the defendant’s AI system could cause consumer confusion. Currently, this case is still under relevant proceedings and pending judgment.</p>
State of California	Executive Order N-12-23	This executive order was signed by Governor Gavin Newsom to “prepare California for the progress of artificial intelligence”, with aims to “deploy GenAI ethically and responsibly throughout state government, protect and prepare for potential harms, and remain the world’s AI leader”.
China	Generative AI New Provisional Measures	<p>“In order to promote the healthy development and standardized application of generative artificial intelligence, safeguard national security and social public interests, and protect the legitimate rights and interests of citizens, legal persons and other organizations...” (Article 1)</p> <p>“The Measures shall apply to the use of generative artificial intelligence technology to provide services that generate text, pictures, audio, video and other content to the public within the territory of the People’s Republic of China...” (Article 2)</p>

Source: This study

With regard to data protection for consumers, at the federal level, the Privacy Act of 1974 outlines how federal agencies can collect and use the data of individuals, the Gramm-Leach-Bliley Act of 1999 requires companies that “offer consumers financial products or services like loans, financial or investment advice, or insurance” to safekeep the sensitive data and explain how it uses the data collected, and the Dodd-Frank Wall Street Reform and Consumer Protection Act of 2010 (also known as the Consumer Financial Protection Act) created the Consumer Financial Protection Bureau (“CFPB”) to ensure that consumers are educated about relevant financial products. Other than the abovementioned legislations, there seems no recent legislation passed at the federal level in terms of consumer data protection.

However, as consumer data protection has become more and more emphasized in recent years, the relevant agencies in charge of consumer protection (e.g., Federal Trade Commission (“FTC”) for general consumers and CFPB for financial consumers) have taken into account the advanced market practices and enforced the existing law to impose penalties/sanctions against violating companies.

On the other hand, at the state level, California passed a comprehensive consumer data protection law called “California Consumer Privacy Act” and amended the law by the “California Privacy Rights Act”. Texas passed the “Texas Data Privacy and Security Act” in 2023 to require companies to obtain consent necessary to process sensitive data. New York proposed the “New York Privacy Act” to impose compulsory security standards for the sharing of personal data but this bill is still under review.

Below presents the table detailing the said legislations and actions:

Table 5: Data Protection of Vulnerable Groups: Consumers

Jurisdiction	Legislation/Action	Detail
USA	FTC: Using Artificial Intelligence and Algorithms	The FTC issued comments on the use of artificial intelligence and algorithms to stress the importance for companies that process consumer data to stay transparent, to explain the decision to the consumer, and to ensure that the data and models are robust and empirically sound.
	CFPB: Consumer Financial Protection Circular 2022-04	The CFPB published the “Consumer Financial Protection Circular 2022-04” to outline that an entity’s insufficient data protection will lead to violation of the Consumer Financial Protection Act. Certain measures are recommended: multi-factor authentication, adequate password management, and timely software updates.
State of California	California Consumer Privacy Act (CCPA)	CCPA (AB 375) was passed in 2018. CCPA empowers all California consumers to review any data a company has saved on them and lists of any third party the data is shared with. Companies required to comply with CCPA does not need to be based in California or in the U.S.
	California Privacy Rights Act (CPRA)	CPRA is an amendment to CCPA, aiming to strengthen data protection for California residents and expands upon CCPA. Under CPRA, companies may only use personal data for the purpose for which it was collected and personal data should be deleted once the data has been used for the collection purpose.
State of New York	New York Privacy Act (NYPA)	New York Privacy Act was proposed as the Senate Bill S5642 in 2023 to require companies to provide information about how to de-identify personal data, impose compulsory security standards for the sharing of personal data, and to give consumers the right to obtain information regarding their personal data.
State of Texas	Texas Data Privacy and Security Act (TDPSA)	TDPSA was passed in June 2023 and to offer comprehensive consumer data privacy legal measures. TDPSA requires companies to obtain consent necessary to process sensitive data, to give notices for sale of sensitive personal data, and to recognize universal opt-out mechanisms.
	Texas Business and Commerce Code (i.e., Data Breach Notification Law)	Senate Bill 768 amended Section 521.053 of the Texas Business and Commerce Code to request any company to notify the state attorney general of a data breach affecting 250 or more Texas residents as soon as practicable and not later than 30 days and to Texas residents within 60 days.

Source: This study

### **Data Protection of Vulnerable Groups: Children**

With regard to the data protection for children, at the federal level, the Children's Online Privacy Protection Act ("COPPA") was enacted in 1998. As data protection for children is specifically paid attention to, FTC (the regulator in charge of children data protection in terms of fair trade) has become agile in enforcing the existing legislations and adaptive to the fast-changing practices of data collecting and processing.

At the state level, California passed the California Age-Appropriate Design Code Act in 2022 to promulgate online protections for children in California which prohibits the collection of a child's precise geolocation and the businesses from taking any action materially detrimental to the mental health of a child. Texas passed the Securing Children Online through Parental Empowerment Act in 2023 to protect children online by requiring relevant digital service providers to conduct age verification and to allow parental involvement.

Below presents the table detailing the said legislations:

Table 6: Data Protection of Vulnerable Groups: Children

<b>Jurisdiction</b>	<b>Legislation</b>	<b>Detail</b>
USA	Policy Statement of the Federal Trade Commission on Education Technology and the Children's Online Privacy Protection Act	The FTC issued a policy statement regarding the use of education technology and the applicability of COPPA, with a means to counter the fast growing use of education tools during the COVID-19 pandemic. The statement stipulates the following: COPPA-covered companies are prohibited from mandatory collection, can only use the collected information to provide the requested online education service, and must have procedures regarding the maintenance of confidentiality, security, and integrity of children's information.
State of California	California Age-Appropriate Design Code Act (CAADCA)	The CAADCA was passed in 2022. This law aims to promulgate online protections for children in California. It includes the following measures: prohibiting the collection of a child's precise geolocation; prohibiting businesses from taking any action materially detrimental to the physical health, mental health, or well-being of a child; and requiring data protection impact assessment before offering any online service accessible to children.
State of Texas	Securing Children Online through Parental Empowerment Act (SCOPE Act)	The SCOPE Act was passed in 2023 to secure children online through parental empowerment. The SCOPE Act requires digital service providers to conduct age verification, limit information collected from minors, impose certain content restrictions and allow parental involvement.

Source: This study

### **CONCLUSION**

Observing from the legislations, bills, actions and court cases, it can be concluded that:

- At the national level, national security is highly emphasized in terms of data collection, processing and maintenance. Western countries (e.g., the U.S., European Union and the U.K.) established data sharing schemes to support data flow across country borders. Therefore, non-Western companies will have to not only comply with its domestic regulations to collect, process and maintain data, but also provide data as required by the relevant regulations if the non-Western company has any branches in the West, while the data provided could be shared/transferred to a third-party country participating in the data sharing scheme.
- At the industry level, corporate transparency and a well-structured data collecting and maintaining system are obvious trends that any companies with branches in the U.S. may take into consideration. The topics cover employee data protection and processing, data vendor management and emission data disclosure. Another thing to consider is the changing landscape of intellectual property, for which any company may want to keep an eye on the current bills, newly passed legislations and court judgments and opinions, to secure its existing intellectual property and/or to increase its digital assets via new technology (e.g., AI).
- At the data protection for vulnerable groups level, the current trend is to protect consumers and children/minors. The protections range from the federal level to guarantee fair trade to the state level to protect vulnerable groups' personal property and mental health. It is worth noting that the listed protected groups are not exhaustive. In other words, the protected groups could extend to other vulnerable groups, like women, persons of color, LGBTQ, and persons with specific religious or political orientation. Any company that conducts businesses in the U.S. may consider taking measures in terms of data protection for various vulnerable groups in order to address the changing landscape of data protection.

In conclusion, any company which has branches in the U.S. or conducts business in the U.S. could be subject to the relevant data regulations, ranging from national level to consumer level. Compliance with data regulations of certain jurisdictions regarding data reporting is vital for the companies to operate legally in the specific jurisdiction. Keeping corporate data transparent and having a well-structured data collecting and maintaining system are important for companies to ensure the smooth business operation and avoid potential disputes from employees, vendors or securities exchanges (for listed companies). Lastly, it is very important to treat vulnerable groups' data carefully to avoid any potential sanction or enforcement from the FTC or CFPB in terms of fair trade, and to avoid potential lawsuit/monetary claims from the vulnerable groups/consumers.

## REFERENCES

- Baik, J. S. (2020). Data Privacy Against Innovation or Against Discrimination?: The Case of the California Consumer Privacy Act (CCPA). *Telematics and Informatics*, 52. DOI:10.1016/j.tele.2020.101431, [https://papers.ssrn.com/sol3/papers.cfm?abstract\\_id=3624850](https://papers.ssrn.com/sol3/papers.cfm?abstract_id=3624850)
- Birckan, G., Dutra, M. L., De Macedo, D. D. J., & Viera, A. F. G. (2020). Effects of data protection laws on data brokerage businesses. EAI, <https://eudl.eu/doi/10.4108/eai.22-7-2020.165673>
- California Legislative Information. (n.d.). *California Age-Appropriate Design Code Act*. [https://leginfo.legislature.ca.gov/faces/billTextClient.xhtml?bill\\_id=202120220AB2273](https://leginfo.legislature.ca.gov/faces/billTextClient.xhtml?bill_id=202120220AB2273)
- California Legislative Information. (n.d.). SB253. [https://leginfo.legislature.ca.gov/faces/billNavClient.xhtml?bill\\_id=202320240SB253](https://leginfo.legislature.ca.gov/faces/billNavClient.xhtml?bill_id=202320240SB253)
- California Legislative Information. (n.d.). SB261. [https://leginfo.legislature.ca.gov/faces/billNavClient.xhtml?bill\\_id=202320240SB261](https://leginfo.legislature.ca.gov/faces/billNavClient.xhtml?bill_id=202320240SB261)
- California Privacy Protection Agency. (n.d.). *California Consumer Privacy Act*. [https://cppa.ca.gov/regulations/pdf/cppa\\_act.pdf](https://cppa.ca.gov/regulations/pdf/cppa_act.pdf)
- California Privacy Protection Agency. (n.d.). *California Privacy Rights Act*. <https://cppa.ca.gov/regulations/>
- Central People's Government of the PRC. (2022, July 8). *Measures for the Security Assessment of Outbound Data Transfer*. [https://www.gov.cn/zhengce/zhengceku/2022-07/08/content\\_5699851.htm](https://www.gov.cn/zhengce/zhengceku/2022-07/08/content_5699851.htm)
- Consumer Financial Protection Bureau. (2022). *Consumer Financial Protection Circular 2022-04*. <https://www.consumerfinance.gov/compliance/circulars/circular-2022-04-insufficient-data-protection-or-security-for-sensitive-consumer-information/>
- Crampton, J. W. (2014). Collect it all: national security, Big Data and governance. *GeoJournal*, DOI 10.1007/s10708-014-9598-y. [https://papers.ssrn.com/sol3/papers.cfm?abstract\\_id=2500221](https://papers.ssrn.com/sol3/papers.cfm?abstract_id=2500221)
- Cyberspace Administration of China. (2016, November 7). *Cybersecurity Law*. [http://www.cac.gov.cn/2016-11/07/c\\_1119867116.htm](http://www.cac.gov.cn/2016-11/07/c_1119867116.htm)
- Cyberspace Administration of China. (2023, July 13). *Generative AI New Provisional Measures*. [http://www.cac.gov.cn/2023-07/13/c\\_1690898327029107.htm](http://www.cac.gov.cn/2023-07/13/c_1690898327029107.htm)
- Dempsey, J. X., & Flint, L. M. (n.d.). Commercial Data and National Security. *The George Washington Law Review*, 72(6), 1459-1502. <https://cdt.org/wp-content/uploads/publications/200408dempseyflint.pdf>
- Downar, B., Ernstberger, J., Reichelstein, S. J., Schwenen, S., & Zaklan, A. (2020). The Impact of Carbon Disclosure Mandates on Emissions and Financial Operating Performance. *ZEW - Centre for European Economic Research Discussion Paper, No. 20-038*. [https://papers.ssrn.com/sol3/papers.cfm?abstract\\_id=3693670](https://papers.ssrn.com/sol3/papers.cfm?abstract_id=3693670)
- European Commission. (2023, July). Adequacy decision for the EU-US Data Privacy Framework. [https://commission.europa.eu/system/files/2023-07/Adequacy%20decision%20EU-US%20Data%20Privacy%20Framework\\_en.pdf](https://commission.europa.eu/system/files/2023-07/Adequacy%20decision%20EU-US%20Data%20Privacy%20Framework_en.pdf)
- Executive Department State of California. (2023, September). Executive Order N-12-23. <https://www.gov.ca.gov/wp-content/uploads/2023/09/AI-EO-No.12--GGN-Signed.pdf>
- Federal Trade Commission. (n.d.). Policy Statement of the Federal Trade Commission on Education Technology and the Children's Online Privacy Protection Act. [https://www.ftc.gov/system/files/ftc\\_gov/pdf/Policy%20Statement%20of%20the%20Federal%20Trade%20Commission%20on%20Education%20Technology.pdf](https://www.ftc.gov/system/files/ftc_gov/pdf/Policy%20Statement%20of%20the%20Federal%20Trade%20Commission%20on%20Education%20Technology.pdf)
- Federal Trade Commission. (2020, April). Using Artificial Intelligence and Algorithms. <https://www.ftc.gov/business-guidance/blog/2020/04/using-artificial-intelligence-and-algorithms>
- Getty Images (US), Inc. v. Stability AI, Inc. (1:23-cv-00135). <https://storage.courtlistener.com/recap/gov.uscourts.ded.81407/gov.uscourts.ded.81407.1.0.pdf>
- Hendrickx, F. (2022). Protection of workers' personal data: General principles. *ILO Working Paper 62, International Labour Organization*. [https://papers.ssrn.com/sol3/papers.cfm?abstract\\_id=3448904](https://papers.ssrn.com/sol3/papers.cfm?abstract_id=3448904)
- Merritt, C. G. (2023). A Compulsory Solution to the Machine Problem: Recognizing Artificial Intelligence as Inventors in Patent Law. *Vanderbilt Journal of Entertainment & Technology Law*, 25(1), 211-237. <https://scholarship.law.vanderbilt.edu/jetlaw/vol25/iss1/5/>
- Ministry of Civil Affairs of the PRC, Data Security Law, <https://www.mca.gov.cn/zt/n2643/n2649/c1662004999979993356/content.html>
- Nairn, Agnes & Monkogol, Dowsiri (2007), Children and privacy online, *Journal of Direct, Data and Digital Marketing Practice*, Vol. 8, pp. 294-308, <https://link.springer.com/article/10.1057/palgrave.dddmp.4350063>
- New York City Department of Consumer and Worker Protection, NYC Local Law 144, <https://rules.cityofnewyork.us/wp-content/uploads/2023/04/DCWP-NOA-for-Use-of-Automated-Employment-Decisionmaking-Tools-2.pdf>



- New York Senate, New York Privacy Act, <https://legislation.nysenate.gov/pdf/bills/2019/S5642>
- Office of Governor Gavin Newsom, <https://www.gov.ca.gov/2023/09/06/governor-newsom-signs-executive-order-to-prepare-california-for-the-progress-of-artificial-intelligence/>
- Oh, H., Park, S., Lee, G. M., & Heo, H. (2019). Personal Data Trading Scheme for Data Brokers in IoT Data Marketplaces. *IEEE Access*, 7. <https://ieeexplore.ieee.org/document/8664564>
- Section 521.053 of the Texas Business and Commerce Code, <https://statutes.capitol.texas.gov/Docs/BC/htm/BC.521.htm#521.053>
- Securing Children Online through Parental Empowerment Act, <https://capitol.texas.gov/tlodocs/88R/billtext/pdf/HB00018F.pdf>
- Senator Richard Blumenthal & Senator Josh Hawley, <https://www.blumenthal.senate.gov/imo/media/doc/09072023bipartisanaiframework.pdf>
- Silverman v. OpenAI, Inc. (3:23-cv-03416), <https://llmlitigation.com/pdf/03416/silverman-openai-complaint.pdf>
- Stephen Thaler v. Shira Perlmutter and The United States Copyright Office (1:22-cv-01564), [https://patentlyo.com/media/2023/08/THALER-v.-PERLMUTTER-et-al-Docket-No.-1\\_22-cv-01564-D.D.C.-Jun-02-2022-Court-Docket-1.pdf](https://patentlyo.com/media/2023/08/THALER-v.-PERLMUTTER-et-al-Docket-No.-1_22-cv-01564-D.D.C.-Jun-02-2022-Court-Docket-1.pdf)
- Texas Legislature Online, Texas Data Privacy and Security Act, <https://capitol.texas.gov/BillLookup/History.aspx?LegSess=88R&Bill=HB4>
- Thaler v. Vidal, 43 F.4th 1207 (Fed. Cir. 2022), [https://cafc.uscourts.gov/opinions-orders/21-2347.OPINION.8-5-2022\\_1988142.pdf](https://cafc.uscourts.gov/opinions-orders/21-2347.OPINION.8-5-2022_1988142.pdf)
- Tomar, S. (2023). Greenhouse Gas Disclosure and Emissions Benchmarking. *European Corporate Governance Institute – Finance Working Paper, No. 818/2022*. [https://papers.ssrn.com/sol3/papers.cfm?abstract\\_id=3448904](https://papers.ssrn.com/sol3/papers.cfm?abstract_id=3448904)
- United Kingdom Government. (n.d.). UK Extension to the EU-US Data Privacy Framework. [https://assets.publishing.service.gov.uk/government/uploads/system/uploads/attachment\\_data/file/1185184/annex\\_a\\_ue-us\\_dp\\_f\\_principles.pdf](https://assets.publishing.service.gov.uk/government/uploads/system/uploads/attachment_data/file/1185184/annex_a_ue-us_dp_f_principles.pdf)
- U.S. Environmental Protection Agency, Greenhouse Gas Reporting Program, <https://www.epa.gov/ghgreporting>
- U.S. Copyright Office, Artificial Intelligence and Copyright, <https://www.copyright.gov/ai/docs/Federal-Register-Documents-Artificial-Intelligence-and-Copyright-NOI.pdf>
- U.S. Copyright Office, Copyright Registration Guidance: Works Containing Material Generated by Artificial Intelligence, [https://copyright.gov/ai/ai\\_policy\\_guidance.pdf](https://copyright.gov/ai/ai_policy_guidance.pdf)
- U.S. Securities and Exchange Commission, Climate-Related Disclosures/ESG Investing, <https://www.sec.gov/securities-topics/climate-esg>
- U.S. Securities and Exchange Commission, SEC Proposes Rules to Enhance and Standardize Climate-Related Disclosures for Investors, <https://www.sec.gov/news/press-release/2022-46>

Tabeck, P.S., & Ahuja, V. (2023). Leveraging technological innovation and retail business during pandemic times. In Li, E.Y. *et al.* (Eds.) *Proceedings of The International Conference on Electronic Business, Volume 23* (pp. 428-435). ICEB'23, Chiayi, Taiwan, October 19-23, 2023

## Leveraging Technological Innovation and Retail Businesses During Pandemic Times

Pooja Sehgal Tabeck <sup>1,\*</sup>  
Vandana Ahuja <sup>2</sup>

\*Corresponding author

<sup>1</sup> Symbiosis Institute of Business Management Noida, Symbiosis International (Deemed) University, Assistant Professor, [pooja.tabeck@sibmnoida.siu.edu.in](mailto:pooja.tabeck@sibmnoida.siu.edu.in)

<sup>2</sup> Symbiosis Institute of Business Management Noida, Symbiosis International (Deemed) University, Director & Professor, [director@sibmnoida.siu.edu.in](mailto:director@sibmnoida.siu.edu.in)

### ABSTRACT

Consumers around the world have radically changed their lifestyles and behaviour's in response to the pandemic. A slowdown in economic growth and the fear of uncertainty affected their buying habits and limited their shopping spree. While consumers restrained themselves behind the doors, due to financial uncertainty, the retail business felt the heat with a question on the survival of industry. In these unprecedented times, technological Innovations came as a boon for retailers to connect with customers and for exploring new facets of the business. Most of them have successfully leveraged technological innovation in their entrepreneurial journey. The purpose of the present research is to understand the acceptance of technology innovation among retailers during a pandemic. The authors adopted a qualitative case study methodology, data was collected from five retailers operating in different retail formats and product categories. Various technologies adopted by retailers during the pandemic scenario have been explored and discussed. The findings show that retailers faced challenges such as the closing of stores, social distancing, contactless transactions, and communication with customers. Technologies adopted by retailers to overcome these challenges include the adoption of e-platforms, websites, e-wallets, social media, and e-catalogues. The study investigates the technologies adopted by retailers during a pandemic, which emerged as the most promising way to support retail processes.

*Keywords:* Acceptance, Technology, Innovation, Retailers, Pandemic, Technological Innovation.

### INTRODUCTION

In its measures to keep the population safe from coronavirus, governments around the world have taken different measures, as there was no clear evidence available from history to fight this unique virus. Lockdown is one such measure adopted by countries where large-scale physical distancing measures and movement restrictions (WHO, 2020) are being introduced. Although lockdowns restricted the transmission of the virus, it severely impacted individuals and communities by bringing social and economic life near to stop. The world's major economies faced the consequences of lockdowns and their GDPs being sliced down (CEIC, 2020). Lockdown restrictions such as travel bans, social gatherings, and closure of non-essential shops, stay in a home affected individual consumers from their shopping spree in the traditional manner and mobility patterns which majorly affected retail businesses.

Retail is India's largest industry which contributed 10% of the country's GDP and 8% in employment. Before the lockdown 3X growth in the Indian retail industry was forecasted (Invest India, 2019) while unprecedented change due to COVID-19 put this also on hold. From daily needs to electronics, medicines to jewelry, food to apparel, end consumer is dependent upon retailers as they procure the products from them. Hence both retailers and consumers were clueless due to uncertainty.

Against this background, there is a need for more information and insights into retailers leveraging technology for survival during a pandemic. The pandemic accelerated the growth of technology adoption, for offline retailers as they were forced to shut down due to the outbreak of the virus. The unprecedented retail environment has forced retailers to strategize to best position themselves to survive and flourish (Grewal et al., 2021). This study aims to explore retailers' adoption and leveraging technology to reach customers, ensure customer movement inside stores, and hygienic and stress-free shopping experience. The focus is on technology innovations that have shown their potential to meet various operations of retailers and meet the needs of consumers. In addition to exploring retailer's adoption of technology applications, the empirical research centered on the following key research questions:

RQ 1: What are some of the major challenges for retailers to adopt technology in present times?

RQ 2: What are the different technologies adopted by retailers during the pandemic?

This study contributes to the existing literature by addressing the above-mentioned research questions. Our findings are important for researchers and practitioners as very little literature is available on technology adoption (Abed, 2021) by retailers. Retailers have always taken advantage of technology (Hopping, 2000), and in the pandemic for many of them it turns out to be a method of their survival. The remainder of this paper is organized as follows: Firstly, the authors briefly overviewed the relevant literature on technological innovations /adoption in the retail field. Thereafter it describes the research methodology and discusses the key empirical findings. Lastly, it presents the conclusions, limitations of the research, and future directions.

## LITERATURE REVIEW

### Technological Innovation in Retail

Around the globe, retail is shifting from traditional brick-and-mortar stores to multichannel or Omnichannel retailing. Technology in retail broadly includes methods tool and devices which includes communication with consumers and other stakeholders, facilitating to provision of information related to merchandise offerings. (Varadarajan et al., 2010) In the pre-pandemic scenario, different technology adoption from retailers has been perceived by customers as searching (Tyrväinen, & Karjaluoto, 2019) and experience channel rather than purchasing channel, but pandemic blurred this perception of consumers.

Adoption of new technology has been defined as a facilitator of change (Hopping, 2000). Various technologies for physical to digital stores facilitate retailers to achieve their multichannel practices and enhanced consumer experience. New technologies such as the Internet of Things, Virtual Reality, Augmented Reality, mixed reality, chatbots, and robots (Hoyer et al., 2020) transformed the shopping experience but these must be customized to the requirements of target groups and product categories. (Burke, 2002). The widely adopted in-store technologies by physical stores include digital price tags, scent machines, smart shelves (Grewal et al., 2020), mobile web, mobile applications (Souiden et al., 2019), and many more.

Innovative mobile-based technologies offer various solutions which differentiate the moment of purchase from the moment of consumption (Pantano & Priporas, 2016). Mobile applications do not require any large investments from retailers (Pantano, 2014) rather in the past they were often developed as an add-on feature to already existing physical or online stores. Mobile applications can be used by retail consumers to create a shopping list, search for the right products and prices, query retailers, compare different items, purchase items, and indulge in post-purchase activities (Dholakia et al., 2010). Even contactless payments with the help of Quick response codes (QR) can be done through mobile applications. Consumers with the help of mobile apps can purchase from anywhere and purchase products being delivered to their doorsteps. In the pandemic, the use of contactless mobile technologies i.e. automatic payment and self-checkout (Lai & Chuah, 2010) were a few of the methods adopted by retailers. During the pandemic mobile applications of various retailers offered ease of purchase and usefulness to consumers.

Immersive technologies like virtual and augmented realities help retailers stimulate consumers while they are isolated from physical stores. Further, virtual reality also helped customers to better evaluate products offered by retailers even from a remote location (Peck & Childer, 2003). It also simplified customers' interaction with traditional brands in a utilitarian and hedonic manner (Hollebeek et al., 2020) on technological platforms. Customers with high hedonic tendencies enjoyed different features of VR such as immersiveness, engagement, and pleasurable experience (Pizzi et al., 2019). In the Retail paradigm, virtual reality enhanced the shopping experience (McLean & Wilson, 2019) in an omnichannel environment with the help of displaying products, virtual trials, customer support, and new product launches (Hollebeek et al., 2020).

Augmented reality can be defined as the superposition of virtual objects on the real environment of the consumer (Faust et al., 2012). In an attempt to provide better engagement and experience to shoppers many retailers from beauty categories (Sephora), furniture (Ikea), interior decoration (Dulux) to grocers (Bigbasket) adopted various augmented reality-based features for web-based stores, mobile applications, and physical stores (Caboni & Hagberg, 2019). Further, for better engagement retailers adopted three methods namely user brand engagement which occurs between brand and user, user-user engagement happens between customers, and user bystander engagement which enables share their experience with AR on social media platforms (Scholz & Smith, 2016).

AR helped contactless trials of different product categories using memory mirrors (Parekh et al., 2020), which reduced the uncertainty related to purchasing, hygiene and enabled the retailers to bring the in-store experience of touch and feel with virtual tries at customers places (Ameen et al., 2021). Recent studies also revealed that AR helps retailers to influence different buying process stages from information search acquisition to product trials (Javornik, 2016). With the help of AR-based applications retailers can successfully add value for the customer through better experience, engagement (Caboni & Hagberg, 2019) and enhance positive product attitude (Fan et al., 2020).

### Effect of Covid -19 on Retail Sector

COVID-19 pandemic is global and populations around the world did not face the restrictions imposed by the government as prevention measures in past. These restrictions have severely affected the everyday lives of consumers, businesses, and other stakeholders (Pantano et al., 2020). Hwang et al. (2020) pointed out that many physical retail outlets are being closed permanently due to stay-at-home orders and mandatory non-essential businesses closure. The COVID-19 protocols, consumer's greater health

concerns, social distancing, and other unexpected regulations had disturbed the sales of traditional stores and increased the demand for alternative distribution channels (Eger et al., 2021).

While retailers from apparel to electronics, fashion to luxury were fighting for their survival during a pandemic, grocery retailers had seen a surge in purchase due to uncertainty and panic buying. Customers were stockpiling essential and non-essentials which caused a shortage of products at supermarkets' shelves. Hence grocery retailers have taken certain measures like limit the number of products, reduced the operating hours, and ask customers to shop normally during their shopping trips to reduce the effect of panic shopping (Martin et al., 2020). Grocery retailers also leveraged technology for contactless payments or cashless purchases to reduce the chances of the spread of the virus in the physical store environment (Seymour et al., 2020).

Soto-Acosta (2020) opined that many traditional food retailers faced a fall in their sales as dine-in traffic was negligible as the population being asked to go outside only in unavoidable circumstances. Secondly, consumers were interested in the small supply chain from the farm to them due to the probability of virus contamination and employees involved in food preparation (Goddard, 2021). Several food retailers restructured their businesses during a pandemic to survive either by adopting technology-enabled platforms or joined digital food delivery services to connect with customers.

New retail formats like Fashion rental platforms which have been launched to provide sustainable and budget-friendly fashion to customers also faced the consequences of the pandemic. Rental platforms faced declining demand as their target customers were at home due to lockdown implications and other social events like weddings and celebrations were either postponed or happened in a virtual manner (Brydges et. al, 2021). Due to a major shift in consumer behavior and virtual celebrations are being new normal, the survival of these new retail formats is in question during the pandemic and post-pandemic scenario.

**RESEARCH METHODOLOGY**

Due to the unavailability of research based on leveraging technology during the pandemic and exploratory nature of research, authors adopted a qualitative case study-based design. Case study-based research is a popular method that allows researchers to develop and present an in-depth view of a particular situation (Rule et al., 2011) In the qualitative research method non-numerical data has been collected from respondents which facilitates a better understanding of the problem.

**Research Context & Data Collection**

The retail industry contributes about 10% of the GDP of India and employs 46 million people of the total workforce across all Industries (RAI, 2020) hence it is one of the most affected industries due to COVID-19. However, the retail industry is facing enormous challenges due to COVID-19, Indian retailers selling non-essential items have suffered 75% of revenue losses (FICCI, 2020) which leads to questions about survival. The present study investigated not only challenges faced by nonessential retailers but also considered food-based retailers. Research also tried to investigate that how managers formulated strategies with the help of technology to overcome challenges.

Data were collected through a semi-structured interview guide (Moen et al., 2015), however, the discussion was open-ended and flexible. We gathered data from five respondents from five retailers of different product categories (Yin, 2013), compiling information that is appropriate to investigate the research problem. People involved in decision-making and managerial roles were selected as respondents, as they have knowledge about retailers' challenges during the pandemic and they can inform about technologies adopted and leveraged by retailers during the pandemic. Moreover, we also ensured their experience in their respective retail formats. The anonymity and confidentiality of responses are strictly maintained by researchers and the same are communicated to respondents.

Table 1: Profile of respondents

Retailers	Respondent	Products offered by the retailers	Designation
Case A	R1	Luxury accessories	Director & Co-founder
Case B	R2	Multi Brand (Apparels, accessories, home furnishing)	Chief Information officer
Case C	R3	Quick Service Food Retailer	Operations Head
Case D	R4	Food based grocer	Founder & Owner
Case E	R5	Ethnic wear	Director, Business Development

Source: Author's Compilation

### FINDINGS AND DISCUSSION

This section presents the findings of the study. The findings are presented in two sections the challenges faced by retailers during the pandemic and acceptance of technological innovations.

#### Challenges Faced by Retailers

We set out to investigate the challenges faced by retailers during the pandemic in India and our discussions with the respondents from representative retailers indicate that the pandemic has given various challenges to retailers. For example, R5 mentioned that *“we were not prepared to handle this. Initially, we shut down our stores but when the lockdown extended we were stressed about workforce salaries, rents, and other costs.”* Similarly, R1 revealed, *“We were not able to understand how and when the customer will back to stores.”* Based on our data set, the findings related to challenges faced by retailers during a pandemic are as follows:

The major challenge faced in the categories where touch and feel are an important aspect of consumer purchase. As stated by R5, *“In ethnic wear product customers wants to experience the product before purchase. Not only one dress but rather some other complementary products sales are dependent upon customers experience.”* As R2 revealed our challenge was in product categories like perfume and deodorants which we were not able to sell without customers being smelled it.

There were fluctuations in demand and supply, resulting in troublesome operations of retailers. Retailers faced no demand for products for the initial few days of lockdown but after that, with few exceptions, the demand for few products emerged. For example, R3 noted that *“Initially, we didn’t see any demand as stores were closed, but after a few relaxations, some of the customers started ordering. These orders were not enough to manage our operations.”*

Contrary to challenges faced by other non-essential item retailers, food-based grocers had seen panic shopping by consumers due to which most of the products were out of stock. R4 mentioned that *“It was difficult to say no to our loyal customers. As our loyal customers were not able to get the products, we had a fear of losing them. We were not able to receive supplies on time as transportation also got affected due to lockdown.”*

Table 2: Challenges faced by Retailers during COVID-19

Challenges	CASE A		CASE B	CASE C	CASE D	CASE E
Mandatory closure of Stores	*		*	*		*
Contactless Sale (Touch & Feel/Experience issue)	*		*	*		*
Loss in Revenue	*		*	*		*
Supply Issues					*	
Uncertainty of Business	*		*	*	*	*

Source: Author’s Compilation

#### Leveraging Technological Innovations

Along with challenges faced by retailers, our interviews brought to light adoption and technological leveraging by retailers. As the pandemic extended and uncertain, retailers decided to leverage the technology for survival. As Respondent R1 remarked, *“Before the pandemic, we were opening 20 -30 physical stores every six months, but huge losses occurred due to shutdown. We were able to survive only through our website. Secondly, the survival happened due to online presence on different e-platforms.”*

#### Enhancing Widespread Reach

Interestingly the technological adoption has revealed some unexplored markets for retailers. As R 1 mentioned, *“Without having a physical presence in different parts of the country, we were able to reach many customers virtually through technology which we never considered as our target group. The major focus now is to use and adopt technological innovations in all our operations. Technology is helping us to retain our loyal customers and achieve higher targets”.*

**Benefits of Digitalization**

Covid-19 also accelerated the adoption of technology for retailers as it helped them survive. Our respondent R2 revealed, “Covid taught us the power of technology and we moved from traditional mode of retail to digital mode. We all fell but let us accelerate the scenario to move two steps ahead with technology”.

**Website Marketing**

Many retailers have their presence in various channels, but their main source of business and revenue generation was physical stores. During the pandemic, they leveraged their digital presence for survival. A quote from respondent R5, “We had our online presence through a website, but during the pandemic when our customers were not able to reach us, we updated our website with new catalogues and reached them. We also used our website as a communication mode for our customers.”

**App-Based Marketing**

Pure physical stores also leveraged technology to reach consumers and get sales. Food grocers started taking orders from WhatsApp, getting the product home delivered with the help of delivery channels, and receiving payments through e-wallets. Retailers overhauled their all operations with the help of technology. At difficult times technology was the boon for survival.

Furthermore, interviewees were asked to name a few technologies adopted by them. Some interesting but simple technologies like video calls, digital assistants, mailers, e-catalogues, and social media platforms were revealed by respondents R5 and R3.

**Simulating In-store Experience**

“We started giving in-store experience to customers with the help of video calls. Once they finalize the products the detailed discussion happened on Google teams for their final look”. (Respondent 5)

**Consumer Testimonials**

“I asked delivery boys to take pictures of the customer with their permission from a distance to ensure contactless delivery. As well as with photo we can ensure that product is delivered to the right customer.” (Respondent3)

Table 3: Adoption of Technologies for Survival by Retailers during COVID-19

Technologies	CASE A	CASE B	CASE C	CASE D	CASE E
e- platforms	*	*			
Video calls for product feel					*
Contactless Delivery	*	*	*	*	*
e-Wallets	*	*	*	*	*

Source: Author’s Compilation

Technologies adopted by retailers were at different facets of retail as per the challenge faced by them. Figure 1 describes the challenges faced by retailers during the COVID-19 pandemic and the technologies adopted by them to overcome those challenges and sustain their retail businesses.

Technology adoptions were an amalgamation of both existing micro-level technologies as well as macro-level like app development. Initially, most of the retailers were dependent upon micro-level technologies that were already adopted by customers. Hence the probability of obstacles during learning from the customer end can be reduced.

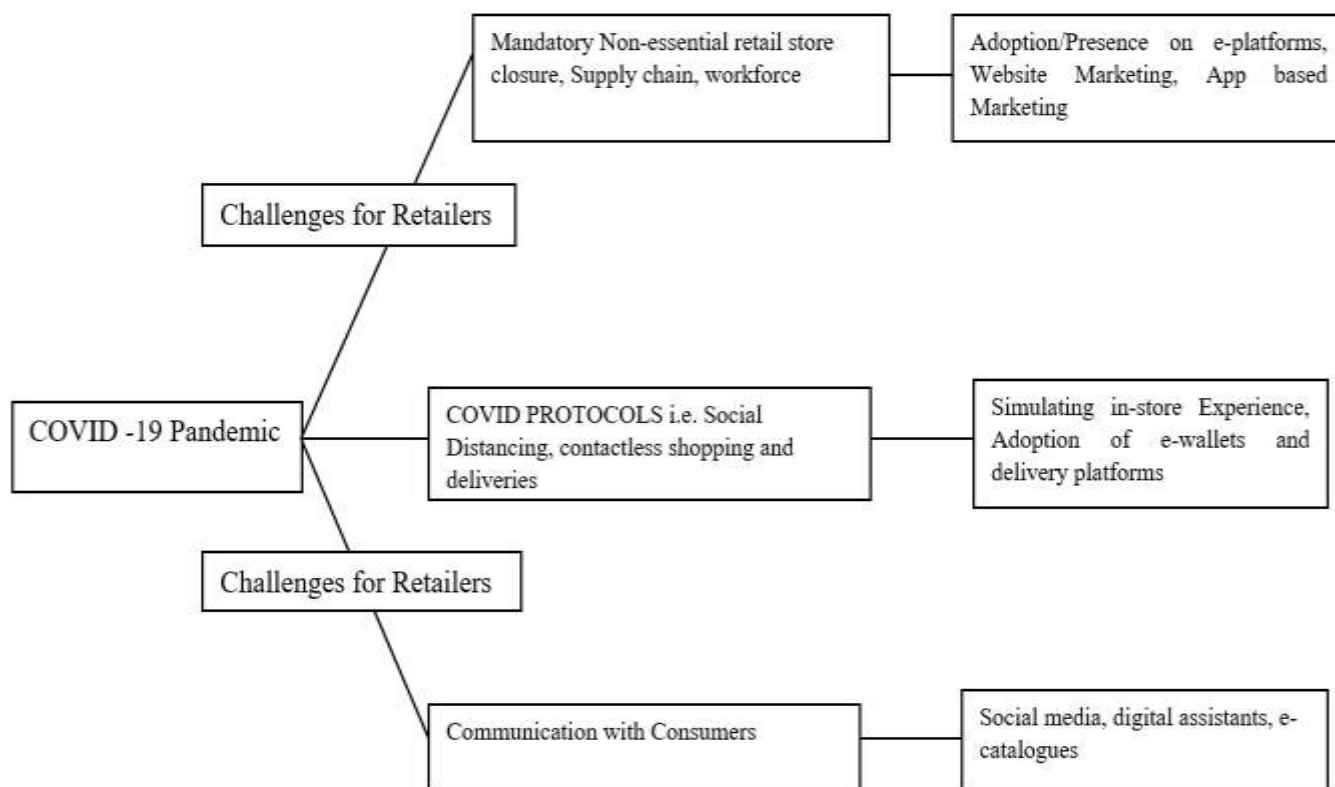

Source: Author’s compilation

Figure 1: Challenges faced by Retailers during Pandemic and Adoption of Technology for Survival

### CONCLUSION

Retailers and brands faced many challenges, such as those related to health and safety, the supply chain, the workforce, cash flow, consumer demand, sales, and marketing (Donthu, 2020). Stewart (2021) pointed out that many non-grocery retailers lost revenue to pay employees, leases, and outstanding invoices, which drastically impacted their survival, as the uncertainty of the post-pandemic retail world is being perceived. After the initial setback, most of the retailers were able to find ways to survive. The major facilitator was technology with the help of that they were able to reach their customers in a challenging environment. Due to the adoption of innovative technologies, the difference between physical and online stores has been negligible (Piotrowicz & Cuthbertson, 2014). Many contactless technologies emerged as the most promising way to support retail processes (Lai & Chuah, 2010) during difficult times. In the scenario of social distancing and other COVID protocols with the help of technology, retailers can manage not only their online survival but also queue and crowd management at physical stores.

### LIMITATIONS & SUGGESTIONS FOR FUTURE RESEARCH

While this qualitative study can be seen to have contributed to the existing literature, it has some limitations. The qualitative nature of the study and the size of the sample minimizes the generalizability of the findings for retailers. Future studies could use quantitative research techniques and larger samples to measure and support their findings. This study was conducted with Indian retailers during the COVID scenario. Future research could be undertaken in different countries with different technological adoptions. In addition, a more in-depth analysis could be conducted to explore other possible challenges faced by retailers during a pandemic.

### REFERENCES

Abed, S. S. (2021). A literature review exploring the role of technology in business survival during the Covid-19 lockdowns. *International Journal of Organizational Analysis*.

Ameen, N., Hosany, S., & Tarhini, A. (2021). Consumer interaction with cutting-edge technologies: Implications for future research. *Computers in Human Behavior*, 120, 106761.

Archer, S. (2015). Snapchat has taken a lead in one of the most disruptive areas of tech. *Business Insider*.

Burke, R. R. (2002). Technology and the customer interface: What consumers want in the physical and virtual store. *Journal of the Academy of Marketing Science*, 30(4), 411-432.

Brydges, T., Heinze, L., Retamal, M., & Henninger, C. E. (2021). Platforms and the pandemic: A case study of fashion rental platforms during COVID-19. *The Geographical Journal*, 187(1), 57-63.

Caboni, F., & Hagberg, J. (2019). Augmented reality in retailing: A review of features, applications and value. *International Journal of Retail & Distribution Management*.



- Dholakia, U. M., Kahn, B. E., Reeves, R., Rindfleisch, A., Stewart, D., & Taylor, E. (2010). Consumer behavior in a multichannel, multimedia retailing environment. *Journal of Interactive Marketing, 24*(2), 86-95.
- Donthu, N., & Gustafsson, A. (2020). Effects of COVID-19 on business and research. *Journal of Business Research, 117*, 284.
- Eger, L., Komárková, L., Egerová, D., & Mičík, M. (2021). The effect of COVID-19 on consumer shopping behaviour: Generational cohort perspective. *Journal of Retailing and Consumer Services, 61*, 102542.
- Fan, X., Chai, Z., Deng, N., & Dong, X. (2020). Adoption of augmented reality in online retailing and consumers' product attitude: A cognitive perspective. *Journal of Retailing and Consumer Services, 53*, 101986.
- Faust, F., Roepke, G., Catecati, T., Araujo, F., Ferreira, M. G. G., & Albertazzi, D. (2012). Use of augmented reality in the usability evaluation of products. *Work, 41*(Supplement 1), 1164-1167.
- Goddard, E. (2021). The impact of COVID-19 on food retail and food service in Canada: A second assessment. *Canadian Journal of Agricultural Economics/Revue canadienne d'agroeconomie, 69*(2), 167-175.
- Grewal, D., Gauri, D. K., Roggeveen, A. L., & Sethuraman, R. (2021). Strategizing Retailing in the New Technology Era. *Journal of Retailing, 97*(1), 6-12.
- Grewal, D., Noble, S. M., Roggeveen, A. L., & Nordfalt, J. (2020). The future of in-store technology. *Journal of the Academy of Marketing Science, 48*(1), 96-113.
- Javornik, A. (2016). Augmented reality: Research agenda for studying the impact of its media characteristics on consumer behaviour. *Journal of Retailing and Consumer Services, 30*, 252-261.
- Hollebeek, L. D., Clark, M. K., Andreassen, T. W., Sigurdsson, V., & Smith, D. (2020). Virtual reality through the customer journey: Framework and propositions. *Journal of Retailing and Consumer Services, 55*, 102056.
- Hopping, D. (2000). Technology in retail. *Technology in Society, 22*(1), 63-74.
- Hoyer, W. D., Kroschke, M., Schmitt, B., Kraume, K., & Shankar, V. (2020). Transforming the customer experience through new technologies. *Journal of Interactive Marketing, 51*, 57-71.
- Hwang, E. H., Nageswaran, L., & Cho, S. H. (2020). Impact of COVID-19 on Omnichannel Retail: Drivers of Online Sales during Pandemic. Available at SSRN 3657827.
- Lai, P. M., & Chuah, K. B. (2010, October). Developing an analytical framework for mobile payments adoption in retailing: a supply-side perspective. In *2010 International Conference on Management of e-Commerce and e-Government* (pp. 356-361). IEEE.
- Martin-Neuning, R., & Ruby, M. B. (2020). What does food retail research tell us about the implications of coronavirus (COVID-19) for grocery purchasing habits?. *Frontiers in Psychology, 11*.
- Moen, K., & Middelthon, A. L. (2015). Qualitative research methods. In *Research in medical and biological sciences* (pp. 321-378). Academic Press.
- McLean, G., & Wilson, A. (2019). Shopping in the digital world: Examining customer engagement through augmented reality mobile applications. *Computers in Human Behavior, 101*, 210-224.
- Pantano, E. (2014). Innovation drivers in retail industry. *International Journal of Information Management, 34*(3), 344-350.
- Pantano, E., & Priporas, C. V. (2016). The effect of mobile retailing on consumers' purchasing experiences: A dynamic perspective. *Computers in human behavior, 61*, 548-555.
- Pantano, E., Pizzi, G., Scarpi, D., & Dennis, C. (2020). Competing during a pandemic? Retailers' ups and downs during the COVID-19 outbreak. *Journal of Business Research, 116*, 209-213.
- Parekh, P., Patel, S., Patel, N., & Shah, M. (2020). Systematic review and meta-analysis of augmented reality in medicine, retail, and games. *Visual computing for industry, biomedicine, and art, 3*(1), 1-20.
- Peck, J., & Childers, T. L. (2003). To have and to hold: The influence of haptic information on product judgments. *Journal of Marketing, 67*(2), 35-48.
- Piotrowicz, W., & Cuthbertson, R. (2014). Introduction to the special issue information technology in retail: Toward omnichannel retailing. *International Journal of Electronic Commerce, 18*(4), 5-16.
- Pizzi, G., Scarpi, D., Pichierri, M., & Vannucci, V. (2019). Virtual reality, real reactions?: Comparing consumers' perceptions and shopping orientation across physical and virtual-reality retail stores. *Computers in Human Behavior, 96*, 1-12.
- Rule, P., & John, V. (2011). Your guide to case study research. Pretoria: *van Schaik*.
- Scholz, J., & Smith, A. N. (2016). Augmented reality: Designing immersive experiences that maximize consumer engagement. *Business Horizons, 59*(2), 149-161.
- Seymour, N., Yavelak, M., Christian, C., Chapman, B., & Danyluk, M. (2020). COVID-19 FAQ for grocery stores: General questions and employee health. *EDIS, 2020*(2).
- Souiden, N., Ladhari, R., & Chiadmi, N. E. (2019). New trends in retailing and services.
- Soto-Acosta, P. (2020). COVID-19 pandemic: Shifting digital transformation to a high-speed gear. *Information Systems Management, 37*(4), 260-266.
- Stewart, B. L. (2021). Pandemic Panic and Retail Reconfiguration: Consumer and Supply Chain Responses to COVID-19. *Journal of Family & Consumer Sciences, 113*(1), 7-16.
- Tyrväinen, O., & Karjaluoto, H. (2019). A Systematic Literature Review and Analysis of Mobile Retailing Adoption. *Journal of Internet Commerce, 18*(2), 221-247.
- Varadarajan, R., Srinivasan, R., Vadakkepatt, G. G., Yadav, M. S., Pavlou, P. A., Krishnamurthy, S., & Krause, T. (2010). Interactive technologies and retailing strategy: A review, conceptual framework and future research directions. *Journal of Interactive Marketing, 24*(2), 96-110.
- Yin, R. K. (2013). Validity and generalization in future case study evaluations. *Evaluation, 19*(3), 321-332.
- <https://www.investindia.gov.in/sector/retail-e-commerce> (retrieved on 2/06/21)

<https://ficci.in/ficci-in-news-page.asp?nid=20999> retrieved on (27/07/21)

<https://rai.net.in/images/insights/RAI-Anarock%20Retail%20Report.pdf> retrieved on (27/07/21)

Liu, Z., Deng, W., Chen, H., & Ma, J. (2023). Meet the technological needs of industrial clusters with privacy concerns: A patent recommendation method based on federated learning. In Li, E.Y. *et al.* (Eds.) *Proceedings of The International Conference on Electronic Business, Volume 23* (pp. 436-444). ICEB'23, Chiayi, Taiwan, October 19-23, 2023

## Meet the Technological Needs of Industrial Clusters with Privacy Concerns: A Patent Recommendation Method Based on Federated Learning

Zhaobin Liu <sup>1</sup>  
Weiwei Deng <sup>2,\*</sup>  
Han Chen <sup>3</sup>  
Jian Ma <sup>4</sup>

\*Corresponding author

<sup>1</sup> PhD Candidate, City University of Hong Kong, Hong Kong, China, zhaobiliu2-c@my.cityu.edu.hk

<sup>2</sup> Assistant Professor, South China Normal University, Guangdong, China, weiweideng@m.scnu.edu.cn

<sup>3</sup> Assistant Professor, South China Normal University, Guangdong, China, 1107162944@qq.com

<sup>4</sup> Professor, City University of Hong Kong, Hong Kong, China, isjian@cityu.edu.hk

### ABSTRACT

Although many patent recommendation methods have been proposed to suggest suitable patents, they aim to meet the technological needs of individual companies. Identifying the common technological needs of companies in an industrial cluster is critical. However, companies usually have privacy concerns and hesitate to reveal their technological information. Therefore, we propose a patent recommendation method based on federated learning, which learns a shared recommendation model across companies without direct access to their data and aggregates the preferences of company members in a cluster to identify common technological needs.

*Keywords:* Patent recommendation, industrial cluster, federated learning, and privacy preservation.

### INTRODUCTION

An industrial cluster is a socioeconomic entity characterized by a set of companies located in close proximity in a specific geographic region. The emergence of industrial clusters has brought new drivers of economic growth to nations and significantly changed the traditional rules of industrial and national competitions (MacKinnon et al. 2002). Despite the advantages of uniting small and medium enterprises to achieve a significant economic impact, industrial clusters face the difficulty of inventing innovative technologies and developing patents to protect their business. Previous studies have found that patents can save the cost and time of technological innovation for industries (Cardamone et al. 2015). Consequently, some governments have established specialized institutions to select suitable patents that meet the common technological needs of companies in an industrial cluster. However, given a large number of patents and the vagueness of the common technological needs, manually selecting suitable patents for industrial clusters is ineffective. Therefore, how to automatically identify patents that meet the technological needs of industrial clusters is an important question worth studying.

Recent studies have noticed the necessity of suggesting suitable patents for companies and proposed various patent recommendation methods, such as the collaborative filtering (CF) method (Oh et al. 2013), the content-based (CB) method (Trappey et al. 2021), and the hybrid method (He et al. 2019). Given the advantages of deep learning (DL) in capturing relations between potential patent users and candidate patents, various DL techniques have been introduced to improve patent recommendation performance (Choi et al. 2022). Although many patent recommendation methods exist, they aim to recommend patents personalized to individual companies rather than industrial clusters. Identifying the common technological needs of companies in an industrial cluster is critical to recommend suitable patents to the industrial cluster. However, companies usually have privacy concerns and hesitate to reveal their technological information, such as their latest technological ideas and pending patents (Robertson et al. 2015). Consequently, how to obtain the common technological needs with privacy preservation is a crucial problem for effective patent recommendation in the current context. Unfortunately, no existing research has studied the problem.

To address the abovementioned research gap, we propose a novel patent recommendation method based on federated learning (FL), which learns a shared recommendation model across companies without direct access to their data and thus enables patent recommendation with privacy preservation. Specifically, the proposed method designs a recommendation model based on the Deep Structured Semantic Model (DSSM) (Huang et al., 2013) and a hierarchical federated learning (HFL) mechanism to train the recommendation model and generate recommendations. We further design an intermediate aggregation method based on differential privacy (DP) and a global aggregation method based on Secure Aggregation Protocol (SAP) to avoid data leakage when training the recommendation model across companies. To evaluate the proposed method, we conduct an offline experiment.

Compared to multiple baseline methods, the proposed method (HFL-DSSM) achieves good recommendation performance in terms of recall and Normalized Discounted Cumulative Gain (NDCG) while preserving privacy. To the best of our knowledge, this is the first study that meets the technological needs of industrial clusters with a novel patent recommendation method based on FL. This research provides a practical solution to government institutions and patent supplier platforms that aim to suggest suitable patents to industrial clusters.

The rest of this paper is organized as follows. Section 2 reviews relevant studies on patent recommendation and FL. Section 3 introduces the proposed patent recommendation method in detail. Section 4 specifies the experiment procedure and experimental results. Section 5 concludes this research.

## RELATED WORK

### Patent Recommendation

As the number of patents is growing large, patent users face information overload when finding suitable ones. To address the information overload challenge, researchers have proposed many patent recommendation methods that are divided into three main types: CF, CB, and hybrid methods (Chen and Deng 2023).

CF methods recommend patents to a target user by calculating the similarity between the target user and other users, selecting the most similar neighbors for the target user, and identifying patents liked by the similar neighbors (Ji et al. 2011; Trappey et al. 2021). However, CF methods face two challenges in recommending patents in the trading context: First, there is a patent cold start problem because most patents remain untransferred and are out of the recommendation scope of CF methods (Deng and Ma 2022). Second, many transferred patents are unsuitable for recommendation to other companies or industrial clusters because of exclusivity clauses in patent trading contracts (Wang et al. 2019).

CB methods recommend patents to a target user by constructing profiles for the target user and each candidate patent and generating recommendations by measuring the similarity between the two profiles (Chen and Chiu 2011; Krestel and Smyth 2013). Many CB methods for patent recommendation require user input and thus are infeasible when users provide no explicit needs. In such cases, patents owned or interacted with by users can be used to indicate their technological preferences. For instance, Deng and Ma (2022) constructed a patent knowledge graph by extracting keywords and their co-occurrence relationships from patents, profiled companies as sub-knowledge graphs based on their patents, and generated recommendations by comparing the sub-knowledge graphs of target companies and candidate patents.

Hybrid patent recommendation methods have also been proposed to integrate the advantages of CF and CB methods for better recommendation performance. For example, Oh et al. (2013) proposed a two-stage patent reference recommendation framework that uses a CB method to obtain candidate patent sets and a CF method to generate patent recommendation lists. Wang et al. (2019) proposed a hybrid patent recommendation method based on a heterogeneous information network and leveraged meta-path analysis to combine CF and CB for generating recommendations. Because of the patent cold start problem, hybrid patent recommendation methods have similar performance to CB methods in the patent trading context.

In recent years, various DL techniques have been applied in patent recommender systems. For example, the multi-layer perceptron has been used to measure the relevance between profiles of companies and patents (Lee and Sohn 2021). Long short-term memory networks have been employed to model sequential patents to capture dynamic company preferences for patents (Du, Yan, et al. 2021). Due to the strong learning capability, DL-based patent recommendation methods usually outperform traditional CB, CF, and hybrid patent recommendation methods. However, existing patent recommendation methods mainly focus on meeting the technological needs of individual companies. Little is known about how to meet the common technological needs of industrial clusters. Moreover, the privacy concern of companies in the current context is seldom explored.

### Federated Learning-Enabled Recommendations

FL is a machine learning (ML) setting where multiple clients learn a model collaboratively on a central server while keeping client data decentralized (Banabilah et al. 2022). Compared to traditional ML settings, FL resolves the privacy concern of the clients by allowing client data to remain on their local devices. To collaboratively train an ML model in FL, a global model is initialized on a central server and broadcasted to a pool of clients, each of whom trains a local model with their personal data and local devices. Then, the updated parameters of each trained local model are sent back to the central server to update the global model parameters. The updated global model can be broadcasted to another pool of clients for further training. As a new ML setting, FL was first introduced by Google (Konečný et al. 2017) and has attracted considerable attention from various research domains (Liu et al. 2021; Nguyen et al. 2021).

Given the capability of privacy preservation in training ML models, FL has also been used to facilitate personalized recommendations with privacy concerns. For example, Qi et al. (2020) proposed a privacy-preserving method for news recommendation model training based on FL. Yin et al. (2022) proposed a federated recommendation approach based on a graph convolution network for recommending industrial services to companies. Qin et al. (2022) proposed a privacy-preserving FL framework for recommending multimedia courses to online students. These studies have demonstrated the capability of FL in enabling privacy-preserving recommendations.

Although FL has been used in various recommendation contexts, no existing studies have explored its application in patent recommendation for industrial clusters. Different from previous recommendation studies, patent recommendation in the current context requires extracting common technological needs from multiple companies in an industrial cluster. However, limited knowledge is known about how to obtain common technological needs of industrial clusters when applying FL in the patent recommendation.

### THE PROPOSED METHOD

Our goal is to recommend suitable patents to industrial clusters without direct access to the data of each company. Thus, we adopt the FL paradigm and propose a patent recommendation method based on FL. The FL paradigm needs to train a local recommendation model for each company and aggregate their parameters or gradients to obtain a global recommendation model. During the aggregation process, encryption technologies are needed to prevent information leakage. The following introduces our recommendation model and the hierarchical federated learning mechanism designed to train the recommendation model and generate recommendations.

#### The Recommendation Model

The interaction between companies and patents is sparse because patents are highly exclusive. Therefore, we design a CB recommendation model based on DSSM, a semantic model used to learn semantic representations of textual contents and calculate the similarity between the representations. Specifically, the recommendation model contains a patent model and a company model that learn the semantic representations of a patent and a company, respectively. The patent and company models use the following N-layer neural network with different sets of parameters:

$$\begin{aligned} l_1 &= \mathbf{W}_1 x \\ l_i &= f(\mathbf{W}_i l_{i-1} + b_i), i = 2, \dots, N-1 \\ y &= f(\mathbf{W}_N l_{N-1} + b_N) \end{aligned} \quad (1)$$

where  $x$  is the original feature vector of a patent or a company,  $\mathbf{W}_i$  is the weight matrix of the  $i$ -th layer,  $b_i$  is the bias term of the  $k$ -th layer,  $y$  is the semantic representation of a patent or a company, and  $f(\cdot)$  is the tanh function, i.e.,  $f(x) = (1 - e^{-2x}) / (1 + e^{-2x})$ .

The recommendation model then calculates the similarity between a company  $c$  and a candidate patent  $p$  based on their semantic representations:

$$S(c, p) = \frac{y_c^T y_p}{\|y_c\| * \|y_p\|} \quad (2)$$

We optimize the parameters of the recommendation model by minimizing the loss function  $\mathcal{L}(\Lambda)$ :

$$\mathbb{P}(p|c) = \frac{\exp(\gamma S(c, p))}{\sum_{p' \in P} \exp(\gamma S(c, p'))} \quad (3)$$

$$\mathcal{L}(\Lambda) = -\log \prod_{(c, p^+)} \mathbb{P}(p^+|c) \quad (4)$$

where  $\gamma$  is a smoothing factor for controlling the softness of the probability distribution in the softmax function.  $P$  is the set of candidate patents to be recommended and ideally contains all possible patents. In practice, given a company  $c$ , we approximate  $P$  by constructing a patent set  $\{p^+, p_k^-\}; k = 1, 2, \dots, K\}$  for model training. Here,  $p^+$  denotes a patent common to the industrial cluster to which company  $c$  belongs and  $p_k^-$  denotes a randomly selected patent non-common to the industrial cluster.  $\mathbb{P}(p|c)$  indicates the posterior probability that patent  $p$  is a common patent given  $c$ .  $\Lambda$  denotes the parameter set  $\{\mathbf{W}_i, b_i\}$  and  $(c, p^+)$  is any (company, common patent) pair in a training set. Therefore,  $\mathcal{L}(\Lambda)$  indicates that the parameters are estimated to maximize the likelihood of the common patents given the companies across the training set.

#### Hierarchical Federated Learning Mechanism

Figure 1 presents the hierarchical FL mechanism, which contains multiple first-tier FL clients, second-tier FL clients, and an FL server. Here, a first-tier FL client refers to a company, a second-tier FL client indicates an industrial cluster, and the FL server is the platform that provides recommendation services to industrial clusters. The mechanism contains training and prediction algorithms as introduced below.

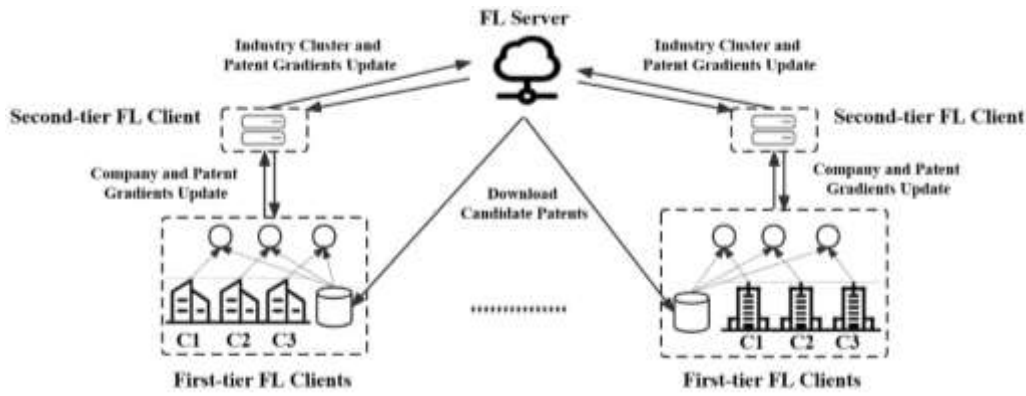

Figure 1: The Framework of the Hierarchical Federated Learning Mechanism

### Training Algorithm

We define an industrial cluster with  $N$  companies as  $\mathbf{IC} = \{c_1, c_2, \dots, c_N\}$  and a set of candidate patents  $P$  shared across the companies. In the proposed hierarchical FL mechanism, the FL server first initializes a global recommendation model (with a company model and a patent model for representation learning) and distributes it to each first-tier FL client. Then, each first-tier FL client trains a local recommendation model based on its own data and uploads the gradients of company and patent models to the second-tier FL clients. After that, each second-tier FL client aggregates the uploaded gradients of the company and patent models, respectively, and uploads the aggregated gradients to the FL server. Last, the FL server further aggregates the gradients from second-tier FL clients, updates the global recommendation model, and distributes the updated global model to the second-tier and first-tier FL clients.

We use a training algorithm to describe this process, which continues until the global recommendation model converges. The training algorithm is formally defined in Algorithm 1. The aggregation strategy used in the training algorithm is defined based on the FedAvg manner (Konečný et al. 2017):

$$\mathbf{W} = \sum_{c=1}^C \frac{m_c}{m} \mathbf{W}_c \quad (5)$$

where  $\mathbf{W}$  indicates the aggregated gradients,  $\mathbf{W}_c$  represents the gradients of the  $c$ -th FL client,  $C$  is the number of FL clients,  $m_c$  is the number of training samples on the  $c$ -th FL client, and  $m$  is the total number of training samples.

The hierarchical FL mechanism has two main threats to privacy. The first one is brought by the traditional FL: the first-tier FL clients, second-tier clients, and FL server are active adversaries who may break the FL protocol, such as sending incorrect messages to honest clients. The second one is brought by aggregating the gradients of company and patent models in an industry cluster. For example, one company may infer the updates of other companies in the same industry cluster by making a null update to shared local patent models and making a null update to company models. A malicious company is likely to know the information of the other companies by subtracting its own value from the aggregated value (Zhu et al. 2019). Therefore, we design an `Intermediate_safety_aggregate()` method based on DP for the aggregation process on second-tier FL clients and a `global_safety_aggregate()` method based on SAP for the aggregation process on the FL server. The former method disables companies' ability to infer other companies' updates and the latter method ensures that the FL server has no information about the update of each second-tier FL client.

### Algorithm 1: The Training Algorithm

First-tier FL Client (Company level):

Input:

The number of companies in the industry cluster  $\mathbf{IC}$ :  $N$ .

The dataset of the industry cluster's  $i$ -th company:  $c_i$ .

Industry cluster's patent (common and non-common patent) behavior data:  $P$ .

The number of FL training rounds  $T$ .

Learning rate  $\eta$ .

Initial company model weights:  $\mathbf{W}_{c_0}^0$ .

Initial patent model weights:  $\mathbf{W}_P^0$ .

Output:

The company sub-model weights:  $\mathbf{W}_{c_i}^T, i \in \{1, \dots, N\}$ . The patent sub-model weights:  $\mathbf{W}_P^T$ .

for  $t = 1: T$  do

  for each company in the industry cluster  $i = 1: N$  do

$$(g_P^t)_i = \frac{\partial L(\mathbf{W}_{c_i}^t, \mathbf{W}_P^t, c_i, P)}{\partial L \mathbf{W}_P^t},$$

$$g_{c_i}^t = \frac{\partial L(\mathbf{W}_{c_i}^t, \mathbf{W}_P^t, c_i, P)}{\partial L \mathbf{W}_{c_i}^t},$$

---

```

end for
 $g_P^t = \text{Intermediate\_safety\_aggregate}((g_P^t)_i, i \in \{1, \dots, N\})$ .
 $G_P^t = \text{global\_safety\_aggregate}(g_P^t)$ .
 $g_{IC}^t = \text{Intermediate\_safety\_aggregate}(g_{c_i}^t, i \in \{1, \dots, N\})$ .
 $G_{IC}^t = \text{global\_safety\_aggregate}(g_{IC}^t)$ .
 $\mathbf{W}_P^{t+1} = \mathbf{W}_P^t - \eta G_P^t$ .
for each company in the industry cluster  $i = 1: N$  do
     $\mathbf{W}_{c_i}^{t+1} = \mathbf{W}_{c_i}^t - \eta G_{IC}^t$ .
end for
end for

Second-tier FL Client (Industry Cluster Level)
Input:
    The number of Company  $N$ .
    The number of FL training round  $T$ .
First-tier FL client updates  $(g_P^t)_i, i \in \{1, \dots, N\}$  in FL round  $t$ .
First-tier FL client updates  $g_{c_i}^t, i \in \{1, \dots, N\}$  in FL round  $t$ .
Output:
    Securely aggregate FL company's summative information, e.g., gradients.
    For  $t = 1: T$  do
        Second-tier FL client  $\text{Client\_aggregate}((g_P^t)_i, i \in \{1, \dots, N\})$ .
        Second-tier FL client  $\text{Client\_aggregate}(g_{c_i}^t, i \in \{1, \dots, N\})$ .
    end for

FL Server:
Input:
    The number of industry clusters  $R$ .
    The number of FL training rounds  $T$ .
Second-tier FL client updates  $(G_P^t)_j, j \in \{1, \dots, R\}$  in FL round  $t$ .
Second-tier FL client updates  $(G_{IC}^t)_j, j \in \{1, \dots, R\}$  in FL round  $t$ .
Output:
    Securely aggregate FL industry cluster's summative information, e.g., gradients.
    For  $t = 1: T$  do
         $\text{server\_aggregate}((G_P^t)_j, j \in \{1, \dots, R\})$ .
         $\text{server\_aggregate}((G_{IC}^t)_j, j \in \{1, \dots, R\})$ .
    end for

```

---

### Prediction Algorithm

After obtaining the global recommendation model, the hierarchical FL mechanism uses the model to calculate the probabilities that a candidate patent meets the technological needs of each company in an industrial cluster. Then, the mechanism aggregates the probabilities and recommends candidate patents with the highest aggregated probabilities to the industrial cluster. We use a prediction algorithm to describe this recommendation process. The prediction algorithm is formally defined in Algorithm 2.

Algorithm 2: The Prediction Algorithm

---

```

First-tier FL Client:
Input:
    The number of candidate patents:  $H$ .
    The number of companies in the industry cluster:  $N$ .
    The sub-model of the industry cluster's  $i$ -th company:  $\mathbf{W}_{c_i}, i \in \{1, \dots, N\}$ ..
    Patent sub-model:  $\mathbf{W}_P$ .
    The feature of the industry cluster's  $i$ -th company:  $c_i, i \in \{1, \dots, N\}$ .
    The feature of the  $j$ -th candidate patent:  $P_j, j \in \{1, \dots, H\}$ .
Output:
 $\mathbb{P}(P_j | c_i), i \in \{1, \dots, N\}$  and  $j \in \{1, \dots, H\}$ .
    For each patent  $j = 1: H$  do
        Compute  $y_{P_j}$ , where  $y_{P_j} = f(\mathbf{W}_P, P_j)$  according to Equation (1).
    end for

```

---



---

```

end for
for each company in the industry cluster  $i = 1: N$  do
  Compute  $y_{c_i}$ , where  $y_{c_i} = f(\mathbf{W}_{c_i}, c_i)$  according to Equation (1).
  for each patent  $j = 1: H$  do

$$\mathbb{P}(P_j | c_i) = \frac{\exp(\gamma S(y_{c_i}, y_{P_j}))}{\sum_{P' \in P} \exp(\gamma S(y_{c_i}, y_{P'}))}$$

  end for
end for
Intermediate_safety_aggregate( $\mathbb{P}(P_j | c_i), i \in \{1, \dots, N\}$ ) and  $j \in \{1, \dots, H\}$ .

```

Second-tier FL Client:

Input:

First-tier FL client updates ( $\mathbb{P}(P_j | c_i), i \in \{1, \dots, N\}$  and  $j \in \{1, \dots, H\}$ ).

Output:

List of top-K patents for recommendation.

$\mathbb{P}(P_j | \mathbf{IC}) = \text{Second} - \text{tier FL Client\_aggregate}(\mathbb{P}(P_j | c_i), i \in \{1, \dots, N\})$ ,

$j \in \{1, \dots, H\}$ .

Select top-K candidate patents by sorting  $\mathbb{P}(P_j | \mathbf{IC})$ , where  $j \in \{1, \dots, H\}$ .

---

## EXPERIMENT EVALUATION

### Data Collection and Sample Generation

We collected industrial cluster data and patent data in the biotechnology industry from the Qianzhan website (<https://y.qianzhan.com/>) and the Qichacha website (<https://www.qcc.com/>), respectively. The former website contains comprehensive data of industrial clusters in China and the latter website is the largest platform offering various data about Chinese enterprises. After obtaining the original data, we generated samples with two steps. First, we obtain an industrial cluster set by applying inclusion criteria: 1) an industrial cluster should relate to the biotechnology industry, 2) the industrial cluster contains at least three companies, and 3) every company in the industrial cluster has at least 15 patents. Second, we identify the common and non-common patents after 2017 for each industrial cluster according to the following definitions: 1) common patents are the patents in the patent pool of the industrial cluster. The companies in the industrial cluster can share the patents in the patent pool with a license agreement. 2) non-common patents are the patents, which are not in the patent pool and used by each company in the industrial cluster.

Table 1 describes the sample data in detail. In our dataset, a sample is a pair of a company and a patent. We define the patents used by the companies in 2017 or before as their technological needs and the patents used by the companies after 2017 as candidate patents. A sample (a company, a candidate patent) is positive if the candidate patent is common to the industry cluster to which this company belongs and negative otherwise.

Table 1: Data Description

Industry	Number of Industrial Clusters	Number of Positive Samples	Number of Negative Samples	Number of Samples
Biotechnology	313	2376	7833	10209

### Baseline Methods

We compare the proposed patent recommendation method against state-of-the-art patent recommendation methods and FL-based recommendation methods.

- Knowledge-aware attentional bidirectional long short-term memory network (KBiLSTM) (Du, Jiang, et al. 2021): this method is trained on centralized data and used to generate recommendation lists for all companies in an industry cluster. Then, it aggregates all lists to obtain the final recommendation list with an average strategy.
- C-DSSM: this method, trained on centralized data, generates recommendation lists for all companies in an industry cluster and then aggregates all lists to obtain the final recommendation list with an average strategy.
- FL-DSSM: this method is trained on the traditional FL framework, which has only first-tier clients and aggregates the gradients from the first-tier clients on the central server.

### Evaluation Metrics

To evaluate the performance of patent recommendation, we adopt two general metrics, Recall@N and NDCG@N, where N is the number of recommended patents and set to 5, 15, or 25. For these two metrics, a larger value implies better performance. Recall is the ratio of correctly recommended patents to all testing patents. It is mathematically defined below.

$$\text{Recall@N} = \frac{|\hat{P}_{\mathbf{IC}, N} \cap P_{\mathbf{IC}}|}{|P_{\mathbf{IC}}|} \quad (6)$$

where  $\hat{P}_{IC,N}$  denotes the set of top-N recommended patents for industrial cluster IC and  $P_{IC}$  is the set of testing patents for industrial cluster IC.

NDCG considers not only the percentage of correctly recommended patents but also their positions in the recommendation list. Its mathematical definition is given as follows.

$$DCG@N = \sum_{p \in \hat{P}} \frac{\delta N(p)}{\log_2(i_p+1)} \quad (7)$$

$$NDCG@N = \frac{DCG@N}{IDCG@N} \quad (8)$$

where  $p$  is a patent in the recommendation list  $\hat{P}$ ,  $i_p$  is the index of patent  $p$  in the recommendation list, and  $\delta N()$  is a function that equals 1 if patent  $p$  is in the testing patent set and 0 otherwise. IDCG is the DCG of ground-truth patents list in descending order based on predicted scores.

### Environmental Setup

We partition the data into train and test sets with a train-to-test ratio of 80: 20. We randomly combine 1 (company, common patent) pair and 4 (company, non-common patent) pairs to train local recommendation models on each first-tier client. The FL-DSSM and HFL-DSSM are implemented in TensorFlow Federated simulation framework (<https://www.tensorflow.org/federated>).

### Experimental Results

Table 2 reports the recommendation results of different recommendation methods. Overall, the proposed method achieved good recommendation performance while protecting privacy. We have several detailed findings from the results. Firstly, C-DSSM performs better than KBiLSTM in exploring the common technological needs of industrial clusters. This finding justifies the use of DSSM for patent recommendation with the FL framework.

Secondly, although HFL-DSSM has worse results than C-DSSM, the difference in their recommendation performance is small. Moreover, HFL-DSSM allows companies to keep their data, thus enabling privacy preservation. This finding suggests that HFL-DSSM protects privacy of companies by sacrificing only a small amount of recommendation performance.

Thirdly, HFL-DSSM outperforms FL-DSSM in all cases with the only exception of NDCG@15. This finding indicates that the proposed hierarchical FL mechanism can better capture industrial clusters' common technological needs than the traditional FL mechanism. In addition, FL-DSSM is prone to privacy leakage because the lack of encryption procedure when aggregating the recommendation results of company members in each industrial cluster. For example, a company may infer the technical secrets of other companies based on their recommendation results. Therefore, compared to the traditional FL mechanism, the proposed hierarchical FL mechanism has better capabilities in capturing the common technological needs and protecting the privacy of industrial clusters.

Table 2: Comparison between Different Recommendation Methods

Model		KBiLSTM	C-DSSM	FL-DSSM	HFL-DSSM
@5	Recall	2.152	2.243	2.125	2.164
	NDCG	2.549	2.74	2.537	2.632
@15	Recall	3.577	3.792	3.553	3.582
	NDCG	3.231	3.326	3.258	3.203
@25	Recall	4.325	4.409	4.331	4.364
	NDCG	3.242	3.413	3.235	3.297

### Analysis of Parameter Sensitivity

To analyze the sensitivity of the ratio of positive samples to negative samples used to train HFL-DSSM, we set the ratio to 1: K ( $K \in \{4, 5, 6, 7\}$ ) and compare the recommendation results with different ratios. The recommendation results shown in Table 3 indicate that Recall@N and NDCG@N have very small changes as the ratio varies. This means that the ratio has little effect on the training process of HFL-DSSM.

Table 3: Comparison between Different Numbers of Negative Samples

Model		HFL-DSSM (K = 4)	HFL-DSSM (K = 5)	HFL-DSSM (K = 6)	HFL-DSSM (K = 7)
@5	Recall	2.164	2.159	2.161	2.163
	NDCG	2.632	2.633	2.631	2.637
@15	Recall	3.582	3.583	3.579	3.581
	NDCG	3.203	3.202	3.204	3.198

@25	Recall	4.364	4.362	4.361	4.357
	NDCG	3.297	3.294	3.301	3.293

### CONCLUSIONS AND FUTURE WORK

Transferring patents to industrial clusters plays an important role in protecting and promoting the business of the industrial clusters. Although many patent recommendation methods have been proposed to identify suitable patents for companies, they aim to meet the technological needs of individual companies rather than industrial clusters. Besides, companies in an industrial cluster hesitate to reveal their technological data because of privacy concerns. In this research, we propose a patent recommendation method based on federated learning to recommend suitable patents to industrial clusters with privacy preservation. The experimental results demonstrate that our proposed patent recommendation method achieves comparable performance to baseline methods, while effectively ensuring the privacy of companies. The main contribution of this research is the newly designed patent recommendation method, which can be used by government institutions and online patent trading platforms that aim to suggest suitable patents to industrial clusters with privacy concerns. This research also contributes to the patent recommendation domain by addressing a new patent recommendation problem and the FL domain by extending the application scope of FL methods.

There are several directions for future work. First, future research could conduct more experiments to better investigate the effectiveness of the proposed method. Currently, only the data from the biotechnology industry were used and three baseline methods were chosen for comparison. To further validate the effectiveness of the proposed method, future research could evaluate its performance with data from multiple industries and compare it with other state-of-the-art recommendation techniques. Second, future research could refine the aggregation strategy for aggregating the recommendation results of company members in each industrial cluster. One potential approach is assigning individual weights to each company, reflective of their level of influence within the industrial cluster. Such aggregation design may lead to more accurate and beneficial patent recommendations for industrial clusters.

### ACKNOWLEDGMENT

This research was supported by grants from the Guangdong Basic and Applied Basic Research Foundation (No. 2022A1515110677), the Natural Science Foundation of Guangdong Province (No. 2022A1515011363), the Shenzhen Commission of Science and Technology (No. 9240067), and the National Natural Science Foundation of China (No. J2124019).

### REFERENCES

- Banabilah, S., Alokaily, M., Alsayed, E., Malik, N., & Jararweh, Y. (2022). Federated Learning Review: Fundamentals, Enabling Technologies, and Future Applications. *Information Processing & Management*, 59(6), 103061.
- Cardamone, P., Pupo, V., & Ricotta, F. (2015). University Technology Transfer and Manufacturing Innovation: The Case of Italy. *Review of Policy Research*, 32(3), 297–322.
- Chen, H., & Deng, W. (2023). Interpretable Patent Recommendation with Knowledge Graph and Deep Learning. *Scientific Reports*, 13(1), 2586.
- Chen, Y.-L., & Chiu, Y.-T. (2011). An IPC-Based Vector Space Model for Patent Retrieval. *Information Processing & Management*, 47(3), 309–322.
- Choi, J., Lee, J., Yoon, J., Jang, S., Kim, J., & Choi, S. (2022). A Two-Stage Deep Learning-Based System for Patent Citation Recommendation. *Scientometrics*, 127(11), 6615–6636.
- Deng, W., & Ma, J. (2022). A Knowledge Graph Approach for Recommending Patents to Companies. *Electronic Commerce Research*, 22(4), 1435–1466.
- Du, W., Jiang, G., Xu, W., & Ma, J. (2021). Sequential patent trading recommendation using knowledge-aware attentional bidirectional long short-term memory network (KBiLSTM). *Journal of Information Science*. <https://doi.org/10.1177/01655515211023937>
- Du, W., Yan, Q., Zhang, W., & Ma, J. (2021). Leveraging Online Behaviors for Interpretable Knowledge-Aware Patent Recommendation. *Internet Research*, 32(2), 568–587.
- Huang, M., Li, H., Bai, B., Wang, C., Bai, K., & Wang, F. (2020). A federated multi-view deep learning framework for privacy-preserving recommendations. *arXiv preprint arXiv:2008.10808*.
- Huang, P.S., He, X., Gao, J., Deng, L., Acero, A., & Heck, L. (2013). Learning deep structured semantic models for web search using clickthrough data. In *Proceedings of the 22nd ACM international conference on Information & Knowledge Management*, pp. 2333–2338.
- He, X., Dong, Y., Zhen, Z., Wu, Y., Jiang, G., Meng, X., & Ma, S. (2019). Weighted Meta Paths and Networking Embedding for Patent Technology Trade Recommendations among Subjects. *Knowledge-Based Systems*, 184, 104899.
- Ji, X., Gu, X., Dai, F., Chen, J., & Le, C. (2011). Patent Collaborative Filtering Recommendation Approach Based on Patent Similarity. In *2011 Eighth International Conference on Fuzzy Systems and Knowledge Discovery (FSKD) (Vol. 3)*, July, pp. 1699–1703.
- Konečný, J., McMahan, H. B., Yu, F. X., Richtárik, P., Suresh, A. T., & Bacon, D. (2017). Federated Learning: Strategies for Improving Communication Efficiency. *arXiv*.

- Krestel, R., & Smyth, P. (2013). Recommending Patents Based on Latent Topics. In *Proceedings of the 7th ACM Conference on Recommender Systems, RecSys '13*, New York, NY, USA: Association for Computing Machinery, October 12, pp. 395–398.
- Lee, J., & Sohn, S. Y. (2021). Recommendation System for Technology Convergence Opportunities Based on Self-Supervised Representation Learning. *Scientometrics*, 126(1), 1–25.
- Liu, M., Ho, S., Wang, M., Gao, L., Jin, Y., & Zhang, H. (2021). Federated Learning Meets Natural Language Processing: A Survey. *arXiv*.
- MacKinnon, D., Cumbers, A., & Chapman, K. (2002). Learning, Innovation and Regional Development: A Critical Appraisal of Recent Debates. *Progress in Human Geography*, 26(3), 293–311.
- Nguyen, D. C., Ding, M., Pathirana, P. N., Seneviratne, A., Li, J., & Vincent Poor, H. (2021). Federated Learning for Internet of Things: A Comprehensive Survey. *IEEE Communications Surveys & Tutorials*, 23(3), 1622–1658.
- Oh, S., Lei, Z., Lee, W.-C., Mitra, P., & Yen, J. (2013). CV-PCR: A Context-Guided Value-Driven Framework for Patent Citation Recommendation. In *Proceedings of the 22nd ACM International Conference on Information & Knowledge Management, CIKM '13*, New York, NY, USA: Association for Computing Machinery, October 27, pp. 2291–2296.
- Qi, T., Wu, F., Wu, C., Huang, Y., & Xie, X. (2020). Privacy-Preserving News Recommendation Model Learning. In *Findings of the Association for Computational Linguistics: EMNLP 2020*, Online: Association for Computational Linguistics, November, pp. 1423–1432.
- Qin, Y., Li, M., & Zhu, J. (2022). Privacy-Preserving Federated Learning Framework in Multimedia Courses Recommendation. *Wireless Networks*, pp. 1–10.
- Robertson, K. M., Hannah, D. R., & Lautsch, B. A. (2015). The Secret to Protecting Trade Secrets: How to Create Positive Secrecy Climates in Organizations. *Business Horizons*, 58(6), 669–677.
- Trappey, A., Trappey, C. V., & Hsieh, A. (2021). An Intelligent Patent Recommender Adopting Machine Learning Approach for Natural Language Processing: A Case Study for Smart Machinery Technology Mining. *Technological Forecasting and Social Change*, 164, 120511.
- Wang, Q., Du, W., Ma, J., & Liao, X. (2019). Recommendation Mechanism for Patent Trading Empowered by Heterogeneous Information Networks. *International Journal of Electronic Commerce*, 23(2), 147–178.
- Yin, Y., Li, Y., Gao, H., Liang, T., & Pan, Q. (2022). FGC: GCN Based Federated Learning Approach for Trust Industrial Service Recommendation. *IEEE Transactions on Industrial Informatics*, pp. 1–11.
- Zhu, L., Liu, Z., & Han, S. (2019). Deep Leakage from Gradients. In *Advances in Neural Information Processing Systems (Vol. 32)*, Curran Associates, Inc.

## Mitigating Effects of the Early Warning Time on Individual Work Technostress

Xi Chen <sup>1,\*</sup>  
Wei-Hsi Hung <sup>2</sup>

\*Corresponding author

<sup>1</sup> Doctoral Student, Department of Management Information Systems, National Chengchi University, Republic of China (Taiwan), [xiic0403@gmail.com](mailto:xiic0403@gmail.com)

<sup>2</sup> Professor, Department of Management Information Systems, National Chengchi University, Republic of China (Taiwan), [fhung@nccu.edu.tw](mailto:fhung@nccu.edu.tw)

### ABSTRACT

Despite the popularity of remote work in the Covid-19 pandemic, little research attention has been paid to examining how individuals can mitigate technostress in the remote work, especially work from home. To fill this gap, the authors first reviewed the extant literature and found some difficulties of adopting the mitigating approach suggested by those studies. Then, the authors suggest a new model and a workable plan to moderate remote work exhaustion when the proposed approach is used for reducing progressive distancing technostress. To be more specific, the authors posited that early warning time could moderate the relationship between technostress and remote work exhaustion. The authors suggested presetting it in the computer system using a tool called "Windows Task Scheduler" to activate this early warning mechanism. The novel concept should make contributions to the mitigation of technostress.

*Keywords:* Technostress, Work Exhaustion, Early Warning

### INTRODUCTION

Before the outbreak of COVID-19, remote work was an unusual way in the enterprise, moreover, the studies on remote work focused almost completely on those who voluntarily work from home (Kniffin et al., 2021). However, as the COVID-19 was spiraling out of control, the pattern of remote work has become an essential part of pandemic control meanwhile the public acceptance of remote work has increased over time (Mukherjee & Narang, 2023). While remote work is gradually becoming common, technostress is still on the rise and invades the life of individual day-in-day-out (Oksanen et al., 2021). The authors now have enough evidence to support the fact that the psychological challenges and risks (i.e., work exhaustion) that remote employees confront in the event of COVID-19 (Estrada-Muñoz et al., 2021; Gabr et al., 2021). It is hence relevant to understand how different mechanisms reduce perceptions of technostress and, as a workable approach, mitigate the work exhaustion of employees (Ru-zhe & Agmapisarn, 2023).

The studies on mitigation of technostress have mostly studied the coping strategies of technology stressors, e.g., IT control (Salo et al., 2019) and venting (Pirkkalainen et al., 2017). Some studies have considered technostress mitigation must directly reduce the technical creators (Salo et al., 2022; Weinert et al., 2020). However, the ICT interface as the only communication channel for remote employees seems to be unable to be easily removed, which means that technostress has to be handled in a segmented manner. The studies related to remote work exhaustion have long suggested that online health strategies are required to assist the public in dealing with rising levels of technostress and burnout during COVID-19 (Mheidly et al., 2020). Equally, there are limited studies about the design of views for the computer system to cope with technostress mitigation. Based on this view suggested from the literature, the authors attempt an early warning mechanism on the computer system to allow the remote employees can be away from IT devices in a process of conscious perception with a relaxed status.

In summary, this study was conducted in the form of literature reviews, collecting the current studies about technostress mitigation and emphasizing the importance of the topic.

In the following part, the authors first initiate the literature reviews highlighting the barriers shown in the context of technostress mitigation. Second, the proposed conceptual model is expressed. Third, the authors then discuss the conclusions and contributions of this study. Finally, the authors present the limitations and further research.

### LITERATURE REVIEWS

#### Theory of Stress and Coping

Inspired by the theory of stress and coping (Lazarus, 1966). Coping is defined as adjusting cognitive and behavioral efforts in response to certain additional demands that are perceived to be exceeding the individual's resources (Lazarus & Folkman, 1984). The theory of stress and coping emphasizes the dynamic chain process of how individuals experience stressful events to support adaptive behavior. More precisely, the coping process consists of two component parts, cognitive appraisals, and coping strategies. In cognitive appraisals, the persons evaluate the negative effects of the stress to the individuals by primary and secondary approaches, namely that stress identification and stress strategic management. In coping strategies, the persons strive to handle the conflicts in exceeding personal capability, for example, by mitigation or controlling stress. Taken together, the theory of stress and coping implies acknowledging the general principles of stress mitigation. The authors' focus is to construct

the mitigating mechanism on the computer system to minimize the negative effects of technostress-creating conditions (i.e., work exhaustion) as possible. Thus, the authors adopt the theoretical views of the theory of stress and coping.

### The Studies Overviews of Individual Mitigation of Technostress

Technostress was originally viewed as a computer-generated health ailment (Brod, 1984). Afterward, technostress expanded into workplaces and considered that it is non-optional leads to changes in organizational performance and individual roles (Tarafdar et al., 2014). As the clear definition of "technostress" is rather intricate, several studies have specifically explained that "technostress" is associated with technology fatigue and technology addiction (Salanova et al., 2013). Remote work is characterized by contact with members of an organization through the use of ICT and computer systems all day, with the ICT panel being the almost and only channel at work, remote workers often experience disruptions (e.g., frequently and explosive text messages), workload loads, and work-family conflict (i.e., the blurring of virtual and reality) (Stich, 2020). Also, the common characteristics of ICT to result in work exhaustion are technology overload, technology insecurity, technology invasion, technology complexity, technology uncertainty (Ragu-Nathan et al., 2008). Hence, remote work could be regarded as a phenomenon of technology addiction and technology strain. To better understand the mitigation of the technostress, Weinert et al. (2014) classified technostress mitigation into two distinct aspects, organization-level, and individual level (Weinert et al., 2014). With regard to technostress mitigation at the organization level, technology-support strategies, and emotional-support strategies often symbolized the main approaches to relieve technostress inside the firm. First, technology-support strategies usually refer to providing technical assistance to reduce the technology anxiety of employees. For example, organizations provide the latest system operating guidelines (Reinke et al., 2016). Second, emotional-support strategies usually refer to strengthening the connection between system developers and employees and increasing employees' confidence in the technology. For example, organizations encourage users to use, try out, and evaluate new systems and give feedback (Ragu-Nathan et al., 2008). Here, the authors' interest is to help the remote employees to cope with technostress by mitigation. Thus, the authors concentrate on the reviews for the studies of technostress mitigation at the Individual level in the following part.

With regard to technostress mitigation at the individual level, table 1 explains the workable way that the ICT employees relieve technostress. Several studies have indicated that distancing the ICT environment is the best way to mitigate burnout (Galluch et al., 2015; Salo et al., 2022). Specifically, being away from the ICT environment can relieve the technostress creators, meanwhile, offset the negative effects of technostress antecedent variables on ICT-oriented productivity (Salo et al., 2022; Salo et al., 2019). However, distancing the ICT environment merely offer a channel to temporarily separate from work for employees and conduct alternative tasks, nor a wise and long choice, more importantly, the employees carefully understand how and when to use IT devices (Tarafdar et al., 2020). However, the truth is that employees often undervalue IT usage, and many issues make it tough to turn off the IT device (Salo et al., 2022). In comparison, IT control possibly causes a sense of conflict though reducing the effect of overload (Galluch et al., 2015). On the basis of the above observation, to mitigate the technostress of employees should be a progressive process and automatically conduct the set of activities of distancing technostress on the computer system.

Table 1: The General Method of Mitigation of Technostress

Mitigation	Core Definition	Resources
IT Control	Individuals freely view messages, instead of being forced to ICT intrusive messages	(Galluch et al., 2015); (Salo et al., 2019)
Method Control	Individuals have the right over the method of accomplishing primary tasks.	(Galluch et al., 2015)
Distancing	Implementing the option of disconnecting from the ICT environmental scenarios and engaging in non-ICT activities.	(Galluch et al., 2015); (Tarafdar et al., 2020); (Salo et al., 2019)
Venting	Expressing emotions verbally in stressful events.	(Tarafdar et al., 2020); (Salo et al., 2019)
Positive IT Outlook	Rebuilding stressful situations as positive.	(Tarafdar et al., 2020); (Pflügner et al., 2020)

Source: This study.

### Technostress and the Remote Work Exhaustion

Technostress was originally viewed as a computer-generated health ailment (Brod, 1984). Afterward, technostress expanded into workplaces and considered that it is non-optional leads to changes in organizational performance and individual roles (Tarafdar et al., 2020). As the clear definition of "technostress" is rather intricate, several studies have specifically explained that "technostress" is associated with technology fatigue and technology addiction (Salanova et al., 2013). Remote work is characterized by contact with members of an organization through the use of ICT and computer systems all day, with the ICT panel being the almost and only channel at work, remote workers often experience disruptions (e.g., frequently and explosive text messages), workload loads, and work-family conflict (i.e., the blurring of virtual reality and real reality) (Stich, 2020). Also,

the common characteristics of ICT to result in work exhaustion are technology overload and technology invasion (Ragu-Nathan et al., 2008). Hence, remote work could be regarded as a phenomenon of technology addiction and technology strain.

## METHODOLOGY

This conceptual study is established by reviewing the literature from previous studies, the approach was by searching on academic journal research on Google Scholar such as "the mitigation of Technostress on remote work exhaustion". Nevertheless, not all the studies did match this research interest. Most of the related studies would not target the field of remote work and little connect the relationship between remote work exhaustion, technostress, and mitigating method. Hence, the authors make literature reviews and seek the complicated relation.

### Proposed Propositions and Conceptual Model

The aim of this study is to develop a conceptual model for technostress (Figure 1.) and understand the effect of the proposed early warning mitigation mechanism on the relationship between work exhaustion and technostress. Since the emphasis is on explaining the mitigating role of the early warning mechanism, the authors consider the impact of different early warning times, which can lead to various mental and physical reactions. These variations could result in different levels of remote work exhaustion. Therefore, the research questions are as follows: What are the effects of implementing an early warning mechanism on the computer system in relation to technostress and remote work exhaustion? In the following part, the authors show the development of the proposed propositions.

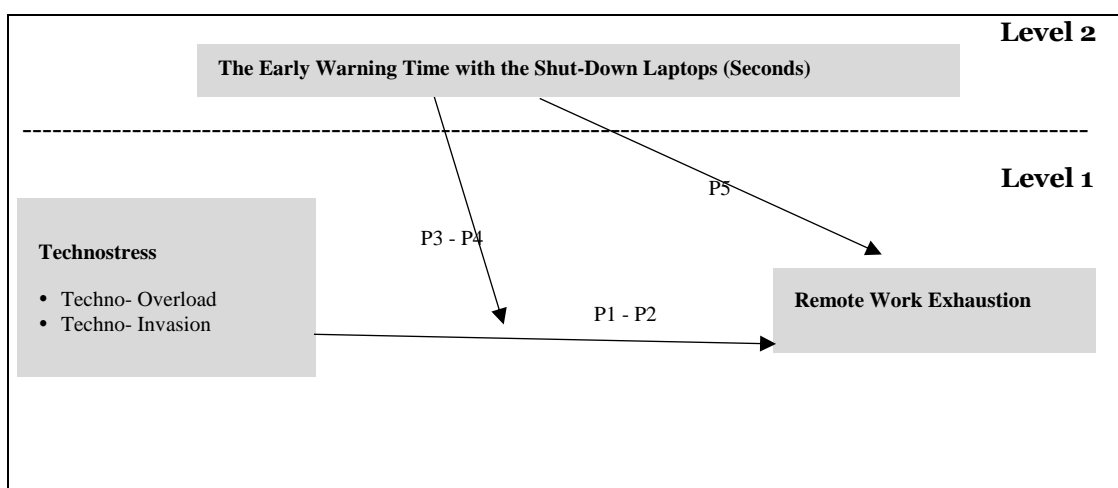

Figure 1: Research Model

Source: This study.

#### **Proposition 1: Techno-overload is positively related to remote work exhaustion.**

During the pandemic, remote workers encountered an elevated risk of exhaustion due to extended working hours and blurred boundaries between work and personal life (Routley; Toniolo-Barrios & Pitt, 2021). While remote work boasts advantages like flexibility and reduced commuting, it also brings about the feeling of being in a perpetual "always on" state (Rudnicka et al., 2020; Shreedhar et al., 2022). This continuous engagement can take a toll on both mental and physical energy (Adisa et al., 2023).

Research has shown a positive correlation between techno-overload and burnout among employees (Srivastava et al., 2015). This finding corroborates the notion that excessive technology usage can amplify burnout and exhaustion, particularly in remote work setups. Also, employees exposed to an overload of technology, such as excessive emails or videoconferencing, are at an elevated risk of experiencing burnout (Bregenzer & Jimenez, 2021; Luce, 2019). Consequently, organizations need to be vigilant about the extent of technology exposure to avert adverse outcomes like burnout and exhaustion.

Additionally, the excessive utilization of technology has been associated with heightened stress levels and diminished job satisfaction in employees (Ingusci et al., 2021; Lai et al., 2015). This insight underscores the importance of organizations being mindful of the quantity of technology exposure. Failing to do so may lead to unfavorable consequences like burnout and exhaustion (Ravindran et al., 2014; Smith et al., 1999).

In conclusion, techno-overload poses a significant risk to remote work, resulting in exhaustion and diminished productivity. It is imperative for organizations to be cognizant of the extent of technology exposure employees face. By proactively managing technology usage, organizations can effectively prevent unfavorable outcomes such as exhaustion and burnout.

#### **Proposition 2: Techno-invasion is positively related to remote work exhaustion.**



Technology invasion refers to the widespread use of technology, particularly digital communication tools and remote work platforms, to permeate traditional workplace boundaries and alter work practices (Lythreathis et al., 2022). In the context of remote work, technology invasion signifies the increasing reliance on technology to enable remote work and blurring the lines between work and personal life, as workers are more interconnected and accessible than ever before (Molino et al., 2020). Technology invasion has a range of effects on remote workers, including enhancing flexibility and productivity but potentially posing risks to mental health and work-life balance (Currie & Eveline, 2011). Importantly, technology invasion is positively correlated with remote work fatigue (Montreuil et al., 2022). A study found that employees who reported higher levels of technology invasion, such as frequent technological disruptions and a deluge of emails, often experienced heightened emotional exhaustion and decreased job satisfaction (Rohwer et al., 2022). Many remote workers report feeling exhausted, with maintaining constant connectivity often cited as a primary source of stress (Van Zoonen & Sivunen, 2022).

***Proposition 3: The early warning time with the shut-down laptops (Seconds) could moderate the effects between techno-overload and remote work exhaustion.***

Technology overload refers to the feeling of being overwhelmed by a constant influx of information and notifications (Molino et al., 2020; Sbaffi et al., 2020). For employees who receive a warning before their computer is about to shut down, they are more likely to save their work and exit programs, thus reducing the risk of data loss and frustration (Neumann, 1994). Additionally, due to the shift towards remote work brought about by the pandemic, the problem of technological overload has become increasingly severe, as individuals struggle to manage the continuous stream of information and communication resulting from virtual collaboration (Williamson et al., 2020). Therefore, providing a warning time when shutting down a laptop can assist individuals in better managing their workload, mitigating the effects of technology overload and remote work exhaustion, ultimately improving their mental and emotional well-being (Mordi et al., 2023). Through the use of early warning mechanisms, one can consciously allocate fixed periods to handle messages, reducing the need for immediate responses.

***Proposition 4: The early warning time with the shut-down laptops (Seconds) could moderate the effects between techno-invasion and remote work exhaustion.***

Techno-invasion can be a significant source of stress for remote workers, especially when employees need to be on call and respond actively throughout the day (Borle et al., 2021; Edú-Valsania et al., 2022). This constant state of connectivity can make it challenging to power down and recharge, ultimately leading to fatigue and burnout. Workers who experience high levels of techno-invasion are more likely to exhibit symptoms of fatigue and job dissatisfaction (Edú-Valsania et al., 2022).

By setting early warning times for laptop shutdown, remote employees could mitigate the issues of continuous technological intrusion into their lives. Many remote workers struggle to disconnect from work-related technology, which can result in fatigue and other adverse outcomes (Lowy, 2020). This underscores the necessity of implementing strategies, such as setting early warning times for laptop shutdown, to assist remote workers in defining clear boundaries and managing their workload effectively (Pflügner et al., 2020).

In conclusion, setting early warning times for laptop shutdown may serve as an effective strategy to alleviate the negative impact of techno-invasion and mitigate remote work exhaustion.

***Proposition 5: The early warning time with the shut-down laptops (Seconds) is negatively related to remote work exhaustion.***

Remote work exhaustion is an increasingly concerning issue for many organizations, as remote employees often find it challenging to disengage from work-related technology and establish clear boundaries between work and personal life (Eddleston & Mulki, 2017; Feldmann, 2022). This can lead to exhaustion and fatigue, negatively impacting both job performance and personal well-being (Costin et al., 2023). Remote work can result in extended working hours, increased stress, and overwhelming fatigue (Schreibauer et al., 2020). By setting alerts for laptop shutdown, remote workers can prioritize their personal lives and recharge, thereby reducing the negative impacts of remote work and preventing burnout (Talent, 2023).

Setting clear boundaries between work and personal life can help remote workers disengage from work and recharge (Park et al., 2011). By setting alerts for laptop shutdown, remote workers can detach from work-related technology and focus on other aspects of life, such as family, friends, and hobbies. In conclusion, there is a negative correlation between laptop shutdown alerts and remote work fatigue. The authors argue that laptop shutdown alerts are defined as the time when computer systems emit warning notifications and prepare to shut down the laptop when employees are engaged in remote work. The authors believe that setting alerts through technological configurations on computer systems to issue warnings at specific times will proactively mitigate or minimize the negative effects of ICT intrusion on remote exhaustion. This suggests that the regular display of overtime notifications will maximize the reduction of ICT intrusion's negative impact on remote exhaustion. Due to the lack of physical interaction with colleagues during remote work, the authors suggest that employees may remain glued to the computer interface (e.g., online shopping or work tasks). In such cases, the longer the computer system is in use, the higher the level of technological stress. Subsequently, this can lead to significant remote work fatigue. It is important to emphasize that employees can obtain overtime information through alert settings, regardless of whether they decide to immediately disengage from IT devices.

#### PRATICAL DESIGN

The authors have designed a practical solution to automatically initiate a shutdown on employee computers by utilizing the Windows Task Scheduler (Figure 2 ~ Figure 10). This system functions by executing the command 'shutdown -s -t 100' to initiate

an automatic shutdown after a brief 100-second interval. While this may be an effective approach to ensuring employees adhere to rest schedules, the authors posit that increasing the duration of the warning period could be a more advantageous alternative. By extending the warning period, employees would have more time to effectively prepare for rest, such as saving their work or making note of important deadlines before their computer shuts down. Furthermore, increasing the warning time can help mitigate the stress and anxiety caused by abrupt shutdowns, thereby promoting a more relaxed and productive work environment. Overall, while the current notification system is a functional step toward promoting adequate rest for employees, increasing the warning time is a more effective solution to ensure employees have sufficient time to prepare for rest.

Figure 2 provides a clear depiction of the implementation of an early warning system within a computing environment.



Figure 2: Task Scheduler

Figure 3 provides a concise depiction of the steps required to enable a warning time announcement within the computing environment.

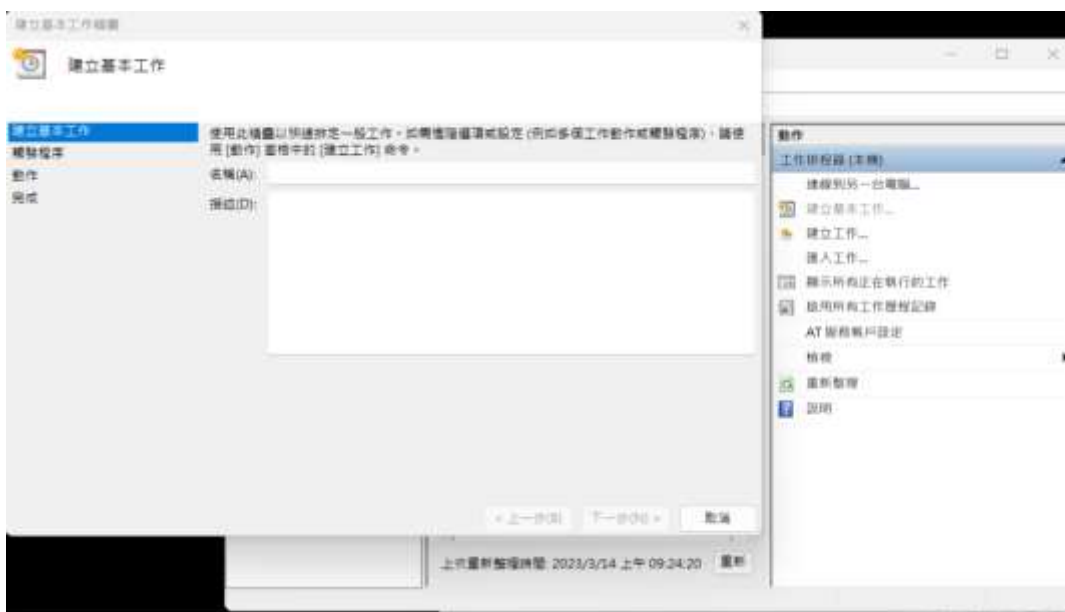

Figure 3: Prepare Schedule

Figure 4 provides a clear depiction of the announcement of the early warning system. This announcement is a crucial aspect of the early warning system as it informs users of impending system shutdowns, enabling them to save their work and take necessary measures to minimize the impact of the shutdown.

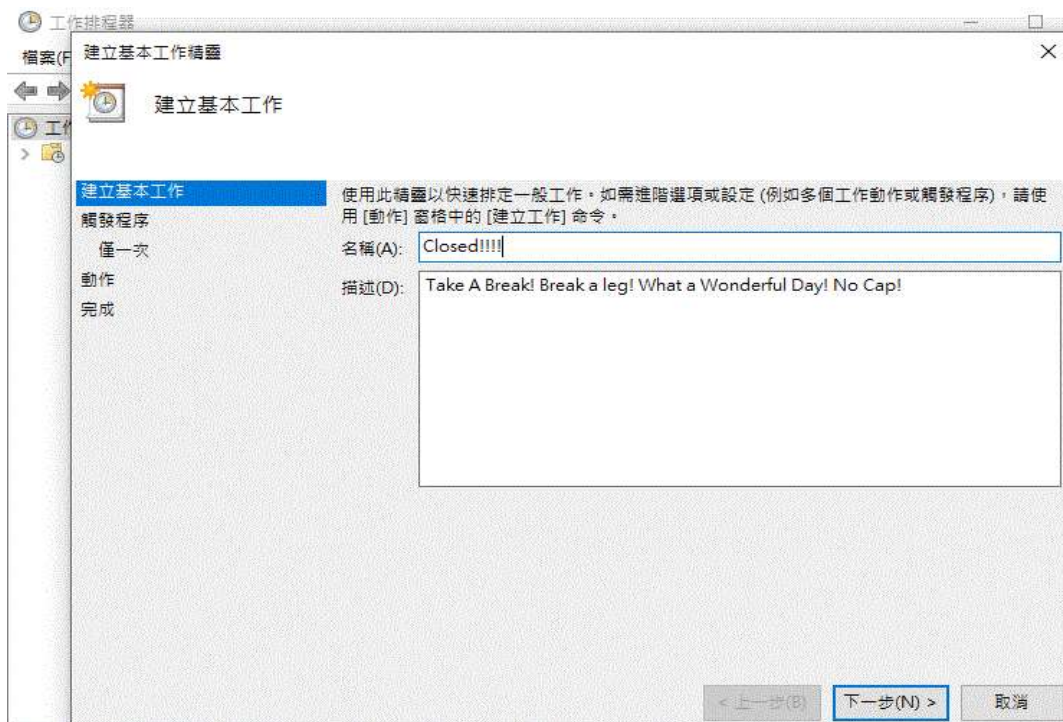

Figure 4: Set Schedule

Figure 5 provides a clear depiction of the number of early warning system activations. This information can be used by system administrators and users to gain insights into the frequency and timing of system shutdowns and take appropriate measures to minimize their impact. Figure 6 depicts the versatility of the early warning system, highlighting that it can be configured according to the day, week, month, and working time of remote users. This level of customization enables companies to tailor the system settings to the unique needs of their workforce, thereby ensuring that users receive timely notifications of impending system shutdowns.

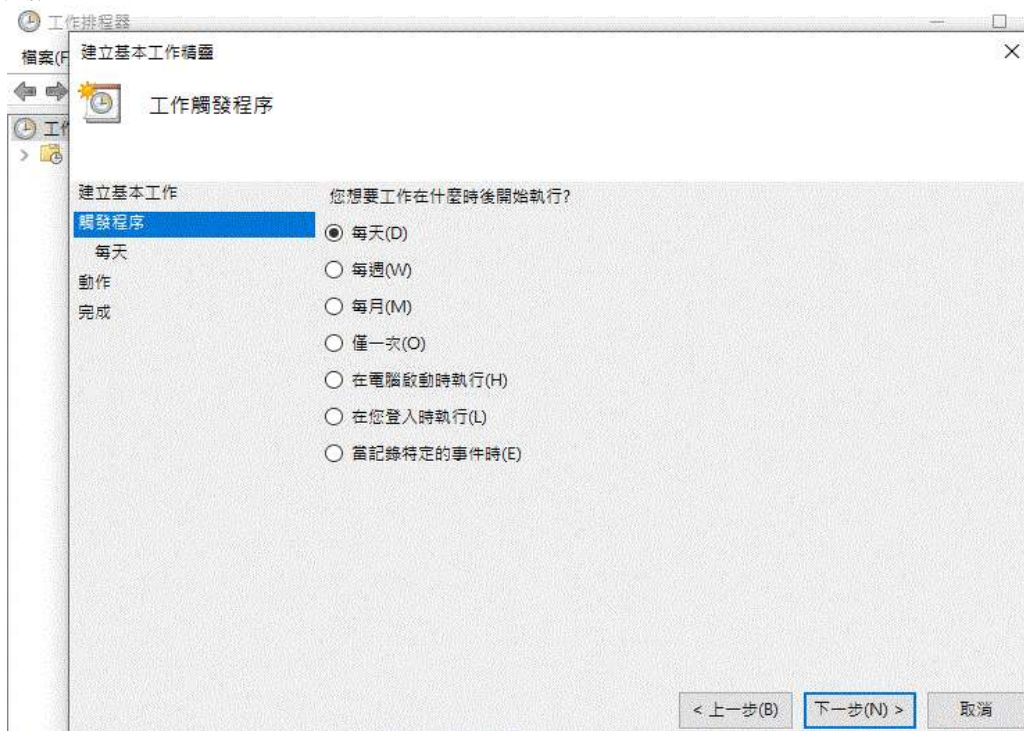

Figure 5: Set the start Time of the Early Warning Mechanism-1



Figure 6 depicts this relationship and emphasizes the importance of ensuring that the early warning system is activated at an appropriate time to ensure that users receive timely notifications in the event of system shutdowns.

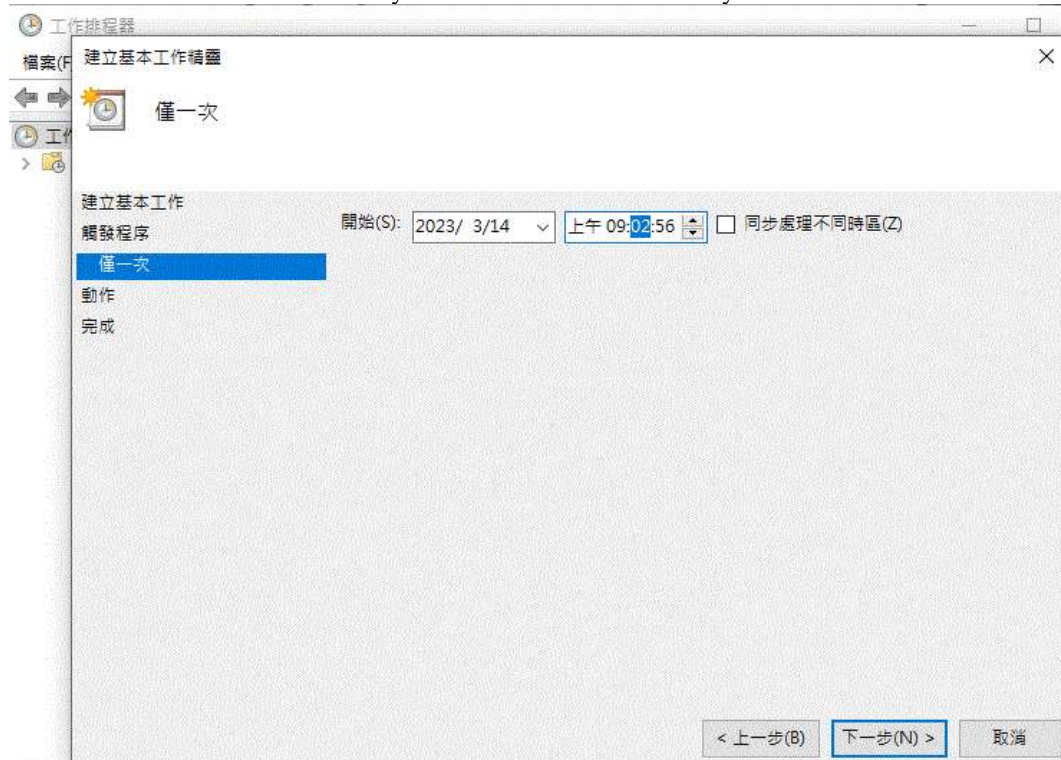

Figure 6: Set the start Time of the Early Warning Mechanism-2

Figure 7 illustrates the process of activating the early warning system by selecting the "Start Program" option.

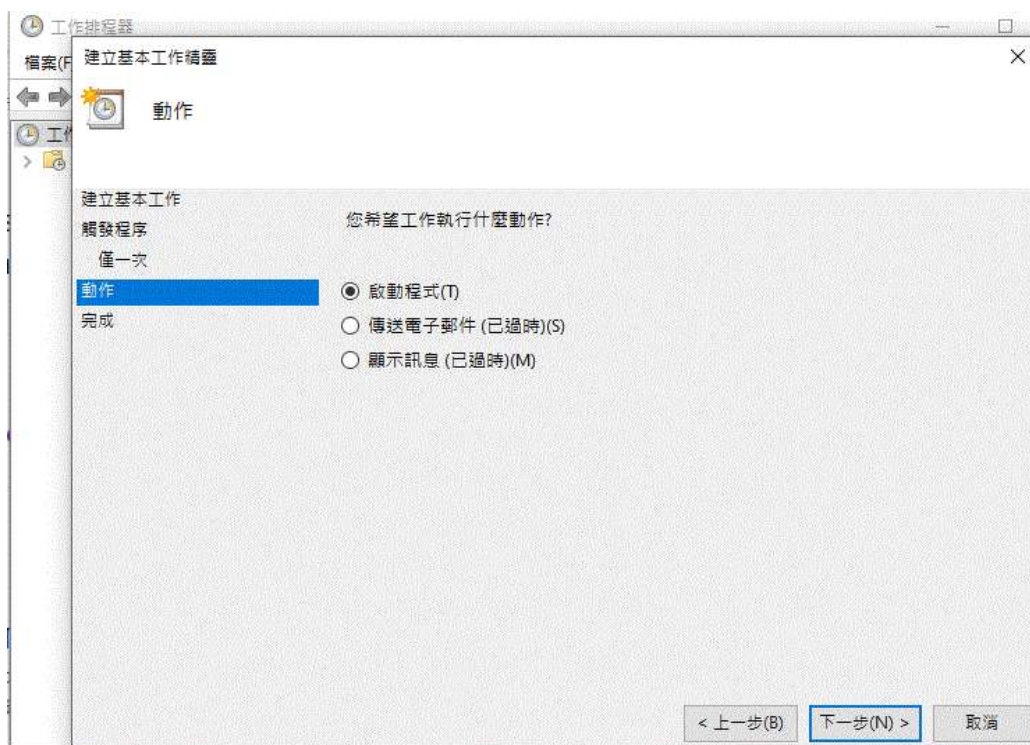

Figure 7: Activate the Schedule

Figure 8 reveal that the warning mechanism has been configured to operate for a duration of 100 seconds. This duration can be activated by executing the "**shutdown -s -t ()**" command, whereby the user specifies the desired time interval in seconds using the parameter within the parenthesis. This configuration allows users to effectively manage the system's shutdown process, thus ensuring that the shutdown operation is carried out in a controlled and orderly manner.

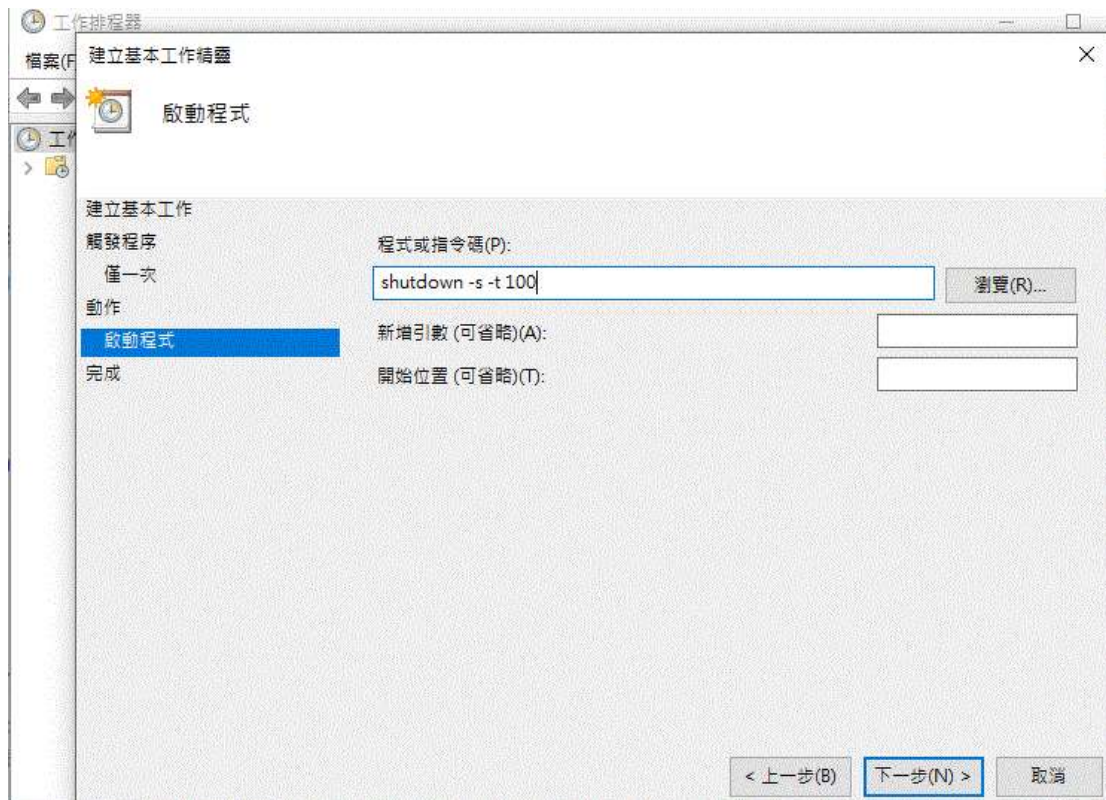

Figure 8: Set the Time Duration of the Warning System

Figure 9 illustrates the graphical user interface (GUI) used by organizations and individuals to configure the early warning mechanism for their employees' computers. This interface enables users to tailor the early warning system to the specific needs of their employees/firms, ensuring that they receive timely alerts before any impending system shutdowns.

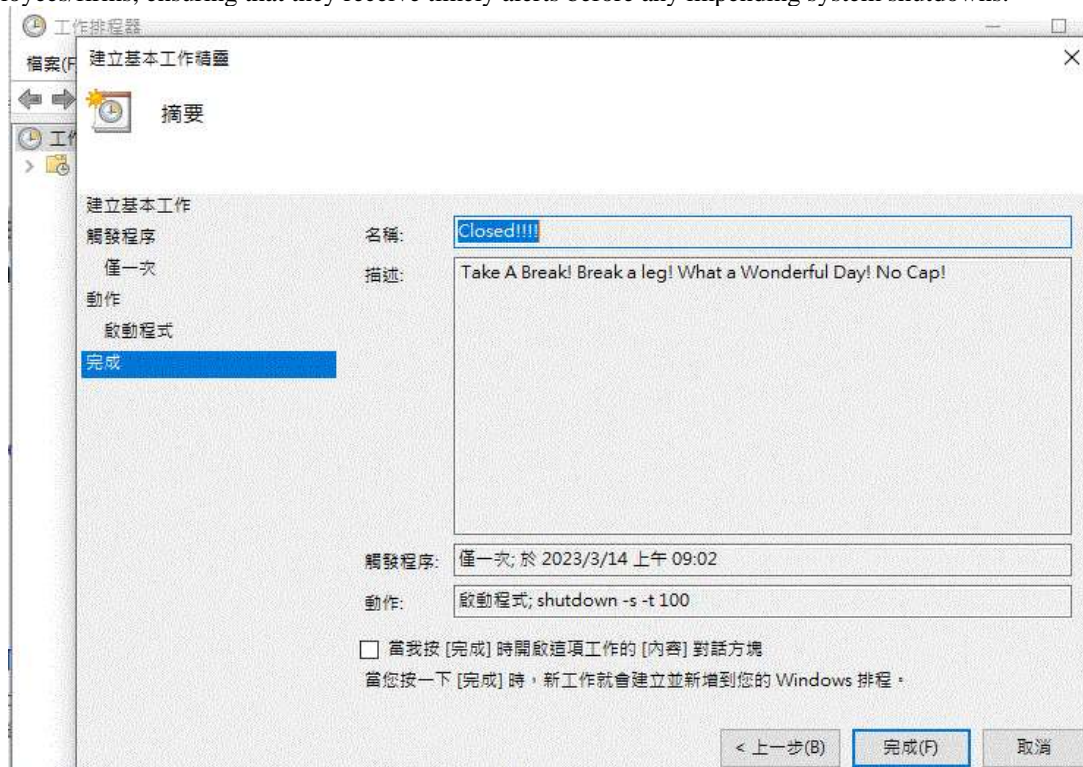

Figure 9: Set the Time Duration of the Warning System

Figure 10 provides a clear depiction of the interface encountered by a teleworker using the early warning system during office work. This figure highlights the importance of setting appropriate warning times to effectively relieve the technological pressure experienced by remote workers. The depiction of the warning system interface in Figure 10 serves as a useful reference for system administrators seeking to optimize the effectiveness of the early warning system and enhance the well-being of remote workers.



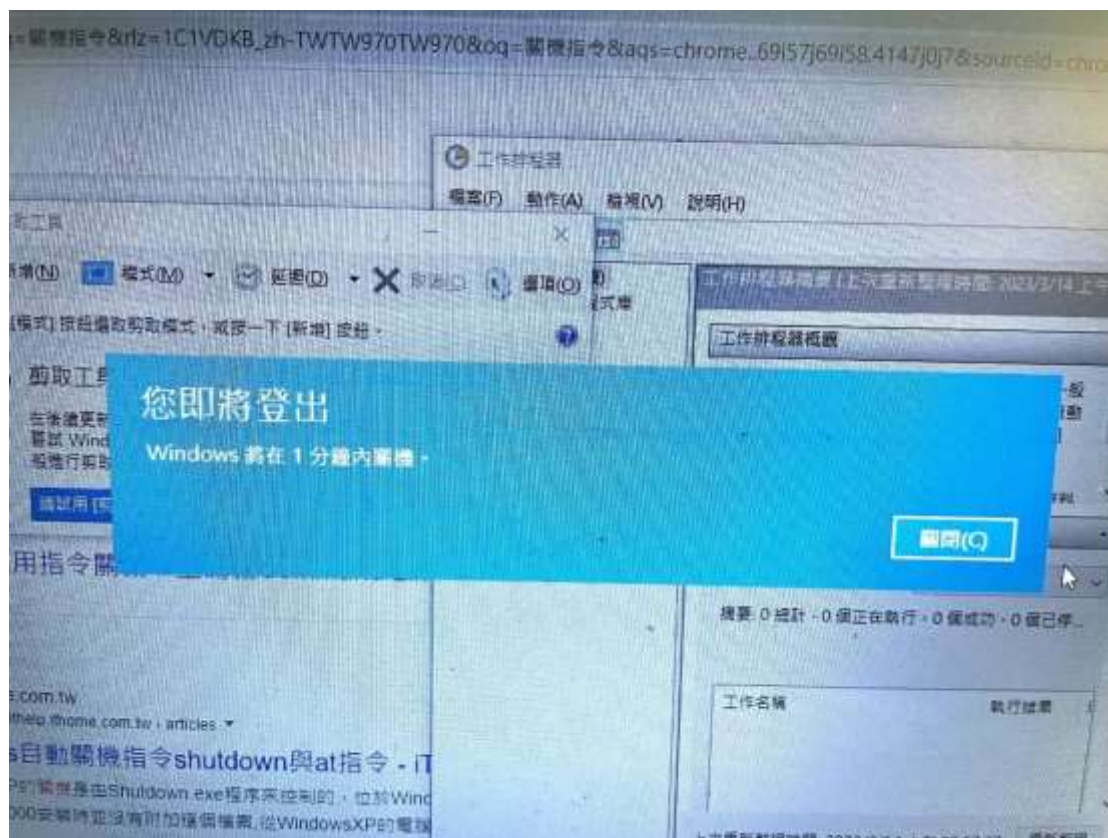

Figure 10: Actual Early Warning Mechanism

## CONCLUSIONS

The primary objective of this study is to introduce an innovative model designed to provide a comprehensive approach for addressing technostress and effectively mitigating its impact. To achieve this, a thorough literature review was conducted, aiding in the conceptual development of this paper. The review of existing contributions revealed that technostress mitigation has historically been approached through two main avenues: human-oriented strategies (Tindle et al., 2022) and technology-mediated interventions (Brivio et al., 2018).

Human-oriented strategies encompass various aspects such as social support, personality traits, cultivating a positive attitude, active participation, and engaging in spoken venting (Weinert et al., 2020). These mechanisms recognize the essential role of human interactions and psychological factors in managing technostress. On the other hand, technology-mediated interventions involve strategies like IT control, maintaining a physical and psychological distance from technology, and method control. These approaches acknowledge the potential of technological tools to regulate and alleviate technostress.

Theoretical perspectives from scholars like Matthieu and Ivanoff (2006) characterize stress as the point at which an individual's personal perception of strain reaches a threshold level (Matthieu & Ivanoff, 2006). This notion suggests that individuals take action or communicate distress signals when their stressors exceed this threshold. Notably, the remote work environment often fosters isolation, hindering effective communication of technostress. This is particularly relevant in the context of the COVID-19 pandemic, where information and communication technologies (ICT) have become integral to various aspects of life, including remote work interfaces and communication devices like phones.

In light of these considerations, the severity of technostress has become particularly pronounced during the pandemic era, where ICT has pervaded every facet of daily life. The inevitability of relying on these technologies is evident. Despite attempts to distance oneself from them, previous research highlights that complete mitigation of technostress through IT distancing is not always feasible (Salo et al., 2022). Even when individuals endeavor to distance themselves from technology, negative technostress may persist. Thus, a more direct approach involving the shutdown of IT devices, such as laptops, becomes necessary.

This approach circumvents the potential challenges posed by personal technology addiction and willpower limitations. Interestingly, a prevalent characteristic observed among remote employees is the constant influx of online messages coupled with the simultaneous completion of tasks. Abruptly shutting down an IT device in such scenarios can evoke feelings of annoyance among remote employees. To address this, a novel and balanced mechanism is proposed, allowing remote employees a designated period to prepare for the planned shutdown of their IT devices. This thoughtful approach ensures that individuals have sufficient time to transition and minimizes the disruption caused by sudden shutdowns.

The implications of this novel approach are substantial. Beyond its immediate application, it holds promise for shaping the future of remote work systems and influencing product design strategies for manufacturers. Moreover, it underscores the potential for organizations to take a proactive role in safeguarding the well-being of remote employees. By integrating such mechanisms, firms can demonstrate their commitment to managing employee health and enhancing the overall work experience.

In conclusion, this study not only sheds light on the multifaceted nature of technostress and its management but also introduces an innovative solution tailored to the unique challenges of the remote work landscape, especially in the context of heightened ICT reliance during the COVID-19 pandemic. The proposed mechanism not only benefits individuals but also presents opportunities for organizations to refine their approach to remote work and employee well-being.

### LIMITATIONS AND FUTURE RESEARCH

This study includes several limitations, which in turn creates avenues for future studies. First, the authors proposed an innovative idea, but it is unclear how much the effectiveness of the warning mechanism affects the mitigating effects between technostress and work exhaustion. Future scholars might examine this conceptual model by empirical analysis. Second, there is limited mitigation of remote work studies to identify the factors. Consequently, future scholars might offer various insights for effective technostress mitigation for remote work exhaustion.

### REFERENCES

- Adisa, T. A., Ogbonnaya, C., & Adekoya, O. D. (2023). Remote working and employee engagement: a qualitative study of British workers during the pandemic. *Information Technology & People*, 36(5), 1835-1850.
- Borle, P., Reichel, K., Niebuhr, F., & Voelter-Mahlknecht, S. (2021). How are techno-stressors associated with mental health and work outcomes? A systematic review of occupational exposure to information and communication technologies within the technostress model. *International Journal of Environmental Research and Public Health*, 18(16), 8673.
- Bregenzler, A., & Jimenez, P. (2021). Risk factors and leadership in a digitalized working world and their effects on employees' stress and resources: Web-based questionnaire study. *Journal of medical Internet research*, 23(3), e24906.
- Brivio, E., Gaudioso, F., Vergine, I., Mirizzi, C. R., Reina, C., Stellari, A., & Galimberti, C. (2018). Preventing technostress through positive technology. *Frontiers in psychology*, 9, 2569.
- Brod, C. (1984). *Technostress: The human cost of the computer revolution*. Reading, Mass.: Addison-Wesley.
- Costin, A., Roman, A. F., & Balica, R.-S. (2023). Remote work burnout, professional job stress, and employee emotional exhaustion during the COVID-19 pandemic. *Frontiers in psychology*, 14, 1193854.
- Currie, J., & Eveline, J. (2011). E-technology and work/life balance for academics with young children. *Higher Education*, 62, 533-550.
- Edú-Valsania, S., Laguía, A., & Moriano, J. A. (2022). Burnout: A review of theory and measurement. *International Journal of Environmental Research and Public Health*, 19(3), 1780.
- Eddleston, K. A., & Mulki, J. (2017). Toward understanding remote workers' management of work–family boundaries: The complexity of workplace embeddedness. *Group & Organization Management*, 42(3), 346-387.
- Estrada-Muñoz, C., Vega-Muñoz, A., Castillo, D., Müller-Pérez, S., & Boada-Grau, J. (2021). Technostress of Chilean Teachers in the Context of the COVID-19 Pandemic and Teleworking. *International Journal of Environmental Research and Public Health*, 18(10), 5458.
- Feldmann, J. (2022). *The Importance Of Separating Work And Personal Life In A Remote Environment*. Forbes. Retrieved October 11 from <https://www.forbes.com/sites/forbeshumanresourcescouncil/2022/01/18/the-importance-of-separating-work-and-personal-life-in-a-remote-environment/?sh=4160d8a246c8>
- Gabr, H. M., Soliman, S. S., Allam, H. K., & Raouf, S. Y. A. (2021). Effects of remote virtual work environment during COVID-19 pandemic on technostress among Menoufia University Staff, Egypt: A cross-sectional study. *Environmental Science and Pollution Research*, 28(38), 53746-53753.
- Galluch, P. S., Grover, V., & Thatcher, J. B. (2015). Interrupting the workplace: Examining stressors in an information technology context. *Journal of the Association for Information Systems*, 16(1), 2. <https://doi.org/10.17705/1jais.00387>
- Ingusci, E., Signore, F., Giancaspro, M. L., Manuti, A., Molino, M., Russo, V., Zito, M., & Cortese, C. G. (2021). Workload, techno overload, and behavioral stress during COVID-19 emergency: The role of job crafting in remote workers. *Frontiers in psychology*, 12, 655148.
- Kniffin, K. M., Narayanan, J., Anseel, F., Antonakis, J., Ashford, S. P., Bakker, A. B., Bamberger, P., Bapuji, H., Bhawe, D. P., & Choi, V. K. (2021). COVID-19 and the workplace: Implications, issues, and insights for future research and action. *American psychologist*, 76(1), 63.
- Lai, Y., Saridakis, G., & Blackburn, R. (2015). Job stress in the United Kingdom: Are small and medium-sized enterprises and large enterprises different? *Stress and Health*, 31(3), 222-235.
- Lazarus, R. S. (1966). Psychological stress and the coping process.
- Lazarus, R. S., & Folkman, S. (1984). *Stress, appraisal, and coping*. Springer publishing company.
- Lowy, J. (2020). *Overcoming Remote Work Challenges*. Retrieved October 12 from <https://sloanreview.mit.edu/article/overcoming-remote-work-challenges/>
- Luce, I. D. (2019). *Why meetings, email, and 'excessive collaboration' are the unholy trinity of burnout*. Retrieved August 26 from <https://www.businessinsider.com/excessive-collaboration-leads-to-burnout-and-hurts-productivity-2019-6>
- Lythreathis, S., Singh, S. K., & El-Kassar, A.-N. (2022). The digital divide: A review and future research agenda. *Technological Forecasting and Social Change*, 175, 121359.



- Matthieu, M. M., & Ivanoff, A. (2006). Using stress, appraisal, and coping theories in clinical practice: Assessments of coping strategies after disasters. *Brief treatment and crisis intervention*, 6(4), 337.
- Mheidly, N., Fares, M. Y., Zalzale, H., & Fares, J. (2020). Effect of face masks on interpersonal communication during the COVID-19 pandemic. *Frontiers in Public Health*, 8, 898.
- Molino, M., Ingusci, E., Signore, F., Manuti, A., Giancaspro, M. L., Russo, V., Zito, M., & Cortese, C. G. (2020). Wellbeing costs of technology use during Covid-19 remote working: An investigation using the Italian translation of the technostress creators scale. *Sustainability*, 12(15), 5911. <https://doi.org/10.3390/su12155911>
- Montreuil, V.-L., Dextras-Gauthier, J., Gilbert, M.-H., Dima, J., & Boulet, M. (2022). Remote work during the COVID-19 pandemic: How do digital technology use affects mental fatigue, psychological distress and well-being? *Safety and Health at Work*, 13, S166.
- Mordi, C., Ajonbadi, H. A., & Adekoya, O. D. (2023). Technology infiltration: permeable boundaries and work–life spillover experiences among academics in the United Kingdom during the COVID-19 pandemic. *Personnel Review*.
- Mukherjee, S., & Narang, D. (2023). Digital economy and work-from-home: The rise of home offices amidst the COVID-19 outbreak in India. *Journal of the Knowledge Economy*, 14(2), 924-945.
- Neumann, P. G. (1994). *Computer-related risks*. Addison-Wesley Professional.
- Oksanen, A., Oksa, R., Savela, N., Mantere, E., Savolainen, I., & Kaakinen, M. (2021). COVID-19 crisis and digital stressors at work: A longitudinal study on the Finnish working population. *Computers in Human Behavior*, 122, 106853.
- Park, Y., Fritz, C., & Jex, S. M. (2011). Relationships between work-home segmentation and psychological detachment from work: the role of communication technology use at home. *Journal of occupational health psychology*, 16(4), 457.
- Pflüger, K., Reis, L., Maier, C., & Weitzel, T. (2020). Communication measures to reduce techno-invasion and techno-overload: a qualitative study uncovering positive and adverse effects. Proceedings of the 2020 on computers and people research conference,
- Pirkkalainen, H., Salo, M., Makkonen, M., & Tarafdar, M. (2017). Coping with technostress: When emotional responses fail. International Conference on Information Systems,
- Ragu-Nathan, T., Tarafdar, M., Ragu-Nathan, B. S., & Tu, Q. (2008). The consequences of technostress for end users in organizations: Conceptual development and empirical validation. *Information systems research*, 19(4), 417-433.
- Ravindran, T., Yeow Kuan, A. C., & Hoe Lian, D. G. (2014). Antecedents and effects of social network fatigue. *Journal of the Association for Information Science and Technology*, 65(11), 2306-2320.
- Reinke, K., Gerlach, G., Tarafdar, M., & Stock, R. M. (2016). ICT-based communication events as triggers of stress: A mixed methods study.
- Rohwer, E., Flöther, J.-C., Harth, V., & Mache, S. (2022). Overcoming the “Dark Side” of Technology—A scoping review on preventing and coping with work-related technostress. *International Journal of Environmental Research and Public Health*, 19(6), 3625.
- Routley, N. Charts that show what employers and employees really think about remote working. World Economic Forum and Visual Capitalist (2021),
- Ru-zhe, J., & Agmapisarn, C. (2023). COVID-19, Resilience, Job Satisfaction and Organisational Citizenship Behaviour Among Hotel Employees After Thailand’s Reopening Plan: A Moderated Mediation Model. *Thammasat Review*, 26(1), 57-91.
- Rudnicka, A., Newbold, J. W., Cook, D., Cecchinato, M. E., Gould, S., & Cox, A. L. (2020). Eworklife: Developing effective strategies for remote working during the COVID-19 pandemic. *Eworklife: developing effective strategies for remote working during the COVID-19 pandemic*,
- Salanova, M., Llorens, S., & Cifre, E. (2013). The dark side of technologies: Technostress among users of information and communication technologies. *International journal of psychology*, 48(3), 422-436.
- Salo, M., Pirkkalainen, H., Chua, C. E. H., & Koskelainen, T. (2022). Formation and mitigation of technostress in the personal use of IT. *Mis Quarterly*, 46. <https://doi.org/10.25300/MISQ/2022/14950>
- Salo, M., Pirkkalainen, H., & Koskelainen, T. (2019). Technostress and social networking services: Explaining users' concentration, sleep, identity, and social relation problems. *Information Systems Journal*, 29, 408-435. <https://doi.org/10.1111/isj.12213>
- Sbaffi, L., Walton, J., Blenkinsopp, J., & Walton, G. (2020). Information overload in emergency medicine physicians: a multisite case study exploring the causes, impact, and solutions in Four North England national health service trusts. *Journal of medical Internet research*, 22(7), e19126.
- Schreibauer, E. C., Hippler, M., Burgess, S., Rieger, M. A., & Rind, E. (2020). Work-related psychosocial stress in small and medium-sized enterprises: an integrative review. *International Journal of Environmental Research and Public Health*, 17(20), 7446.
- Shreedhar, G., Laffan, K., & Giurge, L. (2022). Is remote work actually better for the environment? *Harvard Business Review*.
- Smith, M. J., Conway, F. T., & Karsh, B.-T. (1999). Occupational stress in human computer interaction. *Industrial health*, 37(2), 157-173. <https://doi.org/10.2486/indhealth.37.157>
- Srivastava, S. C., Chandra, S., & Shirish, A. (2015). Technostress creators and job outcomes: theorising the moderating influence of personality traits. *Information Systems Journal*, 25(4), 355-401.
- Stich, J.-F. (2020). A review of workplace stress in the virtual office. *Intelligent Buildings International*, 12(3), 208-220. <https://doi.org/10.1080/17508975.2020.1759023>
- Talent, S. (2023). *How to Effectively Manage Your Time and Prioritize Tasks When Working Remotely*. Simera. Retrieved October 11 from <https://blog.simera.io/how-to-manage-time-and-prioritize-when-working-remotely>
- Tarafdar, M., D’arcy, J., Turel, O., & Gupta, A. (2014). The dark side of information technology. *MIT Sloan Management Review*.

- Tarafdar, M., Pirkkalainen, H., Salo, M., & Makkonen, M. (2020). Taking on the “dark side”—Coping with technostress. *IT professional*, 22(6), 82-89. <https://doi.org/10.1109/MITP.2020.2977343>
- Tindle, R., Hemi, A., & Moustafa, A. A. (2022). Social support, psychological flexibility and coping mediate the association between COVID-19 related stress exposure and psychological distress. *Scientific Reports*, 12(1), 8688.
- Toniolo-Barrios, M., & Pitt, L. (2021). Mindfulness and the challenges of working from home in times of crisis. *Business horizons*, 64(2), 189-197.
- Van Zoonen, W., & Sivunen, A. E. (2022). The impact of remote work and mediated communication frequency on isolation and psychological distress. *European Journal of Work and Organizational Psychology*, 31(4), 610-621.
- Weinert, C., Maier, C., Laumer, S., & Weitzel, T. (2014). Does teleworking negatively influence IT professionals? An empirical analysis of IT personnel's telework-enabled stress. Proceedings of the 52nd ACM conference on Computers and people research,
- Weinert, C., Maier, C., Laumer, S., & Weitzel, T. (2020). Technostress mitigation: An experimental study of social support during a computer freeze. *Journal of Business Economics*, 90, 1199-1249.
- Williamson, B., Eynon, R., & Potter, J. (2020). Pandemic politics, pedagogies and practices: digital technologies and distance education during the coronavirus emergency. In (Vol. 45, pp. 107-114): Taylor & Francis.

## Online Learning Experiences and Resilience in Higher Education Students: Evidence from India

Rupali <sup>1,\*</sup>  
Paritosh Mishra <sup>2</sup>  
Balvinder Shukla <sup>3</sup>

\*Corresponding author

<sup>1</sup> Amity Business School, Amity University Uttar Pradesh, Noida, India, Research Scholar, rupali.kumar97@gmail.com

<sup>2</sup> Amity Business School, Amity University Uttar Pradesh, Noida, India, Professor, pmishra@amity.edu

<sup>3</sup> Amity University Uttar Pradesh, Noida, India, Professor, bshukla@amity.edu

### ABSTRACT

Due to significant disparities in the digital foundation, the social and economic position of students, the pedagogical framework, and the skill deficiencies of staff and instructors, the COVID-19 pandemic has generated specific issues in the education sector for both developed and developing nations. The capacity of students to succeed in online learning environments is highly influenced by resilience. It aids pupils in overcoming challenges, remaining motivated, managing their time, adapting to changes, and preserving their emotional wellbeing. The authors want to understand the levels of resilience in higher education students in India during the COVID-19 and explore its connection to students' experiences in online learning environments enrolled in graduate and postgraduate degrees, whose ages ranged from 18 to 28, which made up the study sample. To investigate gender variation in resilience levels independent t-test was utilized and to study the link between resilience scores and the online learning experience of students, correlation analysis has been used. According to the results of the current study, there is a significant gender variation in resilience scores and the resilience levels were positively and strongly connected with availability of resources, comfortability, satisfaction and perceived quality. Findings of the present research can help educational institutions focus on enhancing resilience for better learning during troubled times.

*Keywords:* Resilience, Online learning, Online learning experience, COVID-19, Higher Education, Students, Gender

### INTRODUCTION

The world witnessed spread over of novel coronavirus (COVID-19) with the onset of the third decade of the twenty-first century which forced educational organizations to temporarily close their doors and move to online learning mode. More than 1.57 billion pupils were perforce dropped out of school consequent to COVID. "The COVID-19 pandemic has been the worst shock to education systems in a century" (UNESCO, 2020). In March 2020, India had imposed a lockdown for 21 days which was later extended. In April 2021, India saw one of the worst second wave of COVID-19 cases in the world which compelled Centre and State Governments to call for universities and educational institutions to transition to online learning. Online learning occurs over the internet with the use of technological innovations. It is a teaching-learning strategy that relies more on students, resulting in synchronous or asynchronous learning experiences via devices and internet connectivity (Dhawan, 2020). These measures were surely needed for the safety of students, teachers and every individual involved. However, due to the unprecedented nature of the current shift, educational institutes were not adequately prepared with appropriate systems for online learning. This shift from face-to-face learning to on-the-screen learning has generated several problems at university and student level all around the world. The mass transition from conventional means to new age online learning has forced an unmatched effect on students. Since, the start of the outbreak, students of higher education have been under a tremendous amount of stress, be it survival or academic performance succeed (Waxman et al., 2003). Covid-19 has created unique challenges in their education sector for both developed and developing countries due to major gaps in digital foundation, social and economic status of students, pedagogical structure and skill deficiency of staff and teachers.

In India, there is a clear digital discrepancy in the country due to the lack of infrastructure, internet and technology accessibility, internet connectivity issues, and often scarcity of support from parents and educational institutions (Rahana et al., 2021). Various issues such as lack of certainty about the future, fear of exposure to disease, lack of technological skills, internet issues and insufficient training of staff in handling digital tools, have propelled students to face difficulties in online learning. This leads to educational as well as psycho-emotional related effects on student learning (Quintiliani et al., 2022). Under such situations, students' resilience capabilities play an enormous role. Resilience is the process of developing new abilities or capacity to manage major stressors as a result of a challenging, disruptive, stressful, or demanding life experience. Resilient individuals "bounce back" from challenging situations. Resilience does not only mean surviving, but also thriving in adversity as well (Brewer, et al., 2019). A student with high resilience can manage and adapt to his/her situation faster and better than students with low resilience. This personality trait can therefore be extremely helpful in the current turbulent situation and can increase the effectiveness of

academic programs. Several studies over the years have shown strong connection between resilience and academic performance and success (Ahmed & Julius, 2015). Moreover, previous studies have established on the relation between resilience and students' career aspects like decision-making, success and performance (Clohessy et al., 2019). Resilience is linked to long-term viability and can help students of higher education succeed (Waxman et al., 2003). It also has an impact on students' employability and preparation for the workplace (Clohessy et al., 2019). The benefits of resilient techniques can be seen in areas like social science, medicine and personal development. Therefore, the importance of resilience in students during the pandemic is clear.

Some previous studies have analysed resilience levels in a sample population of Spain and studied the factors of resiliency on various socio-demographic variables (Román-Mata, et al., 2020; Sarmiento, Ponce, & Bertolín, 2021). Oducado, Parreño-Lachica, and Rabacal (2021) have explored resilience and its associations with fear, anxiety and stress among students of higher education against the background of the pandemic. Academic resilience has shown to increase academic achievement even amid adversities (Waxman et al., 2003). Biswas (2021) has studied resilience in Indian college students similar to the present study, but the data collection was done during January to April'19 and thus was in pre-COVID times and has found that there is a disparity among the resilience levels of gender. Females have displayed higher level of resilience than men. Conversely, Chow, Tang, Tang, & Leung (2020) have not find any significant difference in resilience among gender. These inconsistent findings might be attributable to the limited and homogeneous sample sizes of the studies. Thus, even though some research has been done on variables such as resilience and gender, none seems to have been carried out in the arena of online study and with sample drawn from India during the pandemic. Whilst the COVID-19 epidemic in India is still ongoing, a study to understand resilience among higher education students in India during online learning is yet to be completed. Through this study the authors aim to understand about the resilience levels in students of higher education in India during the pandemic and examine the relationship between students' resilience and online learning experience. By understanding the resilience in students of higher learning, educational institutions and organizations in India can make better plans and accordingly take decisions in the future.

## REVIEW OF LITERATURE

### Resilience

Resilience has been studied extensively over the years and several definitions have been given over time. The concept of resilience has been approached from various angles in the past, some define it as an interlinkage of protective factors in face of traumatic circumstances and some as the process of being competent, despite adversity (Luthar et al., 2000). However, there is dearth of commonly recognized definition for resilience. Resilience is also defined as "A dynamic process of positive adaptation in the face of adversity or challenge" (Brewer et al., 2019, p. 10). It is therefore an internal process of pushing oneself and possessing an internal drive to adapt and bounce back when facing challenges in the environment.

It is known that resilience can be encouraged through protective factors such as opportunities for growth, caring environment, supportive adults and peers and self-efficacy. It is influenced by risk factors which might be internal such as individual behaviour and personality or external such as family and environment (Howard et al., 2015). Research by Lee *et al.* (2013) based on meta-analytic methodology stated that improving resilience through strengthening protective characteristics such as self-efficacy, optimism and self-esteem is more successful than reducing risk factors such as depression and anxiety. In all situations, resilience is regarded as a desired quality of adaptability and malleability that impacts an individual's overall health as well as performance.

### Resilience in Students

Students who perform exceedingly well even when they are not expected to because of uncertain and difficult situations are considered to be resilient (Chow et al., 2020). Resilience in students has been a topic of interest for researchers for a while. Several reviews of existing literature have pointed out the role of resilience in academics, especially in higher education. It assists students in addressing the obstacles and helps in their education as well as in management of their mental health (Reyes et al., 2015). A recent study has also revealed that resilience among students can be an excellent coping skill while in confinement (Labrague & Ballard, 2021). Resilient youngsters are known to have a high degree of independence, empathy, goal clarity, curiosity, improved peer connections, and problem-solving abilities.

Numerous negative emotions such as fear, anxiety, lack of certainty and stress have increased in students during the lockdown (Oducado et al., 2021). Resilience can help individuals in overcoming challenges and managing stress (Brewer, et al., 2019). It can help manage their mental health better with less likelihood of anxiety and depression (Rahana et al., 2021). In a study by Ye *et al.* (2020), conducted in China with college students during the pandemic, it has been found that resilience is one of the mediating factors between stressful experiences and Acute Stress Disorder and could help alleviate Acute Stress Disorder. Some studies conducted during the pandemic have shown gender related differences in the degree of fear, fatigue (Labrague & Ballard, 2021), anxiety and depression and resilience (Román-Mata et al., 2020).

### Online Learning During COVID-19

COVID-19 has been a distressing experience for most individuals which has impacted not only their physical health, but mental health as well. Several studies have been carried out since the onset of the pandemic to evaluate the impact of COVID-19 on online learning in various countries. Students' perception towards preparation for online learning is a critical factor in determining whether online learning can function well during a pandemic (Ramadhan, et al., 2021). The negative and positive perceptions towards online learning among students have been established in earlier studies. Some researchers have pointed out that online learning has resulted in high level of satisfaction among students and faculty due to its flexible nature, increased

personal time and the pedagogy used. However, on the contrary some studies have revealed problems faced in adapting to online learning such as lack of interaction, difficulties in maintaining attention, stress of academic performance (Quintiliani et al., 2022; Zhou & Zhang, 2021).

Confinement during the pandemic impacts the academic and psychological performance of students and resilience plays a vital role in the lives of students (Lozano-Díaz et al, 2020). Appolloni *et al.* (2021) avers that resilience is a protective element that fosters in confinement conditions helping the mental conditions of students. Therefore, when it comes to promoting resilience for students, higher education providers have faced problems in creating the online settings and technology infrastructure. Naidu (2021) has pointed out that resilience in students is affected by design and execution of an online learning course. Resource availability such as internet connectivity, technical devices and online resources can severely impact the success of online learning (Kohan, et al., 2017). Availability of such resources to both faculty as well as students are crucial in enhancing online learning has been well studied. According to Alzahrani and O'toole's (2017) research, students who owned internet devices had much more favourable views towards adopting online learning opportunities. Segbenya *et al.* (2022) found that irregular internet access and power supply had an influence on the desire to keep using online learning. By leveraging such resources students can acquire information and support for what they need. Since, students who frequently use technology might not find e-learning platforms a challenge, university provided resources can help in ease of learning in a course and can influence student engagement.

Students often feel comfortable with online learning owing to its flexible nature when compared with traditional learning. Comfortability of students during online learning also impact their overall experience. A study by Safdar, Rauf, Ullah, & Rehman (2020) has found that comfortableness during online learning leads to better understanding and learning. Students' familiarity and ease allows them to be comfortable while learning through various online platforms (Mohd Basar, Mansor, Jamaludin, & Alias, 2021) and thereby increase satisfaction (Rodriguez, Ooms, & Montañez, 2008).

Another study by Maqableh and Alia (2021), having researched university students revealed that students were highly affected by the pandemic and only a few of them were satisfied with online learning despite being more convenient. Dissatisfaction among them was due to numerous problems. However, if students are satisfied it can increase student engagement in online learning (Baloran & Hernan, 2021). Students' gratification is a significant component to consider when assessing the online learning experience (Alqurashi, 2018), and universities and educational institutions are concerned about it. Muthuprasad, Aiswarya, Aditya and Jha (2021) revealed that pupils preferred online learning since it gave them the flexibility to work as per their own needs and were more satisfied by it.

In addition to resource availability, comfortability and satisfaction, perceived quality of online education is also a key determining variable in assessing online learning experience of students. When pupils perceive online learning to be of good quality they are more satisfied. Pham *et al.* (2019) depicted that the quality of e-learning is a highly important tool to consider as it impacts satisfaction and loyalty of students. Also, Kornpitack and Sawmong (2022) conducted a study and discovered that despite the abrupt switch from conventional educational institutions to online learning, students' expectations of the quality of the new system were comparable to the conventional classroom environment and had an impact on their satisfaction. As a result, a big portion of student online experience is determined by how good they think the online learning system is.

Hence, considering the objectives of this study, it has been hypothesised that

H1: There is significant difference in resilience among the students of higher education with regards to gender in online learning amidst the COVID-19 pandemic.

H2: There is an association between resilience and student online learning experience amidst the COVID-19 pandemic.

H2a: There is an association between resilience and availability of resources amidst the COVID-19 pandemic.

H2b: There is an association between resilience and comfortability amidst the COVID-19 pandemic.

H2c: There is an association between resilience and satisfaction amidst the COVID-19 pandemic.

H2d: There is an association between resilience and perceived quality amidst the COVID-19 pandemic.

## METHODOLOGY

### Population and Sample

All students who are enrolled in graduate and post-graduate programmes and were receiving online education during Covid-19 were taken as population of the study. Data was collected through random sampling. The study sample was collected during May and June of 2021 when second wave of COVID-19 hit India and lockdown was in place. The questionnaire was in English sent through online survey platform (Google Forms). Finally, the participants were 217 university students consisting of graduate as well as post-graduate programmes with age ranging from 18 to 28 years.

### Instruments

The Resilience Assessment Questionnaire (RAQ) is a self-reporting evaluation tool that is open source and is used to quantitatively measure resilience (Mowbray, 2014). The Questionnaire consists of 35 items that range from 1 to 5 on a 5-point Likert scale, with 1 indicating "strongly disagree" and 5 indicating "strongly agree." These are then divided into eight categories:

vision (knowing where you are heading), determination (self-driven), interaction (way you act), relationships (constructing connections), problem solving (capacity to solve problems), organization (highly organized) and self-confidence (being confident in oneself).

To assess the online learning experience of the students six questions on availability of resources, satisfaction, comfortability and perceived quality have been added. These statements have been adapted from validated questionnaires utilised in earlier research (Kohan, et al., 2017; Mohd Basar, Mansor, Jamaludin, & Alias, 2021; Muthuprasad, Aiswarya, Aditya, & Jha, 2021; Pham et al., 2019; Segbenya et al., 2022). These sub-variables have been shown to influence, although not exclusively, the students' resilience levels when experiencing an online learning environment under COVID-19 situation. This scale has also been measured on a 5-point Likert scale. Further the questionnaire was pilot tested with a sample of 30 students of higher education institutions in India before starting data collection via google forms and was found to be valid. Details of the questionnaire is available in Appendix A.

### Procedure

The results of the statistical analysis were done with the help of IBM SPSS Version 26. Statistical techniques such as descriptive analysis, parametric test such as independent samples t-test, Pearson's correlation test were applied for interpretation of data. Descriptive statistics assist us in comprehending the variances in the sample mean. The scores of the questionnaire are added together in each of the category, as well as in total, to assess the total resilience score.

### Participants

Table 1: Socio-demographics characteristics of participants

Sample Characteristics	<i>n</i>	%	<i>M</i>	<i>SD</i>
Gender				
Female	138	63.6		
Male	79	36.4		
Age			23.2436	1.9081
Education				
Under-Graduate	51	23.5		
Post-Graduate	166	76.5		
Stream				
Science	32	14.7		
Commerce	72	33.1		
Arts	37	17.0		
Others	76	35.0		

Note: % =Percentage, *M*= Mean, *SD*= Standard Deviation

Source: Authors

The acquired data was subjected to a reliability analysis. Cronbach's alpha was used to test internal consistency by calculating the average correlation across items. The result for Resilience assessment questionnaire with 35 items came out to be 0.89 with alpha of Vision (0.70), Determination (0.58), Interaction (0.47), Relationships (0.27), Problem-Solving (0.66), Organisations (0.59) and Self-Confidence (0.63) with five items in each. The alpha for scale measuring online learning came out to be 0.885 which depicted the scale to be well adjusted.

The sample included a total of 217 higher education students in India. Despite taking care while selection of sample, the final data appeared to be skewed towards female students. When considering the distribution of sample by gender, it was seen that there were 79 Male (36.4%) and 138 Female (63.6%) students. Female students formed the majority of the sample. When examined by the education level, 51 (23.5%) were pursuing undergraduate degree and 166 (76.5 %) were postgraduate students. As seen in Table 1, the students' age ranged from 18 to 28, with an average age of 23.4 years and a standard deviation of 1.9 years. The breakdown of students based on their stream was as follows: Science students made up 14.7% of the total, while 33.1% studied commerce, 17.0% were pursuing Arts and 35% were studying other streams such as Law, Architecture, Information Technology and so on.

## RESULTS

Table 2 summarizes the descriptive data for the study's constructs. The range of resilience score of the questionnaire has been 35-175. The resilience score among the students has been then divided into three categories i.e., low, medium and high. A score

between 35 and 105 indicates a low level of resilience and the need to pay closer attention to its development. A score of 141-771 indicates exceptionally high levels of resilience and score ranging from 106 to 140 lies in the medium level category. The mean value of the resilience scores of the respondents is 133.53 with minimum of 96 and maximum score of 170. This depicts that average higher education student falls into the medium resilience category i.e., between 106 and 140. The mean value for student online learning experience during COVID-19 ranged from 3.38 to 3.69.

Table 2: Descriptive statistics of resilience scores and student online learning experience

	<i>M</i>	<i>SD</i>	<i>Skewness</i>	<i>Kurtosis</i>
Resilience Scores	133.53	15.28	0.148	-0.159
Availability of Resources	3.63	0.909	-0.359	-0.384
Comfortability	3.38	1.120	-0.050	-0.926
Satisfaction	3.43	1.048	-0.065	-0.743
Perceived Quality	3.69	0.916	-0.400	-0.299

Note: *Min.*=Minimum, *Max.*= Maximum, *M*=mean, *SD*= Standard Deviation

Source: Authors

Table 3: Cross-tabulation of gender and level of resilience among categories

		Low Resilience	Medium Resilience	High Resilience
Overall Resilience Score	Female	5.1% ( <i>n</i> =7)	68.8% ( <i>n</i> =95)	26.1% ( <i>n</i> =36)
	Male	3.8% ( <i>n</i> =3)	44.3% ( <i>n</i> =35)	51.9% ( <i>n</i> =41)
Vision	Female	3.6% ( <i>n</i> =5)	51.4% ( <i>n</i> =71)	44.9% ( <i>n</i> =62)
	Male	6.3% ( <i>n</i> =5)	44.3% ( <i>n</i> =35)	49.4% ( <i>n</i> =39)
Determination	Female	11.6% ( <i>n</i> =16)	68.8% ( <i>n</i> =95)	19.6% ( <i>n</i> =27)
	Male	6.3% ( <i>n</i> =5)	59.5% ( <i>n</i> =47)	34.2% ( <i>n</i> =27)
Interaction	Female	10.1% ( <i>n</i> =14)	63.0% ( <i>n</i> =87)	26.8% ( <i>n</i> =37)
	Male	0.0% ( <i>n</i> =0)	51.9% ( <i>n</i> =41)	48.1% ( <i>n</i> =38)
Relationships	Female	5.8% ( <i>n</i> =8)	67.4% ( <i>n</i> =93)	26.8% ( <i>n</i> =37)
	Male	0.0% ( <i>n</i> =0)	48.1% ( <i>n</i> =38)	51.9% ( <i>n</i> =41)
Problem-Solving	Female	13.0% ( <i>n</i> =18)	52.9% ( <i>n</i> =73)	34.1% ( <i>n</i> =47)
	Male	3.8% ( <i>n</i> =3)	39.2% ( <i>n</i> =31)	57.0% ( <i>n</i> =45)
Organization	Female	43.5% ( <i>n</i> =60)	46.4% ( <i>n</i> =64)	10.1% ( <i>n</i> =14)
	Male	25.3% ( <i>n</i> =20)	46.8% ( <i>n</i> =37)	27.8% ( <i>n</i> =22)
Self-confidence	Female	18.1% ( <i>n</i> =25)	60.1% ( <i>n</i> =83)	21.7% ( <i>n</i> =30)
	Male	10.1% ( <i>n</i> =8)	59.5% ( <i>n</i> =47)	30.4% ( <i>n</i> =24)

Source: Authors

The resilience levels among the eight categories cross-tabulated with gender among the students of higher education during confinement are presented in Table 3. When comparing overall resilience scores of students, female students showed majority in medium resilience whereas, male students made up a majority in high resilience. Taking a glance at the resiliency factors, organization was the only factor in which low resiliency presented a high percentage in both males (23.5%) and females (43.5%). Medium resilience was found to be prevalent in all factors among both genders. Male students, on the other hand, exhibited high resilience in the vision, relationships, and problem-solving categories.



Table 4: Independent T-Test results regarding significant difference in resilience among students and gender

	Gender	<i>n</i>	<i>M</i>	<i>SD</i>	<i>t</i>	<i>df</i>	<i>Sig.</i> (2-tailed)
Resilience Scores	Female	138	130.65	14.72	-3.786	215	0.000
	Male	79	138.55	15.08			

Note: *M*= Mean, *SD*= Standard Deviation

Source: Authors

In Table 4, results of independent t-test related to the significant difference between the resilience scores with regards to the respondents' gender is presented. It also depicts the resilience scores of higher education students in terms of their gender. Both genders show good medium level resilience (Female=130.65 and Male=138.55) as the cumulative average resilience score seen earlier was 133.53. On the basis of this table, alternate hypothesis (H1) is accepted as there is significance difference in resilience scores ( $t[215] = -3.786$ ,  $p < 0.01$ ) based on gender.

Table 5: Correlation Test Results between resilience scores and student experience of online learning scores

Variables	Availability of Resources	Comfortability	Satisfaction	Perceived Quality
Availability of Resources	1			
Comfortability	.728**	1		
Satisfaction	.547**	.503**	1	
Perceived Quality	.997**	.735**	.546**	1
Resilience Scores	.552**	.398**	.445**	.348**

Note: \*\* significant values at 95% confidence interval

Source: Authors

Correlation Test Results between resilience scores and student experience of online learning scores are given above in Table 5. Pearson's correlation among the resilience scores and online learning experience scores of students has been applied. The scores of students' resilience and their overall online learning experience were positively correlated during the pandemic. The correlation of resilience scores with availability of resources ( $r=.552$ ,  $p < 0.01$ ), comfortability ( $r=.398$ ,  $p < 0.01$ ), satisfaction ( $r=.445$ ,  $p < 0.01$ ) and perceived quality ( $r=.348$ ,  $p < 0.01$ ) were all positively and significantly correlated. Therefore, H2 (H2a, H2b, H2c, H2d) are supported.

## DISCUSSIONS

Resilience levels of students of higher education experiencing online learning under COVID-19 conditions has been investigated in this study. Firstly, the descriptive analysis has displayed that among the sample almost half of the respondents have reported a medium level of resilience. This finding of the descriptive analysis agrees with other studies that has also reported moderate degree of resilience (Labrague & De los Santos, 2020; Román-Mata et al., 2020). On the other hand, a study by Sarmiento, Ponce, & Bertolín (2021) has found that college students during the pandemic reported high degree of resilience independent of socio-demographic characteristics. It is also discovered that a large majority of students have had a poor level of resilience in the organization factor, which is one of the eight categories of resilience and refers to one's skill to maintain control even in the face of adversity (Mowbray, 2014). The average scores of males were higher than the average female scores and the cumulative average of the scores. Males depicted a greater degree of resilience than female students. The reason for this may be due to cultural factors that lay more responsibility to males which acquits them with skills that assists them in these categories.

The present study has also found that there exists a significant difference between resilience among students of higher education with regard to gender in online learning amidst the COVID-19 pandemic. In vision, relationships, and problem-solving factors of the resiliency scale, male respondents have reported higher levels of resilience than females. Gender differences in degree of resilience have also been depicted in previous studies (Román-Mata, et al., 2020) whereas some studies have revealed opposing results to this (Bozdog, 2020). The resilience scores were reported to be higher in male students as compared to female students which are in line with earlier research (Park, et al., 2015). However, these results were found to be different from a study done in India by Biswas (2021) where it was reported that female students were more resilient than male students. This might be due to various reasons namely demographic, social and cultural factors.

In this study the authors found that there is an association between resilience and student online learning experience in online learning and this relationship between the four variables which are availability of resources, comfortability, satisfaction and perceived quality. All of them had a positive and significant correlation with resilience scores of students. As studied by various

researchers, resilience increases students' ability to adapt to adversity and is thereby beneficial in times like today in the wake of COVID-19. Since level of resilience in students can influence how they interact with online learning and what kind of experience they have. A good positive experience leads better academic performance and satisfaction of students. A recent study conducted by Ramadhanaa *et al.* (2021) also found a similar correlation between academic resilience and readiness for online learning. This finding also reflects that students' ability to strive in uncertain situations acts as a helpful tool for online learning during the uncertain situations that have been created by the pandemic.

### IMPLICATIONS

With an understanding of resilience in higher education students, educational institutions can provide opportunities to develop, harness and enhance resilience among higher education students, as resilience in students helps motivate and support them during online learning and protects them from negative feelings such as anxiety, stress and depression especially during troubling times. While the impact of COVID-19 has been very challenging for students, the degree of resilience reported in this study conveys important insights for adoption and transition to online learning in case of necessities. In addition, for the purpose of enhancing resilience in higher education students, the factors taken to measure online learning experience, such as availability of resources, comfortability, satisfaction and perceived quality, may be helpful for as all of them were positively correlated with resilience scores found in students. Moreover, since, females have been found to be less resilient than males, there should be a focus on gender focused resilience building and enhancing programs.

### LIMITATIONS AND SUGGESTIONS FOR FUTURE RESEARCH

However, the current study also possesses some limitations. The sample of this study holds clear limits due to its skewness towards female participants. In addition, some factors that can influence students' online learning experience and resilience levels such as the respondents' proximity with someone who might have contacted COVID-19, or whether the respondents have lived alone or with their parents, or their area of residence such as urban or rural, and the like might also influence the results which have not been accounted for in the present study. Resilience is a complex concept, and it is context specific. The questionnaire used has not been validated by other researchers. Hence, future research should be conducted through a cross-sectional sample so that the relationship between resilience levels and online learning experience can be understood at all levels of education and not just at higher education level. Moreover, since students and teachers get more used to online learning this can also affect their resilience which can be further studied. Students who have just enrolled in a course also show different resilience levels as compared to students in later years of their education. This study utilizes correlational analysis and thus causal analysis is not possible. Further studies can be done to remedy this.

### REFERENCES

- Ahmed, Z., & Julius, S. H. (2015). Academic performance, resilience, depression, anxiety and stress among women college students. *Indian Journal of Positive Psychology*, 6(4), 367-370.
- Alqurashi, E. (2018). Predicting student satisfaction and perceived learning within online learning environments. *Distance Education*, 40(1), 133-148. <https://doi.org/10.1080/01587919.2018.1553562>
- Alzahrani, M. G., & O'Toole, J. M. (2017). The impact of internet experience and attitude on student preference for blended learning. *Journal of Curriculum and Teaching*, 6(1), 65. <https://doi.org/10.5430/jct.v6n1p65>
- Appolloni, A., Colasanti, N., Fantauzzi, C., Fiorani, G., & Frondizi, R. (2021). Distance learning as a resilience strategy during covid-19: An analysis of the italian context. *Sustainability*, 13(3), 1388. <https://doi.org/10.3390/su13031388>
- Baloran, E. T., & Hernan, J. T. (2021). Course satisfaction and student engagement in online learning amid COVID-19 pandemic: A structural equation model. *Turkish Online Journal of Distance Education*, 22(4), 1-12. <https://doi.org/10.17718/tojde.1002721>
- Mohd Basar, Z., Mansor, A. N., Jamaludin, K. A., & Alias, B. S. (2021). The effectiveness and challenges of online learning for secondary school students – A case study. *Asian Journal of University Education*, 17(3), 119. <https://doi.org/10.24191/ajue.v17i3.14514>
- Biswas, A. (2021). A Study on resilience among the students at higher education level in West Bengal. *International Journal of Multi Disciplinary Educational Research*, 10(1(4)), 126-129.
- Bozdağ, B. (2020). Examination of psychological resilience levels of high school students. *World Journal of Education*, 10(3), 65. <https://doi.org/10.5430/wje.v10n3p65>
- Brewer, Margo L., van Kessel, G., Sanderson, B., Naumann, F., Lane, M., Reubenson, A., & Carter, A. (2019). Resilience in higher education students: A scoping review. *Higher Education Research & Development*, 38(6), 1105-1120. <https://doi.org/10.1080/07294360.2019.1626810>
- Chow, K. M., Tang, F. W. K., Tang, W. P. Y., & Leung, A. W. Y. (2020). Resilience-building module for undergraduate nursing students: A mixed-methods evaluation. *Nurse Education in Practice*, 49, 102912. <https://doi.org/10.1016/j.nepr.2020.102912>
- Clohesy, N., McKellar, L., & Fleet, J. (2019). Bounce back- bounce forward: Midwifery students experience of resilience.. *Nurse education in practice*, 37, 22-28. <https://doi.org/10.1016/j.nepr.2019.04.011>
- Howard, S., Dryden, J., & Johnson, B. (1999). Childhood Resilience: Review and critique of literature. *Oxford Review of Education*, 25(3), 307-323. <https://doi.org/10.1080/030549899104008>
- Kohan, N., Mirmoghtadaie, Z., Ahmady, S., & Rakhshani, T. (2020). An interesting result of a qualitative research: Academic exhaustion barrier to professionalism in medical students. *Journal of Education and Health Promotion*, 9(1), 212. [https://doi.org/10.4103/jehp.jehp\\_703\\_19](https://doi.org/10.4103/jehp.jehp_703_19)

- Kornpitack, P., & Sawmong, S. (2022). Empirical analysis of factors influencing student satisfaction with online learning systems during the COVID-19 pandemic in Thailand. *Heliyon*, 8(3), e09183. <https://doi.org/10.1016/j.heliyon.2022.e09183>
- Labrague, L. J., & Santos, J. A. A. (2020). COVID-19 anxiety among front-line nurses: Predictive role of organisational support, personal resilience and social support. *Journal of Nursing Management*, 28(7), 1653–1661. <https://doi.org/10.1111/jonm.13121>
- Labrague, L. J., & Ballad, C. A. (2021). Lockdown fatigue among college students during the COVID-19 pandemic: Predictive role of personal resilience, coping behaviors, and health. *Perspectives in Psychiatric Care*, 57(4), 1905–1912. <https://doi.org/10.1111/ppc.12765>
- Lee, J. H., Nam, S. K., Kim, A.-R., Kim, B., Lee, M. Y., & Lee, S. M. (2013). Resilience: A meta-analytic approach. *Journal of Counseling & Development*, 91(3), 269–279. <https://doi.org/10.1002/j.1556-6676.2013.00095.x>
- Lozano-Díaz, A., Fernández-Prados, J. S., Figueredo Canosa, V., & Martínez Martínez, A. M. (2020). Impactos del confinamiento por el COVID-19 entre universitarios: Satisfacción Vital, Resiliencia y Capital Social Online. *International Journal of Sociology of Education*, 9, 79–104. <https://doi.org/10.17583/riise.2020.5925>
- Luthar, S. S., Cicchetti, D., & Becker, B. (2000). The Construct of Resilience: A critical evaluation and guidelines for future work. *Child Development*, 71(3), 543–562. <https://doi.org/10.1111/1467-8624.00164>
- Hussein, E., Daoud, S., Alrabaiah, H., & Badawi, R. (2020). Exploring undergraduate students' attitudes towards emergency online learning during COVID-19: A case from the UAE. *Children and Youth Services Review*, 119, 105699. <https://doi.org/10.1016/j.childyouth.2020.105699>
- Mowbray, D. (2014, April 24). *Strengthening personal resilience*. Retrieved 1 27, 2022, from Management Advisory Service: <http://www.mas.org.uk/uploads/articles/strengthening-personal-resilience.pdf>
- Muthuprasad, T., Aiswarya, S., Aditya, K. S., & Jha, G. K. (2021). Students' perception and preference for online education in India during COVID -19 pandemic. *Social Sciences & Humanities Open*, 3(1), 100101. <https://doi.org/10.1016/j.ssaho.2020.100101>
- Naidu, S. (2021). Building resilience in education systems post-COVID-19. *Distance Education*, 42(1), 1–4. <https://doi.org/10.1080/01587919.2021.1885092>
- Oducado, R. M., Parreño-Lachica, G., & Rabacal, J. (2021). Personal resilience and its influence on COVID-19 stress, anxiety and fear among graduate students in the Philippines. *IJERI: International Journal of Educational Research and Innovation*, 15, 431–443. <https://doi.org/10.46661/ijeri.5484>
- Park, K. H., Kim, D., Kim, S. K., Yi, Y. H., Jeong, J. H., Chae, J., Hwang, J., & Roh, H. (2015). The relationships between empathy, stress and social support among medical students. *International Journal of Medical Education*, 6, 103–108. <https://doi.org/10.5116/ijme.55e6.0d44>
- Pham, L., Limbu, Y. B., Bui, T. K., Nguyen, H. T., & Pham, H. T. (2019). Does e-learning service quality influence e-learning student satisfaction and loyalty? Evidence from Vietnam. *International Journal of Educational Technology in Higher Education*, 16(1). <https://doi.org/10.1186/s41239-019-0136-3>
- Quintiliani, L., Sisto, A., Vicinanza, F., Curcio, G., & Tambone, V. (2021). Resilience and psychological impact on Italian university students during COVID-19 pandemic. Distance learning and health. *Psychology, Health & Medicine*, 27(1), 69–80. <https://doi.org/10.1080/13548506.2021.1891266>
- Rahana, S., Sam, J., & Udhayakumar, P. (2021). Depression, anxiety, stress, and resilience among the primary survivors of natural disaster: A study with special reference to Kerala Flood. *Indian Journal of Social Psychiatry*, 37(4), 388. [https://doi.org/10.4103/ijsp.ijsp\\_238\\_20](https://doi.org/10.4103/ijsp.ijsp_238_20)
- Ramadhan, M. R., Putra, A., Pramonojati, T. A., Haqq, R., Dirgantara, P., Ismail, O. A., & Wijakson, D. S. (2021). Learning Readiness as a Predictor of Academic Resilience in Online Learning during School from Home. *Library Philosophy and Practice*, 1-14.
- Reyes, A. T., Andrusyszyn, M.-A., Iwasiw, C., Forchuk, C., & Babenko-Mould, Y. (2015). Resilience in nursing education: An integrative review. *Journal of Nursing Education*, 54(8), 438–444. <https://doi.org/10.3928/01484834-20150717-03>
- Rodríguez, M. C., Ooms, A., & Montañez, M. (2008). Students' perceptions of online-learning quality given comfort, motivation, satisfaction, and experience. *Journal of interactive online learning*, 7(2), 105-125.
- Rodríguez-Hidalgo, A. J., Pantaleón, Y., Dios, I., & Falla, D. (2020). Fear of COVID-19, stress, and anxiety in university undergraduate students: A predictive model for depression. *Frontiers in Psychology*, 11. <https://doi.org/10.3389/fpsyg.2020.591797>
- Román-Mata, S. S., Zurita-Ortega, F., Puertas-Molero, P., Badicu, G., & González-Valero, G. (2020). A predictive study of resilience and its relationship with academic and work dimensions during the COVID-19 pandemic. *Journal of Clinical Medicine*, 9(10), 3258. <https://doi.org/10.3390/jcm9103258>
- Safdar, G., Rauf, A., Ullah, R., & Rehman, A. U. (2020). Exploring factors leading to quality online learning in the era of covid-19: A correlation model study. *Universal Journal of Educational Research*, 8(12A), 7324–7329. <https://doi.org/10.13189/ujer.2020.082515>
- Segbenya, M., Bervell, B., Minadzi, V. M., & Somuah, B. A. (2022). Modelling the perspectives of distance education students towards online learning during COVID-19 pandemic. *Smart Learning Environments*, 9(1). <https://doi.org/10.1186/s40561-022-00193-y>
- Serrano Sarmiento, Á., Sanz Ponce, R., & González Bertolín, A. (2021). Resilience and COVID-19. An analysis in university students during confinement. *Education Sciences*, 11(9), 533. <https://doi.org/10.3390/educsci11090533>
- UNESCO. (2020). *UNESCO's support: Educational response to COVID-19*. Retrieved 1 27, 2022, from <https://en.unesco.org/covid19/educationresponse/support>

- Waxman, H. C., Gray, J. P., & Padron, Y. N. (2003). Review of Research on Educational Resilience: Research Report. *Washington, DC: Institute of Education Sciences.*
- Ye, Z., Yang, X., Zeng, C., Wang, Y., Shen, Z., Li, X., & Lin, D. (2020). Resilience, social support, and coping as mediators between covid-19-related stressful experiences and acute stress disorder among college students in china. *Applied Psychology: Health and Well-Being*, 12(4), 1074–1094. <https://doi.org/10.1111/aphw.12211>
- Zhou, J., & Zhang, Q. (2021). A survey study on U.S. college students' learning experience in COVID-19. *Education Sciences*, 11(5), 248. <https://doi.org/10.3390/educsci11050248>

#### APPENDIX A: Questionnaire for Online Learning Experience of Students

Variable	Item code	Items	Reference
Availability of Resources	AR1	My neighbourhood has reliable, good internet connectivity.	Segbenya et al., (2022)
	AR2	On my device, internet access is less expensive.	
Comfortability	C1	I feel comfortable while attending online classes.	(Mohd Basar et al., 2021)
Satisfaction	S1	Overall, I am satisfied with the quality of online classes.	Alqurashi, (2019)
Perceived quality	PQ1	Online classroom learning in my school is good quality.	Pham et al., (2019)
	PQ2	Online classroom learning is appropriate for my subjects of study.	

Source: Authors

## Precision Finance: Capital Structure Theories Approach Reality

Peter Brusov<sup>1,\*</sup>  
Tatiana Filatova<sup>2</sup>  
Veniamin Kulik<sup>3</sup>  
She-I Chang<sup>4</sup>  
George Lin<sup>5</sup>  
Li-Min Chang<sup>6</sup>

\*Corresponding author

<sup>1</sup> Department of Mathematics, Financial University under the Government of Russian Federation, Moscow, Russia, pnb1983@yahoo.com

<sup>2</sup> Department of financial and investment management, Financial University under the Government of Russian Federation, Moscow, Russia, tvfilatova@fa.ru

<sup>3</sup> Faculty of Information Technology and big data analysis, Financial University under the Government of Russian Federation, Moscow, Russia, venya.kulik@mail.ru

<sup>4</sup> College of Management, National Chung Cheng University, Taiwan, actsic@ccu.edu.tw

<sup>5</sup> College of Management, National Chung Cheng University, Taiwan, actycl@ccu.edu.tw

<sup>6</sup> College of Management, National Chung Cheng University, Taiwan, changclm@gmail.com

### ABSTRACT

Bringing existing financial models closer to real practice is the most important challenge in precision finance. Over the past couple of years, the two main theories of the capital structure (Brusov–Filatova–Orehova (BFO) and Modigliani–Miller (MM)) have been adapted to the established financial practice of the functioning of companies, taking into account the real conditions of their work. They are generalized to the case of variable income, to paying income tax with arbitrary frequency, to the advance payments of income tax etc. Taking these effects into account significantly changed the results of both theories and brought both theories closer to reality.

*Keywords:* Precision finance, capital structure, Generalized Modigliani–Miller (MM) theory, Generalized Brusov–Filatova–Orehova (BFO) theory, actual operating conditions of the company

### INTRODUCTION

One of the most important challenges in precision finance is to bring existing financial models closer to real–world practice. The modern theory of the cost of capital and capital structure – the Brusov–Filatova–Orehova (BFO) theory (Brusov et al. 2018, 2021, 2022, 2023) and its perpetual limit – the Modigliani–Miller theory (Modigliani and Miller 1958, 1963, 1966) describe the case of constant income and payment of income tax at the end of the year. But in practice, companies may make these payments upfront, and the income may be variable. Over the past couple of years, the two main theories of the capital structure (Brusov–Filatova–Orehova (BFO) and Modigliani–Miller (MM)) have been adapted by the authors to the established financial practice of the functioning of companies, taking into account the real conditions of their work. They are generalized to the case of variable income (this is extremely important), as well as to the case of paying income tax with arbitrary frequency, to the case of advance payments of income tax and for the combinations of these effects. Account of these effects has changed the results of both theories significantly and made the Modigliani–Miller theory (which is perpetual limit of Brusov–Filatova–Orehova) closer to Brusov–Filatova–Orehova one, although they will never intersect, since the MM theory does not have a time factor, and the BFO describes companies of arbitrary age.

In case of variable income the role of discount rate for leverage company passes from the weighted average cost of capital, WACC, to  $WACC - g$  (where  $g$  is growing rate), for a financially independent company from  $k_0$  to  $k_0 - g$ . The real discount rates  $WACC - g$  and  $k_0 - g$  decrease with  $g$ , while WACC grows with  $g$ . This decrease leads to an increase in company value with  $g$ .

In case of payments of tax on profit with arbitrary frequency we derived modified BFO formulas and show that: (1) All BFO formulas change; (2) all main financial parameters of the company, such as company value,  $V$ , equity cost,  $k_e$ , and the weighted average cost of capital, WACC, depend on the tax on profit payments frequency. The increase of the frequency of payments of income tax leads to a decrease in the cost of attracting capital, WACC, and to increase in the capitalization of the company,  $V$ . At a certain age  $n$  of the company and at certain frequency of tax on profit payments  $p$ , a qualitatively new anomalous effect takes place: the equity cost,  $k_e(L)$ , decreases with an increase in the level of leverage  $L$ . This radically changes the company's dividend policy, since the economically justified amount of the dividends is equal to the cost of equity. For both parties—for the company and for the tax regulator more frequent payments of tax on profit are beneficial: for the company, because this increases the company capitalization, and for the tax regulator, because earlier payments are beneficial for it due to the time value of money.

The influence of variable incomes, the frequency of income tax payment, advance income tax payments on all major financial indicators (WACC, company value,  $V$ , equity cost,  $k_e$  etc) and their dependence on debt financing was studied and it was shown that this influence is significant and quite important.

**BASIC THEORIES OF CAPITAL STRUCTURE: A HISTORICAL POINT OF VIEW**

From a historical point of view, **five stages** in the development of the capital structure theory can be distinguished: **First** (before 1958) – the traditional approach, based on practical experience and existed before the appearance of the first quantitative theory by Modigliani and Miller (**the second stage**) (Modigliani and Miller 1958, 1963, 1966). **The third stage** (1964– 2008) is the numerous attempts of scientists to modify the Modigliani – Miller theory. **The fourth stage** (2008–2019) is the appearance of Brusov–Filatova–Orekhova (BFO) theory, which removed the main restriction of the Modigliani – Miller (MM) theory associated with the infinite life–time of the company (Brusov, Filatova 2023). And, finally, **the fifth stage** (2019 up to now), which began a couple years ago and is associated with the adaptation of the two main theories of the capital structure (Brusov–Filatova–Orekhova and Modigliani–Miller) to the established financial practice of the company's functioning by taking into account the real conditions of their work (Brusov et al. 2021, 2022,2023).

One of the most important assumptions of the Modigliani – Miller theory is that all financial flows and all companies are perpetuity. This limitation was lift out by Brusov–Filatova–Orekhova in 2008 (Filatova et al 2008), who have created BFO (Brusov–Filatova–Orekhova) theory – modern theory of capital cost and capital structure for companies of arbitrary age (BFO–1 theory) and for companies of arbitrary life time (BFO–2 theory) (Brusov et al 2018). **Fig.1** shows the historical development of the theory of capital structure from the empirical traditional approach to the general theory of capital structure, BFO, through the perpetuity Modigliani–Miller theory.

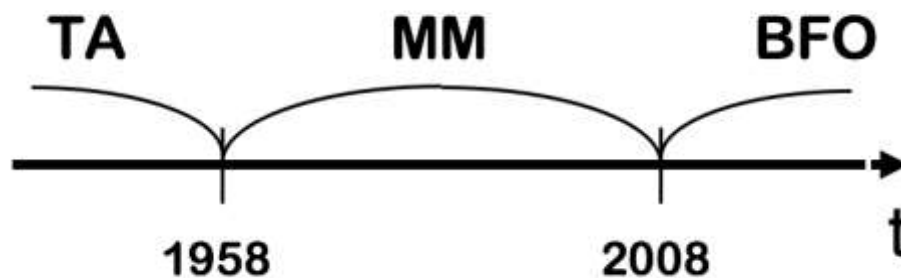

Figure. 1: The historical development of the theory of capital structure from the empirical traditional approach (TA) to the general theory of capital structure, BFO (Brusov–Filatova–Orekhova), through the perpetuity Modigliani–Miller theory.

One year companies were studied by Steve Myers in 2001, who showed that the weighted average cost of capital WACC is greater in this case than in the perpetual Modigliani–Miller case, and the value of company  $V$  is therefore less. Only two results for capital structure of the company were known up to 2008, when BFO theory has appeared: Modigliani–Miller for perpetuity companies and Myers for one–year company (see **Fig. 2**). The created BFO theory filled the entire interval between  $t=1$  and  $t=\infty$ . This expands capital structure theory for the companies of arbitrary ages and/or arbitrary life–time. Many new meaningful effects have been discovered in the BFO theory.



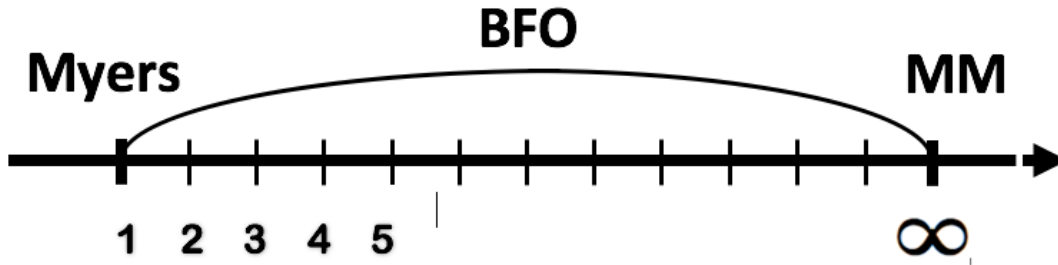

Figure 2: Only two results for capital structure of the company were known before BFO theory: Modigliani–Miller (MM) for perpetuity companies and Myers for one–year company, while the created BFO theory filled the entire interval between  $n=1$  and  $n = \infty$ .

**The Empirical (Traditional) Approach**

In the traditional approach, based on practical experience and existing before the advent of the first quantitative theory of Modigliani and Miller, the weighted average cost of capital WACC and the associated capitalization of the company,  $V = CF / WACC$ , depend on the capital structure, the level of debt load, L. The cost of debt is always lower than the cost of equity, because the former has less risk due to the fact that the claims of creditors are satisfied before the claims of shareholders in the event of bankruptcy. As a result, an increase in the share of cheaper borrowed capital in the total capital structure to the limit that does not cause a violation of financial stability and an increase in the risk of bankruptcy leads to a decrease in the weighted average cost of capital WACC. The return required by investors (equal to the cost of equity) is growing; however, its growth did not offset the benefits of using cheaper borrowed capital. Therefore, the traditional approach welcomes the increase in leverage  $L = D / S$  and the associated increase in the value of the company  $V = CF / WACC$ . The empirical traditional approach existed until the appearance of the first quantitative theory by Modigliani and Miller (1958).

Within the based on existing practical experience traditional approach the competition between the advantages of debt financing at a low leverage level and its disadvantages at a high leverage level forms the optimal capital structure, defined as the leverage level, at which WACC is minimal and company value, V, is maximum.

**BENEFITS OF ADVANCE PAYMENTS OF TAX ON PROFIT: CONSIDERATION WITHIN BRUSOV–FILATOVA–OREKHOVA (BFO) THEORY**

The modern theory of the cost of capital and capital structure – the Brusov–Filatova–Orekhova (BFO) theory and its perpetual limit – the Modigliani–Miller theory describe the case of constant income and payment of income tax at the end of the year. But in practice, companies may make these payments upfront, and the income may be variable. Recently we have modified the Modigliani–Miller theory for the case of advanced payments of income tax and have shown that obtained results are quite different from ones in “classical” Modigliani–Miller theory. In current paper for the first time we modify the Brusov–Filatova–Orekhova (BFO) theory for the case of advanced payments of income tax and show that the impact of the transition to advance payments is much more significant than in the case of an perpetuity limit (the MM theory) and even leads to a qualitatively new effect in the dependence of equity cost on leverage. An important conclusion made in this paper is that the tax shield is very important and the way it is formed (payments at the end of the year or in advance) leads to very important consequences, changing, in particular, the company’s dividend policy. The final Brusov–Filatova–Orekhova equation for WACC for the case of advanced payments of income tax

$$\frac{(1 - (1 + WACC)^{-n})}{WACC} = \frac{(1 - (1 + k_0)^{-n})}{k_0(1 - w_d t \cdot (1 - (1 + k_d)^{-n})) \cdot (1 + k_d)} \tag{1}$$

This formula differs from the classical Brusov–Filatova–Orekhova equation by the factor  $(1 + k_d)$  in the left denominator

$$\frac{(1 - (1 + WACC)^{-n})}{WACC} = \frac{(1 - (1 + k_0)^{-n})}{k_0(1 - w_d t \cdot (1 - (1 + k_d)^{-n}))} \tag{2}$$

**Results**



Here the dependence of the weighted average cost of capital, WACC, capital value, V, equity cost,  $k_e$ , on leverage level L for three-year and six-year companies, using Microsoft Excel is being studied. We consider two types of payments of income tax: (1) at the end of the year and (2) in advance. As we mentioned above, for WACC we use formulas (12) and (13), for capital value, V, we use formulas (6) and (7) and for equity cost,  $k_e$ , we use formula (15).

We use the following parameters:  $k_0=0.2$ ;  $k_d=0.18$ ;  $t=0.2$ ;  $n=3$ ; 6;  $CF=100$ .

**Dependence of the Weighted Average Cost of Capital, WACC, Capital Value, V, Equity Cost,  $k_e$ , on Leverage Level L for Three-year Company**

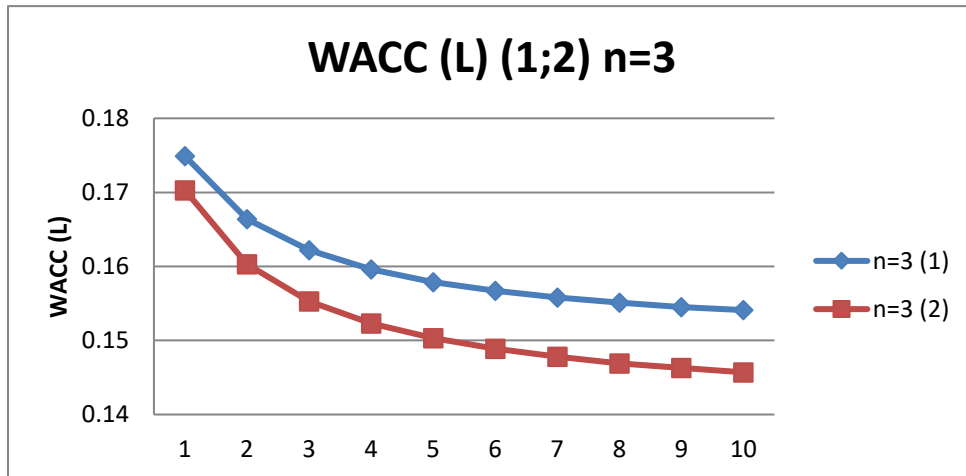

Figure 3: Dependence of the weighted average cost of capital, WACC, on leverage level L in the cases of payments of tax on profit at the end of the year (1) and in the beginning of the year (2) for three-year company

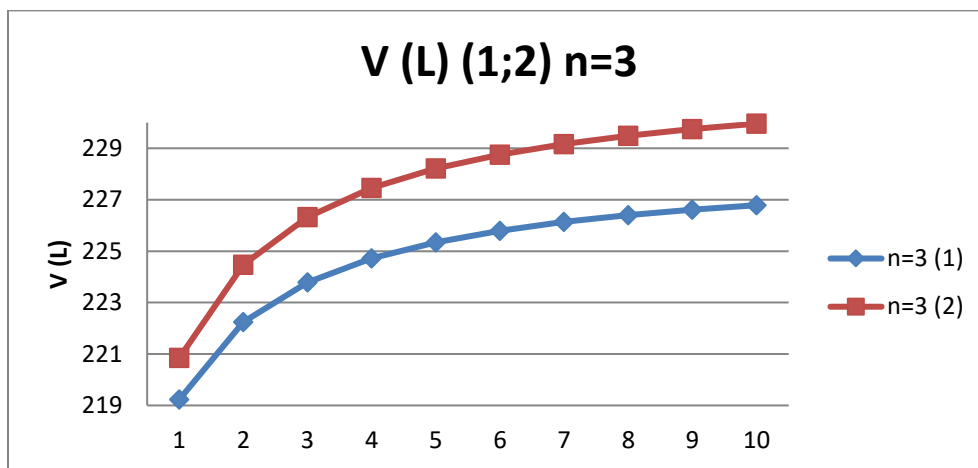

Figure 4: Dependence of the company value, V, on leverage level L in the cases of payments of tax on profit at the end of the year (1) and in the beginning of the year (2) for three-year company

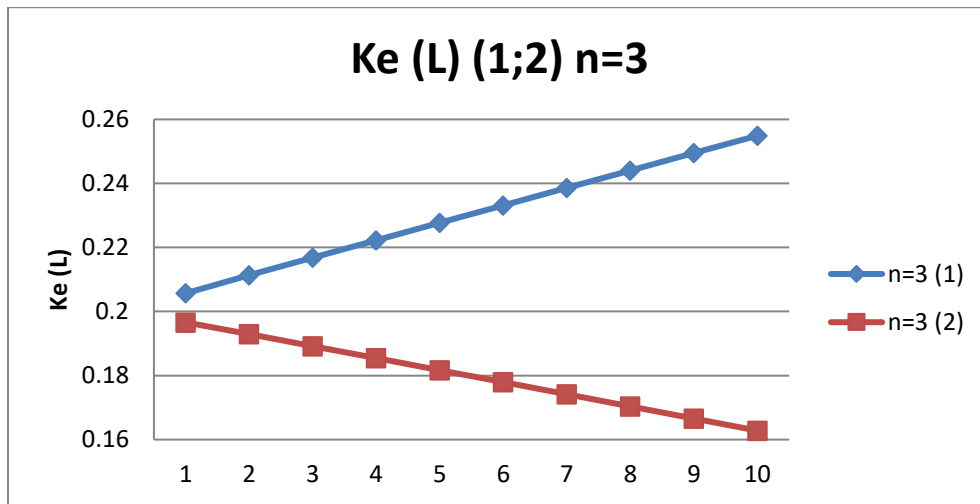

Figure 5: Dependence of the equity cost,  $k_e$  on leverage level  $L$  in the cases of payments of tax on profit at the end of the year (1) and in the beginning of the year (2) for three-year company

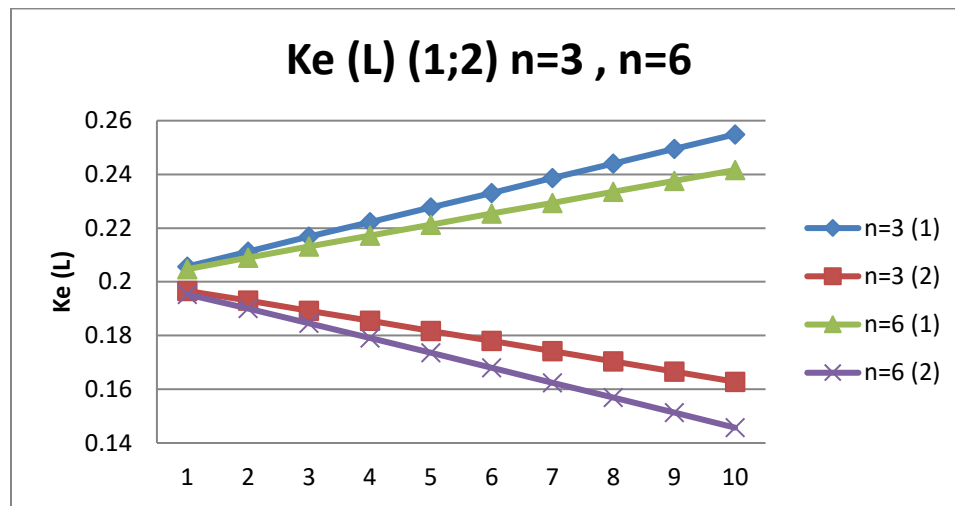

Figure 6: Dependence of the equity cost,  $k_e$  on leverage level  $L$  in the cases of payments of tax on profit at the end of the year (1) and in the beginning of the year (2) for three-year and six-year companies

## Discussion

We derive BFO formulas for WACC,  $V$ ,  $k_e$  for the case of advanced payments of income tax. Making the calculations using these formulas within Microsoft Excel we get the following results (see Figures 3–6).

1. WACC ( $L$ ) decreases with  $L$  in both cases. This means that debt financing is important and should be used by company – it leads to decrease of attracting capital cost with  $L$ .
2. WACC turns out to be lower in the case of advanced payments of income tax, this tells about importance of the use of advanced payments of income tax for companies.
3. WACC decreases with company age: this is one of the important results of classical BFO theory.
4. Company value,  $V$ , increases with  $L$  in both cases, this follows from the decrease of attracting capital cost with  $L$ .
5. Company value,  $V$ , turns out to be bigger in the case of advanced payments of income tax: this tells about importance of the use of advanced payments of income tax for companies.
6. Company value,  $V$ , increases with company age
7. Equity cost  $k_e$  decreases with company age in both cases: this is one of the important results of classical BFO theory.
8. Equity cost  $k_e$  increases with leverage level  $L$  in the case of payments of income tax at the end of the year.

9. Equity cost  $k_e$  decreases with leverage level  $L$  in the case of advanced payments of income tax. This means the appearance of a qualitatively new effect that can greatly change the company's dividend policy, because the economically justified amount of dividends is equal to the equity cost.

**Summary and Conclusions**

Advance income tax payments are beneficial to both parties: to companies, because they lead to decrease of cost of attracting capital and increase of company values; to regulator, because earlier replenishment of the budget ensures an increase in the stability of budget revenues.

An important conclusion made in this paper is that the tax shield is very important and the way it is formed (payments at the end of the year or in advance) leads to very important consequences, changing, in particular, the company's dividend policy. If with payments at the end of the year, the amount of dividends should increase with the increase in the use of debt financing, with advance payments of income tax the amount of dividends should decrease with the increase in the use of debt financing: this is a pioneering result that radically changes the company's dividend policy.

**THE GENERALIZATION OF THE BRUSOV–FILATOVA–OREKHOVA THEORY FOR THE CASE OF PAYMENTS OF TAX ON PROFIT WITH ARBITRARY FREQUENCY**

Both main theories of capital cost and capital structure – the Brusov–Filatova–Orekhova (BFO) theory and its perpetuity limit – the Modigliani–Miller theory– consider the payments of tax on profit once per year, while in real economy these payments are made more frequently (semi–annual, quarterly, monthly etc.). Recently the Modigliani–Miller theory has been generalized by us for the case of tax on profit payments with an arbitrary frequency. Here for the first time we generalized the Brusov–Filatova–Orekhova (BFO) theory for this case. The main purpose of the paper is bring the BFO theory closer to economic practice, taking into account one of the features of the real functioning of companies – the frequent payments of tax on profit. We derive modified BFO formulas and show that: (1) all BFO formulas change; (2) all main financial parameters of the company, such as company value,  $V$ , the weighted average cost of capital, WACC, and equity cost,  $k_e$ , depend on the frequency of tax on profit payments. It turns out that the increase of the number of payments of tax of profit per year leads to decrease of the cost of attracting capital, WACC and increase of the company value,  $V$ . At a certain age  $n$  of the company and at certain frequency of tax on profit payments  $p$ , a **qualitatively new anomalous effect** takes place: the equity cost,  $k_e(L)$ , decreases with an increase of the level of leverage  $L$ . This radically changes the company's dividend policy, since the economically justified amount of the dividends is equal to the cost of equity. More frequent payments of income tax are beneficial for both parties – for the company and for the tax regulator: for the company, this leads to an increase in the value of the company, and for the tax regulator, earlier payments are beneficial due to the time value of money.

We have derived the modified formula BFO for weighted average cost of capital (WACC) for company of age  $n$  years for the case of  $p$  payments of tax on profit per year (payments at the end of periods)

$$\frac{1 - (1 + WACC)^{-n}}{WACC} = \frac{(1 - (1 + k_0)^{-n})}{k_0 \left( 1 - \frac{k_d w_d t (1 - (1 + k_d)^{-n})}{p \left( (1 + k_d)^{1/p} - 1 \right)} \right)} \tag{3}$$

For the the Modigliani–Miller limit one has

$$WACC = k_0 \left( 1 - \frac{k_d w_d t}{p \left( (1 + k_d)^{1/p} - 1 \right)} \right) \tag{4}$$

At  $p=1$  we get **classical** BFO formula

$$\frac{1 - (1 + WACC)^{-n}}{WACC} = \frac{1 - (1 + k_0)^{-n}}{k_0 \cdot (1 - w_d t [1 - (1 + k_d)^{-n}])} \tag{5}$$

For the the Modigliani–Miller limit one has

$$WACC = k_0(1 - w_d t) \tag{6}$$

**Formulas for Capital Value, V, and Equity Cost, Ke**

Below we investigate the dependence of the weighted average cost of capital, WACC, capital value, V, equity cost, ke, on leverage level L at different frequency of payment of tax on profit p for three-year and six-year companies, using Microsoft Excel. For WACC we will use formula (3) and for capital value, V, and equity cost, ke, we will use formulas (7) and (8) respectively (see below).

Company of age n capitalization could be calculated by the following formula

$$V = \frac{CF \cdot (1 - (1 + WACC)^{-n})}{WACC} \tag{7}$$

ke should be found from the equation

$$WACC = k_e w_e + k_d w_d (1 - t)$$

$$k_e = \frac{WACC}{w_e} - \frac{k_d(1-t)w_d}{w_e} = WACC(1 + L) - Lk_d(1-t) \tag{8}$$

where one should substitute WACC from the formula (3).

**Results**

In this section we study the dependence of the weighted average cost of capital, WACC, capital value, V, equity cost, ke, on leverage level L at different frequency of payment of tax on profit p for three-year and six-year companies, using Microsoft Excel. As we mentioned above, for WACC we use formula (3) and for capital value, V, and equity cost, ke, we use formulas (7) and (8) respectively.

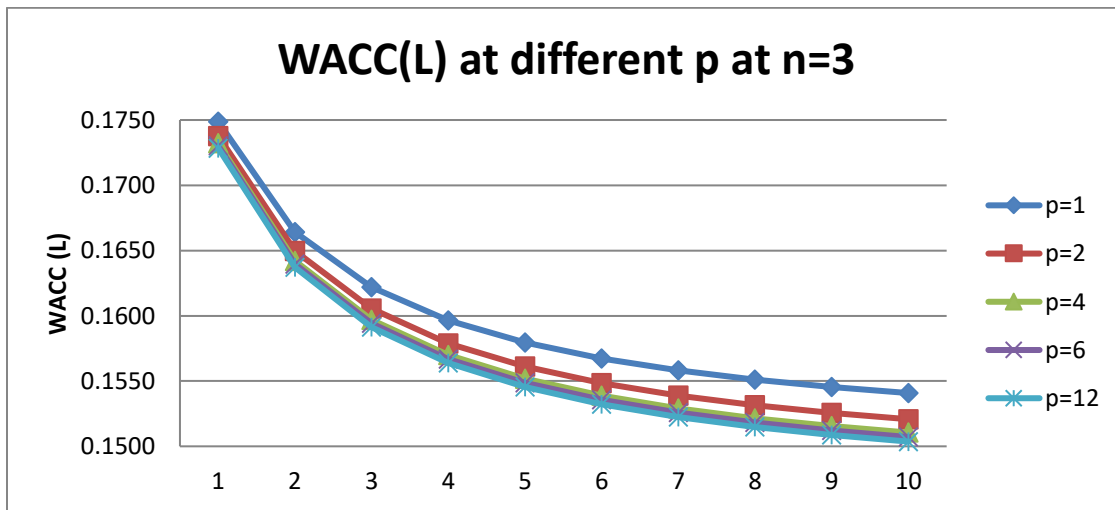

Figure 7: Dependence of the weighted average cost of capital, WACC, on leverage level L at different frequency of payments of tax on profit p for three-year company

The weighted average cost of capital, WACC, decreases with leverage level L at any frequency of payments of tax on profit p. The difference between the WACC (L) curves is maximum when moving from annual (p=1) to semi-annual (p=2) income tax payments and decreases when moving from semi-annual (p=2) to quarterly (p=4) payments and from quarterly (p=4) to monthly (p=12) payments.

**Dependence of The Company Value, on Leverage Level L at Different Frequency of Payment of Tax on Profit p for Three-year Company**

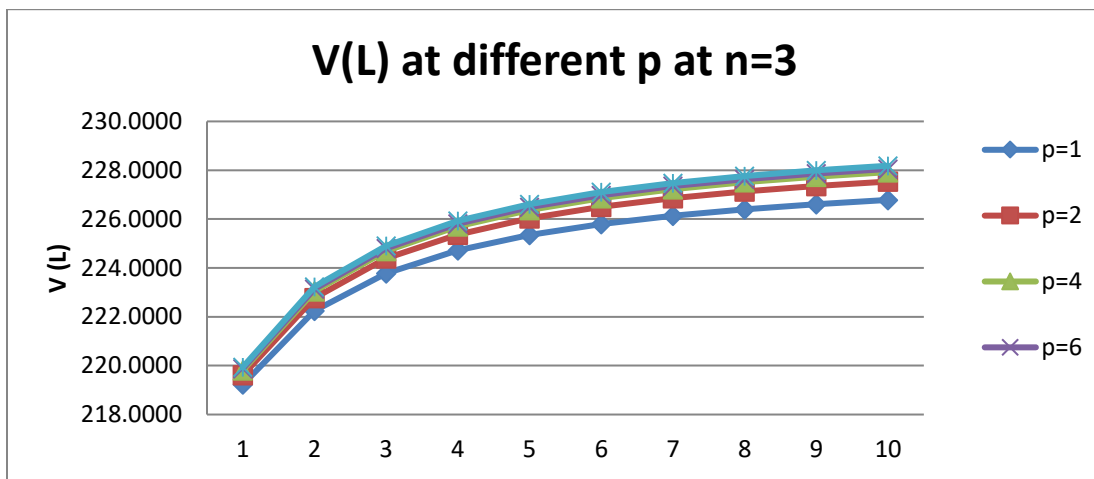

Figure 8: Dependence of the company value,  $V$ , on leverage level  $L$  at different frequency of payments of tax on profit  $p$  for three-year company

The value of company  $V$  increases with the frequency  $p$ . The largest increase occurs when moving from annual ( $p=1$ ) to semi-annual ( $p=2$ ) income tax payments and decreases when moving from semi-annual ( $p=2$ ) to quarterly ( $p=4$ ) payments and from quarterly ( $p=4$ ) to monthly ( $p=12$ ) payments.

**Dependence of The Equity Cost,  $k_e$ , on Leverage Level  $L$  at Different Frequency of Payment of Tax on Profit  $p$  for Three-year Company**

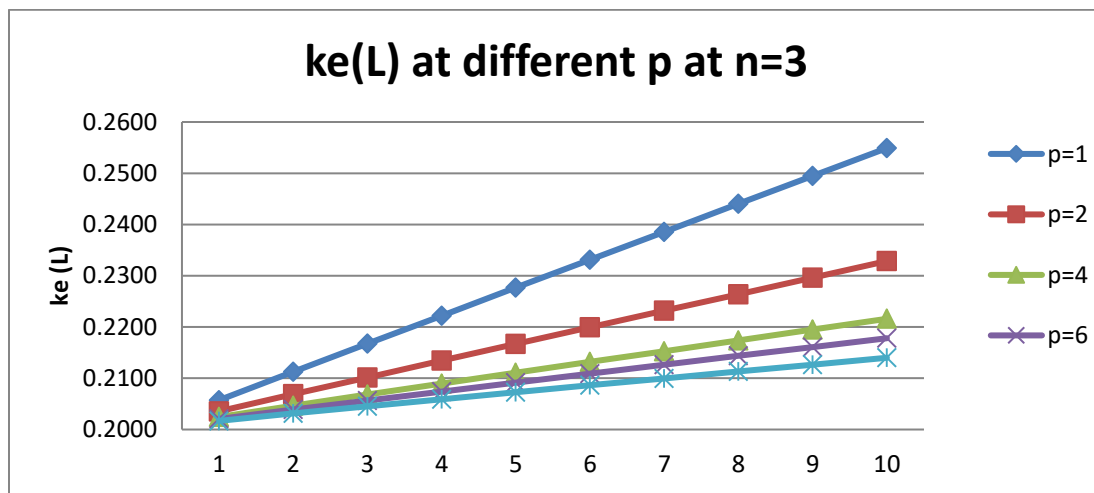

Figure 9: Dependence of the equity cost,  $k_e$ , on leverage level  $L$  at different frequency of payments of tax on profit  $p$  for three-year company

The cost of equity  $k_e$  increases linearly with the level of leverage  $L$ . The slope of the curve  $k_e(L)$  depends on the frequency of paying income tax: it decreases with increasing  $p$ , most rapidly when moving from annual ( $p=1$ ) to semi-annual ( $p=2$ ) payments of income tax and slower in the transition from semi-annual ( $p=2$ ) to quarterly ( $p=4$ ) payments and from quarterly ( $p=4$ ) to monthly ( $p=12$ ) payments.

**GENERALIZATION OF THE MODIGLIANI – MILLER AND BRUSOV–FILATOVA–OREKHOVA THEORY FOR THE CASE OF VARIABLE PROFIT**

The main theory of capital cost and capital structure Brusov–Filatova–Orekhova (BFO) theory and its perpetuity limit – theory by Nobel Prize winners Modigliani and Miller consider the case of constant profit, while in practice profit of the company is, of cause, variable. Recently we have generalized the Modigliani – Miller theory for the case of variable profit, and here for the first time we have generalized the Brusov–Filatova–Orekhova theory for the case of variable profit.

This generalization significantly expands the applicability of this modern capital structure theory, which is valid for companies of arbitrary age, in practice, in particular, in corporate finance, in investments, in business valuation, in banking, in ratings, etc.

We derive the generalized Brusov–Filatova–Orekhova formula for WACC and, using this formula in MS Excel, we show that the role of the discount rate shifts from the weighted average cost of capital WACC to WACC–g (where g is the growth rate) for financially dependent companies and k0–g (for financially independent companies). While WACC increases with g, the real discount rates WACC–g and k0–g decrease with g and, accordingly, the value of the company increases with g. For the cost of equity ke, the slope of the curve ke (L) increases with g. Since the economically justified amount of dividends is equal to the cost of equity, this should change the company's dividend policy. It turns out that at the rate  $g < g^*$  the slope of the curve ke(L) becomes negative, which can significantly change the principles of the company's dividend policy. This means the discovery of a qualitatively new effect in corporate finance.

We have derived the BFO equation for the case of variable profit of the company

$$\frac{1 - \left(\frac{1+g}{1+WACC}\right)^n}{WACC - g} = \frac{1 - \left(\frac{1+g}{1+k_0}\right)^n}{(k_0 - g) \cdot \left(1 - w_d t \left[1 - (1+k_d)^{-n}\right]\right)} \tag{9}$$

This is the main theoretical result of paper Brusov et al. 2022.

In perpetuity (Modigliani – Miller) limit ( $n \rightarrow \infty$ ) we get the following equation for WACC in the Modigliani–Miller theory in the case of variable profit

$$WACC - g = (k_0 - g) \cdot (1 - w_d T) \tag{10}$$

$$WACC = (k_0 - g) \cdot (1 - w_d T) + g \tag{11}$$

Let us consider first the case of Generalized Modigliani–Miller theory (GMM theory).

**The Case of Generalized Modigliani–Miller Theory (GMM theory).**

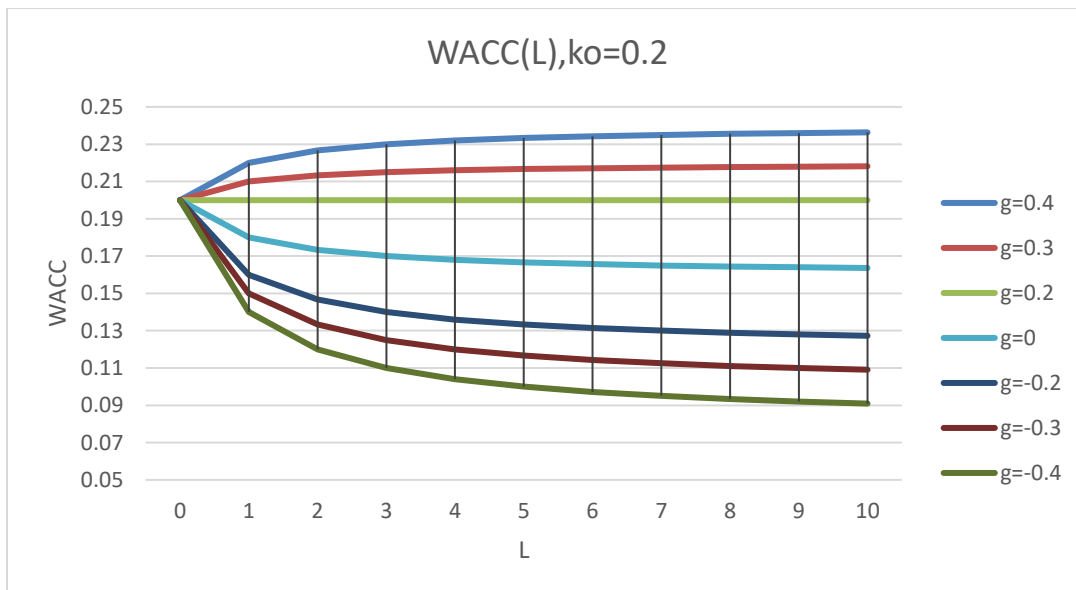

**Figure 10:** Dependence of WACC on leverage level  $L$  in Generalized Modigliani–Miller theory (GMM theory) at  $k_0=0.2$  and  $g = 0; \pm 0.2; \pm 0.3; \pm 0.4$

From Fig.10. it is seen that all curves  $WACC(L)$  for different  $g$  start from one point  $k_0$ , in this case from point  $(0; 0.2)$ . They decrease with leverage level  $L$  at  $g < 0.2$  (at  $g = 0; \pm 0.2; -0.3; -0.4$ ) and increase at  $g > 0.2$  (at  $g = 0.3; 0.4$ ). The curves  $WACC(L)$  increase with growth rate,  $g$ . Note, that cut-off value of  $g$ , which separate increasing curves  $WACC(L)$  from decreasing ones is equal to  $k_0=0.2$ , and  $WACC$  is constant at  $g=k_0$  and equal to  $k_0$ . Below we check this observation at different value of  $k_0$  ( $k_0=0.3$ ).

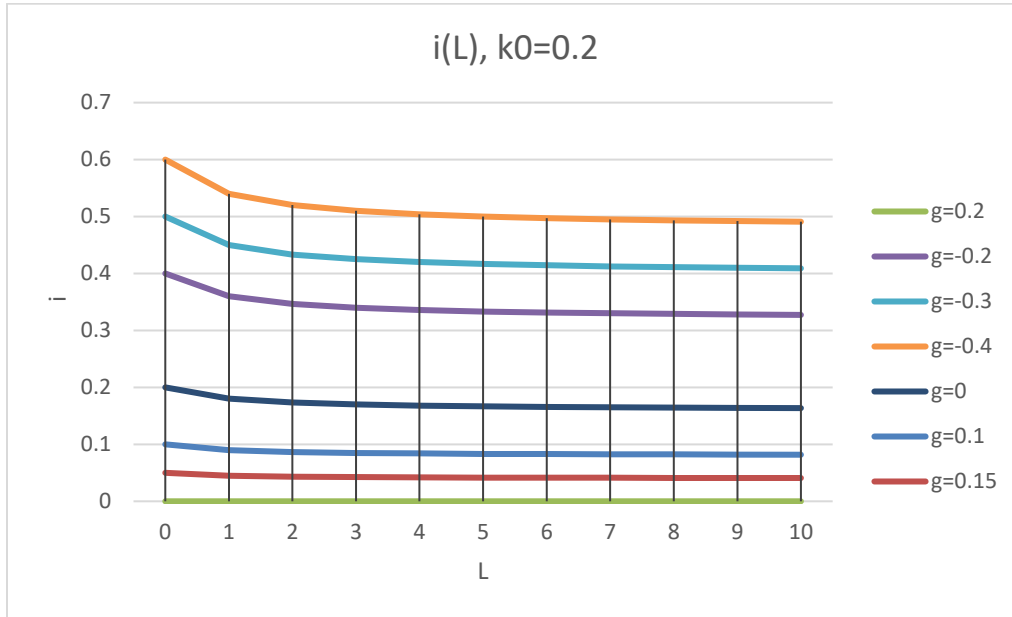

Figure 11: Dependence of discount rate  $i$  on leverage level  $L$  in Generalized Modigliani–Miller theory (GMM theory) at  $k_0=0.2$  and  $g = 0; 0.1; 0.15; \pm 0.2; -0.3; -0.4$

From Fig. 11 it is seen that discount rate  $i$  decreases with leverage level  $L$  at growth values  $g < k_0$  (at  $g = 0; 0.1; 0.15; \pm 0.2; -0.3; -0.4$ ). Discount rate  $i$  in opposite to WACC decreases with  $g$ : this provides the increase of company value  $V$  with  $g$ .

At  $g > k_0$  discount rate  $i$  increases with  $L$ , being negative (it is not shown at Fig.11).

**Dependence of discount rate  $i$  on leverage level  $L$  in Generalized Modigliani–Miller theory (GMM theory) at  $k_0=0.3$  and different values of  $g$**

Let us study the dependence of discount rate  $i$  on leverage level  $L$  in Generalized Modigliani–Miller theory (GMM theory) at  $k_0=0.3$  and different values of  $g$ .

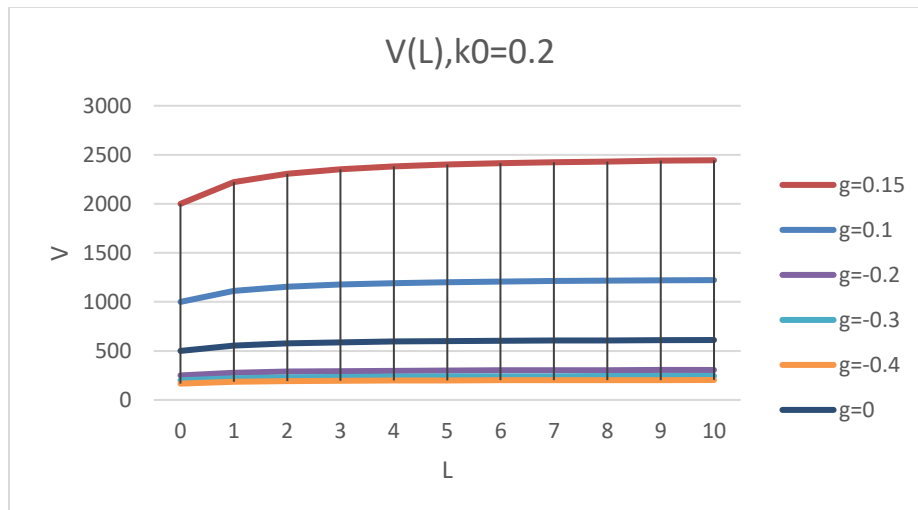



Figure 12: Dependence of company value V on leverage level L in Generalized Modigliani–Miller theory (GMM theory) at  $k_0=0.2$  and  $g = 0; 0.1; 0.15; -0.2; -0.3; -0.4$

From Fig.12, it is seen, that at  $k_0=0.2$  and  $g = 0; 0.1; 0.15; -0.2; -0.3; -0.4$  the company value V at fixed growth rate g increases with leverage level L in Generalized Modigliani–Miller theory (GMM theory). The company value V as well increases with growth rate g.

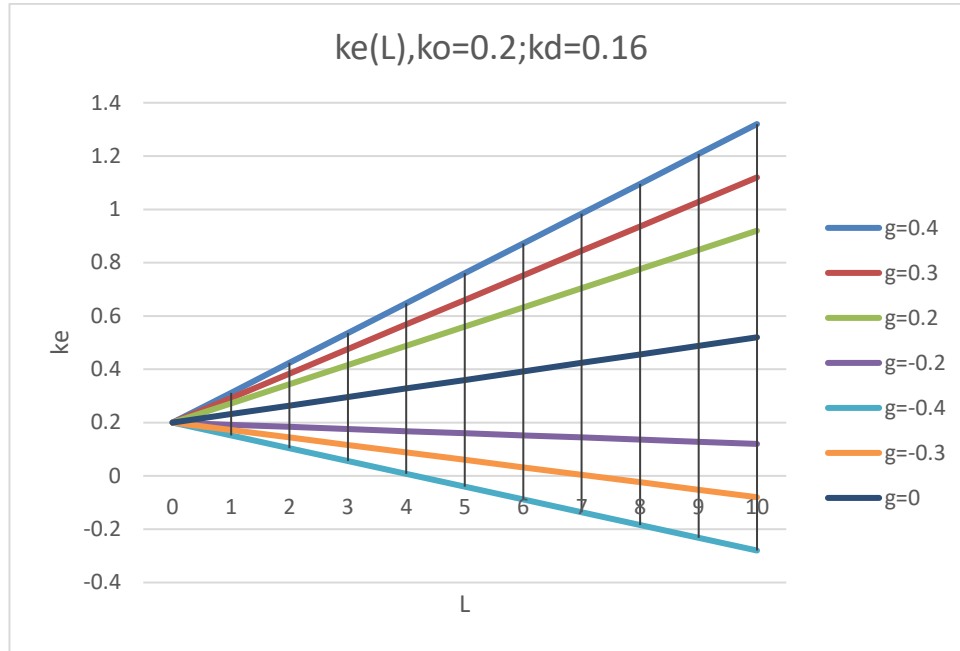

Figure 13: Dependence of equity cost  $k_e$  on leverage level L in Generalized Modigliani–Miller theory (GMM theory) at  $k_0=0.2$ ;  $k_d=0.16$  and  $g = 0; \pm 0.2; \pm 0.3; \pm 0.4$

We have investigated the dependence of equity cost  $k_e$  on leverage level L in Generalized Modigliani–Miller theory (GMM theory) at  $k_0=0.2$  and  $g = 0; \pm 0.2; \pm 0.3; \pm 0.4$ . From Fig.13 it is seen that the equity cost,  $k_e$ , which linearly grows with leverage level L increases with g: the tilt angle  $k_e(L)$  grows with g. It is interesting, that at  $k_0=0.2$ ;  $k_d=0.16$  and at  $g^* = -0.16$  in accordance with formula

$$g^* = -\frac{(k_0 - k_d) \cdot (1 - T)}{T}$$

the equity cost  $k_e$  turns out to be equal to  $k_0$  and does not change with leverage level L.

This should change the dividend policy of the company, because the economically justified value of dividends is equal to equity cost.

**The Case of Brusov–Filatova–Orekhova Theory**

*Calculations of the discount rate, WACC–g*

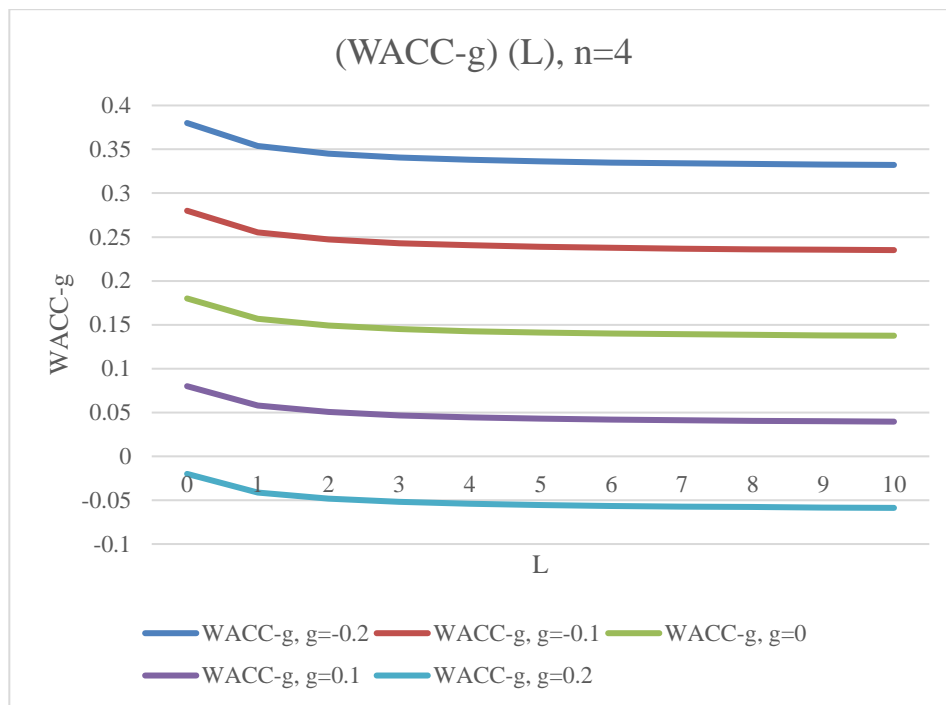

Figure 14: The discount rate,  $WACC-g$ , depending on the level of leverage  $L$  at different growth rates  $g=-0.2; 0.1; 0.0; -0.1; -0.2$  in Generalized Brusov–Filatova–Orekhova theory (GBFO theory) at  $k_0=0.18; k_d=0.16; t=0.2$  for four –year company

As it could be seen from Figure 14 all the curves  $(WACC-g)(L)$  with leverage level  $L$  at all  $g$  values. The  $(WACC-g)$  values at fixed leverage level  $L$  decrease with growth rate,  $g$ . This means that  $WACC-g$  is a suitable candidate for the discount rate.

As in the case of the two–year company, explaining the behavior of  $(WACC-g)(L)$  with  $g$  growth can be as follows: all  $WACC(L)$  curves originate from the same point ( $L=0; WACC=0.18$ ). The  $(WACC-g)(L)$  curves will be ordered as follows for  $L=0$ : the larger  $g$ , the lower the starting point and hence the entire graph lies, since the curves do not intersect. As we’ll see below the decrease of  $(WACC-g)(L)$  with growth rate,  $g$ , will lead to increase of the company value,  $V$ , with  $g$ .

**Calculations of the company value,  $V$**

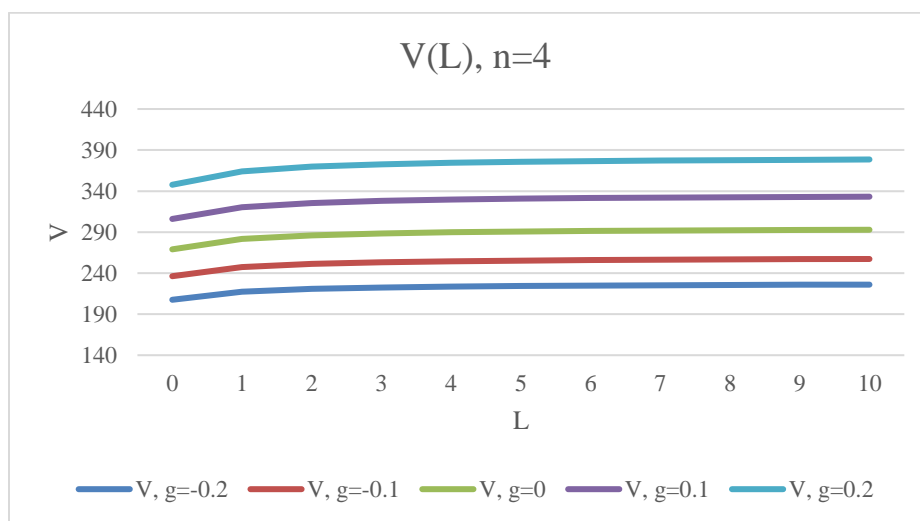

Figure 15: The company value,  $V$ , depending on the level of leverage  $L$  at different growth rates  $g=-0.2; 0.1; 0.0; -0.1; -0.2$  in Generalized Brusov–Filatova–Orekhova theory (GBFO theory) at  $k_0=0.18; k_d=0.16; t=0.2$  for four–year company

As it is seen from Figure 15, the company value  $V$  at fixed growth rate  $g$  increases with leverage level  $L$  in Generalized Brusov–Filatova–Orekhova theory (GBFO theory). The company value  $V$  as well increases at fixed leverage level  $L$  with growth rate  $g$  at fixed. This is a consequence of a decrease in the discount rate  $(WACC-g)(L)$  with an increase in the growth rate  $g$ . Comparing with the results for the two year old company, we see that the value of the company  $V$  increases with the age of the company: we have a range of 149 to 157 with  $L=1$  for  $g$  from  $-0.2$  to  $0.2$  for the two year old company and a range of 217 to 364 with  $L=1$  for  $g$  from  $-0.2$  to  $0.2$  for a four year old company. And this is the obvious conclusion, because it is well known, that the value of any asset (company, stock, bond etc) is equal to the sum of the discounted returns generated by this asset. Since this value is proportional to the lifetime of this asset, the capitalization of the company will grow with its age.

The dependence of the cost of equity  $k_e$  on the level of leverage  $L$  in the Generalized theory of Brusov–Filatova–Orekhova (GBFO theory) was studied below for a four–year company with growth rates  $g = 0; \pm 0.1; \pm 0.2$ .

**Calculations of the cost of equity  $k_e$**

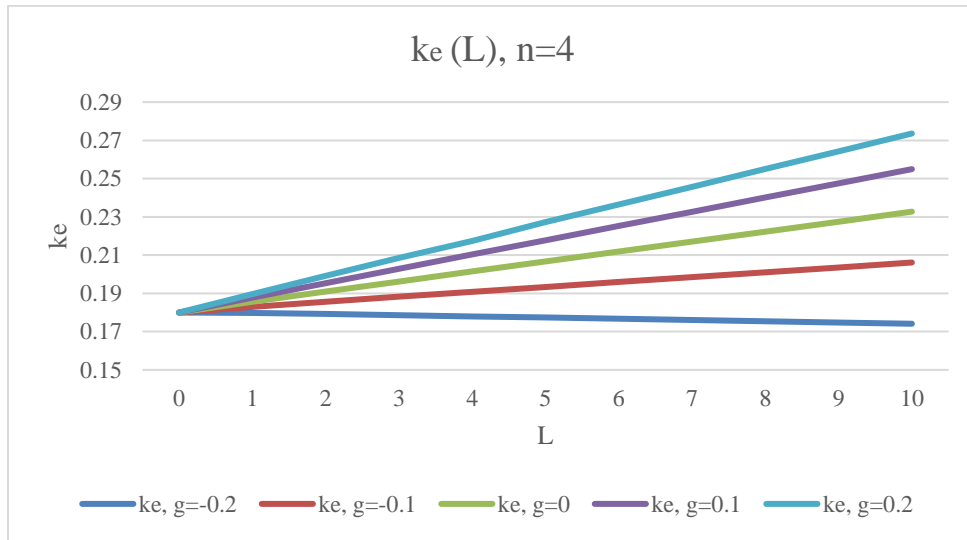

Figure 16: The equity cost,  $k_e$ , depending on the level of leverage  $L$  at different growth rates  $g=0.2; 0.1; 0.0; -0.1; -0.2$  in Generalized Brusov–Filatova–Orekhova theory (GBFO theory) at  $k_0=0.18; k_d=0.16; t=0.2$  for four–year company

From Figure 16 it can be seen that the cost of equity  $k_e$  increases practically linearly with leverage level  $L$  at all growth rates  $g$  (except for  $g=-0.2$  where we see a decrease in  $k_e$  with leverage level  $L$ ). The slope angle  $ke(L)$  increases with  $g$ . This should change the dividend policy of an enterprise with variable profit, since economically the reasonable amount of dividends is equal to the cost of equity.

But the biggest change in the company's dividend policy is related to the discovery of a qualitatively new effect in corporate finance: at a rate  $g < g^*$ , the slope of the  $k_e(L)$  curve turns out to be negative (one can observe this effect here for  $g=-0.2$  where a decrease in  $k_e$  with leverage level  $L$  takes place). This effect, which is absent in the classical Modigliani–Miller theory and the classical Brusov–Filatova–Orekhova theory with constant profit, exists in the Modigliani–Miller theory with variable income and in the Brusov–Filatova–Orekhova theory with variable income at a certain age of the company,  $n$ , which exceeds some cutoff age value  $n^*$ . The latter effect is similar to a qualitatively new effect in corporate finance, discovered by Brusov–Filatova–Orekhova within the framework of the BFO theory: anomalous dependences of the cost of equity  $k_e$  on the leverage level  $L$  when income tax  $T$  exceeds a certain value  $T^*$ : this discovery also significantly changes the principles of the company's dividend policy.

**CONCLUSIONS**

The Brusov–Filatova–Orekhova (BFO) theory of capital cost and capital structure as well as the theory by Nobel Prize winners Modigliani and Miller (perpetuity limit of BFO theory) consider the case of constant income, while in practice profit of the company is, of cause, variable. Recently we have generalized the latter for the case of variable profit, and here we have generalized for the first time the Brusov–Filatova–Orekhova theory for the case of variable income.

This generalization significantly expands the applicability of this modern capital structure theory, valid for companies of any age, in practice, in particular, in corporate finance, in business valuation, in investments, in banking, in ratings, etc.

We have derived the generalized BFO formula for WACC and this consists a main theoretical result of a current paper.

From this formula and as well from using this formula in MS Excel, we show that the role of the discount rate shifts from WACC to  $WACC-g$  (where  $g$  is the growth rate) for financially dependent companies and from  $k_0$  to  $k_0-g$  (for financially independent companies). While WACC increases with  $g$ , the actual discount rates  $WACC-g$  and  $k_0-g$  decrease with  $g$  and, accordingly, the company value,  $V$ , increases with  $g$ . For the cost of equity  $k_e$ , the slope of the curve  $k_e(L)$  increases with  $g$ . Since the cost of equity determines the economically justified amount of dividends, this should change the company's dividend policy. It turns out that at the rate  $g < g^*$  the slope of the curve  $k_e(L)$  becomes negative, which can significantly change the company's dividend policy principles. This means the qualitatively new effect discovery in corporate finance.

Bringing existing financial models closer to real practice is the most important challenge in precision finance. Over the past couple of years, the two main theories of the capital structure (Brusov–Filatova–Orekhova (BFO) and Modigliani–Miller (MM)) have been adapted to the established financial practice of the functioning of companies, taking into account the real conditions of their work. They are generalized to the case of variable income, to paying income tax with arbitrary frequency, to the advance payments of income tax etc. Taking these effects into account significantly changed the results of both theories and brought both theories closer to reality. This allows the company's management to make the right management decisions, reduces the risks of losses and bankruptcy and, in general, makes the economy more stable and less susceptible to the risks of global crises.

### REFERENCES

- Brusov, P., Filatova, T., & Orekhova, N. (2023). *The Brusov–Filatova–Orekhova Theory of Capital Structure: Applications in Corporate Finance, Investments, Taxation and Ratings*. Springer Nature.
- Brusov, P., Filatova T., (2021) T. *The Modigliani–Miller Theory with Arbitrary Frequency of Payment of Tax on Profit*. *Mathematics*, 9, 1198. <https://doi.org/10.3390/math9111198>
- Brusov, P., Filatova, T. (2022a) *Influence of Method and Frequency of Profit Tax Payments on Company Financial Indicators*. *Mathematics* 10, 2479. <https://doi.org/10.3390/math10142479>
- Brusov, P., Filatova, T. (2022b) *Generalization of the Brusov–Filatova–Orekhova Theory for the Case of Variable Income*. *Mathematics* 10, 3661. <https://doi.org/10.3390/math10193661>
- Brusov, P., Filatova, T. (2023) *Capital Structure Theory: Past, Present, Future*. *Mathematics* 11, 616. <https://doi.org/10.3390/math11030616>
- Brusov, P., Filatova, T., Chang, S.–I., Lin, G. (2021b) *Innovative Investment Models with Frequent Payments of Tax on Income and of Interest on Debt*. *Mathematics* 9, 1491. <https://doi.org/10.3390/math9131491>
- Brusov, P., Filatova, T., Kashirin, A. (2023) *An Assessment of the Financial Indicators of PJSC Gazprom*. *J. Risk Financial Manag.* 16, 339. <https://doi.org/10.3390/jrfm16070339>
- Brusov, P., Filatova, T., Kulik, V. (2022). *Benefits of Advance Payments of Tax on Profit: Consideration within the Brusov–Filatova–Orekhova (BFO) Theory*. *Mathematics* 10, 2013. <https://doi.org/10.3390/math10122013>
- Brusov, P., Filatova, T., Kulik, V. (2023) *Two Types of Payments of Tax on Profit: Advanced Payments and at the End of Periods: Consideration within BFO Theory with Variable Profit*. *J. Risk Financial Manag.* 16, 208. <https://doi.org/10.3390/jrfm16030208>
- Brusov, P., Filatova, T., Orekhova, N., Eskindarov, M. *Modern Corporate Finance, Investments, Taxation and Ratings, 2nd ed.*; Springer Nature Publishing: Cham, Switzerland, 2018; pp. 1–571.
- Brusov, P., Filatova, T., Orekhova, N., Kulik, V., Chang, S.–I., Lin, G. (2021a) *Generalization of the Modigliani–Miller Theory for the Case of Variable Profit*. *Mathematics* 9, 1286. <https://doi.org/10.3390/math9111286>
- Brusov, P., Filatova, T., Orekhova, N., Kulik, V., Chang, S.–I., Lin, G. (2022). *The Generalization of the Brusov–Filatova–Orekhova Theory for the Case of Payments of Tax on Profit with Arbitrary Frequency*. *Mathematics* 10, 1343. <https://doi.org/10.3390/math10081343>
- Filatova, T., Orekhova, N., Brusova, A. (2008). *Weighted average cost of capital in the theory of Modigliani–Miller, modified for a finite life–time company*. *Bull FU* 48:68–77.
- Filatova, T., Brusov, P., Orekhova, N. (2022) *Impact of Advance Payments of Tax on Profit on Effectiveness of Investments*. *Mathematics* 10, 666. <https://doi.org/10.3390/math10040666>
- Modigliani F., Miller M. (1966) *Some estimates of the cost of capital to the electric utility industry 1954–1957*. *Am Econ Rev*, 56, pp. 333–391.
- Myers, Stewart C. (2001) *Capital Structure; Journal of economic perspectives*, 15(2) p. 81-102.
- Brusov, P., Filatova, T., & Orekhova, N. (2020). *Ratings: critical analysis and new approaches of quantitative and qualitative methodology*. Springer Nature.

Brusov, P., Filatova, T., & Orekhova, N. (2022) *Generalized Modigliani–Miller Theory: Contributions to Finance and Accounting*. Springer Nature.

Brusov, P., Filatova, T., & Orekhova, N. (2023) *The Brusov–Filatova–Orekhova Theory of Capital Structure*.

Modigliani F., Miller M. (1958). *The cost of capital, corporate finance, and the theory of investment*. *Am Econ Rev*, 48, pp. 261–297.

Modigliani F., Miller M. (1963). *Corporate income taxes and the cost of capital: a correction*. *Am Econ Rev*, 53, pp. 147–175.

## Reinventing the Case-method Teaching Approach Using a New Technological Tool

Aijaz A. Shaikh <sup>1,\*</sup>  
Shabnam A. Shaikh <sup>2</sup>  
Heikki Karjaluo <sup>3</sup>

\*Corresponding author

<sup>1</sup> Senior Lecturer, University of Jyväskylä, Finland, [aijaz.a.shaikh@jyu.fi](mailto:aijaz.a.shaikh@jyu.fi)

<sup>2</sup> Doctoral Researcher, University of Jyväskylä, Finland, [shabnam.a.shaikh@jyu.fi](mailto:shabnam.a.shaikh@jyu.fi)

<sup>3</sup> Professor/Vice Dean, University of Jyväskylä, Finland, [heikki.karjaluo@jyu.fi](mailto:heikki.karjaluo@jyu.fi)

### ABSTRACT

We developed and implemented a visually based pedagogical approach called Visio case-method teaching (V-CMT). Data were collected from thirty business and management students using written statements, interviews, and in-class notes and observations. The data were analyzed using the inductive thematic analysis approach. Major findings suggest that V-CMT supports online learning, increases university student volume & value of learning, increases student engagement with the course content, and enhances information retention. Most of the participants suggested replicating this method in other courses. Major challenges in the implementation of V-CMT relate to a lack of time management, non-provision of a robust preamble, and limited knowledge of using MS Visio tools.

*Keywords:* ICEB, Case-method teaching, MS Visio tool, new pedagogy, student engagement, information retention.

### INTRODUCTION

Rapid innovations in information, communication, and media technologies have gradually transformed the learning atmosphere and motivated the development of new synchronous and asynchronous teaching and pedagogical approaches. Notable among these approaches are case-method teaching (CMT), dialogue teaching (Sedova, 2017), blended learning (Cocquyt et al., 2019), game-based learning (Lew & Saville, 2021), flipped or inverted classroom learning (Gómez-Tejedor et al., 2020), simulations (Farrell, 2020), instructional video clips (Expósito et al., 2020), podcasts (Hill & Nelson, 2011), and prime-time learning (Koskinen et al., 2018). Considering the novelty and effectiveness of these approaches, the pedagogical landscape in many higher education institutions has changed. However, contemporary contributions (Krishnamurthy, 2020; Suyunchaliyeva et al., 2021) have suggested that technological advancements are not the sole motivation for pedagogical innovations; rather, unprecedented situations, such as those created by the COVID-19 pandemic, have caused faculty to revisit their pedagogical methods and establish new routines while transitioning to online learning and audience participation.

Pedagogy—defined as any conscious activity by a person to enhance the learning of another (Bashabsheh et al., 2019, p. 714)—involves how to teach (well) and pedagogical developments (either online, in-class, or hybrid). These developments are now highly prone to unprecedented incidents, computer-related technological changes, and changes in the behavior of millennial, Gen-Z, and Gen-Alpha students (i.e., the mobile generation). Collectively, these new developments and changing student behaviors have created a highly challenging and demanding atmosphere in which higher education institutions and faculty must try to upgrade and diversify their delivery techniques to meet the ever-increasing expectations of students and facilitate learning using various innovative tools. Importantly, CMT has increasingly been recognized as an excellent pedagogical solution that allows students to experience real-life situations, which enhances their learning outcomes and course satisfaction (Dorta-Afonso, 2019). Similarly, a host of empirical and experimental research investigating various facets of technology in CMT has been published in renowned journals. For example, Shin, Brush, and Saye (2019) explored the use of case methods in teaching methods. They found that most of their respondents valued case discussions with co-construction of knowledge as useful and meaningful. Based on the revised Bloom's taxonomy, Nkhoma et al. (2017) proposed the use of case studies using four constructs: knowledge application, higher-order thinking, practice evaluation knowledge, and knowledge improvement. Their findings suggested that knowledge application creates a positive impact on student's higher-order thinking.

We have extended traditional CMT via a new visual tool called MS Visio. Although, Visio tools have been used widely in various disciplines including business analytics and business intelligence (cf. Shershakov, 2021), their usage in CMT has rarely been noticed. The purpose of supplementing CMT with the MS Visio tool is to systematically convert case text to a comprehensive diagram for future use; the diagram or visuals could then be used by students as a source document that would almost completely replace multiple pages of text. According to Vilnai-Yavetz and Tifferet (2015), a person can absorb visual images sixty times faster than words or text. Moreover, most of the previous empirical studies have examined new teaching approaches at the general or university level, we have examined teaching at the course level (Uiboleht et al., 2016).

The purposes of this study were to develop and implement a new and interactive pedagogical approach called Visio case method teaching (V-CMT) and to examine the extent to which V-CMT increases students' engagement with the course content and produces better outcomes or challenges for master's degree students in the Digital Marketing and Corporate Communication (DMCC) program. V-CMT aims to provide a more effective and contemporary visual-based learning environment for university students in the online and contact teaching atmospheres. Moreover, the major pitfalls and challenges to V-CMT based on the students' opinions were examined. The research questions proposed to achieve the objectives of this study include: 1) *How V-CMT benefit university students' learning, engagement, and satisfaction with the course content?* 2) *What are the major pitfalls of and challenges to the V-CMT approach especially during a global pandemic?*

Two research questions were proposed as the research objectives were also twofold: determining the benefits of and challenges to V-CMT. Research has used various terms to represent CMT (Afsouran et al., 2018), such as case, case method, case-based learning activities (Nkhoma et al., 2017; Popil, 2011), and case study teaching method (Popil, 2011). These terms are used interchangeably in this article. The remainder of this paper is structured as follows: Section 2 presents the case pedagogy and introduces V-CMT, the research methodology is explained in Section 3, the findings are discussed in Section 4, and the discussion and conclusion are described in Section 5.

## LITERATURE REVIEW

### Case Method and Case Pedagogy

Our many years of experience in academia and active publishing in the field of digital sciences and mobile technologies have led us to conclude that university students usually prefer to acquire a set of abilities and skills that can help them achieve and even surpass the academic knowledge and essential skills needed to survive and thrive in a highly competitive and diversified automated workplace. Consequently, the historical classroom-based, face-to-face CMT and online synchronous teaching strategies with passive teaching are quickly losing their usefulness. Considering this shift, the demand for a more skilful and innovative workforce compelled several universities to define their vision for the future of education and student learning (Organization for Economic Co-operation and Development, 2018; Herodotou et al., 2019) by insisting on improving learner qualities, the acquisition of necessary skills and the use of various digital tools and techniques. A growing number of scholars (cf. Clifton & Mann, 2011) also agreed that students are becoming the most potent stakeholders of education, demanding up-to-date, interactive models of teaching and support. Consequently, the traditional model of education, teaching and pedagogy is quickly shifting, and necessary changes are being introduced in pedagogical and guidance practices to increase student learning and competencies (Jääskelä & Nissilä, 2015). Among the prominent changes, CMT has been proven to be one of the best pedagogical solutions, bringing students close to real-life situations and thereby increasing their engagement with the course content and their satisfaction with the course, and improving the learning outcomes (Dorta-Afonso, 2019). The case method is considered a foundational technology in business education (Rippin et al., 2022) and CMT involves the use of cases for classroom teaching purposes to encourage the students' active participation, which will improve their satisfaction with the course and their learning outcomes (Roy & Banerjee, 2012). A case in CMT should not be considered an example or an empirical or case study (Ray, 2018); rather, a case in this method is a real-life story, event or issue that is usually unresolved and provocative in nature, does not lay down analytical methods and invites students, usually in groups, to read, analyse and engage in a process of case evaluation and decision making. CMT, therefore, helps students develop critical thinking, decision-making, teamwork, group dynamics and long-term information retention skills (Bruner, 2002). According to Carlson and Valenchik (2006), CMT has three essential components: a detailed description of the situation or case, the students' preparation for discussing the case and discussion of the case in the classroom for possible resolution.

Popil (2011) encouraged the use of CMT, which has received mixed opinions about its effectiveness in increasing student learning, satisfaction, and engagement as well as its promotion of critical thinking. For example, to achieve a high level of student satisfaction, Dorta-Afonso (2019) designed a seven-session case method intervention to be used as part of an organizational behavior course and found that the participants were satisfied with the case study method, which resulted in the suggestion that this teaching method should be applied in other courses. However, it remained unclear whether the case method was appropriate for teaching certain areas of study, such as marketing, accounting, finance, and information systems (Shugan, 2006). Earlier, Powell (1994; 2000) found that CMT was a sophisticated form of instruction, but it did not allow the instructor to cover as much content as the traditional lecture method. While delving further into the limitations of CMT, prior research (Popil, 2011) suggested that CMT is a time-consuming and complex teaching method with a limited scope. The proponents of CMT, such as Harvard Business School, have remained supportive of CMT's effectiveness in classroom teaching and sharing by way of exercising leadership and teamwork while solving real problems and persuading students to think differently (Shugan, 2006).

### V-CMT – Introduction and Motivation

Humans are adept at assimilating visual content and digital technologies including mobile technologies enable an ample learning resource (Svendsen & Svendsen, 2019). Recent studies (Expósito et al., 2020; Shin et al., 2019) have stated that the use of digital technologies combined with visual tools and online videos and resources (e.g., TED talks, Student Mimicpro simulation, and Khan Academy) have revolutionized teaching, pedagogy, and the classroom learning environment. Research (Scull et al., 2016) has also revealed that online education reduces the operational costs of universities and encourages students to take courses at their convenience. This trend is growing at an exponential rate, and higher education institutions are increasingly adapting to these changes i.e., using digital technologies in their everyday teaching. The higher education institutions are also encouraging



their faculty to participate in and learn new ICT-based synchronous and asynchronous pedagogical practices and ensure their implementation in both online and classroom settings. In the same vein, visual modelling, which was traditionally used in the IT and IS courses, including software engineering, is now being used in several management and business courses to better present concepts with the help of some visual content. The standard language used in visual modelling is called unified modelling language (UML) (Shumba, 2005). Two UML tools are used in teaching: Rose and MS Visio. Between these two tools, MS Visio, which is based on the drag-and-drop method, is considered more convenient and instinctive for most students (Shumba, 2005). In addition to its instinctive nature, several other factors motivated us to develop and implement the V-CMT approach, including the ones shown below.

1. Introducing this modified V-CMT and embedding it into everyday teaching aims to meet the changing expectations of digital native contemporary students for more tech-oriented and innovative pedagogy that differs from the traditional text-based CMT approach.
2. The hallmark of CMT is active participation by students. V-CMT was developed and suggested based on this element.
3. With the inception of podcasts, YouTube (social media), and Vimeo business models, which primarily rely on producing and sharing video content free of cost, came to a transformation in student behavior. Instead of reading text-based material, blogs, and market reports, students prefer to watch videos as well as review images, diagrams, and tables, which increase their understanding of a particular phenomenon, create more interest than relying on text-based content, increase student engagement, and relieve their cognitive resources.
4. Given that most IT tools are easily and frequently accessed and used globally, this innovative and highly interactive CMT method can easily be replicated in all countries.

Following the synchronous and asynchronous nexus, the V-CMT process comprised three stages. In the first stage, traditional CMT included PowerPoint slides with synchronous class participation. Here, the students were given an understanding of the core concepts involving a particular phenomenon or case. Afterward, they were given a real business case and a detailed factual description of a business issue faced by an organization (Shugan, 2006). All the material relating to the case study and necessary instructions were placed online using the Moodle learning management system to facilitate asynchronous learning. These case studies comprised several pages and an appendix. We discussed the case with the students and determined an appropriate action. In the second stage, the course participants were divided into small groups of five members each. Each group was given a specific section of the case to read and discuss within their group to develop their understanding. In the third stage, we explained the Visio application, used the tools, and began depicting the case in a diagram. At the end of this session, the students left the class with a diagram that summarized the case. It consisted of several pages and an appendix. Unlike text, a diagram simplifies information as well as increases students' understanding. A diagram will also yield better retention of learned material (Figure 1 depicts the V-CMT process using Visio tools.)

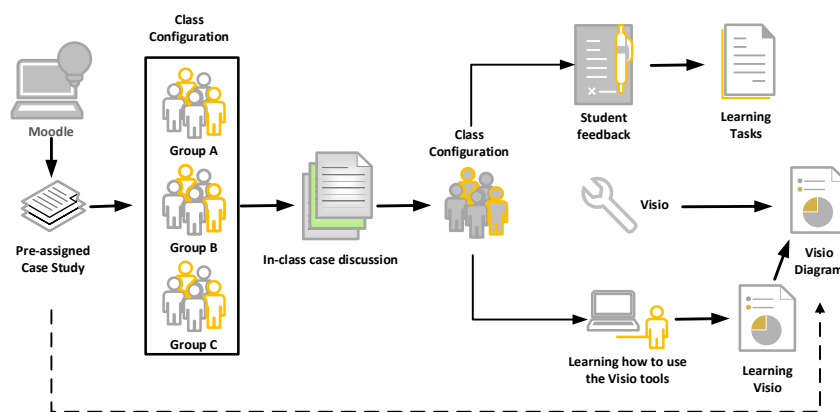

(MS Visio tools were used to develop this diagram)

Figure 1: Transition from CMT to V-CMT

## METHODOLOGY

### Case Selection and Description

In an era of fast digitization of products and services and the emergence of a networked economy and social media, understanding digital technologies is paramount to the survival and growth of students in the business world (Hanafizadeh & Shaikh, 2021). In line with these expectations, the universities in Finland introduced new master's programs such as DMCC.

The purpose of introducing DMCC was to meet tech-savvy students' varying needs for new technological tools in the marketing and corporate communication fields, thereby preparing them for the job market. New courses, such as Digital Marketing in Action, Digital Interaction, Digital Technologies & User Behaviour (DT&UB), and Digital Marketing Communication, were

developed and included in the DMCC program. Efforts were made by designated faculty members to revisit their pedagogical approaches and develop improvements. V-CMT was introduced in the DMCC course DT&UB, which is offered in the first year of the program during the spring semester. To guarantee a complete representation of participants, we initially utilized a method of purposive sampling. This strategy suggested by Shaikh et al (2023) provides a larger and more diverse group of participants with valuable various perspectives and experiences. Subsequently, within this cohort of participants, we applied the principle of randomization to select a subset of 7 students both male and female. This combination of purposive and random sampling ensured a fair and inclusive selection process for our study.

To understand the usability and effectiveness of V-CMT on student learning, an empirical case setting was designated for monitoring in spring 2021. In total, 30 students registered and participated in the DT&UB course. Three case studies were shared with the students in the class. At the outset, the students were informed about this new V-CMT approach as well as its implementation strategy, which was divided into three phases.

In *phase one*, the case studies were uploaded to Moodle (an online learning environment) for easy access and retrieval at least three days before the scheduled class. The class was divided into small groups of four or five members each. Each group was responsible for reading as well as critically analyzing the case study's content at their convenience. During the class, team members were randomly selected to share their opinions about the case and suggest possible solutions. To promote a healthy and meaningful discussion and support knowledge co-creation in the class, the designated faculty used various tools, including the whiteboard and MS Word, to record the students' comments and views. In *phase two*, the groups were dismantled, and all students were told to read the same case study individually and refresh their ideas and thoughts. Students were then invited to record their views while the designated faculty began depicting the case study in an easy-to-comprehend single diagram using the Visio application. In the *third phase*, a brief training on the use of the Visio application, which was also part of the V-CMT implementation strategy, was provided for the purpose of raising the students' skill levels and keeping them engaged and involved in this new teaching method.

### Material and Methods

To the best of our knowledge, little is known about using visual tools when delivering a course in a university setting; the empirical research in this direction is sparse. When little is known about a specific phenomenon or practice in question, it is highly advisable to use the qualitative approach (Weng et al., 2020). The primary data, including written statements, interviews, and classroom notes/observations were collected during the spring 2021 semester. The data collection process was divided into two phases. During phase one, the students were advised to write and submit a one-page learning diary sharing their learning experience with V-CMT. Students were offered extra credit (5%) for completing this task. To receive meaningful feedback on V-CMT, all students were explicitly asked to answer the following questions when writing and submitting their learning diary:

- How did you find V-CMT?
- Did V-CMT increase your volume of learning about a specific case study?
- Did V-CMT provide a complete picture of the case?
- Did V-CMT make it easy to remember and retain the information in the case study?
- Was the diagram that was developed at the end of using V-CMT easy to comprehend?
- What was flawed or complicated about V-CMT? And would you support the continued use of V-CMT in this course as well as replicating the same procedure in other courses/disciplines?

In phase two, seven students were randomly selected and invited for an in-depth, semi-structured interview concerning V-CMT. In qualitative research, particularly in studies based on content analysis, the concept of data saturation is used to determine the sample size (Namey et al., 2016). This concept enables researchers to avoid dealing with redundant information. Guest et al. (2016) argued that data saturation is obtained by conducting 6–12 interviews. In our case, we were able to stop the analysis after seven interviews when it became clear to us that no new information, code or topic could be derived from the data obtained. Table 1 contains the demographic profiles of the interview participants.

Table 1: Demographic profile

Name (Pseudo)	Gender	Profession	Age
Sali	M	Master's degree/DMCC student	20–24
Maria	F	Master's degree/DMCC student	20–24
Sanna	F	Master's degree/DMCC student	25–29
Mikka	M	Master's degree/DMCC student	25–29
Max	M	Doctoral student	30–34
Robert	M	Doctoral student	30–34
Meera	F	Master' degree student	25–29

Amid COVID-19 fears, all study participants who were selected for the interview were asked to join the interview online via the Zoom application. After obtaining the necessary consent, the Zoom interviews were recorded and used during the interview

transcription process. The average duration of the interviews was 20 minutes, and they included the same questions that were asked during the learning diary assignment plus one supplemental question: Compared to other case study or teaching methods, how motivated were you in participating in class discussions that involved the V-CMT approach? The inductive data analysis technique was used to analyze the data collected during phases one and two to find patterns and themes. The collected information and observations were analyzed using the content analysis technique.

### Data Analysis

Considering the nature of the primary data, including the learning diaries, classroom observations, and the opinions collected during the interviews, we used the bottom-up inductive thematic approach to analyze the data. We followed the six-step thematic analysis process as proposed by Braun and Clarke (2006) and explained below. All the interviews, learning diaries, and notes (observations) were thoroughly examined. Each respondent was given a unique participant identification number. The data were transferred from an MS Word document to an Excel sheet. The themes and associated sub-themes that emerged from reading and rereading the transcripts and diaries were given codes. The codes were then sorted to determine the prevalence of a theme when comparing it to other themes. Finally, names and meanings were also assigned to the themes. In total, five themes were identified: volume and value of learning, engagement, information retention, continuous or future usage of V-CMT, and pitfalls and challenges of using V-CMT.

## FINDINGS

### Students' Learning

Increasing students' learning experiences is the ultimate goal of every pedagogical approach. Thus, the V-CMT method was developed and deployed to increase our understanding of how much students' understanding of case studies and learning larger frameworks could increase with visual learning. For this specific study, the benefits were measured via two parameters: the volume or quantity of learning and the value or quality of learning. The feedback, which was received via learning tasks and interviews, suggested that V-CMT helped students organize information into quickly comprehensible bulleted lists and tables as well as interactive shapes and schemes. V-CMT also made the learning atmosphere more active and effective; the pictures explaining the cases were considered useful and friendly, and V-CMT was found handy and productive.

*"Humans are good at assimilating visual content, and I have noticed that, to me as well, learning visually is [a] good approach. I liked when we discussed and concluded cases in Visio. I think that it was easy to understand the main points of the cases when we did the diagrams together in class. They are clear, and you can see connections between different elements. Besides, learning how to use [the] MS Visio application was highly encouraging and motivating for me (Maria, female, learning task)."*

The course participants supported this CMT and found it a good way to learn, especially for those who are more visual learners. Visualization allows students to increase their learning as well as their understanding of cases that are discussed and visually presented in class. Moreover, as described by the course participants, a sufficient amount of information was available on the diagram, which was immediately understandable.

*"All in all, I liked the method a lot. It was nice that we discussed the cases in this way because I have not seen anybody else use this kind of study method. [It is] too bad that we did not have time to go through all the original cases because it would have been nice to use Visio even more. Maybe some other time (Meera, female, interview transcript)."*

*"The purpose of this paper was to give feedback on whether using MS Visio in this course was beneficial from the student's perspective, and I genuinely think it was. I found it very helpful to rehearse the article contents from the diagrams made with MS Visio. Thus, it can be stated that using this method increased my learning and understanding of the cases that were addressed in this course (Mikka, male, learning task)."*

### Students' Level of Engagement

Contemporary research on learning and teaching in higher education context has focused on how to increase the greater levels of student engagement (Christie & Morris 2021; Heilporn & Lakhal, 2021). Introducing a new teaching method that departs from traditional methods could provide several benefits, including students' increased engagement and class participation. The students' level of engagement with V-CMT was explicitly examined. Some of the course respondents stated that V-CMT summarizes the main points of a case study or article in a reasonable way, which allows anyone using it to rehearse the most important takeaways of the article in a straightforward fashion.

*"I like the visualization of the content of the case study with the Visio method. The colors and the forms are used appealingly and directly provide a good overview of the structure/mind map. Additionally, I also liked the usage of icons (e.g., computer symbols, etc.), which kept me engaged as well as helped me understand the overall content (Max, male, interview transcript)."* Most of the students stated that Visio's highly interactive features kept them engaged with the case study and increased their level of participation in class discussion. One student also stated that another benefit of V-CMT is its usefulness and ease, which increased their understanding, comfort, engagement, and interest in CMT.

*"It is a great tool that shows complicated tables concerning various aspects. It is useful and easier for students to follow when everything is gone through step by step using the tool and not showing only [a] huge table [that] contains theory for 20–30 mins. It makes things more understandable (Sali, male, learning task)."*

*“Because V-CMT makes things easy for me, I know what we are talking about, and I can engage at any time since everything is there on a diagram right in front of my eyes. It generates and develops more ideas on the way, and when I see the diagram is being developed so automatically, the brain starts engaging, developing, and building new ideas. I appreciate it myself (Robert, male, interview transcript).”*

*“It seemed to help with engaging the students because we were participating in creating the content for the class. It is also always a good thing to learn about new technological tools in the context of the class (Sanna, female, interview transcript).”*

### **Students’ Information Retention**

Considering how much information students can easily digest from a new delivery or teaching method is key to the successful development and implementation of a new pedagogy. Visio offers a variety of options, tools, and customized icons and shapes. These functions could help students quickly understand the case diagram as well as retain the information or content for class quizzes and exams with the help of a single comprehensive diagram. The students were asked explicitly about the role of V-CMT in retaining information or content from the case study. Most agreed that V-CMT helped them retain the primary learning outcomes of a particular case study for a longer duration, which will help them prepare for exams and write thesis projects.

*“In V-CMT, we were not simply learning by heart; we were using our heads in analyzing the situation, and that helps a lot in retain[ing] a larger volume of information and later its use during the exam and thesis writing. When it comes to information retention, V-CMT is a very good method (Meera, female, interview transcript).”*

Some students stated that it was easy for them to understand and retain the main points of the cases when looking at the diagram in class. They found the diagrams an easy way to study and understand long articles because the diagrams depict all the important points. The following quotations were drawn from the class participants’ comments on information retention, especially about the exam:

*“Revising the case diagram for the exam was very nice and made my life easier. I do not prefer written exams, which usually require memorizing text, as [is] the case with other courses in my master’s degree program. However, the Visio tool was useful because it summarized the main points of the case studies into diagrams. Therefore, it was easy to retain most of the information and possible to get back to the topic by checking only the diagrams when reading the exam (Max, male, interview transcript).”*

*“I think that it was straightforward to understand the main points of the cases when we did the diagrams together in class. They are very clear, and you can see connections between different elements. And diagrams are also an easy way to retain the information and avoid reading long articles [for] the exam. So, I don’t see any negative sides while using Visio (Richard, male, learning task).”*

### **Future Usage of V-CMT**

The continuity of the newly developed pedagogy method is the hallmark of its successful implementation and usefulness. In addition to examining the volume and value of learning and student engagement and information retention, future use of V-CMT was also examined and discussed with the participants. The students were asked how useful and productive it would be to prolong and expand the use of V-CMT in other courses, and most recommended its continued use in their class as well as its implementation in other courses/programs.

*“First, I thought I [did] not need the visualization because I read all readings completely. Afterwards, I realized that the visualizations are very helpful [for] understanding the overall messages of the papers. Therefore, in my opinion, the usage of Microsoft Visio was a very important part of the lecture. I was able to understand and retain the key learnings so much better. In conclusion, I would highly recommend using Microsoft Visio in future lectures as well (Joe, male, learning task).”*

The opinions collected from the students favored the use of new tools in today’s online and classroom teaching with the aim of transforming student experiences and learning as well as increasing their digital literacy.

*“We are evolving, and so [are] the teaching methods. As a student, I don’t find it useful [to] keep the notes of every lecture. We are not robots; we are human beings. V-CMT is a very good and innovative addition to the existing teaching methods, and it should be further refined and used in future semesters as well. [The] combination of visuals and case method teachings is just a perfect combination, which can equally support online and classroom teaching (Maria, female, interview transcript).”*

### **Pitfalls and Challenges**

Every teaching method is not proven useful, and not all pedagogies produce the required results. The same logic applies to V-CMT. When the students were invited to share their opinions about the pitfalls they observed and the challenges they faced while working with this teaching method in class, they emphasized a lack of time management, a non-robust preamble, and the absence of prior training on using MS Visio tools as the biggest issues.

*“The students should learn how to use the Visio tool themselves first in the class, and then the teacher should start with V-CMT. Although there are various tutorials available on YouTube and other social media channels, it would be very helpful to learn it in the class (Abdul, male, learning task).”*

*“One of the biggest challenges that I found myself is that since we were required to compress a lot of information in a short time, it is a difficulty when comparing it with other methods [where] we were supposed to write big paragraphs. More time should be given to the V-CMT method (Kailash, male, learning task).”*

The study participants also indicated that they were easily distracted by other activities while the teacher was developing the diagram, which left little time for classroom discussion. One-way communication dominated the class during the diagram’s development, which highlights the major deficiency in this approach. The teacher should not dominate the discussion; rather, the participants should be trained in using the Visio tools, which will allow them to advise faculty during diagram development. Alternatively, the diagrams should be developed beforehand to allow more time for discussion when reviewing them.

*“It could be interesting for you to come up with a finished model/chart before the session, then start from scratch with the students during the class and compare what you did with what the students were offering. It could be interesting to discuss the differences and similarities and spark conversation (Satu, female, interview transcript).”*

*“In my opinion, a robust preamble explaining the key terms used in the case should be provided, and this will provide a good head-start to the students. Limiting the background information would be very, very critical for the students to understand the context of the study. It would sabotage the V-CMT effort, making it less useful for the students (Mukesh, male, learning task). names and affiliations are to be omitted from original submission.”*

## **DISCUSSION AND CONCLUSION**

The purpose of V-CMT is visual learning. This article examines the experiences of master’s degree university students at an accredited business school in Finland in response to the development and deployment of a new diagram-based CMT. The study used interaction during class, learning tasks submitted by students, and interview transcripts to identify five major themes: students’ volume and value of learning, level of engagement, and information retention along with future use possibilities, pitfalls, and challenges.

The results suggested that, unlike the case-teaching method, V-CMT transcended traditional pedagogical approaches and helped the participants increase their volume and value of knowledge, information literacy, engagement, experience, and participation to broaden their understanding of a specific case study. Most participants preferred diagrams, visual stimuli, and schemes (supported with different colors and shapes) over text, which indicated that future teaching methods and pedagogical developments could consider developing diagrams while conducting classroom/online teaching and learning sessions, which aligns with earlier findings reported by King (2016). Diagrams and visual images have widely been recognized as the “most dominant means of communication in contemporary young culture” (Gil-Glazer, 2020, p. 17). Therefore, determining whether a comprehensive diagram could successfully replace text when preparing for exams or writing master thesis projects was a major objective of V-CMT. The students’ feedback indicated that this objective was achieved on a large scale, and most students felt comfortable with the diagrams. Their feedback also reflected that they responded well to lecturers who used visual tools (King, 2016).

Future use of V-CMT was primarily supported by the study participants, which suggested its replication in other courses and programs could be positive. Regarding challenges associated with V-CMT, the study should be modified to allow more time for classroom discussion and the development of Visio use skills. This will increase V-CMT usability and functionality and prepare students for the job market due to Visio’s broad use and practical implications. The usability of these pedagogical methods could further enhance learning and student interactivity by embedding quizzes into classroom lectures as well as synchronous online lectures. Notably, the usability and the need for more innovative and interactive pedagogical and teaching methods will accelerate given the COVID-19 global pandemic, which has exerted a profound impact on the education sector (Krishnamurthy, 2020).

One of the significant implications of V-CMT is the rich platform offered by Visio, which can easily be integrated into various disciplines, such as management sciences, information sciences, and social sciences, in both the offline and online education contexts. Given the scalability features of V-CMT, this method could be recognized as an alternative teaching method. In addition to the university, vocational, and non-formal education sectors, the industry could also replicate V-CMT when designing and delivering education and training to significantly offset the effects of the COVID-19 pandemic.

Future research may collect more qualitative and quantitative evidence from postulating a future that justifies the need to promote diagrams and a visually based literacy culture at the university, vocational, and professional education levels, including a smart learning ecosystem, to support learner-centred pedagogy (Oyelere et al., 2020). This smart pedagogical trend may also help future research find the answers to critical questions, such as how gamification could benefit education; how animations and simulations could be developed and used as a useful teaching–learning resource; and how virtual reality and artificial intelligence tools and technologies in the classroom and online teaching could be valuable and practical for the student. In addition, without compromising the academic quality and standards of the curriculum, it would be interesting to learn how digitalization might

help academia lessen the novel and unprecedented challenges created by COVID-19 and prepare us for unforeseen pandemics to enable the continuance of learning.

## REFERENCES

- Allen, F., & Santomero, A. M. (1997). The theory of financial intermediation. *Journal of Banking & Finance*, 21(11-12), 1461-1485.
- Afsouran, N. R., Charkhabi, M., Siadat, S. A., Hoveida, R., Oreyzi, H. R., & Thornton III, G. C. (2018). Case-method teaching: advantages and disadvantages in organizational training. *Journal of Management Development*, 37(9-10), 711-720.
- Bashabsheh, A. K., Alzoubi, H. H., & Ali, M. Z. (2019). The application of virtual reality technology in architectural pedagogy for building constructions. *Alexandria Engineering Journal*, 58(2), 713-723.
- Braun, V., & Clarke, V. (2006). Using thematic analysis in psychology. *Qualitative Research in Psychology*, 3(2), 77-101.
- Bruner, R. (2002). *Socrates' muse: Reflections on effective case discussion leadership*. New York: McGraw-Hill.
- Christie, H., & Morris, N. (2021). Using assessed blogs to enhance student engagement. *Teaching in Higher Education*, 26(4), 573-585.
- Clifton, A., & Mann, C. (2011). Can YouTube enhance student nurse learning? *Nurse Education Today*, 31(4), 311-313.
- Cocquyt, C., Zhu, C., Diep, A. N., De Greef, M., & Vanwing, T. (2019). Examining the role of learning support in blended learning for adults' social inclusion and social capital. *Computers & Education*, 142, 1-19.
- Dorta-Afonso, D. (2019). Teaching organizational behavior in the bachelor of tourism through the case study method. *Journal of Hospitality, Leisure, Sport & Tourism Education*, 25, 1-7.
- Expósito, A., Sánchez-Rivas, J., Gómez-Calero, M. P., & Pablo-Romero, M. P. (2020). Examining the use of instructional video clips for teaching macroeconomics. *Computers & Education*, 144, 1-11.
- Farrell, C. (2020). Do international marketing simulations provide an authentic assessment of learning? A student perspective. *The International Journal of Management Education*, 18(1), 1-13.
- Gil-Glazer, Y. A. (2020). Visual culture and critical pedagogy: From theory to practice. *Critical Studies in Education*, 61(1), 66-85.
- Gómez-Tejedor, J. A., Vidaurre, A., Tort-Ausina, I., Molina-Mateo, J., Serrano, M. A., Meseguer-Dueñas, J. M., ... & Riera, J. (2020). Effectiveness of flip teaching on engineering students' performance in the physics lab. *Computers & Education*, 144, 1-11.
- Guest, G., Bunce, A., & Johnson, L. (2006). How many interviews are enough? An experiment with data saturation and variability. *Field Methods*, 18(1), 59-82.
- Hanafizadeh, P., & Shaikh, A. A. (2021). Developing doctoral students'/researchers' understanding of the journal peer-review process. *The International Journal of Management Education*, 19(2), 1-16.
- Herodotou, C., Sharples, M., Gaved, M., Kukulska-Hulme, A., Rienties, B., Scanlon, E., & Whitelock, D. (2019). Innovative pedagogies of the future: An evidence-based selection. *Frontiers in Education*, 4, 113.
- Heilporn, G., & Lakhil, S. (2021). Fostering student engagement in blended courses: A qualitative study at the graduate level in a business faculty. *The International Journal of Management Education*, 19(3), 1-13.
- Hill, J. L., & Nelson, A. (2011). New technology, new pedagogy? Employing video podcasts in learning and teaching about exotic ecosystems. *Environmental Education Research*, 17(3), 393-408.
- Jääskelä, P., & Nissilä, P. (2015). Identifying themes for research-based development of pedagogy and guidance in higher education. *Scandinavian Journal of Educational Research*, 59(1), 24-41.
- King, F. (2016). Visual approaches to property law pedagogy. *International Journal of Law in the Built Environment*, 8(1), 80-94.
- Koskinen, P., Lämsä, J., Maunuksela, J., Hämäläinen, R., & Viiri, J. (2018). Prime-time learning: collaborative and technology-enhanced studying with genuine teacher presence. *International Journal of STEM Education*, 5(1), 1-13.
- Krishnamurthy, S. (2020). The Future of Business Education: A Commentary in the Shadow of the Covid-19 Pandemic. *Journal of Business Research*, 117, 1-5.
- Lew, C., & Saville, A. (2021). Game-based learning: Teaching principles of economics and investment finance through Monopoly. *The International Journal of Management Education*, 19(3), 1-17.
- Namey, E., Guest, G., McKenna, K., & Chen, M. (2016). Evaluating bang for the buck: a cost-effectiveness comparison between individual interviews and focus groups based on thematic saturation levels. *American Journal of Evaluation*, 37(3), 425-440.
- Nkhoma, M.Z., Lam, T.K., Sriratanaviriyakul, N., Richardson, J., Kam, B., & Lau, K.H. (2017). Unpacking the revised Bloom's taxonomy: developing case-based learning activities. *Education + Training*, 59(3), 250-264.
- Organization for Economic Co-operation and Development (2018). *The Future of Education and Skills. Education 2030*. Paris: OECD Publishing.
- Oyelere, S. S., Silveira, I. F., Martins, V. F., Eliseo, M. A., Akyar, Ö. Y., Jauregui, V. C., ... & Tomczyk, L. (2020, April). Digital Storytelling and Blockchain as Pedagogy and Technology to Support the Development of an Inclusive Smart Learning Ecosystem. In *World Conference on Information Systems and Technologies* (pp. 397-408). Springer, Cham.
- Popil, I. (2011). Promotion of critical thinking by using case studies as teaching method. *Nurse Education Today*, 31(2), 204-207.
- Powell, R. (1994). From field science to classroom science: A case study of constrained emergence in a second-career science teacher. *Journal of Research in Science Teaching*, 31(3), 273-291.

- Powell, R. (2000). Case-based teaching in homogeneous teacher education contexts: A study of preservice teachers' situative cognition. *Teaching and Teacher Education*, 16(3), 389-410.
- Ray, M. (2018). Teaching economics using 'cases'—Going beyond the 'chalk-and-talk' method. *International Review of Economics Education*, 27, 1-9.
- Rippin, A., Booth, C., Bowie, S., & Jordan, J. (2002). A complex case: Using the case study method to explore uncertainty and ambiguity in undergraduate business education. *Teaching in Higher Education*, 7(4), 429-441.
- Roy, S., & Banerjee, P. (2012). Understanding students' experience of transition from lecture mode to case-based teaching in a management school in India. *Journal of Educational Change*, 13(4), 487-509.
- Scull, R., Thorup, J., & Howell, S. L. (2016). Review 10 trends impacting distance and continuing education, Part 1. *Recruiting & Retaining Adult Learners*, 18(4), 1-7.
- Sedova, K. (2017). A case study of a transition to dialogic teaching as a process of gradual change. *Teaching and Teacher Education*, 67, 278-290.
- Shaikh, S. A., Lämsä, A. M., & Heikkinen, S. (2023). Collaborative Leadership in the Institution of Higher Education: A Sociocultural Context of Pakistan. *South Asian Journal of Business and Management Cases*, 12(1), 65-80.
- Shershakov, S. A. (2021). VTMine for Visio: A Graphical Tool for Modeling in Process Mining. *Automatic Control and Computer Sciences*, 55(7), 847-865.
- Shin, S., Brush, T. A., & Saye, J. W. (2019). Using technology-enhanced cases in teacher education: An exploratory study in a social studies methods course. *Teaching and Teacher Education*, 78, 151-164.
- Shugan, S. M. (2006). Save research—Abandon the case method of teaching. *Marketing Science*, 25(2), 109-115.
- Shumba, R. (2005). Usability of Rational Rose and Visio in a software engineering course. *ACM SIGCSE Bulletin*, 37(2), 107-110.
- Suyunchaliyeva, M. M., Nautiyal, R., Shaikh, A. A., & Sharma, R. (2021). The use of mobile payment systems in Post-COVID-19 economic recovery: Primary research on an emerging market for experience goods. *Sustainability*, 13(24), 1-19.
- Svendsen, J. T., & Svendsen, A. M. (2019). Not for Free! An Analysis of Two Digital Tools Recommended as Learning Resources for Physical Education in Upper Secondary Schools in Denmark. *Scandinavian Journal of Educational Research*, 1-14.
- Uiboleht, K., Karm, M., & Postareff, L. (2016). How do university teachers combine different approaches to teaching in a specific course? A qualitative multi-case study. *Teaching in Higher Education*, 21(7), 854-869.
- World Economic Forum. (2017). "The global competitiveness report 2017-2018". Retrieved from <https://www.weforum.org/reports/the-global-competitiveness-report-2017-2018> (accessed 15 June 2023).
- Vilnai-Yavetz, I., & Tifferet, S. (2015). A picture is worth a thousand words: segmenting consumers by facebook profile images. *Journal of Interactive Marketing*, 32, 53-69.
- Weng, J., Hsieh, Y. C., Adnan, M. Z., & Yi, L. H. (2020). The motivation for Muslim customers' participation in the sharing economy. *Resources, Conservation and Recycling*, 155, 1-11.



## Research on Conceptual Design of Intelligent Products for Aquatic Plant Management in Urban River Channels

Yajing Hou <sup>1,\*</sup>  
Shengzhan Yan <sup>2</sup>  
Jie Wang <sup>3</sup>

\*Corresponding author

<sup>1</sup> Lecturer, Nanjing Institute of Technology, Nanjing, China, 455833106@qq.com

<sup>2</sup> Associate professor, Nanjing Institute of Technology, Nanjing, China, shengzanyan@njit.edu.cn

<sup>3</sup> Lecturer, Nanjing Institute of Technology, Nanjing, China, 34244119@qq.com

### ABSTRACT

Global warming and water eutrophication provide favorable living conditions for the rapid propagation of aquatic plants. The flooding of aquatic plants will lead to the obstruction of water navigation and the destruction of water ecological balance. According to relevant literature and market research, mechanical treatment is a more efficient way to solve the problem of aquatic plant flooding than manual removal. In order to solve the problems of aquatic plant inundation in small and medium-sized water areas such as inland rivers, the concept design of aquatic plant control product in the water air amphibious river course is carried out in this project combining with the technical advantages of artificial intelligence. Based on the previous literature research and product market research, the product characteristics are established and the functional structure design is carried out. Then, the design method of Industrial design bionics and product semantics is used to carry out the specific design of the product appearance and color matching scheme. Finally, a conceptual multifunctional water air amphibious aquatic plant control product with innovative concept, beautiful shape and integration of survey, cutting, storage and transportation is designed. The product can not only improve the efficiency and economic benefit of river aquatic plant treatment, but also improve the water environment of rivers and lakes. The research results indicate the direction for the product design and development of river aquatic plant treatment industry.

*Keywords:* Aquatic plant management, water air amphibious, intelligent, styling design, multifunctional design.

### INTRODUCTION

The negative impact of rapid economic development has exacerbated water pollution. Global warming and eutrophication of water bodies provide favorable living conditions for the rapid reproduction of aquatic plants (Zhang, 2017). Overflow of aquatic plants can lead to problems such as obstructing navigation on the water surface and disrupting the ecological balance of the water body (Zhao et al., 2022). Therefore, it will be particularly important to take certain measures to control aquatic plants.

Through literature review and analysis of relevant product research results, it is understood that traditional aquatic plant management products in the current market still have many limitations, specifically manifested in the large volume of equipment, high energy consumption, and limited to river and water bodies with diverse landforms. In recent years, with the development and progress of technology, intelligence, unmanned, and automation have become an inevitable trend and development direction for the design and research and development of numerous mechanical equipment. The existing similar products in the market already have the function of removing conventional aquatic plants, but they are relatively lacking in modern and advanced technology, and further design and development are needed.

Based on the existing problems of this type of product, this project aims to provide practical and innovative solutions and design ideas for the conceptual design of river aquatic plant management products. Firstly, this project has established a design concept for aquatic plant management products in water and air amphibious river channels, using small and medium-sized water bodies such as inland rivers as application scenarios, combined with the technological advantages of artificial intelligence, and based on the concept of "amphibious". Through extensive sketch design schemes, the design concept has been established. Furthermore, by analyzing and positioning the functionality of the product, a working principle and functional module that conforms to the product's characteristics are designed. In terms of appearance design, the design methods of industrial design bionics and product semantics are applied to specifically design the product appearance and color scheme. Finally, combined with the comprehensive application of various design software, a complete comprehensive design effect demonstration of the product design scheme is presented from the aspects of application scenarios, working principles, product details, explosive diagrams, etc.

This project aims to design a multifunctional amphibious aquatic plant management product with innovative concepts and beautiful appearance through the conceptual design of river aquatic plant management products. It can improve the water

environment of rivers and lakes while improving the efficiency and economic benefits of aquatic plant management in river channels. This research achievement points out the direction for product design and development in the river aquatic plant management industry. This topic also has certain limitations, as the product design scheme is a conceptual design, and the implementation of its functional design still requires rigorous scientific and market validation in the later stage.

## MARKET RESEARCH AND ANALYSIS OF AQUATIC PLANT MANAGEMENT PRODUCTS

### Overview of Aquatic Plants

All plants that can grow in water are collectively referred to as aquatic plants. According to their characteristics, they can be roughly divided into three categories: the bottom end is suspended in water, the top end leaves are in water and the bottom end is in mud, and the top end leaves are on water and the bottom end is in mud (Liu & Zhou, 2021). The structure of cleaning products required for cleaning different types of aquatic plants may also vary.

At present, the management and control methods for aquatic plants can be summarized into the following aspects (Zhang, 2020): 1. Water level regulation method: suitable for the management of small areas of water, with relatively high requirements, and requires manual regulation based on the growth cycle and season of aquatic plants. 2. Biological regulation method: Throw grass carp or other aquatic organisms that feed on water plants in water areas where water plants are rampant, thereby inhibiting the excessive reproduction of aquatic plants. This method requires sufficient understanding and analysis of the entire aquatic ecosystem, otherwise it will greatly damage the ecological environment of the entire system and cause population imbalance. 3. Chemical regulation method: mainly applies chemical herbicides to water areas where water plants are flooding. However, herbicides themselves contain toxicity, which not only kills aquatic plants but also directly harms other organisms in the water, and also leads to secondary pollution of the water body. 4. Physical regulation method: Physical harvesting is currently the most widely used method, which can be divided into mechanical harvesting and manual harvesting. It has relatively little damage to the ecological environment, and appropriate harvesting is conducive to a virtuous cycle of water surface ecology. Although manual fishing is relatively more flexible, it is time-consuming, labor-intensive, and inefficient, while mechanical fishing work efficiency will greatly improve.

### Current Development Status of Aquatic Plant Management Products Abroad

The research and development of aquatic plant harvesters in foreign countries has a long history, and countries such as the Netherlands began using specialized mechanical equipment for river aquatic plant cleaning operations as early as the 1950s. In the early years, they attached cutting devices to tractors or hydraulic excavators and fixed them on the shore to harvest cattails or other weeds in the river. After long-term verification, it has been found that this land-based lawn mowing method has many limitations in its scope of use, resulting in the emergence of a water grass mower that can travel on water (Wang, 2016).

With the increasing importance of water and grass management, more and more manufacturers and research institutions are paying attention to the research and development of grass cutting devices for underwater operations. The TYPE6400 water grass cutting boat invented by Berky Company in Germany is equipped with a striking cutting arm at the front of the hull, which can flexibly adjust the angle of the cutting blade, and the cutting depth can reach up to 1.5 meters or less. But it is not equipped with a water plant collection device, so the cut water plants will float directly on the water surface or sink to the bottom. The RS5000 model water grass harvesting boat invented by RS Planering in Finland can be used for both land and water, collecting floating garbage or aquatic plants on the water surface, and then driving to the shore to discharge the collected materials (Bian, 2016).

Since the 1980s, mechanical equipment suitable for small-scale river cleaning has been developed, and various single function models have been mass-produced and serialized overseas. Currently, their newly developed equipment is moving towards functional differentiation, miniaturization, multifunctional, and amphibious dual-use (Wang, 2016).

### Current Development Status of Aquatic Plant Management Products in China

China has also made certain achievements in the design and research of aquatic plant management products. At the beginning of this century, China began to vigorously design and research aquatic plant management products for small river channels. Considering that the river is not suitable for large machinery, ordinary hull combination cutting and conveying devices are often used for small water areas. In addition, according to different job requirements, functional accessories such as grab buckets and digging arms have also been developed. This type of method has undergone a closer research and design compared to traditional manual fishing. In addition, there are also small-scale integrated governance products, most of which have exposed mechanical structures and fixed operation and storage areas (Zou et al. 2018). When a certain storage capacity is reached, they return to the shore for unloading. This type of method is more suitable for relatively wide areas, but it will no longer be applicable for some complex and shallow water areas. At the same time, the exposed mechanical appearance cannot experience the aesthetic experience of modern social technology products. In addition to treatment products similar to ship hulls, amphibious aquatic plant treatment products have also emerged on the market, which can move freely in water and on the ground through tracks. Tracks have good adaptability to various terrains. This type of method has greatly improved the efficiency of cleaning, while also making corresponding improvements in appearance.

In recent years, some domestic manufacturers and research institutions have increased their research and design of water and grass management equipment. A representative example is the WH1800 river grass cleaning machine developed by Ningbo

Agricultural Machinery Institute in collaboration with Xiangshan Agricultural Machinery Factory and Shaoxing Agricultural Management Bureau. Its structure mainly consists of parts such as grass pulling device, cutting device, header, driving system, engine, transmission system, conveying device, hull, water grass working cabin, propeller propeller propeller, etc. (Xu, 2019). There is also a small river grass cleaning operation ship invented by Shanghai Electric Company, specifically designed for water hyacinths in river channels. It can also mechanically collect and salvage similar water plants and floating objects such as water peanuts, river duckweed, etc. Only one person is needed to operate and drive, and it is possible to harvest large areas of water and grass in a short period of time, with significant short-term results. The workboat is equipped with serrated cutting tools in front, which can easily hook and quickly cut the water hyacinth in front of it, and transport it to the interior of the cabin through an automatic conveyor belt. In the waters densely covered with water hyacinths, it only takes about ten minutes for a whole ship to complete a workload of nearly two tons, truly achieving labor-saving, labor-saving, and time-saving.

### **Analysis of Existing Problems**

Through literature review and product market research, it has been found that the main problems faced by current aquatic plant management equipment in river channels are three aspects. Firstly, the current cleaning methods for aquatic plants on the surface of small water bodies mainly rely on hiring labor to use small ships and traditional fishing tools for cleaning. This method has high labor intensity and low work efficiency. Secondly, the cleaning methods for large water bodies mainly use surface cleaning boats (such as water grass harvesters). Compared with small salvage boats, their work coverage and water grass removal efficiency are greatly improved. But this type of equipment has a complex structure, a large size, and high cost. Finally, due to the limitations of the ship's hull, the presence of aquatic plants in the middle of the water flow can be effectively resolved in both small and large water bodies. However, the removal effect is significantly limited in areas with shallow nearshore waters and more bends.

### **Future Trends of Aquatic Plant Management Products**

In summary, the water grass harvester is still in the development stage, from shore harvesting to water harvesting, and now to the integrated harvesting and processing mode, its functions are becoming increasingly perfect. However, compared to the current development achievements of garbage cleaning equipment, there is still great room for progress in this type of equipment. Therefore, the development direction of water grass cleaning devices can refer to the existing research results of garbage cleaning equipment to a certain extent, and research and development can be carried out from three aspects: miniaturization, continuous integration of operations, automation and intelligence.

#### **Miniaturization**

At present, the more common equipment is designed to be suitable for large areas of water with frequent contact between land and water, and to achieve large storage capacity, the equipment has a large volume. However, the freshwater river network is complex and has many tributaries, making it easier to establish connections with the land. Therefore, there is no need to be limited to the large-scale and high-capacity storage of equipment, and attention can be paid to the flexibility and efficiency of equipment to improve work efficiency. However, there is currently limited research on water and grass harvesting equipment for small areas of water, such as urban scenic areas, inland narrow rivers, fish and shrimp farming ponds, and there is still room for further research and development.

#### **Continuous Integration of Homework**

Some devices only have cutting functions and do not have the ability to temporarily store, resulting in frequent trips to and from the shore, affecting work efficiency. In addition, amphibious work vessels have replaced the form of manual transfer required for work vessels to dock on the shore, and the machinery itself can undertake subsequent material transportation work, reducing the consumption of labor and equipment caused by division of labor. Therefore, the continuous operation method that integrates cutting, conveying, and emission functions will definitely be favored.

#### **Automation and Intelligence**

At present, the most common water grass harvester on the market is still manually operated. However, with the development of small and medium-sized water grass harvesters and people's demand for labor liberation, the demand for automation and unmanned operation is also increasing. Moreover, combined with existing mature technologies, intelligence will provide more development possibilities, such as GPS navigation technology, infrared detection technology, and so on (Hu & Tang, 2022).

## **DESIGN ANALYSIS OF AQUATIC PLANT MANAGEMENT PRODUCTS**

### **Product Type Analysis**

Aquatic plant management products can be divided into three categories according to cleaning methods: interception and salvage type, cutting and conveying type, and surface roller type. The first two often use auxiliary equipment such as robotic arms, cutting devices, or conveyor belts to collect aquatic plants, while the latter uses the water pump provided by the device itself to create a pressure difference, allowing some floating aquatic plants to automatically gather into the device.

#### ***Intercepting and salvaging type***

This type of equipment has a small hull, making it easy to operate flexibly in various narrow curved waters. It only requires one person to drive, and the hull is not equipped with a compartment for storing water grass. It only has the functions of dredging and pushing dirt, and raking and conveying grass. These two functions are all completed by the mechanical arms

equipped in front of the hull, which are much wider than the hull. It can flexibly and quickly switch between the rake and the tool for cleaning water plants and pushing dirt to complete different work tasks. However, frequent ashore transportation of materials is required, resulting in low efficiency. The representative product is the intercepting and salvaging type sewage pusher produced by the Dutch company Converge.

#### ***Cutting and conveying type***

This type of equipment uses manual operation to clean water plants. The rolling rake installed at the front of the water plant collection cabin can cut large pieces of water plants. After cutting the water plants, they can be collected to the storage bin inside the ship through a conveyor belt connected to one end of the rolling rake. The connection device between the cutting tool and the hull can flexibly adjust the upper and lower positions of the rolling rake to adapt to the depth required by different cutting environments. The two sides of the ship are driven by open wheels, greatly reducing the probability of water grass entanglement. Represented by the ILH10-1000 water grass cleaning operation ship produced by Inland Lake Harvesters in the United States (Xu, 2019).

#### ***Surface roller type***

This product is designed from two men, Andrew Turton and Pete Ceglinski, who live in the coastal areas of Australia and suffer from floating garbage. They invented a garbage bin called Seabin that works on water. The garbage bin is equipped with a drainage hole and a water pump device. The water pump absorbs water to maintain the water level difference while continuously discharging the inhaled water, thereby driving the floating objects on the water surface to automatically enter the bin (Zhang et al., 2019). After the collection is full, as long as the mesh liner is removed and replaced, it can continue to work. The structure is simple and easy to operate, but it requires constant use of energy to maintain the liquid level difference, which can cause unnecessary energy loss when the water surface is relatively clean.

#### **Product Function Analysis**

As a typical aquatic plant management equipment, the river grass cleaning machine mainly functions in the following aspects:

##### ***Underwater propulsion function***

The propulsion function in water is mainly divided into three types: spiral propulsion, wheel propulsion, and air spiral propulsion. The main form of spiral propulsion is a propeller, which is generally installed at the rear of the ship and submerged in the water, with high efficiency but the disadvantage of insufficient lift. The main form of wheel propulsion is to push the machine forward by pulling water from the blades on top of the wheel when it enters the water. It is commonly used in inland river areas and has flexible installation, but it is relatively cumbersome. Air spiral propulsion is mainly driven by compressed air, with sufficient raw materials and environmental protection, but high requirements for implementation.

##### ***Operation method***

According to research and analysis, the water grass harvesting boat has gone from being operated by 2-4 people, to being operated by a single person, and then fully automated. The space originally used as a cockpit has become smaller and even completely abandoned. Therefore, weakening the operation cabin and leaving more space for the storage cabin is the direction of consideration in this design. We plan to adopt unmanned operation based on artificial intelligence technology to reduce labor loss and improve efficiency.

##### ***Cutting and crushing function***

This is a common main function of aquatic plant cleaning devices. According to the working mode of cutting devices, there are mainly reciprocating and rotary cutting methods. Reciprocating type usually has two blades, which cut each other through one or two common reciprocating movements. When rotating, it is usually equipped with a rotating shaft, and then 3-4 blades are installed on the rotating shaft. The blades are driven to rotate around the shaft to complete the cutting of water plants.

##### ***Transport function***

When the distance between the front-end harvesting device and the internal storage device is too far, equipment such as conveyor belts or robotic arms are often used as assistance to ensure the continuity of harvesting work.

##### ***Loading and collection function***



In order to avoid secondary pollution to the ecological environment of the water area, the water grass harvester needs to be equipped with a water grass collection and storage device to timely salvage the cut water grass (Zou et al., 2018). An efficient aquatic plant cleaning equipment, in order to avoid frequent communication between the water banks, is necessary to have its own storage space. However, a large amount of storage space often sacrifices the overall size and flexibility of the equipment. Large capacity water plant harvesting devices generally use fixed box type storage bins, which are bulky and bulky in shape. Compared to large equipment, small and medium-sized equipment requires higher flexibility of the body to complete operations in more complex small water areas.

#### **Product Styling Analysis**

The design of aquatic plant management products is based on their function and structure. Due to the fact that the main working environment of the equipment is working on water, the common design is mainly based on ships, with a focus on

functional use. The design of the appearance is often weakened, with strong engineering characteristics. The main body of this type of product is a sharp metal shell, with many structures directly exposed to the outside. The front end of the water grass collection device is often a large cutting blade or conveyor belt. Visually leave a complex and cumbersome impression. Table 1 presents the author's summary and analysis of three common aquatic plant management devices in China, including their product design characteristics, working principles, and limitations, to help understand the coordination between their functions and design.

Table 1: Comparative analysis of three small and medium-sized aquatic plant management products on the market.

	Combination of ordinary hull and harvesting equipment	Water integrated equipment	Medium to large amphibious products
Appearance			
Characteristic	The overall structure is composed of simple mechanical components combined with a regular hull, with a simple shape and a single color.	Part of the mechanical structure is exposed, and the fuselage mostly adopts straight lines. The fusion between the cutting device and the body is poor.	Most of the fuselage adopts straight lines, with a rounded overall treatment.
Working methods	Ordinary hull combination cutting, conveying devices, etc. According to different job requirements, functional accessories such as grab buckets and digging arms have also been developed.	Can achieve semi-automatic work, with fixed operations and storage areas, and return to the shore for unloading when a certain storage capacity is reached.	Through tracks, it can move freely in water and on the ground, reaching a certain storage capacity and being transported to designated locations.
limitations	Limited operating space and storage space, low efficiency, and potential health issues for operators.	This type of method is more suitable for relatively wide areas, and will no longer be applicable for some complex and shallow water areas in the watershed.	To provide amphibious power, track structures occupy a large volume.

## CONCEPTUAL DESIGN POSITIONING OF INTELLIGENT PRODUCTS FOR RIVER AQUATIC PLANT MANAGEMENT

### Design Concept Proposal

Through background analysis, the design direction for river aquatic plant management products has gradually become clear, which is to combine modern intelligent technology to carry out a conceptual design of a river aquatic plant management product with novel design, comprehensive functions, flexible operation, and efficient work.

Conceptual design, as a common design method for developing innovative products in industrial design, is manifested in the continuous evolution process of design concepts from coarse to fine, from fuzzy to clear, and from abstract to concrete. Through conceptual design, abstract requirements are concretized to form functional solutions that meet the requirements, principle solutions for implementing functions, and even modeling solutions that conform to the principles. The creative and pioneering design thinking of conceptual design is very suitable for the design and development content of this project (Jia, 2014).

### Positioning

#### Positioning of Product Governance Objects and Application Scenarios

This project will use small and medium-sized water bodies such as inland rivers as application scenarios for this concept product, especially in shallow water areas at the end that are prone to accumulation of water plants. The main target of governance is floating aquatic plants such as water hyacinths, which are common in freshwater rivers.

**Product Function Analysis and Positioning**

Using the method of combining mind mapping and classification induction, analyze and discuss the functions of the product, as shown in Figure 1. Through analysis, seven basic functions of the aquatic plant management product design in this river channel were identified, including amphibious function, cutting and crushing function, loading and collection function, full load alarm function, energy and power support, collision prevention function, and monitoring and identification function.

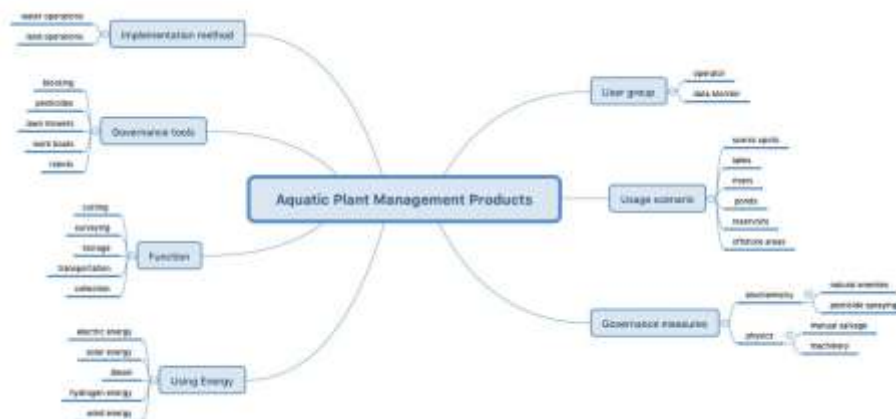

Figure 1: Design theme mind map.

**Shape analysis and positioning**

According to product market research and styling analysis, it can be seen that traditional aquatic plant management equipment has a design status of emphasizing function over appearance. Therefore, the product styling design should be innovative in terms of styling while combining product functions, breaking the styling constraints of traditional cleaning equipment on the market, changing the visual perception of "manually driven box iron boats", and reducing the cold and hard feeling caused by excessive engineering. Combining streamlined design styles with technological lines, it is also possible to refer to the biomimetic design of some aquatic or other organisms. At the same time, breaking the thinking limitations of ship work and attempting to diverge towards the "non ship" direction.

**DESIGN PROCESS**

**Preliminary Expression of Design Concepts and Feasibility Plan Design**

After clarifying the design concept and direction, based on this, a brainstorming method is used to express the design method that meets the design requirements and positioning in the form of product sketches, as shown in Figure 2.



Figure 2: Preliminary product sketch plan for design.

Based on design concepts and positioning, brainstorm to express product solutions that meet design requirements and positioning in the form of product sketches. And through the organization and analysis of sketch schemes, three feasible schemes that align with the design concept positioning are proposed, as shown in Figure 3.



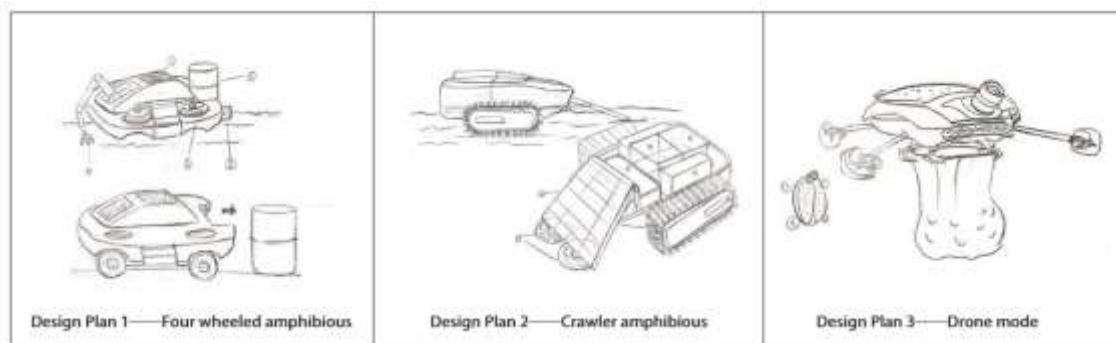

Figure 3: Three conceptual design schemes.

The first product design scheme adopts the concept of amphibious land and water. This design installs deformable amphibious tires on traditional ship hulls. The front is picked up by a mechanical gripper and placed in a central empty storage bin, which is then sent to a detachable processing bin in the rear for a series of crushing and compression. After being fully loaded, it can be unloaded and replaced on shore. Product Design Plan 2 is a tracked amphibious aquatic plant management product. Its working principle is that when working in water, the track moves the water to generate forward power. At the forefront of the machine is a rotating cutting blade that cuts suitable heights of aquatic plants. The conveyor belt transports the cut aquatic plants to a temporary storage location, then to the drainage and drying section, and finally crushes them into a fixed shape for storage. When the cleaning reaches a certain amount, the ship's draft reaches the control line, and the machine automatically lands, transporting the cleaned aquatic plants to the designated location for unloading, completing a series of work processes.

The first two design schemes mainly focus on amphibious operations, with a smaller breakthrough in styling design compared to existing products. Therefore, in the third design scheme, combining the latest technological achievements of drone technology and artificial intelligence technology, a water air amphibious concept aquatic plant management product is designed. This design scheme utilizes the design methods of bionics and product semantics, and the overall shape has a strong sense of technology. Based on the main body of the bionic shell, combined with functional positioning, local shape planning is carried out. The inspiration for the product design comes from herbivorous insects. Through abstracted biomimetic simulations of their feeding habits and appearance, elements of insect mouthparts, shells, and wings have been extracted, evolving into an entrance for collecting aquatic plants, as well as a product shell and solar charging panel. Create an image of a grass like natural enemy for aquatic plant cleaning equipment, both visually and functionally.

#### Optimization of Design Scheme and Establishment of Final Scheme

After discussion and analysis, it is believed that the third design scheme has high innovation in both product functionality and styling. Therefore, in-depth design optimization was carried out on the design scheme from appearance to structure. In terms of appearance design, the product features a highly abstract and refined "beetle" design, making it more in line with the design characteristics of flight products. Figure 4 shows the process of further refining and optimizing the appearance of the preliminary design scheme. In terms of internal working principles and structure, the rationalization of internal structure has been improved. The optimal design scheme for the product design was ultimately determined.

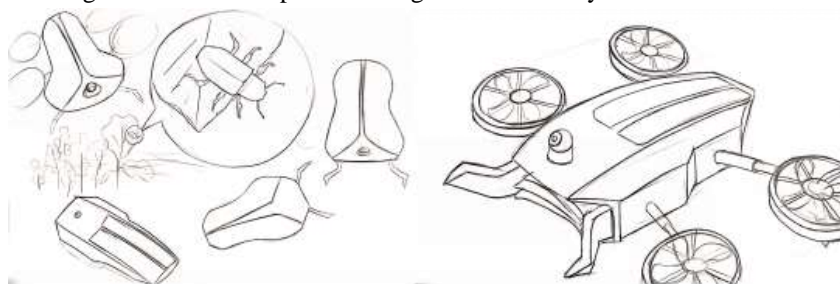

Figure 4: Product design optimization and improvement.

Establish a 3D model of the final design plan through rhinoceros software, specifying the size of each part of the product. Figure 5 shows the 3D modeling display of the final product design and styling scheme. The final product size is determined to be an overall body length of 2.5 meters, a body width of 3 meters, and an overall height of 1.6 meters. Figure 6 is a dimensional diagram of the product.



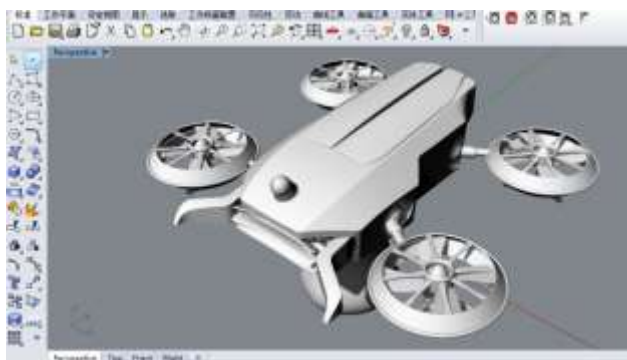

Figure 5: Final product design scheme 3D model.

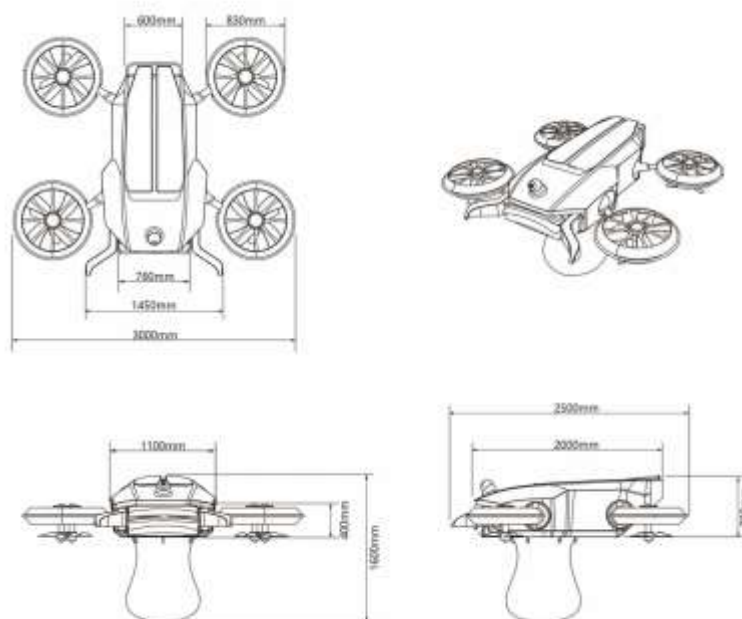

Figure 6: The dimensional diagram of the product.

### Product Structure Design and Functional Design

Based on the preliminary product functional analysis and combined with the product design, the internal structure is designed reasonably, as shown in Figure 7. The internal structure of the product mainly includes the main intelligent control terminal, bevel gear, water pump, battery, solar panel work box, drive motor, connecting shaft, etc. The main intelligent control terminal mainly controls the survey, route planning, return navigation of the detection device, as well as the mode switching of the driving device and the reminder of the body's full load. The two ends of the conveyor belt are respectively connected to the blades of the cutting device and the driving motor, and the bevel gear connecting shaft in the middle of the conveyor belt controls the rotation of the water pump through the bevel gear. During the process of cutting water plants with the blade, the driven water pump simultaneously moves to pump the water plants that have been cut into the interior into the collection net bag below the body. The solar panel work box and battery mainly convert the solar energy collected on the solar charging panel into electrical energy and store it. The other end of the drive motor is also connected to the water air flow stream tire body to control its rotation and mode switching.

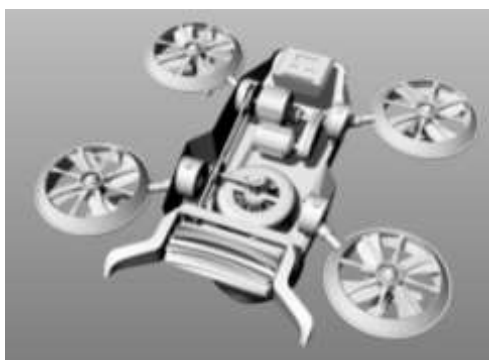

Figure 7: Product internal structure design.

Figure 8 is a structural explosion diagram of the final established product design scheme, indicating all components of the fuselage. The overall structure of this product includes detection components, cutting components, water pumps for collecting harvested aquatic plants into mesh bags, main control terminals, driving components, battery power supply components, and water air wheel components. Each component works together to complete a series of workflows.

The concept design of this aquatic plant management product has a total of 7 product functions, including water and air amphibious function, cutting and crushing function, loading and collection function, full load alarm function, new energy drive, monitoring and positioning function, and collision protection function. Table 1 provides a summary of product functions and corresponding component introductions.



Figure 8: Explosion diagram of product structure.

The concept design of this aquatic plant management product has a total of 7 product functions, including water and air amphibious function, cutting and crushing function, loading and collection function, full load alarm function, new energy drive, monitoring and positioning function, and collision protection function. Table 2 provides a summary of product functions and pictures of corresponding component. Below is a specific introduction to the functions of each part one by one.

**Water air amphibious function**

The implementation of this function mainly relies on the amphibious quadcopter structure configured at the edge of the equipment, with each unit equipped with two spiral devices, one large and one small, on the same central axis. The four slightly larger ones are spiral wings used to control air navigation, while the smaller ones are propellers responsible for underwater propulsion. The quadcopter structure can switch horizontally and vertically according to different working states. When driving in the water, the four units are perpendicular to the water surface, and the slightly smaller propeller behind undulates the water surface. When switching from water surface to air navigation, the structure switches to be parallel to the fuselage, leaving a certain distance between the spiral wing and the water surface to ensure normal air propulsion and underwater takeoff.

**Cutting and crushing function**

This product adopts a single axis multi-blade rotary cutting method similar to the front end of agricultural harvesters, which facilitates the automatic insertion of cut debris into the machine with the movement of the blades, integrating cutting and transmission. The cutting function of this device is mainly achieved by the rotating cutting blade structure placed at the forefront, where the movement of the blade pulls in the chopped water grass and transports it to the inside of the machine. The external expansion of the collection port simulates the appearance of insect mouthparts, simulating insect feeding while better collecting the water plants in front into the cutting port.

**Loading and collection function**

A replaceable filter screen is installed at the bottom of the equipment, as shown in the figure. The filter screen port is connected to the inside of the machine, and the water grass that has been cut and treated in the front passes through the water pump inside the machine, and is temporarily discharged and stored in this net pocket. Due to the softness and elasticity of the net pocket, it can be easily collected even in shallow water areas. When the machine reaches full load, it returns with a net bag and automatically packs and unloads it, replacing it with a new storage module.

**Full load alarm function**

In response to the operation of the machine collecting in water, in order to prevent flooding or other possible faults caused by overload, a draft sensing device is added to the equipment casing. When the water surface does not reach the position corresponding to the calculated maximum load, the value is directly reflected in the control center to remind the equipment to return for unloading.

**Energy and power analysis**

Traditional diesel generators not only generate high noise but also emit high carbon emissions during combustion, which is not in line with the concept of sustainable development. Moreover, once an oil leak occurs in the water, it can cause secondary pollution to the local water surface and is extremely difficult to clean. Based on the concept of energy conservation, environmental protection, and reducing carbon emissions, electric drive is a more friendly choice. In addition, combined with the solar charging panel on the top of the device, the electrical energy is stored in the battery, making reasonable use of renewable energy.











**Monitoring and identification function**

Install infrared remote sensing recognition function above this product to detect the density of water plant growth during flight patrols over water areas, quickly and accurately locate the types of water plants that need to be cleaned, and with the support of GPS navigation and big data algorithms, it can automatically plan the optimal harvesting path.

**Collision prevention function**

Unmanned operation often encounters some uncontrollable faults. In order to reduce the possibility of accidental collisions during water navigation and air flight, collision prevention devices can be added to the edge of the machine.

Table 2: Introduction to product functions and corresponding components.

Pictures & Discription	 Propeller underwater working mode	 Propeller air working mode	 Aquatic plant cutting blade	 Collection port
Fuction	Water air amphibious		Cutting and crushing	
Pictures & Discription	 Propeller underwater working mode	 Propeller air working mode		
Fuction	Loading Collection		Full load alarm / New energy driven	
Pictures & Discription	 Infrared remote sensing camera	 Anti-collision strip	X	
Fuction	Monitoring and positioning / Collision prevention			

The design scheme of this water air amphibious concept aquatic plant management product operates on the principle of using drone technology as the main body of the body. During aerial operations, four propellers drive the product to fly. Combined with artificial intelligence technology, the detection device on the body perceives the distribution area of aquatic plants, plans

cleaning routes, and guides the body to fly to designated water areas for operation. When working in the water, the four propellers turn to serve as propulsion for the fuselage, maintaining its ability to work on the surface of the water. The collected aquatic plants of this product are compressed and placed in a unified storage area. After reaching a certain storage capacity, the four wing conversion drives the body to fly to the predetermined unloading area. After unloading is completed, the product returns to the river channel to continue cleaning work. All work processes are set up in advance by the computer and completed independently by the machine in combination with artificial intelligence. Figure 9 shows the workflow diagram of the product.

### Product Color Scheme Design

The appearance of the product mainly includes two aspects: color and form. Regarding color, traditional machinery mostly gives people a feeling of gray and cold (Xie, 2022). In today's society where the product market is extremely rich and fiercely competitive, designers have begun to value the "vitality" that machines bring to people's lives.

Through preliminary research and analysis of mechanical color language, we ultimately adopted milky white as the main color of the product, paired with black solar panels on the body. The four-wheel body wings are equipped with warning orange collision strips. The water plant processor in the front section of the body and the connecting parts of the body are all dark gray. Based on the simple, generous, rational, and rigorous color matching concept, the design of this color scheme breaks away from the color scheme of similar products mainly featuring blue and green heavy industrial colors, allowing river aquatic plant management products to be presented to the public with a new technological and intelligent appearance. The final color scheme design and color matching instructions of the product are shown in Figure 10.

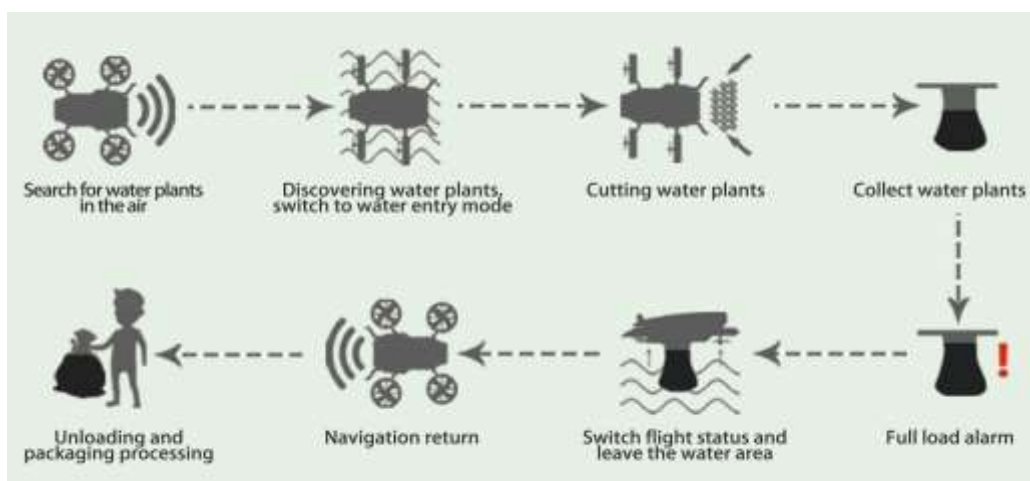

Figure 9: Working-flow design.

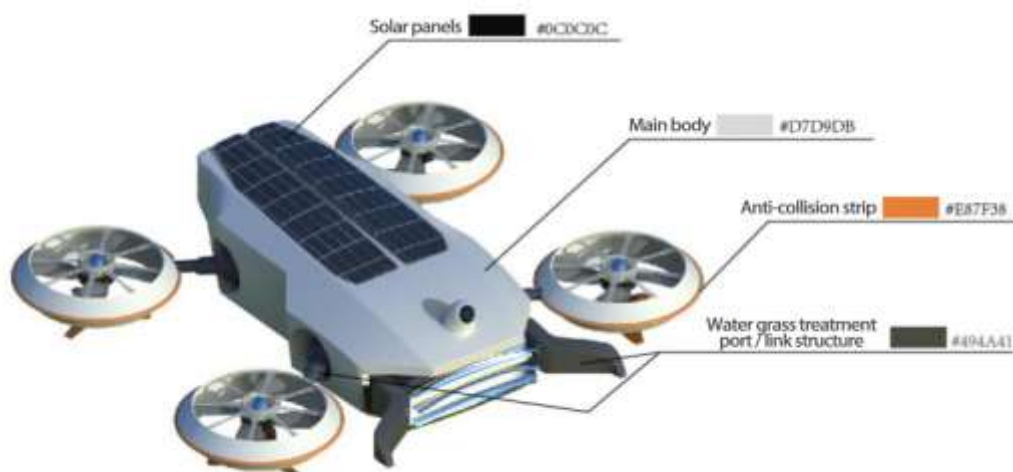

Figure 10: Final color scheme description.

### Product Application Scenario Display

Figure 11 shows the operational status of the product during aerial patrol surveys, as well as the cleaning of water plants in the water, including the storage status of the product after cutting the water plants underwater.





Figure 11: Product application scenario rendering display.

### CONCLUSION

Through the research of this topic, we have gained a deeper understanding of aquatic plant cleaning equipment. People's attention to the development of this field reflects not only scientific and technological exploration, but also reflection on the deterioration of the aquatic environment. Being able to utilize existing technology to keep the water clean is the greatest significance of this type of product at present, and it is also an attitude exhibited by humans to nature. It can be said that the research results of this project point out the direction for product design and development in the current river aquatic plant management industry. Of course, this design also has certain limitations, as the product design scheme is a conceptual design, and the implementation of its functional design still requires rigorous scientific and market validation.

Society is developing rapidly, solving some old problems left over by history, but new problems will also emerge endlessly. The development and progress of technology are sails raised in the pursuit of problem-solving, so various cutting-edge, innovative, and breakthrough conceptual designs are the rudder in control. The research of this project aims to provide a new direction for improving the aquatic environment, and hopes to be truly realized in the near future.

### ACKNOWLEDGMENT

This work was sponsored by the Major project of Philosophy and Social Science research in colleges and universities of Jiangsu Province (2023SJZD108), Nanjing Institute of Technology university-level scientific research innovation fund project (CKJB202211).

### REFERENCES

- Zhang, J. Y. (2017). The Mechanism and Control Technology of Huber Eutrophication and Its Application Shandong Industrial Technology (13), 244.
- Zhao, Y. H., Li, T., Huang, B., Feng, Y.L., Lei, M.J, Zhuo, H.H, & Wu Y.L. (2022). Characteristics and driving factors of water quality and eutrophication evolution in typical lakes in the middle reaches of the Yangtze River from 2016 to 2020 Lake Science (05), 1441-1451 (in Chinese).
- Liu, J. Y., Zhou, X. C. (2021). Review of Application Research on Aquatic Plant Remediation of Eutrophic Water Bodies Modern Horticulture (03), 51-52. <https://doi.org/10.14051/j.cnki.xdyy.2021.03.020> (in Chinese).
- Zhang, S. (2020). Application of aquatic plants in urban river management projects Modern Horticulture (24), 107-108. <https://doi.org/10.14051/j.cnki.xdyy.2020.24.051> (in Chinese).
- Wang, D. D. (2016). Research on the Mechanism Design and Cutting Device of a Water Gourd Double Layer Cutting and Collecting Ship (Master's Thesis, Shanghai University of Engineering and Technology) <https://kns.cnki.net/KCMS/detail/detail.aspx?dbname=CMFD201701&filename=1016159459.nh> (in Chinese).
- Bian, H. Q. (2016). Design and Research of a Deformable Amphibious Cleaning Ship Based on Parallel Mechanisms (Master's Thesis, Shanghai University of Engineering and Technology) <https://kns.cnki.net/KCMS/detail/detail.aspx?dbname=CMFD201701&filename=1016159426.nh> (in Chinese).
- Xu, Y. (2019). Design and Experimental Research on the Cutting Conveying Feeding System of Amphibious Water Grass Harvester (Master's Thesis, Jiangsu University) <https://kns.cnki.net/KCMS/detail/detail.aspx?dbname=CMFD202001&filename=1020600686.nh> (in Chinese).
- Hu, Z. Y., Tang C. Q. (2022). Reflections and Prospects on the Integration of Artificial Intelligence Technology into the Design Discipline in the New Era Design (04), 84-86 (in Chinese).
- Zhang, R., Wang, Y., & Qiu, S. (2019). Design of a semi-automatic infiltration type water waste collection system Art and Technology (08), 70-73 (in Chinese).
- Zou, Z. X., Wang, Z.N., Huang, Z. K. & Wang, H. X. (2018). Application and Development of Water Grass Harvester in Different Water Environment Mechanical Engineering and Automation (06), 217-219 (in Chinese).
- Jia, Z. (2014). Analysis of Product Conceptual Design Concepts and Methods Popular Literature and Art (21), 110-111 (in Chinese).
- Xie, H. Q. (2022). Research on the Application of Industrial Design in Intelligent Home Appliance Product Design China Equipment Engineering (16), 31-33 (in Chinese).

## Research on the Influence of Recommended Online Testing and Evaluation on College Students' Purchase Intention of Beauty Products

Yingzhi Guo<sup>1,\*</sup>  
Yongzhong Yang<sup>2,\*</sup>  
Kunming Luo<sup>3</sup>

\*Corresponding author

<sup>1</sup> Master Student, Sichuan University, Chengdu, China, 2448414256@qq.com

<sup>2</sup> Professor, Sichuan University, Chengdu, China, yangyongzhong116@163.com

<sup>3</sup> Doctoral Student, City University of Macau, Macau, China, 249932573@qq.com

### ABSTRACT

With the popularization of Internet technology and the rise of social platforms, the consumption scenario of beauty products has gradually shifted from offline to online. However, as an important source of pre-purchase decision-making information for college students, the online testing and evaluation (OTE) of beauty products has not attracted much attention from the scholars. Based on this background, our study innovatively considers the trend of decentralization and establishes a model to explore the impact of recommended OTE on college students' purchase intention regarding beauty products. The results are as follows: (1) Except for visual cues, the professionalism, popularity and content quality all have significant positive effects on purchase intention; (2) Perceived risk plays a mediating role between the above three variables and purchase intention; (3) Perceived functional value plays a mediating role between popularity, content quality and purchase intention. Finally, we put forward suggestions for the OTE operators to improve consumers' purchase intention, and also hope to help college students make rational purchase decisions.

*Keywords:* Online testing and evaluation, perceived risk, perceived functional value, purchase intention.

### INTRODUCTION

American management scientist Herbert Simon mentioned in his book "The New Science of Management Decision" that information technology is the basis of decision-making and has an important impact on the economy. The Internet, as the most popular information technology in the 21st century, enables users to obtain and share information in real time, which further makes decentralization possible. The concept of "decentralization" was first proposed by American scholar Mark Post in 1990. He later pointed out in his book "The Second Media Age" that the focus of decentralization should shift from the dissolution of self-consciousness to the change of communication mode, and the new information subject adapted to the new cultural context is dissociative, decentralized and deauthoritative. Specifically, decentralization can be understood as meaning that the production of network content is no longer controlled by professional institutions or specific groups of people, but is jointly participated and co-created by all netizens with equal power. Under the trend of decentralization, everyone in the network communication process can become a node. Each node is highly autonomous and has the potential to become the center, but does not have the mandatory central control function. Nowadays, the mode that opinion leaders and ordinary netizens disseminate information through social platforms such as Facebook, Twitter and Tiktok is a typical example of decentralization.

According to data released by the National Bureau of Statistics, the total retail sales of beauty products in China will reach 393.6 billion yuan in 2022. Although mature women are still the main force, in recent years, consumer group of beauty products has gradually tilted towards young women, especially campus women. At the same time, public data shows that the economics of male beauty is rising. Whether it is for social or aesthetic needs, male college students have the possibility of becoming an emerging consumer group in the beauty market. It is not difficult to find that college students have become one of the major consumer groups with great development potential. Through the observation of college students' daily life scenes and the pre-survey interviews, we found that the consumption of beauty products is one of the main expenditure components of college students' online shopping, and college students prefer to refer to OTE to obtain information about beauty products. An important reason for this phenomenon is the limited economic conditions of college students and the diversity of beauty products. The OTE of beauty products can precisely enable college students to have a relatively complete understanding of multiple beauty products at almost no economic cost. Besides, they can also refer to the opinions of other netizens.

After reading and sorting out the relevant literature, we believe that this study has two main innovation points and the necessity of research. First, most of the current researches on "Internet + beauty products" at home and abroad focus on live streaming and short video marketing. Few studies have in-depth analysis of OTE of beauty products which is emerging. However, in reality, the quality and effect of OTE are uneven, which not only makes it difficult for operators to find scientific ways to improve purchase intention from the perspective of consumers, but also fails to help college students make satisfactory

decisions. Therefore, the conclusion of this study has strong practical significance for both OTE operators and college students. Second, most scholars only study the opinion leaders, ignoring the increasingly important role that ordinary people play in Internet information dissemination. Under the trend of decentralization, every netizen has the opportunity to become an independent information sharing center. Therefore, our research on the subjects of OTE should not only be limited to opinion leaders, but also include ordinary people in the research scope.

Adopting the paradigm of empirical research, this study aims to explore the influencing factors of recommended OTE on college students' purchase intention of beauty products. We divide OTE into two facets: the characteristics of subject (professionalism and popularity) and the characteristics of information (content quality and visual cues). Taking the above four dimensions as independent variables and adding perceived risk and perceived functional value as intermediary variables, we constructed a model of college students' purchase intention of beauty products. Finally, based on the conclusions obtained from data analysis using structural equation modeling, we propose management implications for OTE operators and college students respectively.

## LITERATURE REVIEWS AND RESEARCH HYPOTHESIS

### Online Testing and Evaluation (OTE)

Online testing and evaluation is essentially a type of user-generated content. After using the product, the users spontaneously conduct a comprehensive analysis of the product's appearance design, efficacy, price, ingredient safety and other dimensions. And then they present the testing process and personal evaluation in the form of text posts or videos for the purpose of experience sharing or product promotion. User-generated content such as OTE is essentially educational and can affect consumers' cognition (Choi & Behm-Morawitz, 2017). Therefore, companies such as L'Oreal are increasingly recognizing the value of user-generated content, even investing money to encourage users to share tutorials and experiences in the beauty community.

It is worth mentioning that since scholars have not reached a consensus on the concept of OTE, some people may question the similarity between "OTE" and "unboxing". Therefore, it is necessary to clarify the difference between these two concepts. In the field of e-commerce, unboxing generally refers to the process of unpacking a product recorded by users through videos and other methods (Marsh, 2016). These videos usually include detailed introductions to the appearance, functions and usage of the product, and may even be told as a unique consumption story (Kleut et al., 2018). However, unpacking mainly conveys emotional value, vicarious experience and preliminary product information to consumers, and it does not require in-depth exploration and evaluation of the product (Vaudrey, 2022). On the contrary, presenting the test and evaluation to consumers after using the product for a period of time is a potential requirement for OTE of beauty products.

At present, there is no generally accepted definition of the term "online testing and evaluation". But under the trend of information networking and economic globalization, netizens at home and abroad have a certain degree of common understanding of it. In this study, OTE refers to the testing and evaluation of beauty products displayed by any netizen through Internet channels. There are three common categories of OTE: recommendation type, dissuasion type and comparison type. We choose the recommended type for research. In common situations, the OTE is generally presented in the form of video or post to transmit and share information through domestic and foreign mainstream social platforms such as Tiktok, YouTube, and Twitter.

Combining previous research and the reality of OTE, we divide it into two facets: the subject and the information. The subject, that is, the person who evaluates beauty products and interprets the results, can be studied from the dimensions of professionalism and popularity. Professionalism can be measured by knowledge, ability and experience (Netemeyer & Bearden, 1992). Drawing on the popularity scale developed by Meng (2012), we measure popularity from three dimensions: social status, public familiarity and celebrity effect. Information, that is, the content that audiences can watch and listen to on mobile devices and the way it is presented, can be divided into two dimensions: content quality and visual cues. Referring to the scale of Shen, Guo and Li (2013), we use authenticity, objectivity and usefulness as indicators to measure content quality. Visual cues can be measured by readability, richness, and intuitiveness (Meng, 2012).

### Purchase Intention

Purchase intention refers to the possibility and subjective tendency of consumers to make a purchase decision, which is often used to predict actual consumption behavior (Mullet & Karson, 1985). Many scholars believe that purchase intention is the psychological tendency of customers to make purchase decisions after they collect information to understand products and make value judgments in the early stage. Therefore, purchase intention can usually be used to predict purchase behavior (Dodds, Monroe, & Grewal, 1991). Based on the research results of Zeithaml, Parasuraman and Malhotra (2002) and the reality of online shopping, we measured the purchase intention from four aspects: purchase impulse, priority, repurchase and recommendation to others.

Regarding the characteristics of OTE subjects, some studies show that consumers' purchase intention is more likely to be influenced by the opinions of experts than non-experts (Bansal & Voyer, 2000). That is, professionalism may have a positive impact on purchase intention. Popularity reflects the degree to which the subject is loved, sought after or trusted by the masses. Consumers may regard the opinions of famous people as reliable sources of information (Till, 1998), so they are more willing



to follow their choices and enhance their purchase intention (Meng, 2012). Regarding the characteristics of OTE information, Davis and Khazanchi (2008) defined visual cues as any image-related communication means used to enable consumers to get visual sensory stimulation, which can positively affect consumers' cognition and purchase intention. In addition, as a source of information, the content quality is the persuasiveness implied in the information (Bhattacharjee & Sanford, 2006), which can positively influence consumers' purchase intention (Gomes, Marques, & Dias, 2022). Therefore, we propose the following hypothesis:

- H1: Professionalism has a significant positive impact on purchase intention.
- H2: Popularity has a significant positive impact on purchase intention.
- H3: Content quality has a significant positive impact on purchase intention.
- H4: Visual cues have a significant positive impact on purchase intention.

### **Perceived Risk**

The concept of perceived risk was first expressed by American scholar Bauer (1960) as that consumers cannot accurately predict the correctness of the results when making purchase decisions, and the unexpected results may not bring consumers satisfaction. In the nearly sixty years of research on perceived risk, scholars have different views on the dimension division of perceived risk. Kaplan, Szybillo and Jacoby (1974) argued that perceived risk can be divided into five dimensions: financial risk, functional risk, physical risk, psychosocial risk and social risk. Stone and Grønhaug (1993) proved that perceived risk can be divided into six dimensions: financial, performance, physical, psychological, social and temporal. Some scholars developed a scale of perceived risk for online shopping and identified three dimensions of financial risk, product risk and time risk (Forsythe et al., 2016). Combined with previous research results, our study selected financial risk, functional risk, time risk and psychological risk to measure perceived risk.

Some scholars have proved that the popularity and expertise of opinion leaders are important dimensions to reduce risk perception of products, and positively affect purchase intention through the mediating role of perceived risk (Biswas, Biswas, & Das, 2006). Chen, Tsai and Lin (2017) has proved that high-quality positive information delivered by opinion leaders can inhibit consumers' perception of risk, and perceived risk has a negative impact on purchase intention. In addition, Pahlevan Sharif and Mura (2019) demonstrated that perceived risk plays a mediating role in the positive impact of information characteristics of user-generated content on purchase intention. Therefore, we propose the following hypothesis:

- H5a: Professionalism has a significant negative impact on perceived risk.
- H5b: Popularity has a significant negative impact on perceived risk.
- H5c: Content quality has a significant negative impact on perceived risk.
- H5d: Visual cues have a significant negative impact on perceived risk.
- H6: Perceived risk has a significant negative impact on purchase intention.
- H7a: Perceived risk plays a mediating role between professionalism and purchase intention.
- H7b: Perceived risk plays a mediating role between popularity and purchase intention.
- H7c: Perceived risk plays an intermediary role between content quality and purchase intention.
- H7d: Perceived risk plays a mediating role between visual cues and purchase intention.

### **Perceived Functional Value**

Perceived value is the subjective utility evaluation generated by consumers after comprehensively evaluating the perceived profit and loss of a product or service (Zeithaml, 1988). Sheth, Newman and Gross (1991) systematically proposed five dimensions of perceived value: functional value, emotional value, conditional value, social value and cognitive value. However, the academic community has not reached a consensus on the dimensions division of perceived value. With the emergence of more and more consumption situations, the driving factors and dimensions of perceived value should have different interpretations. According to Simová and Cinkánová (2016), three of the six perceived value that consumers are most concerned about belong to functional factors. Combined with our research, consumers will pay more attention to the acquisition of functional value when watching the OTE of beauty products. These perceived functional values are consumers' comprehensive evaluation of product or service attributes, which can be measured by three aspects: efficacy, practicality, and compliance with expectations (Sweeney & Soutar, 2001).

Pan (2023) pointed out in her research that the higher the professionalism and popularity of anchors, the more consumers perceive the functional value, and thus increase their purchase intention. Wang (2020) conducted a comprehensive study on the mediating role of perceived functional value between information characteristics and purchase intention. Her research results show that the quality and presentation of information can help enhance consumers' perception of functional value, and play a positive impact on purchase intention through the mediation role of perceived functional value. In addition, some scholars have proved that perceived functional value will have a positive impact on consumers' purchase intention of beauty products (Bae, Kim, & Oh, 2019). Therefore, we can propose the following hypothesis:

- H8a: Professionalism has a significant positive impact on perceived functional value.
- H8b: Popularity has a significant positive impact on perceived functional value.
- H8c: Content quality has a significant positive impact on perceived functional value.

- H8d: Visual cues have a significant positive impact on perceived functional value.
- H9: Perceived functional value has a significant positive impact on purchase intention.
- H10a: Perceived functional value plays a mediating role between professionalism and purchase intention.
- H10b: Perceived functional value plays a mediating role between popularity and purchase intention.
- H10c: Perceived functional value plays a mediating role between content quality and purchase intention.
- H10d: Perceived functional value plays a mediating role between visual cues and purchase intention.

Now, we can propose the theoretical model of this study, which is shown in Figure 1.

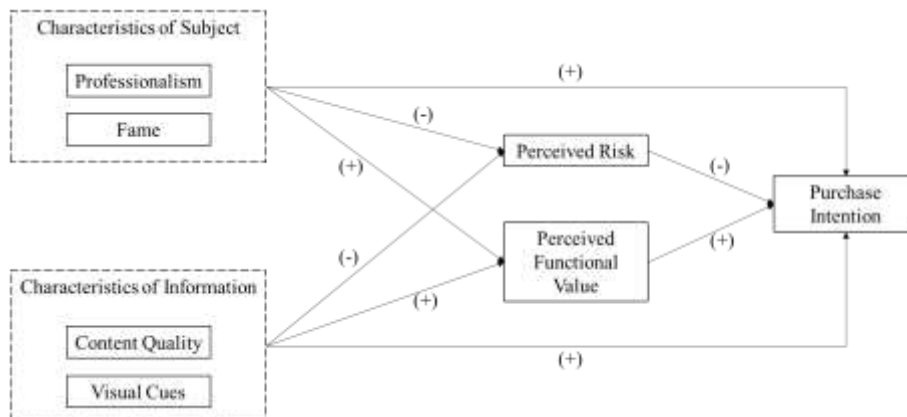

Figure 1: Theoretical Model

### RESEARCH DESIGN AND EMPIRICAL ANALYSIS

#### Research Design

This study adopts the method of questionnaire survey. After collecting and sorting out the literature, we drew on the mature scale of relevant variables measurement in the existing studies, and made appropriate modifications to the wording and statements of the scales according to the objective reality of the OTE. The questionnaire was presented in the form of a Likert 5-level scale. The respondents were asked to recall a specific experience of referring to OTE, and rated the degree of agreement with each option according to their real thoughts. In order to ensure the good reliability and validity of the questionnaire, we conducted three small pre-tests, and repeatedly modified or deleted unreasonable items in the questionnaire, and finally obtained 29 items.

#### Data Collection

The research objects of this study are college students who have a certain understanding or reference experience of OTE. We used the applet Questionnaire Star to edit the questionnaire, and distributed the pre-survey questionnaire to WeChat Moments and college students' communication groups across the country. After analyzing the reliability of pre-survey data, we modified and adjusted the questionnaire three times. The last pre-survey questionnaire achieved high reliability and validity and could be used for further analysis. We distributed questionnaires again through similar channels. Then we integrated the questionnaire data of pre-survey and formal survey, and finally obtained 390 questionnaires. One of the questionnaires was not filled out by college students, and the answers of the two questionnaires were repeated too much. After excluding invalid questionnaires, a total of 387 valid questionnaires were collected. Subsequently, SPSS Statistics 26 and AMOS 23.0 were used to analyze the sample data of the valid questionnaires.

#### Descriptive Statistical Analysis

Gender, age and income in the first part of our questionnaire are a survey of demographic variable information. Frequency analysis is used to make a preliminary summary of the above demographic information to understand the basic situation of the respondents.

As can be seen from Table 1, the male to female ratio of the respondents is 7:3. Although the consumer group of beauty products is still dominated by women, the demand of men for beauty products is becoming increasingly prominent, which illustrates the economics of male beauty has great potential. The age distribution of the respondents is mainly concentrated between 18 and 25 years old, that is, undergraduates and master students are the majority, accounting for 74.9%. In addition, we can also learn that the respondents with an average monthly living expenses of less than 2000 yuan are the most, nearly half of the total number. We speculate that the behavior of choosing beauty products by referring to OTE may be related to income.

Table 1: Descriptive Statistical Analysis

Basic Features	Classification	Frequency	Proportion
Gender	Male	116	30.00%
	Female	271	70.00%

Age	18~25	290	74.90%
	26~30	97	25.10%
Income	0-2000 yuan	178	45.99%
	2001-3000 yuan	133	34.37%
	3001- 5000 yuan	75	19.38%
	More than 5000 yuan	1	0.26%

Source: This study.

### Reliability and Validity Test

The purpose of reliability analysis is to study the reliability of measurement results and explore whether there is internal consistency in these measurement results. As can be seen from Table 2, the CITC values of all items are greater than 0.5, indicating that the item settings are relatively reasonable. Cronbach's  $\alpha$  of all variables is greater than 0.7, indicating good internal reliability of the scale.

Validity refers to the accuracy of the measurement results in reflecting the measurement objectives. From Table 2, it can be seen that the KMO values of all variables are greater than 0.7, and the combined reliability is greater than 0.7, indicating that the data of this scale has high convergent validity.

The bold values of the diagonal lines in Table 3 are the square root values of AVE, and the data located at the bottom left of them are the correlation coefficients between variables. The AVE square root values of each variable is greater than their corresponding correlation coefficient in the same column, indicating good discriminant validity between items.

Table 2: Reliability and Validity Test Results

		CITC	Cronbach after deleting item $\alpha$	Cronbach's $\alpha$	KMO	AVE	C.R.
Professionalism	A1	0.643	0.751	0.804	0.712***	0.580	0.805
	A2	0.653	0.731				
	A3	0.668	0.716				
Popularity	B1	0.659	0.766	0.820	0.718***	0.604	0.820
	B2	0.693	0.732				
	B3	0.668	0.757				
Content Quality	C1	0.597	0.748	0.789	0.703***	0.555	0.789
	C2	0.641	0.701				
	C3	0.650	0.691				
Visual Cues	D1	0.632	0.726	0.794	0.708***	0.564	0.795
	D2	0.657	0.700				
	D3	0.623	0.733				
Perceived Risk	G1	0.764	0.814	0.869	0.786***	0.631	0.872
	G2	0.672	0.852				
	G3	0.689	0.845				
	G4	0.759	0.817				
Perceived Functional Value	H1	0.638	0.726	0.797	0.711***	0.566	0.797
	H2	0.644	0.720				
	H3	0.639	0.725				
Purchase Intention	L1	0.748	0.809	0.863	0.804***	0.618	0.866
	L2	0.665	0.845				
	L3	0.693	0.832				
	L4	0.738	0.814				

\*\*\* indicates significant correlation at the 0.001 level (two-tailed)

Source: This study.

Table 3: Discriminant Validity

	Professionalism	Popularity	Content Quality	Visual Cues	Perceived Risk	Perceived Functional Value	Purchase Intention
Professionalism	<b>0.762</b>						
Popularity	0.636**	<b>0.777</b>					
Content Quality	0.678**	0.622**	<b>0.745</b>				
Visual Cues	0.603**	0.576**	0.669**	<b>0.751</b>			
Perceived Risk	0.641**	0.663**	0.687**	0.668**	<b>0.794</b>		
Perceived Functional Value	0.559**	0.631**	0.649**	0.591**	0.651**	<b>0.752</b>	
Purchase Intention	0.629**	0.582**	0.644**	0.544**	0.633**	0.650**	<b>0.786</b>

\*\* indicates significant correlation at the 0.01 level (two-tailed)

Source: This study.

### Model Fitting

To evaluate whether the previously proposed theoretical model is tenable, we used AMOS 23.0 to calculate the fitting index of the structural model. Above we have demonstrated that the data of each dimension of this scale has high convergent validity. Therefore, in the structural equation modeling analysis, we use the mean of scores under each dimension as the explicit variable. Table 4 shows that the model has a good fit.

Table 4: Model Fitting Results

	Indicators	Recommend value	Critical value	Model fitting value
Absolute fit index	GFI	> 0.8	> 0.9	0.989
	AGFI	> 0.8	> 0.9	0.680
	RMR	< 0.08	< 0.05	0.019
Relative fit index	CFI	> 0.8	> 0.9	0.991
	NNFI	> 0.8	> 0.9	0.818
	RFI	> 0.8	> 0.9	0.808

Source: This study.

### Path Analysis

We use AMOS 23.0 to conduct path analysis and test some hypothesis. Since the path analysis of the four dimensions of OTE on purchase intention reflects the direct effect rather than the total effect, the test results of H1-H4 can only be obtained in the mediation effect analysis. It can be seen from Table 5 that H8a is not supported at a significance level of 0.01.

Table 5: Path Analysis Results

	Estimate	S.E.	C.R.	P	Test Result
- Purchase Intention<---Professionalism	0.226	0.051	4.393	***	-
- Purchase Intention<---Popularity	0.055	0.050	1.085	0.278	-
- Purchase Intention<---Content Quality	0.181	0.057	3.156	0.002	-
- Purchase Intention<---Visual Cues	-0.012	0.051	-0.232	0.817	-

H5a	Perceived Risk<---Professionalism	0.149	0.048	3.109	0.002	Supported
H5b	Perceived Risk<--- Popularity	0.264	0.044	5.983	***	Supported
H5c	Perceived Risk<---Content Quality	0.258	0.051	5.031	***	Supported
H5d	Perceived Risk<---Visual Cues	0.265	0.046	5.804	***	Supported
H6	Purchase Intention<---Perceived Risk	0.155	0.055	2.821	0.005	Supported
H8a	Perceived Functional Value<--- Professionalism	0.047	0.053	0.889	0.374	Not Supported
H8b	Perceived Functional Value<--- Popularity	0.303	0.048	6.261	***	Supported
H8c	Perceived Functional Value<---Content Quality	0.311	0.056	5.544	***	Supported
H8d	Perceived Functional Value<---Visual Cues	0.183	0.050	3.655	***	Supported
H9	Purchase Intention<---Perceived Functional Value	0.284	0.050	5.642	***	Supported

\*\*\* indicates significant correlation at the 0.001 level (two-tailed)

Source: This study.

### Mediation Effect Test

This study used the Bootstrap method to test the mediation effect. The key data and test results have been summarized in Table 6. We record the explanatory variable as X, the mediating variable as M, and the explained variable as Y. Among them, a represents the regression coefficient of X to M; b represents the regression coefficient of M to Y; c represents the total effect of X on Y; c' represents the direct effect of X on Y; a\*b is the value of the mediating effect. Subsequently, we conducted hypothesis verification with reference to the mediation effect testing process proposed by Wen and Ye (2014). As can be seen from the Table 6, our study does not support H7d, H10a, and H10d, while other mediation effects hypotheses are supported.

In addition, We can also test the hypothesis of H1-H4 by observing the value of the total effect c. From the table below, it can be seen that at a significance level of 0.01, H1-H3 are supported, but H4 is not supported.

Table 6: Mediation Effect Test Results

	c	a	b	a*b	c'	P(a*b)	95% BootCI	Test Result
A=>G=>L								
H7a	0.262**	0.149**	0.155**	0.023	0.226**	0.239	0.000 ~ 0.086	Supported
B=>G=>L								
H7b	0.182**	0.264**	0.155**	0.041	0.055	0.084	0.004 ~ 0.101	Supported
C=>G=>L								
H7c	0.310**	0.258**	0.155**	0.040	0.181**	0.086	0.005 ~ 0.101	Supported
D=>G=>L								
H7d	0.081	0.265**	0.155**	0.041	-0.012	0.104	0.004 ~ 0.107	Not Supported
A=>H=>L								
H10a	0.262**	0.047	0.284**	0.013	0.226**	0.536	-0.024 ~ 0.062	Not Supported
B=>H=>L								
H10b	0.182**	0.303**	0.284**	0.086	0.055	0.011	0.034 ~ 0.168	Supported
C=>H=>L								
H10c	0.310**	0.311**	0.284**	0.088	0.181**	0.017	0.028 ~ 0.174	Supported
D=>H=>L								
H10d	0.081	0.183**	0.284**	0.052	-0.012	0.039	0.013 ~ 0.115	Not Supported

\*\*Indicates significant correlation at the 0.01 level (two-tailed)

Source: This study.

## CONCLUSION AND FUTURE WORK

### Results and Discussion

Our study tested the previously proposed theoretical model by conducting statistical analysis on the data collected from questionnaires. Next, we will discuss the research results from three aspects: the subject, the information and the mediation effect.

From the perspective of the subject of OTE. According to the test results, the professionalism of subject has a significant positive impact on consumers' purchase intention, and perceived risk plays a mediating role. This means that the higher the professionalism, the lower the risk consumers can perceive, thus enhancing the purchase intention. Our research does not support H8a and H10a, suggesting that professionalism does not affect consumers' judgment of product functions. One possible explanation is that most college students do not have the corresponding knowledge of chemical substances contained in beauty products. Therefore, although the subject uses professional vocabulary as much as possible to show professionalism, college students cannot change their judgment on the functional value of the product. Secondly, the popularity of subject can have a positive impact on the purchase intention, and the perceived risk and the perceived functional value play a mediating role. This shows that the more well-known the subject, the lower the risk consumers will perceive, and the higher the perceived functional value, making them more likely to make a purchase decision. This result also indicates that the influence of ordinary people on consumers' purchase intention may be far less than that of opinion leaders, because ordinary people are far less well-known than opinion leaders.

From the perspective of the information of OTE. The content quality can significantly and positively affect consumers' purchase intention. That is to say, if consumers can feel that the content is objective, truthful, and has reference value for them, their willingness to purchase products can be enhanced. However, visual cues, such as the diversity and eye-catching degree of presentation methods, do not have a significant impact on consumers' purchase intention. This may be because consumers may pay more attention to the information that can be obtained from OTE compared to visual stimuli, so they are obviously more concerned about the objective situation of the product itself, but not the way the information is presented. This suggests that OTE operators do not need to spend too much time and effort on video editing and word processing, but should delve deeper into the information of the product itself.

From the perspective of the mediation effect. We found that perceived risk has a mediating effect between professionalism, popularity, content quality, and purchase intention. This suggests that we can reduce the perceived risk of consumers by enhancing the professionalism, popularity, and content quality, and ultimately achieving the purpose of promoting consumption. On the other hand, perceived functional value only has a mediating effect between popularity, content quality, and purchase intention. This indicates that improving the perceived functional value by enhancing popularity of the subject and content quality is a feasible way to promote purchase intention. Our study does not support H7d and H10d, indicating that neither perceived risk nor perceived functional value have a mediating effect between visual cues and purchase intention. However, we found that in both hypotheses, although the total effect of visual cues on purchase intention is not significant, the indirect effect is significant. We attempted to conduct a correlation analysis between visual cues and purchase intention and found that the two were significantly correlated. Therefore, we speculate that in addition to perceived risk or perceived functional value, there may exist important mediating variables that transmit negative effects between visual cues and purchase intention.

### Management Implications

#### *Operators need to create a 'living sign'*

According to our empirical research results, operators are committed to enhancing professionalism of the subject, which helps to reduce the risks perceived by consumers in the process of information collection, and enhances consumers' willingness to purchase through the mediating role of perceived risk. Specifically, operators should first select individuals with higher education or senior qualifications in the beauty field as subjects, design scheme for them to better present a professional image, and provide professional training if necessary. During the explanation process, the subject should show his professionalism to the audience by using precise technical terms or showing rich achievements or experiences. In addition, operators also need to utilize various resources to enhance the popularity of the subject. The increase in popularity can reduce consumers' uncertainty in purchase decisions and enhance their subjective evaluation of product or service functions, thereby promoting consumer impulse to purchase. Specifically, OTE operators should actively expand their publicity channels and try to launch content on popular social platforms such as Tiktok to bring celebrity and popularity to the subject. The subject can also share some daily life updates on social accounts, which not only maintains the loyalty of fans, but also helps to shape their good image and enhance popularity.

#### *Operators need to focus on product content creation*

Under the background of the Internet era, online marketing methods of merchants emerge in an endless stream. But that has been followed by growing consumer doubts about whether OTE operators will engage in false advertising for profit. Operators must know that the basic demand for consumers to choose to refer to OTE lies in the authenticity and accessibility of

information. Therefore, in order to eliminate consumers' doubts about the authenticity of the content as much as possible, the content quality becomes more important. The improvement of content quality can reduce the uncertainty of consumers on the outcome of purchase decisions, and also improve consumers' functional perception of products or services, which ultimately leads to the enhancement of purchase intention. First of all, operators should adhere to the ethical bottom lines, delve deeper into product information and the reliability of the supply chain, ensuring that the products they recommend can not only meet the expectations of consumers, but also minimize the risks of fraud and security risks in the shopping process. Secondly, operators should use scientific and intuitive methods to conduct comprehensive and in-depth testing of products, and insist on objectively presenting the most realistic results to consumers. Although the findings suggest that visual cues do not significantly affect purchase intention, we believe that clear content presentation design is essential. Rich visual cues can indeed catch the eye of consumers and help them better understand the content. However, visual cues ultimately belong to the design of "icing on the cake", so OTE operators should not spend too much resources on the design of visual cues.

### **College students need to improve their ability of information recognition**

The consumer group of college students should comprehensively judge the subject's professionalism, popularity and content quality. Subjects with high degree of expertise and popularity can increase our purchase intention by weakening consumers' risk perception or enhancing perception of functional value. However, some operators may deliberately create a professional and well-known image for the presenter. Therefore, college students should carefully observe and judge whether the subject is reliant on backtracking or spending money to buy "zombie fans". We can also judge the personality and values of the subject by browsing his daily sharing, which can reduce the risk of "image deception" to some extent. In addition, college students should remember that content is the core of OTE. Good content should be able to truthfully and objectively convey useful product information to the audience, reduce our uncertainty about the consequences of purchase, but also make us more confident in the function of the product, thereby stimulating our strong desire to purchase. Specifically, college students can verify the authenticity of the content by browsing netizens' comments and observing whether the information conveyed by the OTE is seriously inconsistent with their feedback. At the same time, we should also make a horizontal comparison of OTEs that recommend the same product to examine the consistency of the conclusions. If the information and conclusions presented by multiple OTEs are consistent, then the content is likely to have authenticity and objectivity.

### **Research Limitations and Future Prospects**

Although this study has obtained certain results, there are also many limitations. (1) Due to the constraints of personal social circles, there are certain limitations in the representativeness of the sample in this study. Future studies can expand the sample scope, or use big data to obtain more comprehensive data to make the research results more representative. (2) The characteristic of OTE extracted in this study are few, and only four prominent dimensions are selected according to previous literatures. Future studies can incorporate the latest network trends to introduce more meaningful explanatory variables. (3) We only studied the influence of recommended OTE on purchase intention. Future research could examine dissuasive or comparative OTE. (4) As we mentioned before, in addition to perceived risk or perceived functional value, there may exist important mediating variables that transmit negative effects between visual cues and purchase intention. Future studies can try to identify this specific mediating variable or explore other possible explanations.

### **REFERENCES**

- Bae, J. T., Kim, B. Y., & Oh, S. H. (2019). The effects of brand value of oriental medicine cosmetic on purchase intention. *The Journal of Asian Finance, Economics and Business*, 6(2), 105-117. <https://doi.org/10.13106/jafeb.2019.vol6.no2.105>
- Bansal, H. S., & Voyer, P. A. (2000). Word-of-mouth processes within a services purchase decision context. *Journal of service research*, 3(2), 166-177. <https://doi.org/10.1177/109467050032005>
- Bauer, R. A. (1960). Consumer behavior as risk taking. In *Proceedings of the 43rd National Conference of the American Marketing Association, June 15, 16, 17, Chicago, Illinois, 1960*. American Marketing Association.
- Bhattacharjee, A., & Sanford, C. (2006). Influence processes for information technology acceptance: An elaboration likelihood model. *MIS quarterly*, 30(4), 805-825. <https://doi.org/10.2307/25148755>
- Biswas, D., Biswas, A., & Das, N. (2006). The differential effects of celebrity and expert endorsements on consumer risk perceptions. The role of consumer knowledge, perceived congruency, and product technology orientation. *Journal of advertising*, 35(2), 17-31. <https://doi.org/10.1080/00913367.2006.10639231>
- Chen, Y. F., Tsai, C. W., & Lin, P. H. (2017). The influence of perceived risk, shopping value and opinion leader to explore online consumer purchase intention: Using social network analysis. *International Journal of E-Adoption (IJEA)*, 9(2), 31-58. <https://doi.org/10.4018/IJEA.2017070103>
- Choi, G. Y., & Behm-Morawitz, E. (2017). Giving a new makeover to STEAM: Establishing YouTube beauty gurus as digital literacy educators through messages and effects on viewers. *Computers in Human Behavior*, 73, 80-91. <https://doi.org/10.1016/j.chb.2017.03.034>
- Davis, A., & Khazanchi, D. (2008). An empirical study of online word of mouth as a predictor for multi-product category e-commerce sales. *Electronic markets*, 18(2), 130-141. <https://doi.org/10.1080/10196780802044776>
- Dodds, W. B., Monroe, K. B., & Grewal, D. (1991). Effects of price, brand, and store information on buyers' product evaluations. *Journal of marketing research*, 28(3), 307-319. <https://doi.org/10.1177/002224379102800305>
- Forsythe, S., Liu, C., Shannon, D., & Gardner, L. C. (2006). Development of a scale to measure the perceived benefits and risks of online shopping. *Journal of interactive marketing*, 20(2), 55-75. <https://doi.org/10.1002/dir.20061>



- Gomes, M. A., Marques, S., & Dias, Á. (2022). The impact of digital influencers' characteristics on purchase intention of fashion products. *Journal of Global Fashion Marketing*, 13(3), 187-204. <https://doi.org/10.1080/20932685.2022.2039263>
- Kaplan, L. B., Szybillo, G. J., & Jacoby, J. (1974). Components of perceived risk in product purchase: A cross-validation. *Journal of applied Psychology*, 59(3), 287-291. <https://doi.org/10.1037/h0036657>
- Kleut, J., Pavličková, T., Picone, I., De Ridder, S., Romić, B., & Hartley, J. M. (2018). Emerging trends in small acts of audience engagement and interruptions of content flows. *The future of audiences: A foresight analysis of interfaces and engagement*, 123-140. [https://doi.org/10.1007/978-3-319-75638-7\\_7](https://doi.org/10.1007/978-3-319-75638-7_7)
- Marsh, J. (2016). 'Unboxing' videos: co-construction of the child as cyberflâneur. *Discourse: Studies in the cultural politics of education*, 37(3), 369-380. <https://doi.org/10.1080/01596306.2015.1041457>
- Meng, F. (2012). Research on the influence of opinion leaders on purchase intention in a social business environment. *Doctoral dissertation, Nanjing: Nanjing University*. (in Chinese).
- Mullet, G. M., & Karson, M. J. (1985). Analysis of purchase intent scales weighted by probability of actual purchase. *Journal of marketing research*, 22(1), 93-96. <https://doi.org/10.2307/3151555>
- Netemeyer, R. G., & Bearden, W. O. (1992). A comparative analysis of two models of behavioral intention. *Journal of the Academy of Marketing Science*, 20(1), 49-59. <https://doi.org/10.1177/009207039202000105>
- Pahlevan Sharif, S., & Mura, P. (2019). Narratives on Facebook: the impact of user-generated content on visiting attitudes, visiting intention and perceptions of destination risk. *Information Technology & Tourism*, 21(2), 139-163. <https://doi.org/10.1007/s40558-019-00140-7>
- Pan, N. (2023). Research on the impact of anchor characteristics on consumer purchase intention in online live broadcasts. *Master thesis. Wuhan: Hubei University*. (in Chinese).
- Shen, W., Guo, J., & Li, H. (2013). Research on information quality and reliability evaluation of online communities - based on user perspective. *Modern Library and Information Technology*, (1), 69-74. (in Chinese).
- Sheth, J. N., Newman, B. I., & Gross, B. L. (1991). Why we buy what we buy: A theory of consumption values. *Journal of business research*, 22(2), 159-170. [https://doi.org/10.1016/0148-2963\(91\)90050-8](https://doi.org/10.1016/0148-2963(91)90050-8)
- Simová, J., & Cinkánová, L. (2016). Attributes contributing to perceived customer value in the Czech clothing on-line shopping. *E&M Ekonomie a Management*, 19(3), 195-206. <https://doi.org/10.15240/tul/001/2016-3-013>.
- Stone, R. N., & Grønhaug, K. (1993). Perceived risk: Further considerations for the marketing discipline. *European Journal of marketing*, 27(3), 39-50. <https://doi.org/10.1108/03090569310026637>
- Sweeney, J. C., & Soutar, G. N. (2001). Consumer perceived value: The development of a multiple item scale. *Journal of retailing*, 77(2), 203-220. [https://doi.org/10.1016/S0022-4359\(01\)00041-0](https://doi.org/10.1016/S0022-4359(01)00041-0)
- Till, B. D. (1998). Using celebrity endorsers effectively: lessons from associative learning. *Journal of product & brand management*, 7(5), 400-409. <https://doi.org/10.1108/10610429810237718>
- Vaudrey, R. K. (2022). A practice unpacked: Unboxing as a consumption practice. *Journal of Business Research*, 145, 843-852. <https://doi.org/10.1016/j.jbusres.2022.03.021>
- Wang, M. -Z. (2021). Research on the impact of mobile short video user-generated brand content quality on consumer purchase intention. *Master thesis. Taiyuan: Shanxi University of Finance and Economics*. (in Chinese).
- Wen, Z. -L., & Ye, B. -J. (2014). Mediating effect analysis: Method and model development. *Advances in Psychological Science*, 22(5), 731. (in Chinese).
- Zeithaml, V. A. (1988). Consumer perceptions of price, quality, and value: a means-end model and synthesis of evidence. *Journal of marketing*, 52(3), 2-22. <https://doi.org/10.1177/002224298805200302>
- Zeithaml, V. A., Parasuraman, A., & Malhotra, A. (2002). Service quality delivery through web sites: a critical review of extant knowledge. *Journal of the academy of marketing science*, 30(4), 362-375. <https://doi.org/10.1177/009207002236911>

## Research on the Model Innovation and Governance Strategy of Jiangsu Green Supply Chain Finance Development under the Digital Background

Yao Liu <sup>1</sup>  
Fei Xu <sup>2</sup>  
Jiaqi An <sup>3</sup>  
Shun Zhang <sup>4</sup>  
Yaqin Dou <sup>5,\*</sup>

\*Corresponding author

<sup>1</sup> Undergraduate student, Nanjing Institute of Technology, Nanjing, China, 1736234109@qq.com

<sup>2</sup> Undergraduate student, Nanjing Institute of Technology, Nanjing, China, 1835994204@qq.com

<sup>3</sup> Undergraduate student, Nanjing Institute of Technology, Nanjing, China, 1776864793@qq.com

<sup>4</sup> Undergraduate student, Nanjing Institute of Technology, Nanjing, China, 1918977211@qq.com

<sup>5</sup> Professor, Nanjing Institute of Technology, Nanjing, China, douyq@njit.edu.cn

### ABSTRACT

With the development of digital technology, the importance of green supply chain finance (GSCF) in achieving the "Dual Carbon Goals" has become increasingly apparent, which has attracted numerous attention from scholars at home and abroad. However, there are currently some shortcomings in the research on promoting the deep integration of digital technology and GSCF, as well as the innovation and application of regional GSCF models. This article takes Jiangsu Province as the research object, and based on the background of digital technology, analyzes the current development status, models, and trends of GSCF in Jiangsu Province. Conduct research on obstacles and governance strategies. The research results indicate that the basic development status of Jiangsu GSCF has been significantly improved in product innovation, green platform construction, ecological environment optimization, and risk prevention and control. Based on the practice of Jiangsu GSCF, innovative financial models are explored for three scenarios: "Jiangsu Carbon Melting", "Environmental Protection Guarantee", and "ESG Credit Loan". However, obstacles still exist in implementing standards and related regulations, information infrastructure construction, ecosystem risk control system, and composite talent support system. Therefore, this study suggests establishing multiple linkage mechanisms, improving standards and regulations, consolidating infrastructure construction, and stimulating development momentum. Strengthen the integration of digital technology, comprehensively prevent risks, improve the talent support system, and enhance carrying capacity.

*Keywords:* Dual carbon goals, Green supply chain finance, Digital technology, Model innovation.

### INTRODUCTION

China has made a strong declaration of the "Dual Carbon" goals for the first time. Jiangsu is a major manufacturing province and currently in a high stage of information technology development. Under the "Dual Carbon" goals, the development of green economy is facing enormous opportunities and challenges. With the increasingly widespread application of digital technology in various industries, accelerating the process of digital transformation, stimulating the green vitality of agriculture, increasing the green power of industry, strengthening the green capabilities of the service industry, and promoting the realization of Jiangsu's "Dual Carbon" goals are of great significance for promoting China's economic and social development. GSCF is a business innovation that integrates the development of green finance and green industries, and an important booster for effectively implementing the "Dual Carbon" strategy. Therefore, it is particularly important and urgent to conduct research on the innovative development of Jiangsu GSCF based on the background of the main driving forces of the digital economy at this stage. Based on the digital background, this article summarizes the current research status of GSCF at home and abroad, analyzes the development status of GSCF in Jiangsu Province, explores the practical mode of GSCF in Jiangsu Province, and proposes corresponding governance strategies for the obstacles faced by the development of GSCF in Jiangsu Province.

At present, domestic and international research related to this study mainly includes aspects such as the connotation, function, operating mode, constraints, and countermeasures of GSCF. In recent years, some scholars have explored the connotation, structure, and theoretical framework of GSCF. Arbia *et al.* (2018) proposed that smart supply chain finance (SSCF) should include the cooperation of supply chain management, efficient operation, predictive maintenance and inventory optimization. Cao *et al.* (2019) studied a secondary supply chain that includes a supplier and a manufacturer, taking into account the situation of carbon trading and financial constraints on manufacturers, and found that credit financing is often due to bank financing. Domestic scholars have interpreted GSCF from both a narrow and a broad perspective, enriching the theoretical content of GSCF.

Shan (2019) believes that the narrow concept of green supply chain finance is relatively small compared to GSCF, and only refers to the use of supply chain finance as a product among numerous financial models to support the development of green industries. The broader definition of GSCF also includes the provision of green financial services to enterprises with outstanding performance in GSCF management. Broadly speaking, GSCF focuses on integrating green finance with supply chain finance (SCF) and green supply chains, with the common goal of minimizing adverse impacts while creating environmental, social, and economic benefits for stakeholders. Qian (2019) believes that GSCF is the organic integration of green finance, SCF, and green supply chain. Li and Xu (2022) believe that GSCF is an organic combination of green finance, SCF, and green supply chain. Yang and Feng (2023) believe that GSCF is a new financing method that innovatively integrates existing SCF, green finance and green supply chains (GSC), emphasizing the green investment direction of funds.

With the continuous improvement of the ecological structure and internal mechanism of GSCF, more scholars are continuously exploring the functions and roles of GSCF. Hu (2017) believes that the introduction of a GSC mechanism can help reduce the environmental impact of heavy pollution and high consumption capacity. Through the transmission of SCF environmental information and mutual supervision and control of environmental behavior at upstream and downstream SCF nodes, the enterprises involved in exporting capacity are bound to fulfill their environmental responsibility within the industrial chain, not only meeting domestic environmental compliance requirements, but also taking extended responsibility for the raw material supply from the production capacity output and upstream regions, which can enhance the local enterprises' environmental awareness and capacity building. Yang *et al.* (2019) studied financing strategies in green supply chains constrained by funds under decentralized and centralized decision-making. They believe that for supply chains that produce green products, retailers should take incentive measures to encourage manufacturers to innovate in green technology and produce products with higher green content. Ding *et al.* (2020) found that green credit support helps to strengthen the tendency to adopt decisions; The greater the discount on green credit interest rates and the higher the financing ratio, the more incentive the supply chain can adopt higher levels of low-carbon technologies; By discussing a reasonable cost sharing ratio within the supply chain, the dual optimization of investment returns and low-carbon technology adoption level can be achieved.

The development of digital technology has injected new impetus into GSCF. The application of digital technology in green supply chains has begun to attract scholars' attention, and further research is being conducted on the operational mode of GSCF. Yang (2020) designed a relatively complete GSCF risk comprehensive evaluation index system, optimized the indicators through effectiveness testing and sensitivity analysis, applied principal component analysis to reduce the dimensionality of the indicators, and used Logit model to evaluate the risk of GSCF, and compared the evaluation results with the BP neural network model. Tao (2021) constructed an internet trading platform, introduced environmental information disclosure from suppliers, established an information interaction mechanism between suppliers, banks, and core enterprises, promoted the greening of the entire industry chain, and constructed a new GSCF model. Zhang and Zhang (2021) explored the benefit allocation of GSCF under uncertainty conditions and constructed a multi-objective programming model for GSCF benefit allocation. More scholars have combined the actual situation of GSC operations and addressed the practical issue of funding constraints faced by green R & D enterprises, exploring the operational and financing decisions of financially constrained enterprises under green single-channel and green dual-channel SCF respectively. Zhang *et al.* (2022) constructed supply chain models under three financing modes, namely no financing mode, manufacturer financing mode, and retailer financing mode, while considering financing risks. They compared the green level of products and supply chain performance under these three financing modes.

As an emerging field that has received much attention, relevant scholars have found that there are many constraints in the development process of GSCF, and have also proposed corresponding countermeasures. Zhang (2021) believes that in the face of high-pressure policies to protect the environment, most small and medium-sized enterprises are unable to achieve low-cost operations and bear high environmental pollution compensation fees, and have not earned sufficient profits to repay their debts, resulting in financing difficulties in the supply chain once again. Therefore, developing GSCF is a priority. Tao and Chih (2020) found that in practice, many manufacturing or retail enterprises that adopt clean technology supply chains lack market competitiveness due to high costs, which hinders their green production activities. Li (2023) believes that companies themselves have a low level of confidence in green upgrading, and their ability to control carbon emissions and environmental protection throughout the logistics process is relatively weak. Additionally, due to technological limitations, the implementation effects of green design, green production, and green recycling have not met expectations, resulting in most companies being unable to accurately measure the external economic effects brought by GSCF. Suggestions are proposed to improve green procurement and green supply chain evaluation standards, and develop green supply chain evaluation and certification tools. Liu and Wang (2023) believe that the structure and services of GSCF products are relatively single. Domestic green finance still focuses on green credit and green bonds, with a relatively simple product structure and little difference from traditional business. It is recommended to actively innovate GSCF products, expand investment and financing scale, and effectively promote the development of green finance.

There have been relevant studies on GSCF both domestically and internationally, laying a solid theoretical foundation for its future development. However, there are still the following issues worth further exploration: (1) How to use digital technology as the main means and the Internet as an important carrier of a new economic to empower the GSCF industry, and how to promote the deep integration of digital technology and GSCF is an urgent problem that needs to be solved. (2) There is a lack of research on the innovation and application of regional GSCF models, including research on the achievements of some practical models

of GSCF both domestically and internationally, the comprehensive risk evaluation index system, and the distribution of benefits under uncertain conditions. Therefore, based on the theoretical research on GSCF both domestically and internationally, this article takes Jiangsu Province as the research object, analyzes the current development status of GSCF in Jiangsu Province, uses digital technology to empower GSCF, and constructs an innovative model for the development of GSCF in Jiangsu Province. It proposes the obstacles faced by the development of GSCF in Jiangsu Province and formulates corresponding governance strategies.

## **THE BASIC STATUS OF GSCF DEVELOPMENT IN JIANGSU UNDER THE UNDER THE DIGITAL BACKGROUND**

### **Using Financial Product Innovation as a Means to Build a Multi-level Financial Service System**

Actively guiding banking financial institutions and core enterprises in the industrial chain to create a "Fin Tech+SCF" scenario, constructing models such as "SCF+Green Finance", "Green Supply Chain+SCF", and "Green Supply Chain+Green Finance", promoting "Environmental Loans", "Green Innovation Investment", "Water-saving Loans", and "Carbon Neutral Bonds". Innovative products such as "Carbon Quota Pledge Loans" and "GSCF" have been launched, relying on the green supply chain system established by core enterprises and referencing the green ratings of suppliers by core enterprises or third parties to provide differentiated SCF services. The Jiangsu Banking and Insurance Regulatory Bureau encourages banking institutions to innovate green financing products, develop green SCF, and prudently carry out environmental equity collateral financing such as carbon emission rights. Encourage insurance institutions to follow the trend of low-carbon development, enrich green insurance products, and explore differentiated insurance premium rate mechanisms. Research shows that China's main green financial products cannot meet the various investment and financing needs of green enterprises. Financial institutions should innovate green financial products, strive to meet the various investment and financing needs of green enterprises, lay the foundation for incubating surplus enterprises in the supply chain, and guide social funds to flow to green areas in the supply chain through the application of SCF products, in order to reduce environmental impact and resource consumption in the supply chain management process. To promote the development of green finance more effectively, based on the existing green finance service products that are related to people's production and life problems, we will launch new products, enrich products and services, and establish a strong, reliable, and safe policy support for the green finance system in Jiangsu Province.

### **Using Digital Platform Construction as the Engine to Drive Information Flow Sharing among Industrial Enterprises**

In order to strengthen the collaboration between upstream and downstream enterprises in the supply chain, Jiangsu actively built a green SCF platform after the 14th Five Year Plan and strengthened cooperation among various enterprises. At present, Jiangsu has established 13 local credit reporting platforms and 22 financial service platforms; In 2020, Ant Financial's block-chain+supply finance platform has been established in Xuzhou Economic Development Zone, and Jiangsu Bank has launched the "SCF Cloud Platform"; In 2021, China Telecom Jiangsu Branch held a press conference on the SCF service platform. Upgrade and renovate the unified registration and publicity system for movable property financing in 2021, and launch the "Sunong Cloud" platform; In 2022, the "Electric E-Financial Service" platform of State Grid of China and the "Chain E-Finance" platform of Zijin Rural Commercial Bank were successfully operated. Establish a multi-party environmental information sharing platform, integrate public information platform data around green supply chain operations, provide channels for information exchange and sharing for upstream and downstream enterprises in the supply chain, and form an open and shared green supply chain big data information platform. Relying on the platform effect, we will attract upstream, midstream, and downstream enterprises, establish and improve the standards and management system for green SCF business and products, promote the strategic plan of "Horizontal Linkage And Vertical Integration, weaken the error of information communication, and lay the foundation for the overall integration of the industrial chain enterprise. Enable small and medium-sized enterprises in the supply chain to have channels to understand the upstream and downstream business situation, while sensing the business interaction between external markets, so as to flexibly adjust their business plans and connect various links of the industrial chain for high-quality development of GSCF.

### **Guided by Ecological Environment Optimization, Promoting the Development of GSC**

In recent years, Jiangsu has continuously optimized the institutional environment and increased the "Green Coverage" of SCF services in response to the demand for "Carbon Reduction" in the process of industrial development. According to research by Ren and Zhu (2021), Jiangsu Province will continue to deepen green finance reform and achieve low-carbon development. The Jiangsu Provincial Department of Industry and Information Technology has issued a notice on deepening the promotion of green finance to promote industrial green and low-carbon development, proposing to "Establish and improve a multi-level and diversified supply system of green financial products covering the entire province". The Jiangsu Banking and Insurance Regulatory Bureau also encourages insurance institutions to practice green and low-carbon operations in creating a good environment for green finance, actively promote environmental information disclosure, and strengthen financial exchange and cooperation. At present, Jiangsu Province has 63 green branches and 6 green and low-carbon transformation financial service centers. Jiangsu Bank, Zijin Rural Commercial Bank, and Nanjing Bank have announced the adoption of the United Nations' 《Principles of Responsible Banking》, actively promoting the development of green finance, and gradually forming a strategic layout from point to surface. Promoting the low-carbon transformation of traditional industries and the development of new energy industries, strengthening business regulation and regulation, and fostering clusters and strong industrial chains. Currently, Jiangsu Province has 10 national advanced manufacturing clusters, and has established 56 secondary nodes for online industrial internet identification and analysis, forming a strategic layout with nodes in 13 cities and full coverage of key industries.

Continuously promote technological innovation and guide financial institutions and industries to upgrade their financial technology by relying on technologies such as tax big data, the Internet of Things, and block-chain. The optimization and improvement of ecological environment such as policy system, cluster level, industrial maturity, and financial technology application have greatly expanded the breadth and depth of digital SCF application, effectively promoting the high-quality development process of green SCF in Jiangsu Province.

### **Building a Multi-channel Green Regulatory Mechanism with the Aim of Reducing Financial Risks**

In 2020, the China Banking and Insurance Regulatory Commission and the Department of Ecology and Environment jointly issued the 《Guiding Opinions on Strengthening Environmental Credit Construction and Promoting Green Finance Work》, which required the implementation of differentiated environmental pollution liability insurance for insurance and financial institutions; In 2021, the Jiangsu Banking Green Finance Professional Committee was established, providing clearer guidance for the banking and insurance industry to enhance its green development capabilities in financial services; In 2022, the China Banking and Insurance Regulatory Commission issued the 《Action Plan for Deepening Green Financial Services in the Jiangsu Banking and Insurance Industry》, which specifies that in terms of financial risk prevention mechanisms, institutions are required to strengthen forward-looking management and prevent high costs and risks in the green transformation of financial enterprises. The current development goals of Jiangsu Provincial Bank include reducing the risks of green finance business. The government is committed to improving the risk identification and early warning capabilities of regulatory agencies, conducting dynamic review and supervision of the entire chain and process of SCF business, and effectively curbing various fraudulent behaviors such as cashing out and counterfeiting through a multi-pronged approach. Wang (2021)'s research shows that achieving real-time, transparent, mutually verified, and traceable information data in supply chain operations and financial activities. Xu (2020)'s research proposes to pay attention to risk prevention in the application process of SCF and improve risk prevention and control capabilities. At present, we are exploring the distributed and immutable characteristics of information transmission such as block-chain to quickly and accurately promote information transmission on the green supply chain, enhance the accurate identification ability of potential risks for upstream and downstream enterprises in the green supply chain, and expand the financing choices of enterprises through platform financial institutions and the release of numerous financial products; The platform shares information on financing entities, and financial institutions conduct risk reviews and evaluations of enterprises; The platform enterprise publishes financing needs for multiple financial institutions to evaluate and compete, improve financing efficiency and financing service level, and promptly adjust financing services for the enterprise once problems are found. In addition, supply chain entities and government regulatory agencies impose sanctions on enterprises that violate green principles, permanently blacklist enterprises that cheat on loans under the name of green, and order regulatory agencies to rectify such enterprises, in order to safeguard the high-quality development of Jiangsu Province's GSCF.

### **INNOVATION IN THE DEVELOPMENT MODEL OF GSCF IN JIANGSU PROVINCE UNDER THE DIGITAL BACKGROUND**

This section will explore innovative GSCF models such as "Jiangsu Carbon Finance", "Environmental Protection Guarantee", and "ESG Credit Loan" based on the practice of Jiangsu GSCF.

#### **Jiangsu Carbon Melting Model**

The core concept of the Su Carbon Finance model is that green small and medium-sized enterprises in the supply chain apply for loans from banks based on the carbon reduction information of their products and the low-carbon rating information of the carbon exchange. Banks automatically calculate the carbon reduction emissions of enterprise products through the carbon accounting model embedded in the platform and include them in the enterprise carbon account. The credit limit and interest rate are linked to the carbon account of the lending enterprise, and credit decisions are made based on this. This financing model utilizes technologies such as big data and block-chain to achieve the "De Nucleation" of traditional SCF, enhancing the multi-level penetration ability of the underlying carbon assets of green enterprises. With a focus on "Innovating the Digital Engine for Pollution Reduction and Carbon Reduction" and "Building a Smart System for Green Growth", it reconstructs the correlation model of supply chain investment and financing entities, optimizes supply chain relationships, and reduces SCF costs.

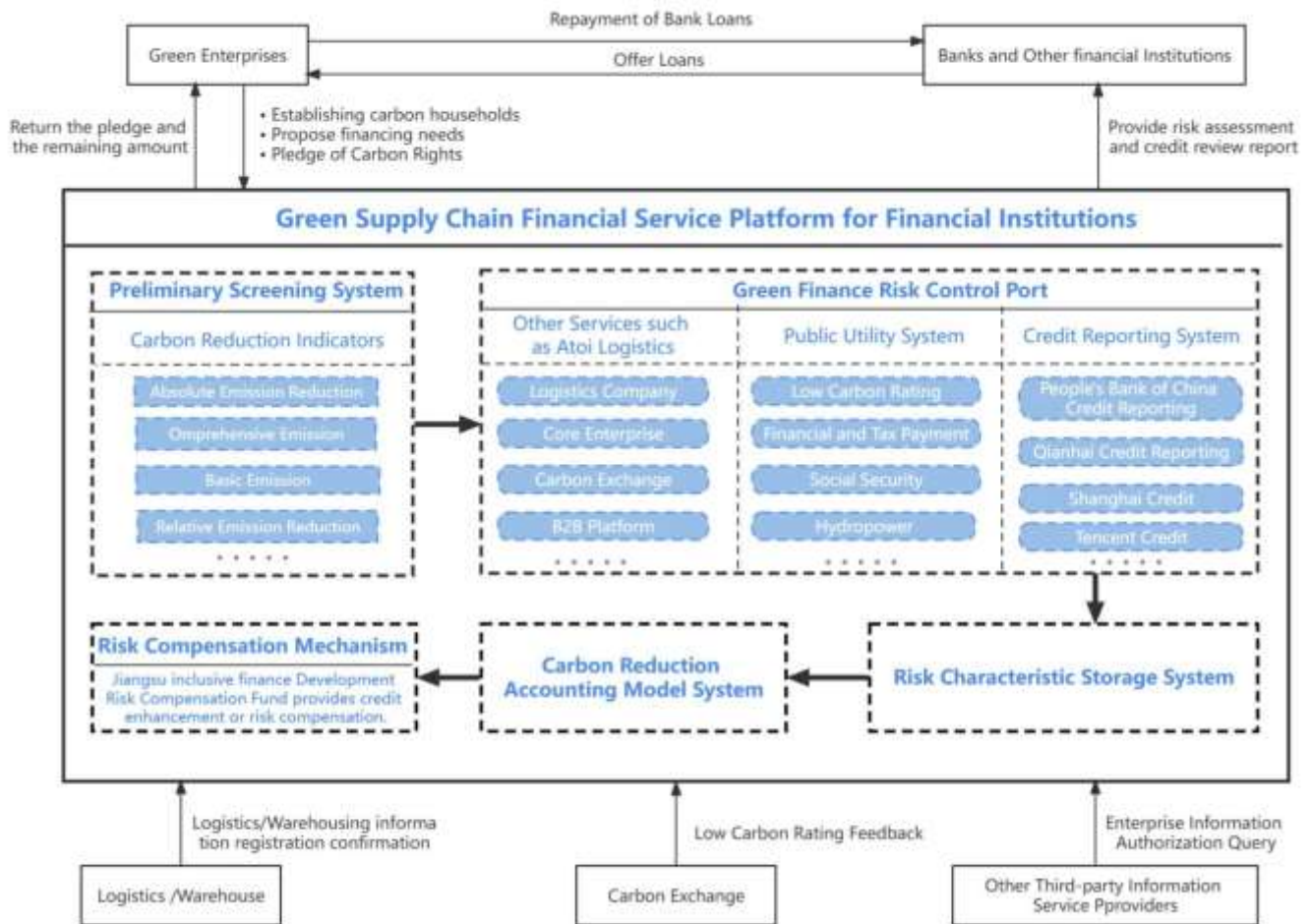

Figure 1: Operation process of Jiangsu carbon melting model.

As shown in Figure 1, after obtaining a low-carbon rating from the carbon exchange, enterprises involved in green loans in the supply chain submit an application for a Jiangsu Carbon Finance loan to the bank through the platform, along with relevant information that can prove their credit conditions, including basic information (Business License, Financial Statements, Tax Records, etc.), credit information (Proof of Loan Purpose, Shareholder Meeting or Board of Directors Loan Resolution, etc.), Green information proof (Production, Procurement, Logistics, etc.), etc. Based on the electronic materials, logistics warehousing, and other third-party interactive verification information submitted by the financing party, the Jiangsu Carbon Rong platform utilizes an intelligent screening system to complete preliminary screening of financing enterprises for basic emissions, absolute emission reduction, and other indicators. It enters the green finance risk control port and relies on financial technology means to clean data from different dimensions on the operating status, credit status, and carbon reduction level of financing enterprises, Obtain enterprise carbon reduction emissions through the platform carbon reduction accounting model, and integrate with the logistics system, public service system, and other credit reporting systems to confirm and cross validate the secondary profile of supply chain enterprise risks. Record the results into the risk feature storage system, and provide credit enhancement or risk compensation through the Jiangsu Province Inclusive Financial Development Risk Compensation Fund. Finally, the bank will make credit limit and interest rate decisions based on comprehensive enterprise loan application materials, platform risk assessment, and credit enhancement review.

### Environmental Protection Guarantee Model

Environmental protection responsibility, "Is an SCF service model suitable for the environmental protection industry, with participants including not only industrial enterprises, but also governments, re guarantee groups, and financial institutions. The important feature of the operation of the "Environmental Protection Guarantee" model is the joint establishment of the "Environmental Protection Guarantee Project Library" by the government and the re guarantee group, which evaluates and screens the declared projects from two aspects: Green Environmental Protection & Financial Risks, providing a basis for guarantee institutions and commercial banks to formulate differentiated rate preferential policies. In the "Environmental Responsibility Guarantee" model, the government, re guarantee groups, and financial institutions form a risk sharing pattern, combining the credit level of environmental protection enterprises and project risk differences, to provide differentiated guarantees for enterprise project loans. It is worth noting that the "Environmental Protection Guarantee" model is based on fiscal funds, reducing guarantee rates and financing interest rates by adding new guarantee compensation funds and establishing risk



compensation, and then amplifying leverage effects through re guarantee group credit enhancement, providing low threshold and low-cost credit enhancement and credit services for environmental protection enterprises that meet policy support.

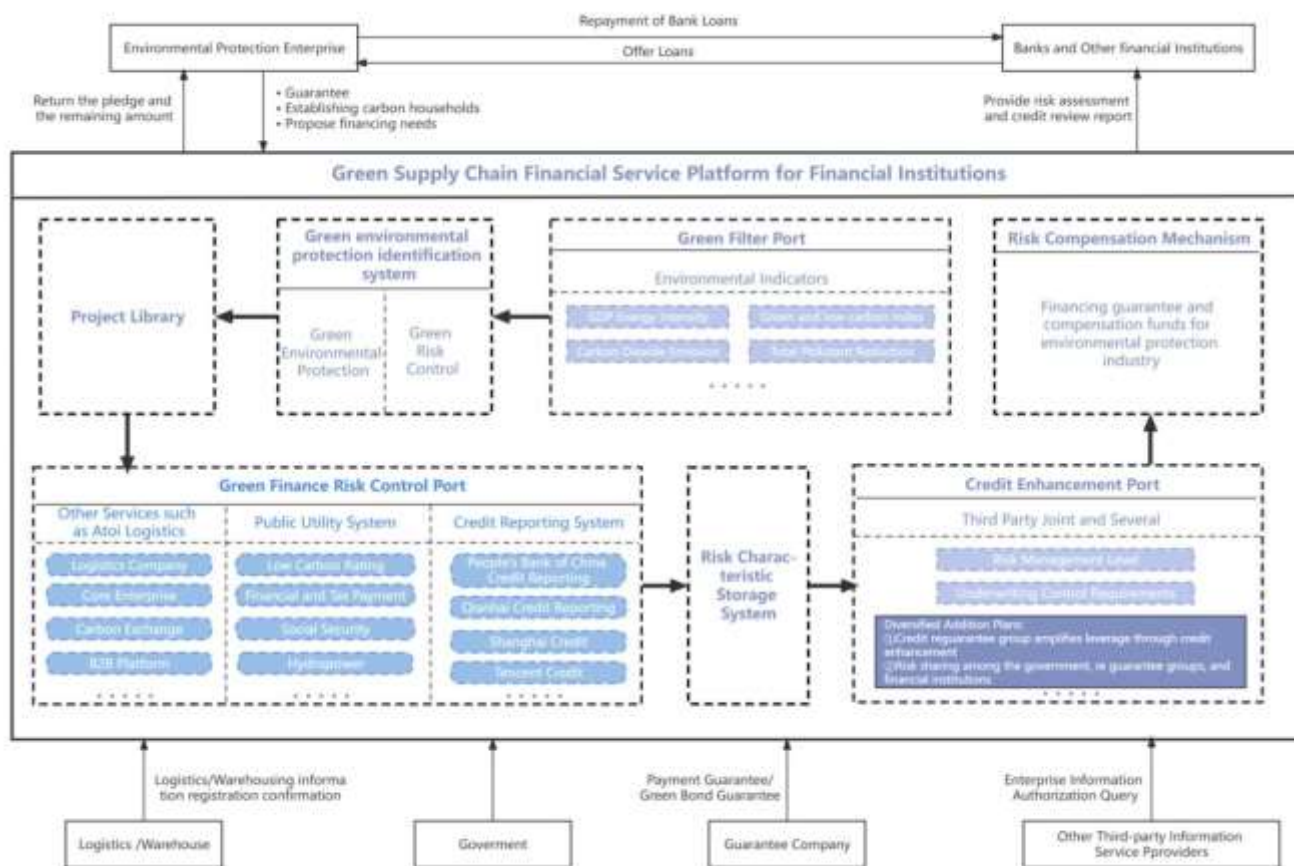

Figure 2: Operation process of environmental protection guarantee model.

As shown in Figure 2, environmental protection enterprises submit relevant materials that can prove their credit conditions through the Environmental Protection Guarantee platform. After submitting a project loan application to the bank, the platform conducts qualification screening for enterprise projects based on the electronic materials submitted by the enterprise for the loan project, combined with interactive verification information from third parties, and data such as individual GDP energy consumption and carbon dioxide emissions of the project, Conduct a comprehensive review from the perspectives of green environmental protection and risk control. Specifically, verification is carried out through an embedded green environmental protection identification system, and the selected projects are entered into the "Environmental Protection Project Library" to determine differentiated rate discounts. At the same time, the project's business prospects, market positioning, industry development trends, etc. are evaluated to clarify the project's risks, and the risk assessment results are recorded in the risk feature storage system. Then, through the green credit enhancement port, diversified credit enhancement is implemented, and institutions such as the government and re guarantee groups provide project loan guarantees for environmental protection enterprises through guaranteed compensation funds or establishing risk compensation. Finally, the bank will make decisions on the project loan credit limit, guarantee rate, and loan interest rate based on comprehensive enterprise project loan application materials, platform risk assessment, and credit enhancement review.

### ESG Credit Loan Model

ESG Credit Loan, "Is a carbon emission quota pledge loan tailored for low-carbon enterprises. In the operation of ESG credit loan model, green enterprises apply for loans from the platform based on carbon reduction data of their products and environmental and social governance data required for ESG rating. The platform's ESG rating system uses various information technology tools to provide ESG rating for the enterprise's environmental and social performance. Banks link the ESG rating results with multiple factors such as interest rate, term, and guarantee method to make credit decisions. The prominent advantage of the ESG credit loan model is to encourage enterprises to achieve green and low-carbon transformation, promote enterprises to timely demonstrate their transformation efficiency through quantitative and comparable environmental information disclosure, and promote the tilt of financial resources towards low-carbon projects and low-carbon enterprise allocation.



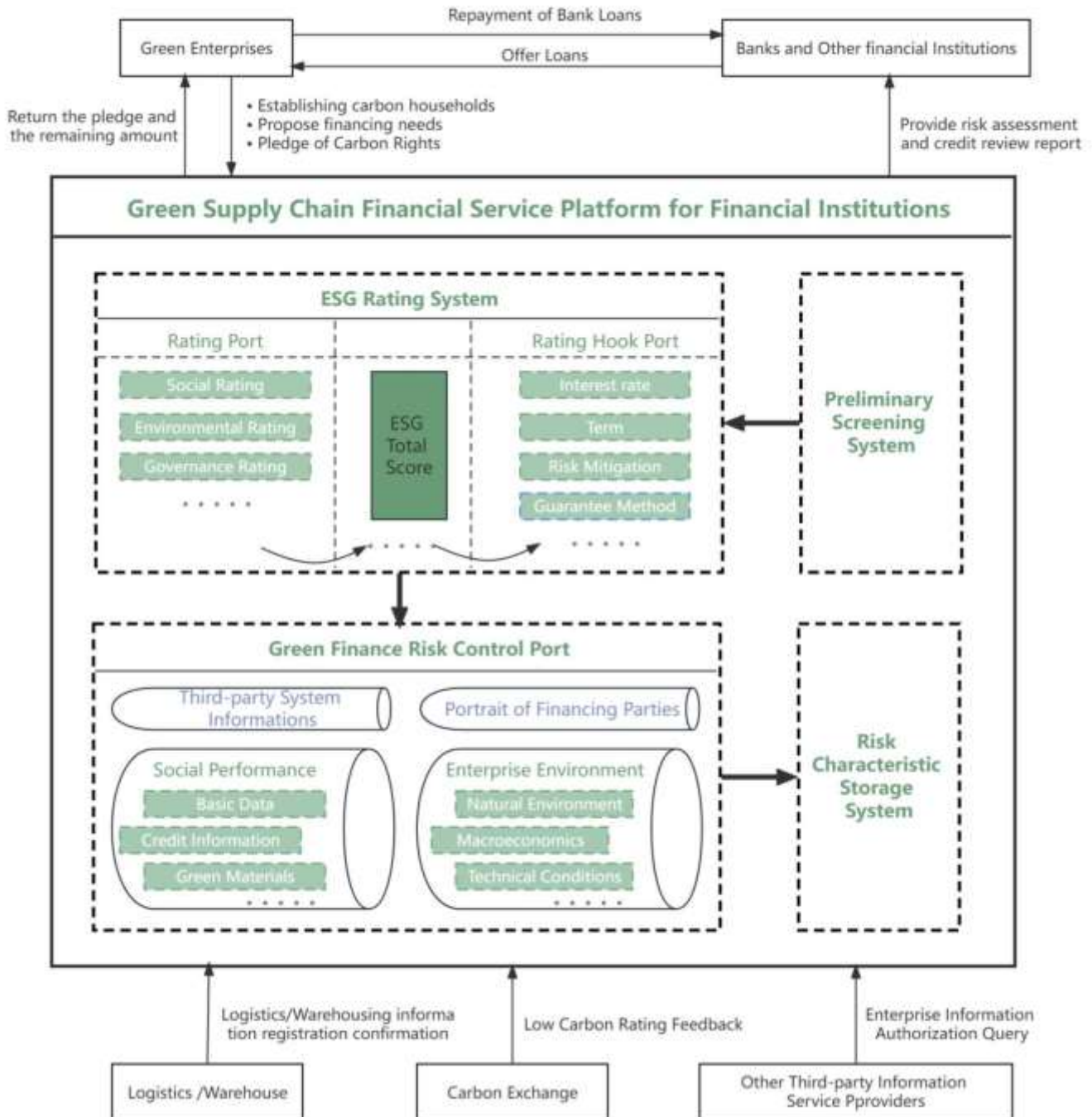

Figure 3: ESG credit loan model operation process

As shown in Figure 3, green loan enterprises in the supply chain submit carbon exchange low-carbon ratings and other materials that can support credit conditions to the platform (such as Production and Operation Materials, Financial Reports, Green Production and Sales Information Certificates, etc.). After submitting a project loan application to the bank, the platform stores the information into the ESG rating system and obtains real-time ecological environment protection based on artificial intelligence technology, block-chain distributed storage technology, and peer-to-peer technology. Environmental management, environmental investment, environmental punishment information, etc. are evaluated and rated for environmental performance. Information on human resources, compensation and benefits, public welfare and poverty alleviation is obtained for social performance rating. Information on equity and shareholders, information disclosure, external guarantees, etc. is obtained for governance performance rating. ESG rating scores are obtained by combining the three aspects of evaluation. The rated project enters the platform's risk control port, and combines non-financial indicators such as enterprise environment and social performance to conduct risk assessment on the lending enterprise, and stores the results in the risk characteristic storage system. The platform links ESG rating results and risk assessment results with multiple factors such as interest rates, terms, and risk mitigation measures to meet the needs of green enterprises or projects in terms of price, term, guarantee methods, and reduce

financing costs. Finally, the bank will make credit limit and loan interest rate decisions based on comprehensive enterprise loan application materials, platform risk assessment, and ESG credit performance rating.

## **OBSTACLES TO THE DEVELOPMENT OF JIANGSU GSCF UNDER THE DIGITAL BACKGROUND**

### **Lack of Implementation Standards and Related Specifications**

In 2021, Jiangsu issued 30 "Green Gold Measures" and in 2022, 18 "Green Financial Service Actions", promoting the comprehensive upgrading of the green financial service system. In the context of digitalization, SCF has also shown new features in terms of service targets, service methods, and service platforms, further providing more convenient and technological financial services for corporate customers. At present, the GSCF concept, business scope, product system, service strategy, and other aspects are comprehensively defined in the "GSCF Business Guidelines" formulated by Industrial Bank, but there is no clear explanation for the relevant standards such as the construction of GSCF operation platform and product operation. Therefore, although the green finance standard system in Jiangsu is gradually improving, there is a lack of authoritative institutions defining GSCF product standards. In the process of transforming digital service channels, the content and coverage of GSCF services will become wider, and there are also significant differences in the recognition standards of GSCF business by financial institutions. At the same time, the integration of finance and industry has become increasingly in-depth in the context of digitalization, and all parties involved in the supply chain can connect across borders through internet platforms. GSCF business involves numerous entities such as financial chains, industrial chains, logistics enterprises, e-commerce institutions, and government departments, and the difficulty of unified identification across industries has also been magnified in this context. At the same time, GSCF is closely integrated with the operation and characteristics of the industrial chain, and there are significant differences in the main business needs and application scenarios in different industrial chains, which increases the difficulty of establishing GSCF standards.

Driven by the development of theory and practice, SCF related regulations are becoming more and more complete. However, existing policies lack normative guidance on environmental factors and social responsibilities related to SCF business, and there is no corresponding standard for the follow-up supervision of green production behavior and the use of green credit funds. In addition, the relevant legal system of GSCF needs to be fully developed. With the rapid development of the digital economy, the online and digital business innovation of GSCF has accelerated, bringing a large number of legal issues to platform finance qualifications and license approval, smart contract recognition, data rights confirmation, etc. The legislative lag has seriously hindered the high-quality development of GSCF.

### **Weak Information Infrastructure Construction**

Although Jiangsu has closely followed the background of the digital era in recent years and increased investment in information infrastructure construction, the overall scale, number of application enterprises, and number of standard formulation have achieved good results. The construction of digital infrastructure is on the fast track, the speed of industrial digital transformation is accelerating, and the creation of supply chain information sharing platforms is now developing rapidly in China's computer information technology level. The combination of green supply chain and computer technology can achieve better development, ushering in a new "Foundation" for the high-quality development of GSCF. However, there is still room for improvement in terms of coverage, service capabilities, technological level, data and computing power center construction, especially in the integration and application of digital technology in the SCF field.

Firstly, in the context of low technological integration, Jiangsu's existing provincial credit reporting and financial service platforms, as well as its 13 local credit reporting platforms and 22 financial service platforms, have failed to effectively integrate and apply technologies such as Block-chain, Internet Of Things, and Artificial Intelligence, making it difficult to meet the high-quality development needs of digital SCF in terms of business efficiency, transaction recognition, logistics control, and risk prevention and control. The technical challenges of low technological integration are mainly reflected in: firstly, the high digital cost, even higher than the interest margin; Secondly, data silos are the norm, and to integrate information flow, business flow, logistics, and capital flow, multiple parties need to participate in system transformation, and the degree of customization is very high; Thirdly, there is a lack of low-cost data development paradigms, which increases the interconnectivity of industrial chain data.

Secondly, in the absence of unified interface standards, it is difficult for upstream and downstream enterprises, financial institutions, logistics enterprises, and other participants to form a unified data standard, resulting in a lack of basic technical standards for the digital SCF platform, resulting in inconsistent information system interfaces between the platform and participating entities such as financial institutions, industrial enterprises, and logistics. The industry information sharing system has not yet been established, and the entry of batch business data is restricted. At the same time, personalized interfaces also reduce the platform's operational efficiency, leading to an increase in platform operating costs.

Finally, in the context of low integration of industry and technology, currently, Jiangsu's banking industry mainly relies on cooperation with institutions such as internet platforms, data companies, Fintech companies, and supply chain integration service providers to develop Fintech, achieving technology and scenario integration through partner cloud platforms. However, it has not been deeply integrated into supply chain scenarios, and the integration of industry and technology is not high. Customized

technical solutions are easily detached from the pain points and demands of supply chain value, Restricting the service quality and efficiency of digital SCF.

### **The Ecosystem Risk Control System is not Sound**

#### ***Lack of External Risk Prevention Measures***

Many institutions that lead the SCF business have weak perception and response capabilities to external risks brought about by macro level financial systems, economic cycles, industrial policies, epidemic impacts, and changes in natural and cultural environments, and lack measures to prevent external environmental risks.

#### ***Overly Strengthening Core Enterprise Functions***

When promoting SCF business, financial institutions excessively strengthen the credit enhancement and guarantee functions of core enterprises, failing to truly control financial risks from the perspective of supply chain network architecture and business structure quality. The "Strong Core" supply chain organizational structure and business design will increase the difficulty of technology penetrating the bottom layer of assets, bringing huge hidden dangers to the risk control of the ecosystem system.

#### ***Low Correlation of Supply Chain Information***

Financial institutions and warehousing, logistics, transportation and other links lack a standardized transaction management system. In the context of digital development, Jiangsu Province has failed to establish an effective information exchange platform. The low correlation of process information in each transaction link, as well as the lack of regulatory constraints and reputation governance mechanisms for supply chain participants, have increased the endogenous risk of SCF, leading to "Collusion and Fraud" Pseudo SCF events such as "False Trade" and "Duplicate Financing" often occur, resulting in lower enthusiasm for the development of green finance in various departments (Liu & Chen , 2022).

### **Incomplete Support System for Composite Talents**

Talent support is one of the key factors for GSCF to achieve high-quality development. In recent years, the number of SCF business companies has grown rapidly, and the application of digital technology in GSCF has led to a significant shortage of related composite human resources. The market urgently needs composite talents who master green supply chain management, finance, and digital technology.

According to the "Research Report on the Employment Impact of Digital Economy" by the China Institute of Information and Communications, with the digital transformation of the entire society and industry, there is a significant gap in digital talent in China, and the imbalance in the distribution of digital talent has also had a negative impact on the sustainable development of digital GSCF in Jiangsu Province. Faced with the strengthening of digital trends, the innovative development of GSCF relies on the innovative thinking and ability of financial technology talents. Currently, there is a lack of GSCF composite talent training system from the government, society, and universities. The government has not proposed a strategic plan for the cultivation of GSCF technical talents from the top-level design. Social training institutions do not systematically train GSCF composite talents, and universities seriously lag behind market demand in cultivating GSCF talents. Many new technologies seriously lag behind practical needs in theory. As a strong province in education, many universities in Jiangsu Province have launched financial courses, but only a few universities, such as Nanjing University, specifically offer green finance courses, There is significant room for improvement in the cultivation of green finance talents.

The serious shortage of composite talents is an important bottleneck that restricts the development of GSCF, mainly manifested in three aspects:

#### ***Lack of Long-term Planning for Talent Cultivation***

There is a lack of institutional construction and strategic planning for the cultivation of GSCF composite talents, an effective coordination mechanism between talent supply and demand entities, and a comprehensive collaborative education mechanism. The channels for updating and supplementing knowledge of composite talents are not smooth.

#### ***Insufficient Innovation in Talent Cultivation System***

There is a lack of incentive policies for interdisciplinary integration, and universities generally lack a platform for horizontal interdisciplinary integration. There are few resources for interdisciplinary integration courses, and traditional disciplines such as supply chain management, finance, and computer technology have long had invisible "Boundaries". The single disciplinary talent cultivation model has significant limitations, which restricts the quality of GSCF's composite talent cultivation.

#### ***The Talent Guarantee Mechanism is not yet Sound***

An effective talent guarantee mechanism has not yet been established, and the growth and development channels for composite talents are not smooth. Currently, the pain points of the shortage of high-level composite talents in the digital SCF of major banks in Jiangsu are concentrated in "Unable to Recruit", "Unable to Attract", and "Unable to Retain". The lack of a comprehensive talent support system is an important bottleneck restricting the development of Jiangsu GSCF.

## GOVERNANCE STRATEGIES FOR THE DEVELOPMENT OF GSCF IN JIANGSU PROVINCE UNDER THE DIGITAL BACKGROUND

As an innovative model of green finance, GSCF helps to optimize the allocation structure of financial resources in green production, and is also a positive manifestation of social responsibility, helping to achieve carbon peak and carbon neutrality goals. At present, the development of GSCF in Jiangsu Province is still in the exploratory stage. Based on this, this article proposes governance strategies and suggestions for the development of GSCF in Jiangsu Province from four aspects: improving standards and norms, strengthening information infrastructure construction, improving ecosystem risk control, and building a composite talent support system under the digital background.

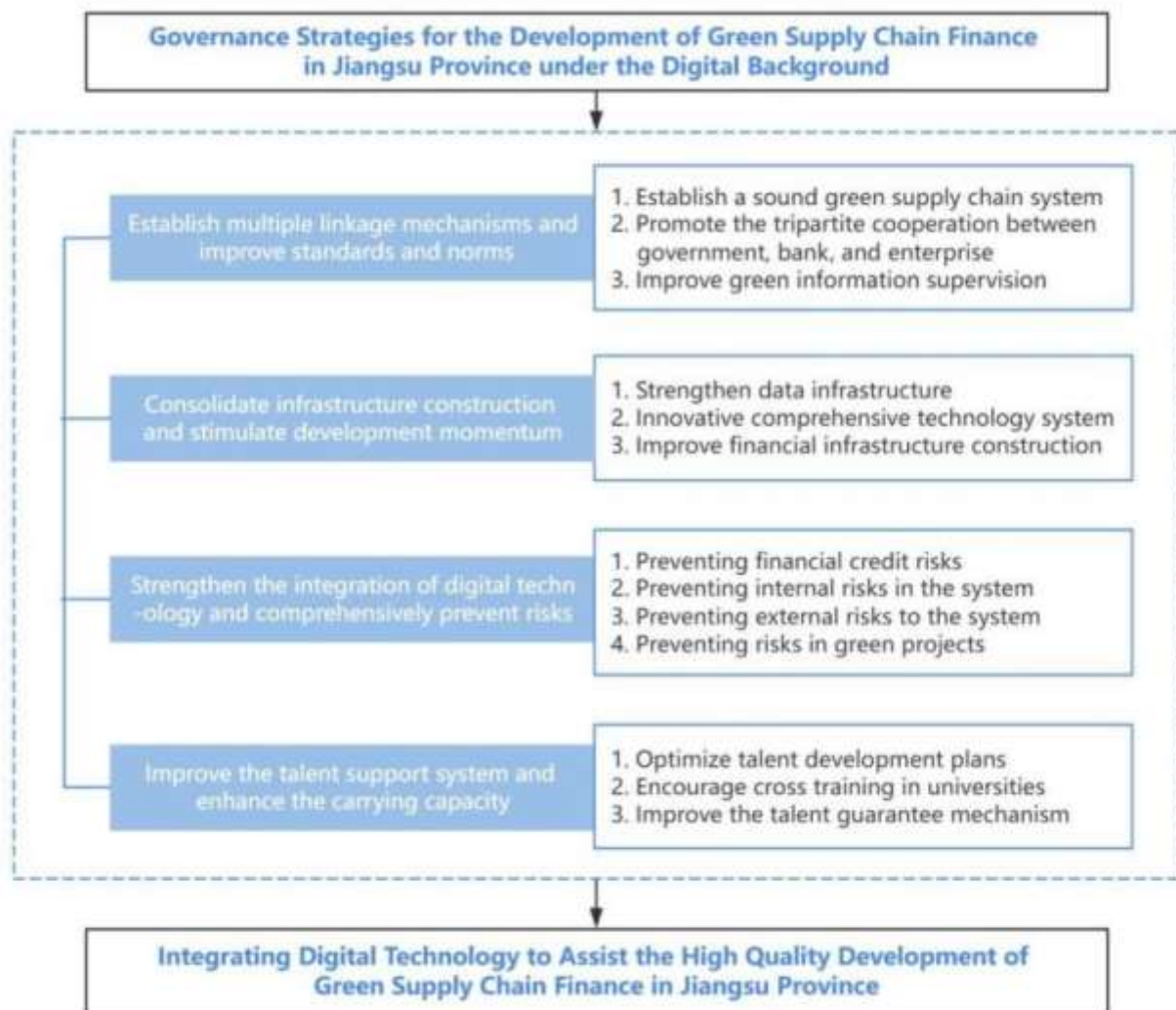

Figure 4: Governance strategies for the development of GSCF in Jiangsu under the digital background

### Establish Multiple Linkage Mechanisms and Improve Standards and Norms

At present, Jiangsu Province lacks authoritative institutions to define the GSCF product standards, and there are significant differences in the main business needs and application scenarios in different industrial chains with different structures. In this regard, Jiangsu should improve the local regulatory system for green investment and financing, work together from multiple parties, and strive to improve the GSCF standard system.

### Establish a Sound GSCF System and Establish a Multi-party Force Mechanism

Shan and Deng (2021) suggest that the ecological and environmental authorities collaborate with other relevant departments to develop top-level design policies and standards for green supply chain management, and develop relevant standards for ecological environment protection in green finance and green supply chain management. Faced with the current difficulties in the development of GSCF in Jiangsu Province, the government should promote the establishment of a multi-party linkage mechanism in conjunction with the bank credit reporting system and third-party information providers. Based on the green finance standard system and existing SCF related laws and regulations, local exploration should be combined to develop differentiated standards for GSCF in different regions. Intelligent rating should be carried out based on the business ability and credit status of enterprises, improve credit standards, and enhance risk control capabilities. Increase control over key points of fund return. Adhere to the principle of combining the top-level design of the central government with local specificity, increase

the construction of green SCF policy system based on reality, improve the GSCF standard system, and promote the healthy and sustainable development of GSCF.

### ***Promote the Tripartite Cooperation between Government, Bank, and Enterprise, and Clarify the Main Responsibilities of the Three Parties***

In the early stages of the development of GSCF, the government should take the lead in assisting the tripartite cooperation between government, enterprises, and banks, mobilizing the confidence and enthusiasm of all participating entities in GSCF. Guo *et al.* (2023) proposed that achieving green and low-carbon energy transformation under the "Dual Carbon" goal has become a common pursuit of all trading entities across the region. The government should promptly introduce programmatic documents to promote the development of the GSCF model, especially information disclosure, digital rules, and bill rules, clarify regulatory subjects, directions, and priorities, improve policy regulatory efficiency, and reduce credit risks. For green enterprises participating in financing, support will be provided through re guarantees, multi-party credit enhancement, and other means to lower interest rates for supply chain member enterprises. Support for low-carbon innovation activities and green transformation of enterprises will be increased through loan discounts, tax reductions, and the establishment of risk compensation funds.

### ***Improve Green Information Supervision and Strengthen the Entire process Supervision Mechanism***

To improve the green information supervision mechanism for the entire supply chain, it is first necessary to establish and improve relevant laws and regulations, and provide policy guidance; Secondly, it is necessary to strengthen data sharing with green service intermediaries, attach importance to green certification of enterprises, and strengthen green environmental performance evaluation and green auditing; Finally, it is necessary to strengthen the extended supervision of green production and operation of financing enterprises. Through on-site and off-site investigations, the subsequent use of green credit funds and green production behavior of enterprises should be continuously tracked and monitored. Based on the characteristics of the green industry, industry reports and real-time data should be referenced for comprehensive rating, and default and fraudulent financing enterprises should be blacklisted to promote the full process supervision of green information.

### ***Consolidate Infrastructure Construction and Stimulate Development Momentum***

At present, Jiangsu should take "Advanced industrial foundation and modernization of industrial chain" as an important driving force, comprehensively consolidate infrastructure construction, and stimulate development momentum.

### ***Strengthen Data Infrastructure and Consolidate Information Support Efficiency***

Jiangsu needs to accelerate the construction of green big data financial infrastructure, strengthen the application of block-chain technology to enhance the transparency and security of green environmental information and financial information, provide data support for green information identification and financial supervision of financial institutions, track the flow of green credit funds in real-time, and promote the safe and high-quality development of GSCF. Establish an information docking platform between GSCF and green projects, alleviate the problem of inconsistent information infrastructure construction in the north and south regions of Jiangsu Province, achieve deep integration of information resources, effectively promote the symmetry of green supply chain information in Jiangsu Province, and comprehensively consolidate the data foundation.

### ***Innovate the Comprehensive Technology System and Improve the Quality of Multi-party Services***

Jiangsu financial institutions should delve into the application scenarios of green supply chains and green projects, build a comprehensive technical service system across borders and time and space based on the existing green supply chain infrastructure, improve performance integration level, and expand green efficiency. At the same time, we need to use technologies such as the Internet of Things, big data, and block-chain to build a digital ecosystem, and empower the development of GSCF in Jiangsu Province with technological innovation. Ma *et al.* (2021) proposed that using commercial banks as an example, financial technology tools such as big data, block-chain, and artificial intelligence can be used to establish an ESG credit management system that covers the entire process. The development of GSCF in Jiangsu Province should establish a comprehensive green supply chain financing service platform that includes risk identification, ESG rating, risk feature storage, payment settlement, account management, wealth management, and other functions, to achieve real-time data monitoring and collection, improve the operational efficiency and service quality of financial institutions, reduce resource energy consumption, and effectively solve efficiency problems such as information circulation and fund financing, Enhance the support of green supply chain through comprehensive services.

### ***Improve Financial Infrastructure and Standardize Industry Standard System***

Increase Jiangsu's financial investment in green industry development and ecological environment governance, increase financial support for GSCF product innovation, technological innovation, model innovation, etc., focus on improving factor allocation efficiency, promote balanced development of financial infrastructure construction in Jiangsu Province, drive the restructuring of GSCF related entity models, promote green investment and financing system reform, and comprehensively expand the supply and demand scale of green supply chain investment and financing. Governments, banks, and enterprises should promote the application of new technologies such as big data and block-chain in the construction of the GSCF information platform, starting from multiple aspects such as technology application system and composition, credit product composition elements, risk feature identification and prevention, and improving the information, technology, and credit product standard system to enhance the efficiency of GSCF and achieve green development of SCF and the financial industry itself.

### **Strengthen the Integration of Digital Technology and Comprehensively Prevent Risks**

In the context of digitalization, in response to the risks in risk control of the GSCF ecosystem system in Jiangsu Province, it is necessary to strengthen the integration of digital technologies such as the Internet of Things, big data, and block-chain, in order to reduce financial credit risks, internal risks, external risks, and specific risks of green projects.

### ***Preventing Financial Credit Risks and Bridging the Shortcomings of the Digital Ecology***

In response to the infrastructure bottlenecks and communication shortcomings in the digital ecosystem of Jiangsu Province, we will empower the key and weak points of the entire SCF chain with new infrastructure, build a public digital green service platform, promote the deep integration of financial information and investment and financing activities, and use the "Big Smart Move Cloud" to bridge the shortcomings of credit transmission difficulties and information silos in the interconnection between finance and supply chain, and improve the processing efficiency of the block-chain data platform. Technological innovations such as consensus mechanisms have been implemented to achieve SCF "De Nucleation" and information classification and storage. Improve the disclosure standards of information for entities at all levels, enhance the multi-level penetration ability of underlying assets, reduce financial risks, introduce third-party guarantee institutions on the basis of the tripartite coordination of "Government, Bank, and Enterprise", and achieve the joint efforts of "Government, Bank, and Enterprise Guarantee" to prevent credit risks of entities.

### ***Preventing Internal Risks in the System and Reconstructing the Subject Association Model***

We need to create a transparent, safe, and efficient green digital ecological environment, reconstruct the correlation model of supply chain investment and financing entities, and improve the relationships between various participating entities in the supply chain. Enterprises should enhance their awareness of green environmental protection and integrity, and strengthen the trust and goodwill between commercial banks and enterprises. This balance of trust and mutual benefit between banks and enterprises will form a soft constraint on credit risks between commercial banks and enterprises. However, the advantage of credit rating cannot fundamentally eliminate the inherent risks in the system. In order to reduce the negative impact of risk transmission in the supply chain, it is necessary to strengthen the application and innovation of financial technology methods, enhance the risk control ability of key nodes and weak links in the supply chain, embed risk assessment ports in the intelligent supply chain system, and form a quantitative model by monitoring the enterprise's operating status, credit status, carbon reduction level, etc. By utilizing big data technology to verify and value the authenticity and value of accounts receivable and prepayments, a precise portrait is formed and stored in the risk control prompt port, improving the risk identification and warning capabilities of regulatory agencies, and effectively curbing various illegal behaviors such as cash out and fraud through multiple measures.

### ***Preventing External Risks in The System and Enhancing Risk Response Capabilities***

Changes in external factors such as policy norms, macroeconomics, and cultural environment can all affect the financing process and results of enterprises. The rapid iteration of products has led to difficulty in predicting the market value of collateral, thereby increasing the difficulty of SCF pledge services. Liu and Liu (2021) proposed that supply chain enterprises should strengthen cooperation and adopt methods such as early payment and delayed payment through trade credit for internal financing to reduce external dependence. For force majeure such as natural disasters and abnormal social events, prevention and resolution can be achieved through cooperation with third-party insurance service platforms to establish a "Government Bank Enterprise Insurance" linkage and docking mechanism. Except for force majeure, most risk factors can be perceived and addressed by humans. By making the digital ecosystem transparent, we aim to achieve balanced sharing of information among various regions in Jiangsu Province. Through collaboration among cities, we aim to establish a response mechanism that is compatible with risk identification and risk feature storage systems, quantify risks, and enhance the sensitivity, insight, and prevention and control capabilities of the SCF ecosystem towards external environmental risk factors such as laws, market policies, and economics.

### ***Preventing Green Project Risks and Promoting the Development of Green Intermediaries***

Real time green assessment and supervision throughout the entire process of GSCF should be carried out. Enterprises should consciously establish a green and low-carbon concept, implement energy conservation, emission reduction, and protection of green resources. Before applying for green credit, they need to apply to the carbon exchange to open a carbon account and receive feedback on low-carbon ratings. When manufacturers are segmented, the competitive relationship between enterprises changes, and different behavioral decisions of manufacturers will have a significant impact on enterprise profits. Therefore, it is necessary to closely follow changes in market demand and prevent green project risks. Promote the rapid development of green intermediary service institutions such as carbon accounting and verification, green certification, environmental consulting, green asset assessment, ESG rating, etc., establish a green certification center database, establish a green project library, open up green information sharing mechanisms, integrate credit condition certificates provided by enterprises, feedback information from green intermediary service institutions, and feedback information from other third-party intermediary institutions, and further establish a comprehensive evaluation, review, finance A green low-carbon enterprise and project identification, certification, and risk management system that integrates multiple functions such as financing and risk control, promoting the reliable development of GSCF.

### **Improve the Talent Support System and Enhance the Carrying Capacity**



Currently, the supply of GSCF talents in Jiangsu Province is far below market demand. Jiangsu should focus on improving its talent support system, opening up channels for talent mobility, and comprehensively enhancing the carrying capacity of GSCF through multiple approaches.

#### ***Optimize Talent Cultivation Plans and Promote Talent Supply and Demand Matching***

The establishment of a talent support system needs to rely on the top-level design of composite talents, develop a composite talent training system and strategic plan through cross departmental and cross system approaches, and develop a GSCF technology leading talent training plan in the digital context, cultivating composite talents who not only possess SCF knowledge and professional abilities, but also proficient in financial technology means. Faced with the current imbalance in the supply and demand of composite talents, financial institutions should provide digital training for financial and accounting professionals with strong abilities and good quality to achieve human resource upgrading. At the same time, it is necessary to effectively connect supply and demand in advance, pay attention to exploring human resources channels such as higher education institutions, research institutions, and local governments in Jiangsu, encourage universities, institutions, employers, and social organizations to jointly run schools, focus on the demand characteristics of GSCF business for composite talents, and work together from both theoretical and practical aspects to cultivate high-quality SCF composite talents and promote precise matching of supply and demand for composite talents.

#### ***Encourage Cross Disciplinary Training in Universities and Revitalize Interdisciplinary Resources***

As an important main battlefield for talent cultivation, universities should play a bridging role in the GSCF talent cultivation process. The school should establish a "Three in One" talent cultivation goal, grasp the hierarchy and flexibility of talent cultivation, pay attention to the comprehensive quality requirements of the market for composite talents, not only utilize existing subject resources in the undergraduate teaching process, but also establish comprehensive interdisciplinary master's and doctoral programs, deepen the cultivation of research talents, business talents, and technical talents, and expand the field of high-level innovative talent cultivation. At the same time, we will formulate disciplinary integration incentive policies to encourage universities to embed "Big Intelligence Transfer Cloud" related technologies into supply chain management, finance, financial management and other disciplinary systems, cultivate high-end composite talents of "Supply Chain Management+Green Finance+Digital Technology", and provide inexhaustible intellectual support for the development of GSCF.

#### ***Improve the Talent Guarantee Mechanism and Innovate Management Service Policies***

Establish an innovation and entrepreneurship talent introduction platform, reform the talent evaluation mechanism, fully mobilize incentive and health factors, not only establish a fair and just salary system, but also continuously improve the talent reward and welfare mechanisms, and integrate spiritual rewards with material rewards. Dou *et al.* (2022) proposed that all sectors of society should focus on strengthening the cultivation of compound talents and opening up channels for talent flow. Combining the Jiangsu "Ten Million Talents Plan" and the "Talent Strengthening Province Strategy", we will comprehensively innovate the policy and system of SCF composite talent management services, provide technical training services and systematic personnel support for professional talents, vigorously promote the GSCF composite talent introduction and training action, and take multiple measures simultaneously. We not only need to "Introduce" talents, but also "Stay", Provide strong talent support for the high-quality development of GSCF in Jiangsu Province under the digital background.

### **CONCLUSION**

This article systematically reviews the domestic and international development status of GSCF, analyzes the current situation of GSCF based on the digital background, explores innovative practical models of GSCF, analyzes the practical difficulties that constrain GSCF, and seeks governance strategies for the development of GSCF in Jiangsu Province. Firstly, in the context of dual carbon goals and digitization, based on domestic and international research, a systematic theoretical review of the connotation, function, operating mode, constraints, and countermeasures of GSCF has been conducted, laying a good foundation for the future development of GSCF and exploring the problems that this article can solve. Secondly, in the context of digitalization, the current situation of GSCF development in Jiangsu Province was explored, including four situations: led by product innovation, enriched financing service system, driven by digital platform construction, improved information sharing level, guided by ecological environment optimization, promoting GSCF development, aimed at risk prevention and control, and constructing multi-channel green regulatory mechanisms. Once again, based on the background of digital technology, while exploring the practice of GSCF in Jiangsu Province, we have innovated the practical mode of GSCF in Jiangsu Province, focusing on the process design and key points of the three modules of "Jiangsu Carbon Melting Model", "Environmental Protection Guarantee Model", and "ESG Credit Loan Model". Finally, in response to the current obstacles in the development of Jiangsu GSCF under the digital background, such as the lack of implementation standards and related norms, weak information infrastructure construction, incomplete ecosystem risk control system, and a lack of composite talents, it is proposed to establish multiple linkage mechanisms, improve standards and norms, consolidate infrastructure construction, stimulate development momentum, strengthen digital technology integration, comprehensively prevent risks, and improve talent support system Four governance strategies to enhance carrying capacity.

### **ACKNOWLEDGMENT**

This work was financially supported by the Innovation and Entrepreneurship Training Key Programs for College Students in Jiangsu 2023 : Research on the model innovation and governance strategy of Jiangsu green supply chain finance development



under the digital background (202311276043Z), China; the Major Project of Jiangsu University Philosophy and Social Science Research 2021: Research on the competition and cooperation mechanism and coordination strategy of private enterprise supply chain investment and financing from the perspective of symbiosis theory (2021SJZDA132), China; the Special Project of Jiangning District Reform and Development Research Center 2023 : Research on the inner mechanism and operating mechanism of the deep integration of the innovation chain, industry chain, and capital chain in Jiangning district for the co creation of subject value. (JNGF202301), China; the Open Research Fund of NJIT Institute of Industrial Economy and Innovation Management: Research on sustainable poverty reduction mechanism and policy optimization of agricultural supply chain finance under the guidance of agglomeration advantage (JGKB202101), China; the Major Projects of Innovation Fund of Nanjing Institute of Technology 2020: Research on innovation and promotion path of credit agglomeration mode of Jiangsu agricultural supply chain finance under the background of new infrastructure construction (CKJA202004), China.

#### REFERENCES

- Arbia Riahi Sfar, Enrico Natalizio, Yacine Challal & Zied Chtourou. (2018). "A roadmap for security challenges in the Internet of Things." *Digital Communications and Networks*, 4(2), 118-137. <https://doi.org/10.1016/j.dcan.2017.04.003>.
- Cao, E., Du, L., & Ruan, J. (2018). "Financing preferences and performance for an emission-dependent supply chain: supplier vs. bank." *International Journal of Production Economics*, 208. <https://doi.org/10.1016/j.ijpe.2018.08.001>.
- Shan, M.W. (2019). "Research on green supply chain finance model with multi-party participation." *Environment and Sustainable Development*, (03), 64-67. <https://doi.org/10.19758/j.cnki.issn1673-288x.201903064>.
- Qian, L.H., Lu, Z.W., & Fang, Q. (2019). "Three major development models of green supply chain finance." *China Banking*, (08), 78-79. <https://doi.org/10.1007/s11628-016-0325-2>.
- Li, S.Y., & Xu, X.Y. (2022). "Research on Green Supply Chain Finance Mode of Wood Forest Products." *Logistics Sci-Tech*, (08), 160-163. <https://doi.org/10.1080/02642069.2022.2104257>.
- Yang, X., & Feng, B. (2023). "Green Supply Chain Finance Practice and Risk Prevention." *Hainan Finance*, (03), 47-54. <https://doi.org/10.3969/j.issn.1003-9031.2023.03.005>.
- Hu, D.W., Wang, J., & Jiang, W.Y. (2017). "Study on the Management Mechanism of Green Supply Chain under the Background of the Belt and Road." *Environmental Protection*, (16), 19-24. <https://doi.org/10.14026/j.cnki.0253-9705.2017.16.003>.
- Yang, H.X., & Duan, W.Y. (2019). "Research on Financing Mode for Capital Constrained Manufacturer in Green Supply Chain." *Operations Research and Management Science*, 28(8), 8. <https://doi.org/10.1037/10805-000>.
- Ding, Z.G., Xu, H.W., & Xu, Q. (2020). "Decision-making of Low-carbon Technology Adoption in Supply Chain Supported by Green Credit." *Soft Science*, (12), 74-80. <https://doi.org/10.13956/j.ss.1001-8409.2020.12.12>.
- Yang, X.Y. (2020). "Research on Risk Assessment of Green Supply Chain Finance—A comparative Study Based on Logit Model and BP Neural Network." *Journal of Industrial Technological Economics*, 39(12), 8. <https://doi.org/10.1016/j.jretai.2012.10.004>.
- Tao, K. (2021). "Research on Financing Models for Small and Medium Enterprises from the Perspective of Green Supply Chain Finance." *China Market*, (13), 13-16+20. <https://doi.org/10.13939/j.cnki.zgsc.2021.13.013>.
- Zhang, M.X., & Zhang, C. (2021). "Research on Benefit Allocation of Green Supply Chain Finance under Uncertain Demand Conditions." *Credit Reference*. <https://doi.org/10.1037/h0061470>.

Jia, Q., Wang, S., & Chen, W.X. (2023). Research on the relationship between digital job crafting, algorithm version, and job performance in the digital transformation. In Li, E.Y. et al. (Eds.) *Proceedings of The International Conference on Electronic Business, Volume 23* (pp. 526-534). ICEB'23, Chiayi, Taiwan, October 19-23, 2023

## Research on the Relationship Between Digital Job Crafting, Algorithm Aversion, and Job Performance in the Digital Transformation

Qiong Jia <sup>1,\*</sup>  
Shan Wang <sup>2</sup>  
Wenxue Chen <sup>3</sup>

\*Corresponding author

<sup>1</sup> Associate Professor, Hohai University, Nanjing, jiaqiong@163.com

<sup>2</sup> Master Degree Student, Hohai University, Nanjing, 211313040045@hhu.edu.cn

<sup>3</sup> Undergraduate Student, Hohai University, Nanjing, 1024471432@qq.com

### ABSTRACT

Digital transformation has been disrupting the management of enterprises with innovative technology, which challenges employees' adaption for the job crafting, algorithms' application. However, how such change affects employees' job performance is still uncovered. To fill this gap, according to resource conservation theory and social exchange theory, this study aims to explore the impact of digital job crafting on job insecurity and algorithm aversion, and introduce organizational support as a moderating variable to understand the path of digital job crafting to affect job performance. This study verified relevant conclusions by analyzing 242 questionnaires, and ultimately provide theoretical and practical guidance for employees to actively adapt to digital transformation and improve job performance.

*Keywords:* Digital transformation, digital job crafting, algorithm aversion, job performance.

### INTRODUCTION

With the rapid development of digital technology, the emergence of new technologies such as the Internet of Things (IoT), artificial intelligence (AI), cloud computing, and online payment systems has profoundly transformed both the internal and external environments of enterprises. Digital transformation of businesses has become a prevailing trend. It is the inevitable result of enterprise internal technological innovation, it is also the key means to drive the enterprise internal technological innovation, provides new opportunities for the sustainable development of traditional enterprises. Hence, it is essential to intensify innovation investments, continually foster a digital-savvy workforce, cultivate a digital enterprise culture, so as to enhance business performance, and facilitate corporate growth.

Although an increasing number of digital technologies have been incorporated into business operations (Chen & Benson, 2023; Nagtegaal, 2021), the widespread use of digital technologies in the workplace may cause employees to perceive algorithms differently. On the one hand, employees can swiftly embrace and proficiently utilize such algorithms to enhance work efficiency (Chowdhury et al., 2023). On the other hand, some advanced algorithms are beyond the cognitive boundaries of employees, resulting in employees unable to master and apply these algorithms. In certain instances, artificial intelligence has even replaced humans in performing basic tasks independently. The above situation aggravates employees' job insecurity, leading to aversion to algorithms, thereby generating adverse effects on work and subsequently reducing employee job performance (Cuyper et al., 2020).

The concepts of job crafting and employee job insecurity have garnered considerable attention from scholars (Buonocore et al., 2020, Hngoi et al., 2023). However, there remains a notable gap in interdisciplinary research involving the introduction of algorithm into corporate work scenarios and their impact on employee performance. Therefore, under the background of the mainstream trend of enterprise digital transformation, this study aims to study the impact of digital job crafting on job insecurity and algorithm aversion, and then understand the path of digital job crafting to improve job performance. Furthermore, employee behavior and psychology are influenced by organizational factors (Gómez, 2004), hence this research, drawing upon theories like conservation of resources theory, to examine the moderating roles of organizational support. Ultimately, by studying the relationship between digital job crafting and job performance, we explore ways to reduce the adverse effects of job insecurity and algorithm aversion that employees may have in the digital transformation of enterprises, and provide insights for enterprises that are or have not yet begun digital transformation.

### THEORY AND HYPOTHESES

#### Resource Conservation Theory

The core assumption and basic principle of resource conservation theory is that individuals have the motivation to protect their existing resources and obtain new or non-existent resources. Individuals will have pressure when existing resources have been lost and existing resources may be lost in the future. In order to reduce or eliminate pressure, individuals will try their best to

maintain and obtain resources that they think are valuable (Hobfoll, 1989). From the perspective of resource conservation, when individuals have resource depletion from work needs, it is the main internal cause of adverse effects on employees. Therefore, the conservation of resources theory can well explain why employees have negative work emotions and work behaviors, that is, when employees face digital transformation, they feel that their own resources are unbalanced, which leads to a negative reaction even low job performance. In addition, according to the theory of resource protection, when employees are supported and helped by the organization at work, they will perceive this positive energy and return it through their own efforts. In reality, employees often rely on their own intuition or habits to determine whether the algorithm is beneficial to them. The accuracy and stability of this speculative conclusion vary from person to person. In the context of the algorithm, the user's cognitive and psychological factors play a more significant role in this process, and all this depends on the employee's perception of the algorithm in the practice process.

The resource conservation theory holds that individuals with more resources can enrich their resources through value-added spirals, thus effectively preventing and responding to the invasion of stress on their own resources (Hobfoll, 1989). Therefore, when employees face digital transformation, more resources can not only help individuals resist the loss of psychological resources caused by the pressure of learning digital work skills, but also nurture a new value-added spiral, so that they can further pay attention to the long-term benefits brought by digital transformation, stimulate the internal work motivation of individuals, and even adopt deviant innovative ways to carry out work practice. Resources can generally be obtained based on two channels: internal characteristics and external environment (Woodman, 1993). At the level of individual factors, how employees respond to digital transformation depends on whether they pay attention to the positive attributes of the results. Digital job crafting refers to the process in which individuals spontaneously make substantial or cognitive changes in the characteristics of digital work tasks, interpersonal interactions, and the use of digital technology in order to match their own preferences, the use of digital technology, and the requirements of digital work (SHI et al., 2023). Digital job crafting helps employees to improve their ability to match digital work, and ultimately leads to the improvement of employees' job performance. In terms of situational factors, the organizational support provided by the organization to employees will give employees a better adaptation to the digital transformation process of the enterprise, and employees may have a more positive attitude towards digital transformation. Therefore, this study believes that organizational support may also be a key factor affecting employees' job performance in the process of digital transformation.

### **Social Exchange Theory**

The Social Exchange Theory emerged in the United States in the 1960s and was initially introduced by Homans (1974). This theory advocates drawing on concepts of input and output from economics to explore the psychological processes and behavioral outcomes of individuals in their daily work and life. All human activities, including labor, education, learning, and various other social practices, are undertaken to fulfill certain needs, which are in turn the means by which individuals pursue their professions or livelihoods. Within human behavioral norms, the principle of seeking benefits and avoiding harm is regarded as a fundamental exchange relationship, where all social activities are seen as interdependent relationships. In social life, if people want to establish a social exchange relationship with others, they must be able to bring or create the benefits needed by each other. In the exchange relationship, the two sides should follow the 'principle of reciprocity', which is also a basic principle of social exchange (Cropanzano et al., 2017). Social exchange theory has been widely applied to the study of organizational behavior and human resource management (Zhang & Jia, 2010). Therefore, social exchange theory can also be used to explain the impact of organizational support on employee performance in the process of digital transformation.

### **Model Construction**

#### ***The impact of digital job crafting***

Job crafting refers to the process in which employees actively change the task boundary and interpersonal boundary cognitively in order to make their own preferences consistent with their work (Wrzesniewski & Dutton, 2001). When employees begin to exhibit behaviors of job crafting, it indicates that their work is relatively free at this point, and they aspire to attain more resources through job crafting to achieve higher work standards, thereby elevating the significance of their work. Simultaneously, job crafting can facilitate employees' individual perception of work value, serving as a significant avenue for realizing the meaningfulness of work (Wrzesniewski et al., 2010). In addition, employees can reduce barriers to work and increase personal resources through digital job crafting so that they can better engage in their work (Bakker & Oerlemans, 2019). In the context of digital transformation of enterprises, digital job crafting refers to the process in which individuals spontaneously make substantial or cognitive changes in the characteristics of digital work tasks, interpersonal interaction and the use of digital technology in order to match their own preferences, the use of digital technology and the requirements of digital work (SHI et al., 2023). Digital job crafting can help employees better adapt to the challenges brought by digital technology. It is a bottom-up behavior initiated by employees to change the characteristics of digital work. The purpose of employees' digital job crafting is to realize the matching between individual preferences and digital job requirements and digital technology use, so as to improve job performance and actively adapt to digital transformation.

In the process of digital transformation, enterprises generally have problems such as the mismatch between employees' digital ability and digital work requirements, and the improvement speed of employees' digital ability cannot keep up with the development of digital technology (Hubschmid et al., 2020). Therefore, not all employees who are undergoing digital transformation of enterprises will have a positive impact. When employees' behavior and work content are inconsistent, it will lead to negative impact. Studies have shown that employees give full play to their subjective initiative and reshape the working

environment from bottom to top is the key link to achieve individual preference and job matching (Zhang & Parker, 2019). Therefore, when employees reshape their digital work in the process of digital transformation, they can effectively match their own capabilities with the transformation of the enterprise, thus reducing the negative effects of job insecurity and algorithm aversion brought by digital transformation. Therefore, this paper puts forward the hypotheses:

H1: Digital job crafting has a positive impact on job performance.

H2: Digital job crafting has a negative impact on job insecurity.

H3: Digital job crafting has a negative impact on algorithm aversion.

### ***The Impact of Job Insecurity and Algorithmic Aversion***

Job insecurity pertains to employees' perceptions and emotional experiences regarding the possibility of losing their job or the continuity of their job (Näswall et al., 2005). It reflects individuals' perception of uncertainty regarding the continuity of their work, which can lead employees to feel that their capabilities are unrecognized or are on the verge of being replaced. In the digital enterprise environment, an increasing number of novel algorithms are being introduced, motivating employees to engage in job crafting behaviors. However, not everyone is receptive to integrating technology into their work. Some advanced algorithms might surpass employees' cognitive boundaries, making them unable to comprehend or operate these algorithms. Moreover, certain artificial intelligence systems have even started to replace humans in performing fundamental tasks, which can induce stress, anxiety, and a sense of job insecurity among employees.

The changes brought about by digital technology are characterized by high levels of uncertainty. Faced with the unknown, individuals tend to feel fear and stress. Employees might worry about whether these technologies will threaten their jobs or replace their roles. According to resource conservation theory, such negative emotions can persist and adversely affect their work status. The resulting sense of insecurity impedes career development, leading to reduced commitment to work, decreased job satisfaction, and subsequently influencing job performance levels (Piccoli et al., 2021). In the process of digital transformation, digital technologies become indispensable tools in employees' work. However, the underlying principles of algorithms are often intricate, and even if provided, employees who lack relevant algorithmic knowledge need substantial time to learn and apply them. Once algorithm aversion takes root, it does not necessarily contribute to enhancing job performance. Consequently, the digital transformation environment, along with the complexities and rapid iterations of algorithms, exacerbates employees' algorithm aversion, as they feel the pressure of having to rapidly learn these technologies to avoid becoming obsolete in the future. The resulting algorithm aversion reduces the positive impact of enterprise digital transformation and brings negative effects such as reduced job performance. The following hypotheses are proposed in this study:

H4: Job insecurity has a negative impact on job performance.

H5: Algorithm aversion has a negative impact on job performance.

H6: Job insecurity and algorithm aversion play a chain mediating role in digital job crafting and employee performance.

### **Moderating Role of Organizational Support**

Prior research has shown that individual and organizational factors significantly influence employee performance (Setiawan & Adji, 2022). For individuals, digital transformation promotes the change of organizational operation mode, puts forward higher requirements for employees' digital knowledge and skills, and leads to the loss of individual psychological resources. Faced with the loss of resources, individuals will tend to save resources and expect to obtain more resources (Hobfoll, 2011). For organizations, although digital job crafting is a bottom-up proactive behavior of employees, because the digital job tasks of employee crafting are nested in the organizational context, the organizational context (e.g., colleagues, leadership and organizational characteristics) related to digitization may affect the positive role of digital job crafting. If employees can acquire support from the organization in the period of the digital transformation of the organization, there are more organizational resources to better cope with the pressure brought by digital transformation and form a new value-added spiral. Therefore, employees will turn from worrying about digital transformation to paying attention to the long-term benefits brought by digital transformation, and constantly break through the bottleneck in their work, so as to be confident in their own development and promote the activation of the benefits brought by digital job crafting. At the same time, the support from the organization also helps employees to clarify the organizational requirements of digitalization, deeply reflect on the digital work skills of the target individual, and then produce more obvious digital work crafting behavior to improve job performance. Therefore, the hypothesis is put forward:

H7: Organizational support moderates the relationship between the digital job crafting and job performance.

Social psychologist Eisenberger et al. (1986) contends that the notion of organizational support perception refers to employees' overall perception and belief in how the organization views their contributions and cares about their interests. Grounded in attribution theory, when individuals perceive support and assistance from the organization, they become immersed in a positive emotional experience, which can stimulate their intrinsic motivation and emotional resonance. In essence, employees experience

emotional resonance from the organizational level and are willing to contribute to it. In the actual work scenario, some employees are not opposed to using the algorithm in essence, but they have not used it before and do not understand the relevant advantages.

In addition, they are also worried about the irreversible consequences of errors or omissions caused by using the algorithm. Although algorithms exhibit high precision and credibility in certain domains, when facing significant decisions, employees may bear the consequences of algorithmic outcomes. As a result, they may prefer to stick to traditional methods rather than risk the potential hazards of using algorithms. According to resource conservation theory and social exchange theory, when employees are supported and helped by the organization in their work, such as work training, algorithm guidance, artificial care and other positive resources, employees tend to reduce algorithm aversion to invest in creating higher resources, such as improving job performance (Liu et al., 2021). In addition, when employees are supported by the organization, in order to establish a social exchange relationship with the organization, employees will create greater value for the organization by reducing their aversion to algorithms (Li, 2015). Thus, if organizations provide certain training to employees, introduce the benefits of algorithms, or provide examples of successful outcomes derived from the algorithm use, and so on, these efforts can significantly alleviate employees' aversion to algorithms. By guiding employees rationally through algorithmic activities and mitigating the potential adverse consequences of algorithms, organizations can reduce employees' insecurity and algorithm aversion, thereby enhancing work performance. Based on these considerations, the following hypotheses are proposed:

H8: Organizational support moderates the relationship between the digital job crafting and job insecurity.

H9: Organizational support moderates the relationship between the digital job crafting and algorithm aversion.

Building upon the aforementioned hypothesis, the model of this study is depicted in Figure 1 as shown:

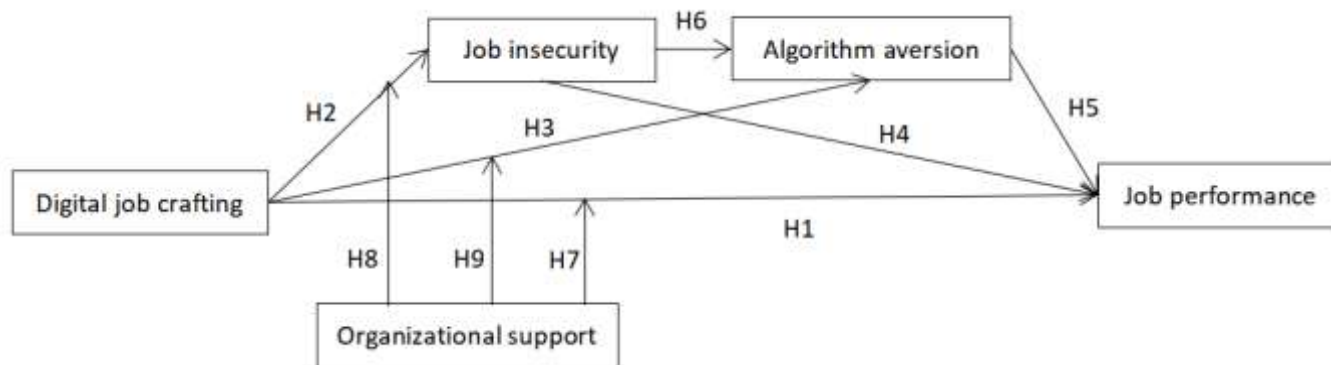

Figure 1: Research model.

## METHODOLOGY

### Data Collection

The study focuses on employees in the context of digital transformation, without restricting the industry or nature of the enterprises. The research employed online questionnaires as the primary data collection method and conducted in-person interviews with individuals who had substantial work experience. The questionnaires were rated based on participants' genuine feelings and attitudes toward hypothetical scenarios in their work. Established scales were utilized in the questionnaire design, and a five-point Likert-type scale was employed for measurement, ranging from 1 ("Strongly Disagree") to 5 ("Strongly Agree"). A total of 260 questionnaires were collected, with invalid ones excluded, resulting in 242 valid responses for data analysis in this study. The demographic profile of the respondents is presented in Table 1. It can be seen that the proportion of male and female surveyed is balanced. Nearly half of the respondents are between 33-43 years old (45.5 %). Employees of this age group are generally between young people who are accustomed to the digital age and older people who are not very good at accepting digital transformation, which has a good explanatory significance. In addition, the industry, work seniority and computer information technology level of the respondents are evenly distributed.

Table 1: Demographic profile of the respondents.

items	options	frequency	percent	mean	standard deviation
sex	male	103	42.6	1.57	0.495
	female	139	57.4		
age	under 32 years old	53	21.9	2.2	0.89
	33-43 years old	110	45.5		
	44-54 years old	56	23.1		
	over 54 years old	23	9.5		
degree	high school and below	35	14.5	2.47	0.884

	junior college	87	36		
	undergraduate	91	37.6		
	master degree or above	29	12		
industry	Internet industry	35	14.5	2.65	1.083
	manufacturing industry	81	33.5		
	banking industry	71	29.3		
	education and entertainment	43	17.8		
	others	12	5		
nature of enterprise	state-owned enterprise	54	22.3	2.24	0.957
	private enterprise	104	43		
	foreign capital or joint venture	60	24.8		
	public institution or government department	19	7.9		
	others	5	2.1		
rank	ordinary staff	106	43.8	1.94	0.986
	junior management	64	26.4		
	middle management	53	21.9		
	top management	19	7.9		
work seniority	0-5 years	59	24.4	2.36	1.042
	6-10 years	81	33.5		
	11-15 years	58	24		
	15 years or more	44	18.2		
computer information technology level	proficient in using many software	45	18.6	2.54	1.011
	proficient in basic office software	70	28.9		
	know and can use 1-2 software easily	79	32.6		
	I don't use any software at all	48	19.8		

## Data Analysis

### Reliability and Validity Analysis

When processing data and testing hypotheses, reliability reflects the questionnaire's effectiveness and indicates the stability of the measurement results. In this study, the Cronbach's  $\alpha$  coefficient was used for reliability analysis. Generally, when Cronbach's  $\alpha > 0.7$ , it indicates good overall reliability of the scale. As shown in Table 2, the reliability coefficient values of the research data are consistently above 0.7, indicating high-quality data reliability of the scale and providing substantial support for subsequent analyses.

Table 2: Reliability analysis.

Items	Number of items	Cronbach' $\alpha$
Digital job crafting	6	0.774
Job insecurity	4	0.786
Algorithm aversion	5	0.724
Job performance	8	0.872
Organizational support	4	0.796
All items	35	0.896

Utilizing SPSS 26.0, an analysis of the validity of the relevant data was conducted, followed by the derivation of the Kaiser-Meyer-Olkin (KMO) values for each variable, as presented in Table 3. The KMO values for this study are all above 0.6, indicating that the data can be effectively extracted.

Table 3: Validity analysis.

Items	Number of items	KMO
-------	-----------------	-----

Digital job crafting	6	0.836
Job insecurity	4	0.693
Algorithm aversion	5	0.799
Job performance	8	0.785
Organizational support	4	0.900
All items	35	0.878

**Common Method Deviation Test and Multicollinearity Test**

We used Harman's single factor analysis method to test the common method deviation. The results indicated that the variance of the first principal component explanation, without rotation, was 31.239%. Therefore, the common method deviation for this study is not significant. To further evaluate for multicollinearity, we calculated the variance inflation factor (VIF). The results showed that the VIF values ranged from 1.139 to 1.898, all well below the threshold of 10. This finding suggests that multicollinearity is not a significant issue in this study.

**Hypothesis Test**

**Correlation Analysis**

Table 4 displays the findings of a statistical analysis of the correlation of variables. The results support H1, H2, H3, H4 and H5.

Table 4: Correlation analysis.

	M	SD	Digital job crafting	Job insecurity	Algorithm aversion	Organizational support	Job performance
Digital job crafting	3.353	0.668	1				
Job insecurity	3.313	0.919	-0.461**	1			
Algorithm aversion	3.074	0.760	-0.332**	0.018*	1		
Organizational support	3.712	0.839	0.601**	-0.375**	-0.129*	1	
Job performance	3.702	0.765	0.645**	-0.382**	-0.151*	0.691**	1

Note: \*  $p < 0.05$  \*\*  $p < 0.01$

**Mediation Test**

We used process for mediation analysis. The results are shown in Table 5. For digital job crafting → job insecurity → job performance path, the interval does not include the number 0 (95 % CI: 0.022 ~ 0.086). For digital job crafting → algorithm aversion → job performance path, the interval does not include the number 0 (95 % CI: 0.062 ~ 0.019). According to the analysis of the chain mediating effect path, the interval includes the number 0 (95 % CI: 0.017 ~ 0.007) in the path of job crafting → job insecurity → algorithm aversion → job performance. The results support hypothesis 6.

Table 5: Mediating effect analysis.

	Effect	SE	LCI	UCL
Direct Effect				
Digital job crafting → Job performance	0.645	0.067	0.917	0.612
Indirect Effects (Bootstrapped)				
Total	0.408	0.033	0.058	0.073
Digital job crafting → Job insecurity → Job performance	0.129	0.027	0.022	0.086
Digital job crafting → Algorithm aversion → Job performance	0.216	0.020	0.062	0.019
Digital job crafting → Job insecurity → Algorithm aversion → Job performance	0.063	0.006	0.017	0.007



### Moderation Test

As shown in Figure 6, the interaction items of digital job crafting and organizational support have significant positive effects, that is, organizational support moderates the relationships between digital job crafting and job performance, digital job crafting and job insecurity, and digital job crafting and algorithm aversion respectively. The results support hypothesis 7,8 and 9.

Table 6: Moderating effect analysis.

	Job performance as DV		Job insecurity as DV		Algorithm aversion as DV	
constant	2.898(0.062)**	2.992(0.064)**	2.582(0.060)	3.722(0.063)**	2.807(0.037)***	2.930(0.069)*
Digital job crafting	0.647(0.193)***	0.691(0.192)**	-0.467(0.065)***	-0.422(0.096)*	-0.378(0.069)***	-0.313(0.096)**
Digital job crafting*Organizational support		0.079(0.051)*		0.058(0.068)**		0.103(0.072)***
R <sup>2</sup>	0.316	0.380	0.175	0.310	0.110	0.327
Adjusted R <sup>2</sup>	0.413	0.370	0.172	0.303	0.106	0.316
F	17.654, p=0.000	20.970, p=0.05	15.011, p=0.000	14.783,p=0.01	16.783, p=0.000	11.543, p=0.000
ΔR <sup>2</sup>	0.057	0.380	0.007	0.030	0.018	0.021

## DISCUSSION

### Discussion on Results

This paper focuses on the context of digital transformation in enterprises and combines the theoretical frameworks of resource conservation and social exchange theories. With employees as the research subjects, regression analysis was employed to explore the relationships among several key variables, the results are shown below.

First of all, digital job crafting has a positive impact on job performance. Under the background of digital transformation, enterprise technology empowerment can be promoted. The new operation mode of enterprises puts forward higher requirements for employees' digital business skills, and employees' individual psychological resources are depleted. According to the theory of resource conservation, individuals have the tendency to preserve resources from loss. In this situation, employees reduce the probability of future resource damage through digital job crafting composed of new work nature, work style, work relationship and other elements spontaneously generated by digital technology, so as to improve work performance.

Secondly, job insecurity and algorithm aversion play a mediating role in digital job crafting and job performance. Through digital job crafting, employees adapt to the new working mode and break the unknown brought by digital transformation. Therefore, digital job crafting improves job performance by reducing job insecurity and algorithm aversion.

Finally, organizational support plays a moderating role in the whole process of digital job crafting to job performance. Organizational support, an organizational resource, buffers the pressure and aversion brought by the digital transformation of enterprises to employees. It not only encourages employees to respond to digital transformation with a more positive attitude, but also helps employees to promote the induction of digital job crafting behavior, thereby improving employee performance.

### Theoretical Implications

The concepts of job crafting and employee job performance have garnered attention from scholars both domestically and internationally. However, the research on the application of the two to the process of digital transformation is extremely lacking. This study constructs a research model from the perspective of resource conservation theory, and empirically tests the role of digital job crafting in improving job performance under the background of digital transformation, which enriches relevant research. In addition, the results show that higher organizational support promotes the positive effect of digital job crafting on job performance, which shows that organizational factors play an important role in the process of digital transformation, and enriches the research on the impact of organization on individual utility.

### Managerial Implications

By exploring the relationship between digital job crafting and job performance, and discussing the moderating role of organizational support, this study provides insights for companies currently undergoing or planning digital transformation to solve the job insecurity and algorithmic aversion that may be brought to employees during the digital transformation of enterprises. Enterprises can start from two aspects of personal factors and organizational factors to reduce the adverse effects of digital transformation.

## Limitations and Future Research

Firstly, all variables in this study were measured using self-assessment questionnaires, which inherently carry some bias. Future research could employ methods like interviews and on-site investigations for data collection. Secondly, while this paper may demonstrate the relationships between digital job crafting and job performance, the relationship between algorithm aversion and job performance can be further investigated. At present, systematic research on the relationship between employees' use of algorithms, attitudes towards algorithms, and job performance in the workplace is lacking in academia. This paper presents a new direction for future research. Thirdly, Future research can explore the influencing factors of job performance in the digital transformation from all aspects of internal and external factors such as the age of employee, nature of the company, industry background and so on. Lastly, future research could conduct longitudinal studies on participants to observe the dynamic changes in variables over time and gain a more comprehensive understanding of the impact of digital job crafting and organizational support in digital transformation in an all-round way.

## ACKNOWLEDGMENT

Generous financial support was provided by the Ministry of Education's Industry-Academic-Research Collaborative Education Project (No. 822145016), and Fundamental Research Funds for the Central Universities [No. B210207008].

## REFERENCES

- Bakker, A. B., & Oerlemans, W. G. (2019). Daily job crafting and momentary work engagement: A self-determination and self-regulation perspective. *Journal of Vocational Behavior*, 112, 417-430. <https://doi.org/10.1016/j.jvb.2018.12.005>
- Buonocore, F., de Gennaro, D., Russo, M., & Salvatore, D. (2020). Cognitive job crafting: A possible response to increasing job insecurity and declining professional prestige. *Human Resource Management Journal*, 30(2), 244-259. <https://doi.org/10.1111/1748-8583.12270>
- Chen, D., & Benson, G. (2023). Artificial Intelligence (AI) in Employee Selection: How Algorithm-based Decision Aids Influence Dec. *Academy of Management*, 2023(1):17951. <https://doi.org/10.5465/AMPROC.2023.170bp>
- Cropanzano, R., Anthony, E. L., Daniels, S. R., & Hall, A. V. (2017). Social exchange theory: A critical review with theoretical remedies. *Academy of management annals*, 11(1), 479-516. <https://doi.org/10.5465/annals.2015.0099>
- Chowdhury, S., Dey, P., Joel-Edgar, S., Bhattacharya, S., Rodriguez-Espindola, O., Abadie, A., & Truong, L. (2023). Unlocking the value of artificial intelligence in human resource management through AI capability framework. *Human Resource Management Review*, 33(1), 100899. <https://doi.org/10.1016/j.hrmr.2022.100899>
- De Cuyper, N., Schreurs, B., De Witte, H., & Selenko, E. (2020). Impact of job insecurity on job performance introduction. *Career Development International*, 25(3), 221-228. <https://doi.org/10.1108/CDI-06-2020-332>
- Eisenberger, R., Huntington, R., Hutchison, S., & Sowa, D. (1986). Perceived Organizational Support. *Journal of Applied Psychology*, 71(3), 500-507. <https://doi.org/10.1037/0021-9010.71.3.500>
- Gómez, C. (2004). The influence of environmental, organizational, and HRM factors on employee behaviors in subsidiaries: a Mexican case study of organizational learning. *Journal of World Business*, 39(1), 1-11. <https://doi.org/10.1016/j.jwb.2003.08.006>
- Hngoi, C. L., Abdullah, N.-A., Wan Sulaiman, W. S., & Zaiedy Nor, N. I. (2023). Relationship between job involvement, perceived organizational support, and organizational commitment with job insecurity: A systematic literature review. *Frontiers in Psychology*, 13, 1066734. <https://doi.org/10.3389/fpsyg.2022.1066734>
- Hobfoll, S. E. (1989). Conservation of resources: A new attempt at conceptualizing stress. *American psychologist*, 44(3), 513. <https://doi.org/10.1037/0003-066X.44.3.513>
- Hobfoll, S. E. (2011). Conservation of resource caravans and engaged settings. *Journal of occupational and organizational psychology*, 84(1), 116-122. <https://doi.org/10.1111/j.2044-8325.2010.02016.x>
- Homans, G. C. (1974). Social Behavior: Its Elementary Forms.
- Hubschmid-Vierheilg, E., Rohrer, M., & Mitsakis, F. (2020). Digital competence revolution and human resource development in the United Kingdom and Switzerland. *The Future of HRD, Volume I: Innovation and Technology*, 53-91. [https://doi.org/10.1007/978-3-030-52410-4\\_3](https://doi.org/10.1007/978-3-030-52410-4_3)
- Li, J. (2015). The mediating roles of job crafting and thriving in the LMX-employee outcomes relationship. *Japanese Journal of Administrative Science*, 28(1), 39-51. <https://doi.org/10.5651/jaas.28.39>
- Liu, L., Wan, W., & Fan, Q. (2021). How and when telework improves job performance during COVID-19? Job crafting as mediator and performance goal orientation as moderator. *Psychology Research and Behavior Management*, 14, 2181-2195. <https://doi.org/10.2147/PRBM.S340322>
- Lu, C.-q., Wang, H.-j., Lu, J.-j., Du, D.-y., & Bakker, A. B. (2014). Does work engagement increase person-job fit? The role of job crafting and job insecurity. *Journal of vocational behavior*, 84(2), 142-152. <https://doi.org/10.1016/j.jvb.2013.12.004>
- Mahmud, H., Islam, A. N., Ahmed, S. I., & Smolander, K. (2022). What influences algorithmic decision-making? A systematic literature review on algorithm aversion. *Technological Forecasting and Social Change*, 175, 121390. <https://doi.org/10.1016/j.techfore.2021.121390>
- Nagtegaal, R. (2021). The impact of using algorithms for managerial decisions on public employees' procedural justice. *Government Information Quarterly*, 38(1), 101536. <https://doi.org/10.1016/j.giq.2020.101536>
- Näswall, K., Sverke, M., & Hellgren, J. (2005). The moderating effects of work-based and non-work based support on the relation between job insecurity and subsequent strain. *SA Journal of Industrial Psychology*, 31(4). <https://hdl.handle.net/10520/EJC89066>

- Piccoli, B., Reisel, W. D., & De Witte, H. (2021). Understanding the relationship between job insecurity and performance: hindrance or challenge effect? *Journal of Career Development*, 48(2), 150-165. <https://doi.org/10.1177/089484531983318>
- Setiawan, A. A., & Adj, K. (2022). The Effect of Career Development, Organizational Commitment, and Work Motivation on Employee Performance. *Indonesian Journal of Law and Economics Review*, 17, 10-21070. <https://doi.org/10.21070/ijler.v17i0.804>
- SHI, Y., XIE, J., WANG, Y., & ZHAGN, N. (2023). Digital job crafting and its positive impact on job performance: The perspective of individual-task-technology fit. *Advances in Psychological Science*, 31(7), <https://doi.org/1133.10.3724/SP.J.1042.2023.01133>
- Wrzesniewski, A., Berg, J. M., & Dutton, J. E. (2010). Managing yourself: Turn the job you have into the job you want. *Harvard business review*, 88(6), 114-117. <https://doi.org/10.1016/j.jmacro.2006.12.002>
- Wrzesniewski, A., & Dutton, J. E. (2001). Crafting a job: Revisioning employees as active crafters of their work. *Academy of management review*, 26(2), 179-201. <https://doi.org/10.5465/amr.2001.4378011>
- Woodman, R. W., Sawyer, J. E., & Griffin, R. W. (1993). Toward a theory of organizational creativity. *Academy of management review*, 18(2), 293-321. <https://doi.org/10.5465/amr.1993.3997517>
- Zhang, F., & Parker, S. K. (2019). Reorienting job crafting research: A hierarchical structure of job crafting concepts and integrative review. *Journal of organizational behavior*, 40(2), 126-146. <https://doi.org/10.1002/job.2332>
- Zhang, Z., & Jia, M. (2010). Using social exchange theory to predict the effects of high-performance human resource practices on Corporate Entrepreneurship: Evidence from China. *Human Resource Management*, 49(4), 743-765. <https://doi.org/10.1080/1471903042000339392>

## Retrospective Analysis of Natural Disaster Impact on Firm Growth: A Case in Manufacturing Firms in Bangladesh

A.B.M. Munibur Rahman <sup>1,\*</sup>  
Mohammad Abir Shahid Chowdhury <sup>2</sup>  
Zhan Zhan <sup>3</sup>  
Arnab Paul <sup>4</sup>

\*Corresponding author

<sup>1</sup> Business School, Wuchang University of Technology, Wuhan, P.R. China. abmmrahman@wut.edu.cn

<sup>2</sup> School of Economics and Management, China University of Geosciences, Wuhan, PR China. abir.shahid@cug.edu.cn

<sup>3</sup> Business School, Wuchang University of Technology, Wuhan, PR China. robbiezhan@hotmail.com

<sup>4</sup> Business School, Wuchang University of Technology, Wuhan, PR China. parnab51@gmail.com

### ABSTRACT

Natural disaster has vulnerable effects on manufacturing firm's growth as well as on economic development, due to climate change in these geographical areas. The limited empirical evidence in this knowledge base points out inappropriate strategic policy decisions for manufacturing firms' growth in developing countries as root cause. Taking manufacturing firms in Bangladesh as an example, this paper upholds the impact of natural disasters on firm growth in both short and long run. The estimates use the World Bank Enterprise Survey (WBES) Data as a sample to analyze firm growth between 2007 and 2014 in Bangladesh matched with Emergency Event Database (EM-DAT) disaster database for 2472 valid samples of manufacturing firms using the OLS regression model. The study finds the positive association of natural disasters with long term growth measured via assets and labor growth. Whereas the study found that the natural disasters negatively short run firm growth measured via sales growth. We may also conclude that natural disasters significantly impact on firm growth and policymakers can initiate the strategies for manufacturing firms to mitigate the risk of climate change.

*Keywords:* Natural disaster, Firm growth, Climate Change, Manufacturing Companies.

### INTRODUCTION

The natural disaster has become a compelled globally discussed topic over the past few decades throughout the world. The intrinsic catastrophic and rowdy nature of natural disasters may draw severe losses on firm/economic growth. The disaster theory even though remains indecisive, having mere systematic evidence on how natural disasters affect firm growth (Eduardo Cavallo, Galiani, Noy, & Pantano, 2013; FIALA., Fiala, & Fess, 2017; Noy & duPont IV, 2016).

Due to geographical location, Bangladesh is one of the major deltas in the globe and is heavily vulnerable to natural disasters and as an example, throughout the rainy season, Bangladesh is inclined to flooding (Hee, Kalimuthu, Yu, Pong, & Chew, 2018). It is mandatory to get a clear understanding of the relationship between economic activities and natural disasters in order to cope with climate changes and to improve precaution and resilience for the short and long run.

The impact of natural disasters can be categorized as indirect impacts such as property or asset losses and indirect economic impacts, like effects on economic growth or firm growth (E Cavallo & Noy, 2009). Literature (Eduardo Cavallo et al., 2013; Fomby, Ikeda, & Loayza, 2009; Loayza, Olaberria, Rigolini, & Christiaensen, 2012; Noy, 2009; Skidmore & Toya, 2002; Strobl, 2012) has explored short-run and long-run effects of environmental disasters on the economy or firm growth and their findings showed that positive or negative impact on the economy, depending on multi types of dimensions including disasters such as floods typhoons. The prior is quite well understood, whereas understanding natural disaster impact on firm or economic growth is quite indefinite (Lazzaroni & van Bergeijk, 2014). It is crucial to count the indirect losses to figure out the consequences of natural disasters on the assets (Hallegatte & Przulski, 2010). Nonetheless, disaster impact evidence on economic growth is quite inconclusive and almost gathered country wise or regional level accumulated macroeconomic data (Klomp & Valckx, 2014; Lazzaroni & van Bergeijk, 2014).

This inconsistency in the results is partly related to the lack of full consideration of differences in terms of disaster types, locations, economic and financial development, institutional quality, the time period used for analysis, definitions of disaster costs, and valuation methodologies (Eduardo Cavallo et al., 2013; Felbermayr & Gröschl, 2014; Loayza et al., 2012). To date, there is limited evidence on the micro-level relationship between firm activities and natural disasters to gain a better understanding of how the economic growth got affected by natural disaster (Cole, Elliott, Okubo, & Strobl, 2017; Leiter, Oberhofer, & Raschky, 2009; Tanaka, 2015).

Therefore, the current study investigates natural disasters' impact on firm growth in both the short and long run using firm-level data of Bangladesh for the period between 2007 and 2014. The model is estimated by using Ordinary least square (OLS) to explore the effect of disaster measures on the firms growth while measuring disaster with number of deaths and number of affected individuals. On average, we find similar positive impacts of natural disasters for both of its measures.

In this paper, section 2 presents the theoretical background and hypothesis; section 3 describes the methodology and outline of the empirical framework. Later discussing our outcomes in section 4, we conclude this article in section 5.

### **Theoretical Background & Hypothesis**

Most of the available literature on the impact of natural disasters has intended to concentrate on firm-level growth effects and the output has been rather mixed. Here we exhibit how sales growth, asset growth, and labor growth are affected by a natural disaster comparable to (Leiter et al., 2009; Tanaka, 2015). According to (Lazzaroni & van Bergeijk, 2014), there is a negative direct impact of the disaster on direct cost and show consistency in the results. The researcher (Kahn, 2005) mentioned the physical intensity and nature of the natural disaster is related to the direct cost size as well as quasi disaster prevention management such as evacuation plans, prevention measures in the area, and early warning systems. During post-disaster when equity is revised with updated efficient technologies which are known as creative destruction, the author said we may find a positive effect on long-run firm growth (Leiter et al., 2009). (Skidmore & Toya, 2002) assume that labor growth can be increased after the natural disaster to alternate due to the absence of physical capital, which leads to growth and hereafter raises physical capital investment. The author reveals there were persistent and significant wage premia due to sartorial workers' migration in construction and agriculture fields in Indonesia after an earthquake. But if migration occurs out of disaster-affected areas, there can be a declining curve in labor growth (Belasen & Polachek, 2009). However, labor growth can be reduced in the long run in a low-income economy after natural disaster shocks (Baez, la Fuente, & Santos, 2010; Cuaresma, 2010; McDermott, 2012). Furthermore, the symbol and magnitude of the indirect costs involved depending on the nature and physical intensity of the disasters and on the macroeconomic resilience of a society (Noy, 2009). The latter depends on several economic, social, and political characteristics, such as the level of economic development, the development of financial markets, the quality of education, the level of education, trade openness, and so on (Anbarci, Escaleras, & Register, 2005; E Cavallo & Noy, 2009; Noy, 2009; Raschky, 2008; Toya & Skidmore, 2007).

(Strobl, 2011) applies differences in the US hurricane impacts on the coastal provinces, and found that the negative impacts on growth at the county level, but beyond the county level did not affect. Noy & Vu (2010) use the data to assess the Vietnam disaster, as well as the macroeconomic positions that the disaster will find more support and destroy the asset and capital will appear as a surge, in short, increasing disaster fatalities and decreased productivity. (Rodriguez-Oreggia, De La Fuente, De La Torre, & Moreno, 2013) employ municipal data of Mexico and reveal that ordinary shocks, particularly drought and floods, lead to significant drops in the social and human development indicators in the poverty level.

(Carvalho, Nirei, Saito, & Tahbaz-Salehi, 2016) add a mechanism named systematic assessment of the aspect of output-input linkages for dissemination and augmentation of natural disasters and discover that there is a 1.2 percent fall in gross output due to the shock propagation over output-input linkages in the consecutive year of 2011 Great East Earthquake in Japan.

There are little studies on firm survival and growth after the post-disaster effect. As an example, (Leiter et al., 2009) uses Europe (AMADEUS) firm-level data to analyze flood impact on firm growth in the short run. They observe that firms affected by natural disaster or flood have inclining growth of employment and total assets compare to firms not hit by the flood. The positive imprint prevails for firms with a larger portion of intangible assets such as patents, R&D, trademarks, etc., which are less divulge to flood than tangible assets. How they find a negative flood effect for firms productivity that fall with an inclining portion of intangible assets. The debate on intangible assets as an outcome of R&D parts and may play a role as a catalyst/multiplier promoting positive (negative) nature. Besides, considering capital structure, financial strength or access to finance also plays an important role in microenterprises or small firms for post-disaster recovery (De Mel, McKenzie, & Woodruff, 2012; Runyan, 2006; Webb, Tierney, & Dahlhamer, 2002).

Both (Cole, Elliott, Okubo, & Strobl, 2013; Tanaka, 2015) interpret the Kobe earthquake impact on firm growth and survival and show supportive logic against the creative destruction hypothesis. (Tanaka, 2015) says, lower employment and value-added growth can be found in surviving firms than firms in unaffected regions during the consecutive three annual periods of the Kobe earthquake. (Cole et al., 2013) make a benchmark of damages incurred by individual landmarks and exhibit that damages done by the Kobe earthquake increase the probability of market exit for firms to reduce value-added and employment with characteristics of small, unproductive, young and recruit low-skilled labors, but surviving firms temporarily increase productivity; and boosts the establishment of new firms in severely damaged regions.

Similar to (Cole et al., 2013; Leiter et al., 2009; Tanaka, 2015), his article aims to discover natural disaster impact on firm growth. Based on the aforementioned discussion, we can hypothesize that;

H1: Natural disasters do have significant impact on short run firm growth.

H2: Natural disasters do have significant impact on long run firm growth.

## DATA AND METHODS

### Data Collection

We use the World Bank Enterprise Survey (WBES) Data as a sample to analyze firm growth between 2007 and 2014 from Bangladesh then we matched this with Emergency Event Database (EM-DAT) disaster database. Finally, we managed 2472 valid samples of manufacturing firms which contain information on sales, asset, labor and so on using WBES data source. In addition, we got data for Total deaths and the Total number of individuals affected by a natural disaster in Bangladesh by using EM-DAT.

### Measurement of the Main variables

Sales growth, asset growth, and labor growth are used as factors to measure firm growth. Labor or employment as a growth factor may contain fewer measurement errors generated by deflators, compared to sales and asset or capital. Considering short and long-term changes in the firm, sales growth can be the best indicator. Having a large portion of intangible assets there may be some problems for firms to accumulate assets or capital. Using labor as a size measure supports comparison across firms.

To analyze the impact of natural disasters on firm growth, we consider storms and floods as these two are the most common and catastrophic natural disasters in Bangladesh, accounting for the higher proportion of death tolls and the number of affected people by using EM-DAT. Storms and floods are generally regular and are more predictable than the earthquakes in Bangladesh.

Table 1: Definition of Variables

Variable	Definition	Source
Dependent Variables		
Sale Growth	Percentage growth in sales	WBES
Asset Growth	Percentage growth in assets	WBES
Labor Growth	Percentage growth in assets	WBES
Independent Variables		
Total Deaths	Total deaths in natural disaster	EM-DAT
Affected Individuals	Total number of individual affected from natural disaster	EM-DAT
Control Variables		
Firm Size (Small)	Dummy variable, equals to 1 if the firm is small and 0 otherwise.	WBES
Firm Size (Medium)	Dummy variable, equals to 1 if the firm is large and 0 otherwise.	WBES
Firm Size (Large)	Dummy variable, equals to 1 if the firm is large and 0 otherwise.	WBES
Firm Legal Status (Sole Proprietorship)	Dummy variable, equals to 1 if firm is sole proprietorship and 0 otherwise.	WBES
Firm Legal Status (Partnership)	Dummy variable, equals to 1 if firm is partnership and 0 otherwise.	WBES
Firm Legal Status (Company)	Dummy variable, equals to 1 if firm is a company and 0 otherwise.	WBES
Firm Ownership Status (Domestic)	Dummy variable, equals to 1 if major shares are owned by domestic individuals, companies or organizations, and 0 otherwise.	WBES
Firm Ownership Status (Foreign)	Dummy variable, equals to 1 if major shares are owned by foreign individuals, companies or organizations, and 0 otherwise.	WBES
Firm Ownership Status (Government)	Dummy variable, equals to 1 if major shares are owned by government and 0 otherwise.	WBES
Firm Age	Year of the survey - year of incorporation	WBES
Managerial Experience	Top manager's working experience (year)	WBES

Source: Authors' creation

Other factors also impact firm growth rather than natural disaster which include firm age, firm size, firm ownership, and some firm-specific variables (Coad, 2007) these are used as controls of the study. Gibrat's law explains that firm growth does not depend on firm size. On the other side, there is a positive correlation found between firm growth and firm age for Danish firms

during 1990 and 2004 (Bentzen, Madsen, & Smith, 2012). For firm age, (Coad, 2007) mentioned that old firms grow slower than young firms in general.

### Model Design

This study applies an ordinary least square (OLS) regression model bound examining to determine the impact of disaster measured via total death and total affected people on sales, assets, and labor growth consecutively. Moreover, as per the nature of the dataset, we also incorporate year fixed effects in our empirical models.

Firstly, the quantitative technique was applied to figure out the impact of total death on sales, assets, and labor respectively. If in equation 1-3 is positive and significant, it tells that total death has a significantly positive effect on firm growth, when other constant variables remain unchanged.

$$\text{SalesGrowth}_i = \beta_0 + \beta_1 \text{TotalDeaths}_k + \sum_{j=1}^8 \beta_j \text{ControlVariables}_{ik} + \varepsilon_{itk} \quad (\text{Equation 1})$$

$$\text{AssetsGrowth}_i = \beta_0 + \beta_1 \text{TotalDeaths}_k + \sum_{j=1}^8 \beta_j \text{ControlVariables}_{ik} + \varepsilon_{itk} \quad (\text{Equation 2})$$

$$\text{LaborGrowth}_i = \beta_0 + \beta_1 \text{TotalDeaths}_k + \sum_{j=1}^8 \beta_j \text{ControlVariables}_{ik} + \varepsilon_{itk} \quad (\text{Equation 3})$$

Similarly, we can check total affected impact on firm growth in equation 4-6.

$$\text{SalesGrowth}_i = \beta_0 + \beta_1 \text{TotalAffected}_k + \sum_{j=1}^8 \beta_j \text{ControlVariables}_{ik} + \varepsilon_{itk} \quad (\text{Equation 4})$$

$$\text{AssetsGrowth}_i = \beta_0 + \beta_1 \text{TotalAffected}_k + \sum_{j=1}^8 \beta_j \text{ControlVariables}_{ik} + \varepsilon_{itk} \quad (\text{Equation 5})$$

$$\text{LaborGrowth}_i = \beta_0 + \beta_1 \text{TotalAffected}_k + \sum_{j=1}^8 \beta_j \text{ControlVariables}_{ik} + \varepsilon_{itk} \quad (\text{Equation 6})$$

In the above equations,  $\beta_0$  is the equation constant value, where  $\beta_1$  and  $\beta_j$  represent the coefficient values, and  $\varepsilon_{itk}$  is residual value having other undetermined effects.

## EMPIRICAL RESULTS

In Table 2, we postulate the sample decomposition of our variables concerning the total number of observations, their mean, and standard deviation, minimum and maximum values. Particularly, we have chosen 2472 manufacturing companies in Bangladesh. The difference between the maximum and minimum values of sales growth is very large where one is -90.62 and 98.88, respectively. The standard deviation of sales growth is greater than its mean, where the standard deviation of labor growth is closer to its mean, 24.43. The standard deviation of values of sales growth and labor growth indicates that the companies are not similar because of a different kind of manufacturing company's sample.

Table 2: Summary Statistics

Variable	Observations	Mean	Std. Dev.	Min	Max
Sale Growth	2,472	9.157	22.417	-90.619	98.888
Asset Growth	2,472	-39.896	53.658	-99.975	98.662
Labor Growth	2,472	13.507	24.439	-85.714	91.111
Total Deaths	2,472	3434	2783	50	5721
Affected Individuals	2,472	15.863	1.333	14.242	16.958
Firm Size (Small)	2,472	0.440	0.496	0.000	1.000
Firm Size (Medium)	2,472	0.214	0.410	0.000	1.000
Firm Size (Large)	2,472	0.346	0.476	0.000	1.000
Firm Legal Status (Sole Proprietorship)	2,472	0.495	0.500	0.000	1.000
Firm Legal Status (Partnership)	2,472	0.154	0.361	0.000	1.000
Firm Legal Status (Company)	2,472	0.352	0.478	0.000	1.000



Firm Ownership Status (Domestic)	2,472	0.978	0.148	0.000	1.000
Firm Ownership Status (Foreign)	2,472	0.019	0.138	0.000	1.000
Firm Ownership Status (Government)	2,472	0.003	0.053	0.000	1.000
Firm Age	2,472	19.096	13.456	1.000	143.000
Managerial Experience	2,472	16.642	9.798	0.000	60.000

Source: Authors' calculation

Moreover, the descriptive statistics of total deaths and affected individuals also have a large difference in minimum and maximum values, and the standard deviation is lower than then mean values.

**Error! Reference source not found.** shows the correlations of the variables used in the analyses. We used the Pearson correlation coefficient technique to testify the collinearity among variables. Based on the results, we can confidently state that collinearity among variables is within the tolerable range. Further the table depicts that sales growth has a negative correlation with both measures of disaster i.e. total death and affected individuals it means that disaster affects short run manufacturing firm's growth negatively. We can also define that both sales and labor growth are positively associated with both measures of disaster, as depicted by table 3.

Table 3: Correlation Matrix

	1	2	3	4	5	6	7	8	9	10	11	12	13	14	15
2	-0.018														
3	0.180 <sup>a</sup>	-0.037 <sup>c</sup>													
4	-0.153 <sup>a</sup>	0.055 <sup>a</sup>	0.139 <sup>a</sup>												
5	-0.153 <sup>a</sup>	0.055 <sup>a</sup>	0.139 <sup>a</sup>	0.868 <sup>a</sup>											
6	-0.122 <sup>a</sup>	-0.023	0.255 <sup>a</sup>	0.162 <sup>a</sup>	0.162 <sup>a</sup>										
7	0.060 <sup>a</sup>	0.048 <sup>a</sup>	-0.093 <sup>a</sup>	-0.325 <sup>a</sup>	-0.325 <sup>a</sup>	-0.462 <sup>a</sup>									
8	0.076 <sup>a</sup>	-0.018	-0.186 <sup>a</sup>	0.111 <sup>a</sup>	0.111 <sup>a</sup>	-0.645 <sup>a</sup>	-0.380 <sup>a</sup>								
9	-0.064 <sup>a</sup>	-0.006	0.148 <sup>a</sup>	-0.141 <sup>a</sup>	-0.141 <sup>a</sup>	0.454 <sup>a</sup>	0.018	-0.489 <sup>a</sup>							
10	0.036 <sup>c</sup>	-0.043 <sup>b</sup>	0.025	-0.217 <sup>a</sup>	-0.217 <sup>a</sup>	-0.050 <sup>a</sup>	0.089 <sup>a</sup>	-0.025	-0.422 <sup>a</sup>						
11	0.040 <sup>b</sup>	0.039 <sup>b</sup>	-0.175 <sup>a</sup>	0.312 <sup>a</sup>	0.312 <sup>a</sup>	-0.437 <sup>a</sup>	-0.087 <sup>a</sup>	0.531 <sup>a</sup>	-0.729 <sup>a</sup>	-0.314 <sup>a</sup>					
12	-0.036 <sup>c</sup>	-0.031	0.026	-0.001	-0.001	0.101 <sup>a</sup>	0.012	-0.115 <sup>a</sup>	0.116 <sup>a</sup>	-0.035 <sup>c</sup>	-0.096 <sup>a</sup>				
13	0.044 <sup>b</sup>	0.031	-0.031	-0.010	-0.010	-0.107 <sup>a</sup>	-0.016	0.126 <sup>a</sup>	-0.104 <sup>a</sup>	0.021	0.093 <sup>a</sup>	-0.933 <sup>a</sup>			
14	-0.016	0.003	0.008	0.028	0.028	-0.001	0.009	-0.007	-0.053 <sup>a</sup>	0.041 <sup>b</sup>	0.025	-0.353 <sup>a</sup>	-0.008		
15	-0.023	0.045 <sup>b</sup>	-0.098 <sup>a</sup>	-0.118 <sup>a</sup>	-0.118 <sup>a</sup>	-0.065 <sup>a</sup>	0.074 <sup>a</sup>	0.004	-0.050 <sup>b</sup>	0.036 <sup>c</sup>	0.025	-0.022	-0.009	0.083 <sup>a</sup>	
16	0.043 <sup>b</sup>	-0.004	-0.134 <sup>a</sup>	-0.282 <sup>a</sup>	-0.282 <sup>a</sup>	-0.121 <sup>a</sup>	0.118 <sup>a</sup>	0.024	-0.038 <sup>b</sup>	0.043 <sup>b</sup>	0.007	0.009	-0.002	-0.020	0.390 <sup>a</sup>

Source: authors' calculation

1=Sale Growth, 2=Asset Growth, 3=Labor Growth, 4=Total Deaths, 5=Affected Individuals, 6=Firm Size (Small), 7=Firm Size (Medium), 8=Firm-Size (Large), 9=Firm Legal Status (Sole Proprietorship), 10=Firm Legal Status (Partnership), 11=Firm Legal Status (Company), 12=Firm Ownership Status (Domestic), 13=Firm Ownership Status (Foreign), 14=Firm Ownership Status (Government), 15=Firm Age, 16=Managerial Experience

Table 3: The impact of natural disaster (total death) on firm growth

Variables	Sales Growth	Assets Growth	Labor Growth
Total Deaths	-6.540*** (-0.001)	2.520*** (0.001)	4.73*** (0.001)
Firm Size (Medium)	1.660* (2.147)	2.260** (7.008)	4.62*** (6.302)
Firm Size (Large)	1.950** (2.710)	0.490 (1.644)	5.79*** (8.465)
Firm Legal Status (Partnership)	0.800 (1.080)	-1.770* (-5.716)	1.07 (1.511)
Firm Legal Status (Company)	2.000** (2.591)	0.400 (1.250)	-4.38*** (-5.968)
Firm Ownership (Domestic)	0.550 (4.652)	0.240 (4.927)	0.47 (4.143)
Firm Ownership (Foreign)	1.050 (9.459)	0.910 (19.670)	-0.46 (-4.369)
Firm Age	-2.060** (-0.077)	1.350 (0.121)	-2.39*** (-0.0935)
Managerial Experience	0.460 (0.023)	-0.540 (-0.066)	-2.65*** (-0.1431)
Constant	1.000 (8.640)	-2.130** (-43.984)	2.54*** (23.028)
Number of observations	2,472	2,472	2,472
F-Value	5.21	5.57	14.55
Prob.> F	0.0000	0.0000	0.0000
R-squared	0.0428	0.0456	0.1109
Adj. R-squared	0.0346	0.0374	0.1033

Note: \*, \*\*, \*\*\* indicate significance at the 10%, 5%, and 1% levels, respectively.

Source: Authors' calculation

Table 3 provides the regression results. To test the significance in predicting the impact of natural disasters on firm growth, we used total deaths as a proxy to estimate natural disasters and OLS as an empirical method to testify the aforementioned objective. Moreover, we use three diverse proxies to quantify firm growth, i.e., sales growth, asset growth, and labor growth. The empirical findings suggest that there is a negative and significant relationship between natural disaster and sales growth (**Error! Reference source not found.**, column 1). These findings are in line with the previous study of (Lazzaroni & van Bergeijk, 2014) which stated that natural disasters enhance the direct cost of production and reduce the overall income level of inhabitants. These factors raise the price of products which can significantly harm the sales growth.

Furthermore, results also suggest a positive and significant relationship among natural disaster and asset growth (Table 3, column 2). These results show that at the time of disaster firms sell their assets to manage their cash flows.

By such a selling trend in asset markets significantly reduce the overall asset prices. In this situation, firms having sufficient cash buy the asset at a lower price, therefore, empirical evidence predicts a positive relationship between natural disaster and asset growth (Leiter et al., 2009). Lastly, based on empirical outcomes, we found a positive and significant linkage between natural disasters and labor growth (**Error! Reference source not found.**, column 3). These results are parallel to the study of (Skidmore & Toya, 2002) which demonstrates that labor growth can be increased after a natural disaster. Labor increases as a result of disaster as an alternate due to the absence of physical capital, which leads to growth and hereafter raises physical capital investment.

These results are further robust checks by changing the proxy of key independent variables i.e., from total deaths to the total number of affected individuals. The empirical results are shown in Table 4 support our previous findings i.e., natural disaster significantly impacts on firm growth. Particularly, the total number of the affected individual as a proxy of natural disaster negatively impacts on sales growth (Table 3, column 1); and positively impacts assets growth (Table 3, column 2) and labor growth (Table 3, column 3). Therefore, despite of changing the proxy for disaster the authors are able to get similar results.

Table 4: The impact of natural disaster (affected individual) on firm growth (Robust Check)

Variables	Sales Growth	Assets Growth	Labor Growth
Affected Individuals	-6.540*** (-2.810)	2.520*** (2.587)	4.73*** (2.135)
Firm Size (Medium)	1.660* (2.147)	2.260** (7.008)	4.62*** (6.302)
Firm Size (Large)	1.950** (2.710)	0.490 (1.644)	5.79*** (8.465)
Firm Legal Status (Partnership)	0.800 (1.080)	-1.770* (-5.716)	1.07 (1.511)
Firm Legal Status (Company)	2.000** (2.591)	0.400 (1.250)	-4.38*** (-5.968)
Firm Ownership (Domestic)	-1.480 (-4.807)	-1.890** (-14.743)	0.47 (4.143)
Firm Ownership (Foreign)	-1.050 (-9.459)	-0.910 (-19.670)	-0.46 (-4.369)
Firm Age	-2.060** (-0.077)	1.350 (0.121)	-2.39*** (-.0935)
Managerial Experience	0.460 (0.023)	-0.540 (-0.066)	-2.65*** (-.1431)
Constant	7.300*** (58.046)	-3.220*** (-61.098)	-0.62 (-7.335)
Number of observations	2,472	2,472	2,472
F-Value	5.21	5.57	14.55
Prob.> F	0.0000	0.0000	0.0000
R-squared	0.0428	0.0456	0.1109
Adj. R-squared	0.0346	0.0374	0.1033

Note: \*, \*\*, \*\*\* indicate significance at the 10%, 5%, and 1% levels, respectively.

Source: authors' calculation

## CONCLUSION AND POLICY IMPLICATIONS

Natural disasters are positively related to firms' physical assets and outputs, ultimately, firms have to face the impact on the firm's growth in the long run and short run. We investigate the disaster impact of multiple floods on firm growth using the firm-level panel data from Bangladesh, a developing country vulnerable to natural disasters and climate change, and identify the significance of the disastrous effect on the manufacturing firm performance.

To test the significance of natural disasters on firm growth, we used total death as a proxy to estimate natural disasters by using OLS empirical method. We find out the positive significance result in labor growth and assets growth to total death. In the short run of the study, total sales show the negative results to total death and affected individuals. Moreover, among the control variables, as firm age, firm size has a strong significance in the relation to total sales growth, but negative to assets growth and labor. Therefore, we may conclude that natural disaster has a positive impact on firm growth which affirms hypothesis of the study.

According to our study, the government should concentrate more on the effect of natural disasters on firm growth, and implement concise guidelines for firms to fulfill their disaster protection initiatives. First, the government should recommend a new policy for young firms; continue to strengthen their disaster management to mitigate risk at a minimum level. Second, the government should organize workshops and conferences for startups about disaster management and preparation.

The study suffers with few limitations. Our findings may be biased due to data limitations like that of the flood and cyclone disaster data and also the actual number of the manufacturing firms in the affected areas is unknown. As a result, we calculate an assumed number of firms in this study. We may extend our study across the borders for the future research. Also the study may be investigated by investigating the effects of different types of disasters individually.

## REFERENCES

- Anbarci, N., Escaleras, M., & Register, C. A. (2005). Earthquake fatalities: the interaction of nature and political economy. *Journal of Public Economics*, 89(9–10), 1907–1933.
- Baez, J., la Fuente, A., & Santos, I. V. (2010). Do natural disasters affect human capital? An assessment based on existing empirical evidence.
- Belasen, A. R., & Polachek, S. W. (2009). How disasters affect local labor markets: The effects of hurricanes in Florida. *Journal of Human Resources*, 44(1), 251–276.
- , J., Madsen, E. S., & Smith, V. (2012). Do firms' growth rates depend on firm size? *Small Business Economics*, 39(4), 937–947.
- Carvalho, V. M., Nirei, M., Saito, Y., & Tahbaz-Salehi, A. (2016). Supply chain disruptions: Evidence from the great east japan earthquake. *Columbia Business School Research Paper*, (17–5).
- Cavallo, E., & Noy, I. (2009). The economics of natural disasters: a survey (IDB Working Paper Series No. IDB-WP-124). *Inter-American Development Bank*. DC.
- Cavallo, Eduardo, Galiani, S., Noy, I., & Pantano, J. (2013). Catastrophic natural disasters and economic growth. *Review of Economics and Statistics*, 95(5), 1549–1561.
- Coad, A. (2007). Firm Growth: A Survey Papers on Economics and Evolution 2007-03. *Max Planck Institute of Economics, Evolutionary Economics Group*.
- Cole, M. A., Elliott, R. J. R., Okubo, T., & Strobl, E. (2013). Natural disasters and plant survival: The impact of the Kobe earthquake. *Discussion Papers*, 13063.
- Cole, M. A., Elliott, R. J. R., Okubo, T., & Strobl, E. (2017). Pre-disaster planning and post-disaster aid: Examining the impact of the great East Japan Earthquake. *International Journal of Disaster Risk Reduction*, 21(August 2016), 291–302. <https://doi.org/10.1016/j.ijdrr.2016.12.015>
- Cuaresma, J. C. (2010). Natural disasters and human capital accumulation. *The World Bank Economic Review*, 24(2), 280–302.
- De Mel, S., McKenzie, D., & Woodruff, C. (2012). Enterprise recovery following natural disasters. *The Economic Journal*, 122(559), 64–91.
- Felbermayr, G., & Gröschl, J. (2014). Naturally negative: The growth effects of natural disasters. *Journal of Development Economics*, 111, 92–106.
- FIALA., O., Fiala, O., & Fess. (2017). Natural disasters and Individual behaviour in developing countries. *Springer*.
- Fomby, T., Ikeda, Y., & Loayza, N. (2009). The growth aftermath of natural disasters. *The World Bank*.
- Hallegatte, S., & Przulski, V. (2010). The economics of natural disasters: concepts and methods. *The World Bank*.
- Hee, Y. T., Kalimuthu, K. V., Yu, L. C., Pong, C. S., & Chew, F. C. (2018). Do Natural Disasters Affect Economic Growth in Bangladesh? *International Journal of Business & Society*, 19(3).
- Kahn, M. E. (2005). The death toll from natural disasters: the role of income, geography, and institutions. *Review of Economics and Statistics*, 87(2), 271–284.
- Klomp, J., & Valckx, K. (2014). Natural disasters and economic growth: A meta-analysis. *Global Environmental Change*, 26, 183–195.
- Lazzaroni, S., & van Bergeijk, P. A. G. (2014). Natural disasters' impact, factors of resilience and development: A meta-analysis of the macroeconomic literature. *Ecological Economics*, 107, 333–346.
- Leiter, A. M., Oberhofer, H., & Raschky, P. A. (2009). Creative disasters? Flooding effects on capital, labour and productivity within European firms. *Environmental and Resource Economics*, 43(3), 333–350. <https://doi.org/10.1007/s10640-009-9273-9>
- Loayza, N. V., Olaberria, E., Rigolini, J., & Christiaensen, L. (2012). Natural disasters and growth: Going beyond the averages. *World Development*, 40(7), 1317–1336.
- McDermott, T. K. J. (2012). The effects of natural disasters on human capital accumulation. Available at SSRN 2011768.
- Noy, I. (2009). The macroeconomic consequences of disasters. *Journal of Development Economics*, 88(2), 221–231.
- Noy, I., & duPont IV, W. (2016). The long-term consequences of natural disasters—A summary of the literature.
- Noy, I., & Vu, T. B. (2010). The economics of natural disasters in a developing country: The case of Vietnam. *Journal of Asian Economics*, 21(4), 345–354.
- Raschky, P. A. (2008). Institutions and the losses from natural disasters. *Natural Hazards and Earth System Sciences*, 8(4), 627–634.
- Rodriguez-Oreggia, E., De La Fuente, A., De La Torre, R., & Moreno, H. A. (2013). Natural disasters, human development and poverty at the municipal level in Mexico. *The Journal of Development Studies*, 49(3), 442–455.
- Runyan, R. C. (2006). Small business in the face of crisis: identifying barriers to recovery from a natural disaster 1. *Journal of Contingencies and Crisis Management*, 14(1), 12–26.
- Skidmore, M., & Toya, H. (2002). Do natural disasters promote long-run growth? *Economic Inquiry*, 40(4), 664–687.
- Strobl, E. (2011). The economic growth impact of hurricanes: Evidence from US coastal counties. *Review of Economics and Statistics*, 93(2), 575–589.
- Strobl, E. (2012). The economic growth impact of natural disasters in developing countries: Evidence from hurricane strikes in the Central American and Caribbean regions. *Journal of Development Economics*, 97(1), 130–141.
- Tanaka, A. (2015). The impacts of natural disasters on plants' growth: Evidence from the Great Hanshin-Awaji (Kobe)

- earthquake. *Regional Science and Urban Economics*, 50, 31–41.
- Toya, H., & Skidmore, M. (2007). Economic development and the impacts of natural disasters. *Economics Letters*, 94(1), 20–25.
- Webb, G. R., Tierney, K. J., & Dahlhamer, J. M. (2002). Predicting long-term business recovery from disaster: a comparison of the Loma Prieta earthquake and Hurricane Andrew. *Global Environmental Change Part B: Environmental Hazards*, 4(2), 45–58.

## Semantics as Persuasive Cues in Donation-Based Crowdfunding Campaigns: The Moderating Role of Donation Category

Ting-Yu Hsu<sup>1</sup>  
Yin-Chi Tsai<sup>2</sup>  
Yu-chen Hung<sup>3,\*</sup>  
Wenting Liu<sup>4</sup>  
Jing Ren<sup>5</sup>  
Ding Ding<sup>6</sup>  
Jorng-Tzong Horng<sup>7</sup>

\*Corresponding author

<sup>1</sup> Department of Computer Science and Information Engineering, National Central University, Taoyuan, Taiwan, rye10140210@g.ncu.edu.tw

<sup>2</sup> Department of Computer Science and Information Engineering, National Central University, Taoyuan, Taiwan, gigi20020404@gmail.com

<sup>3</sup> Singapore University of Social Sciences, Singapore, ychung@suss.edu.sg

<sup>4</sup> Singapore University of Social Sciences, Singapore, wentingliu@suss.edu.sg

<sup>5</sup> Singapore University of Social Sciences, Singapore, jingren@suss.edu.sg

<sup>6</sup> Singapore University of Social Sciences, Singapore, dingding@suss.edu.sg

<sup>7</sup> Department of Computer Science and Information Engineering, National Central University, Taoyuan, Taiwan, horng@db.csie.ncu.edu.tw

### ABSTRACT

This study investigates the role of semantics as persuasive cues in donation-based crowdfunding campaigns across donation categories. Semantics have been shown to affect donation as part of narration technique. Drawing from the research on framing effect and schematic association of category, the study proposes that the persuasiveness of semantic cues depends on its consistency with categorical expectation. The consistency (vs. inconsistency) between semantic cues confirming to categorical expectation is to strengthen (vs. weaken) willingness to donate. The text analysis by LIWC showed that other-focused description increases willingness to donate, while self-focused description decreases willingness to donate. These findings suggest a sympathetic response towards descriptions on the occurrence of grave events happening to individuals; their needs for funds to travel for medical treatment are perceived highly worthy. The sympathetic feelings were ill afforded when the psychological process triggered by semantics are in conflict with categorical expectations. When words triggering cognition processes were present in the highly emotional category (such as funeral), they weakened donation. The results provide guidance for campaigners and crowdfunding platforms in communication strategies on appeal content within specific donation categories.

*Keywords:* donation-based crowdfunding, LIWC, content analysis, trust, empathy.

### INTRODUCTION

The rise of crowdfunding sites has empowered individuals to fundraise for people and causes they care about. With an effort to communicate about a worthy cause on the donation-based crowdfunding site (DCF) website, individuals can voice for worthy causes important to them personally. Unlike charitable organizations, individual fundraisers often do not have an official website, a well-established reputation, or a history of charitable activities to persuade donors. Due to the lack of credibility, campaign-specific information is critical to persuade donors for individual fundraisers (Berliner & Kenworthy, 2017; Kim et al., 2016; Kim et al., 2016). Thus, the study investigates content features in effective copy writing to appeal to individual donors by individual fundraisers on DCF.

The study on content features has largely been conducted on nonprofits as promoters for DCF campaigns (Salido-Andres et al., 2021). Campaign contents are shown to mitigate the trust issues as campaign details reduce information asymmetry between the organizer and the donor. However, Salido-Andres et al., (2022) show that detailed disclosure does not always be an effective predictor of donation. These mixed findings suggest that only the campaign detail that affords persuasive cues can effectively motivate potential donors to act. Hence, the study examined semantics as persuasive cues to donation campaign. Semantics have been shown to affect donation as part of storytelling technique (Rodiady et al. 2021). Drawing from the research on framing effect (Body & Breeze, 2016; Chung & Moriuchi, 2016) and schematic association of category (Hung and Guan, 2020), the study proposes that the persuasiveness of semantic cues depends on its consistency with categorical expectation. The consistency



(vs. inconsistency) between semantic cues confirming to categorical expectation is to strengthen (vs. weaken) willingness to donate. Taken together, the study answers the following questions:

- RQ1: What semantics constitute persuasive cues on donation-based crowdfunding?
- RQ2: How the persuasiveness of the semantic cues varies according to donation category?

Our studies analyzed over 7,000 cases on a well-established crowdfunding website, GoFundMe. The first study examined the role of semantics on donation by the text analysis software, Linguistic Inquiry and Word Count (LIWC) (Pennebaker et al., 2001). The results identified that positive cues and negative cues across all donation categories. First-person singular pronoun (“I”) is found to reduce donation in both donated amounts, whereas third person plural pronoun (“they”) increased enhanced donation amount. Our finding revealed that self-focused campaign is likely to decrease trust, while other-focused campaign is likely to enhance trust. These findings were in contradictory with the findings that the use of I as a “direct story telling technique” (“John said, ‘I’m happy’”) is more effect than the use of third person perspective as an indirect story telling technique” (“John said that he is happy”) by Rodiady et al (2021) in the childhood disease category. Our findings suggest that Rodiady et al (2021) finding applies to the children disease category, where the campaign is to benefit vulnerable children. The categorical expectation is other-focused, thus alleviating the barrier to trust. Under this context, the use of the right storytelling technique has a positive effect. Their finding supports that categorical expectation is critical. The second study continued to examine the varying effects of the semantics by donation category.

The identification of the two content features, semantics and donation category, in donation appeal offers theoretical advancement and managerial relevance. Firstly, text choice in movie synopsis has shown to bear significantly financial outcomes, such as to movie box office performance (Hung and Guan, 2020). However, donation is distinctive from transactional behavior, since psychological benefits are the major outcomes of the prosocial behavior. Benefiting other people, rather than benefiting self, is the major driver. With the distinctive antecedents and consequences, it is important to understand the role of semantics in persuasion. Our study also contributes to the growing research using text analysis on moral appeals (Hansen et al., 2018; Zhang et al., 2021). Moreover, our results confirm that campaign category moderates the persuasiveness of semantic cues on donation. Campaign category has not been studied as a strategic option, despite that few studies have stressed the importance of cause framing (Body & Breeze, 2016; Chung & Moriuchi, 2016). This is surprising as most DCF sites show donation categories on the landing page to help donors identify causes resonating with them. Donation category is also the first step that a promoter needs to identify when listing their campaign, before uploading their supporting materials. Our results support that donation category shall be considered a strategic choice when more than one category is applicable to a case. Furthermore, our studies suggest that trust is a critical underlying the matching between semantics and donation category.

In practice, our study highlights how crowdsourcing websites can harvest its data to help their campaign promoter. Most DCF sites offer tips to its users, such as providing photos, updating progress, and writing a good story. DCF sites can suggest to replace detrimental words to beneficiary words that fit into a chosen category in view of attracting donation. Digital platforms may also provide plug-ins such as generative AI to users. They can suggest to words as prompts to generate more appealing content. The better data-based insights and services can help the platforms to raise their popularity. The services based on content analysis can be used to a platform strategy strengthen both direct and indirect network effects to win competitions among DCF sites.

## LITERATURE REVIEW

### Donation-based Crowdfunding

Crowdfunding refers to an open call to the public to provide funding via the internet where donations are made or an exchange of funds or notional rewards is carried out (Belleflamme et al., 2014). Crowdfunding campaigns solicit contributions towards various such as technology, science, creative arts, business, and culture, artistic or social goals. Distinctive from other forms of crowdfunding where donors may receive material rewards, donation-based crowdfunding (DCF) campaigns involve a request for contributions without receiving material rewards. DCF has garnered interests from practitioners and academics alike, as it is an alternative fundraising strategy for a wide range of initiatives suitable for nonprofits and individuals pursuing socially beneficial causes.

The various parties involved in DCF campaigns include those who promote them (i.e., the promoter), those who donate to them (i.e., the donor), and those who may ultimately benefit from them (i.e., the beneficiary). Promoters can be traditional charitable organizations, or individuals who are in need, or who care about a person or an issue. Due to their expertise, charity organizations are more successful at soliciting donations than individuals. They view DCF as one of their routes for reaching a larger group of potential donors. Individuals, on the other hand, have few, if any, other ways to appeal to the public. In view of its significance to individual promoters, our research focuses on the campaign initiated by individual promoters on DCF.

### Enablers for Donation

In account for philanthropic giving, individual psychographics such as prosocial orientation and empathetic concern are important predisposition for donors (Neumayr and Handy 2017). Demographic factors also play a role. For example, older women are not only more likely to give (Carpenter, Connolly & Myer, 2009) but give larger accounts (Smith, 2012). Individuals

that are highly educated, practicing religion actively, in professional and managerial roles, middle aged, living in the least deprived parts of the county, well settled in a neighborhood are also more likely to donate.

However, individual characteristics are not sufficient to convert a donor prospect into a real donor. Trust is the primary enabler of sympathetic deeds. Owing to information asymmetry, a promoter needs to build trust by conveying perception of trustworthiness. Charitable organizations have shown to influence donors due to their trustworthiness if they can show reliability and credibility through past campaigns (Tremblay-Boire & Prakash, 2017). Their trustworthiness relies on honest behaviors, effective performance and transparency regarding financing uses. More information on promoters and their previous projects are requirements for success in DCF because of the aforementioned information asymmetry between a charity cause and contributors. As a result, the amount of information shared on the promoters greatly influences the level of donor support. In comparison to nonprofit organizations, individual promoters lack the credibility that comes from earlier works. Therefore, potential contributors will heavily rely on campaign content to determine its trustworthiness.

Research has documented other motivational factors to donation on crowdsourcing platforms, including psychological involvement, perceived impact and identification. Techniques facilitative of greater involvement, identification and impact are more persuasive. Specifically, vivid description increases psychological involvement (Berliner and Kenworthy 2017; Kim et al. 2016b). Affectionate storytelling style are effective persuasive techniques (Rodiady et al., 2021). Perceived impact and identification to the fund raising group also enhances donation intention (Wang et al., 2019). Taken together, semantics associated with vivid description, affective-rich storytelling, impactful outcome and identification are likely to enhance trustworthiness and become persuasive cues.

### *Semantics as Persuasive Cues*

The choice of words is a linguist strategy to include linguistic cues to convey meaning in order to persuade readers (Hung & Guan, 2020). Linguistic cues consist of syntactic cues and semantic cues. Syntactic information is the linguistic nature of a word within a sentence structure – such as a verb, an adjective, a preposition, a count noun, or a mass noun. Semantic cues offer the meaning of a word provided. The study focuses on semantic cues in donation appeal of DCF, as semantics convey meanings that may activate or deactivate sympathy toward the beneficiary. Ample evidence suggest that semantics act as persuasive cues to enhance motivation for donation, such as the use of appropriate language (Kim et al. 2016a), describing beneficiaries' merits in visual vividness (Berliner and Kenworthy 2017; Kim et al. 2016b), affectionate narration, and effective framing of causes (Body & Breeze, 2016; Chung & Moriuchi, 2016). These persuasive cues are likely to determine the campaign's perceived credibility and raise its chances of success (Berliner & Kenworthy, 2017; Kim et al., 2016a; Kim et al., 2016b). Therefore, campaigns encompassing persuasive cues are likely to be successful.

H1: Semantics serve as persuasive cues to impact on willingness to donate.

An altruistic motive is more likely to gain trust. This is because Donors are motivated by the warm glow from altruistic deeds (Gleasure & Feller 2016). Donors prefer beneficiaries whose needs arise from little fault of their own, or free from culpability (Fenton, Golding & Radley, 1993). When one person is soliciting donation for oneself, it may trigger attribution of failure to self, such as mismanagement of own finance, or ill consideration. On the contrary, soliciting donation for self is likely to trigger more deliberation, entailing suspicion for self-gain or greediness (Feng et al., 2022). From this perspective, we might expect that self-focused description decreases willingness to donate, whereas other focused description decreased willingness to donate. This, in turn, lead to the prediction that the presence of semantics suggestive of a self-focus, such as “I” will weaken the trust, whereas the presence of semantics associated with other-focus, such as third person singulars or plurals, will strengthen trust.

H1a: other-focused description increases willingness to donate

H1b: self-focused description decreases willingness to donate

However, recent findings suggest alternative perspective. Rodiady et al. (2021) found that the use of I as a “direct story telling technique” (“John said, ‘I’m happy’”) is more effect than the use of third person perspective as indirect story telling technique” (“John said that he is happy”) in the childhood disease category. One reason is that Rodiady et al (2021) finding pertains to the “children disease” category, in which the beneficiary is unambiguously vulnerable children. The categorical expectation is for the benefits of others. This other-focused category serves to alleviate the barrier to trust. The presence of “I” as a storytelling technique has a positive effect, due to a stronger affective feeling.

Their study suggests two things. Firstly, donation category is critical as it actives a certain set of expectations and associations. Secondly, donation category may serve to filter “whether to donate” prior to deciding on “how much to donate” (Xu and Wyer 2008). Most previous studies on semantics as persuasive cues attempt to answer how much to donate, or the magnitude of donation. For example, a higher involvement, identification, and perceive impact enhances donation intention. Corroboratively, descriptions generating affective feelings trigger valuation by feeling, whilst affect-poor content is likely triggers more cognitive deliberation, or valuation by calculation (Hsee & Rottenstreich, 2004). However, they neglect that the fit of semantics to categorical expectation may play a role on deciding to “whether to donate” in the first place. That is, donation category sets the background to determine the affordance of semantics as persuasive cues in accordance to categorical expectations and

associations. There, we discuss the role of donation category to moderate the relationship between semantics and donation in the next session.

### **Donation Category**

The affordance of semantics as persuasive cues shall depend on the donation category in which they appear. Donation category is likely to serve as a schema that activates different sets of social norms and associations. Two streams of literature offer corroborative evidence. Firstly, Hung & Guan (2020) establish that movie category (i.e., genre) is a schema that activates distinctive knowledge and expectation to guide movie choices. A synopsis comprising words consistent to categorical expectation enhances movie box office performance. Secondly, Clark (1997) offers the notion of the construction of sympathy, which describes that individuals give sympathy only under the conditions where social norms permeates as “deserving”. As a result, the framing of donation causes widely affect donor’s sympathy (Body & Breeze, 2016; Chung & Moriuchi, 2016). For example, a campaign cause on supporting an inmate’s children and families can focus on children, including an image of happy children, followed by short films highlighting how to donation helps to bond the child and their inmate parents. A framing on helping an innocent child helps to determine the case is “worthy” of one’s sympathy. Donation category is likely to activate schematic associations to circumscribe the nature of the needs. When the framing makes an appeal more relevant to self, it is likely to trigger involvement.

H2: The relationship between semantic cues and donation is affected by donation category.

## **METHODOLOGY**

### **STUDY 1**

#### **Data Collection**

The source of our research data is the GoFundMe website (<http://www.gofundme.com/>). A total of 7,750 cases in English were collected from the website. After filtering out charitable organizations as project initiators, the final dataset contained 7,069 cases. Each case came with project name, project category, descriptions, funding goal, project launch date, project organizers, the number of donors, the total amount raised as of the retrieval date, and the number of comments on the projects by donors. The total amount of donation was divided by the active days to form average daily donation (ADD). The dataset contained 15 donation categories that was self-indicated by the project promoter, including “Funerals & Memorials” (n=871), “Emergencies” (n=833), “Events” (n=487), “Travel”(n=486), “Rent, Food & Monthly Bills“ (n=481) , “Wishes”(n=477), “Animals”(n=442), “Faith”(n=402), “Medical”(n=389), “Sports“ (n=376), “Volunteer” (n=323), “Business”(n=314), “Environments” (n=300) and “Other (n=373)”.

#### **Data Analysis**

Average daily donation (ADD) was regressed on the campaign description analyzed by the well-established text analysis software, Linguistic Inquiry and Word Count (LIWC) (Pennebaker et al., 2001). Five pronoun categories under the linguistic dimensions and twelve main categories underpinning psychological processes were included. The five pronoun categories are first-person singular pronouns, first-person plural pronouns, second-person pronouns, third-person singular pronouns, and third-person plural pronouns. The twelve main categories include drives, cognition, affect, social processes, culture, lifestyle, physical, states, motives, perception, time orientation, and conversational. The categorical descriptive are provided in table 1. Three control variables were entered in the regression: number of donors, funding goal and word count. After analyzing ADD, the study also regressed number of donors on the LIWC outputs, controlling for fundraising goal, days since launch and word count.

The Variance Inflation Factor (VIF) test was conducted prior to the regression analysis to gauge the multicollinearity. The results of this multicollinearity test are provided in Appendix A. From the outcomes displayed in the appendix, it is evident that, with the exception of "Drive" and "Social," all other variables exhibit VIF values below 10. Furthermore, in accordance with findings from The Development and Psychometric Properties of LIWC-22, these two variables, "Drive" and "Social," are determined to be independent of each other, thereby ruling out the issue of multicollinearity.

Table 1: The descriptive table of variables based on LIWC

	mean	std	min	25%	50%	75%	max
i	3.57	3.79	0.00	0.00	2.42	5.77	22.22
we	2.00	2.52	0.00	0.00	1.15	3.01	25.00
you	1.41	1.47	0.00	0.00	1.13	2.13	16.67
shehe	2.33	2.97	0.00	0.00	0.72	4.35	19.23
they	0.79	1.53	0.00	0.00	0.00	1.00	11.63
Drives	8.23	4.19	0.00	5.38	7.58	10.34	50.00
Cognition	9.45	4.05	0.00	6.67	9.19	11.93	34.78
Affect	7.71	3.34	0.00	5.41	7.32	9.52	37.50
Social	17.17	6.27	0.00	12.96	16.90	20.98	66.67
Culture	0.43	0.96	0.00	0.00	0.00	0.53	11.54
Lifestyle	5.52	3.45	0.00	3.12	4.92	7.32	40.00
Physical	2.52	2.68	0.00	0.00	1.78	3.89	33.33
States 1_need	0.77	1.19	0.00	0.00	0.00	1.22	14.29
States 2_want	0.38	0.71	0.00	0.00	0.00	0.67	11.11
States 3_acquire	0.77	1.04	0.00	0.00	0.51	1.25	14.29
States 4_lack	0.20	0.73	0.00	0.00	0.00	0.00	13.04
States 5_fulfill	0.14	0.40	0.00	0.00	0.00	0.00	5.26
States 6_fatigue	0.01	0.10	0.00	0.00	0.00	0.00	3.45
Motives 1_reward	0.32	0.70	0.00	0.00	0.00	0.00	13.95
Motives 2_risk	0.29	0.64	0.00	0.00	0.00	0.27	12.50
Motives 3_curiosity	0.21	0.61	0.00	0.00	0.00	0.00	8.45
Motives 4_allure	6.95	3.09	0.00	4.85	6.72	8.77	42.86
Perception	7.58	3.36	0.00	5.36	7.37	9.60	30.43
TO 1_time	3.89	2.47	0.00	2.13	3.68	5.34	22.22
TO 2_focuspast	2.95	2.42	0.00	1.11	2.56	4.32	16.28
TO 3_focuspresent	5.40	2.57	0.00	3.66	5.22	6.93	28.57
TO 4_focusfuture	1.83	1.69	0.00	0.61	1.55	2.68	33.33
Conversation	0.21	0.62	0.00	0.00	0.00	0.00	11.11
Goal	14478.67	106292.97	1.00	1500.00	4000.00	10000.00	600000.00
Days since launch	65.52	42.10	6.00	39.00	59.00	85.00	392.00
WC	117.62	64.55	3.00	76.00	111.00	148.00	946.00
Current donors	81.17	351.80	1.00	13.00	27.00	64.00	16500.00
Support number	4.21	17.70	0.00	0.00	1.00	3.00	740.00
Daily donation	138.81	511.26	0.04	9.67	28.89	107.14	18180.57

## RESULTS

The regression analysis on ADD showed semantics affected average daily donation, in support of H1. Specifically, four sets of semantics significantly increased ADD, including third-person plural pronouns ( $\beta_{they} = 19.21, p < .001$ ), "risk" ( $\beta_{risk} = 17.57, p = .002$ ), past-oriented words ( $\beta_{focus\ past} = 6.90, p = .003$ ), future-oriented words ( $\beta_{focus\ future} = 5.96, p = .04$ ). On the contrary, three sets of semantics significantly decreased ADD, including first-person pronoun ( $\beta_I = -7.27, p < .001$ ), "cognition" ( $\beta_{cog} = -4.58, p < .001$ ), "acquire" ( $\beta_{acq} = -14.41, p < .01$ ). Among the three control variables, more donors led to higher ADD ( $\beta_{donors} = 0.80, p < .001$ ) and more words also increased donation amount ( $\beta_{WC} = 0.90, p < .001$ ). The funding goal did not have a significant effect on the funding outcome ( $\beta_{goal} < 0.001, p = .82$ ). The results suggest that use of third-person plural pronouns ("they") increased the perception that the promoter is altruistic and making an effort to benefiting others, rather than self ("I"). The altruistic motive, with an emphasis on the risk that a beneficiary is exposed to, conveyed in a clear time line (from past to future) is most convincing. Conversely, a self-focused campaign to gain resources with semantics that trigger thinking was proven ineffective in soliciting sympatric response.

Furthermore, we examined the number of donors. Four sets of semantics significantly increased number of donors, including second-person plural pronouns ( $\beta_{we} = 5.16, p = .04$ ), "affect" ( $\beta_{affect} = 3.91, p < .01$ ), past-oriented words ( $\beta_{focus\ past} = 4.31, p = .03$ ), future-oriented words ( $\beta_{focus\ future} = 5.71, p = .02$ ). On the contrary, three sets of semantics significantly donor number, including first-person pronoun ( $\beta_I = -3.39, p = .001$ ), "cognition" ( $\beta_{cog} = -3.91, p = .001$ ), "drives" ( $\beta_{drive} = -3.91, p = .01$ ). Among the three control variables, more words also increased donor number ( $\beta_{WC} = 0.12, p = .04$ ). Taken together, past and future words not only increased donation amount, but also donor number. On the contrary, the self-centered cause with words that triggered more cognitive response decreased donors and their donation amount.

## STUDY 2

To further investigate the divergent results of text characteristics on donation across donation categories, we identified the keywords in different categories. We then discuss the divergent effects in relations to the enabler of sympathy as suggested in the literature.

### Data Analysis

Study 2 conducted regression analysis on average daily donation and donor number within each of the donation category. H2 posits that the persuasiveness of linguistics cues varies according to category. We expect that the semantics strengthen donation intention when they are indicative of the worthiness of beneficiary in accordance with categorical expectation, whereas the semantics weaken the feeling of sympathy when they are associated with personal gain.

### Results

Words associated “risk” perception such as danger, concerns and things to avoid significantly increased ADD under funerals and memorial ( $\beta_{risk\_MF} = 15.80, p = .03$ ) and travel ( $\beta_{risk\_travel} = 3.84, p = .04$ ). Past orientation, including past-tense verbs and references to past events/times also increased ADD ( $\beta_{past\_medical} = 14.70, p = .02$ ). These findings suggest a sympathetic response towards descriptions on the occurrence of grave events happened to individuals; their need for funds to travel for medical treatment are perceived highly worthy. Corroboratively, vivid description using “physical” expressions for such travel ( $\beta_{physical\_avel} = 0.83, p = .001$ ) also strengthened the response. Hence, the sympathetic feelings are sufficiently afforded by the presence of persuasive cues in the rightful donation category. Furthermore, donors can be motivated by a positive feeling of making an impact such as alleviating worthy beneficiaries from a miserable situation to a better future. Thus, a future orientation increased donation for funeral ( $\beta_{future\_funeral} = 8.64, p = .01$ ), animal rescue ( $\beta_{future\_animal} = 34.1, p = .04$ ), medical causes ( $\beta_{future\_medical} = 25.00, p < .01$ ) and volunteering acts ( $\beta_{future\_volunteer} = 5.76, p = .02$ ).

In contrast, words suggestive of self-focus, “I”, lowered ADD under the events ( $\beta_{I\_event} = -0.93, p = .03$ ), rent, food & monthly bill ( $\beta_{I\_bill} = -9.94, p = .02$ ), faith ( $\beta_{I\_faith} = -1.64.94, p < .01$ ), family ( $\beta_{I\_family} = -16.20, p = .02$ ), and medical ( $\beta_{I\_bill} = -16.00, p < .001$ ). Since these categories do not suggest urgency, asking for fund is perceived to be for personal gain. The lack of urgency in these categories weaken sympathetic feelings as individuals are perceived to be culpable of mismanaging own finance. Similar responses are seen in words associated with “acquire”, such as get and take, for the family and medical causes ( $\beta_{acquire\_family} = -38.7, p = .03$ ;  $\beta_{acquire\_medical} = -41.20, p < .001$ ). The sympathetic feelings are ill afforded; cognitive responses occurred to critically evaluate the worthiness of such appeals. The same cognitive responses occur when words triggering cognition processes, such as causation (because, why), differentiations (but, if, or) were present in the highly emotional category, such as funeral ( $\beta_{cog\_funeral} = -5.16, p < .001$ ). The sympathetic feelings were ill afforded when the psychological process triggered by semantics are in conflict with categorical expectations.

## DISCUSSION AND CONCLUSION

The research conducted analysis of the description of crowdfunding projects on the GoFundMe website, aiming to identify the relationship between semantic cues and donation with the well-established text analysis method of Linguistic Inquiry and Word Count (LIWC). The research found that the language used in the description of crowdfunding projects indeed has an impact on the amount of funds raised. Moreover, the effect language differs across fundraising projects under distinctive categories.

In two studies, our results provide concrete guideline for fundraisers to effectively select keywords in accordance with thematic categorization so as to maximize the persuasiveness.

This study is limited to only one crowdsourcing website. Moreover, the progression of donation over a period of time is unobserved in our dataset. Other unobservable variables include donor profiles (demographics and psychographics), and history on the crowdsourcing site. In addition, our analysis was only limited to the text without considering the inputs from image. Future studies shall examine the interaction effects between image and text as both are important content features.

## ACKNOWLEDGMENT

The respective contributions from the author team are the following. Dr. Hung has contributed to project idealization, theoretical conceptualization, and manuscript preparation. Ting-Yu Hsu & Yin-Chi Tsai collected the data, conducted the analysis and reported the analysis results. Dr. Ren & Dr. Liu have provided detailed guidance on methodology analysis. Prof Horng provides valuable feedback on conceptualization, methodology, and resourcing during all phases of the research.

## REFERENCES

- Berliner, L. S., & Kenworthy, N. J. (2017). Producing a worthy illness: Personal crowdfunding amidst financial crisis. *Social Science & Medicine*, 187, 233-242. <https://doi.org/https://doi.org/10.1016/j.socscimed.2017.02.008>
- Body, A., & Breeze, B. (2016). What are ‘unpopular causes’ and how can they achieve fundraising success? *International Journal of Nonprofit and Voluntary Sector Marketing*, 21(1), 57-70. <https://doi.org/https://doi.org/10.1002/nvsm.1547>
- Chung, C., & Moriuchi, E. (2016). The effectiveness of donation advertising: An experimental study for felt ethnicity and messages on in-groups and out-groups. In *Celebrating America’s Pastimes: Baseball, Hot Dogs, Apple Pie and Marketing? Proceedings of the 2015 Academy of Marketing Science (AMS) Annual Conference* (pp. 745-746). Springer



International Publishing..

- Diep-Nguyen, H., & Yang, J. (2021). Trust in Crowdfunding: Experimental Evidence from a Fundraising Campaign. Available at SSRN 3972418.
- Einolf, C. J. (2012). Is cognitive empathy more important than affective empathy? A response to “who helps natural-disaster victims?”. *Analyses of Social Issues and Public Policy*, 12(1), 268-271.
- Elo, S., & Kyngäs, H. (2008). The qualitative content analysis process. *Journal of advanced nursing*, 62(1), 107-115.
- Francis, M. E., & Pennebaker, J. W. (1992). Putting stress into words: The impact of writing on physiological, absentee, and self-reported emotional well-being measures. *American Journal of Health Promotion*, 6(4), 280-287.
- Gleasure, R., & Feller, J. (2016). Does heart or head rule donor behaviors in charitable crowdfunding markets?. *International Journal of Electronic Commerce*, 20(4), 499-524. <https://doi.org/10.1080/10864415.2016.1171975>
- Goering, E., Connor, U. M., Nagelhout, E., & Steinberg, R. (2011). Persuasion in fundraising letters: An interdisciplinary study. *Nonprofit and voluntary sector quarterly*, 40(2), 228-246.
- Pennebaker, J. W., Francis, M. E., & Booth, R. J. (2001). Linguistic inquiry and word count: LIWC 2001. *Mahway: Lawrence Erlbaum Associates*, 71(2001), 2001.
- Hansen, S. L., Eisner, M. I., Pfaller, L., & Schickltanz, S. (2018). “Are you in or are you out?!” Moral appeals to the public in organ donation poster campaigns: A multimodal and ethical analysis. *Health Communication*, 33(8), 1020-1034.
- Hung, Y.-C., & Guan, C. (2020). Winning box office with the right movie synopsis. *European Journal of Marketing*.
- Kim, J. G., Kong, H. K., Karahalios, K., Fu, W.-T., & Hong, H. (2016). The Power of Collective Endorsements: Credibility Factors in Medical Crowdfunding Campaigns, *Proceedings of the 2016 CHI Conference on Human Factors in Computing Systems*, San Jose, California, USA. <https://doi.org/10.1145/2858036.2858289>
- Kim, P. H., Buffart, M., & Croidieu, G. (2016). TMI: Signaling Credible Claims in Crowdfunding Campaign Narratives. *Group & Organization Management*, 41(6), 717-750. <https://doi.org/10.1177/1059601116651181>
- Ordanini, A., Miceli, L., Pizzetti, M., & Parasuraman, A. (2011). Crowd-funding: transforming customers into investors through innovative service platforms. *Journal of service management*.
- Salido-Andres, N., Rey-Garcia, M., Alvarez- Gonzalez, L. I., & Vazquez-Casielles, R. (2021). Mapping the field of donation-based crowdfunding for charitable causes: systematic review and conceptual framework. *VOLUNTAS: International Journal of Voluntary and Nonprofit Organizations*, 32, 288-302.
- Tremblay-Boire, J., & Prakash, A. (2017). Will you trust me?: How individual American donors respond to informational signals regarding local and global humanitarian charities. *VOLUNTAS: International Journal of Voluntary and Nonprofit Organizations*, 28, 621-647.
- Zhang, Z., Jin, J., Luo, C., & Chen, A. (2022). Excavating the social representations and perceived barriers of organ donation in China over the past decade: A hybrid text analysis approach. *Frontiers in Public Health*, 10, 998737.

## APPENDIX A: VIF Table of Variables

Variables	VIF	Variables	VIF
i	3.09	States 6_fatigue	1.02
we	3.89	Motives 1_reward	1.42
you	2.91	Motives 2_risk	1.27
shehe	3.99	Motives 3_curiosity	1.15
they	1.83	Motives 4_allure	7.12
Drives	12.86	Perception	5.77
Cognition	7.54	TO 1_time	3.77
Affect	8.96	TO 2_focuspast	3.34
Social	27.35	TO 3_focuspresent	6.2
Culture	1.24	TO 4_focusfuture	2.29
Lifestyle	3.73	Conversation	1.16
Physical	2.11	Goal	1.01
States 1_need	1.61	Days since launch	3.19
States 2_want	1.44	WC	3.87
States 3_acquire	1.67	Current donors	2.53
States 4_lack	1.16	Support number	2.54
States 5_fulfill	1.15		



## Social Media Advertising in The Recent Years: A Bibliometric Analysis and Thematic Overview

Sarita Nagvanshi<sup>1,\*</sup>  
Neha Gupta<sup>2</sup>  
Vinod Kumar<sup>3</sup>

\*Corresponding author

<sup>1</sup> Research Scholar, Amity University, Noida, India, sarita.singh247@gmail.com

<sup>2</sup> Assistant Professor, Amity University, Noida, India, ngupta10@gmail.com

<sup>3</sup> Professor, New Delhi Institute of Management, Delhi, India, vinodsaini6388@gmail.com

### ABSTRACT

Social media advertising has developed as a quick and efficient way to engage target customers and expand marketing campaigns in the fast-paced world of marketing. Despite the growing body of research in this area, there is a scarcity of review studies that synthesise important trends and probable future directions in social media advertising research. To fill this gap, we conducted a bibliometric study, using modern technologies to synthesise global knowledge structure and uncover emergent themes. The dataset included Scopus-indexed literature from 2018 to 2022, with the primary keywords "social media advertising," "social media advertisement," and "social media ad" being used. We conducted co-authorship, citation, bibliographic, and co-occurrence analysis using the VOSviewer tool to identify the top contributors and important research trends. Key findings show that certain themes received a lot of attention during the study period. Specifically, researchers investigated subjects such as purchase intention, sales, consumption behaviour, social influence, branding, perception, and attitudes, among others. An objective and quantitative summary of the major contributors and research trends has been provided in the paper.

*Keywords:* Social media, Social media advertising, Social networks, Online advertising, online marketing

### INTRODUCTION

Our world has undergone a significant transformation because of the Internet's extraordinary expansion and the profound societal disruptions it has wrought through inventions and breakthroughs (Beig & Khan, 2018). It has given today's innovative firms tremendous chances to work together and forge enduring relationships with their target clients. Since 2014, it has grown at a global annual growth rate of 14%, making it the fastest-growing form of communication. In recent times, interactive marketing has emerged as a crucial tactic used by businesses to strengthen their brands and draw in more clients (Hanaysha, 2016). Social media, according to Kaplan & Haenlein, (2010), is one of the internet-based initiatives that aims to assist users in sharing their thoughts, knowledge, and previous experiences through social networking sites, content areas, and blogs. The rise of social media has not only fundamentally affected how people communicate but has also reshaped the landscape of digital marketing (Huo et al., 2020). As a result of its proven cost-effectiveness and convenience, social media has emerged as a key platform for businesses to promote their brands (Keller, 1993), earning it a reputation as an authentic advertising technique.

According to Raji et al., (2019) and Taylor et al., (2011), social media advertising is any creative content produced on social media platforms to target consumers. As a result, advertisements posted on websites like Facebook, Twitter, Instagram, and YouTube fall under this definition (Khaleeli, 2020). Social media advertising is advantageous to marketers as well as the social networking site itself (Jung et al., 2016), as it is less expensive while still reaching a larger audience (Lai & Ren, 2016). In order to advertise their goods and services on online platforms, businesses use a variety of strategies, including banner ads, embedded videos, animations, brand sites, surveys, classified ads, and sponsored ads (Ahmed & Raziq, 2017). It chooses target audiences depending on their application and engagement with social networks (Jung et al., 2016);(Irfan et al., 2017). All of these brand-building actions either use Facebook to promote sales, Twitter to start a trend (using hashtags), upload a video of a new product to YouTube, interact with others through photos on Instagram, publish a blog on HubSpot, or connect with brand managers on LinkedIn (Ahmed & Raziq, 2017). Although a significant amount of research on social media as an advertising/promotional vehicle has just begun to appear, an increasing number of marketing and communication scholars have devoted their attention to the study of advertising in social media (Okazaki et al., 2012). Since social media advertising is still a relatively new field, there isn't a lot of published research that reviews and provides a background of the field, which results in an incomplete picture of SMA developments through time. Literature reviews can point out directions for future research in advertising studies. (Carlson, 2015) and (Faber, 2015). Most reviews so far have been restricted to broad social media studies, with little progress made in theory development in the field of advertising research (Chu et al., 2020). In contrast, this study

focuses specifically on social media literature from the last five years, which also happened to be the period that saw a sharp increase in publishing in the field. Approximately 79% of all the SMA studies were done in this period.

Some studies that have reviewed the SMA literature have made a huge impact, and this paper is only an extension of those works. A theoretical review by Huo et al., (2020) provides a complete picture of social media advertising reactance studies, introduces a thorough theoretical framework (the Social Media Advertising Reaction Model, or SMARM), and offers insights into both research and practice. Another review by (Huo et al., 2020) focuses on evaluating the body of knowledge already available on social media advertising's impact on the hospitality, tourism, and travel (HTT) industries. Knoll (2016) in their review of advertising in social media found seven emerging themes such as the use of advertising in social media, attitudes about and exposure to advertising, targeting user-generated content in advertising, electronic word-of-mouth in advertising, consumer-generated advertising, and further advertising effects.

Table 1: Comparison of the current study with earlier studies

Basis for comparison	Honghong Huo, Zhiyong Liu, and Qingfei Min (2020)	Shu-Chuan Chu, Tao Deng, and Hong Cheng, (2020)	Johannes Knoll (2015)	Our Study
Time period	(2010-2020)	(2004-2019)	( - 2014)	(2018-2022)
Keywords	Advertising reactance, social media advertising, psychological reactance theory.	Advertising, Social media, Hospitality, Travel, Tourism and travel, User-generated content	web 2.0; social media; social network sites; advertising; review; research agenda	
Focus of the study	Social media advertising reactance model	Social media advertising in hospitality, tourism, and travel.	Social media advertising across disciplines.	Social media advertising across disciplines.
Methodology	Theoretical review method	Theoretical review method	Theoretical review	Bibliographic coupling, thematic analysis, citation analysis, content analysis
Papers referred	92	192	51	223
Database	EBSCO, Elsevier, Web of Science and Google Scholar	Business Source Complete and Communication and Mass Media Complete	Business Source Premier, and Communication and Mass Media Complete	Scopus

This study's key focus is to give a comprehensive overview of the top countries, organizations, publications, and authors, as well as the most widely read papers and upcoming research agendas in the field of social media advertising. The current review adds to and advances earlier studies on social media advertising that take a particular approach, such as domain-based, theory-based, or methodology-based systematic reviews. The objectives and methodology used in this study are distinctive, and it tackles the following research questions:

1. What is the recent statistical breakdown of SMA publications and citations?
2. How do different scientific players contributing to the SMA literature such as journals, authors, countries, keywords, etc perform?
3. What are the dominant research themes in SMA, and how is the area evolving?
4. What prospective research avenues exist in the area?

## METHODOLOGY

This bibliometric study's scientific mapping procedure adheres to the conceptual framework put forth by (Zupic & Čater, 2015) and (Aria & Cuccurullo, 2017). The paper is structured as follows: first, the methodology part includes the process of data collection, loading, conversion, and extraction based on specific keyword searches. Following that, the analysis and findings section lists the top journals, authors, affiliations, and countries that have contributed to SMA research and the emerging

research trends. Finally, the limitations of this work, potential future research directions, and a conclusion have been highlighted.

In recent years, bibliometric analysis has grown in popularity in business research (Donthu et al., 2021). Bibliometric analysis, in conjunction with citation and co-citation analysis, is a useful tool for analyzing the patterns and features of previously published articles on any scientific subject (Faruk et al., 2021).

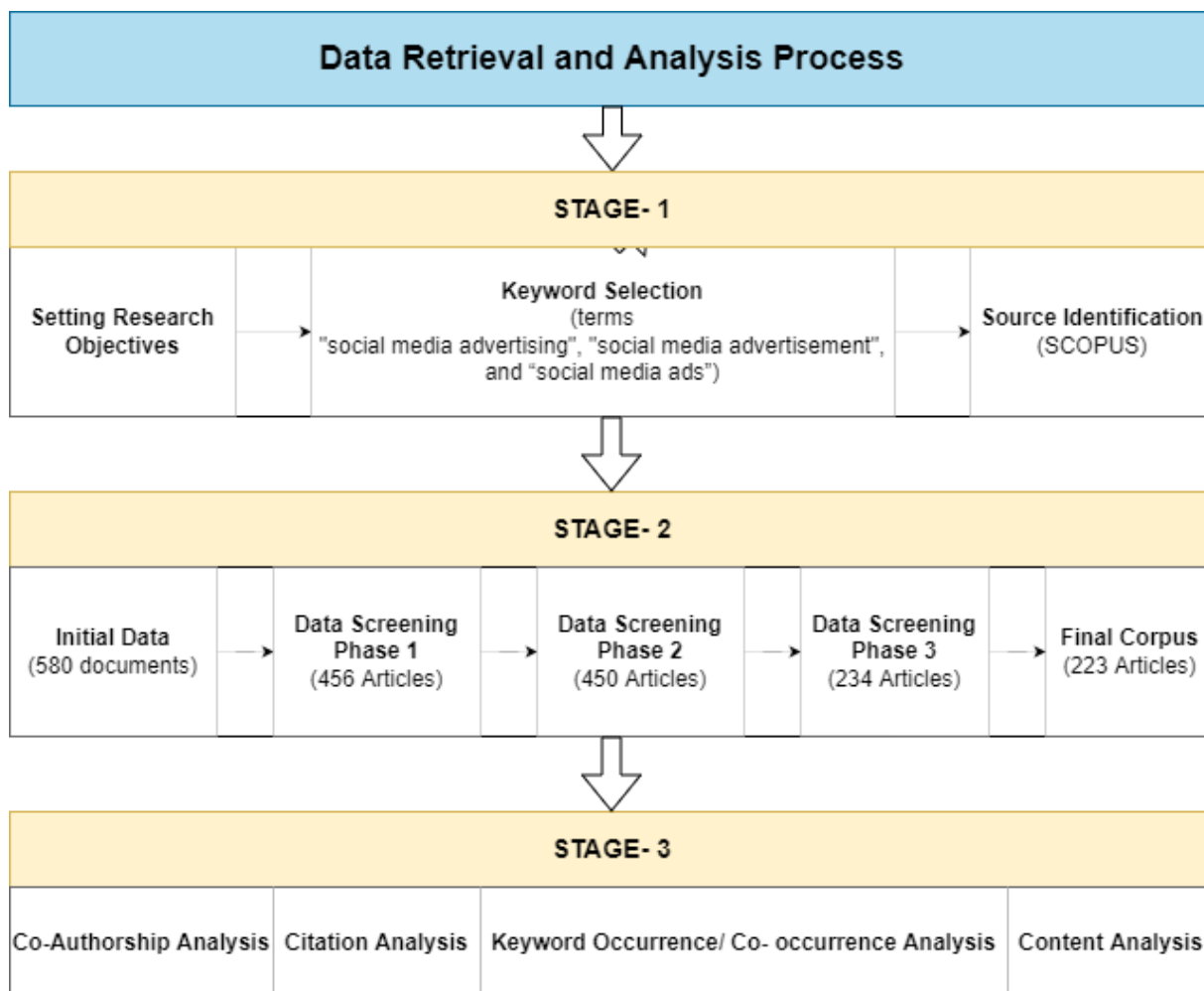

Figure 1: Flowchart of the data-retrieval and Analysis process.

To find relevant studies, a three-stage data retrieval, selection, and analysis approach was used (fig 1). First, the research objectives and questions were formulated, and a document search in the Scopus database was conducted using the terms ‘social media advertising’, ‘social media advertisement’, and ‘social media ads’. Scopus is a well-known and reliable bibliometric database that not only displays metadata records but also curates author profiles and abstracts from journals, conference proceedings, and book series throughout the world (Baas et al., 2020).

In the second stage, a preliminary search was executed with the given keywords. The database was retrieved on June 16, 2022, and it yielded 580 seminal articles from 2008 to 2022, which were further limited by the number of years, subject area, document type, and language. The search was restricted to English language studies over a period of five years, from 2018 to 2022. This search resulted in a list of 450 documents. The Scopus database search results were limited in two more phases using inclusion and exclusion criteria to obtain a selection of the most relevant articles linked to the research topic. First, the subject area was limited to ‘business, management and accounting’, ‘social sciences’, and ‘decision sciences’, resulting in a decrease in the number of documents to 234. In the second exclusion, documents were limited to conference papers, articles, and book chapters, thus eliminating reviews, editorials, books, and conference reviews. This criterion reduced the number of articles even further to 223. Fig. 2 details the criteria for article inclusion and exclusion.

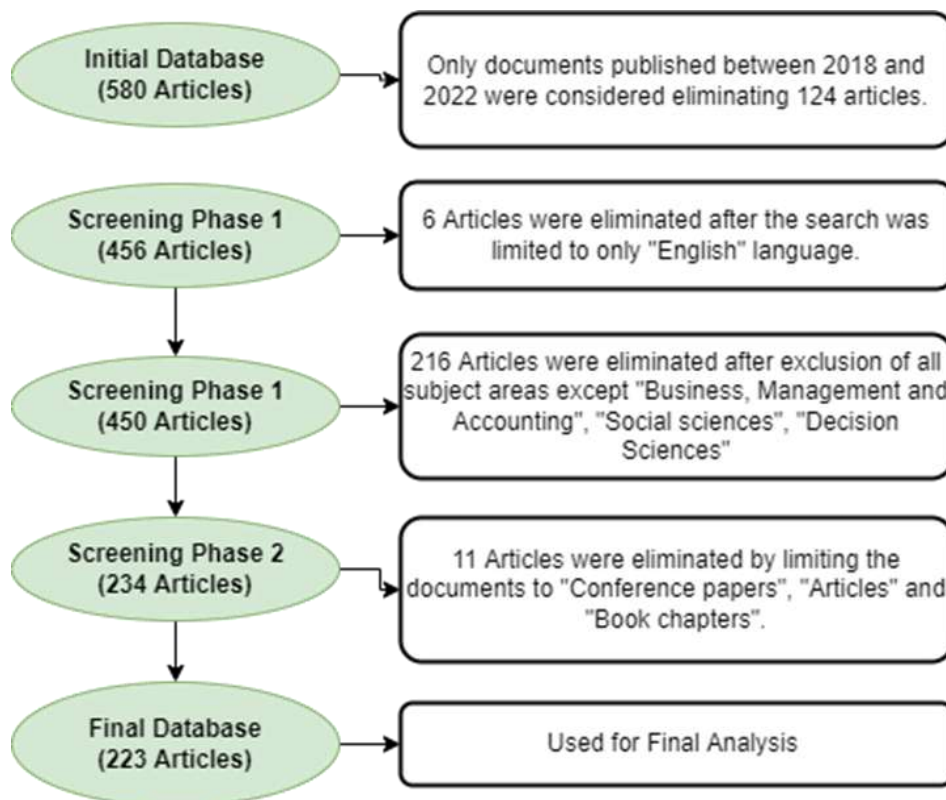

Figure 2: Inclusion and exclusion criteria.

Bibliometric analysis, a qualitative and quantitative technique, is a rapidly growing research method around the world because it allows researchers to access each other's contributions in a given field (Roig-Tierno et al., 2017). Since its inception as a statistical and modeling tool in 1969 (Pritchard, 1969), bibliometric analysis has evolved to provide a detailed view of a research field by concisely mapping the trends, allowing researchers to draw meaningful insights. Scholars have used this technique to map current marketing topics such as digital communication and IoT (Kim et al., 2021; (Miskiewicz, 2020).

This research utilizes bibliometric tools to map the social media advertising research landscape, followed by a content analysis of the most recent scholarship. After determining the chronological structure, bibliographic coupling was used to study the intellectual core. The research was carried out with VOSviewer (Visualisation of Similarity), which graphically maps the area and makes interpretation easier (Krugel et al., 2020).

**RESULTS & DISSCUSSION**

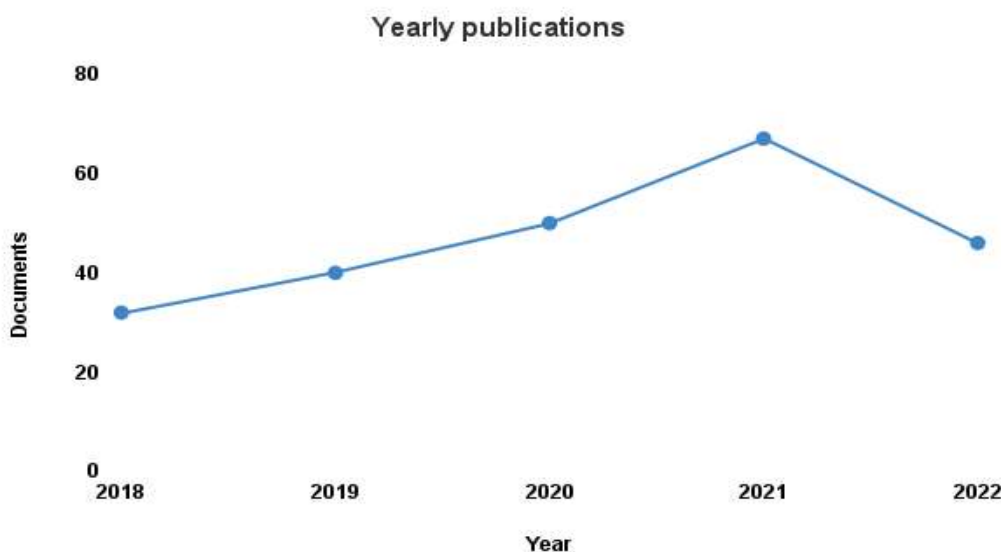

Figure 3: Documents published per year

Table 2: Most cited documents

S.no	Documents	Year	Author	Journal	DOI	TC	TCp Y
1	Advertising content and consumer engagement on social media: Evidence from Facebook	2018	Lee, D., Hosanagar, K., Nair, H.S.	Management Science	10.1287/mnsc.2017.2902	304	76
2	Engagement with Social Media and Social Media Advertising: The Differentiating Role of Platform Type	2018	Voorveld, H.A.M., Noort, G., Muntinga, D.G., Bronner, F.	Journal of Advertising	10.1080/00913367.2017.1405754	225	56.15
3	Investigating the impact of social media advertising features on customer purchase intention	2018	Alalwan, A.A.	International Journal of Information Management	10.1016/j.ijinfo mgt.2018.06.001	203	50.75
4	The impact of user personality traits on word of mouth: Text-mining social media platforms	2018	Adamopoulos, P., Ghose, A., Todri, V.	Information Systems Research	10.1287/isre.2017.0768	70	17.5
5	Is my fear of missing out (FOMO) causing fatigue? Advertising, social media fatigue, and the implications for consumers and brands	2018	Bright, L.F., Logan, K.	Internet Research	10.1108/IntR-03-2017-0112	54	13.5
6	Antecedents and consequences of customer engagement on Facebook: An attachment theory perspective	2019	Hinson, R., Boateng, H., Renner, A., Kosiba, J.P.B.	Internet Research	10.1108/JRIM-04-2018-0059	53	17.67
7	Understanding social media advertising effect on consumers' responses: An empirical investigation of tourism advertising on Facebook	2018	Hamouda, M.	Journal of Research in Interactive Marketing	10.1108/JEIM-07-2017-0101	52	13
8	Endorsement and visual complexity in food advertising on Instagram	2019	Kusumasondjaja, S., Tjiptono, F.	Journal of Enterprise Information Management	10.1108/IntR-11-2017-0459	43	14.33
9	Matching luxury brand appeals with attitude functions on social media across cultures	2020	Choi, Y.K., Seo, Y., Wagner, U., Yoon, S.	Internet Research	10.1016/j.jbusres.2018.10.003	41	20.5
10	Consumer response towards social media advertising: Effect of media interactivity, its conditions and the underlying mechanism	2020	S, S., Paul, J., Strong, C., Pius, J.	International Journal of Information Management	10.1016/j.ijinfo mgt.2020.102155	37	18.5

11	The role of social media advertising in hospitality, tourism and travel: a literature review and research agenda	2020	Chu, S.-C., Deng, T., Cheng, H.	International Journal of Contemporary Hospitality Management	10.1108/IJCHM-05-2020-0480	31	15.5
12	Visual storytelling on Instagram: branded photo narrative and the role of telepresence	2020	Lim, H., Childs, M.	Journal of Research in Interactive Marketing	10.1108/JRIM-09-2018-0115	30	15
13	Re-examining of consumers' responses toward social media advertising and purchase intention toward luxury products from 2013 to 2018: A retrospective commentary	2019	Chu, S.-C., Kamal, S., Kim, Y.	Journal of Research in Interactive Marketing	10.1080/20932685.2018.1550008	30	15
14	Ad Disclosure vs. Ad Recognition: How Persuasion Knowledge Influences Native Advertising Evaluation	2019	Jung, A.-R., Heo, J.	Journal of Interactive Advertising	10.1080/15252019.2018.1520661	27	9
15	Behavioral implications of international social media advertising: An investigation of intervening and contingency factors	2018	Johnston, W.J., Khalil, S., Le, A.N.H., Cheng, J.M.-S.	Journal of International Marketing	10.1509/jim.16.0125	26	6.5
16	Empirical Study on Perceived Value and Attitude of Millennials Towards Social Media Advertising: A Structural Equation Modelling Approach	2019	Arora, T., Agarwal, B.	Vision	10.1177/0972262918821248	24	8
17	Impulse buying in social commerce: bundle offer, top reviews, and emotional intelligence	2021	Zafar, A.U., Qiu, J., Shahzad, M., (...), Bhutto, T.A., Irfan, M.	Zafar, A.U., Qiu, J., Shahzad, M., (...), Bhutto, T.A., Irfan, M.	10.1108/APJML-08-2019-0495	20	20
18	Exploring the antecedent impact of personalised social media advertising on online impulse buying tendency	2019	Dodoo, N.A., Wu, L.	Dodoo, N.A., Wu, L.	10.1504/IJIMA.2019.097905	20	6.67
19	A consumer socialization approach to understanding advertising avoidance on social media	2020	Chinchanachokchai, S., de Gregorio, F.	Chinchanachokchai, S., de Gregorio, F.	10.1016/j.jbusres.2020.01.062	19	9.5
20	Silver lining of envy on social media? The relationships between post content, envy type, and purchase intentions	2018	Lin, R.	Lin, R.	10.1108/IntR-05-2017-0203	19	4.75

The results of a bibliometric analysis of 223 publications relevant to social media advertisements published between 2018 and 2022 are presented in this section. A timeline analysis shows the total number of papers published between 2018 and 2022 (graph. 2). Scopus database showed a dearth of social media advertising research before 2018 and a surge afterward, hence, data from 2018 onwards was considered for this study. The sharp rise could be attributed to increased industry and academic interest in the social media advertising sector. This significant growth is undeniable as social media is quickly making inroads into every facet of our lives. Notably, 79 percent of the corpus' overall research was conducted between 2018 and 2022, with 133 papers (23 percent) published in 2021 alone, indicating significant academic interest. This study was conducted in June 2022, and 70 (12% of the overall SMA research) studies have already been published in less than six months, giving hope for an even greater number of publications by the end of the year.

### Performance of Research Outlets

Table 3: Top 10 contributing Journals

Ranking	Journal	Frequency	(%)
1	Journal Of Research In Interactive Marketing	13	5.83%
2	Journal Of Interactive Advertising	8	3.59%
3	International Journal Of Internet Marketing And Advertising	7	3.14%
4	Journal Of Business Research	6	2.69%
5	International Journal Of Advertising	5	2.24%
6	International Journal Of Recent Technology And Engineering	5	2.24%
7	Internet Research	5	2.24%
8	Journal Of Digital And Social Media Marketing	5	2.24%
9	Journal Of Advertising	4	1.79%
10	Journal Of Retailing And Consumer Services	4	1.79%
Total		62	27.8%

134 distinct journals published a total of 223 publications from 2018 to 2022 in the domain of SMA. Of the 134 journals, 102 journals (76.2 percent) published just one article, 14 journals (10.5 percent) published two articles, and eight journals (5.9 percent) published five or more articles on the subject. Table 3 shows the top 10 most active journals which have contributed nearly 45 percent of the total number of documents. 'Journal of Research in Interactive Marketing' had the highest contribution in this domain. The journal published 13 research papers during the specified time period, accounting for nearly 6% of total publications. It has published five articles in the year 2021 and two articles in the first half of 2022. Other leading journals, such as 'Journal of Interactive Advertising' and 'Journal of Business Research', have published eight and six documents, respectively. Both journals had published three documents each in 2022 at the time of this study. Despite only publishing four papers between 2018 and 2022, the 'Journal of Advertising' garnered the most citations, indicating the quality of its work.

Table 4: Most cited journals

Journal	Citations
Journal of advertising	227
Journal of Research in Interactive Marketing	146



Internet Research	114
Journal of Business Research	56
Journal of Interactive Advertising	39

### Analysis of Affiliation

Out of the 449 organizations published in the SMA domain between 2018 and 2022, Fig 4 lists the top ten organizations in terms of the total number of publications. The findings show that SMA research was conducted in universities all over the world, including in Turkey, South Korea, Malaysia, Germany, and others. The University of Florida was the most prolific organization, with five publications, followed by Universiti Utara Malaysia, Loyola University of Chicago, Dongguk University, Seoul, and The University of Tennessee to round out the top five.

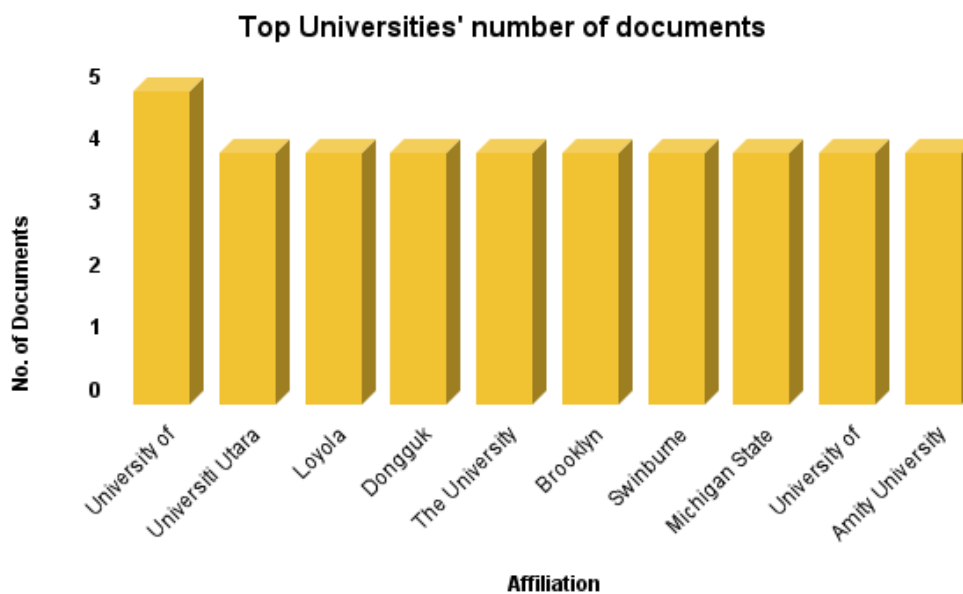

Figure 4: Affiliations with the highest publications

### Territorial Statistics and Analysis

Table 5: Top 10 contributing countries

Ranking	Country/ Territory	Frequency	(%)
1	United States	76	34.1%
2	India	28	12.5%
3	Australia	17	7.6%
4	China	17	7.6%
5	Malaysia	15	6.7%
6	United Kingdom	13	5.8%
7	South Korea	12	5.4%

8	Turkey	10	4.5%
9	Germany	8	3.6%
10	Canada	7	3.1%
Total		203	91%

Table 6: Most cited countries

Country	Citations
United States	817
Jordan	198
South Korea	167
India	154
New Zealand	112

Based on the address(es) of the author(s) as stated in the Scopus extracted data, each publication was assigned to a country or territory and an institution. Publications about SMA come from 57 different nations or territories.

The bibliometric analysis discovered that the United States had contributed the most to scholarly works on SMA, with 74 documents. Researchers from India have surged to second place in this emerging field of study with 28 documents. However, it is worth noting that in the case of collaboration with authors from other countries, the United States ranked first, while Australia ranked second (fig. 6). Despite being the second largest publisher in the field, India has only collaborated with 10 countries, falling behind the collaborative efforts of the United States (25 countries), Australia (20 countries), South Korea (18 countries), China, and the UK (16 countries each). Additionally, China, being the third highest contributor with 17 documents hasn't collaborated (16 countries) as much as other countries with fewer publications, such as Australia and Malaysia. From a continental perspective, Asia has contributed the greatest number of articles (120), followed by North America (81) and Europe (50). 21 countries from Asia have participated in research in the SMA domain, 18 from Europe, and eight from Africa. The US (74 articles) and Canada (seven articles), despite being the only North American countries to publish in the area, have the second-highest number of articles and almost as many citations (831) as Asia (835). South America and Africa, on the other hand, have made no significant contributions. This can be attributed to the countries' economic and demographic development. The majority of South American and African countries are not as developed as other contributing countries. Fig. 5 shows a continent-wise representation of the countries.

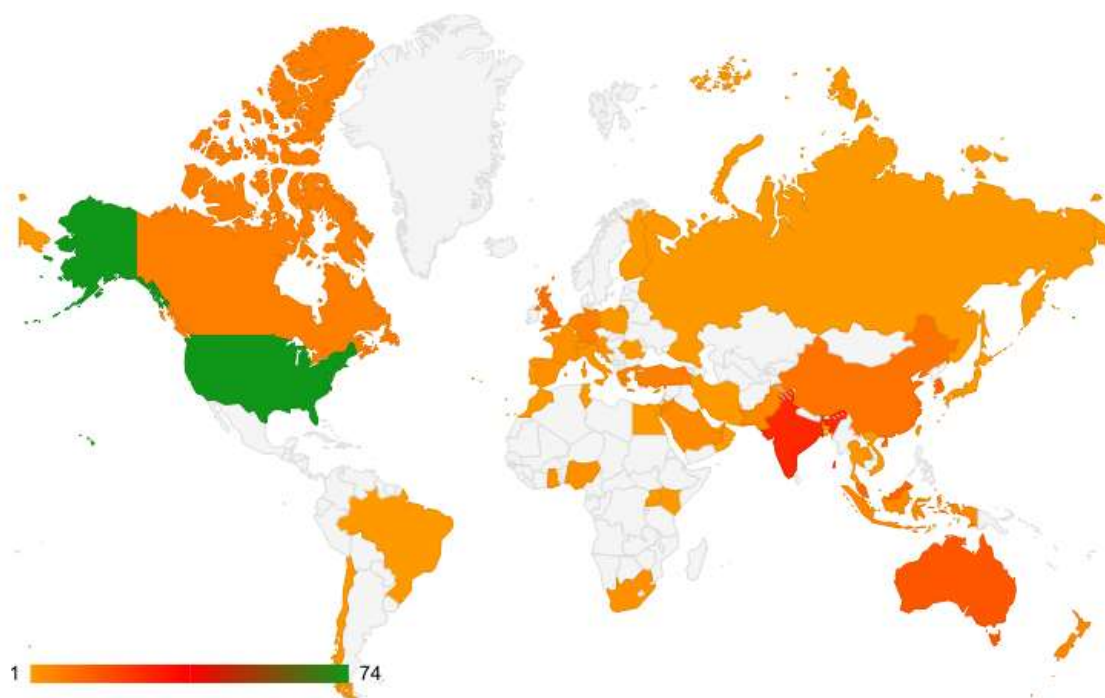

Figure 5: Continent-wise representation of countries

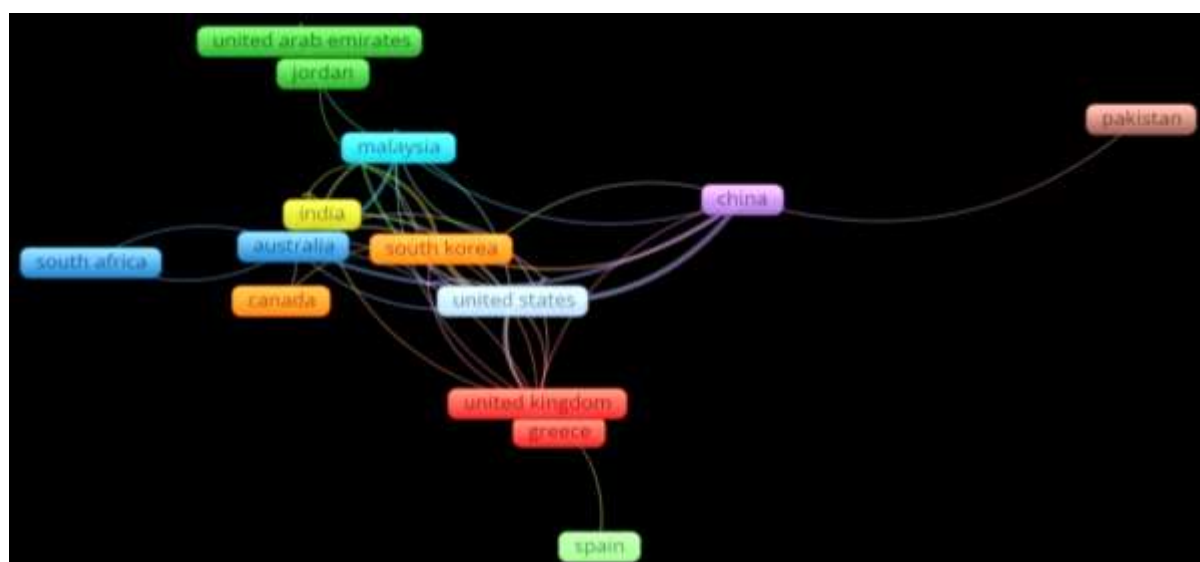

Figure 6: Collaboration between countries

**Most Productive and Influential Authors**

According to the data collected, there were 570 authors who published in the SMA domain from 2018 to 2022. Bhawna Agarwal, Taanika Arora, Yung- Kyun Choi, and Joshua Fogel were the most prolific authors, having contributed to four publications each. 33 authors have contributed at least two documents per person.

Table 7 shows the documents published by the top 10 influential authors as determined by their number of publications. The table also includes the total citation and average citation per year received by each paper. Yung- Kyun Choi, Yuri Seo, Sukki Yoon, Shuchuan Chu, and Bhawna Agarwal are the top five authors who have made significant contributions to the field of SMA in terms of the number of citations. Yuri Seo is the second-highest cited author in the field despite having published comparatively lesser documents in the domain.

Table 7: Top authors' documents

Author	year	Title	Source	DOI	TC	TCpY
Agarwal,	2020	An empirical study on determining the	International Journal of	10.4018/IJEBR.20	7	3.5

B.,		effectiveness of social media advertising: A case on indian millennials	e-Business Research	20040104		
Agarwal, B.,	2020	An empirical study on determining the effectiveness of social media advertising: A case on indian millenni	International Journal of Intelligent Enterprise	10.1504/ijie.2020.110795	3	1.5
Agarwal, B.,	2019	Empirical Study on Perceived Value and Attitude of Millennials Towards Social Media Advertising: A Structural Equation Modelling Approach	Vision	10.1177/0972262918821248	24	8
Agarwal, B.,	2018	A study of millennials's preferences for social media advertising in Delhi NCR	Indian Journal of Marketing	10.17010/ijom/2018/v48/i10/132334	18	4.5
Arora, T.	2020	An empirical study on determining the effectiveness of social media advertising: A case on indian millennials	International Journal of e-Business Research	10.4018/IJEBR.2020040104	7	3.5
Arora, T.	2020	An empirical study on determining the effectiveness of social media advertising: A case on indian millenni	International Journal of Intelligent Enterprise	10.1504/ijie.2020.110795	3	1.5
Arora, T.	2019	Empirical Study on Perceived Value and Attitude of Millennials Towards Social Media Advertising: A Structural Equation Modelling Approach	Vision	10.1177/0972262918821248	24	8
Arora, T.	2018	A study of millennials's preferences for social media advertising in Delhi NCR	Indian Journal of Marketing	10.17010/ijom/2018/v48/i10/132334	18	4.5
Choi, Y.K.	2022	Social media advertising endorsement: the role of endorser type, message appeal and brand familiarity	International Journal of Advertising	10.1080/02650487.2021.1966963	3	3
Choi, Y.K.	2020	Matching luxury brand appeals with attitude functions on social media across cultures	Journal of Business Research	10.1016/j.jbusres.2018.10.003	41	20.5
Choi, Y.K.	2019	Divergent Effects of Friend Recommendations on Disclosed Social Media Advertising in the United States and Korea	Journal of Advertising	10.1080/00913367.2019.1663320	18	6
Choi, Y.K.	2019	In “likes” we trust: likes, disclosures and firm-serving motives on social media	European Journal of Marketing	10.1108/EJM-11-2017-0883	18	6
Fogel, J.	2021	Social media advertisements with deposit contracts and fitness club/gym membership: are consumers persuaded?	Journal of Consumer Marketing	10.1108/JCM-02-2020-3621	0	0

Fogel, J.	2021	Direct-to-consumer prescription medication advertisements on social media: The role of social factors	Health Marketing Quarterly	10.1080/07359683.2021.2011998	0	0
Fogel, J.	2020	Direct-to-consumer prescription medication advertisements and use of different types of media	Journal of Electronic Commerce in Organisations	10.4018/JECO.2020100103	1	0.5
Fogel, J.	2020	Passing the bechdel test and the influence of internet and social media advertising on seeing a new movie release	International Journal of Arts Management		1	0.5
Arora, N.	2022	Decoding the Social Media Advertising Influence on Consumer Attitude and Intention	Vision	10.1177/09722629221099588	0	0
Arora, N.	2022	Predicting User Response Behaviour towards Social Media Advertising and e-WoM Antecedents	Review of Marketing Science	10.1515/roms-2022-0006	1	1
Arora, N.	2022	How Does Social Media Advertising Persuade? An Investigation of the Moderation Effects of Corporate Reputation, Privacy Concerns and Intrusiveness	Journal of Global Marketing	10.1080/08911762.2021.1980932	1	1
Chen, H.	2021	Chinese entrepreneurs' experience of social media marketing: perception, strategy and challenge	Journal of Research in Marketing and Entrepreneurship	10.1108/JRME-06-2019-0055	0	0
Chen, H.	2021	Informing, Reinforcing, and Referencing: Chinese Male Consumers' Interpretation of Luxury Advertising and Luxury Brands' Presence on Chinese Social Media	Journal of Global Marketing	10.1080/08911762.2020.1777611	3	3
Chen, H.	2021	Self-presentation and interactivity: luxury branding on social media	Journal of Product and Brand Management	10.1108/JPBM-05-2019-2368	5	2.5
Rana, M.	2022	Decoding the Social Media Advertising Influence on Consumer Attitude and Intention	Vision	10.1177/09722629221099588	0	0
Rana, M.	2022	Predicting User Response Behaviour towards Social Media Advertising and e-WoM Antecedents	Review of Marketing Science	10.1515/roms-2022-0006	1	1
Rana, M.	2022	How Does Social Media Advertising Persuade? An Investigation of the Moderation Effects of Corporate Reputation, Privacy Concerns and Intrusiveness	Journal of Global Marketing	10.1080/08911762.2021.1980932	1	1
Seo, Y.	2020	Matching luxury brand appeals with	Journal of Business	10.1016/j.jbusres.	41	20.5

		attitude functions on social media across cultures	Research		2018.10.003		
Seo, Y.	2019	Divergent Effects of Friend Recommendations on Disclosed Social Media Advertising in the United States and Korea	Journal of Advertising		10.1080/00913367.2019.1663320	18	6
Seo, Y.	2019	In “likes” we trust: likes, disclosures and firm-serving motives on social media	European Journal of Marketing		10.1108/EJM-11-2017-0883	18	6
Wang, Y.	2021	Informing, Reinforcing, and Referencing: Chinese Male Consumers’ Interpretation of Luxury Advertising and Luxury Brands’ Presence on Chinese Social Media	Journal of Global Marketing		10.1080/08911762.2020.1777611	3	3
Wang, Y.	2020	The symbolic meaning of luxury-lite fashion brands among younger Chinese consumers	Journal of Fashion Marketing and Management		10.1108/JFMM-09-2019-0204	11	5.5
Wang, Y.	2021	Self-presentation and interactivity: luxury branding on social media	Journal of Product and Brand Management		10.1108/JPBM-05-2019-2368	5	2.5
Yang, J.	2021	Building Brand Authenticity on Social Media: The Impact of Instagram Ad Model Genuineness and Trustworthiness on Perceived Brand Authenticity and Consumer Responses	Journal of Interactive Advertising		10.1080/15252019.2020.1860168	6	6
Yang, J.	2021	Demystifying congruence effects in Instagram in-feed native ads: the role of media-based and self-based congruence	Journal of Research in Interactive Marketing		10.1108/JRIM-03-2020-0048	3	3
Yang, J.	2022	Hispanics’ Response to Ethnic Targeting Ads for Unhealthy Products: Examining the Roles of Endorser Identification and Endorser–Product Matchup	Journal of Interactive Advertising		10.1080/15252019.2021.2014371	0	0

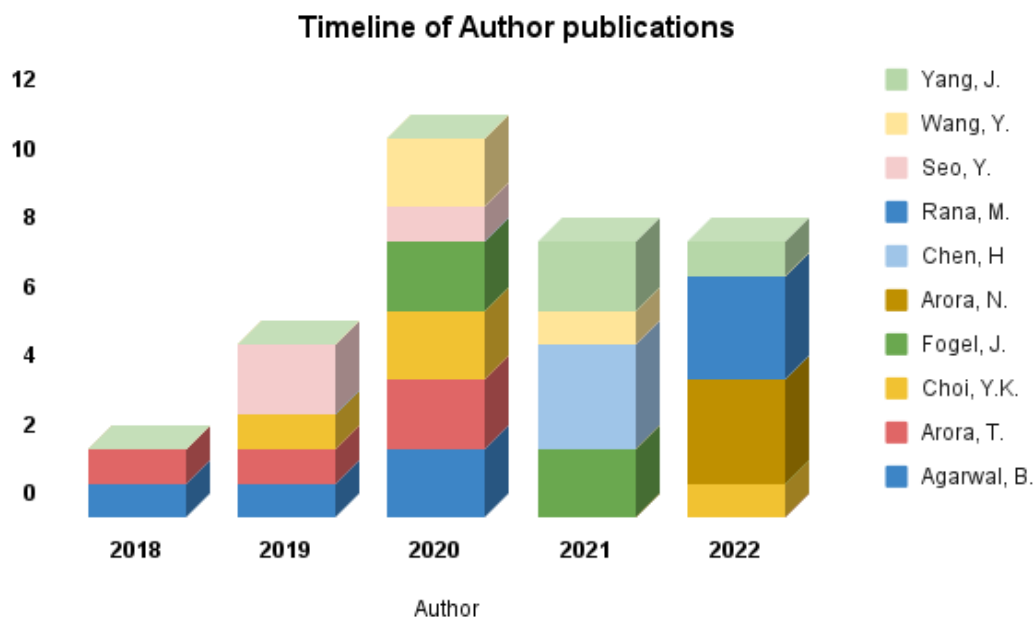

Figure 7: Timeline of Author Publications

Table 8: Most cited authors

Authors	Citations
Choi Y. K.	69
Seo Y.	67
Yoon S.	53
Agarwal B.	48
Arora T.	48

A time graph was created to understand the yearly productivity of the top 10 authors (fig. 7). The graph indicates that the top authors published the highest amount of work in 2020 and a little decline was noticeable afterward. Approximately seven of the 10 authors had published in 2020 as opposed to only four in both 2021 and 2022.

Furthermore, the collaborative relationships between different core authors can be used to discover the influential researcher groups in the field of SMA with the help of the VOSviewer tool. As illustrated in Fig. 8, a collaborative network can be divided into several groups with different colors based on cooperation strength.



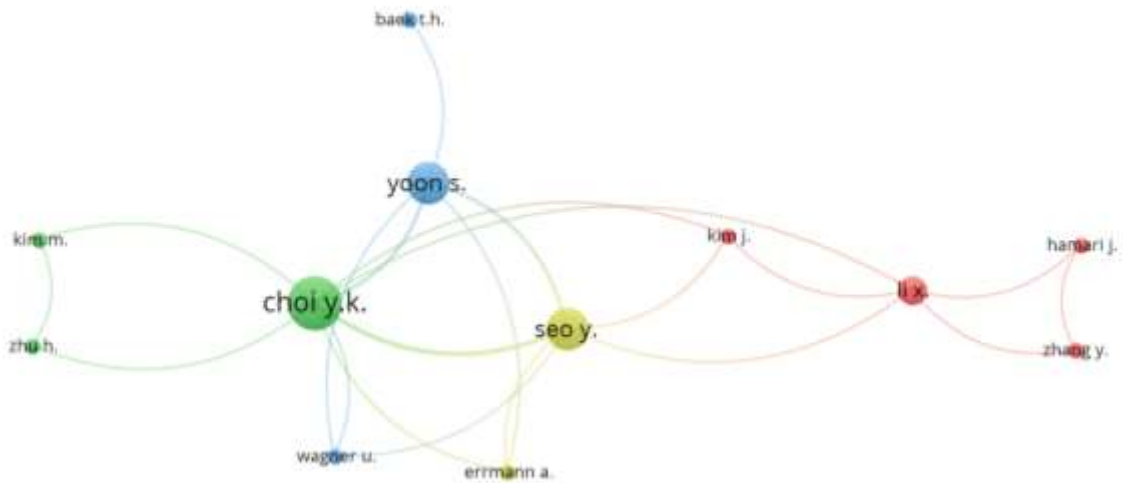

Figure 8: Collaboration between authors

Each author's frequency of occurrence is represented by the size of the circle. The line between the circles represents the core authors' collaborative relationships. It's noteworthy that the authors who have a strong collaborative relationship with one group might also have some collaborations with other groups as well. For example, Li X primarily collaborated with the red group's core authors, but he also has a strained collaborative relationship with Yung Kyun Choi, a member of the green group.

### Intellectual Structure of SMA Research

The key issues and research trends in the field can be revealed by examining the keywords used in the titles and abstracts of the publications.

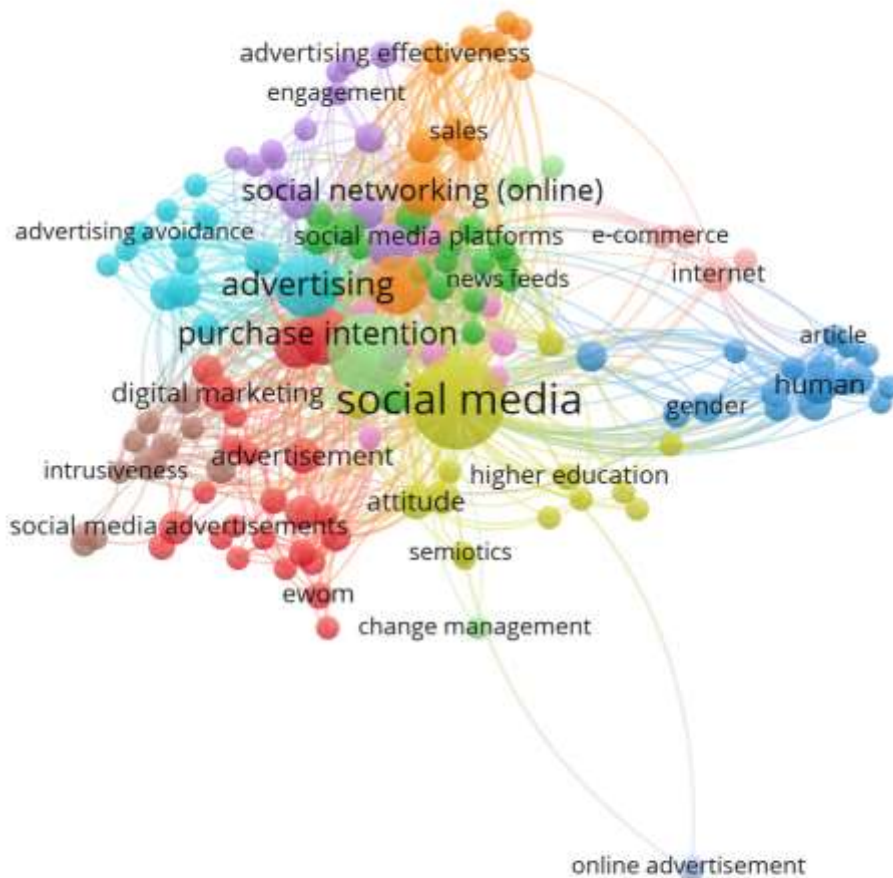

Figure 9: Network visualization of keywords



Figure 10: Word cloud of popular keywords

VOSviewer was used to extract and analyze 913 keywords from the 223 publications. 143 keywords that occurred at least twice in the SMA studies were chosen in order to find more interesting results by determining the threshold frequency of co-occurrence. Fig. 9 displays the findings of the keyword analysis. The size of the circles indicates how frequently a keyword appears in the abstracts and titles of SMA articles; the larger the size, the more frequently the term appears. A word cloud has also been created for a better understanding of the most frequently studied keywords (fig.10). Some of the keywords with the highest number of occurrences were social media, advertising, commerce, marketing, purchase intention, Facebook, sales, consumption behavior, YouTube, social influence, Instagram, branding, perception, attitudes, millennials, etc. Fig 11 shows keywords that have occurred only twice in the SMA studies in order to understand areas that need more attention. Analyzing the highly occurring keywords concludes that Facebook, YouTube, and Instagram were the most studied social media platforms. This is a chance to study other social media networks such as Snapchat, Twitter, LinkedIn, etc. that might be beneficial to investigate. Millennials were the only age group that appeared in more than five articles, giving other age groups plenty of scopes to be explored. Interactivity, learning systems, intrusiveness, emoji, influencer, neuromarketing, disclosure, eye tracking, native advertising, privacy concern, consumer neuroscience, brand attitude, brand loyalty, fake news, body image, change management, metadiscourse, semiotics, etc. are some of the areas that could be explored for further research.



Figure 11: Word cloud of keywords with fewer occurrences

Information about how closely connected two keywords are can be found in their overall distance (fig. 9). The stronger the relationship between terms, the closer their proximity. The frequency with which terms appear together in titles and abstracts is used to gauge how closely related the two terms are (Rodrigues et al., 2014). Different colors are used to distinguish between different clusters. The keywords map (fig. 9) displays how the terms used in the publications on SMA cluster together. The map illustrates five major clusters: orange cluster, red cluster, purple cluster, dark blue cluster, and light blue cluster. Table 9 represents the most frequently used keywords in different clusters that club the keywords under a broad keyword/ area.

Table 9: Variable clusters

Cluster	Broad framework	Major variables/ Keywords
Cluster 1	Consumer behaviour	Consumer attitude, Consumer responses, Advertising avoidance, Online consumer behaviour, Consumer engagement, Involvement, Interactivity, Attention, Economic and social effects, Social influence, Attitudes, Purchase intention, Consumer neuroscience
Cluster 2	Responsible marketing	Privacy concern, Sustainability, Change management
Cluster 3	Brand management	Brand image, Brand loyalty, Brand attitude, Branding, Brand equity
Cluster 4	Social media marketing	Social networking, Facebook, YouTube, Instagram, Social commerce, Emoji, Social networking sites, Personalisation, Direct-to-customer advertising, Eye tracking, News feeds, Semiotics, Digital marketing, Metadiscourse
Cluster 5	Customer perceived value	Perception, Consumer engagement, Body image, Advertising value, Informativeness, Consumer perception, Entertainment, Persuasion knowledge, Trust, Disclosure, Sentiment analysis,
Cluster 6	Business Operations	Sales, Purchasing, Marketing
Cluster 7	Marketing communications	E-WOM, Message appeal, Word of mouth
Cluster 8	Advertisement characteristics	Influencer advertising, Native advertising, Advertising effectiveness, Advertising campaign, Celebrity endorsements
Cluster 9	Research models	Structural equation modelling, Technology acceptance model
Cluster 10	Demographics	Millennials, Gender, Human, Female, Students
Cluster 11	Research design	Surveys, Questionnaire, Online questionnaire, Article, Empirical study
Cluster 12	Research Area	Learning systems, Public health, Higher education, Digital literacy, Digital storage, Luxury brands, Covid 19, Neuromarketing, Psychology

Fig. 12 displays the keyword analysis of the publications on SMA but with timing information. A term's colour denotes its typical year of publication. By averaging the publishing years of all documents with the term in the title or abstract, one can get the average publication year of a term.

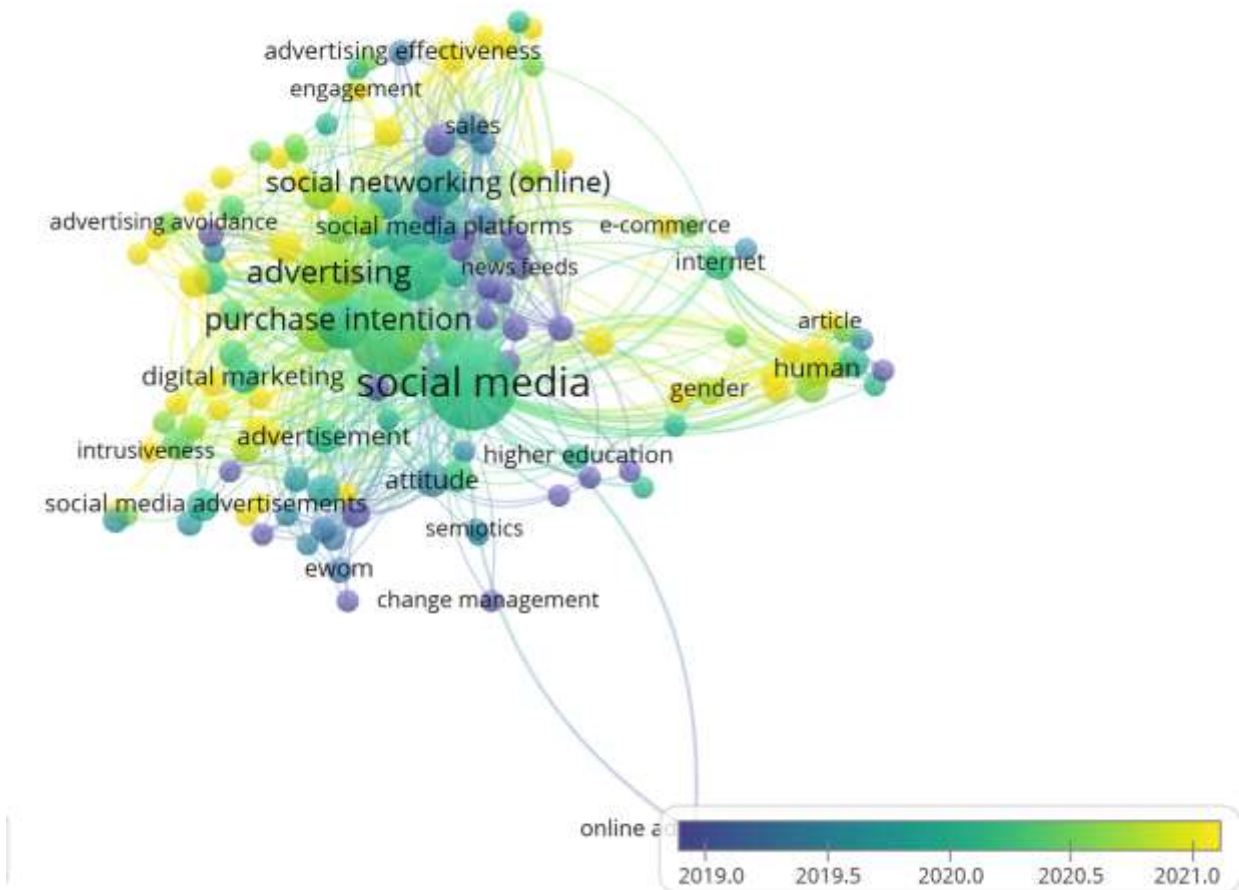

Figure 12: Timeline map of keywords

Looking at the time periods, a lot of SMA variables such as social media, purchase intention, social media advertising, consumer behaviour, Facebook, social networking (online), psychology, consumer neuroscience, influence, and persuasion were studied around 2020. Studies in 2020 mainly focused on consumer behaviour-related terms. In 2019, most studies were based on keywords such as e-wom, semiotics, surveys, advertising effectiveness, purchasing, and sales, and the majority of research around 2021 focused on keywords like message appeal, engagement, economic and social effects, structural equation modelling, cross-sectional study, and adult.

To summarise the keyword analysis section, the map of network visualisation (fig. 9) indicates that areas such as consumer behaviour, consumer psychology, brand equity, purchase decisions, consumer attitude and experience have been in trend in the last five years of SMA research.

The time map indicated that recent studies are exploring keywords like sustainability, message appeal, influencer marketing, eye tracking, emoji, native advertising, intrusiveness, meta-discourse, privacy concern, etc. As a future scope, these variables can be studied in more depth and with connections to other interesting areas. Some keywords that were studied more in the early years, such as sentiment analysis, advertising value, celebrity endorsement, direct-to-consumer advertising, social commerce, persuasion knowledge, and content analysis, still have scope for further studies.

### CONCLUSION

This paper provides an assessment of the worldwide research trends in SMA publications published between 2018 and 2022. The SMA field is in its growth phase and has shown significant growth over the last five years, with over 79% of all SMA articles published during this time. The old marketplaces are being replaced by social media and digital marketing; therefore, market trends shift quickly. Further research on social media advertising is encouraged to stay up to date with the changes in the online marketing industry.

The research includes 223 papers on SMA from 570 authors across 134 journals, 57 nations or territories, and 449 organizations. The study utilizes content analysis and the bibliometric tool 'VOSviewer' to map the current state of SMA research and its potential future advancement. The 'Journal of Interactive Marketing' stands out for publishing the highest number of articles (13) and the 'Journal of Advertising' stands out for receiving the highest number of citations. The top five countries with the most publications were the United States, India, Australia, China, and Malaysia, with the US topping the list with 74 (33%) papers, receiving 817 citations, and having collaborated with 25 different countries. With 120 publications and



835 citations, Asia leads the continents in terms of research output. On the other side, North America, which published only 67 percent (81) of what Asia did, garnered nearly as many citations (831) as Asia. The most productive authors were Bhawna Agarwal, Taanika Arora, Yung- Kyun Choi, and Joshua Fogel, who each contributed to four articles. Yung- Kyun Choi and Yuri Seo were the most cited authors, with 69 and 67 citations, respectively. Keywords such as social media, advertising, commerce, marketing, purchase intention, facebook, sales, consumption behavior, youtube, social influence, Instagram, branding, perception, attitudes, millennials, etc. had occurred more often in the SMA research. On the other hand, keywords like interactivity, learning systems, intrusiveness, emoji, influencer, neuromarketing, disclosure, eye tracking, native advertising, privacy concerns, consumer neuroscience, brand attitude, brand loyalty, fake news, body image, change management, metadiscourse, semiotics, etc need more exploration. The three social media sites that have received the most attention were Facebook, Instagram, and YouTube. Millennials, on the other hand, were the most studied age group, which leaves scope for other age groups to be explored as well. Some of the top clusters forming the core of the SMA research were ‘Consumer behavior’, ‘Responsible marketing’, ‘Brand management’ and ‘Customer perceived value’.

Academics and practitioners will benefit from the bibliometric evaluation of SMA research in a variety of ways. The first benefit of this study is that it will provide academic researchers and social media marketers with information about the development, trends, and past of SMA. This study will also include information on the SMA domains that have received the most research, allowing academics to pinpoint areas that still need additional investigation.

It is important to address some of the limitations of this study. The search was restricted to Scopus-listed papers. Even though Scopus is one of the biggest databases in the world, it certainly does not include all papers in the SMA subject. There are other worldwide databases that could have been utilised, such as PubMed, Dimensions, or Web of Science. A database of just 223 papers was used for the current study, which was focused on the years 2018 to 2022. This may just present a fragment of the dynamics of SMA research. In the future, a study with a longer time span and larger datasets can be conducted to reveal further SMA research sub-fields. The study was carried out in the middle of 2022; the rest of the year may reveal a completely different pattern from the first half. Studies focusing on specific study fields in connection to SMA can reveal even more intriguing arenas and may open newer worlds of research topics as compared to this work, which investigated social media advertising across disciplines to give a larger perspective of the trends. Interactivity, learning systems, intrusiveness, emoji, big data, influencers, neuromarketing, disclosure, eye tracking, native advertising, privacy concerns, consumer neuroscience, brand attitude, brand loyalty, fake news, body image, change management, metadiscourse, semiotics, etc are some of the areas that could be explored for further research as they have fewer occurrences in the earlier studies. The most popular social media platforms to study under SMA have been Facebook, YouTube, and Instagram; other platforms like Snapchat, Twitter, etc., have received less attention. Since other platforms are currently also highly active with advertising, it is essential to look at them in order to better comprehend the digital marketplaces and their functioning. The millennial generation has been the subject of many studies; studies on other generations, such as Gen Z, Gen X, boomers, etc., are few and far between. Future research should take these age groups into account in order to understand how different age groups respond to social media advertising. The majority of studies have a female demographic focus. A global average of 45.6% of women and 54.4% of men use social media (Dean, 2021), hence studies with a male demographic are as necessary as those with females.

## REFERENCES

- Ahmed, Q. M., & Raziq, D. M. M. (2017). *The Social Media Advertising Model (SMAM): A Theoretical Framework*. 03, 28.
- Aria, M., & Cuccurullo, C. (2017). bibliometrix: An R-tool for comprehensive science mapping analysis. *Journal of Informetrics*, 11(4), 959–975. <https://doi.org/10.1016/j.joi.2017.08.007>
- Baas, J., Schotten, M., Plume, A., Côté, G., & Karimi, R. (2020). Scopus as a curated, high-quality bibliometric data source for academic research in quantitative science studies. *Quantitative Science Studies*, 1, 1–10. [https://doi.org/10.1162/qss\\_a\\_00019](https://doi.org/10.1162/qss_a_00019)
- Beig, F.A., & Khan, M. F. (2018). Impact of Social Media Marketing on Brand Experience: A Study of Select Apparel Brands on Facebook. *Vision: The journal of Business Perspective*, 22(3), 264-275. <https://doi.org/10.1177/0972262918785962>
- Carlson, L. (2015). The *Journal of Advertising*: Historical, Structural, and Brand Equity Considerations. *Journal of Advertising*, 44(1), 80–84. <https://doi.org/10.1080/00913367.2014.993487>
- Chu, S.-C., Deng, T., & Cheng, H. (2020). The role of social media advertising in hospitality, tourism and travel: A literature review and research agenda. *International Journal of Contemporary Hospitality Management*, 32(11), 3419–3438. <https://doi.org/10.1108/IJCHM-05-2020-0480>
- Dean, B. (2021, October 10). *How Many People Use Social Media in 2022? (65+ Statistics)*. Backlinko. <https://backlinko.com/social-media-users>
- Donthu, N., Kumar, S., Mukherjee, D., Pandey, N., & Lim, W. M. (2021). How to conduct a bibliometric analysis: An overview and guidelines. *Journal of Business Research*, 133. <https://doi.org/10.1016/j.jbusres.2021.04.070>
- Faber, R. J. (2015). Peeking Under the Curtain and Over the Horizon: The Reflections of Another Former Editor. *Journal of Advertising*, 44(3), 289–295. <https://doi.org/10.1080/00913367.2015.1045155>
- Faruk, M., Ching, U., & Chowdhury, K. (2021). Mental Health and Well-being of Indigenous People during the COVID-19 Pandemic in Bangladesh. *Heliyon*, 7, e07582. <https://doi.org/10.1016/j.heliyon.2021.e07582>
- Hanaysha, J. (2016). Examining the Effects of Employee Empowerment, Teamwork, and Employee Training on Organizational Commitment. *Procedia - Social and Behavioral Sciences*, 229, 298–306. <https://doi.org/10.1016/j.sbspro.2016.07.140>
- How Many People Use Social Media in 2022? (65+ Statistics)*. (2021, October 10). Backlinko. <https://backlinko.com/social->

media-users

- Huo, H., Liu, Z., & Min, Q. (2020). Social media advertising reactance model: A theoretical review. *Internet Research, ahead-of-print*. <https://doi.org/10.1108/INTR-02-2020-0072>
- Irfan, A., Rasli, A., Sami, A., & Liaquat, H. (2017). Role of social media in promoting education tourism. *Advanced Science Letters*, 23(9), 8728–8731.
- Jung, J., Shim, S. W., Jin, H. S., & Khang, H. (2016). Factors affecting attitudes and behavioural intention towards social networking advertising: A case of Facebook users in South Korea. *International Journal of Advertising*, 35(2), 248–265. <https://doi.org/10.1080/02650487.2015.1014777>
- Kaplan, A. M., & Haenlein, M. (2010). Users of the world, unite! The challenges and opportunities of Social Media. *Business Horizons*, 53(1), 59–68.
- Keller, K. L. (1993). Conceptualizing, Measuring, and Managing Customer-Based Brand Equity. *Journal of Marketing*, 57(1), 1–22. <https://doi.org/10.1177/002224299305700101>
- Khaleeli, M. (2020). THE EFFECT OF SOCIAL MEDIA ADVERTISING AND PROMOTION ON ONLINE PURCHASE INTENTION. *Journal of Critical Reviews*, 7.
- Kim, J., Kang, S., & Lee, K. H. (2021). Evolution of digital marketing communication: Bibliometric analysis and network visualization from key articles. *Journal of Business Research*, 130, 552–563. <https://doi.org/10.1016/j.jbusres.2019.09.043>
- Knoll, J. (2016). Advertising in social media: A review of empirical evidence. *International Journal of Advertising*, 35(2), 266–300. <https://doi.org/10.1080/02650487.2015.1021898>
- Kruggel, A., Tiberius, V., & Fabro, M. (2020). Corporate Citizenship: Structuring the Research Field. *Sustainability*, 12(13), 5289. <https://doi.org/10.3390/su12135289>
- Lai, Y., & Ren, J. (2016). The effect of social media advertising on consumer-based brand equity and behavioral intention: A case of we chat news feed advertisements in China. *2016 International Conference on Management Science and Engineering (ICMSE)*, 1716–1722. <https://doi.org/10.1109/ICMSE.2016.8365641>
- Miskiewicz, R. (2020). *Internet of Things in Marketing: Bibliometric Analysis*. <https://essuir.sumdu.edu.ua/handle/123456789/80042>
- Okazaki, S., Rubio, N., & Campo, S. (2012). Do Online Gossipers Promote Brands? *Cyberpsychology, Behavior, and Social Networking*. <https://doi.org/10.1089/cyber.2012.0283>
- Pritchard, A. (1969). *Statistical Bibliography; An Interim Bibliography*.
- Raji, R. A., Rashid, S., & Ishak, S. (2019). The mediating effect of brand image on the relationships between social media advertising content, sales promotion content and behavioural intention. *Journal of Research in Interactive Marketing*, 13(3), 302–330. <https://doi.org/10.1108/JRIM-01-2018-0004>
- Rodrigues, S. P., van Eck, N. J., Waltman, L., & Jansen, F. W. (2014). Mapping patient safety: A large-scale literature review using bibliometric visualisation techniques. *BMJ Open*, 4(3), e004468. <https://doi.org/10.1136/bmjopen-2013-004468>
- Roig-Tierno, N., Gonzalez-Cruz, T. F., & Llopis-Martinez, J. (2017). An overview of qualitative comparative analysis: A bibliometric analysis. *Journal of Innovation & Knowledge*, 2(1), 15–23. <https://doi.org/10.1016/j.jik.2016.12.002>
- Taylor, D., Lewin, J., & Strutton, H. (2011). Friends, Fans, and Followers: Do Ads Work on Social Networks? *Journal of Advertising Research*, 51, 258–275. <https://doi.org/10.2501/JAR-51-1-258-275>
- Zupic, I., & Čater, T. (2015). Bibliometric Methods in Management and Organization. *Organizational Research Methods*, 18(3), 429–472. <https://doi.org/10.1177/1094428114562629>

## Stakeholder Behaviors of Peer-to-Peer Accommodation: A Systematic Review (2008-2022)

Xiaorong Wang<sup>1</sup>  
Yifan Ding<sup>2</sup>  
Yinghua Huang<sup>3,\*</sup>

\*Corresponding author

<sup>1</sup> Associate Professor, Chongqing Technology and Business University, Chongqing, China, xrw@ctbu.edu.cn

<sup>2</sup> Master Student, Chongqing Technology and Business University, Chongqing, China, 2021336011@email.ctbu.edu.cn

<sup>3</sup> Associate Professor, San José State University, San José, USA, yinghua.huang@sjsu.edu

### ABSTRACT

Focusing on multi-stakeholder consuming psychology and behavior research in peer-to-peer (P2P) accommodation, the authors conduct a systematic review of research over past 15 years (2008-2022) based on 360 papers in the WOS database. Through the perspective of service ecosystem, this paper aims to convey the structure of knowledge on this ever-evolving subject. The key stakeholders in the P2P accommodation ecosystem include consumers, hosts, platforms, the government, and community residents, and the authors sort through the psychology and behaviors of each in turn and provide a framework for research content to identify the connections among them. This paper fills the gaps of the existing literature reviews and proposes new directions for future research about P2P accommodation.

*Keywords:* P2P accommodation, stakeholder behaviors, systematic review, service ecosystem.

### INTRODUCTION

The sharing economy is a phenomenon as events in which one or more people consume economic goods or services by engaging in joint activities with others (Belk, 2007; Ganapati & Reddick, 2018). P2P accommodation is one of the hottest trends representing the sharing phenomenon in the hotel and tourism industry (Sainaghi, 2020). P2P accommodation (i.e., Airbnb) has drastically changed travelers' consumption habits due to its excellent performance in offering authentic experiences and saving cost (Carroll & Kovacs, 2018; Kabadayi, Aksoy, Yazici, & Alan, 2022). At the same time, it is becoming increasingly prominent for P2P accommodation' adverse impact on the hotel industry, housing markets and communities (Xie & Kwok, 2017). Given the dual impact of P2P accommodation, it is attracting academic attention of diverse areas including tourism and hospitality, marketing, and information systems (Dolnicar, 2019; Klarin & Suseno, 2021; Vila-Lopez & Kuster-Boluda, 2022).

It is an appropriate time to comb the generated literature on P2P accommodation over the past 15 years. Although a few literature reviews on the sharing economy and P2P accommodation have been published, the following defects still exist in general: firstly, prior reviews concentrate on the common content of sharing economy or P2P accommodation, while a key topic focusing on consuming psychology and behavior of P2P accommodation is still lacking. Secondly, although past reviews have identified many research themes or clusters of current research, these themes are fragmented and we do not know whether they are independent or interrelated, making it difficult to understand P2P accommodation from a systemic perspective. To fill the gaps, this article demonstrates a systematic review focusing on consuming psychology and behavior research in P2P accommodation to answer the following research questions (RQs):

1. What is the current state of researches on consuming psychology and behavior in P2P accommodation (RQ1)?
2. What theories, contexts and methods were used in research in this domain (RQ2)?
3. What are the gaps and areas for future research (RQ3)?

This paper has three theoretical contributions. First, it focuses on the psychology and behavior of online P2P accommodation, an area that scholars have extensively studied but never systematically summarized. Second, the framework-based approach breaks through the limitations of previous research and investigates the current knowledge structure from a holistic perspective. Third, it identifies the opportunities for future research on sharing economy and P2P accommodation.

### RESEARCH METHOD

This paper follows a framework-based approach to perform a systematic review of consuming psychology and behavior research in P2P accommodation. Literature process adopts Preferred Reporting Items for Systematic Reviews and Meta-Analyses (PRISMA) with four stages (identification, screening, eligibility, and including) (Moher, Liberati, Tetzlaff, Altman, & Group, 2009). In the first step, we used terms such as "peer-to-peer accommodation" or "sharing accommodation" on the Web of Science to search for journal articles published between 2008 and 2022 in February 2023. In the returned results, we excluded literature



from significantly unrelated fields such as architecture and medicine, and preliminarily identified 1867 studies with P2P accommodation. In the second step, we reduced the number of samples to 1775 by screening from three aspects: research type, publication time, and duplicates. In the third step, we picked out the articles which were from journals that at least were at the rank of 2 in the ABS list (Association of Business Schools Academic Journal Quality Guide), checked their topic relevance manually, and got 360 articles. Finally, a keyword retrieval was conducted again in the target journals to guarantee the comprehensiveness of the data collection, and no missing research was found. Therefore, a total of 360 articles are used for the subsequent analysis.

### THE STATE OF RESEARCHES

As many published studies related to platforms or the sharing economy have applied (Parente, Geleilate, & Rong, 2018; Xu, Hazée, So, Li, & Malthouse, 2021), this paper outlines a service ecosystem framework that incorporate multi stakeholders to systematically organize current research and identified several themes (see figure 2).

#### Actors Involved in The P2PA Platform Ecosystem

Through reading and summarizing the literature, we found that the current research on psychology and behavior in P2P accommodation mainly involves P2P accommodation platform provider, service providers, consumers, governments and community residents, who together constitute the P2P accommodation platform ecosystem (Figure 1). among them, the platform, hosts and consumers as direct participants in P2P accommodation activities together form the focal scale of the ecosystem, the government and community residents constitute the political, economic, and cultural environment in which P2P accommodation is rooted. They do not directly participate in, but affecting and being affected by P2P accommodation activities.

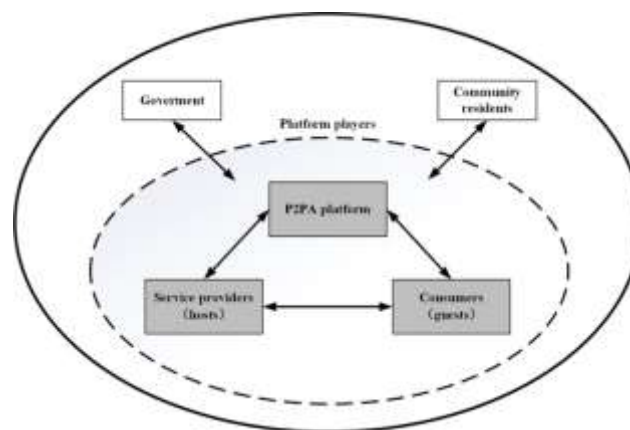

Source: This study.

Figure 1: Actors involved in the P2PA platform ecosystem.

#### Consumer Psychology and Behavior

The three-stage model of service consumption was applied to review the consumer psychology and behavior research in P2P accommodation (Tsotsou & Wirtz, 2015). In the pre-purchase stage, consumers first decide whether to participate in P2P accommodation, then initiate information search and evaluate several alternatives accordingly. For participation, we identify two main drivers: utilitarian motivation (i.e., economic benefits, home benefits) (Lu, Mody, & Andajigarmaroudi, 2020; So, Oh, & Min, 2018; Tamilmani, Rana, Nunkoo, Raghavan, & Dwivedi, 2022) and hedonistic motivation (i.e., the desire for authenticity, the need for social interactions, the enjoyment, pleasure, and reducing loneliness) (Farmaki & Stergiou, 2019; Guttentag, Smith, Potwarka, & Havitz, 2018; Paulauskaite, Powell, Coca-Stefaniak, & Morrison, 2017; So et al., 2018; Tamilmani et al., 2022). In addition, we also found two limiting factors (distrust and perceived risks) (Marth, Hartl, & Penz, 2022; So et al., 2018). For information searching and evaluating, existing literatures focused on understanding how host and listing related information that generated from platforms (P. Luo, Ma, Zhang, Liu, & He, 2021; Ma, Cui, Xiao, & Zhao, 2022), hosts (Cho, Park, & Kim, 2017; Li, Peng, Ma, & Zhou, 2022), and other consumers (Liu, Lai, Wu, & Luo, 2022) affect consumers' preference.

In the service encounter stage, consumers co-create value and co-produce a service while evaluating the service experience (Tsotsou & Wirtz, 2015). The consumers' interactions with service scenarios (Shi, Gursoy, & Chen, 2019; Suess, Kang, Dogru, & Mody, 2020), hosts (Zhang, Wang, & Cheng, 2020), and other consumers (Shi et al., 2019) have considerable effects on shaping consumer experience. However, the conclusion regarding the importance of the experience dimension is controversial (Sthapit & Jimenez-Barreto, 2018; F. Xu, La, Zhen, Lobsang, & Huang, 2019). Furthermore, previous studies suggested that consumers exhibit unethical and civilized behavior during sharing process (Peng, Wang, Huang, & Wang, 2022).

For the post-service stage, existing literature mainly focused on consumer satisfaction on sharing experience. Most scholars have identified the antecedents of satisfaction including enjoyment, economic benefits, social connections, reputation, trust, etc. (Shin, Fan, & Lehto, 2021; F. Xu et al., 2019; Ye, Chen, & Paek, 2022). In addition, some researchers pay attention to consumer loyalty (Priporas, Stylos, Vedanthachari, & Santiwatana, 2017; Shin et al., 2021), repurchase intention (C. H. Wang & Jeong,

2018; Ye et al., 2022), and rating and commenting behavior (Bridges & Vasquez, 2018; Y. Luo & Tang, 2019; Zhu, Lin, & Cheng, 2020).

### **Host Psychology and Behavior**

Hosts take on the dual roles of accommodation resource providers and accommodation service providers. In the pre-purchase stage, the hosts first consider whether share their space. When hosts decide to participate in P2P platforms, they display the listings of shared rooms or houses and personal information, then accept suitable guests after receiving the booking request. In the existing literature, many studies on host participation have identified a series of promoting (J. Chung, Johar, Li, Netzer, & Pearson, 2022; Farmaki & Stergiou, 2019), hindering (Mahadevan, 2019; Teubner & Flath, 2019), and influencing factors (Gerwe, Silva, & de Castro, 2022). As for the marketing strategies, previous research suggests that the information disclosure of housing listings and hosts characteristic affect consumers' perception and purchase decision-making (Y. Chung & Sarnikar, 2022; Pera, Viglia, & Furlan, 2016; Tussyadiah & Park, 2018). In addition, professional and amateur hosts have different pricing strategies and check-in rules (Casamatta, Giannoni, Brunstein, & Jouve, 2022; Koh, Belarmino, & Kim, 2020; K. R. Xie & Mao, 2019). For screening P2P accommodation guests, it is thought to help reduce security risk (W. F. Wang, Su, Chan, & Qi, 2020), whereas it has also raised concerns about discrimination (Cui, Li, & Zhang, 2020).

In the service encounter stage, the host provides unique physical resources and human resources for the value creation in sharing accommodation. During the transaction, the host has self-perception of moral responsibility and guide hospital practice accordingly (Farmaki, Stergiou, & Kaniadakis, 2022), displaying different conversation, interaction, and affinity strategies (Qiu, Chen, Bi, Lyu, & Li, 2022; Scerri & Presbury, 2020), and they also have certain expectations for guests (Xue, Leung, & Ma, 2022).

In the post service stage, some studies have explored the attitude and behavior of hosts after sharing accommodation. For example, the rare researches have examined the effects of host-guest interaction on satisfaction (Moon, Miao, Hanks, & Line, 2019) and influencing factors of hosts re-entering market (Belarmino & Koh, 2022). In addition, host practices in the post-service phase also include police compliance (Park, Kwak, & Lee, 2019), generating reviews (Liang, Zhang, Li, Li, & Yu, 2021), and community supporting (Park et al., 2019).

### **Platform Behavior**

The platform company plays a connecting role in the P2P accommodation service ecosystem, not only providing convenience and guidance for the sharing activities of both supply and demand side, but also being discussed and supervised by participants outside the platform. Previous research on P2P accommodation platforms mainly focuses on the following two aspects.

First, P2P accommodation platforms promote transactions to maximize profits. The platform tries to attract more users to join it. In the aspect of user management, trust is a very crucial factor (Tamilmani et al., 2022; W. F. Wang et al., 2020; Y. C. Wang, Asaad, & Filieri, 2020). Trust contains interpersonal, organizational and systems level (Calabro, Nisar, Torchia, & Tseng, 2022). Among them, establishing a reputation mechanism for interpersonal trust is a hot issue. Take Airbnb's simultaneous disclosure policy for example, scholars have discovered its impact on ratings, the number of comments, content, emotions, and adverse selection behavior (Fradkin, Grewal, & Holtz, 2021; Mousavi & Kexin, 2022). Monitoring mechanism is also a major measure of user management, which can significantly reduce users' perceived risk (Marth et al., 2022).

Second, some studies have focused on the platform's corporate social responsibility, which aims to relief the negative social impacts brought by P2P accommodation. For example, platform self-discipline has led to a reduction of crime rates (Han, Wang, Ahsen, & Wattal, 2021). At the same time, participating in environmental protection and advocating CSR can help restore trust and enhance platform reputation (Chuah, Rasoolimanesh, Aw, & Tseng, 2022).

### **Government Behavior**

In view of the impact that the development of P2P accommodation has had on the long-term rental, residential, and traditional hotel markets, as well as the nuisance that it has caused to the residents of the community, the governments of various countries and regions have introduced different regulatory policies to mitigate these negative impacts (Nieuwland & van Melik, 2020). Current research mainly focuses on the effectiveness of regulatory policies. Most studies have demonstrated the significant inhibitory effect of regulations on the supply and income of P2P accommodation (Chen, Huang, & Tan, 2021; Vinogradov, Leick, & Kivedal, 2020; Yeon, Kim, Song, & Kim, 2022). Some studies have investigated the effects of P2P accommodation regulation on other urban departments such as long-term rental, hotels, and real estate (Chen et al., 2021; Falk & Yang, 2021; Furukawa & Onuki, 2022). In addition, prior research pointed out that the implementation of regulation should be flexible and adapt to local conditions (Grimmer, Vorobjovas-Pinta, & Massey, 2019).

### **Community Residents' Psychology and Behavior**

P2P accommodation has invaded residential areas and changed the daily life for many community residents. Scholars have investigated empirically the impacts of P2P accommodation on community residents. The research results show that residents have a perception of both positive and negative impacts in the economic, environmental, and sociocultural aspects (Jordan & Moore, 2018; Muschter, Caldicott, von der Heide, & Che, 2022; Stienmetz, Liu, & Tussyadiah, 2022). Most research consider that P2P accommodation have positive roles on community residents (Stergiou & Farmaki, 2020; Stienmetz et al., 2022). The

perceived positive (negative) impact directly promotes (suppresses) residents' support for Airbnb and the tourism industry (Makarand Mody, Suess, & Dogru, 2019; M. Mody, Suess, & Dogru, 2021). Besides, emotional solidarity between residents and visitors is also an antecedent to platform support (Suess, Woosnam, & Erul, 2020), and plays an important role in the host-guest relationship and residents' support to hosts (J. Y. Chung, 2017; Suess, Woosnam, et al., 2020).

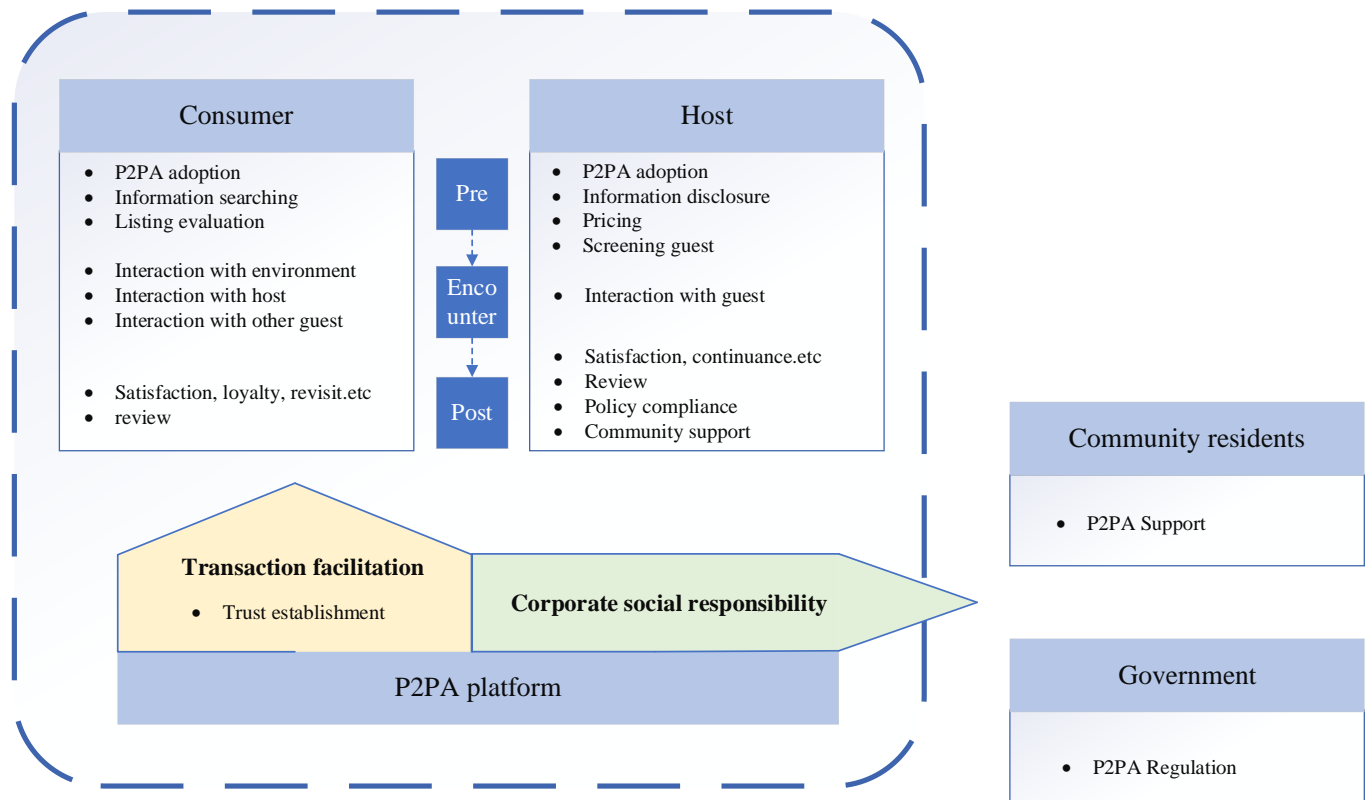

Source: This study.

Figure 2: Summary framework of stakeholders' behavior research in P2PA.

### THEORIES, CONTEXTS AND METHODS

Theories help scholars to search for answers to research-related questions and meeting their objectives. This review has found the usage of a large number of theories guiding the research on the psychology and behavior in P2P accommodation, presenting two characteristics. One is that the ratio of the number of articles utilizing a theory to the number of theories employed has reached 1.13:1, indicating that a large number of theories are rare. Scholars have innovatively incorporated specific theories into P2P accommodation research, thus expanding the scope of their application. However, viewed from another angle, it proves that research on the psychology and behavior in P2P accommodation excessively emphasizes the use of new theories, neglecting the advancement of existing theories. Prioritizing the breadth of research over its depth, hindering the development of higher-level knowledge. The other is that social exchange theory is the most popular theory, effectively explaining the interaction among individuals with overlapping interests. It is particularly used in studying residents' attitudes towards P2P accommodation, and along with Prospect theory and the theory of planned behavior, constitutes the top three most applied theories. Finally, there are still about half of the articles base on no theory and rely solely on literature to support their proposed assumptions, yet they are still accepted in mainstream academic journals. Additionally, no article has proposed a new theory or framework. It still seems difficult to devise original theories in the context of P2P accommodation.

This review considers two contexts across 360 studies: platform and region. Regarding platforms, most articles have taken Airbnb platform as the research background (80.21%). As a pioneer in the P2P accommodation industry, Airbnb has led the way over other platforms. And several mechanism reforms in the process of expansion provide unique conditions for the study of platform behavior. Up to now, Airbnb has reached a high level of maturity, boasting a vast collection of listings, reviews, identities, and other data related to hosts and consumers, making it a fertile source for scholars to conduct psychology and behavior research. Apart from Airbnb, a few papers consider its local competitors, such as Xiaozhu (4.69%) and Tujia (2.08%) in China. As a free P2P accommodation platform, Couchsurfing has always had a place in research involving sharing ethics, but these studies are relatively rare. In terms of geographical distribution, America accounts for the highest proportion of nearly half. Although the discussion rate of individual European countries is not high, they often appear together as a whole, accounting for a significant proportion. In these two areas where P2P accommodation first flourished, especially America, the birthplace of Airbnb, P2P accommodation has become commonplace and highly accepted by the public. Notably, studies based in China account for 19.44%, ranking second among individual countries, indicating that the rapid development of P2P accommodation in China is attracting attention.

The vast majority of studies on the consuming psychology and behaviors in P2P accommodation employ empirical methods, predominantly in four aspects: conceptual research, qualitative research, quantitative research, and mixed method research. Of all 360 articles included in this review, nearly two-thirds adopted quantitative research methods, among which structural equation model is the most preferred analysis method. We speculate that it is because the latent variables involved in psychology research cannot be accurately and directly measured, and structural equation model can make up for the shortcomings of limited applicability of traditional analysis methods. Regression-based methods are also widely used to analyze various quantitative data. There are still quite a few studies using qualitative research methods, and the text analysis method that includes topic analysis, content analysis, topic modeling etc. is the first choice. Although mixed method only accounts for a small proportion, it has gradually become a trend as it can maximize the achievement of research objectives by combining the advantages of qualitative and quantitative methods.

### FUTURE RESEARCH

Based on an overview of current literatures, we identify several gaps in existing research and an agenda for future research. First, for the demand and supply sides participants of P2P accommodation ecosystem, research on consumer social interactions in the service encounter stage is relatively under-investigated and limited to the host-guest relationship. Future research could extend to how the interaction between consumers and different actors individually affects the consumer accommodation experience and how they work together. As for hosts, the current research deficit mainly centered on the ignorance of hosts' sharing experience. Future research should focus on this topic and how this elicits other attitudinal and behavioral responses such as satisfaction. Second, in regard to the platform, it is suggested that platform-oriented research should be broadened in the future through two paths: one being the downward management of platform users, and the other being the upward management of the enterprise's image. As intermediaries, platforms are responsible for facilitating, protecting, and regulating transactions. Future research could further explore how they optimize host-customer matching, eliminate discrimination, and reduce users' perceived privacy, security, and other risks. Third, research on the development of regulatory policies for P2P accommodation, or an examination of their effects, should consider timeliness and regionality. We recommend using mixed methods in the future to investigate specific regulation in a particular region and to expand the study of impact effects to social sectors such as public health and environmental protection. For community residents, Subsequent research should surpass current limitations of investigating only passive attitudinal or behavioral responses and stress the proactivity of community residents in influencing P2P accommodation activities. Finally, leaving aside the limitation of focusing on one subject, future scholars should also advance the depth of psychology and behavior research in P2P accommodation from a cross-subject and multi-subject perspective. One possibility is to expand research perspectives to explore multiple psychological and behavioral paradigms, especially on the propositions of trust establishment, interaction, experience construction, and value creation.

### ACKNOWLEDGMENT

This work is supported by the National Social Science Foundation of China (Grant No. 19BGL258).

### REFERENCES

- Belarmino, A., & Koh, Y. (2022). When the party's over: what influences event peer-to-peer accommodation owners to re-enter the market? *Current Issues in Tourism*, 25(21), 3518-3533. <https://doi.org/10.1080/13683500.2020.1826412>
- Belk, R. (2007). Why not share rather than own? *The Annals of the American Academy of Political and Social Science*, 611(1), 126-140. <https://doi.org/10.1177/0002716206298483>
- Bridges, J., & Vasquez, C. (2018). If nearly all Airbnb reviews are positive, does that make them meaningless? *Current Issues in Tourism*, 21(18), 2065-2083. <https://doi.org/10.1080/13683500.2016.1267113>
- Calabro, A., Nisar, T. M., Torchia, M., & Tseng, H. T. (2022). Establishing trust in the sharing economy: an analysis of organizational, systems and interpersonal level trust. *Information Technology & People*. <https://doi.org/10.1108/ITP-04-2022-0313>
- Carroll, G., & Kovacs, B. (2018). Commentary on authenticity and the sharing economy. *Academy of Management Discoveries*, 4(3), 371-372. <https://doi.org/10.5465/amd.2018.0016>
- Casamatta, G., Giannoni, S., Brunstein, D., & Jouve, J. (2022). Host type and pricing on Airbnb: Seasonality and perceived market power. *Tourism Management*, 88, 104433. <https://doi.org/10.1016/j.tourman.2021.104433>
- Chen, Y. Y., Huang, Y. X., & Tan, C. H. (2021). Short-term rental and its regulations on the home-sharing platform. *Information & Management*, 58(3), 103322. <https://doi.org/10.1016/j.im.2020.103322>
- Cho, S., Park, C., & Kim, J. (2017). Leveraging Consumption Intention with Identity Information on Sharing Economy Platforms. *Journal of Computer Information Systems*, 59(2), 178-187. <https://doi.org/10.1080/08874417.2017.1326295>
- Chuah, S. H.-W., Rasoolimanesh, S. M., Aw, E. C.-X., & Tseng, M.-L. (2022). Lord, please save me from my sins! Can CSR mitigate the negative impacts of sharing economy on consumer trust and corporate reputation? *Tourism Management Perspectives*, 41, 100938. <https://doi.org/10.1016/j.tmp.2022.100938>
- Chung, J., Johar, G. V., Li, Y., Netzer, O., & Pearson, M. (2022). Mining Consumer Minds: Downstream Consequences of Host Motivations for Home-Sharing Platforms. *Journal of Consumer Research*, 48(5), 817-838. <https://doi.org/10.1093/jcr/ucab034>
- Chung, J. Y. (2017). Online friendships in a hospitality exchange network: a sharing economy perspective. *International Journal of Hospitality Management*, 29(12), 3177-3190. <https://doi.org/10.1108/IJCHM-08-2016-0475>



- Chung, Y., & Sarnikar, S. (2022). Understanding host marketing strategies on Airbnb and their impact on listing performance: a text analytics approach. *Information Technology & People*, 35(7), 2075-2097. <https://doi.org/10.1108/ITP-10-2020-0718>
- Cui, R. M., Li, J., & Zhang, D. J. (2020). Reducing Discrimination with Reviews in the Sharing Economy: Evidence from Field Experiments on Airbnb. *Management Science*, 66(3), 1071-1094. <https://doi.org/10.1287/mnsc.2018.3273>
- Dolnicar, S. (2019). A review of research into paid online peer-to-peer accommodation Launching the Annals of Tourism Research curated collection on peer-to-peer accommodation. *Annals of Tourism Research*, 75, 248-264. <https://doi.org/10.1016/j.annals.2019.02.003>
- Falk, M. T., & Yang, Y. (2021). Hotels benefit from stricter regulations on short-term rentals in European cities. *Tourism Economics*, 27(7), 1526-1539. <https://doi.org/10.1177/1354816620918769>
- Farmaki, A., Stergiou, D., & Kaniadakis, A. (2022). Self-perceptions of Airbnb hosts' responsibility: a moral identity perspective. *Journal of Sustainable Tourism*, 30(5), 983-1003. <https://doi.org/10.1080/09669582.2019.1707216>
- Farmaki, A., & Stergiou, D. P. (2019). Escaping loneliness Through Airbnb host-guest interactions. *Tourism Management*, 74, 331-333. <https://doi.org/10.1016/j.tourman.2019.04.006>
- Fradkin, A., Grewal, E., & Holtz, D. (2021). Reciprocity and Unveiling in Two-Sided Reputation Systems: Evidence from an Experiment on Airbnb. *Marketing Science*, 40(6), 1013-1029. <https://doi.org/10.1287/mksc.2021.1311>
- Furukawa, N., & Onuki, M. (2022). The design and effects of short-term rental regulation. *Current Issues in Tourism*, 25(20), 3245-3260. <https://doi.org/10.1080/13683500.2019.1638892>
- Ganapati, S., & Reddick, C. G. (2018). Prospects and challenges of sharing economy for the public sector. *Government Information Quarterly*, 35(1), 77-87. <https://doi.org/10.1016/j.giq.2018.01.001>
- Gerwe, O., Silva, R., & de Castro, J. (2022). Entry of Providers Onto a Sharing Economy Platform: Macro-Level Factors and Social Interaction. *Entrepreneurship Theory and Practice*, 46(4), 833-856. <https://doi.org/10.1177/1042258720903404>
- Grimmer, L., Vorobjovas-Pinta, O., & Massey, M. (2019). Regulating, then deregulating Airbnb: The unique case of Tasmania (Australia). *Annals of Tourism Research*, 75, 304-307. <https://doi.org/10.1016/j.annals.2019.01.012>
- Guttentag, D., Smith, S., Potwarka, L., & Havitz, M. (2018). Why Tourists Choose Airbnb: A Motivation-Based Segmentation Study. *Journal of Travel Research*, 57(3), 342-359. <https://doi.org/10.1177/0047287517696980>
- Han, W. C., Wang, X. Y., Ahsen, M. E., & Wattal, S. (2021). The Societal Impact of Sharing Economy Platform Self-Regulations-An Empirical Investigation. *Information Systems Research*, 33(4), 1303-1323. <https://doi.org/10.1287/isre.2021.1044>
- Jordan, E. J., & Moore, J. (2018). An in-depth exploration of residents' perceived impacts of transient vacation rentals. *Journal of Travel & Tourism Marketing*, 35(1), 90-101. <https://doi.org/10.1080/10548408.2017.1315844>
- Kabadayi, E. T., Aksoy, N. C., Yazici, N., & Alan, A. K. (2022). Airbnb as a sharing economy-enabled digital service platform: The power of motivational factors and the moderating role of experience. *Tourism Economics*, 28(3), 748-771. <https://doi.org/10.1177/13548166211044606>
- Klarin, A., & Suseno, Y. (2021). A state-of-the-art review of the sharing economy: Scientometric mapping of the scholarship. *Journal of Business Research*, 126, 250-262. <https://doi.org/10.1016/j.jbusres.2020.12.063>
- Koh, Y., Belarmino, A., & Kim, M. G. (2020). Good fences make good revenue: An examination of revenue management practices at peer-to-peer accommodations. *Tourism Economics*, 26(7), 1108-1128. <https://doi.org/10.1177/1354816619867579>
- Li, Y. Q., Peng, L. X., Ma, S., & Zhou, X. M. (2022). Beauty premium or beauty penalty in sharing accommodation situations based on lay theories. *International Journal of Hospitality Management*, 34(3), 929-950. <https://doi.org/10.1108/IJCHM-03-2021-0300>
- Liang, S., Zhang, X. X., Li, C. X., Li, H., & Yu, X. Y. (2021). Tit for tat: understanding the responding behavior of property hosts on peer-to-peer rental platforms. *International Journal of Hospitality Management*, 33(3), 1105-1126. <https://doi.org/10.1108/IJCHM-07-2020-0705>
- Liu, F. Z., Lai, K. H., Wu, J., & Luo, X. (2022). How Electronic Word of Mouth Matters in Peer-to-Peer Accommodation: The Role of Price and Responsiveness. *International Journal of Electronic Commerce*, 26(2), 174-199. <https://doi.org/10.1080/10864415.2022.2050581>
- Lu, L., Mody, M., & Andajigarmaroudi, S. (2020). Exploring guest response towards service failure in home-sharing: service presence and consumption motivation. *International Journal of Hospitality Management*, 87, 102498. <https://doi.org/10.1016/j.ijhm.2020.102498>
- Luo, P., Ma, X. M., Zhang, X. F., Liu, J. W., & He, H. W. (2021). How to make money with credit information? Information processing on online accommodation-sharing platforms. *Tourism Management*, 87, 104384. <https://doi.org/10.1016/j.tourman.2021.104384>
- Luo, Y., & Tang, R. (2019). Understanding hidden dimensions in textual reviews on Airbnb: An application of modified latent aspect rating analysis (LARA). *International Journal of Hospitality Management*, 80, 144-154. <https://doi.org/10.1016/j.ijhm.2019.02.008>
- Ma, S., Cui, X. B., Xiao, X. H., & Zhao, X. N. (2022). The impact of photo verification service on sales performance in the peer-to-peer economy: Moderating role of customer uncertainty. *Journal of Business Research*, 142, 45-55. <https://doi.org/10.1016/j.jbusres.2021.12.021>
- Mahadevan, R. (2019). To be or not to be a host in the peer-to-peer accommodation sector. *International Journal of Hospitality Management*, 81, 159-168. <https://doi.org/10.1016/j.ijhm.2018.12.007>

- Marth, S., Hartl, B., & Penz, E. (2022). Sharing on platforms: Reducing perceived risk for peer-to-peer platform consumers through trust-building and regulation. *Journal of Consumer Behavior*, 21(6), 1255-1267. <https://doi.org/10.1002/cb.2075>
- Mody, M., Suess, C., & Dogru, T. (2019). Not in my backyard? Is the anti-Airbnb discourse truly warranted? *Annals of Tourism Research*, 74, 198-203. <https://doi.org/10.1016/j.annals.2018.05.004>
- Mody, M., Suess, C., & Dogru, T. (2021). Does Airbnb impact non-hosting Residents' quality of life? Comparing media discourse with empirical evidence. *Tourism Management Perspectives*, 39, 100853. <https://doi.org/10.1016/j.tmp.2021.100853>
- Moher, D., Liberati, A., Tetzlaff, J., Altman, D. G., & Group, P. (2009). Preferred reporting items for systematic reviews and meta-analyses: the PRISMA statement. *International journal of surgery*, 8(5), 336-341. <https://doi.org/10.1016/j.ijsu.2010.02.007>
- Moon, H., Miao, L., Hanks, L., & Line, N. D. (2019). Peer-to-peer interactions: Perspectives of Airbnb guests and hosts. *International Journal of Hospitality Management*, 77, 405-414. <https://doi.org/10.1016/j.ijhm.2018.08.004>
- Mousavi, R., & Kexin, Z. (2022). Examining the Impacts of Airbnb's Review Policy Change on Listing Reviews. *Journal of the Association for Information Systems*, 23(1), 303-328. <https://doi.org/10.17705/1jais.00720>
- Muschter, S., Caldicott, R. W., von der Heide, T., & Che, D. (2022). Third-party impacts of short-term rental accommodation: a community survey to inform government responses. *Journal of Sustainable Tourism*, 30(5), 1102-1121. <https://doi.org/10.1080/09669582.2020.1860067>
- Nieuwland, S., & van Melik, R. (2020). Regulating Airbnb: how cities deal with perceived negative externalities of short-term rentals. *Current Issues in Tourism*, 23(7), 811-825. <https://doi.org/10.1080/13683500.2018.1504899>
- Parente, R. C., Geleilate, J.-M. G., & Rong, K. (2018). The Sharing Economy Globalization Phenomenon: A Research Agenda. *Journal of International Management*, 24(1), 52-64. <https://doi.org/10.1016/j.intman.2017.10.001>
- Park, S. K., Kwak, K. T., & Lee, B. G. (2019). Policy compliance and deterrence mechanism in the sharing economy Accommodation sharing in Korea. *Internet Research*, 29(5), 1124-1148. <https://doi.org/10.1108/INTR-03-2018-0098>
- Paulauskaite, D., Powell, R., Coca-Stefaniak, J. A., & Morrison, A. M. (2017). Living like a local: Authentic tourism experiences and the sharing economy. *International Journal of Tourism Research*, 19(6), 619-628. <https://doi.org/10.1002/jtr.2134>
- Peng, L. F., Wang, J. W., Huang, Y. H., & Wang, X. R. (2022). Self-construal, moral disengagement, and unethical behavior in peer-to-peer accommodation: the moderating role of perceived consumption liquidity. *Journal of Sustainable Tourism*, 31(6), 1336-1355. <https://doi.org/10.1080/09669582.2022.2043876>
- Pera, R., Viglia, G., & Furlan, R. (2016). Who Am I? How Compelling Self-storytelling Builds Digital Personal Reputation. *Journal of Interactive Marketing*, 35, 44-55. <https://doi.org/10.1016/j.intmar.2015.11.002>
- Priporas, C. V., Stylos, N., Vedanthachari, L. N., & Santiwatana, P. (2017). Service quality, satisfaction, and customer loyalty in Airbnb accommodation in Thailand. *International Journal of Tourism Research*, 19(6), 693-704. <https://doi.org/10.1002/jtr.2141>
- Qiu, H. Q., Chen, D. Z., Bi, J. W., Lyu, J. Y., & Li, Q. H. (2022). The construction of the affinity-seeking strategies of Airbnb homestay hosts. *International Journal of Hospitality Management*, 34(3), 861-884. <https://doi.org/10.1108/IJCHM-10-2020-1157>
- Sainaghi, R. (2020). The current state of academic research into peer-to-peer accommodation platforms. *International Journal of Hospitality Management*, 89, 102555. <https://doi.org/10.1016/j.ijhm.2020.102555>
- Scerri, M. A., & Presbury, R. (2020). Airbnb Superhosts' talk in commercial homes. *Annals of Tourism Research*, 80, 102827. <https://doi.org/10.1016/j.annals.2019.102827>
- Shi, S., Gursoy, D., & Chen, L. (2019). Conceptualizing home-sharing lodging experience and its impact on destination image perception: A mixed method approach. *Tourism Management*, 75, 245-256. <https://doi.org/10.1016/j.tourman.2019.05.012>
- Shin, H. W., Fan, A., & Lehto, X. (2021). Peer-to-peer accommodation: A meta-analysis of factors affecting customer satisfaction and loyalty. *International Journal of Tourism Research*, 23(4), 581-596. <https://doi.org/10.1002/jtr.2428>
- So, K. K. F., Oh, H., & Min, S. (2018). Motivations and constraints of Airbnb consumers: Findings from a mixed-methods approach. *Tourism Management*, 67, 224-236. <https://doi.org/10.1016/j.tourman.2018.01.009>
- Stergiou, D. P., & Farmaki, A. (2020). Resident perceptions of the impacts of P2P accommodation: Implications for neighbourhoods. *International Journal of Hospitality Management*, 91, 102411. <https://doi.org/10.1016/j.ijhm.2019.102411>
- Sthapit, E., & Jimenez-Barreto, J. (2018). Exploring tourists' memorable hospitality experiences: An Airbnb perspective. *Tourism Management Perspectives*, 28, 83-92. <https://doi.org/10.1016/j.tmp.2018.08.006>
- Stienmetz, J. L., Liu, A. Y., & Tussyadiah, I. P. (2022). Impact of perceived peer to peer accommodation development on community residents' well-being. *Current Issues in Tourism*, 25(21), 3481-3499. <https://doi.org/10.1080/13683500.2020.1797644>
- Suess, C., Kang, S., Dogru, T., & Mody, M. (2020). Understanding the influence of "feeling at home" on healthcare travelers' well-being: a comparison of Airbnb and hotel homescapes. *Journal of Travel & Tourism Marketing*, 37(4), 479-494. <https://doi.org/10.1080/10548408.2020.1759481>
- Suess, C., Woosnam, K. M., & Erul, E. (2020). Stranger-danger? Understanding the moderating effects of children in the household on non-hosting residents' emotional solidarity with Airbnb visitors, feeling safe, and support for Airbnb. *Tourism Management*, 77, 103952. <https://doi.org/10.1016/j.tourman.2019.103952>
- Tamilmani, K., Rana, N. P., Nunkoo, R., Raghavan, V., & Dwivedi, Y. K. (2022). Indian Travellers' Adoption of Airbnb Platform. *Information Systems Frontiers*, 24(1), 77-96. <https://doi.org/10.1007/s10796-020-10060-1>

- Teubner, T., & Flath, C. M. (2019). Privacy in the Sharing Economy. *Journal of the Association for Information Systems*, 20(3), 213-242. <https://doi.org/10.17705/1jais.00534>
- Tsiotsou, R. H., & Wirtz, J. (2015). 'The three-stage model of service consumption', In Bryson, J. R. & Daniels, P. W. (Eds.), *Handbook of service business* (pp. 105-128). Cheltenham: Edward Elgar.
- Tussyadiah, S. P., & Park, S. (2018). When guests trust hosts for their words: Host description and trust in sharing economy. *Tourism Management*, 67, 261-272. <https://doi.org/10.1016/j.tourman.2018.02.002>
- Vila-Lopez, N., & Kuster-Boluda, I. (2022). Sharing-collaborative economy in tourism: A bibliometric analysis and perspectives for the post-pandemic era. *Tourism Economics*, 28(1), 272-288. <https://doi.org/10.1177/13548166211035712>
- Vinogradov, E., Leick, B., & Kivedal, B. K. (2020). An agent-based modelling approach to housing market regulations and Airbnb-induced tourism. *Tourism Management*, 77, 104004. <https://doi.org/10.1016/j.tourman.2019.104004>
- Wang, C. H., & Jeong, M. (2018). What makes you choose Airbnb again? An examination of users' perceptions toward the website and their stay. *International Journal of Hospitality Management*, 74, 162-170. <https://doi.org/10.1016/j.ijhm.2018.04.006>
- Wang, W. F., Su, C. C., Chan, J. H., & Qi, X. G. (2020). Operational risks and coping strategies of micro-enterprise in peer-to-peer accommodation service sector: evidences from China. *Industrial Management & Data Systems*, 120(9), 1759-1775. <https://doi.org/10.1108/IMDS-04-2020-0238>
- Wang, Y. C., Asaad, Y., & Filieri, R. (2020). What Makes Hosts Trust Airbnb? Antecedents of Hosts' Trust toward Airbnb and Its Impact on Continuance Intention. *Journal of Travel Research*, 59(4), 686-703. <https://doi.org/10.1177/0047287519855135>
- Xie, K. L., & Kwok, L. (2017). The effects of Airbnb's price positioning on hotel performance. *International Journal of Hospitality Management*, 67, 174-184. <https://doi.org/10.1016/j.ijhm.2017.08.011>
- Xie, K. R., & Mao, Z. X. (2019). Locational Strategy of Professional Hosts: Effect on Perceived Quality and Revenue Performance of Airbnb Listings. *Journal of Hospitality & Tourism Research*, 43(6), 919-929. <https://doi.org/10.1177/1096348019836277>
- Xu, F., La, L., Zhen, F., Lobsang, T., & Huang, C. (2019). A data-driven approach to guest experiences and satisfaction in sharing. *Journal of Travel & Tourism Marketing*, 36(4), 484-496. <https://doi.org/10.1080/10548408.2019.1570420>
- Xu, Y., Hazée, S., So, K. K. F., Li, K. D., & Malthouse, E. C. (2021). An evolutionary perspective on the dynamics of service platform ecosystems for the sharing economy. *Journal of Business Research*, 135, 127-136. <https://doi.org/10.1016/j.jbusres.2021.05.056>
- Xue, L., Leung, X. Y., & Ma, S. H. (2022). What makes a good "guest": Evidence from Airbnb hosts' reviews. *Annals of Tourism Research*, 95, 103426. <https://doi.org/10.1016/j.annals.2022.103426>
- Ye, S., Chen, S. Y., & Paek, S. (2022). Moderating Effect of Trust on Customer Return Intention Formation in Peer-to-Peer Sharing Accommodation. *Journal of Hospitality & Tourism Research*, 47(2), 328-353. <https://doi.org/10.1177/10963480211014249>
- Yeon, J., Kim, S., Song, K., & Kim, J. (2022). Examining the impact of short-term rental regulation on peer-to-peer accommodation performance: a difference-in-differences approach. *Current Issues in Tourism*, 25(19), 3212-3224. <https://doi.org/10.1080/13683500.2020.1814704>
- Zhang, G. J., Wang, R., & Cheng, M. M. (2020). Peer-to-peer accommodation experience: A Chinese cultural perspective. *Tourism Management Perspectives*, 33, 100621. <https://doi.org/10.1016/j.tmp.2019.100621>
- Zhu, L., Lin, Y., & Cheng, M. M. (2020). Sentiment and guest satisfaction with peer-to-peer accommodation: When are online ratings more trustworthy? *International Journal of Hospitality Management*, 86, 102369. <https://doi.org/10.1016/j.ijhm.2019.102369>



## Stock Market or Real Estate Market: Who is the Leader?

Yao Chun Tsao<sup>1,\*</sup>  
Shun-Jen Hsueh<sup>2</sup>

\*Corresponding author

<sup>1</sup> Assistant Professor, Cheng Shiu University, Kaohsiung, Taiwan, k0486@gcloud.csu.edu.tw

<sup>2</sup> Associate Professor, Cheng Shiu University, Kaohsiung, Taiwan, k0442@gcloud.csu.edu.tw

### ABSTRACT

We apply data from five OECD countries during the period 1980/Q1 – 2010/Q2 to examine the causal relationship between the stock market and real estate market by using quantile regression causality analysis. The wealth effect is more significant in almost all the quantile intervals, especially in Canada and Japan. Surprisingly, in the tail quantile interval, we can often find that these two markets have a significant two-way causal relationship. The existence of significant tail interdependence implies that investors are unable to hedge the risk across the real estate and stock markets in extreme volatility.

*Keywords:* wealth effect, stock market, real estate market, quantile regression causality analysis.

### INTRODUCTION

There are two main mechanisms for studying the causal relationship between the stock market and the real estate market. The first mechanism is the wealth effect. This effect indicates that when the stock market rises, investors' wealth will increase unexpectedly. This increase will drive up their demand for real estate, so the stock market will lead the real estate market. The second mechanism is the credit-price effect. This effect emphasizes that real estate is always used as collateral for corporate borrowing. When the price of real estate increases, it can improve the company's balance sheet and reduce the company's borrowing costs. The movement will make the company do more investments and will push up the company's stock price. For this reason, the effect of credit prices will cause the real estate market to lead the stock market. Many researchers have confirmed the wealth effects between the stock market and the real estate market (Kapopoulos and Siokis, 2005; Sutton, 2002; Kakes and Van Den End, 2004; Ibrahim, 2010). On the other hand, Sim and Chang (2006) found that the relationship between the two markets was the credit price effect, and Lean and Smyth (2012), Liu and Su (2010), and Su (2011) confirmed that the two effects existed simultaneously. Overall, most empirical studies support the wealth effect. Traditionally, they use causality methods to prove the mutual effects in the mean values. We believe that the causal relationship between these two variables under different quantiles may have different impacts. To depict a more complete analysis of this issue, we use the quantile causality test, with a view to making up for the theoretical research gap in this area and putting forward practical implications for governments and investors.

There is some research about the causal relationship between the stock market and the real estate market-operated econometric models such as Granger causality, Vector Autoregressive model (VAR), and co-integration. Gyourko and Keim (1992) used REIT returns as dependent variables and S & P500 returns as independent variables, proving that the stock market will contain important and time-dependent factors to affect the real estate market. Okunev et al. (2000) adopted US real estate and S & P500 stock market data and pointed out different effects between the two markets by different causality tests. They advocated linear causality to conclude that the real estate market will affect the stock market in one direction, with the non-linear causality test. They also found that the stock market will affect the real estate market in one direction. Jud and Winkler (2002) showed that house prices are significantly led by rising stock markets, population, income, and interest rates, showing a significant real wealth effect. Kapopoulos and Siokis (2005) used a single-equation framework to make a Granger causality test. The former used data from the San Francisco area to confirm that stock prices were ahead of real estate prices and that the wealth effect was valid. Similarly, the latter used data from Greek cities to detect the wealth effect hypothesis in Athens was valid, but not true for other towns. Liu and Su (2010) compared China's stock index and real estate index to test the relationship and found that these two markets existed a two-way causal relationship. That is, there exists both wealth effect and credit price effect in China. Su (2011) used data from eight Western European countries to test the Granger causality of the stock market and housing market. The results clearly show that the credit price effect exists in Germany, the Netherlands, and the United Kingdom, and the wealth effect also existed in Belgium and Italy. Both effects existed at the same time.

Sutton (2002) cited data from six developed countries (United States, United Kingdom, Canada, Ireland, New Zealand, and Australia) to prove that changes in house prices can be guided by national income, interest rates, and stock prices, which also

provides obvious evidence of wealth effect. Seo and Kim (2000) and Park and Park (2001) conducted related research on South Korea, using the VAR model and quarterly data for different periods, and demonstrated stock price is leading the overall economic variables such as land prices, GDP growth rates, and interest rates. Shon et al. (2003) compiled the quarterly data from 1986Q1 to 2001Q4 in South Korea and deduced that the housing market price was ahead of the stock market, but not the same in the opposite direction. Chi (1998) used the Geweke-Meese-Dent homogeneity test to show that the real estate market is about six months behind the bond market and about two years behind the stock market. Kakes and Van Den End (2004) used the VAR model to test the Dutch market and used real disposable income and 10-year government bond yields as control variables. They advocated that stock prices and interest rates have explanatory evidence on house price changes. The study also showed that the Dutch market does not have a credit price effect. Sim and Chang (2006) took the GDP growth rate and 3-year corporate bond yield rate as control variables to test the Korean market. The results disclosed house prices and land prices Granger caused stock prices, but the opposite is not the same. The study showed credit price effect is especially established in the industrial land market.

Ibrahim (2010) used co-integration to test the relationship between Thai stock prices and real estate prices. The variables included real output and consumer price information, and the results showed a significant wealth effect. Lean and Smyth (2012) used individual REIT data instead of the REIT index as analysis variables, and interbank deposit interest rates as control variables, and found that some REITs have wealth effect, and for most other REITs, the real estate market and stock market will have mutual feedback effect. Yuksel (2016) used the global financial crisis in 2008 as a dividing point to examine the changes in the Turkish market before and after the crisis. It adopted the threshold co-integration structure to inspect that the stock market and the real estate market existed both wealth and credit price effect before the 2008 financial crisis, but only credit price effect existed during the 2008 financial crisis.

From the above literature reviews, we found that the stock market has a significant lead in the real estate market, while some research supported the opposite direction, or the two markets have mutual feedback. In addition, we also found that the same country may produce different leading and lagging situations at different time intervals. In the past, the mutual influence of the two variables existed based on the overall mean values of the variables, but the interaction between the two variables with quantiles is rare (Ding, et al., 2014). Therefore, our research attempts to fill the theoretical gap from the perspective of quantile causality. In addition, in order to make the results more robust and effective and clearly understand the relationship between the stock market and real estate market performance, unlike previous papers which often used single-country data to illustrate the correlation between the two markets, this paper will use five OECD countries data, over 30 years, to explore its cause and effect more comprehensively. Finally, we will conduct an in-depth analysis of the results, and explain the policy implications of the results from the policy and practical perspectives.

## RESEARCH METHOD

### Data Description

For the Granger causality relationship between stock returns and house returns, we propose the following models:

$$Y = f(X) \quad (1)$$

Where Y is the house returns (code HPI in the table); X is the stock returns (code SP in the table). The stock price index of each country from Q1 1980 to Q2 2010 is drawn from DataStream, and the price index data is compiled from The Dallas Fed's International House Price Database. The data includes five OECD countries including the United States, Japan, Canada, Australia, and the United Kingdom. The statistics of the return series are reported in Tables 1 and Table 2. The means of the return series is close to zero, but the means of stock returns in all countries is higher than the average house returns. The high investment portfolio style of the stock market also reflects the investment preference in these countries. Compared with the housing returns, the stock returns in various countries appear a big extension of volatility, indicating that house prices in developed countries are stable. All return series show higher kurtosis, except for Japan's housing returns, and most countries have higher peak returns, indicating that future stock returns are more likely to occur at outliers' extreme values.

Table 1: Summary statistics for return series of house markets in five countries

	HPI_C	HPI_J	HPI_UK	HPI_USA	HPI_A
Mean	0.014483	0.000912	0.018274	0.009731	0.019817
Median	0.011488	-0.003330	0.018334	0.011251	0.015846
Maximum	0.126930	0.041888	0.114760	0.037962	0.099772

Minimum	-0.061830	-0.033520	-0.056000	-0.031720	-0.021900
Std. Dev.	0.028424	0.014843	0.023969	0.011082	0.022852
Skewness	0.820392	0.748971	0.148791	-1.217751	1.001473
Kurtosis	5.539115	3.333166	5.159529	6.147726	4.340168

Notes : The symbols (C, J and A) stand for Canada, Japan and Australia, respectively.

Table 2: Summary statistics for return series of stock markets in five countries

	SP_C	SP_J	SP_UK	SP_USA	SP_A
Mean	0.017824	0.008656	0.021289	0.021642	0.020542
Median	0.024909	0.013337	0.021298	0.021999	0.029594
Maximum	0.203947	0.217812	0.165079	0.202128	0.216749
Minimum	-0.283710	-0.298050	-0.218750	-0.303840	-0.386640
Std. Dev.	0.076689	0.086785	0.063673	0.065917	0.080703
Skewness	-0.874404	-0.123524	-0.922496	-1.184274	-1.165118
Kurtosis	5.260739	3.671557	5.080612	7.905250	7.793996

Notes : The symbols (C, J and A) stand for Canada, Japan and Australia, respectively.

### Linear Granger Causality Test

When a variable  $x$  does not Granger-cause another variable  $y$ , it suggests that

$$E(y_t | (Y, X)_{t-1}) = E(y_t | Y_{t-1}), \text{ as,} \quad (2)$$

Where  $(Y, X)_{t-1}$  denotes the information set generated by  $y_i$  and  $x_i$  at time  $t-1$ . To conduct the Granger causality test for our study, we estimate the following models:

$$y_t = \alpha_0 + \sum_{i=1}^p \alpha_i y_{t-i} + \sum_{i=1}^q \beta_i x_{t-i} + \varepsilon_{y,t} \quad (3)$$

$$x_t = \varphi_0 + \sum_{i=1}^p \varphi_i x_{t-i} + \sum_{i=1}^q \phi_i y_{t-i} + \mu_{x,t} \quad (4)$$

Where  $X_t$  and  $Y_t$  respectively denote the housing returns and stock returns at time  $t$ , and  $\varepsilon_{y,t}$  and  $\mu_{x,t}$  are i.i.d. random disturbances.

We assess the null hypothesis that  $\beta_i=0$  for  $i$  mean  $1, 2, \dots, q$  in the above regression model(2). Rejecting the null hypothesis implies that the lagged values of  $x_t$  affect  $y_t$  and a causal relationship exists from  $x_t$  to  $y_t$ . Table 3 shows the linear Granger causality results in a mean of stock returns and housing returns. The results show that Australia, Japan, and the United Kingdom exist a one-way causality from stock returns to housing returns. The United States has a one-way causality from housing returns to stock returns. And Canada has two-way causality.

### Quantile Causality Test

Consider the following Granger non-causality test in quantiles:

$$Q_{y_t}(\tau | (Y, X)_{t-1}) = Q_{y_t}(\tau | y_{t-1}), \forall \tau \in [a, b]_{\text{a.s.}}, \quad (5)$$

Where  $Q_{y_t}(\tau | F)$  denotes the  $\tau$ th quantile of the distribution. If (5) holds, then  $x_t$  does not Granger-cause  $y_t$  over the quantile interval  $[a, b]$ . One can perform the Granger non-causality test in quantiles using the quantile regression method in Koenker and Bassett(1978). To test for the nonlinear causal relationship from the housing returns to stock returns, we consider the following conditional quantile function model:

$$Q_{y_t}(\tau | X_{t-1}) = a(\tau) + \sum_{j=1}^p \alpha_j(\tau) y_{t-j} + \sum_{j=1}^q \beta_j(\tau) x_{t-j} \quad (6)$$

The null hypothesis of non-causality in quantiles is.

$$H_0: \beta(\tau) = 0, \forall \tau \in [a, b],$$

Where  $\beta(\tau) = [\beta_1(\tau), \beta_2(\tau), \dots, \beta_q(\tau)]'$ . The Wald test is exercised. Koenker and Machado(1999) and Chuang et al.(2009) show that the sampling distribution of the Wald test statistic follows the sum of squares of  $p$  independent Bessel processes:

$$\sup W_T(\tau) \rightarrow \left\| \frac{B_q(\tau)}{\sqrt{\tau(1-\tau)}} \right\|^2 \quad (7)$$

Where  $W_T(\tau)$  denotes the Wald test statistic for the quantile  $\tau \in [a, b]$ ,  $B_q(\tau)$  is a vector of  $p$  independent Brownian bridges,  $B_p(\tau) = [\tau(1-\tau)]^{1/2} N(0, I_p)$  empirically, we can calculate the sup-Wald test statistic by

$$\sup W_T = \sup_{i=1,2,\dots,n} W_T(\tau_i).$$

The critical values of the sup-Wald test can be simulated with the standard Brownian motion using a Gaussian random walk with 3,000 i.i.d  $N(0, 1)$  innovations. Critical values of the test can be found in DeLong (1981) and Andrews (1993). To empirically perform the quantile causality test, we first select a lag order  $q^*$  for each quantile interval. We consider six quantile intervals: [0.05, 0.95], [0.05, 0.2], [0.2, 0.4], [0.4, 0.6], [0.6, 0.8], and [0.8, 0.95]. For example, if the null of  $\beta_q(\tau) = 0$  for  $\tau \in [0.05, 0.2]$  is not rejected under the lag- $q$  model, but the null  $\beta_{q-1}(\tau) = 0$  for  $\tau \in [0.05, 0.2]$  is rejected for the lag- ( $q - 1$ ) model, we infer that  $X_{t-q}$  does not Granger-cause  $Y_t$  in quantiles but  $X_{t-q+1}$  does.

We set the lag order as  $q^* = q - 1$  for the quantile interval [0.05, 0.2]. We conduct the sup-Wald test to evaluate the joint significance of all coefficients of lagged housing returns for six quantile intervals. From the sup-Wald statistic, we can conclude whether the housing returns lead the stock returns over the specific quantile interval. The simulated critical values of the sup-Wald test statistic allow us to check whether  $X$  Granger- cause  $Y$  over the specific quantile interval.

## RESULTS AND DISCUSSIONS

First, we use the Granger linear causality test to inspect the causal relationship between stock market returns and housing market returns in the five OECD countries. In Table 3, we argue that the stock market can impact the housing market (only the United States excluded, but its p-value is also close to a significant level of 10%), indicating that the wealth effect obviously existed; while the housing market affects the stock market only happened in the United States and Canada. It indicates that the credit price effect is not overall. In addition, Table 3 also shows most countries have a one-way dependence, and only Canada has a two-way dependence, indicating that the correlation between the stock market and the housing market varies for each country. The Granger linear causality test shown in Table 3 is based on the overall average trend of each country to see the relationship between the stock market and the housing market. Due to different national conditions, it seems to us to find a more consistent conclusion, so this paper uses the cause and effect of quantile regression. The analysis attempts to explain the causal relationship between the two markets from a more detailed perspective.

Table 3: Granger causality test: SP vs. HPI

Countries	Ho: SP does not cause HPI		Ho: HPI does not cause SP	
	p-value	Linear causality	p-value	Linear causality
USA	0.11383	No	0.06229*	Yes
UK	0.06256*	Yes	0.80304	No
Australia	0.02752**	Yes	0.58515	No
Canada	0.00665***	Yes	0.04236**	Yes
Japan	0.01884**	Yes	0.91244	No

Notes: Each interval in the square breaks is a quantile interval on which the null hypothesis holds.

\*, \*\* and \*\*\* denote significance at 10%, 5% and 1% levels, respectively.

Observe the quantile causality between the return of the US stock price index and the return of the house price index in Table 4. This table summarizes the lags and the sub-Wald test results of joint significance. From Table 4, we can find that when the price quantile of the housing returns is in the range [0.05, 0.2], the effect of stock returns on housing returns is significant, while the other quantile ranges are not significant. In the same way, we reverse the position of the dependent variable and the independent variable. We can also evaluate the quantile causality of the housing returns to the stock returns. It is clear that in

the quantile interval [0.05, 0.2] and [0.2, 0.4], house price compensation will significantly affect stock price compensation, and especially the former reaches a significant level of 1%. To observe the quantile causal relationship between the return of the UK stock price index and the return of the house price index in Table 5, we can tell that when the house price return quantile interval [0.8, 0.95], the effect of stock returns on housing returns is a significant level of 1%. The other quantile intervals are not significant. In the quantile causal relationship between the return of the house price index and the return of the stock price index, all quantile intervals are insignificant, indicating that the British housing market had no impact on the stock market during the study period.

Table 4: Quantile causality test: Stock prices vs. HPI in USA

Quantile interval	Ho: SP does not cause HPI		Ho: HPI does not cause SP	
	Lag periods	sup Wald test statistics	Lag periods	sup Wald test statistics
[0.05, 0.2]	2	32.77554***	4	60.95208***
[0.2, 0.4]	1	1.106901	1	7.487479**
[0.4, 0.6]	1	1.95691	1	1.620897
[0.6, 0.8]	1	0.867536	1	0.779125
[0.8, 0.95]	1	2.292681	1	2.166368
[0.05, 0.95]	2	31.45677***	3	31.40884***

Notes: Each interval in the square breaks is a quantile interval on which the null hypothesis holds.

\*, \*\* and \*\*\* denote significance at 10%, 5% and 1% levels, respectively.

Table 5: Quantile causality test: Stock prices vs. HPI in UK

Quantile interval	Ho: SP does not cause HPI		Ho: HPI does not cause SP	
	Lag periods	sup Wald test statistics	Lag periods	sup Wald test statistics
[0.05, 0.2]	1	4.156861	1	4.638297
[0.2, 0.4]	1	4.126135	1	0.170698
[0.4, 0.6]	1	3.107001	1	0.299151
[0.6, 0.8]	1	1.064746	1	0.53058
[0.8, 0.95]	3	24.36276***	1	0.397839
[0.05, 0.95]	1	4.129989	1	4.591303

Notes: Each interval in the square breaks is a quantile interval on which the null hypothesis holds.

\*, \*\* and \*\*\* denote significance at 10%, 5% and 1% levels, respectively.

Table 6, the quantile causal relationship between the Australian stock price index returns and the housing returns. When the house returns in the quantile intervals [0.05, 0.2] and [0.8, 0.95], the effect of stock returns on housing returns is significant. Especially the latter reached a significant level of 1%, and the other quantile intervals were not significant. In the quantile causal relationship between the house returns and stock returns, in the quantile interval [0.8, 0.95], the house price return will significantly affect the stock returns, and the other quantile intervals are not significant. The quantile causality between the Canadian stock returns and the house returns is shown in Table 7. All quantile intervals are significant, except for the quantile interval [0.4, 0.6], which shows that the German stock market is quite influential to the housing market. In the quantile causal relationship from the return of the house price index to the return of the stock price index, the statistics in the tail quantile intervals [0.05, 0.2] and [0.8, 0.95] demonstrate the house price return significantly affects the stock price return. Especially, it overwhelmingly rejects the null of non-causality at the 1% level in the top quantile interval [0.8, 0.95]. Besides, we find no evidence for the existence of a significant causal relationship between the house returns to the stock returns in the other quantile intervals.

Table 6: Quantile causality test: Stock prices vs. HPI in Australia

Quantile interval	Ho: SP does not cause HPI		Ho: HPI does not cause HPI	
	Lag periods	sup Wald test statistics	Lag periods	sup Wald test statistics
[0.05, 0.2]	2	10.82022**	1	2.326079
[0.2, 0.4]	1	1.209035	1	1.143041
[0.4, 0.6]	1	0.573052	1	0.34246
[0.6, 0.8]	1	1.032488	1	1.809567
[0.8, 0.95]	6	120.7832***	3	15.57004**
[0.05, 0.95]	6	120.7832***	1	2.326079

Notes: Each interval in the square breaks is a quantile interval on which the null hypothesis holds. \*, \*\* and \*\*\* denote significance at 10%, 5% and 1% levels, respectively.

Table 7: Quantile causality test: Stock prices vs. HPI in Canada

Quantile interval	Ho: SP does not cause HPI		Ho: HPI does not cause SP	
	Lag periods	sup Wald test statistics	Lag periods	sup Wald test statistics
[0.05, 0.2]	1	21.47887***	2	12.38777**
[0.2, 0.4]	1	5.673413*	1	0.389938
[0.4, 0.6]	1	3.327262	1	1.270773
[0.6, 0.8]	2	14.27981***	1	2.208827
[0.8, 0.95]	1	37.09723***	2	15.23833***
[0.05, 0.95]	1	37.09723***	2	14.75821**

Notes: Each interval in the square breaks is a quantile interval on which the null hypothesis holds.

\*, \*\* and \*\*\* denote significance at 10%, 5% and 1% levels, respectively.

Table 8 shows the quantile causality between the Japanese stock returns and the house returns. It discloses all the quantile intervals are significant, pointing out that the Japanese stock market has a considerable impact on the housing market. In the quantile causal relationship between the return of the house price index and the return of the stock price index, only in the quantile interval [0.8, 0.95], the house price return will affect the stock price return but only at a slightly significant level of 10%, and the other quantile intervals are not significant.

Table 8: Quantile causality test: Stock prices vs. HPI in Japan

Quantile interval	Ho: SP does not cause HPI		Ho: HPI does not cause SP	
	Lag periods	sup Wald test statistics	Lag periods	sup Wald test statistics
[0.05, 0.2]	1	19.37282***	1	0.771537
[0.2, 0.4]	1	13.16637***	1	0.89962
[0.4, 0.6]	1	9.58766**	1	0.526604
[0.6, 0.8]	1	5.67093*	1	0.277844
[0.8, 0.95]	1	11.45751***	1	6.315817*
[0.05, 0.95]	1	18.50812***	1	5.374582

Notes: Each interval in the square breaks is a quantile interval on which the null hypothesis holds.

\*, \*\* and \*\*\* denote significance at 10%, 5% and 1% levels, respectively.

## CONCLUSIONS

Although the interaction between the stock market and the housing market has been explored to some extent, there is still much controversy as to whether the causal relationship between these two markets exists as a wealth effect or a credit price effect. Our study applies quantile causality to conduct in-depth research on this issue. This is the first paper using the quantile regression causality model to test the nonlinear interaction between the stock market and the housing market in developed countries.

Table 9: Results of quantile causality test in 5 developed countries.

Quantile interval	Ho: SP does not cause HPI				
	USA	UK	Australia	Canada	Japan
[0.05, 0.2]	***		**	***	***
[0.2, 0.4]				*	***
[0.4, 0.6]					**
[0.6, 0.8]				***	*
[0.8, 0.95]		***	***	***	***
[0.05, 0.95]	***		***	***	***
Quantile interval	Ho: HPI does not cause SP				

	USA	UK	Australia	Canada	Japan
[0.05, 0.2]	***			**	
[0.2, 0.4]	**				
[0.4, 0.6]					
[0.6, 0.8]					
[0.8, 0.95]			**	***	*
[0.05, 0.95]	***			**	

Notes: Each interval in the square breaks is a quantile interval on which the null hypothesis holds.

\*, \*\* and \*\*\* denote significance at 10%, 5% and 1% levels, respectively

Overall, we summarize the results of the study in Table 9, where we can see that the wealth effect is more significant, that is, the stock returns will affect the return on house prices, especially in Canada and Japan, and it is in all the quantile intervals significantly. Surprisingly, in the tail quantile interval, we can often find that these two markets have a significant causal relationship, especially in the US and Canada exist a two-way causality in the lower tail quantile. Most importantly, Australia, Canada, and Japan have a two-way dependency but only in higher quantile intervals. The existence of significant tail interdependence implies that investors are unable to hedge the risk across the real estate and stock markets when they are extremely volatile. Therefore, when extreme returns exist, the financial authorities should pay more attention to these two markets for their increasing systemic risk.

## REFERENCES

- Andrews, D. (1993). Tests for parameter instability and structural change with unknown change point. *Econometrica*, 61, 821–856. <https://doi.org/10.2307/2951764>
- Chi, H. J. (1998). Circulative relation of stock, bond, real estate markets to business cycle. *Korean Management Review*, 25, 1277-1296.
- Chuang, C., Kuan, C., & Lin, H. (2009). Causality in quantiles and dynamic stock return volume relations. *Journal of Banking & Finance*, 33, 1351–1360. <https://doi.org/10.1016/j.jbankfin.2009.02.013>
- De Long, D. M. (1981). Crossing probabilities for a square root boundary by a Bessel process. *Communications in Statistics - Theory and Methods*, 10, 2197–2213. <https://doi.org/10.1080/03610928108828182>
- Ding, H., Chong, T. T., & Park, S. Y. (2014). Nonlinear dependence between stock and real estate markets in China. *Economics Letters*, 124, 526–529. <https://doi.org/10.1016/j.econlet.2014.05.035>
- Gyourko, J., & Keim, D. B. (1992). What does the stock market tell us about real estate returns? *Real Estate Economics*, 20(3), 457-485. <https://doi.org/10.1111/1540-6229.00591>
- Ibrahim, M. H. (2010). House price-stock price relations in Thailand: An empirical analysis. *International Journal of Housing Markets and Analysis*, 3, 69-82. <https://doi.org/10.1108/17538271011027096>
- Jud, D., & Winkler, D. (2002). The dynamics of metropolitan housing prices. *Journal of Real Estate Research*, 23, 29-45. <https://doi.org/10.1080/10835547.2002.12091069>
- Kakes, J., & Van Den End, J. W. (2004). Do stock prices affect house prices? Evidence for the Netherlands. *Applied Economics Letters*, 11, 741-744. <https://doi.org/10.1080/1350485042000254863>
- Kapopoulos, P., & Siokis, F. (2005). Stock and real estate prices in Greece: Wealth versus credit price effect. *Applied Economics Letters*, 12, 125-128. <https://doi.org/10.1080/1350485042000307107>
- Koenker, R., & Bassett, G. (1978). Regression quantiles. *Econometrica*, 46, 33–50.
- Koenker, R., & Machado, J. (1999). Goodness of fit and related inference processes for quantile regression. *Journal of the American Statistical Association*, 94, 1296–1310. <https://doi.org/10.2307/2669943>
- Lean, H., & Smyth, R. (2012). REITS, interest rates and stock prices in Malaysia. *International Journal of Business and Society*, 13, 49-62.
- Liu, Y., & Su, C. (2010). The relationship between the real estate and stock markets of China: Evidence from a nonlinear model. *Applied Financial Economics*, 20, 1741-1749. <https://doi.org/10.1080/09603107.2010.524616>
- Okunev, J., Wilson, P., & Zurbrugg, R. (2000). The causal relationship between real estate and stock markets. *Journal of Real Estate Finance and Economics*, 21, 251-261. <https://doi.org/10.1023/A:1012051719424>
- Park, H. J., & Park, C. (2001). A study on the forecasting in land market using time series model. *Housing Studies*, 9, 27-52.
- Seo, S. H., & Kim, K. S. (2000). An empirical study on the behavioral changes in real estate prices. *Housing Studies*, 8, 5-25.
- Shon, J. S., Kim, K. Y., & Kim, Y. S. (2003). A study on the forecasting model of the real estate market: The case of Korea. *Housing Studies*, 11, 49-74.
- Sim, S., & Chang, B. (2006). Stock and real estate markets in Korea: Wealth or credit-price effect. *Journal of Economic Research*, 11, 99-122.
- Su, C. (2011). Non-linear causality between the stock and real estate markets of Western European countries: Evidence from rank tests. *Economic Modelling*, 28, 845-851. <https://doi.org/10.1016/j.econmod.2010.10.021>
- Sutton, G. D. (2002). Explaining changes in house prices. *BIS Quarterly Review*, 46-55.



Yuksel, A. (2016). The relationship between stock and real estate prices in Turkey: Evidence around the global financial crisis. *Central Bank Review*, 16, 33-40. <https://doi.org/10.1016/j.cbrev.2016.03.006>

## Study of Short-Term Price Prediction with K-Line and SMA for Electrical Stocks in Taiwan

Po-Wen Chen <sup>1,\*</sup>  
Kuen-Liang Sue <sup>2</sup>  
Pei-Yin Yang <sup>3</sup>

\*Corresponding author

<sup>1</sup> National Central University, Taoyuan City, Taiwan, wilsonmau@gmail.com

<sup>2</sup> National Central University, Taoyuan City, Taiwan, klsue@mgt.ncu.edu.tw

<sup>3</sup> National Kaohsiung University of Science and Technology, Kaohsiung City, Taiwan, yangannabel@gmail.com

### ABSTRACT

In the past two decades, many studies in Taiwan devoted to investigate the impact of technical analysis on stock price predictions and on stock trading strategies. Most of these studies focused on the analysis of price indicators, and only a few on stock graphical analysis indicators. In addition, although quite a few studies also adopted combined signals (using two or more technical analysis indicators at the same time) as stock price prediction indicators, price indicators still play the most part in their research.

Our study will adopt the combined signal approach that center on K-line technical indicator (a type of stock graphical analysis), and supplemented by Simple Moving Average (SMA, a type of price indicator) to predict the rising and falling of stock price in the hope of helping investors find opportunities to gain more than 1.56% net profit within a month.

Our study collected and examined daily trading data of individual stocks from the Taiwan Stock Exchange (TWSE) ranging from 2012 to 2021 and targeted at the Electrical Industry (TWSE Stock Group No. 13) with a total of 420 stocks. The research results show that the combined signal approach composed of the key K-line and the Simple Moving Average (SMA) yields a higher return on investment than single signal approaches, and can be used to signal investors to enter the market creating true profit for themselves.

*Keywords:* K-line, Simple Moving Average, Combined Signal Approach, Stock Price Prediction, Technical Analysis

### INTRODUCTION

There have been many studies on stock operation strategies and performance, and the main technical analysis methods can be categorized into "graphical analysis indicators", "price indicators" and "volume indicators" (Yung-Chun Hsu, 2015). Our study analyzes Taiwan's research literature over the past two decades and finds that most of the analyses are based on the analysis of price indicators; in addition, although there have been a number of studies that use the combined signals (combined signals technical indicators composed of more than two trading rules) as stock price forecasting indicators, most of them are also based on the combined signals of the price indicators.

In view of the fact that there is not enough research on K-line for graphical technical indicators, this study has conducted combined K-line signal, which is a combination of K-line indicators and Simple Moving Averages (SMAs), for stock price prediction, our objective is to figure out the indicator that could help investor to build a short-term trading strategy and make effective profits by using combined K-line signal. The data source is the Taiwan stock market and the trading strategy is based on the percentage of stop-loss point and take-profit point, which is expected to serve as one of the bases for investors to buy and sell stocks on the signals.

### LITERATURE REVIEW

#### Candlestick chart

K-line is one of the technical analysis indicators generated by the opening price, high price, low price and closing price. The illustration is shown in Figure 1 below. On the left-hand side is the rising K-line, whose biggest feature is that the closing price is higher than the opening price, which means that the stock price is rising on that day; on the right-hand side is the falling K-line, whose biggest feature is that the opening price is higher than the closing price, which means that the stock price is falling on that day.

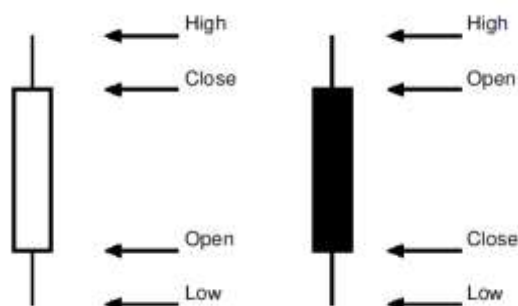

Source: G. CAGINAL P and H. LAURENT (1998).

Figure 1: Candlesticks representing one trading day.

Lv Tao, Yongtao Hao, Hao Yijie, and Shen Chunfeng (2017) explored the analysis of the predictive power of the K-line, pointing out that the technical analysis of the stock is mainly used to predict the future stock price by observing the stock price characteristics accumulated over a long period of time, and that the data of these technical analyses have two important characteristics: "The historical information will affect the future trend" and "History repeats itself", which shows that the relevant technical analyses can be used to predict the future trend of the stock price.

G. Caginalp and H. Laurent (1998) explored the K-line technical indicator as shown in Figure. 2, where the X-axis represents the time; and the Y-axis represents the stock price. When the stock price is in a downward trend, then the K-line signals of three consecutive days ( $t+1$ ,  $t+2$ ,  $t+3$ ) are used to determine whether the conditions of the three-day reversal patterns have been met.  $t+1$  represents the K-line of the first day of the Three-Day Reversal K-line,  $t+2$  represents the K-line of the second day, and  $t+3$  represents the K-line of the third day. The study states that "the three-day candlestick patterns has its predictive value".

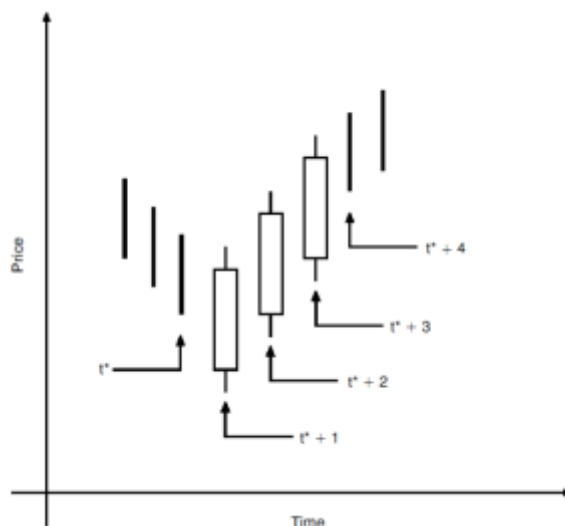

Source: Caginalp and Laurent (1998).

Figure 2: Three-day candlestick patterns.

Cong-Han Zheng (2020) used the "three-day reversal patterns" proposed by Caginalp and Laurent (1998) to investigate the return on investment of all listed stocks in the Taiwan stock market. Four upward three-day reversal and four downward three-day reversal K-line indicators were used, and Cong-Han Zheng (2020) concluded that "no significant positive profit was obtained from all graphical definitions (all the eight type of three-day reversal patterns)", most of the eight type of patterns are in negative profit.

Our study observed that the downtrend and uptrend definition Cong-Han Zheng (2020) used are 10-day Exponential Moving Average ( $EMA_{10}$ ) and 3-day Simple Moving Average ( $SMA_3$ ), while the holding strategies are 3-day and 10-day, and the sell-stock exit strategies are CL (Caginalp-Laurent) and MYR (Marshall-Young-Rose). CL (Caginalp-Laurent) was proposed by Caginalp and Laurent in 1998, which uses the average of the stock prices of three consecutive trading days after the expiration of the holding period as the transaction price of the simulated trade; MYR (Marshall-Young-Rose) proposed by Marshall et al. in 2006, uses the stock price of the previous trade on the closing day of the holding period as the transaction price.

There are four combinations of exit strategy and holding days as shown in Table 1 below. Taking No. 1 as an example, in the case of holding days at 3 and exit strategy at CL, when the union signal appears on  $t+3$ , the investor holds the stock from  $t+4$  to  $t+6$ , and after the expiration of the holding period, the average of the closing prices of the three days,  $t+7$ ,  $t+8$ , and  $t+9$ , will be used as the price to sell.

Table 1: Cong-Han Zheng (2020) Stock Holding and Exit Strategies.

No.	Number of days holding stock	Exit Strategy	Description
1	3	$R_{CL-3}$	Holding stocks from t+4 to t+6, after the expiration of the period, the average of the closing prices of t+7, t+8 and t+9 will be used as the exit price.
2	3	$R_{MYR-3}$	Holding shares from t+4 to t+6 and sell them before the close of trading on t+6.
3	10	$R_{CL-10}$	Holding the stock from t+4 to t+13, and after the expiration of the period, use the average of the closing prices of t+14, t+15 and t+16 to sell the stock.
4	10	$R_{MYR-10}$	Holding shares from t+4 to t+13 and sell them before the close of trading on t+13.

Source: This study.

The K-line indicators in our study also refer to the three-day reversal K-line indicator proposed by Caginalp and Laurent (1998). However, considering that the CL (Caginalp-Laurent) stock exit strategy could not be implemented in practice, and in view of Cong-Han Zheng (2020) conclusion that "no significant positive average return on investment was obtained regardless of any type of graphical definition", our study adjusts the parameters and the methodology and explained in detail in section of "RESEARCH METHODOLOGY".

### Moving Average

Moving average represents the average cost of ownership of an investment at the time. Take the 5-day average as an example, it means that if the closing price of the day is higher than the 5-day average, it means that those who entered the market in the past 5 days made a profit, and vice versa, it means that those who entered the market in the past 5 days made a loss.

There have been a number of studies that prove that technical analysis of moving averages can be profitable. For example, Hsiu-Yueh Wu (2013) pointed out that "when a golden cross of moving averages occur, a bullish wave is expected to take place"; Guan-Cheng Ke, Xiang-Ju Su, Xin-Suke Lin, and Hsiang-Hui Chu (2016) pointed out that "moving averages in technical analysis can be used to obtain significant positive investment performance". In addition, Tung-Chuan Wang (2018) demonstrated that stock operations based on moving averages outperformed the broader market. The findings of Hui-Chen Shen (2021) and Cheng-Yu Zhu (2021) also support that the use of moving averages as an investment strategy can be profitable.

In our study, the moving average technical indicator is used as one of the syndicated signal elements, we use Simple Moving Average (SMA) based on the same method as Taiwan stock exchange.

### Combined Signal Approach (CSA)

According to Camillo Lento (2009), the Combined Signal Approach (CSA) is a technical indicator of combined signals using two or more trading rules, and his study shows that "combined signals can help to increase profitability in situations where individual signals are not profitable".

Our study has also reviewed the domestic literature in Taiwan and found that in the domestic financial market, combined signals can also help to increase the return on investment. For example, Liang-Chun Li (2003), Tsung-Wen Hu (2010), En Wei (2012) and Chien-Sheng Chen (2020) demonstrated that the profitability of combined signals composed of different indicators is better than that of a single indicator. As for the combination of technical indicators for combined signals, Liang-Chun Li (2003) also pointed out that "more indicators in the combination won't bring additional profit", while Sheng-Yuan Mou (2013) and Yung-Chun Hsu (2015) also presented the same result, which showed that too many indicators could not enhance the performance, and that a combination of two or three indicators would be the best combination for profitability.

### Literature Summary

The review of the above literature and researches related to K-line signals, moving averages, and combined signals comes to the following conclusions:

1. K-line technical analysis and Moving average technical analysis are useful for stock price prediction, however, the conclusion of Cong-Han Zheng (2020) does not support the three-day reversal K-line technical indicator proposed by Caginalp and Laurent (1998). According to this conclusion, our study adjusts the relevant parameters before using the relevant K-line indicators.
2. Combined signals can help to increase profitability, however, two to three indicators are the most effective joint signal indicators, a combination with more indicators may not bring additional profit (Sheng-Yuan Mou, 2013).
3. To Improve the performance, in our study we leverage Combined Signal Approach (CSA) by including the Moving Average as part of the combined signal.

## RESEARCH METHODOLOGY

### Research Questions

To achieve the objective of our study - figure out the indicator that could help investor to build short-term trading strategy, we identify the following two research questions:

**RQ1.** Does buy stocks after the occurrence of a combined K-line signal yield a better return than a single signal?

Simulated trades will be used to verify the overall trend of the electronic stock market to answer this question.

**RQ2.** Can combined K-line signal be used as a hint of a short-term strategy for investors to enter the market and generate effective profits?

Our study use combined K-line signal to verify the profitability of electronics stocks in Taiwan to answer RQ2. "Short-term strategy" is identified as within 1 month trading according to the statement of "K-line information has a reference value for a period of 7 to 10 days" (Max Jönsson, 2016). And the baseline of profit we used to compare is one-month fixed deposit interest rate. "Effective profitability" is defined as a return greater than 1.56% based on the following two factors:

1. Positive return after deducting Taiwan stock transaction fees and taxes (totaling 0.585%).
2. The return on investment is higher than 0.975% (the one-month fixed deposit interest rate announced by Bank of Taiwan on March 18, 2023).

### Data Collection

Our study uses the daily trading data of Taiwan Stock Exchange (TWSE) individual stocks. The data scope includes the electronic stocks (TWSE stock group code 13) in the past ten years (2012 to 2021) as the experimental data, with a total of 420 stocks. The required information fields include opening price, high price, low price, closing price and price variance.

### Research Design

Our study adopts K-line and Simple Moving Average (SMA) to form the combined signals. It is hoped that the results of this analysis can be used to establish a short-term trading strategy for investors' reference. The design flow of this study is shown in Figure 3 below:

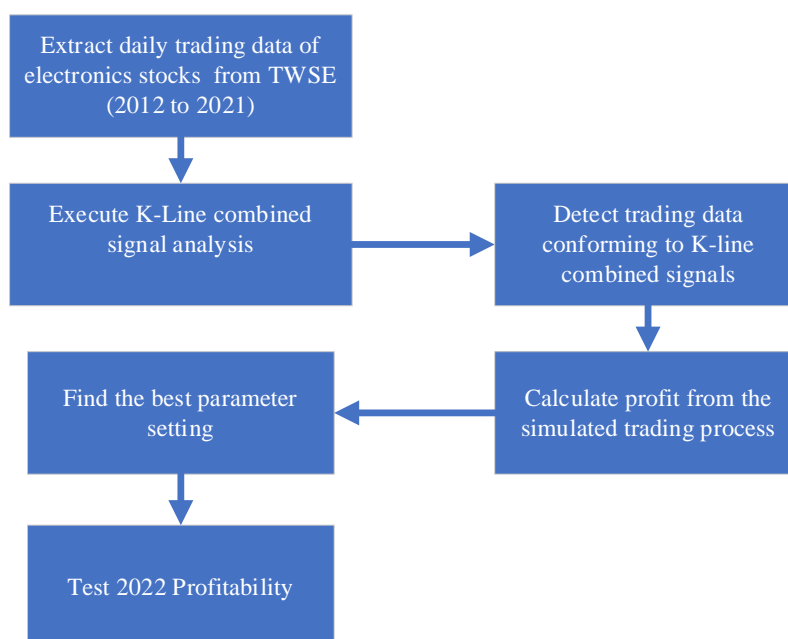

Source: This study

Figure 3: Research Flow

### Combined Signal Approach Analysis

With reference to the recommendations of the aforementioned scholars on Taiwan stocks, our study uses the intersection of the two technical indicators as shown in Figure 4 below as a basis for a buy signal:

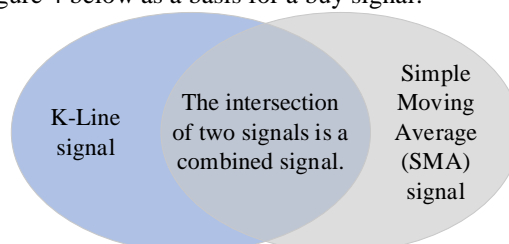

Source: This study

Figure 4: CSA

### K-Line Indicator - Three-Day Reversal Pattern

There are eight types of three-day reversal pattern proposed by Caginalp and Laurent (1998), including four uptrend three-day reversal pattern and four downtrend three-day reversal pattern. The scope of our study only includes the four downtrend three-day reversal pattern (later referred to as the four key K-line) and are identified as the "K-Line signal" of the combined signal indicator in our study.

The common ground of the four key K-lines is that the stock price is in a downtrend. In our study, a downtrend can be determined by the correlation between the mid-term (60-day) moving average and the short-term (5-day or 10-day) moving average. When the mid-term moving average is higher than the short-term moving average, it means that the stock price is in a downtrend, as shown in Figure 5 below.

Figure 5 shows that the purple SMA line is the 60-day SMA, the white line is the 20-day SMA, the yellow line is the 10-day SMA, and the blue line is the 5-day SMA. In Figure 5 the 60-day SMA is higher than the 10-day SMA and the 5-day SMA, indicating that the stock price is in a downtrend.



Source: Taiwan PC Home Stock.  
Figure 5: Downtrend Legend

Our study defines the downtrend of "Key K-Lines" are as follows:

1. 60-day SMA is greater than 5-day SMA (code: 60gt5), and the lowest 5-day SMA of t+1 to t+3 is in decline.
2. 60-day SMA is greater than 10-day SMA (code: 60gt10), and the lowest 5-day SMA of t+1 to t+3 is in decline.

Cong-Han Zheng (2020) used the three-day reversal patterns proposed by Caginalp and Laurent (1998) to investigate the return of all listed stocks in the Taiwan stock market. In this study we use the same characteristics of the four downward three-day reversal patterns he summarized below.

#### 1. Three White Soldier (TWS):

- a. Individual stock price was in a downtrend.
- b. Closing price of t+3 is greater than t+2, and is greater than t+1.
- c. t+1 closing price is greater than t+2 opening price is greater than t+1 opening price.
- d. t+2 closing price is greater than t+3 opening price is greater than t+2 opening price.

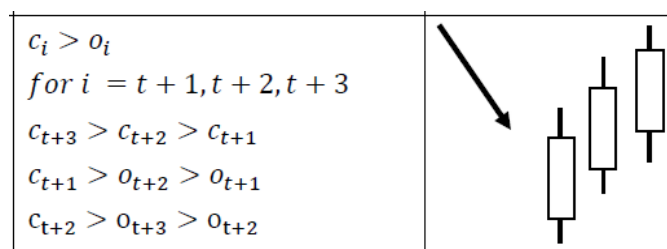

Source: Cong-Han Zheng (2020)  
Figure 6: Three White Soldier (TWS)

#### 2. Three inside up (TIU):

- a. Individual stock price originally in a downtrend.
- b. t+1 opening price is greater than the closing price.
- c. t+1 opening price is greater than t+2 opening price, and t+1 opening price is greater than t+1 closing price.
- d. t+1 opening price is greater than t+2 closing price, and t+1 opening price is greater than equal to t+1 closing price.
- e. t+3 closing price is greater than the t+3 opening price and the t+3 closing price is greater than the t+1 opening price.

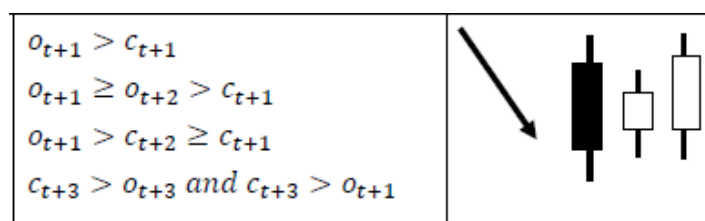

Source: Cong-Han Zheng (2020).

Figure 7: Three inside up (TIU)

### 3. Moving Star (MS):

- Individual stock price is originally in a downtrend
- t+1 opening price is greater than the closing price.
- t+2 opening price is not equal to the closing price.
- t+1 closing price is greater than t+2 closing price and t+1 closing price is greater than t+2 opening price.
- t+3 closing price is greater than t+3 opening price and t+3 closing price is higher than t+1 (closing price + (opening price - closing price)/2).

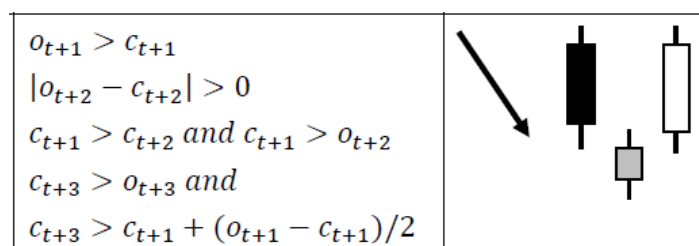

Source: Cong-Han Zheng (2020)

Figure 8: Moving Star (MS)

### 4. Three outside up (TOU):

- Individual stock price was in a downtrend.
- t+1 is in a downtrend and the opening price of the day is greater than the closing price.
- The closing price of t+2 is greater than the opening price of t+1, the opening price of t+1 is greater than the closing price of t+1, and the closing price of t+1 is greater than the opening price of t+2.
- The closing price of t+3 is greater than the opening price and the closing price of t+3 is greater than the closing price of t+2.

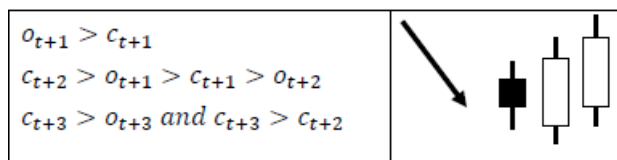

Source: Cong-Han Zheng (2020)

Figure 9: Three outside up (TOU)

### Simple Moving Average

Simple moving averages (hereinafter referred to as SMAs) are one of the reference indicators for determining the trend of the stock market. SMA information is commonly used in the market, such as 5-day (weekly average), 10-day (bi-weekly average), 20-day (monthly average), and 60-day (quarterly average), etc. In our study, we use the daily trading information of individual stocks in the Taiwan Stock Exchange (TWSE) to compute the SMA. The formula of SMA is  $\frac{C_1+C_2+\dots+C_n}{n}$ , where C is the daily closing price and n is the total number of days.

In our study, we will compare the following two SMA golden cross, which are used as one of the elements of the SMA in a combined signal:

- The 5-day SMA crosses above the 10-day SMA. (code: 5gt10)
- The 5-day SMA crosses above the 20-day SMA. (code: 5gt20)

### Signal Parameter

According to the research methodology, our study identifies six signal parameters as Table 2 below. No.1 to No.4 are combined signal and No.5 to No.6 are signal signal.



Table 2: Signal Parameter

No.	Signal Type	Key K-line Downtrend Code	SMA Golden Cross Code
1	Combined Signal	60gt5	5gt20
2	Combined Signal	60gt10	5gt20
3	Combined Signal	60gt5	5gt10
4	Combined Signal	60gt10	5gt10
5	Single Signal	60gt10	na
6	Single Signal	60gt5	na

Source: This study.

The buying strategy of our study is that when a stock meets the conditions of the K-line combined signal (t+3), we buy the stock if the stock price is lower than mid-point price of t+3 during next day (t+4) to the next 18 days (t+21).

### Stock Holding and Exit Strategies

Our study adopts the 5-day SMA as the basis for judging the downtrend of the key K-lines, which means that the 5-day period is also used as a judgment for the stock price trend turnaround, so the stock will be held at least for 5 days to monitor the subsequent ups and downs after purchasing. In addition, considering the objective of creating effective profit within one month (20 trading days), the holding strategy of this study is as follows:

1. Hold for at least 5 days after purchase.
2. The maximum number of days to buy and hold is set at 5, 10, 15 or 20 days.

The exit strategy is to sell a stock when the stock price reaches the stop-loss point or take-profit point before the preset maximum holding period. If the stop-loss point or take-profit point is not reached before preset maximum holding period, the stock will be sold on the last day of the maximum holding period.

The stop-loss point and take-profit point range in our study is from 2% to 6% as shown in Table 3 below. Take "6% stop-loss point, 6% take-profit point and 20 days Maximum of days holding the stock" combination as an example to illustrate the following scenarios to sell the stock:

1. Sell the stock if the stock price reaches 6% profit before reaches 20 days after purchased the stock, the experimental assumption is that the stock price can be sold when the stock price reaches 6% increase by programmed automated trading.
2. Sell the stock if the stock price loss reaches 6% before reaches 20 days after purchased the stock, the experimental assumption is that the stock price can be sold when the stock price falls by 6% through programmed automatic trading.
3. Sell the stock if the stock price has not reached 6% stop-loss point or 6% take-profit point within 20 days after purchasing the stock.

Table 3: Exit strategy matrix

Stop-Loss Point		Take-Profit Point		Maximum Holding Period
2%		2%		5 days
3%		3%		10 days
4%	X	4%	X	15 days
5%		5%		20 days
6%		6%		

Source: This study.

According to the matrix, we will have 100 possible conditions to sell the stock ( $5 \times 5 \times 4 = 100$ ).

### Combined Signal Performance Verification

The research question of our study is short-term trading, and it is suitable to look for stocks with relatively high price volatility as the research subject. According to Ching-Ho Chen (1992), "the increase in average monthly trading volume will result in high volatility in the average daily stock return." Therefore, the electronic stocks are selected as the target of our study, and the historical trading data from January 2012 to December 2021 are used to verify the return of the combined K-line signal consisting of the Key K-line and the Simple Moving Average (SMA).

The performance verification is conducted by simulated trading (refer to Figure 10 below for the simulated trading process), where each trade is bought at NT\$200,000 and its return is calculated.

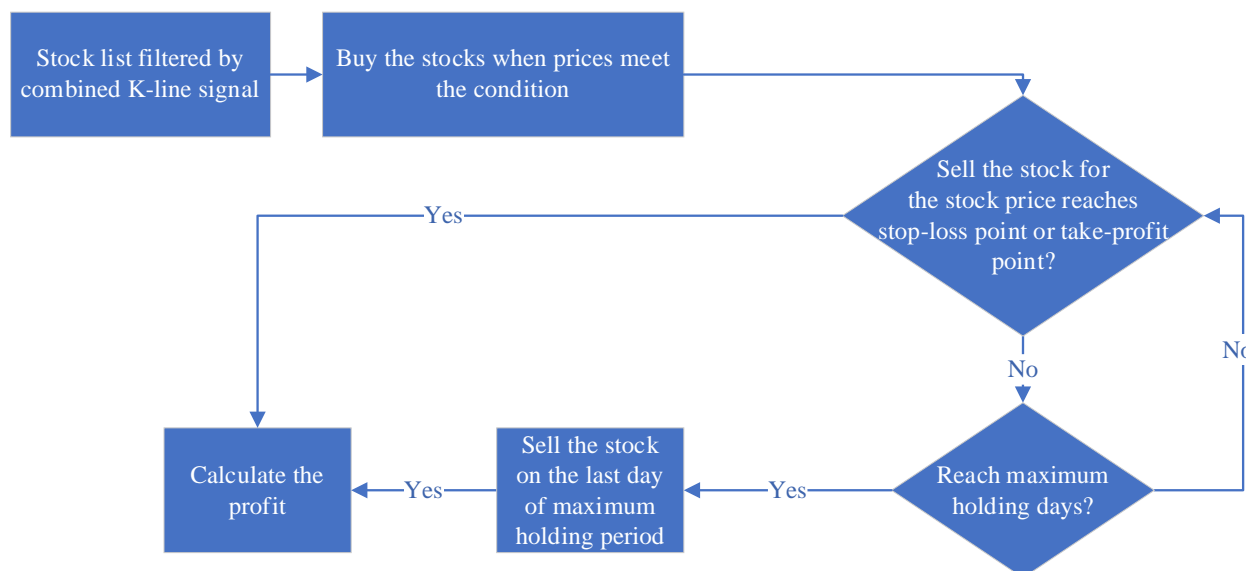

Source: This study  
Figure 10: Research flow

## RESULTS

In our study, the daily trading data of electronic stocks (420 stocks in total) for the past ten years (January 2012 to December 2021) is used as the experimental data, and NT\$200,000 is invested each time when a buy signal occurs. According to permutations of Table 2 and Table 3 items, we have generated a total of 600 buy-sell strategies, which are classified into 6 types based on the Key K-line and ranked in descending order of the average return as shown in the following Table 4 in order to select parameters with the best performance.

Take No.1 row of Table 4 for example, the “TWS-60gt5-5gt20” combined signal has a total of 3,300 simulated trades from 2012 to 2021. The average return is 1.56%, which is the highest among the 6 sets of K-line signals.

According to current finding, we could answer our RQ1 that a combined K-line signal yields a better return than a single signal.

Table 4: TWS Investment Performance.

No.	Signal Type	Key K-line	Data Period	Total Transaction Count	Profiting Possibility	Average Return
1	Combined Signal	TWS-60gt5-5gt20	2012 to 2021	3,300	69.24%	1.56%
2	Combined Signal	TWS -60gt10-5gt20	2012 to 2021	3,750	66.59%	1.32%
3	Combined Signal	TWS -60gt10-5gt10	2012 to 2021	7,875	62.44%	0.86%
4	Combined Signal	TWS -60gt5-5gt10	2012 to 2021	7,025	61.94%	0.83%
5	Single Signal	TWS -60gt10-na	2012 to 2021	24,138	54.66%	0.29%
6	Single Signal	TWS -60gt5-na	2012 to 2021	24,213	53.43%	0.20%

Source: This study.

### Optimize the Parameter of Key K-Line

Table 4 indicates the best performance is the average return of 1.56%. However, we aim to achieve performance that exceeds the effective profit threshold (1.56%) we defined previously in our study, so in this section we try to enhance the performance of average return by giving more stringent condition of K-line pattern.

To achieve this, we refer to the K-line characteristics of the Three White Soldier (TWS) mentioned in Figure 6, the following conditions are added:

1. The t+3 condition is a solid upward K pattern. Therefore, the new parameter filters out the K pattern of t+3 without a clear signal of a solid upward K pattern. The formula is as follows, where C is closing price and O is opening price.  

$$((C_{t+3} - O_{t+3}) / O_{t+3}) > 0.004$$
2. The t+3 condition is a solid upward K pattern. Therefore, the new parameter filters out the signal with a long upper wick of t+3 K pattern, with the following formula, where H is the maximum price, C is closing price, and O is opening price.  

$$((H_{t+3} - C_{t+3}) / (C_{t+3} - O_{t+3})) \leq 1$$
3. In our study, the 60-day SMA was used to judge the downward trend, therefore, we filter out the pattern which the highest price of t+3 close to the 60-day SMA as follows, where MA60 is 60-day SMA and C is closing price.  

$$((MA60_{t+3} - C_{t+3}) / MA60_{t+3}) \geq 0.03$$
4. The t+3 maximum is greater than the t+2 maximum by the following formula, where H is maximum price.

$$H_{t+3} > H_{t+2}$$

After optimizing the parameter, the best average return of investment increased to 2.21% as shown in Table 5 below, this performance exceeds the effective profitability threshold of 1.56% as defined previously in our study.

Table 5: TWS Investment Performance.

No.	Signal Type	Key K-line	Data Period	Total Transaction Count	Profiting Possibility	Average Return
1	Combined Signal	TWS-60gt10-5gt20	2012 to 2021	950	76.95%	2.21%
2	Combined Signal	TWS -60gt5-5gt20	2012 to 2021	950	76.95%	2.21%
3	Combined Signal	TWS -60gt10-5gt10	2012 to 2021	3,500	68.26%	1.24%
4	Combined Signal	TWS -60gt5-5gt10	2012 to 2021	3,325	67.94%	1.22%
5	Single Signal	TWS -60gt10-na	2012 to 2021	11,218	57.23%	0.42%
6	Single Signal	TWS -60gt5-na	2012 to 2021	11,143	56.45%	0.37%

Source: This study.

### Exit Strategies Performance Comparison

According to the experimental results in Table 5, the highest average return comes from the "TWS-60gt10-5gt20" combined signal, and then we go further to explore the best exit strategies for this group. By listing out all the combinations of stop-loss point, take-profit point and maximum holding period for this combined signal (TWS-60gt10-5gt20), we have generated 100 performance results, which are ranked according to the average return in descending order as shown in Appendix A.

The top 10 combinations of Appendix A are extracted and listed in Table 6, and the first row (No.1) is taken as an example, the total transaction count of the TWS-60gt10-5gt20 signal from 2012 to 2021 is 10, with an average return of 4.51%, under the scenarios of setting the take-profit point at 6%, the stop-loss point at 4% and the maximum holding period at 20 days.

Table 6: Exit Strategies Performance Comparison - TWS (Top 10 record)

No.	Key K-line	Data Period	Take-Profit Point (%)	Stop-Loss Point (%)	Max. Holding period	Total Transaction Count	Profiting Possibility	Average Return
1	TWS-60gt10-5gt20	2012 to 2021	6	4	20	10	90.00%	4.51%
2	TWS-60gt10-5gt20	2012 to 2021	6	5	20	10	90.00%	4.41%
3	TWS-60gt10-5gt20	2012 to 2021	6	6	20	10	90.00%	4.31%
4	TWS-60gt10-5gt20	2012 to 2021	6	3	20	10	80.00%	3.72%
5	TWS-60gt10-5gt20	2012 to 2021	5	4	20	10	90.00%	3.67%
6	TWS-60gt10-5gt20	2012 to 2021	5	5	20	10	90.00%	3.57%
7	TWS-60gt10-5gt20	2012 to 2021	6	4	15	10	80.00%	3.49%
8	TWS-60gt10-5gt20	2012 to 2021	5	6	20	10	90.00%	3.47%
9	TWS-60gt10-5gt20	2012 to 2021	6	5	15	10	80.00%	3.39%
10	TWS-60gt10-5gt20	2012 to 2021	6	4	10	9	77.78%	3.34%

Source: This study.

### Applying Best Buy-Sell Strategy to 2022 Data

Table 5 has shown that the "TWS-60gt10-5gt20" group has the best simulated return of investment from the data of the past ten years. And in Table 6 we can also see that the best exit strategy for the "TWS-60gt10-5gt20" group is to set the take-profit point, stop-loss point and maximum holding period as 6%, 4%, and 20 days respectively. So the next step is to apply the best buy-sell strategy to the 2022 data to verify our initial findings. The results of the 2022 TWS stock trading simulation are shown in Table 7 below. After applying the TWS technical analysis to the 2022 data, our system recommends 3 stocks for investors to purchase

Table 7: Three White Soldier (TWS) Performance Test In 2022

No.	Key K-line	Stock ID	Signal Occurring Date	Selling Date	Purchase Price (NT\$/per share)	Selling Price (NT\$/per share)	Return of Investment	Max. Holding Period
1	TWS	3669	3-Nov-2022	23-Nov-2022	41.35	43.83	6.00%	14
2	TWS	3679	27-Jul-2022	4-Aug-2022	73.1	77.49	6.00%	6
3	TWS	8112	3-Nov-2022	11-Nov-2022	34.275	36.33	6.00%	6
<b>Average return</b>							<b>6.00%</b>	

Source: This study.

Take trade #1 (stock ID 3669) as an example, the combined signal (TWS) is detected once on November 3, 2022, and so the stock is purchased for NT\$200,000 at a price of NT\$41.35 per share on the next day, and then sold when the price had risen to reach the take-profit point of 6% set by our study. The exit price of the stock is NT\$43.83, with a return of 6%.

### Test Investment Performance of Four Key K-line in 2022

By applying the same experimental procedures for TWS to the rest of the Key K-lines, our system has detected more profitable opportunities in the 2022 dataset.

As is shown in Table 8 below, 30 qualified investment opportunities are found in 2022 with holding period ranging from 2 to 20 days, of which 4 trades lost and 26 trades gained, giving a profiting possibility of 86.7% (26 profiting cases/30 trades). The return of investment for the 30 trades range from -4% to 6.01%, and the average return of those 30 investment opportunities is 4.16%, which is higher than the effective profitability threshold of 1.56% as defined previously in our study.

Table 8: Four Key K-Line Performance test in 2022

No.	Key K-line	Stock ID	Signal Occurring Date	Selling Date	Purchase Price (NT\$/per share)	Selling Price (NT\$/per share)	Return of Investment	Max. Holding Period
1	TWS	3669	3-Nov-2022	23-Nov-2022	41.35	43.83	6.00%	14
2	TWS	3679	27-Jul-2022	4-Aug-2022	73.1	77.49	6.00%	6
3	TWS	8112	3-Nov-2022	11-Nov-2022	34.275	36.33	6.00%	6
4	TOU	2359	11/2/2022	23.425	24.83	11,996	6.00%	6
5	TOU	3016	5/11/2022	94.85	100.54	11,998	6.00%	5
6	TOU	3034	5/11/2022	388.75	412.08	12,003	6.00%	15
7	TOU	3583	5/11/2022	80.6	85.44	12,010	6.01%	5
8	TOU	4938	11/7/2022	57.3	60.74	12,007	6.00%	5
9	TOU	4977	11/4/2022	94.85	100.54	11,998	6.00%	2
10	TOU	6152	5/11/2022	8.63	9.15	12,051	6.03%	3
11	TOU	6168	11/2/2022	16.125	17.09	11,969	5.98%	3
12	TOU	8213	8/1/2022	37.25	38	4,027	2.01%	20
13	MS	2356	10/20/2022	22.975	24.35	11,970	5.99%	7
14	MS	3015	8/5/2022	36.05	38.21	11,983	5.99%	5
15	MS	3050	4/13/2022	18.125	19.21	11,972	5.99%	2
16	MS	3305	8/5/2022	52.4	55.54	11,985	5.99%	6
17	MS	3311	4/8/2022	33.6	32.4	-7,143	-3.57%	20
18	MS	6770	4/6/2022	52.85	54.1	4,730	2.37%	18
19	MS	8011	8/5/2022	14.7	15.58	11,973	5.99%	2
20	TIU	2357	5/30/2022	334.75	321.36	-8,000	-4.00%	13
21	TIU	2426	7/14/2022	18.425	19.35	10,041	5.02%	4
22	TIU	2480	8/8/2022	86.9	83.42	-8,009	-4.00%	8
23	TIU	2485	11/1/2022	16.7	17.54	10,060	5.03%	7
24	TIU	3138	11/24/2022	138.75	145.69	10,004	5.00%	6
25	TIU	3338	8/1/2022	41.3	43.37	10,024	5.01%	14
26	TIU	3416	8/12/2022	76.1	79.91	10,013	5.01%	14
27	TIU	6412	5/26/2022	69.7	73.19	10,014	5.01%	8
28	TIU	6477	11/2/2022	42.675	44.81	10,006	5.00%	2
29	TIU	6706	7/14/2022	119.25	114.48	-8,000	-4.00%	2
30	TIU	8103	7/14/2022	34.925	36.67	9,993	5.00%	5
<b>Average Return</b>							<b>4.16%</b>	

Source: This study.

The four key K-lines are compared according to their average return, profiting possibility, total transaction count, and total amount of profit, as is shown in Tables 9. Taking the TWS and TIU signals for example, since the average return of the former is higher than the latter (6%>2.55%), it is easy for us to give a false conclusion that the performance of TWS is better. As a matter of fact, TWS has only three trading opportunities in 2022, which are quite few compared to that of TIU (3<11), and therefore the total profit of TWS in 2022 is less than that of TIU (\$ 35,997< NT\$ 56,146). As a result, it is suggested to compare key K-line signals carefully in every aspect in real life practice.

As we can see in Table 9, the four key K-line signals all generate profits higher than the effective profits threshold of 1.56%, which means that a positive answer should be given to RQ2 that combined K-line signal can be used as a hint for investors to enter the market and is able to generate effective profits within one month.

Table 9: Performance of four key K-line combination signal in 2022

No.	Key K-line	Average Return	Profiting Possibility	Total Transaction Count	Total Profit
1	Three White Soldier (TWS)	6%	100%	3	NT\$ 35,997
2	Three inside up (TIU)	2.55%	81.81%	11	NT\$ 56,146
3	Moving Star (MS)	4.11%	85.71%	7	NT\$ 57,470
4	Three outside up (TOU)	5.56%	100%	9	NT\$ 100,059

Source: This study.

## CONCLUSION AND DISCUSSION

### Conclusion

Our study uses K-line and simple moving average (SMA) to form a combined signal for stock price prediction, and explores the application of the combined signal for effective profit-taking within one month. In the end, we arrive at the following conclusions:

1. According to the results in Table 5, the return rates of the combined signal indicators are all better than those of single signal indicators.
2. The result of the study by Cong-Han Zheng (2020) states that "no significant positive average return is obtained regardless of the graphical definition". However, our study adopts both SMA (Simple Moving Average) indicators as well as K-line technical indicators with totally different parameters to form a combined signal, and the result proves that a positive return can be obtained in Taiwan electronics stocks, and furthermore, the combined signals can help to increase the return of investment.
3. The combined signals used in our study can be a hint for investors to enter the market, and have a chance to make effective profits within one month.
4. Max Jönsson (2016) states that "K-line information has a reference value for a period of 7 to 10 days". This study empirically examines K-line combinations, and according to the 2022 data test results (see Table 8), the reference period can be extended to 20 days.

### Discussion

The four "three-day reversal upward K-indicators" proposed by Caginalp and Laurent (1998) can be presented with mathematical formulas as well as K-line graphical patterns, and the former has less stringent conditions than the latter. This echoes the conclusion of Lv Tao, Yongtao Hao, Hao Yijie, and Shen Chunfeng (2017) saying that "There are definitely some spurious patterns in the existing K-line patterns. Therefore, in order to improve the stock prediction performance based on K-line patterns, we need to further classify the existing patterns based on the shape feature".

Based on the experimental results of Taiwan's electronics stocks, this study further adjusts the formulas of the related K-line signals to improve the return and profitability. In the future, if the methodology of our study is to be applied to stocks in other industries, the applicability of the parameters should be reassessed and fine-tuned.

## REFERENCES

- Caginalp, G., & Laurent, H. (1998). The predictive power of price patterns. *Applied Mathematical Finance*, 5, 181–205. <https://doi.org/10.1080/135048698334346>
- Chien-Sheng Chen (2020). A Study on the Investment Performance of Trading Strategies in Taiwan Stock Market and Relationship of Technical Indicators, Investor Sentiment, Foreign Institutional Investors Net Buying/Selling (Master's thesis, National Taipei University, Taiwan).
- Tsung-Wen Hu (2003). The Technical Analysis on the Taiwan Stock Market: Combined Signal Approach (Master's thesis, Chaoyang University of Technology, Taiwan).
- Yung-Chun Hsu (2015). Literature Review for Empirical Studies of Technical Analysis in Taiwan Stock Market - Using MA, KD, RSI, and MACD As Technical Indexes (Master's thesis, Asia University, Taiwan).
- Max Jönsson (2016). The Predictive Power of Candlestick Patterns (Bachelor Thesis, Lund University, Sweden).
- Kuan-Cheng Ko, Hsiang-Ju Su, Shinn-Juh Lin, Hsiang-Hui Chu (2016). The Impact of Technical Analysis on Volatility and Size Effects in Taiwan Stock Marke. *Journal of Management and Business Research*, 33(2), 281-309. [https://jom.management.org.tw/eng/search\\_detail.php?gid=683](https://jom.management.org.tw/eng/search_detail.php?gid=683)
- Camillo Lento (2009), "The Combined Signal Approach to Technical Analysis: A Review & Commentary", *SSRN Electronic Journal*, 1410899, pp. 8. <https://doi.org/10.2139/ssrn.1410899>
- Liang-Chun Li (2003). The Research of the Effectiveness of Technical Analysis in Taiwan Stock Market (Master's thesis, Shih Chien University, Taiwan).
- Sheng-Yuan Mou (2013). An Empirical Study of Technical Analysis in Taiwan Stock Market—Using KD, RSI, MACD ,DMI as Technical Indexes (Master's thesis, I-Shou University, Taiwan).
- Hui-Chen Shen (2021). An Empirical Study of Technical Analysis in Taiwan Stock Market: The Application of Multiple Technical Analysis Indicators (Master's thesis, National Changhua University of Education, Taiwan).
- Lv Tao, Yongtao Hao, Hao Yijie, and Shen Chunfeng (2017), "K-Line Patterns' Predictive Power Analysis Using the Methods of Similarity Match and Clustering", *Mathematical Problems in Engineering*. Volume 2017, Article ID 3096917, pp. 11. <https://doi.org/10.1155/2017/3096917>

- Tung-Chuan Wang (2018). An Empirical Study on the Technical Performance of Taiwan Stock Market - A Case Study of the Granville Rules (Master's thesis, China University of Technology, Taiwan).
- En Wei (2012). The Integration of Dempster-Shafer Theory and Combined Signal Approach in Technical Analysis of the Taiwan Stock Market (Master's thesis, Chaoyang University of Technology, Taiwan).
- Hsiu-yueh Wu (2013). Investment Performance of Technical Analysis on the Basis of Moving Average (Master's thesis, National Sun Yat-sen University, Taiwan).
- Cong-Han Zheng (2020). The Relationship between Investor Attention and Profitability of Candlestick Charting (Master's thesis, National Pingtung University, Taiwan).
- Cheng-Yu Zhu (2021). Reexamining Effectiveness of Stock Technical Analysis with Exponential Moving Average Approach (Master's thesis, National Yunlin University of Science and Technology, Taiwan).

**APPENDIX A: Exit Strategies Performance Comparison - TWS (All 100 record)**

No.	Key K-line	Data Period	Take-Profit point (%)	Stop-loss point (%)	Max. Holding Period	Total Transaction Count	Profiting Possibility	Average Return
1	TWS-60gt10-5gt20	2012 to 2021	6	4	20	10	90.00%	4.51%
2	TWS-60gt10-5gt20	2012 to 2021	6	5	20	10	90.00%	4.41%
3	TWS-60gt10-5gt20	2012 to 2021	6	6	20	10	90.00%	4.31%
4	TWS-60gt10-5gt20	2012 to 2021	6	3	20	10	80.00%	3.72%
5	TWS-60gt10-5gt20	2012 to 2021	5	4	20	10	90.00%	3.67%
6	TWS-60gt10-5gt20	2012 to 2021	5	5	20	10	90.00%	3.57%
7	TWS-60gt10-5gt20	2012 to 2021	6	4	15	10	80.00%	3.49%
8	TWS-60gt10-5gt20	2012 to 2021	5	6	20	10	90.00%	3.47%
9	TWS-60gt10-5gt20	2012 to 2021	6	5	15	10	80.00%	3.39%
10	TWS-60gt10-5gt20	2012 to 2021	6	4	10	9	77.78%	3.34%
11	TWS-60gt10-5gt20	2012 to 2021	6	6	15	10	80.00%	3.29%
12	TWS-60gt10-5gt20	2012 to 2021	6	5	10	9	77.78%	3.23%
13	TWS-60gt10-5gt20	2012 to 2021	5	4	15	10	80.00%	3.22%
14	TWS-60gt10-5gt20	2012 to 2021	4	4	20	10	90.00%	3.20%
15	TWS-60gt10-5gt20	2012 to 2021	6	3	15	10	70.00%	3.17%
16	TWS-60gt10-5gt20	2012 to 2021	5	4	10	9	77.78%	3.15%
17	TWS-60gt10-5gt20	2012 to 2021	5	5	15	10	80.00%	3.13%
18	TWS-60gt10-5gt20	2012 to 2021	6	3	10	9	77.78%	3.12%
19	TWS-60gt10-5gt20	2012 to 2021	6	6	10	9	77.78%	3.12%
20	TWS-60gt10-5gt20	2012 to 2021	6	2	20	10	70.00%	3.12%
21	TWS-60gt10-5gt20	2012 to 2021	4	5	20	10	90.00%	3.10%
22	TWS-60gt10-5gt20	2012 to 2021	5	5	10	9	77.78%	3.04%
23	TWS-60gt10-5gt20	2012 to 2021	5	6	15	10	80.00%	3.03%
24	TWS-60gt10-5gt20	2012 to 2021	4	6	20	10	90.00%	3.00%
25	TWS-60gt10-5gt20	2012 to 2021	5	3	20	10	80.00%	2.97%
26	TWS-60gt10-5gt20	2012 to 2021	5	3	10	9	77.78%	2.93%
27	TWS-60gt10-5gt20	2012 to 2021	5	6	10	9	77.78%	2.93%
28	TWS-60gt10-5gt20	2012 to 2021	4	4	15	10	80.00%	2.79%
29	TWS-60gt10-5gt20	2012 to 2021	4	5	15	10	80.00%	2.69%
30	TWS-60gt10-5gt20	2012 to 2021	4	4	10	9	77.78%	2.66%
31	TWS-60gt10-5gt20	2012 to 2021	4	3	20	10	80.00%	2.60%
32	TWS-60gt10-5gt20	2012 to 2021	4	6	15	10	80.00%	2.59%
33	TWS-60gt10-5gt20	2012 to 2021	6	2	15	10	60.00%	2.56%
34	TWS-60gt10-5gt20	2012 to 2021	4	5	10	9	77.78%	2.55%
35	TWS-60gt10-5gt20	2012 to 2021	6	2	10	9	66.67%	2.54%
36	TWS-60gt10-5gt20	2012 to 2021	5	3	15	10	70.00%	2.53%
37	TWS-60gt10-5gt20	2012 to 2021	5	2	20	10	70.00%	2.47%
38	TWS-60gt10-5gt20	2012 to 2021	4	3	10	9	77.78%	2.44%
39	TWS-60gt10-5gt20	2012 to 2021	4	6	10	9	77.78%	2.44%
40	TWS-60gt10-5gt20	2012 to 2021	5	2	10	9	66.67%	2.37%
41	TWS-60gt10-5gt20	2012 to 2021	3	4	20	10	90.00%	2.31%
42	TWS-60gt10-5gt20	2012 to 2021	3	5	20	10	90.00%	2.21%
43	TWS-60gt10-5gt20	2012 to 2021	4	2	20	10	70.00%	2.19%
44	TWS-60gt10-5gt20	2012 to 2021	4	3	15	10	70.00%	2.19%
45	TWS-60gt10-5gt20	2012 to 2021	3	6	20	10	90.00%	2.11%



46	TWS-60gt10-5gt20	2012 to 2021	6	3	5	9	66.67%	2.06%
47	TWS-60gt10-5gt20	2012 to 2021	6	2	5	9	66.67%	2.06%
48	TWS-60gt10-5gt20	2012 to 2021	6	6	5	9	66.67%	2.06%
49	TWS-60gt10-5gt20	2012 to 2021	6	5	5	9	66.67%	2.06%
50	TWS-60gt10-5gt20	2012 to 2021	6	4	5	9	66.67%	2.06%
51	TWS-60gt10-5gt20	2012 to 2021	5	2	15	10	60.00%	2.02%
52	TWS-60gt10-5gt20	2012 to 2021	3	2	20	10	80.00%	2.01%
53	TWS-60gt10-5gt20	2012 to 2021	3	4	15	10	80.00%	2.00%
54	TWS-60gt10-5gt20	2012 to 2021	4	2	10	9	66.67%	1.99%
55	TWS-60gt10-5gt20	2012 to 2021	3	4	10	9	77.78%	1.91%
56	TWS-60gt10-5gt20	2012 to 2021	3	2	10	9	77.78%	1.91%
57	TWS-60gt10-5gt20	2012 to 2021	3	5	15	10	80.00%	1.90%
58	TWS-60gt10-5gt20	2012 to 2021	3	3	20	10	80.00%	1.81%
59	TWS-60gt10-5gt20	2012 to 2021	3	2	5	9	77.78%	1.80%
60	TWS-60gt10-5gt20	2012 to 2021	3	6	5	9	77.78%	1.80%
61	TWS-60gt10-5gt20	2012 to 2021	3	5	5	9	77.78%	1.80%
62	TWS-60gt10-5gt20	2012 to 2021	3	4	5	9	77.78%	1.80%
63	TWS-60gt10-5gt20	2012 to 2021	3	3	5	9	77.78%	1.80%
64	TWS-60gt10-5gt20	2012 to 2021	3	6	15	10	80.00%	1.80%
65	TWS-60gt10-5gt20	2012 to 2021	3	5	10	9	77.78%	1.80%
66	TWS-60gt10-5gt20	2012 to 2021	4	2	15	10	60.00%	1.78%
67	TWS-60gt10-5gt20	2012 to 2021	3	2	15	10	70.00%	1.70%
68	TWS-60gt10-5gt20	2012 to 2021	3	3	10	9	77.78%	1.69%
69	TWS-60gt10-5gt20	2012 to 2021	3	6	10	9	77.78%	1.69%
70	TWS-60gt10-5gt20	2012 to 2021	5	4	5	9	66.67%	1.68%
71	TWS-60gt10-5gt20	2012 to 2021	5	3	5	9	66.67%	1.68%
72	TWS-60gt10-5gt20	2012 to 2021	5	2	5	9	66.67%	1.68%
73	TWS-60gt10-5gt20	2012 to 2021	5	6	5	9	66.67%	1.68%
74	TWS-60gt10-5gt20	2012 to 2021	5	5	5	9	66.67%	1.68%
75	TWS-60gt10-5gt20	2012 to 2021	3	3	15	10	70.00%	1.51%
76	TWS-60gt10-5gt20	2012 to 2021	2	4	20	10	90.00%	1.41%
77	TWS-60gt10-5gt20	2012 to 2021	4	5	5	9	66.67%	1.37%
78	TWS-60gt10-5gt20	2012 to 2021	4	4	5	9	66.67%	1.37%
79	TWS-60gt10-5gt20	2012 to 2021	4	3	5	9	66.67%	1.37%
80	TWS-60gt10-5gt20	2012 to 2021	4	2	5	9	66.67%	1.37%
81	TWS-60gt10-5gt20	2012 to 2021	4	6	5	9	66.67%	1.37%
82	TWS-60gt10-5gt20	2012 to 2021	2	5	20	10	90.00%	1.31%
83	TWS-60gt10-5gt20	2012 to 2021	2	3	5	9	77.78%	1.23%
84	TWS-60gt10-5gt20	2012 to 2021	2	2	5	9	77.78%	1.23%
85	TWS-60gt10-5gt20	2012 to 2021	2	6	5	9	77.78%	1.23%
86	TWS-60gt10-5gt20	2012 to 2021	2	5	5	9	77.78%	1.23%
87	TWS-60gt10-5gt20	2012 to 2021	2	4	5	9	77.78%	1.23%
88	TWS-60gt10-5gt20	2012 to 2021	2	6	20	10	90.00%	1.21%
89	TWS-60gt10-5gt20	2012 to 2021	2	2	20	10	80.00%	1.20%
90	TWS-60gt10-5gt20	2012 to 2021	2	4	15	10	80.00%	1.19%
91	TWS-60gt10-5gt20	2012 to 2021	2	4	10	9	77.78%	1.12%
92	TWS-60gt10-5gt20	2012 to 2021	2	2	10	9	77.78%	1.11%
93	TWS-60gt10-5gt20	2012 to 2021	2	5	15	10	80.00%	1.10%
94	TWS-60gt10-5gt20	2012 to 2021	2	3	20	10	80.00%	1.01%
95	TWS-60gt10-5gt20	2012 to 2021	2	5	10	9	77.78%	1.01%
96	TWS-60gt10-5gt20	2012 to 2021	2	6	15	10	80.00%	1.00%
97	TWS-60gt10-5gt20	2012 to 2021	2	2	15	10	70.00%	0.99%
98	TWS-60gt10-5gt20	2012 to 2021	2	3	10	9	77.78%	0.90%
99	TWS-60gt10-5gt20	2012 to 2021	2	6	10	9	77.78%	0.90%
100	TWS-60gt10-5gt20	2012 to 2021	2	3	15	10	70.00%	0.80%

Source: This study.



## Study on the Influencing Factors of Chinese Consumers' Continuous Purchase Intention on Cross-Border Beauty Products

Yi T. Zeng<sup>1</sup>  
Xuan B. Tang<sup>2</sup>  
Hong X. Lu<sup>3,\*</sup>

\*Corresponding author

<sup>1</sup> Associate Professor, Wuhan Business University, Wuhan, China, 346316766@qq.com

<sup>2</sup> Wuhan Business University, Wuhan, China, 512971642@qq.com

<sup>3</sup> Associate Professor, Hubei Business College, China, 33016548@qq.com

### ABSTRACT

In recent years, Chinese consumers have more and more demands for cross-border beauty products, so it is of practical significance to explore their continuous purchase intention. A research model is constructed based on SOR theory model in this study, in which the "stimulus" (S) factor is customer perceived value, including emotional value, functional value, social value; the "organic" (O) factors are perceived gain and customer satisfaction; "Response" (R) is consumers' continuous purchase intention. Based on 451 valid survey data, it is found that emotional value, functional value and social value have a positive impact on perceived gain and customer satisfaction, and perceived gain and customer satisfaction have a positive impact on continuous purchase intention, and perceived gain has a more significant impact on continuous purchase intention. In addition, perceived gain and customer satisfaction have partial mediation effects on the relationship between stimulus (S) and behavioral response (R). According to the research results, some suggestions are put forward for the merchants or enterprises engaged in cross-border beauty products industry.

*Keywords:* cross-border beauty products, SOR theory, continuous purchase intention, customer perceived value

### INTRODUCTION

iiMedia Research data shows that among China's cross-border e-commerce users, 56.19% consumers shop 3-6 times a month, 31.19% consumers shop less than 3 times a month, 11.14% consumers shop 6-9 times a month, 1.49% of consumers shop 10 or more times per month in 2022. It shows that Chinese e-commerce users are more enthusiastic about cross-border shopping. With the improvement of Chinese people's consumption level, people's demand for beauty products is increasing. Data from the Prospective Industry Research Institute of the General Administration of Customs of China show that China's cosmetics imports amounted to \$16.804 billion from January to November 2022. According to the "2023 Cross-border Import Consumption Report" released by Jingdong International, nutrition and health care, mother and infant products, beauty and skin care products, 3C categories and medical categories ranked top 5 in terms of consumption among cross-border imported goods, and 3C categories, personal care, household appliances, alcohol, beauty and skin care products grew faster year-on-year. With the birth of a large number of cross-border e-commerce platforms such as NetEase Koala, Tmall International, Jingdong International, and Ymatou, the cross-border beauty products available to Chinese consumers are increasing, and the range of choices are also expanding.

At present, there are few researches on cross-border beauty products in China. The existing researches mainly focus on customer satisfaction, analysis of influencing factors of cross-border beauty products online shopping decision-making, problems and countermeasures of cross-border beauty products e-commerce. Chai Zhengmeng, Men Yafang, and Liu Na (2020) collected data by means of online questionnaire survey, established an evaluation index system by using F-AHP, calculated the customer satisfaction of four cross-border beauty e-commerce companies such as Taobao and Jingdong, and gave suggestions on improving the customer satisfaction of the beauty industry on cross-border e-commerce platforms. Ma Liting and Yi Siqu (2020) analyzed the obstacles to the development of beauty products on cross-border e-commerce platforms, conducted an empirical study based on the technology acceptance model, and concluded that perceived usefulness, perceived ease of use, perceived safety, and perceived product quality significantly and positively affected the decision of cross-border online shopping of beauty products. Ye Yangxiang (2021) analyzed the development status and problems of B2C import cross-border e-commerce of beauty products, and proposed four strategic suggestions on optimizing business model, strengthening cooperation in emerging channels, integrating advantages, strengthening cooperation with offline stores, strengthening cooperation with cutting-edge products, expanding platform differentiation and innovative marketing.

To sum up, there is a lack of domestic research on the factors affecting Chinese consumers' continuous purchase intention of cross-border beauty products. Under the beauty economy background, consumers pay more attention to their appearance, and beauty products are increasingly popular with Chinese consumers. China has a large population and a large market volume.

Exploring the factors that affect Chinese consumers' continuous purchase intention of cross-border beauty products has certain reference significance for enterprises engaged in cross-border beauty trade. Based on SOR theoretical model, an influencing factor model of Chinese consumers' continuous purchase intention of cross-border beauty products is constructed in this study. Relying on the questionnaire survey data, this study explores the internal mechanism of Chinese consumers' continuous purchase intention of cross-border beauty products. It helps cross-border beauty trade enterprises to have a deeper understanding of consumers' internal psychological demands and implement effective operation management strategies.

### MODEL CONSTRUCTION AND RESEARCH HYPOTHESIS

#### Model Construction

SOR theory is one of the basic theories of modern cognitive psychology. SOR theory includes three elements: Stimulus, Organism, and Response. Izard (1977) pointed out that S (Stimulus Variables) is the stimulus of external environment, which is the root cause that affects the motivation of the agent. O (Organism Variables) refers to the psychological and cognitive changes of the organism with cognitive ability generated by stimulation. It is the internal process and structure of the agent between "stimulation" and "reaction". The process and structure are composed of activities such as perception, psychology, feeling and thinking. R (Response Variables) refers to the various responses and behaviors produced by the organism as a result of stimuli. SOR model is shown in Figure 1. The explanatory function of SOR theory generally lies in the analysis of the relationship between environmental stimuli and behavioral subjects' psychological activities and specific behaviors. Individuals' responses to external stimuli are not mechanical and passive, and people have subjective initiative. Individuals are capable of effective information processing under the stimulus to make rational behavioral decisions.

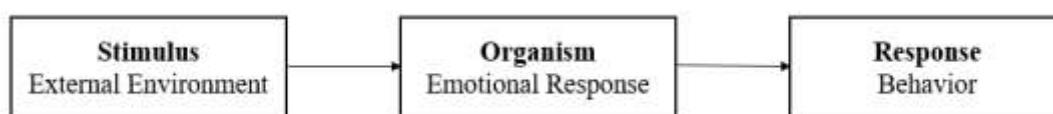
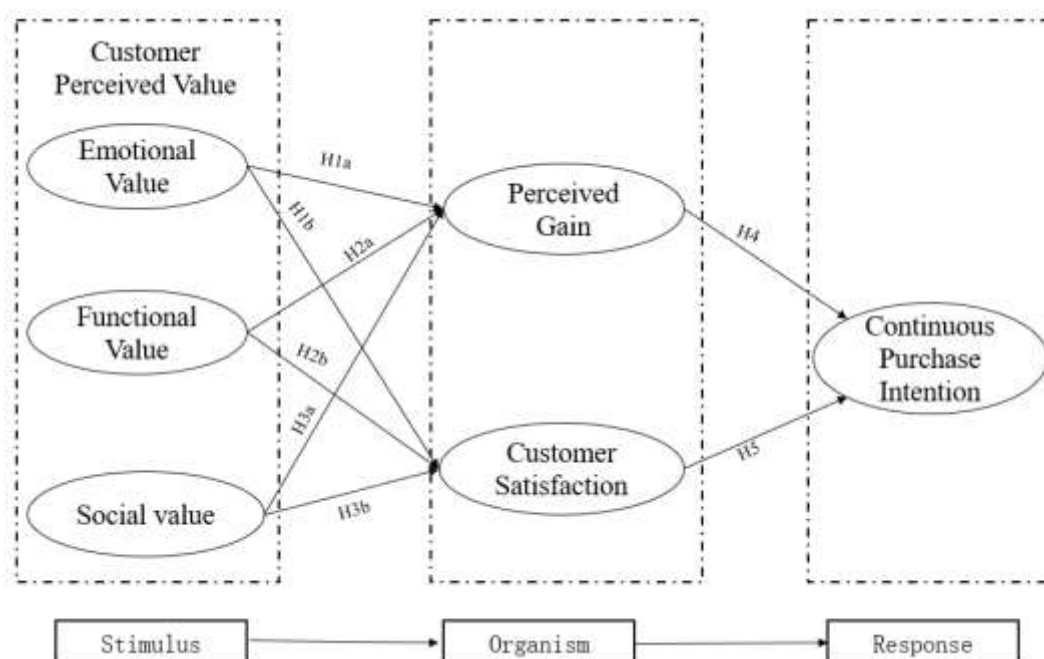

Fig 1: SOR Model

The application of SOR theory to the study of consumer behavior shows that consumers are affected by stimulus factors, and then they make emotional response, finally, they make a purchase. Zeithaml (1988) believes that customer perceived value is a subjective evaluation formed by customers after weighing perceived benefits and costs when purchasing products or services. Talwar (2021) believes that only good customer perception can prompt customers to make purchases. Chinese consumers' continuous purchase intention of cross-border beauty products is the result of a combination of internal and external factors. Based on the SOR theoretical model, the perceived value (emotional value, functional value, social value) is regarded as the factor (S) of consumers' stimulation, the internal psychological reaction (perceived gain, customer satisfaction) generated by consumers after stimulation is regarded as an organism with internal cognition (O), and the psychological reaction is continuous purchase intention of cross-border beauty products, which is regarded as a behavioral response (R). The specific research model is shown in Figure 2.



(Note: R is continuous purchase intention)

Fig 2: Research Model

## Research Hypothesis

Since Kotler et al. (1969) put forward the concept of customer perceived value, it has received extensive attention from scholars at home and abroad. Customer perceived value is not specific and invariable, and the dimensions of perceived value are divided differently in different research scenarios and objects. Sheth et al. (1991) divided customer perceived value into social value, emotional value, functional value, cognitive value and situational value. Sweeney et al. (2001) pointed out that customer perceived value can be mainly divided into four value dimensions: quality value, price value, emotional value and social value. Bai Changhong (2001) believes that customer perceived value generally includes functional value, emotional value and social value. Yang Xiaoyan et al. (2006) divided customer value into functional value, emotional value, social value and green value when they studied customer perceived value of green products. Zhang Guozheng et al. (2017) added and verified the safety value on the basis of functional value, emotional value and social value according to the safety characteristics of certified agricultural products when they studied the perceived value of customers of certified agricultural products. It can be seen that customers' perceived value of products with different characteristics is different. Based on previous studies, emotional value, functional value and social value are adopted to measure customer perceived value.

The research of customer perceived value is a very important part of consumer behavior. From the perspective of customers, the basic goal of their purchasing behavior is to obtain value. Zhang Guozheng et al. (2017) found that the functional value, emotional value and social value of customers' perceived value of certified agricultural products positively affected customers' purchase intention. Cui Dengfeng and Li Shumei (2018) believe that functional value, emotional value, social value and regional value are the most important driving factors affecting customers' purchasing behavior tendency, which can stimulate customers' purchasing intention and ultimately lead to their purchasing behavior. Zeithaml (1988) conducted a large number of studies from the perspective of consumer psychology by using empirical methods, and concluded that when consumers choose a product, the greater the perceived benefits brought by the product, the greater the perceived value of consumers will be enhanced, and a higher level of perceived value will improve consumers' purchase intention. Wang Ran, Ji Chunlan, and Xu Xiaoxue (2022) found that perceived value has a positive impact on perceived profit, and perceived profit also has a positive impact on purchase intention in their research on the influence mechanism of customers' perceived value on wine purchasing behavior. The perceived gain in the purchase process of cross-border beauty products is affected by the perceived value, thus affecting consumers' continuous purchase intention. Therefore, this study proposes the following hypothesis:

- H1a: Emotional value has a positive impact on perceived gain.
- H2a: Functional value has a positive effect on perceived gain.
- H3a: Social value has a positive effect on perceived gain.
- H4: Perceived gain has a positive effect on continuous purchase intention.

Customer satisfaction was proposed by American scholar Cardozo in 1965 and applied to the field of marketing. Customer satisfaction is influenced by many factors. Parasuraman (1994) believed that price, product and service quality affect customer satisfaction, and there is a functional relationship between customer satisfaction and price, product and service quality. Tu Hongbo, Xu Caosen and Zhao Xiaofei (2021) found that the higher the satisfaction or frequency of consumers' shopping experience, the stronger their endurance for the product or service, and the stronger the willingness of consumers to maintain the transaction relationship with the service provider. Wu Shuilong, Song Shuqi, Yuan Yongna et al. (2023) found that functional value, hedonic value and social value have a positive impact on customer satisfaction. In the process of purchasing cross-border beauty products, customer satisfaction is affected by perceived value, which affects consumers' continuous purchase intention. Therefore, this study proposes the following hypothesis:

- H1b: Emotional value has a positive impact on customer satisfaction.
- H2b: Functional value has a positive impact on customer satisfaction.
- H3b: Social value has a positive impact on customer satisfaction.
- H5: Customer satisfaction has a positive impact on continuous purchase intention.

## RESEARCH DESIGN

### Scale Design

The questionnaire scale is based on the maturity scale of other scholars and has been appropriately modified according to the specific situation of cross-border beauty products. The questionnaire is divided into two parts, the first part is the basic information of the survey subjects and the purchase of cross-border beauty products; the second part is the measurement subject, including 6 variables and 22 questions. The Likert 7-level scale is used, and 7 means "fully agree", 4 means "neutral", and 1 means "completely disagree".

### Data Collection

This questionnaire survey mainly uses QQ and WeChat platforms. In order to test the rationality of the questionnaire, a preliminary survey was conducted, and a total of 81 valid questionnaires were collected. SPSS software is used for analysis, and the reliability coefficient value is 0.935, greater than 0.9, indicating that the reliability quality of the research data is high. KMO and Bartlett tests are used to verify the validity. As shown in Table 1, the KMO value is 0.829, which is greater than 0.8, and the P-value significance level is less than 0.001. The research data is very suitable for extracting information. According to the test results of reliability and validity, the reliability and stability of the questionnaire are good, and it is suitable for further

survey. A total of 554 questionnaires are collected in this survey, of which 451 are valid, and the sample effective rate is 81.4%. As shown in Table2, since the research topic of this study focuses on cross-border beauty products, women and young people account for a large proportion of the surveyed objects. In addition, most of the respondents have a college education level or above and a medium income level, and they have the technology, knowledge and economic strength to purchase cross-border beauty products.

Table 1: KMO and Bartlett Test

KMO		0.829
	Approx. Chi-square	1295.825
Bartlett	<i>df</i>	231
	<i>P</i>	0.000

Table 2: Basic Information of Samples

Variable	Item	Percent
Gender	Male	14.4%
	Female	85.6%
Age	Under25	44.8%
	26-35	35.0%
	36-45	14.4%
	Over45	5.8%
Education	High school or less	4.4%
	Junior College	28.4%
	Undergraduate	54.3%
	Master degree or above	12.9%
Disposable monthly income (RMB)	Under1500	8.9%
	1501-3000	18.4%
	3001-4500	30.8%
	4501-6000	24.4%
	Over6000	17.5%

## DATA ANALYSIS

### Reliability Testing

The function of reliability test is to measure the stability and reliability of the scale to ensure that the scale is reliable. In this study, SPSS software is used to process the questionnaire data, and Cronbach's  $\alpha$  coefficient of each variable is obtained to verify the reliability of the research scale. The results are shown in Table 3. The Cronbach's  $\alpha$  values of all latent variables are greater than 0.80, according to Nunally J.C. Cronbach's  $\alpha$  coefficient should be greater than 0.7, which can confirm the high reliability of this scale.

Table 3: Reliability and Convergence Validity of Survey Data (n=351)

Variable	Number of Questions	CR	Cronbach's $\alpha$	AVE
EV	5	0.843	0.843	0.519
FV	4	0.803	0.800	0.506
SV	4	0.813	0.813	0.522
PG	3	0.835	0.836	0.627
ST	3	0.811	0.812	0.588
CPI	3	0.814	0.811	0.595

### Validity Testing

KMO and Bartlett tests were performed on the measurement items before exploratory factor analysis. As shown in Table4, KMO is 0.911, higher than the standard value of 0.8, and P-value significance level is less than 0.001, so it is suitable for factor analysis. The results of exploratory factor analysis are shown in Table5. Six factors are extracted, the eigenvalues are all greater than 1, the cumulative variance interpretation rate is 68.393%, greater than 60%, and the factor load of each item is above 0.6, greater than the standard value 0.5, indicating that the extracted factors are effective and have high interpretation power.

Table 4: KMO and Bartlett Test

KMO	0.911
Approx. Chi-square	4710.795
Bartlett	<i>df</i>
	231
	<i>p</i>
	0.000

Table 5: Exploratory Factor Analysis

Items	Factor Load Coefficient					
	Factor1	Factor 2	Factor 3	Factor 4	Factor 5	Factor 6
EV1	0.799					
EV2	0.671					
EV3	0.665					
EV4	0.685					
EV5	0.693					
FV1		0.723				
FV2		0.714				
FV3		0.756				
FV4		0.631				
SV1			0.716			
SV2			0.727			
SV3			0.680			
SV4			0.731			
PG1				0.759		
PG2				0.731		
PG3				0.820		
ST1					0.782	
ST2					0.800	
ST3					0.794	
CPI1						0.834
CPI2						0.856
CPI3						0.633
Feature Value (after rotation)	Root 3.267	2.586	0.794	2.284	2.240	2.114
Variance Interpretation Rate % (after rotation)	14.849 %	11.754%	11.615%	10.382%	10.184 %	9.609%
Cumulative Variance Interpretation Rate % (after rotation)	14.849 %	26.603%	38.218%	48.600%	58.784 %	68.393%

The confirmatory factor analysis results are shown in Table3 and Table6. The average extracted variance value (AVE) of all variables is greater than 0.5, the CR value is greater than 0.7, and the square root of AVE is greater than the correlation coefficient with other variables. It shows that it has good convergent validity and discriminative validity.

Table 6: Correlation among Constructs and the AVE Square Root

	EV	FV	SV	PG	CS	CPI
EV	0.519					
FV	0.668	0.506				
SV	0.676	0.687	0.522			
PG	0.620	0.631	0.614	0.627		
CS	0.540	0.542	0.542	0.429	0.588	
CPI	0.407	0.412	0.405	0.530	0.461	0.595
AVE Square Root	0.720	0.711	0.722	0.792	0.767	0.771

**Hypothesis Testing**

In this study, Amos24.0 is also used for model fitting and hypothesis testing. The fitting results between the sample data and the theoretical model are shown in Table7, and each fitting index meets the reference value standard, indicating that the overall fitting degree between the data and the model is good.

Table 7: Model Fit Indices for the Structural Model

Model fit indices	Reference value	Value of this model
CMIN/DF	<3	2.722
RMSEA	<0.10	0.062
TLI	>0.9	0.913
IFI	>0.9	0.926
NFI	>0.8	0.888
CFI	>0.9	0.925
RFI	>0.8	0.869
PCFI	>0.5	0.793
PNFI	>0.5	0.753

The result of hypothesis testing is shown in Figure3. Although the significance of each variable is different, a total of 8 hypotheses have been verified, that is, all hypotheses are supported.

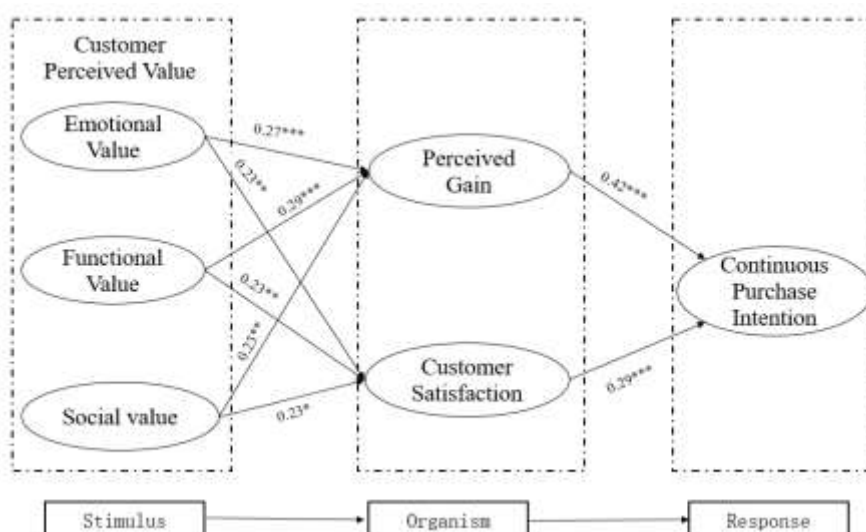

Note: (\*P<0.05, \*\*P<0.01, \*\*\*P<0.001)

Fig 3: Structural Model

### Mediation Effect

In order to have a further exploration on the influence of emotional value, functional value and social value on cross-border beauty product consumers' continuous purchase intention, Bootstrapping is used to sample repeatedly 5000 times to test the mediation effect of perceived gain and customer satisfaction in the model. This method can test several mediation effects simultaneously and test the overall mediation effect, and if the 95% confidence interval does not contain zero, the point estimate of the mediating effect is considered significant. The empirical results are shown in Table8, and the effects of all mediation path are significant. Both perceived gain and customer satisfaction play a partial mediating role between emotional value, functional value, social value and continuous purchase intention.

Table 8: Summary of Mediation Effects

Mediation Path	Total Effects	Mediation Effects	z Value	p Value	95%BootCI	Indirect EffectsResult
EV=>PG=>CPI	0.145**	0.030	1.804	0.071	0.018~0.083	0.094** Partial Mediation
EV=>CS=>CPI	0.145**	0.021	1.465	0.143	0.010~0.066	0.094** Partial Mediation
FV=>PG=>CPI	0.147**	0.038	2.057	0.040	0.016~0.087	0.087* Partial Mediation
FV=>CS=>CPI	0.147**	0.023	1.585	0.113	0.006~0.063	0.087* Partial Mediation
SV=>PG=>CPI	0.150**	0.032	2.003	0.045	0.014~0.075	0.096* Partial Mediation
SV=>CS=>CPI	0.150**	0.022	1.588	0.112	0.005~0.059	0.096* Partial Mediation

Note: (\*:  $p < 0.05$ , \*\*:  $p < 0.01$ )

### DISCUSSION

In general, the external environment (perceived value) stimulates the customers, and customers make emotional response (perceived gain, satisfaction), and then customers make behavioral responses (continuous purchase of cross-border beauty products). It conforms to the SOR theoretical model. In terms of perceived gain, the impact of each perceived value gradually decrease, which is shown as following: functional value (path coefficient: 0.29\*\*\*), emotional value (path coefficient: 0.27\*\*\*), and social value (path coefficient: 0.23\*\*). The reason is that with the improvement of people's quality of life, consumers care more about the function of the product, followed by emotional pleasure, and finally social value. Therefore, these dimensions have different effects on consumers' perceived gain. On the one hand, cross-border beauty products merchants or enterprises should find out what consumers expect for, pay attention to truly understand the needs of consumers, do a good job in the development of product functions, and provide products that can be truly beneficial to consumers to increase users' sense of benefit, thus increasing user stickiness. On the other hand, in the marketing process, cross-border beauty products merchants or enterprises should pay attention to the emotional needs of consumers, put themselves in the shoes of consumers, generate emotional resonance with consumers, and promote consumers to transfer into loyal consumers. In addition, cross-border beauty products merchants or enterprises in enhancing the social value and emotional value of consumers, but also to enhance the social value of consumers, so that high quality products become a booster in the social communication of consumers.

In terms of customer satisfaction, emotional value (path coefficient: 0.23\*\*), functional value (path coefficient: 0.23\*\*), and social value (path coefficient: 0.23\*) have almost the same impact, but the significance is slightly different. It shows that customer satisfaction, emotional value, functional value and social value all play an equally important role, and cross-border beauty products merchants or enterprises should pay attention to these three factors at the same time.

In terms of continuous purchase intention, perceived gain (path coefficient: 0.42\*\*\*) has a greater impact on consumers' continuous purchase intention than customer satisfaction (path coefficient: 0.29\*\*\*). Consumers will have a greater driving force to purchase when they perceive that the product brings them more benefits. Therefore, cross-border beauty product merchants or enterprises should start from the value provided by the product to make consumers feel benefited.

### CONCLUSION

Based on the SOR theoretical model, this study puts forward a model of factors affecting Chinese consumers' continuous purchase of cross-border beauty products, and conducts an empirical test on the model, and the research results have well verified the theoretical model. The main conclusions are as follows: Emotional value, functional value and social value all positively affect perceived gain and customer satisfaction, and perceived gain and customer satisfaction all positively affect continuous purchase intention. The results of mediation effect test are all partial mediation effect. As with most of studies, this study is not without its limitations. First, the 451 questionnaires obtained by the survey is relatively small for cross-border beauty products consumers. Since it is a sampling survey, the research conclusion can explain the problem to a certain extent, but it may lack in reliability. Second, emotional value, functional value and social value are selected as the stimuli of



the external environment, while perceived gain and customer satisfaction are selected as the emotional response of the consumers. The research scope is limited to a certain extent. In fact, there are more possible factors affecting Chinese consumers' continuous purchase of cross-border beauty products, such as safe value, price value, quality value. Future studies can supplement and expand this study, further examine other possible determinants, hoping to get a more reliable and complete conclusion.

#### ACKNOWLEDGMENT

This study is supported by the Major Program of Philosophy and Social Sciences for Higher Education Institutions in Hubei Province (pre-funded program of Provincial Social Science Foundation) (Grant No. 21ZD151)

#### REFERENCES

- Bai, C. H. (2001). Customer Value Research in the West and Its Practical Enlightenment. *Nankai Management Review*, (02), 51-5519. (in Chinese)
- Blue Bay Trade. (2023). Overview of China's Cosmetics Industry Import Trade in 2023. Retrieved from <https://baijiahao.baidu.com/s?id=1760960270062433291&wfr=spider&for=pc> (accessed March 23, 2023).
- Chai, Z. G., Men, Y. F., & Liu, N. (2020). Comprehensive Evaluation of Customer Satisfaction of cross-border beauty e-commerce based on F-AHP. *China's Collective Economy*, (18), 102-104. (in Chinese)
- Cui, D. F., & Li, S. M. (2018). Study on the Influence of Customers' Perceived Value of Characteristic Agricultural Products on Customers' Purchasing Behavior Tendency: Based on Multi-group Structural Equation Model. *Agricultural Technology Economy*, (12), 119-129. (in Chinese)
- Howard, J. A., Sheth, J. N. (1969). *The Theory of Buyer Behavior*, NY: John Willey and Sons.
- Iimedia Data Center. (2023). Cross-border E-commerce Industry Data Analysis: 56.19% of Consumers Cross-border Shopping 3-6 Times per Month. Retrieved from <https://www.iimedia.cn/c/1061/90700.html> (accessed Nov. 17, 2023).
- Izard, C.E. (1977). *Human Emotions*, New York: Plenum Press.
- Jingdong (2023). 2023 - Cross-border Import Consumption Report (in Chinese). Retrieved from <http://www.100ec.cn/detail--6626528.html> (accessed Apr. 18, 2023).
- Ma, L. T., & Yi, S. Q. (2019). Empirical Analysis of Influencing Factors of Cross-border Online Shopping Decision of Beauty Products Based on Technology Acceptance Model. *Journal of Wuyi University*, 39(04), 29-35. (in Chinese)
- Mehrabian, A., & Russell, J. A. (1974). *An Approach to Environmental Psychology*, Cambridge, MA: The MIT Press.
- Parasuraman, A., Eitam, V. A., & Berry, L. L. (1994). The Behavioral Consequences of Service Quality. *Journal of Marketing*, 58(111-124).
- Peng, B., & Wang, S. F. (2020). The Impact of Online Game Players' Satisfaction on Virtual Item Purchase Intention. *China's Circulation Economy*, 34(12), 51-59. (in Chinese)
- Ran, J. C. L., Xu, X. X., et al. (2021). Study on the Influence Mechanism of Customer Perceived Value on Wine Purchasing Behavior. *China Winemaking*, 41 (6), 249-253. (in Chinese)
- Sheth, J.N., Newman, B.I. (1991). Why We Buy What We Buy: A Theory of Consumption Values. *Journal of Business Research*, 22(2), 159~170.
- Shu, S. J., & Shao, J. (2021). Research on the Impact of Tourists' Perceived Value on the Purchase Intention of Cultural and Creative Products in the Palace Museum. *Resource Development and Market*, 37(04), 498-504. (in Chinese)
- Sweeney, J.C., & Soutar, G. N. (2001). Consumer Perceived Value: The Development of a Multiple Item Scale. *Journal of Retailing*, 77(2), 203-205. (in Chinese)
- Talwar, S., Jabeen, F., Tandon, A., Sakashita, M., & Dhir, A. (2021). What drives willingness to purchase and stated buying behavior toward organic food? A Stimulus-Organism-Behavior-Consequence (SOBC) perspective. *Journal of Cleaner Production*, 293, 125882.
- Tu, H. B., Xu, C. S., Zhao, X. F. (2021). Influence Mechanism of Consumers' Repurchase Intention on O2O Fresh E-commerce Platform. *China Circulation Economy*, 35(04), 38-47. (in Chinese)
- Wu, S. L., Song, S. Q., & Yuan, Y. N. (2023). The Influence of Customer Perceived Value on Customer Satisfaction: the Mediating Role of Self-Artificial Intelligence Connection. *Journal of Beijing Institute of Technology (Social Sciences Edition)*, 25(03), 117-128. (in Chinese)
- Yang, X. Y., & Zhou, Y. J. (2006). Green value: A New Dimension of Customer Perceived Value. *China Industrial Economics*, (07), 110-116. (in Chinese)
- Ye, Y. X. (2021). Status, Challenges and Strategies of Chinese Beauty Products Import Under the Effect of Cross-border E-commerce Giants. *Foreign Economic and Trade Practice*, (07), 58-61. (in Chinese)
- Zeithaml, V.A. (1988). Consumer Perceptions of Price, Quality and Value: A Means-end Model and Synthesis of Evidence. *Journal of Marketing*, 52(3), 2-22.
- Zhang, G. Z., Peng, C. Y., Zhang, F. F. et al. (2017). The Perceived Value of Agricultural Products and Its Influence on Purchasing Intention: An Empirical Analysis Based on Certified Agricultural Products. *Journal of Human Agricultural University (Social Sciences Edition)*, 18(02), 24-28. (in Chinese)
- Zhang, G. Z., Xu, Z., Tang, W. Y. (2017). Study on Tea Geographical Indication Premium Payment Willingness -- Taking Anhua Dark Tea as An Example. *Agricultural Technical Economics*, 2017(8), 110 ~ 116. (in Chinese)

## The Application of Digital Technology in the Protection of Architectural Cultural Heritage

Jie Wang<sup>1,\*</sup>  
Gabiella Medvegy<sup>2</sup>  
Jian Jun Hou<sup>3</sup>

\*Corresponding author

<sup>1</sup> Lecturer, Nanjing Institute of Technology, Nanjing, China, 34244119@qq.com

<sup>2</sup> Professor, University of Pécs, Pécs, Hungary, 15188368397@163.com

<sup>3</sup> Professor, Nanjing Institute of Technology, Nanjing, China, houjianjun@njit.edu.cn

### ABSTRACT

The development of digital technology has given us the ability to permanently preserve the historical and cultural information carried by architectural cultural heritage, which is a non-renewable and valuable historical and cultural resource. Digital technology provides a more convenient and efficient way of displaying and disseminating architectural cultural heritage, which is suitable for different geographical locations, cultural characteristics and preservation conditions, and enables the conservation of architectural cultural heritage to be completed with high quality and efficiency. With the continuous improvement of the digitization of cultural heritage, we should actively carry out the digital protection of architectural heritage, and always pay attention to the development and application of digital technology, and constantly explore and practice the new forms of digital technology in the field of architectural heritage protection.

Digital preservation is a new direction for the safeguarding of architectural cultural heritage. Through the systematic introduction of relevant digital technologies and the summary of experiences in the development practice, this paper explores the digital protection methods of architectural cultural heritage from the theoretical and practical operation level.

*Keywords:* Architectural cultural heritage, digital technology, protect, three-dimensional technology, and reality technology.

### INTRODUCTION

In 1992, in order to protect the world cultural heritage, UNESCO launched the "Memory of the World" project, which opened the door for digital technology to intervene in the study of cultural heritage, and this was the beginning of digital preservation of cultural heritage. In 2002, UNESCO launched the draft of "Guidelines for the Preservation of the Digital Heritage", and In 2003, UNESCO promulgated "Charter on the Preservation of the Digital Heritage", which provides reference and guidance for the digital protection of cultural heritage in all countries.

In the process of modernization, a large amount of precious architectural cultural heritage is facing unprecedented survival difficulties (Nathaniel, 2009). Each piece of architectural cultural heritage has its corresponding architectural history, architectural memories and folk customs, and it is often difficult for us to comprehensively and profoundly understand the historical and cultural information carried by architectural cultural heritage, which makes the public alienated from architectural cultural heritage, and therefore it is urgent to effectively develop, exploit and preserve architectural cultural heritage by reasonable means. Therefore, there is an urgent need to make use of reasonable means to effectively develop, utilize and protect the architectural cultural heritage. Digital technology has enriched the protection methods of the architectural cultural heritage, which can effectively realize the reproduction of architectural space (Wang *et al.*, 2023). Through the comprehensive application of digital acquisition, storage, processing, digital image technology, mapping and remote sensing, computer virtual reality and augmented reality technology, Internet and other technical methods, it presents a simulation scene of the whole process of the creation, the protection and inheritance of architectural cultural heritage, so that people can truly feel the actual state and the unique value of architectural cultural heritage.

### LITERATURE REVIEW

#### Abroad Research Status

Developed countries in Europe and the United States have their own characteristics in the field of digital architectural cultural heritage preservation, and have achieved fruitful and representative success cases and experiences (Murphy *et al.*, 2019). The United States is a world leader in the application of digital technology for cultural heritage, utilizing digital technology to carry out "The disappeared architectural heritage reproduction" project, such as the reconstruction of the Colosseum port in Rome and the virtual ancient city of Pompeii. etc.; In 2008, the Australian Centre for Interaction Design and Research (ACID) adopted digital restoration methods to restore the Sydney harbour to its original environment in the "Digital Songline" project, achieving the combination of digital technology with architectural cultural heritage. the United Kingdom completed the digital simulation

and virtual project of the ancient architecture “Top Ten World Architectural Heritage Sites in Scotland” for ancient buildings; Japan restored and reproduced the ancient features of Kyoto through virtual reality, 3D and other technologies. In 2018, CyArk cooperated with Oculus to develop the VR application “Masterworks: Journey Through History”. which allows users to explore famous historical sites and landmarks around the world with the help of virtual reality devices, including Thailand's ancient capital city of Ayutthaya, Wahad Temple in Peru, etc., providing viewers with an immersive and interactive virtual reality tour experience.

### Domestic Research Status

Western architectural cultural heritage protection theories were introduced to China in the early 20th century, under its influence, domestic scholars have further explored the “cultural heritage protection theories and methods combined with the characteristics of China's architectural cultural heritage” (Tong *et al.*, 2016). The study of cultural heritage digitization in China began in the 1990s, and the concept of “cultural heritage digitization” was initially proposed by scholar Wang Yaoxi (2009). It actively adopts new digital technology, and strives for more comprehensive protection, inheritance and utilization of architectural cultural heritage, and has achieved a series of results.

In addition to theoretical research, China has also carried out a large number of architectural cultural heritage protection projects based on digital technology. “Digital Dunhuang” project, which with virtual reality, augmented reality, interactive display as a digital technology inheritance pathway, breaking the limitations of traditional inheritance, and realizing the digital display and roaming technology of the Dunhuang grottoes cultural relics. In 2002, the School of Architecture of Tsinghua University launched the virtual Yuan Ming Yuan project. which uses computer graphics and other latest technological means to completely maintaining the style of the Yuanmingyuan ruins., and restore 2,000 digital architectural models and 120 sets of spatial and temporal scenes of different historical periods. In 2008, the Palace Museum cooperated with IBM to develop the “Forbidden City Beyond Time and Space”, which combines the architectural cultural heritage and digital technology, and enables the users to visit and watch 3D virtual palace buildings and historical relics through the Internet (Feng, 2017).

### Citespace Analysis

Through the search of literature about “digital architectural heritage” and the data analysis based on CiteSpace, it can be seen that since 2000, articles on the topic of digital architectural heritage began to appear, but in the following 10 years, the research progress was slow and the research results were very few. From 2010 to 2013 is the development stage, the digital architectural heritage has gradually attracted the attention of the research community, and the research in this field has continued to develop, but limited by the level of technology, the annual research results are not fruitful. Since 2016, thanks to the rapid development of information technology and the attention of the scholars, the theoretical research on the digital architectural heritage has advanced by leaps and bounds. Research hotspots and directions mainly in three-dimensional (3D) modeling, virtual reality, laser scanning, augmented reality, digital model, photogrammetry, bim, etc. (Figure 1), and the timeline diagram (Figure 3) shows the research context in the field of digital architectural heritage, and reflects the research hotspots and evolutionary processes in this field Hot spots. According to the structure and cluster of the CiteSpace map, calculate that the modular  $Q=0.6397$  and the silhouette  $S=0.8365$  (Figure 2), indicating that the development of this field has a high degree of fit.

### Top 15 Keywords with the Strongest Citation Bursts

Keywords	Year	Strength	Begin	End	2008 - 2022
laser scanning	2008	1.66	2009	2012	
3d modeling	2008	2.14	2012	2014	
virtual heritage	2008	1.32	2012	2017	
augmented reality	2008	1.61	2014	2016	
architectural heritage	2008	2.54	2015	2018	
digital model	2008	1.28	2015	2018	
digital archaeology	2008	1.05	2016	2017	
reconstruction	2008	2.5	2017	2018	
conservation	2008	2.09	2017	2018	
graphic documentation	2008	1.99	2017	2018	
laser scanner	2008	1.15	2017	2019	
bim	2008	0.99	2017	2020	
built heritage	2008	1.86	2018	2019	
accuracy	2008	1.77	2019	2020	
management	2008	1.67	2020	2022	

Source: This study.

Figure 1: Top 15 Keywords with the Strongest Citation Bursts (2008-2022).

```

CiteSpace, v. 6.1.R2 (64-bit) Basic
May 28, 2022 at 4:03:00 PM CST
WoS: /Users/imac/Desktop
Timespan: 2002-2022 (Slice Length=1)
Selection Criteria: g-index (k=25), LRF=3.0,
Network: N=285, E=962 (Density=0.0238)
Largest CC: 218 (76%)
Nodes Labeled: 1.0%
Pruning: None
Modularity Q=0.6397
Weighted Mean Silhouette S=0.8365
Harmonic Mean(Q, S)=0.725

```

Source: This study.

Figure 2: Parameter Computation of CiteSpace.

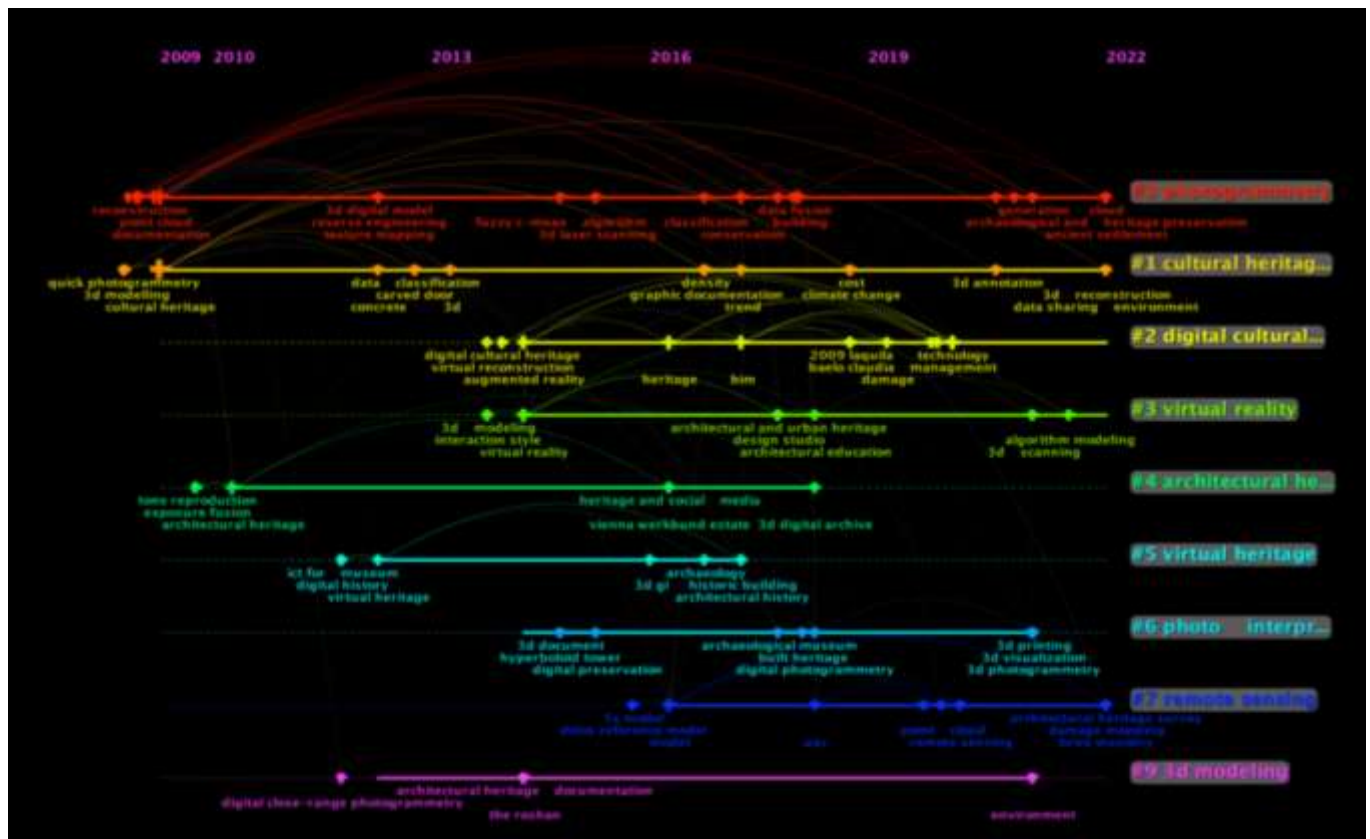

Source: This study.

Figure 3: Timeline diagram of digital architectural heritage research.

## FEATURES AND ADVANTAGES OF DIGITAL TECHNOLOGY APPLIED TO THE CONSERVATION OF ARCHITECTURAL CULTURAL HERITAGE

In the context of globalisation, countries are paying more and more attention to cultural heritage, and the rapid development of digital technology and its significant advantages have led to more and more digital technologies being used in the cause of architectural cultural heritage conservation (Zhao *et al.*, 2018). At present, the conversion of architectural cultural heritage into digital form has become a worldwide trend in cultural heritage conservation.

### Enabling Architectural Cultural Heritage to Transcend the Barriers of Time and Space

Digital technology has an inherent advantage in the representation of space and time. The virtual reality world built on the model of architectural cultural heritage is a three-dimensional historical place, reconstructing the "human-temporal" relationship, continuing the historical heritage of architectural cultural heritage (Ma, 2020). The spatial imagery and the value of the historical information behind it can be perceived by the user in an immersive way, which is more vivid and focused than the experience obtained through hearsay and reading. The architectural and cultural heritage that has emerged in the course of human social and historical development is a record of history across time, but it is difficult to escape the constraints of time and space. For example, historical sites and other artefacts cannot be moved spatially in communication, but digital means are enabling this, recording and presenting them in their most original form.

### Providing an Immersive and Interactive Experience of Architectural Cultural Heritage

With the emergence of graphical interfaces and touchscreens, the window of human-computer interaction has become more intuitive, directly bringing people closer to the computer, allowing users to operate by directly clicking on graphics or symbols on the screen through their mobile phones; the emergence of sensors has greatly changed the form of human-computer interaction, allowing users to experience interaction directly through multi-dimensional sensory methods such as hearing, touch and movement with the help of different input devices. Simulation, as in the real world, relies on its own behavioural logic habits to complete the interaction with the virtual world, so that users get a sense of full immersion without interactive interface display. The dissemination of cultural heritage information is transformed from a one-way experience of accessing information only through text and images to a two-way interaction, and from a static communication based on tours to a dynamic communication based on interactive experiences that break the barriers between space and time. Users can interact with virtual things in the virtual reality world, such as virtual tours in architectural and cultural heritage, or virtual operations such as dismantling and modifying buildings, or participating in historical events related to architectural and cultural heritage and interacting with historical figures, in order to achieve an immersive two-way interactive experience. The increased computing power of digital technology and network transmission speeds allow for highly detailed real-time interaction.



### Presenting the Multidimensional Visibility of Architectural Cultural Heritage in Virtual Space

Digital technology can present architectural cultural heritage from a dynamic perspective, expanding the ways in which architectural cultural heritage can be exhibited, reproducing text, pictures, video records and the current situation of its historical trajectory, and sorting out the process of changes in architectural cultural heritage from its birth to the present day (Li, 2021). It is a way of presenting architectural heritage in multiple scales and dimensions, showing the historical development, change processes and information value of architectural heritage. It allows the expression of the objective world and the recreation of past situations, presenting the architectural heritage in a four-dimensional way, interwoven in time and space, in a virtual reality world. This allows the presentation of architectural cultural heritage to move away from a closed conservation space and towards a more diverse and three-dimensional platform. The application of digital technology can complement the shortcomings of traditional architectural and cultural heritage conservation methods, but more importantly, we should use digital technology to complete the preservation and dissemination of historical information and cultural connotations related to architectural and cultural heritage (Guo, 2008).

### Achieving Permanent Preservation and Resource Sharing of Architectural Cultural Heritage

The rapid development and popularisation of digital technology have fundamentally changed the concept and method of conservation of architectural cultural heritage in the traditional sense. Digital technology can easily modify, edit, delete, back up and reproduce the information of architectural cultural heritage, which can accurately record the original data of a specific historical era and achieve the permanent preservation of architectural cultural heritage from environmental erosion and natural disasters. The information presentation of the built cultural heritage is made possible by the use of digital data. The informationised presentation of architectural and cultural heritage extends the breadth and depth of the dissemination of information on the history of cultural heritage through the communication characteristics of digital media, allowing information on architectural and cultural heritage from different countries and regions to be shared within a short period of time, and as long as one has a network terminal device, one can share architectural and cultural heritage regardless of location or time.

### DESIGN METHODS AND PRACTICES FOR DIGITAL ARCHITECTURAL CULTURAL HERITAGE

With the continuous updating and iteration of digital technology, many high-tech means have been widely applied in the field of architectural cultural heritage conservation (Allen *et al.*, 2003; Liu *et al.*, 2018). With the help of various types of technology such as three-dimensional (3D) scanning technology and photogrammetry technology, the information acquisition methods of architectural cultural heritage have been enriched, and the architectural cultural heritage can be recorded and restored completely and accurately (Wang, 2019); virtual reality technology, augmented reality technology and other technologies enrich the presentation and display of architectural cultural heritage; database technology provides data support for permanent preservation of architectural cultural heritage and global information resource sharing.

#### Three-Dimensional Scanning Technology

Three-dimensional (3D) scanning technology combines a variety of high-tech, including optical technology, electrical technology and computer technology, through the scanning of photos, text pages, drawings, samples and other object information into a digital signal (Zhang *et al.*, 2013). The use of 3D scanning technology can quickly obtain the three-dimensional shape, pattern colour, surface albedo and other information of the target object within a short time, and then use the computer system to carry out three-dimensional reconstruction calculations, so as to create the same three-dimensional digital model as the target object (Li *et al.*, 2022). The “digital Michelangelo” project carried out by Stanford University in the United States is a typical case of cultural relics preservation using 3D scanning technology, which opens up the way for the application of 3D scanning technology in cultural heritage protection projects (Levoy *et al.*, 2000).



Source: Baidu pictures.

Figure 4: Notre Dame de Paris modeled in the film.

Three-dimensional (3D) scanning technology is increasingly used in the restoration of architectural cultural heritage (Chiabrando *et al.*, 2016), which can be repaired and restored by 3D scanning technology for those cultural heritage that no longer intact or have disappeared. 3D scanning technology is mainly used to realistically record and preserve the data information of architectural cultural heritage, and provide data and models to support the repair and restoration of architectural cultural heritage (Figure 4). Technical integration of 3D technology with high-definition image data, LiDAR remote sensing technology, Remake, PMVS algorithm and other technologies can improve the accuracy of 3D scanning. Typical examples include the restoration of Dunhuang Mogao Grottoes and morphological restoration of the main statue of Thousand-handed Avalokitesvara carved in Dazu stone in Chongqing. In addition, BIM (Building Information Modelling) based on 3D technology has also attracted considerable attention in recent years (Li *et al.*, 2021)., high-precision BIM models (Biagini *et al.*, 2016). can be used for repair works in a virtual environment (Meng *et al.*, 2019). This technology was used for the physical and virtual restoration of ancient buildings such as Gulangyu Island, Ji'nan governor Town God's Temple, and the 44th Grotto of Maiji Mountain Grottoes (Zhou, 2016; Wu *et al.*, 2016).

### High-Precision Digital Photogrammetry Technology

High-precision digital photogrammetry technology is a commonly used means of collection and recording, which plays a vital role in the protection of architectural heritage. Digital photogrammetry is to convert the acquired optical images of architectural heritage into digital signals through photoelectric sensors, and finally form digital images (Fabio, 2011). In short, it is a modeling technology that digitizes the scene, records the physical scene with two-dimensional photos, and converts it into a three-dimensional model. The first step is to take multi-angle photographs of the building in an evenly and softly lit scene. This is to provide choice for adding various light conditions in the later stage (Croce *et al.*, 2021). It is important to Shoot layer by layer in extreme detail to avoid missing any angle , and ensure that there is more than 70% overlap between photos. After that, complete the intelligent modeling through a series of software.



Source: Baidu pictures.

Figure 5: Real scene and photogrammetric version of Laojun Mountain.



Source: Baidu pictures.

Figure 6: Real scene and photogrammetric version of Wudang Mountain.

The data information in the shooting process can be directly stored in digital format to form high-precision audio and video materials, which is convenient for post-editing and processing, while offering the advantages of higher accuracy, lower cost, and longer storage time.

In 2020, the project team spent 30 days to take a total of more than 10,000 photos using photogrammetry technology and drones to build the centimetre-accurate model of Laojun Mountain (Figure 5) and Wudang Mountain (Figure 6), which mainly recorded the buildings and surrounding scenes.

### Reality Technology

Virtual reality technology (VR), is the use of digital image processing, computer graphics, multimedia technology, sensor technology and other technologies to generate an interactive and dynamic three-dimensional effects virtual world by computers (LIN, 2017). Users only need to wear virtual reality image display devices (such as light-valve glasses, 3D projectors and helmet displays, etc.) to get an "immersive" experience of visual, auditory and tactile, as if they were in the real world. Virtual Reality (VR) technology has matured considerably since its inception, emphasizing that the user is fully immersed in the extremely realistic information space generated by computers, and can carry out a variety of real actions in the computer's virtual environment. VR technology has Multi-Sensory, Immersion, Interactivity and Imagination, which makes it suitable for the protection of architectural cultural heritage.

Augmented reality technology (AR) is a digital technology developed on the basis of VR technology. Augmented reality technology differs from virtual reality technology, in that can see the virtual objects as well as real external scenes. In a study by the Battelle Institute, augmented reality is the 10th most strategic technology trend in 2020. Augmented reality technology is to superimpose the virtual information constructed by computer technology with the real environment and real scene in real life, so that it exists in the same screen or space at the same time, which not only shows the information of the real world, but also displays the virtual information simultaneously. The two types of information complement and superimpose with each other, which gives the audience a sensory realism and thus achieves the sensory experience of transcending reality.

A number of digital protection projects of architectural heritage based on reality technology have been carried out both at domestic and abroad (Osello *et al.*, 2018).

The "digital Dunhuang" project integrates cultural protection, cultural education and cultural tourism. As an art treasure of ancient Chinese civilization, Dunhuang Grottoes are not only a model of Buddhist art, but also an important witness to the development of Chinese art over the centuries. Due to the long history of Dunhuang Grottoes, the relatively poor geographical environment and the increasing number of tourists, which make the visiting experience less enjoyable. Facing the dual influence of natural factors and human factors, in the 1980s, Dunhuang Academy proposed the idea of "Digital Dunhuang", with the aim of achieving the permanent preservation and sustainable utilization of Dunhuang Grottoes. Digital technology is used to obtain all-round digital resources of the cultural relics collection and buildings, and to provide visitors with digital presentation methods to meet a variety of individual needs.

The research group led by Professor Li Deren of Wuhan University utilizes mapping and remote sensing technology to replicate the shape and sculptures of Mogao Grottoes, and all other cultural relics with millimeter precision (Figure 7). So far, the research team has collected mural information from more than 90 caves and established a "digital Dunhuang" database.



Source: Baidu pictures.

Figure 7: Digital collection work site at Mogao Grottoes.



In 2016, the “digital Dunhuang” resource library was launched, opening the high-definition digital images and virtual roaming experience content of 30 classic caves to the public for the first time (Figure 8), breaking the boundaries of time and space. With a variety of high-tech digital technologies such as virtual reality technology, it created an immersive virtual experience with rich sensory feedback for the audience, which can meet the viewing needs of the public even when some grottoes are closed and renovated. With the use of various digital technologies, the cultural and historical background of Dunhuang Grottoes is artistically expressed in a visually creative manner and vividly presented to the public, giving a new interpretation and artistic value to the architectural cultural heritage of Dunhuang Grottoes.

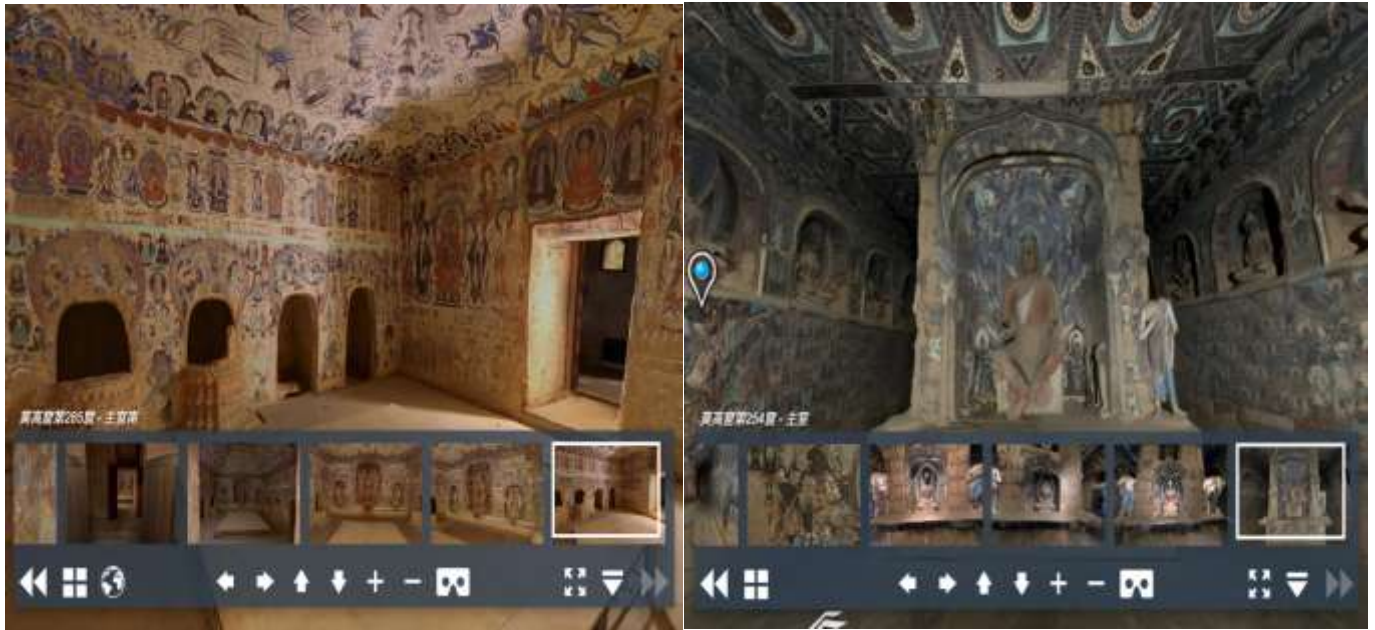

Source: Baidu pictures.

Figure 8: Digital Mogao Grottoes.

The Palace of Versailles today is very different from that of Louis XIV, with most of the buildings no longer standing. In 2019, Google and the Palace of Versailles collaborated to digitally recreate some of the buildings and artefacts of the Palace of Versailles (Figure 9) from the reign of Louis XIV using virtual reality technology (Murphy *et al.*, 2013), and jointly released the VR app “Versailles VR: The Palace is Yours” (Figure 10), which allows visitors to explore Louis XIV Versailles in an immersive way through virtual reality technology, viewing the architecture, decorations, sculptures and paintings in the digitally recreated Palace of Versailles. The launch of the app brings the public closer to Versailles and provides a new channel for the art exhibition at the Palace of Versailles (Maurice *et al.*, 2009).



Source: Baidu pictures.

Figure 9: Digital recreate the buildings and artefacts of the Palace of Versailles.



Source: Baidu pictures.

Figure 10: VR app “Versailles VR: The Palace is Yours”.

### Database Technology

Achieving the digital protection of architectural heritage and establishing digital asset archives is an arduous task, which needs to be supported by strong underlying metadata. As the architectural heritage itself covers a wide area and has a large number of buildings, the information resources acquired in the digital protection work are also extremely large. Firstly, the relevant information of architectural heritage should be digitally collected with the help of digital technology, then use the collected model data, text information, picture information, image information, etc. as the original data for orderly processing, classification and storage, and finally establish the corresponding database system. Artificial intelligence technology, big data, digital twin technology, multi-source detection technology, and blockchain are advanced technologies and intelligent transformations for the digital protection of architectural heritage, which exploring conceptual or feasible technical solutions for the construction of architectural heritage resource database; providing data support for the permanent preservation of architectural heritage that is difficult to protect and easy to damage. This is conducive to the subsequent viewing, application, management and protection of relevant information resources, and more convenient to share information resources on a global scale, that jointly promote the smooth development of digital protection of architectural heritage.

### CONCLUSIONS

The core value of digital technology applied to the preservation of architectural cultural heritage is to be able to provide virtual digital content information of great value and significance to those experiencing it in a realistic real-world environment.

The effective combination of digital technology with the development and utilization of architectural cultural heritage, which changes the original linear way of dissemination of architectural cultural heritage, realizes the resource sharing through the digital resource base, experiences the inculcation of architectural cultural heritage across the distance gap, and at the same time, facilitates the use of the researchers to improve the efficiency of the work, and saves the cost of the research (Zhou *et al.*, 2011). Therefore, the formation of a set of digital strategies and methods for protecting architectural cultural heritage can fully highlight and play a complementary relationship between the advantages of the two, can promote the effective interpretation, display and dissemination of architectural cultural heritage, and ultimately achieve the digital utilization and protection of architectural cultural heritage, which has good economic and social value, with a view to provide certain theoretical reference for the current research and development of the field of digital preservation of architectural cultural heritage.

### ACKNOWLEDGMENT

This work is partially supported by 2020SJA0450 of Philosophy and Social Science Research in Colleges and Universities of Jiangsu Province, China. And it is also partially supported by JXJS2023032 of Teaching Reform and Construction Project Fund of Nanjing Institute of Technology, China. And it is also partially sponsored by Qing Lan Project of Jiangsu Province, China.

### REFERENCES

- Ma, L., Wang, Y. Z., Wang, X. F., Li, Q., & Yuan, P. J. (2020). Research on digital protection and dissemination technology of Dingzhou Confucian Temple. *2020 International Conference on Culture-oriented Science & Technology (ICCST)*, Beijing, China, October 28-31. <https://doi.org/10.1109/ICCST50977.2020.00084>
- Chiabrando, F., Sammartano, G., & Spanò, A. (2016). Historical buildings models and their handling via 3D survey: from points clouds to user-oriented HBIM. *ISPRS-International Archives of the Photogrammetry, Remote Sensing and Spatial Information Sciences, XLI-B5*, 633-640.
- LIN, Y. C. (2017). Application of integration of HBIM and VR technology to 3D immersive digital management: take han type traditional architecture as an example. *ISPRS-International Archives of the Photogrammetry, Remote Sensing and Spatial Information Sciences, XLII-2/W5*, 443-446.



- Zhao, B. B., & Zhao, P. (2018). Digital protection strategy of architectural cultural heritage—Case study of Fengguo Temple. *Architecture & Culture*, 000(005), 70-71.
- Murphy, M., Eugene, M. G., & Pavia, S. (2013). Historic building information modelling-adding intelligence to laser and image based surveys of European classical architecture. *Isprs Journal of Photogrammetry and Remote Sensing*, 76, 89-102. <https://doi.org/10.1016/j.isprsjprs.2012.11.006>
- Li, S. (2021). Inheritance and protection of architectural cultural heritage using digital media technology: Taking the arcade building of Wuzhouxinxi Hotel as an example. *Journal of Wu Zhou University*, 31(3), 51-59. [https://doi.org/10.1673-8535\(2021\)03-0051-09](https://doi.org/10.1673-8535(2021)03-0051-09)
- Nathaniel, L. (2009). *Economics in Urban Conservation*. Cambridge University Press, London.
- Meng, H., Li, Y., & Zhang, Y. (2019). Exploration of digital protection of architectural cultural heritage based on BIM+ concept. *Geospatial Information*, 17(3), 20-23. [https://doi.org/10.1672-4623\(2019\)03-0020-04](https://doi.org/10.1672-4623(2019)03-0020-04)
- Maurice, M., Eugene M. G., & Sara, P. (2009). Historic building information modeling (HBIM). *Structural Survey*, 27(4), 311-327. <https://doi.org/10.1108/02630800910985108>
- Zhang, Y. Y., Zhang, Y., & Chen, X.J. (2013). Research on key techniques of 3D laser scanning technology used measuring traditional architecture. *Architectural Journal*, (2), 29-33. <https://doi.org/CNKI:SUN:JZXB.0.2013-S2-006>
- Croce, V., Caroti, G., Luca, L. D., Jacquot, K., & Veron, P. (2021). From the semantic point cloud to heritage-building information modeling: A semiautomatic approach exploiting machine learning. *Remote Sensing*, 13(3), 461. <https://doi.org/10.3390/rs13030461>
- Fabio, R. (2011). Heritage recording and 3D modeling with photogrammetry and 3D scanning. *Remote Sensing*, V3(6). <https://doi.org/10.3390/rs3061104>
- Levoy, M., Pulli, K., Curless, B., Rusinkiewicz, S., Koller, D., Pereira, L.,... & Ginzton, M. (2000). The digital michelangelo project: 3D scanning of large statues. *International Conference on Computer Graphics and Interactive Techniques (SIGGRAPH'00)*, New Orleans.
- Li, A. R., Deng, W. B., & Hou, X. Q. (2022). Application of 3D laser scanning technology in ancient building surveying and mapping. *Geospatial Information*, 20(7), 101-103. [https://doi.org/10.1672-4623\(2022\)07-0101-03](https://doi.org/10.1672-4623(2022)07-0101-03)
- Feng, N. E. (2017). The idea and practice for digitalized museum construction: The case study of the Palace Museum digital community. *Palace Museum Journal*, 189(1), 108-123. <https://doi.org/10.16319/j.cnki.0452-7402.2017.01.008>
- Allen, P. K., Troccoli, A., Smith, B., Murray, S., Stamos, I., & Leordeanu, M. (2003). New methods for digital modeling of historic sites. *IEEE Computer Graphics and Applications*, V23(6), 32-44.
- Wang, Y. Y. (2019). Research on 3D reconstruction and digital protection of ancient architecture cultural heritage based on LiDAR remote sensing (Master dissertation, Shandong Jianzhu University).
- Guo, Y. Z. (2008). Study on Application of Virtual Reality Technology in the Ancient Architecture Restituting. (Master dissertation, Wuhan University of Technology).
- Li, Y., & Guo, J. (2021). Literature review on architectural cultural heritage protection based on the Concept of BIM+. *Urbanism and Architecture*, 18 (411), 157-161. <https://doi.org/10.19892/j.cnki.csjz.2021.34.35>
- Zhou, Q. M., Geng, G. H., & Wu, Z. K. (2011). *Digital Preservation Technology and Its Applications for Cultural Heritage*. Higher Education Press, Beijing, China.
- Biagini, C., Capone, P., Donato, V., & Facchini, N. (2016). Towards the BIM implementation for historical building restoration sites. *Automation in Construction*, 71, 74-86. <https://doi.org/10.1016/j.autcon.2016.03.003>
- Tong, Q. H., & Wei, W. (2016). Digital protection mode of Macao architectural heritage. *New Architecture*, 6, 39-43. [https://doi.org/1000-3959\(2016\)06-0039-05](https://doi.org/1000-3959(2016)06-0039-05)
- Wu, Z. D., Guo, W. M., & Ai, X. Q. (2016). Digital protection of minority architectural cultural heritage. *Guizhou Ethnic Studies*, 37(4), 84-87. <https://doi.org/10.13965/j.cnki.gzmzyj10026959.2016.04.018>
- Liu, Z. F., Wang, Y., & Huang, D. H. (2018). Application of digital technology and PDA+APPS mobile terminal in historical architecture culture protection and development. *E3S Web of Conferences*, 38, 03004. <https://doi.org/10.1051/e3sconf/20183803004>
- Osello, A., Lucibello, G., & Morgagni, F. (2018). HBIM and virtual tools: A new chance to preserve architectural heritage. *Buildings*, 8(1), 12. <https://doi.org/10.3390/buildings8010012>
- Murphy, M., Pavia, S., & Cahill, J. (2019). An initial design framework for virtual historic Dublin (pp. 901-907). *2nd International Conference of Geomatics and Restoration*.
- Zhou, S. J. (2016). Yungang Grottoes cultural heritage protection which based on the digitization concept and methods. *Journal of Shanxi Normal University Natural Science Edition*, 30 (2), 108-111. <https://doi.org/10.16207/j.cnki.1009-4490.2016.02.022>
- Wang, C. D., & Han, D. C. (2023). Research on the protection and inheritance of intangible cultural heritage from the perspective of digitalization. *Journal of HarBin University*, 44 (3), 115-118. <https://doi.org/10.3969/j.issn.1004-5856.2023.03.026>

## The Design of Agricultural UAV System Based on Kano-AHP-QFD

Shengzan Yan<sup>1,4,\*</sup>

Jun Wang<sup>2</sup>

Guodong Liang<sup>3</sup>

\*Corresponding author

<sup>1</sup> Associate professor, Nanjing Institute of Technology, Nanjing, China, shengzanyan@njit.edu.cn

<sup>2</sup> Student, Nanjing Institute of Technology, Nanjing, China, hebeiysz@163.com

<sup>3</sup> Student, Nanjing Institute of Technology, Nanjing, China, 158823277@qq.com

<sup>4</sup> Visiting scholar, Southeast University, Nanjing, China, shengzanyan@njit.edu.cn

### ABSTRACT

The user requisites for the agricultural UAV system are meticulously examined and dissected. These requirements are then translated into distinct design elements and benchmarks for quality. This process paves the way for an innovative formulation of these products. Leveraging the Kano model, the specific user requisites for the agricultural UAV system are delineated across diverse application scenarios, thus laying the foundation for an overarching demand framework. Through the utilization of the Analytic Hierarchy Process (AHP), the demand framework is subjected to comprehensive analysis, culminating in the establishment of a hierarchical structure that imparts varying weights to each demand facet. Drawing from the principles of the Quality Function Deployment (QFD) theory, a robust correlation between user requirements and quality attributes is constructed, giving rise to the framework known as the QFD house of quality. The conceptual blueprint of the agricultural UAV system is sculpted through an inventive and divergent approach. By rigorously adhering to high levels of precision and objectivity, the user demand framework and QFD house of quality are meticulously crafted. This lays the groundwork for the creation of a pragmatic and inventive design proposal. The seamless integration of the Kano, AHP, and QFD methodologies engenders a more scientifically rigorous exploration of user needs, thereby pinpointing areas requiring refinement. The agricultural UAV system, conceived through this comprehensive approach, serves as a wellspring of novel concepts for intelligent agricultural machinery products and systemic innovation, thereby lending valuable support to agricultural advancement.

*Keywords:* intelligent agriculture, agriculture UAV system, Kano, AHP, QFD, innovative design.

### INTRODUCTION

With the rapid advancement of technologies like the Internet of Things, big data, and artificial intelligence, global agricultural robot research has surged (Tsouros *et al.*, 2019). Currently, agricultural robot research is in a phase of accelerated development, evolving into a versatile and intelligent autonomous unmanned system (Yang *et al.*, 2022). The unmanned aerial vehicle (UAV), serving as a flexible and efficient tool for agricultural information gathering and auxiliary operations, has found extensive utility in recent years in both agricultural production and scientific investigations (Radoglou-Grammatikis *et al.*, 2020). In the era of digital agriculture, UAVs have emerged as pivotal instruments for driving agricultural digitization. Their role remains dynamic, with a progressively expanding array of applications. The significance of UAVs in agriculture lies in their ability to facilitate precision field management and provide swift responses to sudden pests and diseases, thus minimizing losses. The integration of UAVs aligns seamlessly with the principles of precision and smart agriculture, propelling their swift integration into the agricultural domain. The spectrum of applications includes crop pollination, spraying, monitoring, topping and pruning, flower and fruit thinning, and livestock tracking. The autonomy level of these systems holds undeniable importance (Fahlstrom *et al.*, 2022). Yet, despite their evident advantages, there remain certain shortcomings in the agricultural UAV deployment. Enhancements are still required to elevate the operational efficiency and intelligence of these systems (Delavarpour *et al.*, 2021).

Hence, building upon a comprehensive examination of the current state of the agricultural UAV market, this paper will conduct an in-depth analysis of the pivotal factors influencing UAV operational efficiency and intelligence. It will elucidate the requisite design criteria and trajectories, presenting a holistic approach that amalgamates the Kano model, AHP analytic hierarchy process, and QFD quality function deployment. The paper will embark on an innovative redesign of the agricultural UAV system, aimed at addressing the existing deficiencies in agricultural UAV products to a significant extent. This endeavor will serve as a guiding beacon, shedding light on advancing UAV applications in agricultural production while concurrently enhancing the prowess of intelligent operations.

### AGRICULTURAL UAV SYSTEM DESIGN RESEARCH PROCESS

The impetus behind the innovative design of agricultural UAV systems stems from existing issues and user demands, which resonate throughout application sites and among users of various levels. The crux of achieving an optimally designed agricultural UAV system lies in the meticulous classification, analysis, and translation of these problems and requisites into discernible design elements and benchmarks for quality. As intelligent agriculture gains traction and the notion of precision agriculture evolves, the demand for agricultural UAVs among farmers transcends simplistic functionalities like pesticide spraying or

agricultural monitoring. The landscape now encompasses multifaceted applications such as autonomous environmental perception, obstacle avoidance during flight, self-directed path planning, and automated crop identification. This paradigm shift ushers in elevated expectations for agricultural UAV capabilities. To address this evolving landscape, this paper undertakes the task of organizing user needs and quality benchmarks across multiple scenarios, steering the course of innovative agricultural UAV system design. The comprehensive research process is depicted in Figure 1.

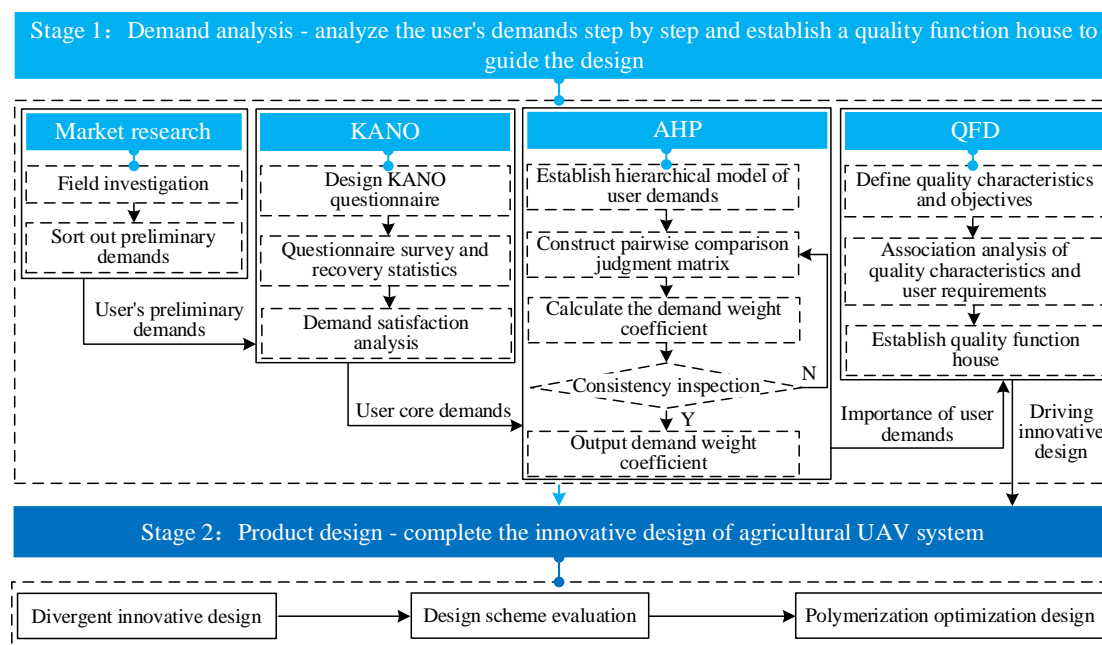

Source: This study.

Figure 1: Agricultural UAV system design and research process.

The design and research process of the agricultural UAV system unfolds in two distinct stages. The initial phase revolves around problem interpretation and needs assessment. Existing challenges and user requisites are systematically scrutinized, culminating in the establishment of a coherent structure called the "house of quality." This structure encompasses demands and priorities, quality attributes and objectives, as well as competitive product analysis. This comprehensive framework serves as the foundation for precise implementation.

The first stage comprises three steps:

1. The application of the Kano model to comprehensively ascertain user needs spanning all dimensions of the agricultural UAV system.
2. Utilizing the Analytic Hierarchy Process (AHP) to dissect multifaceted demands and calculate their respective weights.
3. Leveraging the Quality Function Deployment (QFD) approach to analyze design elements and quality characteristics across various requirements, clarifying quality objectives and establishing a quality function house.

The second stage of the process pertains to function and design implementation. In accordance with the quality function house derived from the first stage, the agricultural UAV system undergoes an innovative design phase, characterized by a divergent approach to innovation.

## RESEARCH ON KEY REQUIREMENTS OF AGRICULTURAL UAV SYSTEM BASED ON KANO

### Kano Model

The Kano model, introduced by Noriaki Kano in 1984 and inspired by Hertzberg's two-factor theory, serves as a method for unearthing demands based on user satisfaction with products or services (Jin et al., 2022). This approach offers foundational insights for subsequent demand exploration (Shi & Peng, 2021). The Kano model bridges the gap between the objectivity of products and the subjectivity of users. It illuminates the correlation between user satisfaction and varying tiers of quality requisites, bearing profound implications for product quality evaluation, user satisfaction assessment, and product design guidance (Yang et al., 2022).

Central to the Kano model's application is the division of user needs into five distinct categories (Lyu et al., 2022):

Must-be (M): Represents indispensable conditions for user contentment.

One-dimensional (O): Pertains to the elevated conditions that fulfill user expectations.

Excitement (E): Embodies conditions that transcend user expectations, adding allure to the product.

Indifferent (I): Constitutes conditions that bear no impact on user satisfaction.

Reverse (R): Denotes conditions leading to adverse outcomes, forming a negative influence.

Among these classifications, "M" signifies essentials, "O" meets user anticipations, and "E" enhances the product's appeal. These factors warrant prime attention during the design phase. Conversely, "I" should be minimized to curb costs, and "R" should be sidestepped to avert unfavorable experiences.

The principal steps in analyzing the agricultural UAV system using the Kano model involve:

1. Developing a Kano questionnaire encompassing positive and negative choices for each demand, in alignment with preliminary requirements identified through literature review.
2. Distributing and collecting filled questionnaires, followed by data collation.
3. Calculating the Better-Worse coefficient, which informs the interpretation of user preferences.
4. Constructing a quartile map to visually represent the demand categories and user preferences.
5. Distilling insights from the analysis to pinpoint design entry points for enhancing user satisfaction.

## Study on the Demand of Agricultural UAV System

### *User analysis and preliminary requirements*

The primary beneficiaries of agricultural UAV systems encompass agricultural enterprises, farmers, agricultural service providers, and governmental regulatory bodies. These stakeholders constitute a diverse spectrum of users, each with distinct requirements and objectives.

Agricultural enterprises emerge as a pivotal user group, relying on UAV systems to execute multifarious tasks such as planting, fertilization, spraying, inspections, and measurements. These operations are geared toward bolstering crop production efficiency and enhancing the overall crop quality.

Farmers, too, stand as potential users of agricultural UAV systems. For them, UAVs offer indispensable support in tasks encompassing planting, fertilization, spraying, and patrolling. This assistance contributes to elevated crop yields and improved produce quality.

Agricultural service providers are also potential users of agricultural UAV systems. They require UAV systems to offer a variety of agricultural services, such as inspections, measurements, and microscopic photography.

Governmental regulators, likewise, emerge as potential adopters of agricultural UAV systems. Their mandate encompasses the monitoring of agricultural production and environmental impact, necessitating UAV systems for oversight and management.

Diversification in user needs mandates that the agricultural UAV system be adaptable and versatile, capable of catering to the varied demands of these stakeholders. Tailoring the system's functionalities and application scenarios to the distinctive requirements of these users serves as a strategic imperative. This flexibility ensures that the system accommodates a wide range of users and maximizes its impact across the agricultural domain.

A comprehensive exploration of the four user categories within the agricultural UAV system was conducted through a combination of field investigations, interviews, and questionnaires. This investigative approach yielded a repository of user demands, forming a comprehensive vocabulary bank. To streamline subsequent analyses, the initial requisites have been labeled sequentially from 1 to 12, as depicted in Table 1.

Table 1: Initial user requirements.

User groups	Vocabulary from the initial survey	Preliminary requirements after affinity graph finishing
Agricultural enterprise	Easy to use, simple operation, suitable for all kinds of weather, safe to use, meet the needs of a variety of operations, stable and reliable, less fault, with other equipment collaborative work, high efficiency, remote control, unmanned...	1-simple operation 2-stable and reliable 3-use safety 4-functional diversity 5-team working 6-efficient work 7-trace record 8-remote control 9-customized service 10-intelligent decision 11-Scene diversity 12-fault reporting
Farmers	Precision spraying, reduce waste, farmland inspection, timely detection of pests and diseases, drought and other issues, provide scientific advice to guide agricultural planting, real-time monitoring of farmland, simple and easy to learn, fast start, stable and less fault, easy maintenance, safety....	
Agricultural service providers	Multi-function, customized services, based on data processing and analysis recommend agricultural services, rapid response, stable and reliable, data security, solve customer problems...	
Governments and regulatory agencies	Work safety, data safety, legal compliance, trajectory tracking, flight records, fault reporting and tracking, with collaborative linkage mechanism...	

Source: This study.

**Kano questionnaire survey**

Guided by product attributes and drawing from pertinent evaluation criteria within the domain of industrial design, a product-specific Kano questionnaire was meticulously devised (Kang & NAGASAWA, 2023). This instrument facilitated the systematic exploration of user requisites, subsequent classification and synthesis of survey findings, and the delineation of Kano attributes for each demand metric inherent to the product.

From diverse user cohorts, a cohort of 39 representatives was thoughtfully selected. Post securing their consent, face-to-face distribution of the questionnaires was executed, ensuring comprehensive data collection. The ensuing statistical results were meticulously tabulated in a classification evaluation table, showcasing a sample evaluation—centered on the attribute of 'simple operation'—as illustrated in Table 2.

Table 2: The classification evaluation form of “easy operation”

'Simple operation' requirements		There are more than 3 operation options for agricultural UAV system.				
		satisfaction	should be so	neutrality	can tolerate	dissatisfied
There are no more than 3 operation options for agricultural UAV system.	satisfaction	suspicious results	E	E	E	O
	should be so	R	I	I	I	M
	neutrality	R	I	I	I	M
	can tolerate	R	I	I	I	M
	dissatisfied	R	R	R	R	suspicious results

Source: This study.

**Better-Worse Coefficient and Quartile Map**

The Better-Worse coefficient encapsulates the selection proportions of M, O, E, I, and R categories for each demand, encompassing two crucial components: the 'satisfaction coefficient  $B_i$ ' and the 'dissatisfaction coefficient  $W_i$ ' (Ishak et al., 2020). As  $B_i$  approaches 1, it signifies an inclination towards intensifying the demand to augment user satisfaction. Conversely, as  $W_i$  approaches -1, it indicates a preference for withholding the demand to forestall a dip in user satisfaction or to address a reverse demand, both of which contribute to an enhanced user experience. To elucidate, let's consider the example of 'simple operation':

$$B_1 = \frac{E_1 + O_1}{E_1 + M_1 + O_1 + I_1} = \frac{5 + 8}{37} = \frac{13}{37} = 0.35 \tag{1}$$

$$W_1 = -1 * \frac{M_1 + O_1}{E_1 + M_1 + O_1 + I_1} = -1 * \frac{16 + 8}{37} = -1 * \frac{24}{37} = -0.65 \tag{2}$$

Upon conducting the requisite calculations, the outcomes encompassing the 'satisfaction coefficient  $B_i$ ', 'dissatisfaction coefficient  $W_i$ ', and the maximum value between  $|B_i|$  and  $|W_i|$  for the initial 12 user requirements are succinctly outlined in Table 3.

Table 3: Preliminary user requirements Better-Worse coefficients.

Item	12 preliminary user requirements											
	1	2	3	4	5	6	7	8	9	10	11	12
Better coefficient ( $B_i$ )	0.35	0.38	0.41	0.57	0.84	0.59	0.86	0.43	0.84	0.42	0.41	0.54
Worse coefficient ( $W_i$ )	-0.65	-0.78	-0.73	-0.70	-0.30	-0.76	-0.27	-0.68	-0.27	-0.39	-0.43	-0.73
max ( $ B_i ,  W_i $ )	0.65	0.78	0.73	0.70	0.84	0.76	0.86	0.68	0.84	0.42	0.43	0.73

Source: This study.

In the table provided,  $B_i$  forms the y-axis coordinate, while  $|W_i|$  constitutes the x-axis coordinate. The median values of  $B_i$  and  $|W_i|$  serve as benchmarks to establish a quartile map, as depicted in Figure 2.

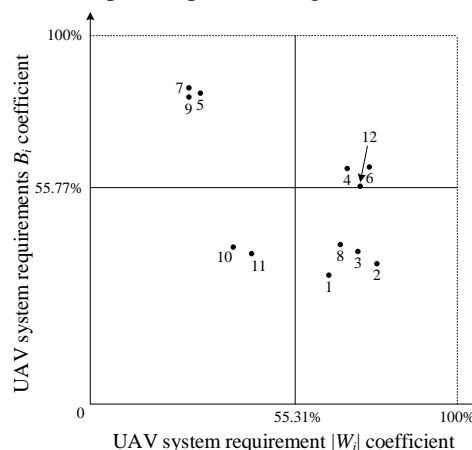

Source: This study.

Figure 2: Preliminary user demand quadrants



From the insights gleaned in Figure 2, it becomes evident that among the initial user requirements, 1, 2, 3, and 8 align with basic requisites, 4, 6, and 12 correspond to anticipated needs, 5, 7, and 9 align with excited expectations, and 10 and 11 are indifferent demands. As a result, the architectural blueprint for the agricultural UAV system should prioritize the augmentation of demands 4, 6, and 12 while ensuring the fulfillment of demands 1, 2, 3, and 8. Subsequently, the focus can shift towards elevating demands 5, 7, and 9.

**DEMAND DEPTH ANALYSIS BASED ON AHP**

**Analytic Hierarchy Method (AHP)**

The Analytic Hierarchy Process (AHP) stands as a quantitative methodology to dissect the significance of diverse factors in intricate problems (Liu et al., 2020). Following the scrutiny facilitated by the Kano model, the application of AHP serves to further elucidate the weightage assigned to user requirements. It addresses the potential limitations in gauging the importance and prioritization of requisites within the Kano model. By doing so, AHP enhances the precision and objectivity of user requirement analysis, furnishing a more precise hierarchical framework for design (Zhou & Wang, 2023).

The primary steps encompassed in the AHP analysis of the agricultural UAV system are as follows:

1. Establishment of the demand hierarchy analysis structure, delineated in consonance with the Kano preliminary user demand quartile map.
2. Construction of pairwise judgment matrices for each sub-factor, in alignment with the hierarchical analysis structure.
3. Calculation of demand weights through the application of a consistency test, resulting in the accurate determination of the importance attributed to both the criterion layer and the index layer within the hierarchical analysis structure (Karasan et al., 2022).

**Hierarchy Analysis of Agricultural UAV System Requirements**

*The establishment of hierarchical model*

Guided by the quartile map of initial user requirements, the hierarchical analysis framework for demands within the agricultural UAV system is meticulously formulated through expert interviews. Refer to Figure 3 for an illustrative representation, comprising the target layer (hierarchical analysis objective), the criterion layer (design principles buttressing the objective), and the index layer (design components essential for achieving the objective).

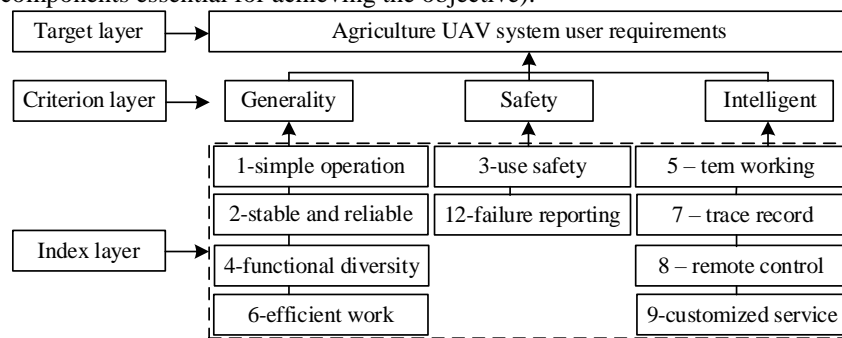

Source: This study.

Figure 3: Agricultural UAV system demand hierarchy

**Construction of judgment matrix**

Employing the 1~9 scale method (Ginting & Ishak, 2020), a quantitative adjacent evaluation index questionnaire was methodically developed, as displayed in Table 4. The evaluation process involved enlisting the expertise of three experts and garnering insights from 46 farmers possessing practical farming experience. This collective group facilitated the execution of pairwise comparison scoring, culminating in the formulation of a comprehensive judgment matrix.

Table 4: 1~9 scaling method

Scale	Requirement <i>i</i> vs. requirement <i>j</i>
1	same important
3	a little more important
5	obviously more important
7	very more important
9	extremely more important
2, 4, 6, 8	intermediate value of adjacent judgment
Inverse of 1~9	When comparing the exchange order of two requirements

Source: This study.

**Weight coefficient calculation**

The weight value corresponding to each index is derived from the eigenvector associated with the maximum eigenvalue within the judgment matrix. Utilizing the square root method, the weight value for the judgment matrix is calculated, thereby

culminating in the comprehensive weight for the hierarchical functional indices within the agricultural UAV system. Let us denote the requirement classification as the correction value "K". For instance, if the requirement category pertains to basic requisites (M), then  $K_M=2$ ; for excited requirements (E),  $K_E=0.5$ ; and for anticipated requirements (O),  $K_O=1$ . To ensure subsequent ease of application, the revised requirement weights undergo normalization, leading to the determination of the ultimate end user requirement weights, as depicted in Table 5.

Table 5: Requirements hierarchy analysis.

	Requirement type	Correction value $K$	Requirement	Initial weight obtained by AHP %	Final weight after correction and normalization with $K$ value %	Requirement importance converted from the final weight
Agriculture UAV system	basic requirement (M)	$K_M=2$	1-simple operation	33.23	44.90	45
			2-stable and reliable	5.40	7.30	7
			3-use safety	2.14	2.89	3
			8-remote control	15.14	20.46	20
	expected requirement (O)	$K_O=1$	4-functional diversity	8.31	5.61	6
			6-efficient work	16.62	11.23	11
			12-fault reporting	3.40	2.30	2
	excited requirement (E)	$K_E=0.5$	5-team working	4.71	1.59	2
			7-trace record	9.00	3.04	3
			9-customized service	2.05	0.69	1

Source: This study.

### Consistency test

The consistency test is executed in accordance with the following formula:

$$CR = \frac{\lambda_{max}-n}{(n-1)*RI} \quad (3)$$

Where  $\lambda_{max}$  represents the maximum eigenvalue of the judgment matrix,  $n$  corresponds to the matrix order,  $RI$  symbolizes the average random consistency index,  $CR < 0.1$  indicates successful completion of the consistency test.

For the criterion layer's judgment matrix, the calculated  $\lambda_{max}$  stands at 3.0037. In accordance with the provided data, the third-order matrix's  $RI$  value is 0.52, resulting in  $CR=0.0035$ . Furthermore, the  $CR$  values for the other judgment matrices are 0, 0.0515, and 0.0303, respectively. This outcome affirms that all matrices have successfully passed the consistency test. Consequently, the analytical data is minimally influenced by the subjective inclinations of the respondents, thereby validating the efficacy of the weight values.

Based on the user requirement weights presented in Table 5, the general weight stands at 58.15%, while the safety and intelligence weights hold at 10.95% and 30.90%, respectively. This insight allows us to infer that users place paramount importance on the operational simplicity and work efficiency of UAVs during their utilization.

## DESIGN OF AGRICULTURAL UAV SYSTEM BASED ON QFD

### Quality Function Deployment (QFD)

Quality Function Deployment (QFD) is a methodology that translates design components and weights into quality characteristic elements and interrelationships. Following the Analytic Hierarchy Process (AHP), the application of Quality Function Deployment serves to illuminate the intricate nexus between design elements and quality characteristic elements. It offers precise technical underpinnings and constraint guidelines for product design, ultimately supplying evaluation criteria for the optimization of design schemes (Ginting et al., 2020; Mistarihi et al., 2020).

To seamlessly transition from user demand quality to design quality elements, culminating in the determination of design weights, the principal outcome of QFD analysis for the agricultural UAV system materializes as the quality function house model. This model consists of distinctive facets:

Left Wall: Comprising user demands or design elements and their respective importance.

Ceiling: Encompassing quality characteristics or technical requisites.

Roof: Reflecting the interrelationships among quality characteristics or technical prerequisites.

Room: Representing the associations between quality characteristic or technical requirement elements and user demands or design components.

Right Wall: Evaluating the most competitive products existing in the market.

Basement: Focusing on quality characteristics and technical standards.

This comprehensive model encapsulates the intricate interplay between user needs, design attributes, and technical requirements, thus guiding the multifaceted design process of the agricultural UAV system.

### Building QFD House of Quality

Based on the outcomes of the demand hierarchy analysis, represented in Table 5, user requirements and their respective importance compose the left wall. To facilitate the quantitative analysis of quality factors, the corrected and normalized final weight, adjusted by the *K* value, is multiplied by 100 and rounded (refer to Table 5 for details). The quality characteristics of the agricultural UAV system, acquired through expert interviews involving a representative from an agricultural UAV production enterprise, an experienced agricultural UAV designer from a design unit, and a farmer engaged in large-scale planting, constitute the ceiling.

The interrelationship analysis among the ceiling's elements is depicted as the roof (utilizing the correlation symbols outlined in Table 6). Concurrently, the interplay between the elements enumerated in the ceiling and the requisites delineated in the left wall is represented as the room (utilizing the correlation symbols in Table 6). For the right wall, competitive product evaluations gauge the user requirements delineated in the left wall. These evaluations utilize the importance value as the full score of the assessment standard. A comprehensive evaluation entails the participation of the aforementioned 46 representative users and 3 experts. The weighted average of these evaluations shapes the competitive product assessment.

Erected upon the quality characteristic objective, the Quality Function Deployment (QFD) quality house model of the agricultural UAV system takes form, as exhibited in Figure 4. This multifaceted model captures the intricate interplay of user demands, design attributes, and quality requirements, thus furnishing a comprehensive blueprint for the agricultural UAV system's advancement.

Table 6: Correlation analysis symbols.

Interactive strength	Symbols	Meaning
9	★	very strong correlation
7	※	strong correlation
5	▲	related
3	◎	weak correlation
1	●	very weak correlation
0	○	un-correlation

Source: This study.

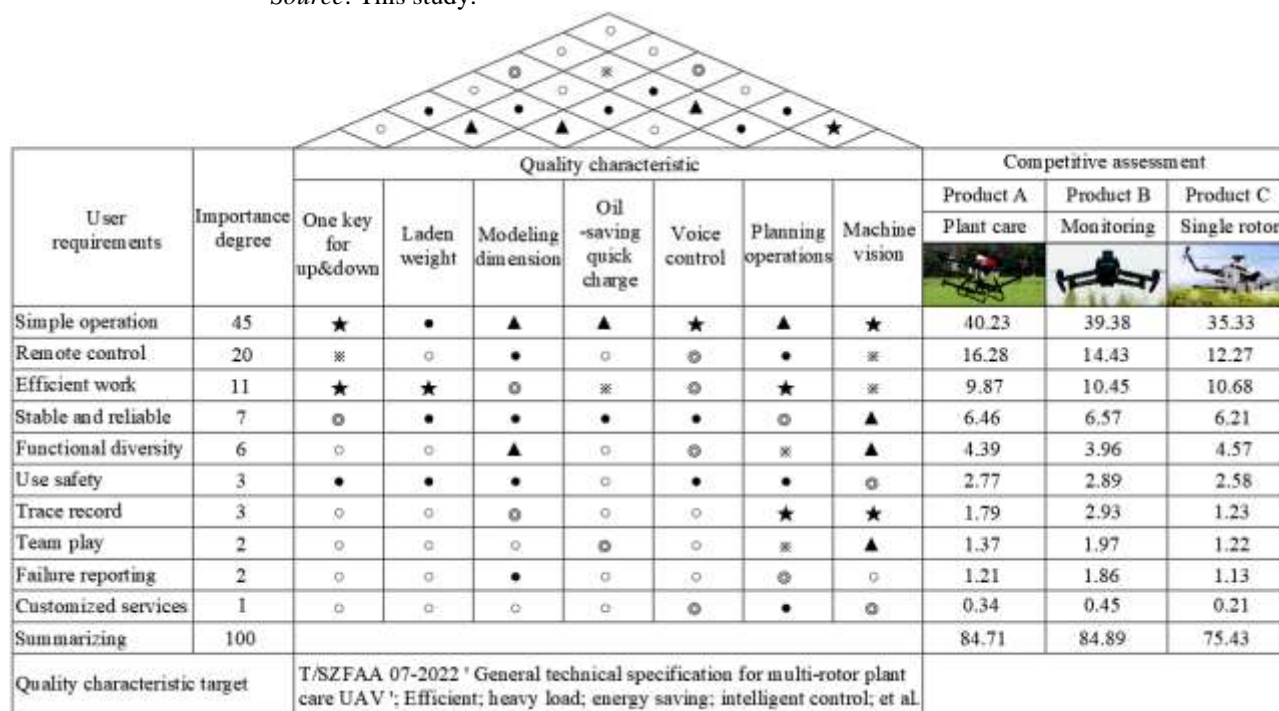

Source: This study.

Figure 4: Agricultural UAV system quality function configuration house

### System Design Scheme

In light of the exploration into the integrated Kano-AHP-QFD method for agricultural UAV systems, the design scheme derived from practical implementation primarily hinges on positioning user requirements, quantifying user demand weights, prioritizing the relative weights of quality characteristics, and dissecting existing product-associated evaluation data and quality characteristic deficiencies. This comprehensive process culminates in the formulation of a design concept, as illustrated in Figure 5, ultimately leading to the culmination of the agricultural UAV system design scheme, presented in Figure 6.

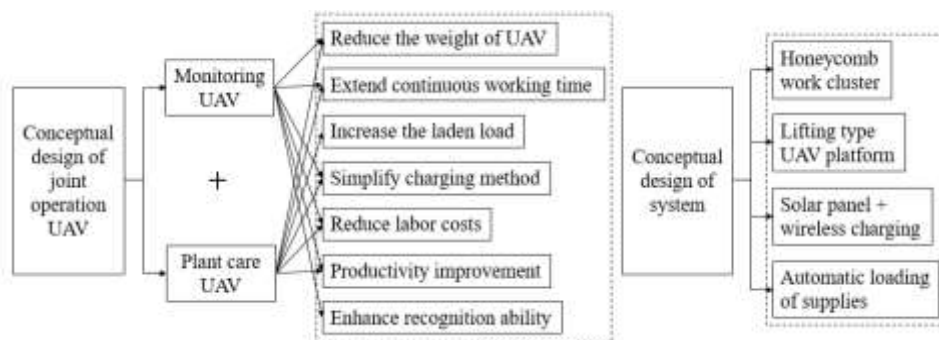

Source: This study.

Figure 5: Propose of design concept

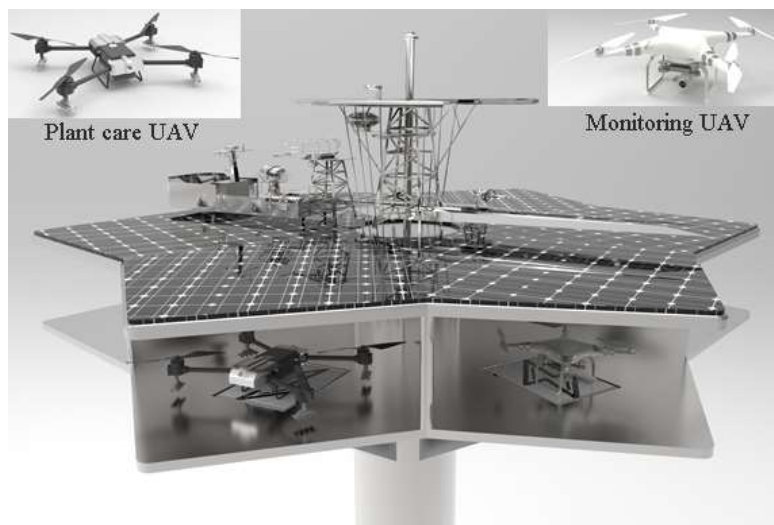

Source: This study.

Figure 6: Agricultural UAV system

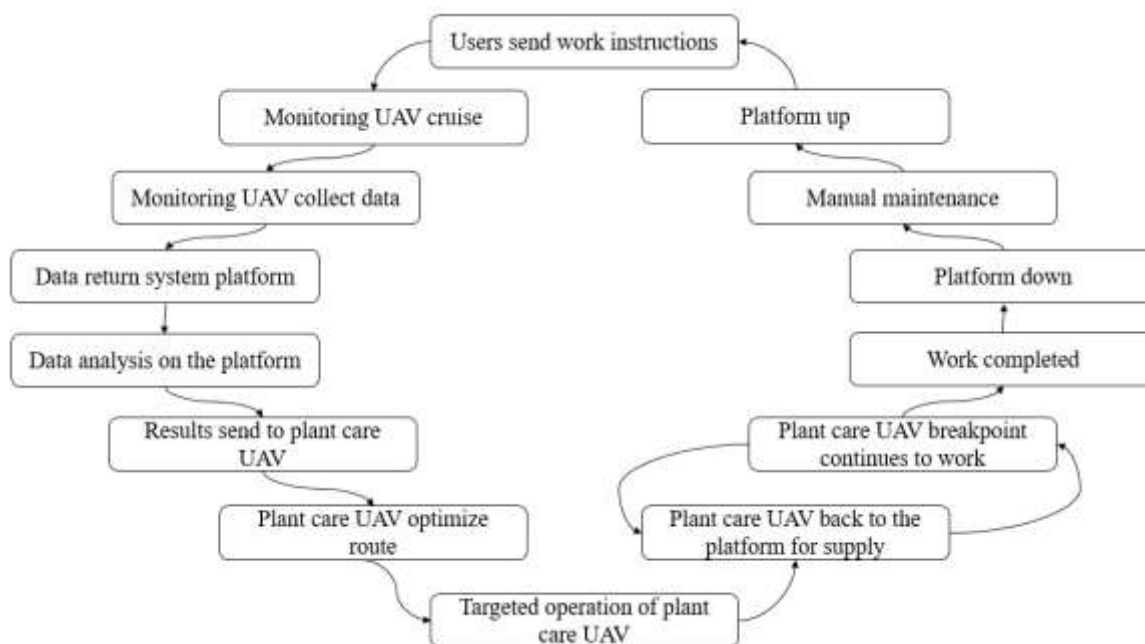

Source: This study.

Figure 7: Agricultural UAV system working process

In the functional design, the requirement of "1 - simple operation" constitutes a fundamental user expectation. Through design optimization, the charging methodology can be simplified, the fuselage weight can be reduced, and the technical complexity of



operation can be minimized. These measures collectively enhance user satisfaction. Streamlining the operation for simplicity and intelligence can notably elevate the user's overall experience.

On the other hand, the requirements of "4 - functional diversity," "6 - efficient work," and "12 - fault reporting" signify anticipated demands. During the design phase, enriching the system's capabilities can be achieved through the joint operation of monitoring UAVs and plant care UAVs. The system's robustness can be amplified via the introduction of a honeycomb work cluster platform. Elevating the efficiency of various UAV models can be achieved by mitigating fuselage weight, extending continuous operational duration, augmenting payload capacity, and enhancing recognition capabilities. This multifaceted design approach substantially heightens user satisfaction. Furthermore, the incorporation of multi-machine cluster operations can adeptly cater to the diverse operational requisites of users.

The conceptualization of the lifting UAV platform holds dual benefits: it not only furnishes a designated parking area for UAVs but also leverages the solar panel atop the platform for energy conservation. The inclusion of a wireless charging mechanism at the berth streamlines the charging process, thereby enhancing operational efficiency to a certain degree. Augmenting this functionality, the presence of a signal base station on the platform facilitates precise real-time transmission of control signals, ensuring stable and consistent remote control operation. By means of centralized management, the collaborative operational capacity is optimized, paving the way for the automatic replenishment of materials for plant protection UAVs. These design elements notably address specific user expectations for enhanced functionality.

The orchestration of this platform, alongside the cluster of drones, is elegantly depicted in Figure 7, providing a visual representation of the operational workflow.

### CONCLUSION

This study delves into the synergistic application of Kano, AHP, and QFD for the innovative design of agricultural UAV systems. This integrated approach proves efficacious on multiple fronts. Firstly, it adeptly uncovers user requirements and encapsulates pivotal elements, thereby charting a clear trajectory for the innovative design of agricultural UAV systems. Secondly, by delving into user requirements analysis, followed by an in-depth exploration of design elements and quality attributes, the design process gains heightened efficiency and rationality.

The incorporation of the Kano model initiates the preliminary filtration of user demands. The AHP method transforms expert judgment data into quantified weight values for design components, thereby conducting a quantitative analysis of user requirements and mitigating the subjective factor's impact on user demand assessment. Through the QFD methodology, ranging from the analysis of design components to quality attributes, the comprehensive evaluation facilitated by the house of quality systematically assimilates existing product data and quality objectives, aligning coherently with established design principles.

While the amalgamation methodology showcased herein pertains to agricultural UAV systems, its universal principles make it applicable as a viable solution for addressing design challenges across a spectrum of other product developments.

### ACKNOWLEDGEMENT

This work was sponsored by the Nanjing Institute of Technology university-level scientific research innovation fund project (CKJB202211), Major project of Philosophy and Social Science research in colleges and universities of Jiangsu Province (2023SJZD108), Provincial innovation training program for College Students (20221127646Z), Ministry of Education Human Society project of China (22YJC760024), and sponsored by 2023 Qing Lan Project.

### REFERENCES

- Delavarpour, N., Koparan, C., Nowatzki, J., Bajwa, S., & Sun, X. (2021). A technical study on UAV characteristics for precision agriculture applications and associated practical challenges. *Remote Sensing*, 13(6), 1204. <https://doi.org/10.3390/rs13061204>
- Fahlstrom, P. G., Gleason, T. J., & Sadraey, M. H. (2022). *Introduction to UAV systems*. Fifth edition. Hoboken, NJ: John Wiley & Sons, Ltd.
- Ginting, R., & Ishak, A. (2020). An Integrated of AHP–QFD Methodology For Product Design: A Review. *Jurnal Ilmiah Teknik Industri*, 8(1). <https://doi.org/10.24912/jitiuntar.v8i1.6901>
- Ginting, R., Ishak, A., Malik, A. F., & Satrio, M. R. (2020). Product development with quality function deployment (QFD): a literature review. In *IOP Conference Series: Materials Science and Engineering* (Vol. 1003, No. 1, p. 012022). IOP Publishing. <https://doi.org/10.1088/1757-899X/1003/1/012022>
- Ishak, A., Ginting, R., Suwandira, B., & Malik, A. F. (2020). Integration of kano model and quality function deployment (QFD) to improve product quality: a literature review. In *IOP Conference Series: Materials Science and Engineering* (Vol.1003, No.1, p.012-025). IOP Publishing. <https://doi.org/10.1088/1757-899X/1003/1/012025>
- Jin, J., Jia, D., & Chen, K. (2022). Mining online reviews with a Kansei-integrated Kano model for innovative product design. *International Journal of Production Research*, 60(22), 6708-6727. <https://doi.org/10.1080/00207543.2021.1949641>
- Kang, X., & NAGASAWA, S. Y. (2023). Integrating continuous fuzzy Kano model and fuzzy quality function deployment to the sustainable design of hybrid electric vehicle. *Journal of Advanced Mechanical Design, Systems, and Manufacturing*, 17(2), JAMDSM0019. <https://doi.org/10.1299/jamdsm.2023jamdsm0019>

- Karasan, A., Ilbahar, E., Cebi, S., & Kahraman, C. (2022). Customer-oriented product design using an integrated neutrosophic AHP & DEMATEL & QFD methodology. *Applied Soft Computing*, 118, 108445. <https://doi.org/10.1016/j.asoc.2022.108445>
- Liu, Y., Eckert, C. M., & Earl, C. (2020). A review of fuzzy AHP methods for decision-making with subjective judgements. *Expert Systems with Applications*, 161, 113738. <https://doi.org/10.1016/j.eswa.2020.113738>
- Lyu Z.Y., Yang B., & Chen Y. (2022). The design of fruit logistics turnover box based on Kano-AHP-QFD. *Packaging Engineering (Art edition)*, 43(18), 95-103. <https://doi.org/10.19554/j.cnki.1001-3563.2022.18.013> (in Chinese)
- Mistarihi, M. Z., Okour, R. A., & Mumani, A. A. (2020). An integration of a QFD model with Fuzzy-ANP approach for determining the importance weights for engineering characteristics of the proposed wheelchair design. *Applied soft computing*, 90, 106-136. <https://doi.org/10.1016/j.asoc.2020.106136>
- Radoglou-Grammatikis, P., Sarigiannidis, P., Lagkas, T., & Moscholios, I. (2020). A compilation of UAV applications for precision agriculture. *Computer Networks*, 172, 107148. <https://doi.org/10.1016/j.comnet.2020.107148>
- Shi, Y., & Peng, Q. (2021). Enhanced customer requirement classification for product design using big data and improved Kano model. *Advanced Engineering Informatics*, 49, 101340. <https://doi.org/10.1016/j.aei.2021.101340>
- Tsouros, D. C., Bibi, S., & Sarigiannidis, P. G. (2019). A review on UAV-based applications for precision agriculture. *Information*, 10(11), 349. <https://doi.org/10.3390/info10110349>
- Yang, H., Huo, Y., Jia, R., Sha, F., Hu, N., Yu, L., & Wang, Y. (2022). Sustainable Recognition Methods of Modeling Design Features of Light and Micro Vehicle-Mounted UAV: Based on Support Vector Regression and Kano Model. *Sustainability*, 14(13), 8210. <https://doi.org/10.3390/su14138210>
- Yang R., Wang Y.K., Wang B.J. (2022). Progress and trend of agricultural robots based on WoS bibliometrics and knowledge graph. *Transactions of the Chinese Society of Agricultural Engineering (Transactions of the CSAE)*, 38(1), 53-62. <https://doi.org/10.11975/j.issn.1002-6819.2022.01.006> (in Chinese)
- Zhou H.Y., & Wang J.L. (2023). Design of elderly-oriented bathroom products based on Kano-QFD. *Packaging Engineering (Art edition)*, 44(4), 150-157. <https://doi.org/10.19554/j.cnki.1001-3563.2023.04.018> (in Chinese)

Zhang, Zhiyun, Li, Pengyu., & Chen, Yanhong. (2023). The effect of host personality on property performance and review volume: Evidence from an accommodation-sharing platform. In Li, E.Y. *et al.* (Eds.) *Proceedings of The International Conference on Electronic Business, Volume 23* (pp. 629-636). ICEB'23, Chiayi, Taiwan, October 19-23, 2023

## The Effect of Host Personality on Property Performance and Review Volume: Evidence from an Accommodation-Sharing Platform

Zhiyun Zhang <sup>1,\*</sup>  
Pengyu Li <sup>2</sup>  
Yanhong Chen <sup>3</sup>

\*Corresponding author

<sup>1</sup> Harbin Institute of Technology, Harbin, China, PhD candidate, [zzy0059@hit.edu.cn](mailto:zzy0059@hit.edu.cn)

<sup>2</sup> Harbin Institute of Technology, Harbin, China, PhD candidate, [947454669@qq.com](mailto:947454669@qq.com)

<sup>3</sup> Harbin Institute of Technology, Harbin, China, PhD candidate, [chenyanhong@stu.hit.edu.cn](mailto:chenyanhong@stu.hit.edu.cn)

### ABSTRACT

Although numerous studies have investigated the impact of marketer-generated content (MGC) on consumers' booking and review posting behavior in accommodation-sharing platforms, little is known about the effect of the host disclosed personality. This study aims to examine the effect of the host personality on consumers' booking and reviewing behavior on peer-to-peer property rental platforms. Utilizing secondary data from Airbnb, the study sheds light on how hosts' personality influence review volume and property performance. The empirical results showed that host agreeableness and conscientiousness positively influence consumers' review posting behavior; the extraversion of the host has an inverted-U shape influence on consumers' booking behavior and review posting. Moreover, the property quantity can moderate the effect of hosts' personality on review volume and property performance. The results show that providing comprehensive and detailed descriptions related to hosts improves review volume. The findings contribute to both the literature and practice within the sharing economy and tourism industry.

*Keywords:* Accommodation-sharing economy, marketer-generated content, host's personality, purchase behavior, property quantity

### INTRODUCTION

Accommodation-sharing economy services have accelerated market growth in tourism (Liang, Schuckert, Law, & Chen, 2020) and cater to the specialized needs of travelers (Guttentag, 2015). Different from the conventional hotels, every property on the accommodation-sharing economy platform has its own characteristics and every host has a distinct personality. In addition, due to the limited capacity of rental accommodations, the overall volume of guest reviews for each property is still much smaller than the volume for hotels (Tao, Fang, Luo, & Wan, 2022). This drives marketer (host) to generate more information to introduce their products or themselves, that is, marketer-generated content (MGC), to engage potential consumers (Ert, Fleischer, & Magen, 2016; Goh, Heng, & Lin, 2013).

Prior studies found that MGC had great influence on consumers' purchasing behaviors and property performance (Goh et al., 2013). For example, Liang et al. (2020) demonstrated that providing comprehensive and detailed descriptions related to both properties and hosts improves review volume. Moreover, the description of the host in the listings can also reflect their personality, which may be an essential characteristic in consumers' purchase decision process. Since the guests may need help with a smooth check-in, interact with the hosts during their stay and want to feel welcomed and safe, need help in dealing with unexpected incidents during the stay or seek local guides. Therefore, the personality of the host can greatly influence the guests' experience of the travel, further influencing their booking behavior.

Service providers as well as consumers in a sharing economy may choose to provide (Taylor 2018) or consume based on more than just monetary reasons. There is an intimacy associated with an Airbnb stay (Wang, Jiang, Han, & Qiu, 2022). Service providers in the accommodation-sharing economy may behave differently from a salesman in traditional market, highlighting the critical role of host characteristics (e.g., personality). Therefore, the characteristics of service providers (hosts) are more influential to business outcomes and can potentially make their services stand out in the sharing economy. Taken together, the unique features of space-sharing platforms allow consumers to choose their lodging not only by price and material measures, but also by their anticipated host personality, which has a great influence the experience of their accommodation.

On the Airbnb platform, hosts are allowed to introduce themselves through posting textual or graphic information to attract guests (Tao et al., 2022; Wang et al., 2022). For example, hosts can show their unique personality and advantages to increase their popularity and trustworthiness in guests' minds. Beyond objective qualities, such as guest ratings, location, size, and the



amenities of the properties, the characteristics of the hosts in these online descriptions may impact the guests' willingness to book their services (Tao et al., 2022). Although Liang et al. (2020) have found that the description about the host positively influence the guest booking, none of the research examine how the personality of the host influence the guest booking and review posting.

Moreover, on the one hand, property quantity may be considered to be in conflict with economic activity due to scarcity of resources, and on the other hand, because when hosts manage more properties, their experience and knowledge of managing properties increases. How the property quantity of host moderates the effect host disclosed personality on review volume is still unknown.

Therefore, in this study, we aim to address the following research questions:

RQ1: How do the host's personality (agreeableness, conscientiousness, extraversion) embedded in MGC impact the sales of their services on a sharing-accommodation platform?

RQ2: How the property quantity of the host moderates the effect of hosts' personality on review volume?

## LITERATURE REVIEW

### MGC in Accommodation Sharing Economy Platforms

MGC refers to content generated by marketers or sellers to deliver the function, quality, and enjoyment of the products (Li & Hitt, 2008) or the qualification, credibility, and reputation of the sellers (Liang et al., 2020) and to engage consumers on official or third-party social media platforms (Meire, Hewett, Ballings, Kumar, & Van den Poel, 2019). With the popularity of social media platforms such as Facebook, which provide a community in which marketers can communicate with consumers and then introduce and promote their goods or services to consumers (Hassan & Ariño, 2016), more and more attention has been paid to the research on MGC.

In the peer-to-peer accommodation platforms (e.g., Airbnb), the content generated by the host to engage prospective consumers (Ert et al., 2016) can be classified as marketer-generated content (MGC) (Goh et al., 2013). Specifically, P2P accommodation platforms allow the host to generate host description for the guests to read (Ert et al., 2016) as is shown in the figure 1. The host description is a textual description about the host's attributes and a successful host description can help guests know more about the particular features of the host (Liang et al., 2020; Wang et al., 2022).

By reading MGC, consumers can get a better understanding about products because only the sellers have the most complete information about their products or services (Goh et al., 2013). Consumers are willing to pay a premium when more information about the seller is obvious and accessible (Tsai, Egelman, Cranor, & Acquisti, 2011). Previous studies have examined the informative and advertising effects of MGC on guests' purchase decisions (Kumar & Reinartz, 2016). Some studies demonstrated that the host quality attributes, i.e., local host, Superhost, tenure, identity verification et al., significantly influence the guest reservation of the listings (Xie & Mao, 2017). Prior studies also found that the description about the listings attribute, including length and depth (Chung & Sarnikar, 2021; Liang et al., 2020), significantly influence the listing performance. In addition, host descriptions have also been proved a key marketing tool for hosts and can significantly influence listing performance (Liang et al., 2020; Tao et al., 2022). In the study on the impact of host descriptions, researchers found that the host profile, like "well-travelled", "familiar with location", et al., presented in the host descriptions have significantly influence on listing performance (Nieto García, Muñoz-Gallego, Viglia, & González-Benito, 2020; Tussyadiah & Park, 2018). Moreover, studies revealed that the affective expression in host description has an inverted U-shape relationship with the listing performance (Wang et al., 2022).

Although previous research has demonstrated that the importance the description about the host, none of the research has examined how the latent personality in the host description influence guest booking. Thus, in this paper, we further study host descriptions by using text-mining approaches to identify the personality that are present in host descriptions and estimating their impact on guest booking.

### Personality Trait

Personality has been defined as the characteristic set of behavior, emotional characteristics that distinguish an individual from other people (McCrae & John, 1992). Although different taxonomies about personality have been proposed, the Big Five personality theory has strong theoretical and practical implication and has been widely recognized by various disciplines (Baumgartner, 2002). The "Big Five" describes personality using five traits (McCrae & John, 1992). The first trait is agreeableness, which refers to the extent to which an individual is compassionate, cooperative towards others (Adamopoulos, Ghose, & Todri, 2018). The second trait is conscientiousness and captures the extent to which an individual is organized and responsible (Adamopoulos et al., 2018). The third trait is extraversion that refers to a person's tendency to be talkative, assertive, energetic (Adamopoulos et al., 2018). The fourth trait is neuroticism and describes the extent to which an individual is sensitive to psychological distress or anxiety (Adamopoulos et al., 2018). The fifth trait is openness, which refer to the extent to which an individual is imaginative, creative, open-minded (Adamopoulos et al., 2018).

Traditional way of measuring big five personality requires the subject to complete lengthy questionnaires, and it's particularly burdensome to obtain such information on a large scale (Costa Jr & McCrae, 1992). For example, prior research has adopted a

60-item Five Factor Inventory to measure personality of the CEO (Mairesse & Walker, 2006). However, tapping into the recent advances of text processing technology and linguistic theory (Park et al., 2015), the personality can be automatically derived and assessed from text based on the established relationship between word use and personality (Yarkoni, 2010). Previous studies demonstrated the validity of personality traits calculated by the lexicon-based approach (Yarkoni, 2010) and it was more accurate than self-reported personality traits (Mairesse & Walker, 2006).

Previous studies have demonstrated that one's personality can greatly influence other's behavior (Adamopoulos et al., 2018). In Adamopoulos et al. (2018)'s research, they calculate the latent personality traits of online users based on social media information and analyze how personality of social media users influences the purchasing decisions of other consumers. The research found that the degree of personality similarity between two social media users had a positive impact on the likelihood of subsequent purchase from a recipient of the message. In addition, specific pairwise combinations of personality characteristics of senders and recipients of messages.

In this research, we focus on how the personality of the host calculated via host description information influence guest booking behavior. Specifically, three of the Big Five personality traits, namely agreeableness, conscientiousness and extroversion, were considered in our research since several studies have shown that the role of Extraversion and Agreeableness in interaction with others (Norman & Watson, 1976), and the conscientious is high with the performance of the server, while this was not the case for openness. For the neuroticism, one may suggest that negative emotions contained in the host description could also impact sales (Wang et al., 2022). We first theoretically argue that the hosts as marketers in our context, with the goal of selling their listings, will naturally write their descriptions in a non-negative manner, that is less neurotic. Thus, the neuroticism is not considered in our research.

## HYPOTHESIS

### **The Role of Host Agreeableness**

Agreeableness typically correlates with traits such as warm, altruistic and tender-minded, friendly. Studies demonstrated that individuals with high level of agreeableness are driven to sustain desirable relationships with others in their social interactions (Goldberg, 1990). For hosts, those with high agreeableness are more attuned to guest requirements, facilitating enduring, positive customer relationships, thereby augmenting repeat business and profitability (Kim, Shin, & Umbreit, 2007). Moreover, a strong connection has been observed between agreeableness and evaluators' rating of hireability (Kluemper, Rosen, & Mossholder, 2012). Therefore, we propose the following hypothesis

**H1** : Host agreeableness has a positive effect on the guest booking behavior and review posting.

### **The Role of Host Conscientiousness**

The trait of conscientiousness embodies of an individual's proclivity towards responsibility, steadiness, and self-assured, a key predictor of job performance (Goldberg, 1990). Within the hospitality sector, a high degree of conscientiousness is imperative for semi-skilled, skilled roles (Kim et al., 2007). Individuals showing this trait are most actively sought out by recruiters (Kluemper et al., 2012). For hosts, those with high conscientiousness may enhance the trustworthiness of their property and provide a heightened sense of safety for consumers, essentially appealing to more consumers booking and prompting more online reviews. Therefore, we put forward the following hypothesis:

**H2** : Host conscientiousness has a positive effect on the guest booking behavior and review posting.

### **The Role of Host Extraversion**

Extraversion is characterized by traits such as sociability, gregariousness, optimism, and assertiveness (Goldberg, 1990). Individuals leaning towards extraversion typically seek social interaction in the workplace (e.g., Kluemper et al., 2012), thus more likely to approach managers or colleagues. Moreover, Kluemper et al., (2012) theorized that managers have a predilection for confident and extroverted individuals.

However, extraversion also insinuates qualities like being energetic, spontaneous, and adventurous (Goldberg, 1990). While being extraverted often provides benefits in social relations, an overly high presence of this trait might not necessarily result in additional advantages and may potentially harm relationships. For example, excessive extraversion could lead to a struggle in curbing socially inappropriate behaviors or restraining display of overambition, causing others or managers hesitate in fully committing to the relationship. Indeed, individuals showing high levels of extraversion exhibit lower levels of self-control, that is, less capability to manage expressions of socially inappropriate emotions and impulses, and extraverts have been associated with more frequent rule infringements (Zabelina, Robinson, & Anicha, 2007).

Similarly, for hotel staff (e.g., hotel owners), extraverted sociability can also lead to more interaction with or attracts more customers, but beyond a certain level extraversion this effect may be weakened. Therefore, we put forward the following hypothesis:

**H3**: Host extraversion has a nonlinear (inverted U-shaped) relationship with guest booking and review posting behavior.

### The Moderating Effect of Property Quantity

Property quantity are thought to conflict with economic activities due to resource scarcity; this is described as a trade-off in the literature (Liang, Schuckert, Law, & Chen, 2020). In the context of Airbnb, as the host manages more listings, the quality expected for each of these listings decreases. Multiple listings certainly increase total reservations for the host. However, the property quantity can also reflect the profession of the host, since when they manage more listings, their experience and knowledge about managing the property increase. Based on the above arguments derived from host personality and the attribute of the property quantity, we postulate a trade-off hypothesis between host personality and quantity in Airbnb host listings:

H4a: property quantity can (positively/negatively) moderate the relationship between the agreeableness and guests' booking

H4b: property quantity can (positively/negatively) moderate the relationship between the conscientiousness and guests' booking behaviors.

H4c: Property quantity can (positively/negatively) moderate the relationship between host descriptions and guests' booking behaviors.

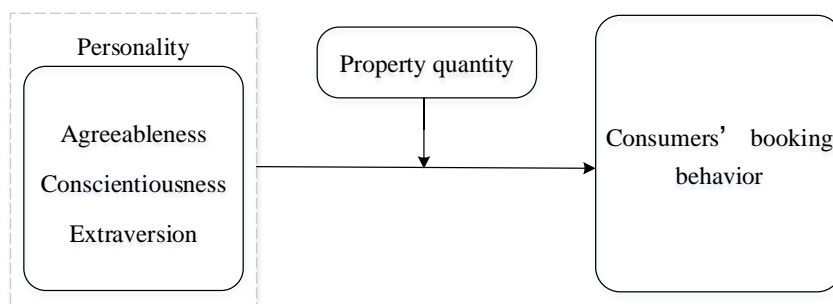

Source: This study

Figure 1: The conceptual framework

## METHODOLOGY

### Data Collection

In this research, we utilized the data on Airbnb listings, one of the largest sharing accommodation platforms, since Airbnb has designed the host can present the text information about themselves, which is suitable for us to calculate the personality of the host. We collect the data from the website InsideAirbnb.com with publicly available information about Airbnb listings. The data consist of various text descriptions and key metrics about listings and hosts. This study selected Austin, Boston, Chicago, Los Angeles, Nashville, New York, San Diego, San Francisco, Seattle, the nine cities, as a destination to investigate and target all accommodations in the nine cities registered on Airbnb. We collect the data on the December 24, 2021. After exclude the listings that the length of the host description is smaller than 50, the final data set include 25832 sample listings.

### Variables

The dependent variable used in this study was the number of reviews (*RevNum*), a proxy for the sales, which can reflect the ability of a property to attract reviews. The Independent variables in this research is the personality of the host. With the help of natural language processing, host personality can be analyzed on the basis of the post descriptions about themselves. We preprocessed host description text data, such as removing stop-words and deleting description text whose word count is less than 50. The method of Adamopoulos et al. (2018) is utilized to impute the host personality. In particular, LIWC is employed to compute linguistic scores, which are denoted as *Score*, in each dictionary category. The weighted coefficients of each dictionary category were obtained, which are denoted as *Weights<sub>i</sub>* (*i* = extra, agree, cons). The product of *Score* and *Weights* is the value of host personality (*Personality*).

The moderating variable in this research is the number of properties for each host (*BookingNum*). Previous research has shown the effects of the host attributes, rating of the listing, and listing attributes on consumer booking behavior. To ensure the robustness of the empirical results, the authors also include some control variables as follows: rooms (*Room*), bathrooms (*Bathroom*), beds (*Bed*) and the number of the amenities (*AmeNum*) in the listings, the review rating (*Rating*) and price (*Price*), accommodate (*Accommodate*) of the listings, whether the host is superhost (*Superhost*), local (*IsLocal*), identity verified, the gender (*Gender*), duration (*Duration*), response rate (*ResRate*), acceptance rate (*AccRate*), response time (*ResTime*) of the host.

Table 1: The statistic description

Variable	Obs	Mean	Std. Dev.	Min	Max
<i>RevNum</i>	25832	62.779	92.715	1	1569
<i>Agree</i>	25832	5.641	1.283	-.036	12.456
<i>Cons</i>	25832	.163	.567	-2.902	2.817
<i>Extra</i>	25832	.66	.721	-2.13	3.79
<i>lnPrice</i>	25832	5.005	.805	2.398	9.21
<i>ListingsNum</i>	25832	.65	.477	0	1
<i>IsLocal</i>	25832	.695	.46	0	1
<i>Superhost</i>	25832	.469	.499	0	1
<i>Room</i>	25832	1.748	1.118	1	14
<i>Bathroom</i>	25832	1.528	.973	0	27.5
<i>Bed</i>	25832	2.394	2.152	0	33
<i>ResRate</i>	25832	.754	.414	0	1
<i>Rating</i>	25832	4.745	.496	0	5
<i>ResTime</i>	25832	1.956	1.25	1	4
<i>IsVerified</i>	25832	.898	.303	0	1
<i>lnDuration</i>	25832	7.68	.559	2.197	8.524
<i>AmeNum</i>	25832	33.14	13.062	1	102
<i>AccRate</i>	25832	.704	.394	0	1
<i>Accommodate</i>	25832	4.241	3.022	1	16

Source: This study

### Empirical Model

The authors constructed Ordinary least squares (OLS) regression models to examine our hypothesis in this study. The specific econometric models are as follows:

$$Booking_{num_{ij}} = \beta_0 + \beta_1 Agree_{ij} + \beta_2 Cons_{ij} + \beta_3 Extra_{ij} + \beta_4 Extra_{ij}^2 + \beta_5 ListingNum_{ij} + \beta_{15} control_{ij} + \varepsilon_{ij} \quad (1)$$

$$Booking\_num_{ij} = \beta_0 + \beta_1 Agree_{ij} + \beta_2 Cons_{ij} + \beta_3 Extra_{ij} + \beta_4 Extra_{ij}^2 + \beta_5 ListingNum_{ij} + \beta_6 IsLocal_{ij} + \beta_7 BookingNum \times Agree_{ij} + \beta_8 ListingNum_{ij} \times Cons_{ij} + \beta_9 ListingNum_{ij} \times Extra + \beta_{10} ListingNum_{ij} \times Extra_{ij}^2 + \beta_{15} control_{ij} + \varepsilon_{ij} \quad (2)$$

### Empirical Results

The empirical results of the ordinary least square are shown in Table 3. Model 1.1 tested the effect of the host personality (i.e., agreeableness, conscientiousness, extraversion) on the reviewer number. Models 1.2-1.5 include the moderating variable were employed to test the moderating effect of listing number of the host. The coefficient of *Agree* (coeff. = 3.275,  $p < 0.01$ ) was significantly positive, suggesting that the more agreeable the host is, the more likely the reviewer was to book rooms and post reviews. H1 was thus supported. The value of  $\beta_2$  (coeff. = 2.089,  $p < 0.1$ ) demonstrated that the host's conscientiousness can also positively influence consumers' booking behavior and posting reviews. Therefore, H2 was supported. Moreover, the symbol of *Extra* and *Extra*<sup>2</sup> were positive and negative (coeff. = 2.515,  $p < 0.05$ ; coeff. = -2.144,  $p < 0.01$ ) respectively: thus, the effect of host extraversion on reviewers' booking behavior and review posting is increasing first and then decrease. H3 were accordingly supported.

Another set of results regards the moderating effect of property quantity on the relationship between the host personality and review volume. The related results are presented in Model 1.3-1.5 in Tables 3. The results reveal that the coefficients of the

interaction terms between agreeableness, extraversion and property quantity are significantly negative, while the coefficients of *ListingsNum*×*Cons* is significantly negative. Therefore, these results support Hypotheses 4a, 4b, and 4c.

Table 2: Empirical results

VARIABLES	Model 1.1	Model 1.2	Model 1.3	Model 1.4	Model 1.5
<i>Agree</i>	3.275***	0.935*	1.848**	0.933*	0.773
<i>Cons</i>	2.089*	2.565**	2.547**	-2.926*	2.514**
<i>Extra</i>	2.515**	4.182***	4.156***	4.258***	7.637***
<i>Extra</i> <sup>2</sup>	-2.144***	-1.759***	-1.737***	-1.711***	0.480
<i>ListingsNum</i>		-14.19***	-5.494	-15.96***	-9.047***
<i>ListingsNum</i> × <i>Agree</i>			-1.527*		
<i>ListingsNum</i> × <i>Cons</i>				8.759***	
<i>ListingsNum</i> × <i>Extra</i>					-5.306***
<i>ListingsNum</i> × <i>Extra</i> <sup>2</sup>					-3.180**
<i>lnPrice</i>		-9.038***	-9.024***	-9.123***	-8.953***
<i>IsLocal</i>		17.80***	17.78***	17.82***	17.83***
<i>Superhost</i>		35.15***	35.16***	34.98***	34.74***
<i>Room</i>		-11.20***	-11.23***	-11.24***	-11.31***
<i>Bathroom</i>		-8.568***	-8.583***	-8.539***	-8.581***
<i>Bed</i>		0.219	0.243	0.188	0.269
<i>ResRate</i>		-28.91***	-28.97***	-28.93***	-28.99***
<i>Rating</i>		6.140***	6.108***	6.069***	6.062***
<i>ResTime</i>		-12.19***	-12.22***	-12.21***	-12.24***
<i>IsVerified</i>		-1.265	-1.270	-1.277	-1.319
<i>Intenture</i>		27.12***	27.12***	27.29***	27.26***
<i>AmeNum</i>		0.00837	0.00690	0.00848	0.000266
<i>AccRate</i>		24.08***	24.00***	24.06***	23.97***
<i>Accommodate</i>		3.924***	3.919***	4.010***	3.954***
City-fixed	No	Yes	Yes	Yes	Yes
Constant	43.58***	-119.6***	-124.5***	-119.1***	-122.3***
Observations	25,832	25,832	25,832	25,832	25,832
R-squared	0.003	0.142	0.142	0.143	0.143

Note(s): \*\*\*  $p < 0.01$ , \*\*  $p < 0.05$ , \*  $p < 0.1$

Source: This study

## CONCLUSION AND DISCUSSION

### Conclusion

Utilizing data from Airbnb, this study examined whether and how host personality affects consumers' booking review posting behavior. In addition, this study investigated moderating effect of the property quantity on host personality. The authors applied

text mining approach and OLS model to examine the hypotheses. The empirical results show that: host agreeableness and conscientiousness have a positive influence on review volume and property performance. The influence of host extraversion exerts an inverted-U shape influence on review volume. Moreover, the property quantity moderates the effect of host personality on review volume and property performance.

### Theoretical Implication

Our study makes several important contributions. First, our study contributes to the sharing economy literature in how the hosts' disclosed personality influences the performance of their property. Although previous research has demonstrated host-related quality information cues, such as being a superhost, operating experience, appear to have significant effects on trust from Airbnb travelers (Liang et al., 2020). Little is known about how the host disclosed personality influence review volume and property performance. Our findings directly show that consumers' purchase and review posting behavior can be influenced by hosts' personality.

Second, our research adds to the personality-related literature on the ecommerce platform. prior research about the personality mainly focused on how the individual's personality influences the behavior of themselves, rather than others. Our work expands the scope of the literature, testing how the disclosed personality on the social or ecommerce platform influence others' behavior.

Third, this paper provides fresh evidence regarding the nonlinear effect of host's extraversion on consumers' booking behavior in the accommodation-sharing platform. Moreover, this is the first study to find that the property number of the host can moderate the effect of their disclosed personality.

### Practical Implication

Our study also has some practical implications. First, the study provides practical guidance for the host in peer-to-peer property rental platforms. For property owners, presenting a more agreeableness and conscientiousness about themselves can help hosts attract more booking and reviews for their properties. Moreover, they can also manage their description about themselves according to the number of their listings. Second, for the platforms, they can select the host according to their personality to improve the financial performance of the platforms.

### Limitation

This study has several limitations. First, this study only focuses on the sharing economy platform Airbnb; its results may not be generalized to entire sharing economy rental sector. Second, there are many hosts on the Airbnb platform whose biographical text information is too short to accurately calculate their personality. Third, we used secondary data and were unable to determine the mechanism behind the effects we observed.

## REFERENCE

- Adamopoulos, P., Ghose, A., & Todri, V. (2018). The impact of user personality traits on word of mouth: Text-mining social media platforms. *Information Systems Research*, 29(3), 612-640. <https://doi.org/10.1287/isre.2017.0768>
- Baumgartner, H. (2002). Toward a personology of the consumer. *Journal of consumer research*, 29(2), 286-292. <https://doi.org/10.1086/341578>
- Biswas, B., Sengupta, P., & Chatterjee, D. (2020). Examining the determinants of the count of customer reviews in peer-to-peer home-sharing platforms using clustering and count regression techniques. *Decision Support Systems*, 135, 113324. <https://doi.org/10.1016/j.dss.2020.113324>
- Chung, Y., & Sarnikar, S. (2021). Understanding host marketing strategies on Airbnb and their impact on listing performance: a text analytics approach. *Information Technology & People*. <https://doi.org/10.1108/ITP-10-2020-0718>
- Costa Jr, P. T., & McCrae, R. R. (1992). Four ways five factors are basic. *Personality and individual differences*, 13(6), 653-665. [https://doi.org/10.1016/0191-8869\(92\)90236-I](https://doi.org/10.1016/0191-8869(92)90236-I)
- Ert, E., Fleischer, A., & Magen, N. (2016). Trust and reputation in the sharing economy: The role of personal photos in Airbnb. *Tourism Management*, 55, 62-73. <https://doi.org/10.1016/j.tourman.2016.01.013>
- Goh, K.-Y., Heng, C.-S., & Lin, Z. (2013). Social media brand community and consumer behavior: Quantifying the relative impact of user-and marketer-generated content. *Information Systems Research*, 24(1), 88-107.
- Goldberg, L. R. (1990). An alternative" description of personality": the big-five factor structure. *Journal of personality and social psychology*, 59(6), 1216. <https://doi.org/10.1037/0022-3514.59.6.1216>
- Hassan, M., & Ariño, L. V. C. (2016). Consumer devotion to a different height: How consumers are defending the brand within Facebook brand communities. *Internet Research*, 26(4), 963-981. <https://doi.org/10.1108/IntR-03-2015-0090>
- Kim, H. J., Shin, K. H., & Umbreit, W. T. (2007). Hotel job burnout: The role of personality characteristics. *International Journal of Hospitality Management*, 26(2), 421-434. <https://doi.org/10.1016/j.ijhm.2006.03.006>
- Kluemper, D. H., Rosen, P. A., & Mossholder, K. W. (2012). Social networking websites, personality ratings, and the organizational context: More than meets the eye? 1. *Journal of Applied Social Psychology*, 42(5), 1143-1172. <https://doi.org/10.1111/j.1559-1816.2011.00881.x>
- Kumar, V., & Reinartz, W. (2016). Creating enduring customer value. *Journal of marketing*, 80(6), 36-68. <https://doi.org/10.1509/jm.15.0414>
- Li, X., & Hitt, L. M. (2008). Self-selection and information role of online product reviews. *Information systems research*, 19(4), 456-474.

- Liang, S., Schuckert, M., Law, R., & Chen, C.-C. (2020). The importance of marketer-generated content to peer-to-peer property rental platforms: evidence from Airbnb. *International Journal of Hospitality Management*, 84, 102329. <https://doi.org/10.1016/j.ijhm.2019.102329>
- Mairesse, F., & Walker, M. (2006). *Words mark the nerds: Computational models of personality recognition through language*. Paper presented at the Proceedings of the Annual Meeting of the Cognitive Science Society.
- McCrae, R. R., & John, O. P. (1992). An introduction to the five-factor model and its applications. *Journal of personality*, 60(2), 175-215. <https://doi.org/10.1111/j.1467-6494.1992.tb00970.x>
- Meire, M., Hewett, K., Ballings, M., Kumar, V., & Van den Poel, D. (2019). The role of marketer-generated content in customer engagement marketing. *Journal of marketing*, 83(6), 21-42. <https://doi.org/10.1177/0022242919873903>
- Nieto García, M., Muñoz-Gallego, P. A., Viglia, G., & González-Benito, Ó. (2020). Be social! The impact of self-presentation on peer-to-peer accommodation revenue. *Journal of Travel Research*, 59(7), 1268-1281. <https://doi.org/10.1177/0047287519878520>
- Norman, R. M., & Watson, L. D. (1976). Extraversion and reactions to cognitive inconsistency. *Journal of Research in personality*, 10(4), 446-456. [https://doi.org/10.1016/0092-6566\(76\)90058-1](https://doi.org/10.1016/0092-6566(76)90058-1)
- Park, G., Schwartz, H. A., Eichstaedt, J. C., Kern, M. L., Kosinski, M., Stillwell, D. J., . . . Seligman, M. E. (2015). Automatic personality assessment through social media language. *Journal of personality and social psychology*, 108(6), 934. <https://doi.org/10.1037/pspp0000020>
- Tao, D., Fang, W., Luo, B., & Wan, L. (2022). Which Marketer-generated-content is more effective? An experimental study in the context of a peer-to-peer accommodation platform. *International Journal of Hospitality Management*, 100, 103089.
- Tsai, J. Y., Egelman, S., Cranor, L., & Acquisti, A. (2011). The effect of online privacy information on purchasing behavior: An experimental study. *Information Systems Research*, 22(2), 254-268.
- Tussyadiah, I. P., & Park, S. (2018). When guests trust hosts for their words: Host description and trust in sharing economy. *Tourism management*, 67, 261-272. <https://doi.org/10.1016/j.tourman.2018.02.002>
- Wang, X., Jiang, M., Han, W., & Qiu, L. (2022). Do Emotions Sell? The Impact of Emotional Expressions on Sales in the Space-Sharing Economy. *Production and Operations Management*, 31(1), 65-82. <https://doi.org/10.1111/poms.13527>
- Xie, K., & Mao, Z. (2017). The impacts of quality and quantity attributes of Airbnb hosts on listing performance. *International Journal of Contemporary Hospitality Management*, 29(9), 2240-2260. <https://doi.org/10.1108/IJCHM-07-2016-0345>
- Yarkoni, T. (2010). Personality in 100,000 words: A large-scale analysis of personality and word use among bloggers. *Journal of research in personality*, 44(3), 363-373. <https://doi.org/10.1016/j.jrp.2010.04.001>
- Zabelina, D. L., Robinson, M. D., & Anicha, C. L. (2007). The psychological tradeoffs of self-control: A multi-method investigation. *Personality and individual differences*, 43(3), 463-473. <https://doi.org/10.1016/j.paid.2006.12.015>
- Zhang, L., Yan, Q., & Zhang, L. (2018). A computational framework for understanding antecedents of guests' perceived trust towards hosts on Airbnb. *Decision Support Systems*, 115, 105-116. <https://doi.org/10.1016/j.dss.2018.10.002>



## The Formation Mechanism of Customer Citizenship Behaviors in Open Innovation Community Based on SOR Model

Hua Zhang<sup>1</sup>  
Shuangji Liu<sup>2,\*</sup>

\*Corresponding author

<sup>1</sup> Changzhou University, Changzhou, China, zhanghua@cczu.edu.cn

<sup>2</sup> Henan Finance University, Zhengzhou, China, liushuangji@hafu.edu.cn

### ABSTRACT

Consumer citizenship behaviors such as recommendation, help, and feedback play an important role in the operation and development of open innovation communities. Clarifying the formation mechanism of consumer citizenship behaviors will not only help firms to accurately develop technological innovation strategies but also encourage value co-creation between the firm and consumers. We employ the SOR model and a questionnaire survey of 318 consumers to empirically examine the relationship between the information quality, system function, social capital, and consumer citizenship behaviors of the open innovation community under different environmental stimuli. Structural equation models are used to empirically test the direct and indirect effects on consumer citizenship behaviors. The results show that environmental factors in open innovation communities influence customer behavior from two dimensions: explicit stimulus and implicit stimulus. We also find that the explicit stimulus of open innovation community is helpful to improve customers' self-identity and then stimulates the emergence of their citizenship behaviors. The implicit stimulus of the open innovation community promotes the formation of customers' subjective norms and further improves the generation of citizenship behaviors.

*Keywords:* customer citizenship behaviors, open innovation community, SOR model.

### INTRODUCTION

In the era of digital economy, open innovation has increasingly become an important means for enterprises to shape their competitive advantages. Driven by the new generation of information technologies such as the Internet of Things, big data and cloud computing, more and more enterprises have begun to form open innovation communities to obtain customer ideas, needs and experience, and then in the fuzzy front-end, technological innovation and achievement transformation, etc. Implement value co-creation in all aspects of the value chain (Chesbrough, 2017). Existing studies have found that customer citizenship behaviors play an important role in the operation and development of open innovation communities, not only attracting customers to participate in enterprise value creation, but also promoting the dissemination and diffusion of customer groups' value propositions, professional insights and technical solutions (Chiu, Huang, Cheng, & Hsu, 2019; Zhu, Sun, & Chang, 2016). In this context, how to stimulate the customer citizenship behaviors of the open innovation community has become an important issue for enterprise innovation management.

Customer citizenship behaviors is a voluntary and spontaneous behavior that is conducive to the development of enterprises, mainly manifested by recommendation, help and feedback (Groth, 2005). Customer citizenship behaviors is the fundamental guarantee for enhancing the vitality of open innovation communities, and exploring the formation mechanism of customer citizenship behaviors has significant theoretical and practical significance for improving the operational efficiency of open innovation communities.

In recent years, customer citizenship behavior has attracted continuous attention from the academic community, and related research mainly includes two branches. On the one hand, scholars discussed the connotation and extension of customer citizenship

behaviors in the binary relationship of "enterprise-customer" based on the service-dominant logic, and found that factors such as corporate reputation, brand experience, and sense of fairness have positive effects on customer citizenship behaviors. On the other hand, some scholars take virtual communities as their research objects, and examine the impact of multiple "community-customer" relationships, such as social capital, customers' sense of belonging and happiness, on customer citizenship behaviors (Chiu, Huang, Cheng, & Sun, 2015).

To sum up, although existing research generally believes that customer citizenship behaviors is of great significance to the management and development of virtual communities, the understanding of its formation mechanism is still very vague. Some scholars have discussed the role of virtual community characteristics, customer experience or feelings on customer citizenship behaviors (Gong & Wang, 2023), but there is a lack of in-depth analysis of how external environmental factors that affect individual behavior affect the generation of customer citizenship behaviors. The research results for the object are also very scarce. In view of this, based on the theory of self-identity and social exchange, this paper takes the value co-creation of enterprises and customers as the main line of logic, and through the SOR model and empirical analysis, examines the role of factors such as social capital and platform functions in open innovation communities on customer citizenship behaviors. Mechanism to provide theoretical support for revealing the formation mechanism of customer citizenship behaviors.

## THE RESEARCH HYPOTHESIS

### The Conceptual Model

In the 1970s, scholars such as Mehrabian proposed the SOR model to explain the basic principles of generating consumer buying behavior (Mehrabian & Russell, 1974). They believe that some features of the external environment can affect individual cognitive and emotional states, which in turn drive certain behavioral responses of consumers. The SOR model consists of three interrelated elements, namely stimulus, organism, and response.

In order to analyze the formation mechanism of customer citizenship behaviors in the open innovation community, this paper designs a conceptual model as shown in Figure 1 according to the research paradigm of the SOR model. We believe that customer citizenship behaviors belongs to approach behavior, which is a positive response of customers to actively provide help and support to others; customers receive two different types of stimuli, explicit and implicit, in the open innovation community. Cognitive activities for performance and emotional activities for social norms affect the generation of citizenship behaviors such as help, recommendation and feedback. In order to further demonstrate the above relationship, this paper will discuss the relevant research hypotheses of the conceptual model in Figure 1 in the next section, and then make a theoretical foundation for empirical analysis.

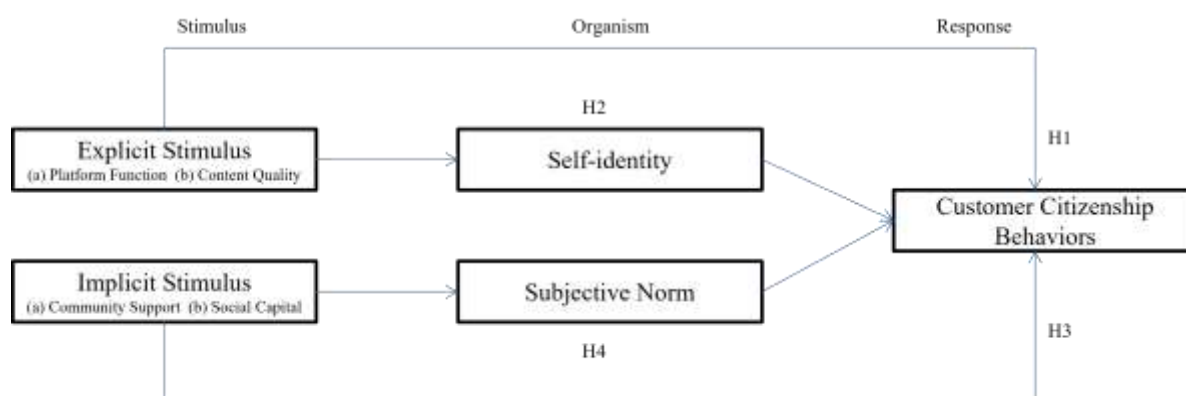

Figure 1: Conceptual model

### Explicit Stimuli and Customer Citizenship Behaviors

The appearance of an open innovation community is an Internet platform established by enterprises with the help of a new generation of information technology (Chesbrough, 2017). In an open innovation community, the stimuli that can be perceived by customers originate from external environments such as platform functions and community support. In this paper, referring to previous studies such as Ul Islam and Rahman (2017), Mollen and Wilson (2010), the characteristics of open innovation

communities (platform function, content quality, community support and social capital, etc.) According to the concealment of information processing, the external environmental stimuli that can be perceived by customers are divided into two types: explicit stimuli and implicit stimuli. Specifically, explicit stimulus is the "tangible" environmental factors such as platform functions and content quality of an open innovation community that have a direct or explicit impact on customers, and implicit stimulus is an indirect stimulus to customers. "Intangible" environmental factors such as social capital and sense of community support in an open innovation community that may have an implicit influence.

The SOR model points out that when people are highly related to the external environment, individual behavior is more likely to be stimulated by the direct value and rare features of the external environment (Mehrabian & Russell, 1974; Ul Islam & Rahman, 2017). Especially for those community "opinion leaders" and active customers, they will pay more attention to the personal experience and utility of participating in community activities, and their citizenship behaviors will continue with the continuous improvement of the platform function and content quality of the open innovation community emerge. The higher the content quality of the open innovation community, the easier it is for customers to obtain novel and useful information and knowledge, and the better customer experience and satisfaction drive customers to actively integrate into the value creation process of the enterprise, and ultimately stimulate the emergence of customer citizenship behaviors. Based on the above analysis, this paper proposes the following research hypotheses:

H1a: The content quality of open innovation communities is positively correlated with customer citizenship behaviors.

H1b: The platform function of an open innovation community is positively related to customer citizenship behaviors.

Although the SOR model points out the mediating mechanism between the body (individual cognition or emotion) between external environmental stimuli and individual responses, few studies discuss the specific effects of different types of external environmental stimuli on customer behavior. In view of this, based on the theory of self-identity, this paper further analyzes the mediating mechanism of individual cognition in the open innovation community between explicit stimuli and customer citizenship behaviors. We believe that, compared with individual emotions, explicit stimuli such as platform functions and content quality in open innovation communities will have a more significant impact on individual cognition.

Self-identity theory points out that cognition is the precondition of behavior, and it is the self-evaluation formed by the individual in response to the external environment, that is, a subjective interpretation of the answer to the "true self". Therefore, the stronger the self-identity, the more likely people are to perform the behavior of the corresponding social role. The customers of the open innovation community have dual roles. They are not only the customers of the company's products and services in real life, but also the innovators who contribute information and knowledge to the company in the virtual space. Based on the above analysis, this paper proposes the following research hypotheses:

H2a: Customer self-identity has a mediating effect between content quality and customer citizenship behaviors in open innovation communities.

H2b: Customer self-identity has a mediating effect between the platform function of open innovation community and customer citizenship behaviors.

### **Implicit stimuli and customer citizenship behaviors**

Different from the explicit stimuli of open innovation communities such as platform functions and content quality, the characteristics of open innovation communities such as community support and social capital stimulate customer behavior in a more subtle way. According to the theoretical framework of the SOR model, when individuals lack sufficient motivation and ability to process external information, people will reduce the investigation of the direct value and dominant characteristics of external information, and instead focus on the indirect impact of information. Previous studies have pointed out that the social capital and sense of community support of open innovation communities are important factors that characterize their indirect effects.

Community support is the overall opinion and evaluation of customers on the virtual community in terms of attaching importance to customer contributions and caring about customer welfare. According to the social exchange theory, the interaction between customers and open innovation communities is not only an economic behavior, but also an emotional exchange for spiritual benefits; a high sense of community support will establish a good industry image for enterprises, attracting more customers pay attention to the products and services of enterprises, and motivate customers to take actions that are beneficial to community development (Tinc, Goodspeed, & Sorensen, 2021).

Social capital is the sum of available resources embedded in interpersonal relationships and social networks. Individuals or organizations with rich social capital are more likely to win the trust of others, establish extensive cooperative relations with the outside world by virtue of their good reputation, and then make full use of the scale effect of resource integration. The social capital of the open innovation community is based on the social connection, mutual trust and collective action among customers, through the interaction and cooperation between enterprises and customers and customer groups to achieve a win-win situation (Yao, Tsai, & Fang, 2015). Existing studies have shown that social capital in virtual communities has a positive impact on customers' knowledge sharing, loyalty and citizenship behavior. In summary, this paper proposes the following research hypotheses:

H3a: The social capital of an open innovation community is positively related to customer citizenship behaviors.

H3b: The sense of community support in an open innovation community is positively related to customer citizenship behaviors.

On the basis of the above analysis, this paper further discusses the potential mediating mechanism between the implicit stimuli of open innovation communities and customer citizenship behavior according to the social influence theory. We believe that, relative to individual cognition, implicit stimuli such as social capital and community support in open innovation communities have an important impact on individual emotions. Social influence theory points out that subjective norm is a proxy variable that characterizes individual emotions; when the relationship between an individual and the external environment is weak, people are more likely to be influenced by others and produce behavioral changes in a lower way of information processing. At this time, subjective norm affects customer behavior. formation is decisive.

Subjective norm is the emotion that individuals have when deciding whether to perform a certain behavior in order to gain the approval of others (Ajzen, 1991). Social influence theory points out that people's behaviors are often under invisible pressure, and the concepts, standards and conventions of major social groups (such as family members, colleagues, friends, etc.) will affect the formation of individual attitudes, which will lead to the convergence of people's behaviors (Kelman, 1958; Li, 2013). Therefore, subjective norm has a positive correlation with individual approach behavior. For an open innovation community, a high level of subjective norms not only motivates customers to interact with enterprises and other community members, but also constrains customer behavior, urging them to participate in community activities according to the community members' recognized decision-making preferences and communication patterns (Lin & Huang, 2013). Existing literature shows that subjective norms play an important role in the operation of virtual communities. Li et al. (2019) believed that the subjective norm of the virtual community is an exogenous incentive factor, which is related to the customer's "altruism" Knowledge creation behavior is positively correlated. Therefore, this paper proposes the following research hypotheses:

H4a: Customer subjective norm has a mediating effect between the social capital of open innovation community and customer citizenship behaviors.

H4b: Customer subjective norms have a mediating effect between community support and customer citizenship behaviors in open innovation communities.

## RESEARCH METHOD

### Samples and Data Sources

This paper collects research data through questionnaires. Before the formal investigation, we compiled a questionnaire based on the mature scales of the existing literature, and invited 5 senior executives of the enterprise and active customers of the open innovation community to propose amendments to the content, structure and writing logic of the questionnaire. The final draft of the questionnaire is formed on the basis of the small sample test.

The formal investigation of this study lasted 4 months from March 2021 to June 2021. From March to May 2021, in order to improve the efficiency of the investigation, with the help of senior management and active customers of the enterprise, through online discussion areas, WeChat Moments, and emails, we will conduct an open-ended survey for Huawei, Haier and Xiaomi Customers of the innovation community distributed 600 electronic questionnaires. The above three companies are industry leaders who attach importance to technological innovation and have many years of experience in operating open innovation communities. The size of the community and the number of active customers is higher than those of similar domestic companies, which are suitable for empirical research in this paper. In June 2021, we further screened the 380 questionnaires collected, excluding the non-response to key items, regular answers, and short filling time, and finally got 318 valid questionnaires, with an effective recovery rate of 53%. In addition, to assess possible nonresponse bias, we compared the questionnaires returned in the early and late periods and found no significant difference in customer characteristics. Therefore, the problem of non-response bias in this study is not serious.

### Variable measurement

All variables in this study were measured using a 5-level Likert scale (1 means "completely disagree", 5 means "completely agree") to reflect the respondents' recognition of the measurement items.

1) **Dependent variable:** Using the scale of Zhu et al. (2016), customer citizenship behavior is measured with 10 items from the three dimensions of recommendation, help and feedback behavior.

2) **Independent variable:** The platform function is measured according to the scale of Jang et al. (2008), using 3 items such as information exchange and interaction efficiency; the content quality is measured according to the scale of Jang et al. (2008), which is measured from 4 items such as content novelty and reliability; Social capital is measured from the scale of Yao et al. (2015), from 4 items such as social connection and interpersonal relationship; the sense of community support is measured from the scale of Ye et al. (2015), from 3 items of values, opinions and concerns.

3) **Mediating variables:** According to the research of Xiong et al. (2018), self-identity is measured using three items; the subjective norm draws on the research of Li et al. (2019), using 3 items such as "most people who influence me are using this community" and "I think other customers need me to join". The scale structure is shown in Table 1.

Table 1: Scale structure

Variables and Items	Factor Loadings
Platform Function (PF): Cronbach's $\alpha=0.830$ , CR=0.831, AVE=0.621	
PF1. Customers can conduct convenient information exchange and interpersonal communication in the community	0.798
PF2. Customers can quickly ask and answer questions in the community	0.787
PF3. Customers in the community interact frequently with enterprises	0.779
Content Quality (CQ): Cronbach's $\alpha=0.873$ , CR=0.873, AVE=0.633	
CQ1. The content of the community is detailed and authoritative	0.759
CQ2. The content of this community is comprehensive and fresh	0.817
CQ3. The information in this community is accurate and reliable	0.771
CQ4. This community has a wealth of sources of information	0.834
Community Support (CS): Cronbach's $\alpha=0.843$ , CR=0.843, AVE=0.642	
CS1. My goals and values align with this community	0.797
CS2. The community is willing to assist me when necessary	0.794
CS3. This community cares about my opinion	0.812

Social Capital (SC): Cronbach's $\alpha=0.833$ , CR=0.834, AVE=0.556	
SC1. Maintain close contact with community members	0.751
SC2. Commitment among community members	0.724
SC3. Community members will not take advantage of possible opportunities to steal the interests of others	0.772
SC4. Community members have a unified vision and communication style	0.735
Self-Identity (SI): Cronbach's $\alpha=0.831$ , CR=0.831, AVE=0.622	
SI1. I think it is necessary to create value for the community	0.767
SI2. I think there should be a contribution to the community	0.809
SI3. I consider myself someone of value to the community	0.789
Subjective Norm (SN): Cronbach's $\alpha=0.825$ , CR=0.826, AVE=0.612	
SN1. Most of the people who influence me are using the community	0.780
SN2. More customers motivate me to use the community	0.788
SN3. I think other customers need me to join	0.779
Customer Citizenship Behaviors (CB): Cronbach's $\alpha=0.887$ , CR=0.804, AVE=0.579	
Recommended Behavior (RB): Cronbach's $\alpha=0.857$ , CR=0.858, AVE=0.669	
RB1. I would proactively recommend this community to those around me	0.814
RB2. I rate this community positively from others	0.828
RB3. I recommend this community to anyone interested in enterprise products	0.811
Helping Behavior (HB): Cronbach's $\alpha=0.861$ , CR=0.861, AVE=0.674	
HE1. I am willing to help other customers of the community with problems	0.842
HE2. I take the initiative to teach others how to properly use platform features	0.817
HE3. I often help other customers of the community	0.804
Feedback Behavior (FB): Cronbach's $\alpha=0.860$ , CR=0.860, AVE=0.606	
FB1. I actively participate in community customer satisfaction surveys	0.778
FB2. I am able to provide useful feedback on improving platform functionality	0.776
FB3. I provide valid information in a community survey	0.782
FB4. I often make suggestions for improving the quality of content in the community	0.777

Table 2: Correlation coefficient matrix

Variable	Mean	SD	1	2	3	4	5	6	7
1. PF	3.144	0.756	<b>0.788</b>						
2. CQ	3.231	0.892	0.222**	<b>0.796</b>					
3. CS	3.247	0.765	0.405**	0.285**	<b>0.801</b>				
4. SC	3.176	0.729	0.484**	0.229**	0.526**	<b>0.746</b>			
5. SI	3.354	0.797	0.300**	0.245**	0.415**	0.327**	<b>0.789</b>		
6. SN	3.328	0.726	0.400**	0.256**	0.367**	0.389**	0.316**	<b>0.782</b>	
7. CB	3.379	0.595	0.490**	0.410**	0.546**	0.528**	0.514**	0.455**	<b>0.761</b>

Note: \*\*p < 0.01; The diagonal is the square root of AVE.

## EMPIRICAL ANALYSIS

### Measurement Model

This paper uses structural equations (SEM) to carry out empirical analysis. As shown in Table 1, the Cronbach's alpha coefficient and combined reliability (CR) of all variables are greater than the critical value of 0.7, indicating that the reliability of the scale is good; The standardized factor loading of each item is greater than 0.7, and the average variance extraction (AVE) is greater than 0.5, indicating that the scale has high convergent validity. It can be seen from Table 2 that the square root of the AVE value of all variables on the diagonal is greater than the correlation coefficient of its corresponding row and column, which shows that the discriminant validity between variables is good. In addition, Harman's one-factor test of all variables showed that the cumulative variance contribution of the first common factor was 33.5%, which was below the 40% critical value. Therefore, the problem of common method variance in this study is not serious.

## Structural Model

In this paper, Amos 23.0 software is used to test the path coefficient and research hypothesis of the structural model. The main indicators ( $\chi^2=499.483$ ,  $\chi^2/df=1.294$ , RMSEA=0.030, TLI=0.974, CFI=0.977, NFI=0.905, IFI=0.977) all satisfy Corresponding criteria indicate that the structural model has a good fit. The hypothesis test results are shown in Table 3 and Table 4.

Table 3: Direct effect analysis

Variable Relationship	Regression	S.E.	C.R.	p
CQ→CB	0.133	0.036	3.720	<0.001
PF→CB	0.129	0.053	2.451	0.014
SC→CB	0.132	0.058	2.271	0.023
CS→CB	0.150	0.053	2.834	0.005
PF→SI	0.350	0.072	4.840	<0.001
CQ→SI	0.201	0.061	3.304	<0.001
CS→SN	0.223	0.081	2.742	0.006
SC→SN	0.323	0.085	3.794	<0.001
SI→CB	0.210	0.045	4.720	<0.001
SN→CB	0.111	0.047	2.360	0.018

Table 3 shows that the content quality ( $b=0.133$ ,  $p<0.001$ ) and platform function ( $b=0.129$ ,  $p<0.01$ ) of the open innovation community are significantly positively correlated with customer citizenship behavior. Therefore, it is assumed that H1a and H1b are supported. The regression coefficients of social capital, community support and customer citizenship behavior of open innovation communities are 0.132 ( $p<0.05$ ) and 0.150 ( $p<0.01$ ), respectively. Therefore, it is assumed that H3a and H3b are supported.

Table 4: Bootstrap-based mediation effect analysis

Path Relationship	Effect	Regression	95% Confidence	Mediation Effect
PF→SI→CB	Total Effect	0.456	[0.353, 0.582]	29%
	Indirect Effect	0.130	[0.079, 0.201]	
	Direct Effect	0.326	[0.233, 0.440]	
CQ→SI→CB	Total Effect	0.314	[0.229, 0.415]	32%
	Indirect Effect	0.100	[0.053, 0.180]	
	Direct Effect	0.214	[0.135, 0.300]	
CS→SN→CB	Total Effect	0.468	[0.357, 0.587]	22%
	Indirect Effect	0.104	[0.061, 0.167]	
	Direct Effect	0.364	[0.250, 0.486]	
SC→SN→CB	Total Effect	0.460	[0.347, 0.582]	25%
	Indirect Effect	0.115	[0.062, 0.188]	
	Direct Effect	0.345	[0.218, 0.489]	

Furthermore, this paper adopts the Bootstrap method with bias-corrected percentile to test the mediating effect of the structural model. As shown in Table 4, under the condition of 2000 repeated sampling and 95% confidence interval, the confidence interval of the indirect effect of customer self-identification between the function of open innovation platform and customer citizenship behavior is [0.079, 0.201], and the confidence interval of customer self-identification is [0.079, 0.201]. The confidence interval of the indirect effect between community content quality and customer citizenship behavior is [0.053, 0.180], indicating that customer self-identity has a significant partial mediation effect between explicit stimuli and customer citizenship behavior in open innovation communities. Therefore, it is assumed that H2a and H2b are supported. In the same way, the confidence interval of the indirect effect of customer subjective norms on the support of the open innovation community and the customer's citizenship behavior is [0.061, 0.167], and the confidence interval of the indirect effect between the social capital of the open community and the customer's citizenship behavior is [0.061, 0.167]. 0.062, 0.188], indicating that customer subjective norm has a significant partial mediation effect between implicit stimuli and customer citizenship behavior in open innovation communities. Therefore, it is assumed that H4a and H4b are supported.



## CONCLUSION AND IMPLICATIONS

From the perspective of "community-customers" value co-creation, this paper uses the SOR model to explore the mediating mechanism of the external environmental stimuli such as content quality and social capital in open innovation communities affecting customers' citizenship behaviors. The formation mechanism of citizenship behavior. The research found that: Customer citizenship behavior originates from the individual's psychological and cognitive activities, and is the product of the customer's attitude and behavior changes caused by processing external information. Customer self-identity plays a partial mediating effect between explicit stimuli and citizenship behavior in open innovation communities. Subjective norms play a partial mediating effect between implicit stimuli and customer citizenship behavior in open innovation communities.

The theoretical contributions of this study are: On the one hand, based on the SOR model, self-identity and social exchange theory, the environmental factors, individual cognition and emotion, and customer citizenship behavior of open innovation communities are discussed from the perspectives of explicit and implicit stimuli. The interaction relationship and its intermediary mechanism of the SOR model further expand the application scenarios of the SOR model and improve its theoretical explanatory power in the field of customer behavior in virtual communities. On the other hand, from the perspective of "community-customer" value co-creation, this paper examines the formation mechanism of customer citizenship behavior in open innovation communities, which not only enriches the empirical research results of customer behavior literature, but also promotes value co-creation from the context of open innovation communities. The construction of the theoretical system of creation.

The management implications of this paper include the following three points. First, enterprises should actively promote the deep coupling of innovation chain and value chain. This paper finds that the content quality and platform functions of open innovation communities are positively related to customer citizenship behavior. Therefore, enterprises can use the open innovation community as an important carrier to form an innovation chain, and integrate various innovation entities to participate in the technological innovation process of the enterprise. Second, enterprises must carefully design the incentive mechanism for open innovation communities. The stronger the community support felt by customers, the more common their subjective norms and citizenship behaviors in the open innovation community. As an important means to improve the sense of community support, the reward mechanism plays an active role in the operation of the open innovation community. Third, enterprises should give full play to the leading role of "opinion leaders". "Opinion leaders" are not only active customers of the open innovation community, but also a key force connecting community members' interpersonal relationships and social networks. Their behaviors determine to a large extent the information dissemination, public opinion orientation and operational efficiency of the entire community.

The research data in this paper comes from questionnaires. The main conclusions may be affected by the subjective preferences of the respondents and individual characteristics, and there may be measurement biases. Subsequent research can integrate the survey data and business operation data to improve the robustness of the research conclusions. In addition, this paper does not consider the role of moderator variables on customer citizenship behavior, and analyzing the moderating effects of factors such as reward mechanism and community culture can be an important direction for future research.

## ACKNOWLEDGEMENT

This research was funded by the National Social Science Fund of China, grant number 21BGL068; the Guangdong Planning Office of Philosophy and Social Science, grant number GD20CGL05; Cultural Research Special Project of Henan Xing Cultural Engineering, grant number 2022XWH236; General Project of Humanities and Social Sciences Research in Colleges and Universities in Henan Province, grant number 2024-ZDJH-855.

## REFERENCES

- Ajzen, I. (1991). "The theory of planned behavior." *Organizational Behavior and Human Decision Processes*, 50(2), 179-211. [https://doi.org/10.1016/0749-5978\(91\)90020-T](https://doi.org/10.1016/0749-5978(91)90020-T)
- Chesbrough, H. (2017). "The future of open innovation." *Research-Technology Management*, 60(1), 35-38. <https://doi.org/10.1111/j.1467-9310.2010.00605.x>
- Chiu, C. M., Huang, H. Y., Cheng, H. L., & Hsu, J. S. (2019). "Driving individuals' citizenship behaviors in virtual communities through attachment." *Internet Research*, 29(4), 870-899. <https://doi.org/10.1108/INTR-07-2017-0284>

- Chiu, C. M., Huang, H. Y., Cheng, H. L., & Sun, P. C. (2015). "Understanding online community citizenship behaviors through social support and social identity." *International Journal of Information Management*, 35(4), 504-519. <https://doi.org/10.1016/j.ijinfomgt.2015.04.009>
- Gong, T., & Wang, C. Y. (2023). "Unpacking the relationship between customer citizenship behavior and dysfunctional customer behavior: The role of customer moral credits and entitlement." *Journal of Service Theory and Practice*, 33(1), 110-137. <https://doi.org/10.1108/JSTP-12-2021-0256>
- Groth, M. (2005). "Customers as good soldiers: Examining citizenship behaviors in internet service deliveries." *Journal of Management*, 31(1), 7-27. <https://doi.org/10.1177/0149206304271375>
- Islam, J. U., & Rahman, Z. (2017). "The impact of online brand community characteristics on customer engagement: An application of Stimulus-Organism-Response paradigm." *Telematics and Informatics*, 34(4), 96-109. <https://doi.org/10.1016/j.tele.2017.01.004>
- Jang, H., Olfman, L., Ko, I., Koh, J., & Kim, K. (2008). "The influence of on-line brand community characteristics on community commitment and brand loyalty." *International Journal of Electronic Commerce*, 12(3), 57-80. <https://doi.org/10.2753/JEC1086-4415120304>
- Kelman, H. C. (1958). "Compliance, identification, and internalization: Three processes of attitude change." *Journal of Conflict Resolution*, 2(1), 51-60. <https://doi.org/10.1177/002200275800200106>
- Li, C. Y. (2013). "Persuasive messages on information system acceptance: A theoretical extension of elaboration likelihood model and social influence theory." *Computers in Human Behavior*, 29(1), 264-275. <https://doi.org/10.1016/j.chb.2012.09.003>
- Li, H., Peng, L. H., & Hong, C. (2019). "Research on incentive factors of knowledge innovation behavior of virtual community customers from the perspective of internal and external students." *Library and Information Service*, 63(8), 45-56. <https://doi.org/10.13266/j.issn.0252-3116.2019.08.007> (in Chinese).
- Lin, F. R., & Huang, H. Y. (2013). "Why people share knowledge in virtual communities?" *Internet Research*, 23(2), 133-159. <https://doi.org/10.1108/10662241311313295>
- Mehrabian, A., & Russell, J. A. (1974). *An approach to environmental psychology*. Cambridge: The MIT Press.
- Mollen, A., & Wilson, H. (2010). "Engagement, telepresence and interactivity in online consumer experience: Reconciling scholastic and managerial perspectives." *Journal of Business Research*, 63(9-10), 919-925. <https://doi.org/10.1016/j.jbusres.2009.05.014>
- Tinc, P. J., Goodspeed, M. M., & Sorensen, J. A. (2021). "Understanding trends in PTO shielding using Kelman's processes of change." *Journal of Agromedicine*, 26(2), 193-198. <https://doi.org/10.1080/1059924X.2020.1795030>
- Ul Islam, J., & Rahman, Z. (2017). "The impact of online brand community characteristics on customer engagement: An application of Stimulus-Organism-Response paradigm." *Telematics and Informatics*, 34(4), 96-109. <https://doi.org/10.1016/j.tele.2017.01.004>
- Xiong, Y., Cheng, Z., Liang, E., & Wu, Y. (2018). "Accumulation mechanism of opinion leaders' social interaction ties in virtual communities: Empirical evidence from China." *Computers in Human Behavior*, 82, 81-93. <https://doi.org/10.1016/j.chb.2018.01.005>
- Yao, C. Y., Tsai, C. C., & Fang, Y. C. (2015). "Understanding social capital, team learning, members'e-loyalty and knowledge sharing in virtual communities." *Total Quality Management & Business Excellence*, 26(5), 619-631. <https://doi.org/10.1080/14783363.2013.865918>
- Ye, H. J., Feng, Y., & Choi, B. C. (2015). "Understanding knowledge contribution in online knowledge communities: A model of community support and forum leader support." *Electronic Commerce Research and Applications*, 14(1), 34-45. <https://doi.org/10.1016/j.eleap.2014.11.002>
- Zhu, D. H., Sun, H., & Chang, Y. P. (2016). "Effect of social support on customer satisfaction and citizenship behavior in online brand communities: The moderating role of support source." *Journal of Retailing and Consumer Services*, 31, 287-293. <https://doi.org/10.1016/j.jretconser.2016.04.013>

## The Study of e-Business Models in Hospitality Management: Comparing Hotel Reservation Systems of Booking.com, Expedia and Agoda

Cheng-Hao Tsai<sup>1,\*</sup>

\*Corresponding author

<sup>1</sup> HEC Liège Executive Education, Management School- Liège Université, Liège, Belgium, Executive Doctorate in Business Administration EDDBA Student, brian690407@gmail.com

### ABSTRACT

The rapid evolution of e-business models has brought about transformative changes in various industries, including the hospitality sector. The dynamic landscape of hospitality management has undergone substantial transformations with the advent of e-business models. This paper undertakes an in-depth exploration of e-business models within the realm of hospitality management, with a specific focus on three prominent online reservation systems – Booking.com, Expedia, and Agoda. Through a rigorous comparative analysis, this study aims at unraveling the intricacies of these platforms, offering valuable insights into their operational frameworks, market positioning, and strategies for customer engagement.

Adopting the business model concept and Business Model Canvas (BMC) theoretical framework, conceived for business management approach, this paper encompasses the nine building block criteria formulated by Osterwalder and Pigneur (2010). The findings highlight nuanced differentiations in the e-business models adopted by the selected platforms. While all three systems provide essential booking functionalities, their approaches to expansion, partnership networks, and customer loyalty initiatives diverge significantly. Additionally, the study unveils varying degrees of success in fostering customer trust and engagement, shedding light on the determinants influencing different types of users' preferences for particular platforms.

Furthermore, this research examines the implications of e-business models on hospitality management. It explores avenues for innovation, spotlighting areas where each platform can leverage its strengths to maintain a competitive advantage in an ever-evolving digital milieu. Moreover, it addresses challenges related to data privacy, security, and customer satisfaction that have gained prominence in the online hospitality management sphere.

By offering an extensive comparative analysis of e-business models in hospitality management, this study contributes both to scholarly discourse and practical insights for industry professionals. As e-Business continues to reshape hospitality management, comprehending the distinct strategies of platforms such as Booking.com, Expedia, and Agoda would be pivotal for stakeholders navigating this dynamic and competitive environment. This research serves as a foundational platform for future investigations and guides strategic decision-making for hospitality enterprises and online booking platform providers.

*Keywords:* E-Business model, hospitality management, hotel reservation system

### INTRODUCTION

The ever-evolving landscape of e-business approaches has ushered in profound transformations across diverse industries, and the domain of hospitality is no exception. The realm of hospitality management has witnessed substantial paradigm shifts due to the pervasive influence of e-business strategies. This study delves deeply into the intricate interplay between e-business and hospitality management, focusing specifically on the utilization of e-business models within three key online booking systems: Booking.com, Expedia, and Agoda. The primary objective of this research is to undertake a meticulous comparison and analysis of these platforms, aiming to extract valuable insights into their operational intricacies, market positioning, and customer engagement strategies.

The hospitality management landscape has undergone profound metamorphosis owing to the infusion of e-business strategies. This study undertakes a comprehensive inquiry into the symbiotic relationship between e-business and hospitality management, with a focused examination of three prominent online reservation systems: Booking.com, Expedia, and Agoda. The primary objective of this research is to intricately compare and analyze these platforms, thereby extracting invaluable insights into their operational modalities, market positioning, and strategies for customer engagement.

Guided by the imperative to advance the theoretical and practical comprehension of digital business models within the analyzed sector, this research probes three fundamental questions:

RQ 1: What are the pivotal distinctions underpinning various digital business models, and what factors precipitate these

disparities?

RQ 2: What are the core characteristics inherent to digital business models operating within these specific segments?

RQ 3: Do these segments share common service providers, or are they catered to by distinct entities? Then, what factors influence these choices?

The dedicated exploration of these research questions seeks to illuminate the increasingly pivotal role of digital business models, profoundly shaping the terrain of tourism and hospitality. These models not only impact the field's dynamics but also facilitate more sustainable business practices compared to conventional models, particularly in the realm of resource utilization and consumption patterns.

This endeavor also aspires to enrich the literature in entrepreneurship and strategic management by delving into the fundamental tenets of prevalent digital business models. Furthermore, the study aims to decipher the contrasting dynamics between a prominent mainstream hospitality segment and a niche counterpart, unraveling the intricate drivers that underscore such distinct trajectories. As such, the study endeavors to bolster both theoretical and practical insights into the bedrock of digital business models, steered by an exploratory research methodology.

To fulfill these ambitions, the ensuing sections of this paper traverse a comprehensive review of existing knowledge in both segments. This is succeeded by a lucid exposition of the research methodology employed, culminating in the presentation of pertinent findings. Subsequently, a meticulous comparison between the two segments is drawn, paving the way for cogent conclusions.

Employing a comprehensive blend of methods, this study merges quantitative data analysis with qualitative exploration. The quantitative facet encompasses a range of metrics, encompassing factors like user adoption rates, booking volumes, and customer satisfaction indicators, garnered from a diverse spectrum of lodgings. Simultaneously, the study delves into the unique attributes that set each platform apart, delving into aspects such as user-friendliness, pricing mechanisms, and supplementary offerings.

The findings spotlight nuanced differentiations in the e-business models embraced by these selected platforms. While all three platforms facilitate booking services, their strategies for expansion, partnership networks, and fostering customer loyalty diverge significantly. Moreover, the study unveils disparities in their success rates in building customer trust and fostering sustained engagement, providing insights into the factors influencing users' preferences for specific platforms.

Beyond this, the research delves into the transformational influence of e-business models on the broader hospitality landscape. It unearths novel pathways for innovation, pinpointing domains where each platform can harness their strengths to maintain a competitive edge within the dynamic digital environment. Additionally, the study addresses challenges tied to data privacy, security, and customer contentment—now pivotal factors in the realm of online hospitality management.

This study serves as a guiding light for scholars and practitioners in the hospitality industry, offering comprehensive insights as e-business continues to reshape the landscape. In an era of rapid change and intense competition, comprehending the operational dynamics of platforms such as Booking.com, Expedia, and Agoda becomes paramount for stakeholders in this swiftly evolving ecosystem. This research lays the foundation for further inquiries and aids decision-making for hoteliers and online booking platform providers alike.

## LITERATURE REVIEW

The contemporary digital landscape has sparked a paradigm shift in business models across industries, prominently evident in the hospitality sector. This literature review delves into the realm of e-business models within hospitality management, with a specific focus on conducting a comparative analysis of three renowned reservation systems: Booking.com, Expedia, and Agoda.

The foundational importance of business models is highlighted by Härting, who stress their role as blueprints for organizational functioning (Härting et al., 2018). While multiple interpretations of business models exist, a cohesive understanding emerges from an array of scholarly viewpoints (Massa, 2017; Zott, 2011; Fielt, 2014). Although a universally accepted definition remains elusive, consensus centers on core elements. For this paper's scope, we adopt a succinct interpretation: a business model delineates an organization's method of delivering user value and generating revenue. This definition resonates with prevailing perspectives and encapsulates the essence of business models. Among available frameworks for scrutinizing business model traits, the business model canvas (BMC) gains prominence. Originating from Osterwalder and Pigneur's seminal work (Osterwalder, 2010) which draws on Osterwalder's earlier dissertation (Osterwalder, 2004), this canvas offers a comprehensive schema for dissecting and analyzing business models. Widely embraced in academia and corporate spheres, the BMC's theoretical and practical utility underscores its integration into this study to dissect business model characteristics and compare digital business models in the examined segments.

Digital business models, fueled by information and communication technologies, diverge substantively from traditional counterparts (Voigt, 2015). The transformative potential of digital technologies facilitates novel value propositions and operational modalities across business model components. Remane et al. (Remane, 2017) emphasize specific differentiators, including the minimal marginal costs of digital business models and the amplifying network and platform effects. Härting et al. (2018) extend this notion, shedding light on resource efficiencies, process enhancements, cost reductions, production flexibility, and accelerated product introductions as hallmarks of digital business models. Brousseau and Penard (2007) illuminate the composite nature of digital business models, incorporating platform roles of intermediation, assembling, and knowledge management—a trifold dynamic evident in online travel agencies.

Digital business models challenge entrenched presumptions of conventional models, notably those centered on physical locales and human interactions for customer satisfaction (Weill, 2013). The transformation extends to core business processes, organizational roles, and data utilization—a pivotal resource within the enterprise ecosystem. The resulting process optimization contributes to resource rationalization while concurrently reshaping consumption patterns, aligning with sustainability principles.

Shaughnessy (2016) defines digital platforms as commercial networks enabling interactions among participants. Creatively harnessed, such platforms engender market disruption and confer formidable competitive edges. However, misconceptions about platforms pervade the business landscape. Muzellec et al. (2015) underscore the essence of dual value propositions: catering to customers and service providers. A two-sided market dynamics prevails, necessitating equilibrium between user groups to leverage network effects—a symbiotic cycle where user influx attracts providers and vice versa. Notably, digital platforms can encompass dual or multi-sided orientations, giving rise to interconnected "business ecosystems," pivotal for platform success. Ecosystem leadership entails orchestrating mutual value propositions and navigating intricate relationships (Muzellec, 2015).

Tourism, an early adopter of digital transformation, capitalizes on the sector's intrinsic attributes—intangibility, remote engagement, and information-rich context (Crnojevac, 2010). The advent of information and communication technologies has reconfigured the tourism landscape, spawning novel opportunities and challenges (Ruiz-Gómez, 2018; Mihajlović, 2015; Elliot, 2010). Digital tourism, a cornerstone of this evolution, engenders new business models and prompts a paradigm shift in understanding tourism's underpinnings (Reinhold, 2017). These digital business models span the entire tourist journey—preparation and reservation, consumption, and post-experience evaluation phases—providing seamless access to information, enhancing experiences, and fostering post-trip engagement. Notably, online travel agencies like Booking.com, Expedia, and Agoda spearhead the evolution, facilitating convenient accommodation bookings (Dutta, 2017; Karlsson, 2017).

Accommodation booking, a pivotal phase of the tourism journey, embodies complexity (Jensen, 2018; Sjekavica, 2017). Successful digital service providers employ sophisticated strategies. Virtual communities play a pivotal role in tourists' decision-making, with TripAdvisor serving as a notable influencer. User-generated content within these communities shapes perception and choices, underlining its significance for accommodation providers. Coopetition—a concurrent blend of cooperation and competition—characterizes the hospitality sector (Bilbil, 2018). Horizontal and vertical coopetition dynamics manifest, wherein hotels collaborate with platforms while concurrently competing for direct bookings.

This literature review casts light on the landscape of e-business models in hospitality management, underscored by a detailed comparative analysis of Booking.com, Expedia, and Agoda. The profound influence of digital technologies on the tourism domain emerges, reshaping customer experiences and recalibrating industry norms. The accommodation booking segment, a focal point of this inquiry, reveals the intricate interplay of digital platforms, user-generated content, and coopetition dynamics. As the hospitality landscape continues its digital journey, deeper exploration into these e-business models stands imperative for researchers, practitioners, and industry stakeholders alike.

The Business Model Concept and Business Model Canvas (BMC) theoretical framework, conceived for business management, have gained prominence since the 1990s. This framework, applied to internet services and digital businesses, describes the blueprint adopted by businesses for internal and external value creation (Zott, Amit, & Massa, 2011). Teece (2010) defines a business model as an internal and external framework for comprehending and producing stakeholder value. It serves as a conduit for delivering customer needs and monetizing them into enterprise returns and profits. Three perspectives—value creation, value proposition, and value capture—form the basis for business growth within this framework.

Debates persist within the literature, addressing the absence of a universally accepted global definition that integrates business model elements (Shafer, Smith, & Linder, 2005). The discourse also delves into whether business models are static or dynamic (Demil & Lecocq, 2010). The business model's role in representing and developing strategic choices to foster enterprise and customer value is significant (Shafer et al., 2005). The Business Model Canvas (BMC) is a versatile tool adopted by both scholars and practitioners due to its flexibility. Comprising nine building blocks or quadrants, BMC was crafted by Alexander Osterwalder and Yves Pigneur to facilitate comprehensive business model analysis.

Notably, the business model's framework plays a pivotal role in developing and executing organizational strategies (Richardson, 2008). This study concentrates on formulating a sustainable digital BMC for the tourism and hospitality sector.

The research scrutinizes the application of the BMC, as conceptualized by Osterwalder and Pigneur (2010), within Hotel Leisure Group, examining its compatibility with international hotel reservation systems Agoda and Booking.com.

Within the BMC framework, customer segments encompass different organizational groups targeted by the company for service. Customers are the lifeblood of enterprises (Osterwalder & Pigneur, 2010), underscoring the significance of customer segments in aligning product specifications with needs.

Among market models, the multi-sided market stands out, accommodating companies with multiple customer segments interdependent on one another. This model requires satisfying the demands of diverse segments, exemplified by newspapers offering free copies to readers while relying on advertisements for financing (Osterwalder & Pigneur, 2010).

The Value Proposition block encompasses products and services generating value for the Customer Segment. A company's value proposition underpins customer purchasing decisions, addressing their problems and desires. Value propositions tailor offerings to specific customer segments, which can entail innovation or augmentation of existing offerings (Osterwalder & Pigneur, 2010).

## METHODOLOGY

The Business Model Concept and Business Model Canvas (BMC) theoretical framework, conceived for business management, have gained prominence since the 1990s. This framework, applied to internet services and digital businesses, describes the blueprint adopted by businesses for internal and external value creation (Zott, Amit, & Massa, 2011). Teece (2010) defines a business model as an internal and external framework for comprehending and producing stakeholder value. It serves as a conduit for delivering customer needs and monetizing them into enterprise returns and profits. Three perspectives—value creation, value proposition, and value capture—form the basis for business growth within this framework.

Debates persist within the literature, addressing the absence of a universally accepted global definition that integrates business model elements (Shafer, Smith, & Linder, 2005). The discourse also delves into whether business models are static or dynamic (Demil & Lecocq, 2010). The business model's role in representing and developing strategic choices to foster enterprise and customer value is significant (Shafer et al., 2005). The Business Model Canvas (BMC) is a versatile tool adopted by both scholars and practitioners due to its flexibility. Comprising nine building blocks or quadrants, BMC was crafted by Alexander Osterwalder and Yves Pigneur to facilitate comprehensive business model analysis.

The forthcoming research dissertation adopts the nine building block questions of the business model formulated by Osterwalder and Pigneur (2010). Notably, the business model's framework plays a pivotal role in developing and executing organizational strategies (Richardson, 2008). This paper concentrates on formulating a sustainable digital BMC for the tourism and hospitality sector. The research scrutinizes the application of the BMC, as conceptualized by Osterwalder and Pigneur (2010), examining its compatibility with international hotel reservation systems, such as Agoda, Expedia, and Booking.com.

The forthcoming conference paper adopts the nine building block criteria formulated by Osterwalder and Pigneur (2010):

- 1) Key Partners: Identify customers and vendors and their contributions to goal attainment.
- 2) Key Activities: Outline primary business activities for realizing value propositions.
- 3) Key Resources: Identify essential assets for value creation and business sustainability.
- 4) Value Propositions: Define value propositions (goods and services) aligning with customer needs.
- 5) Customer Segments: Analyze existing and potential market segments.
- 6) Channels: Determine avenues for product and service delivery to customers.
- 7) Customer Relationships: Expound on acquiring and retaining customers, fostering revenue growth.
- 8) Cost Structure: Outline primary cost elements of the enterprise.
- 9) Revenue Streams: Identify revenue sources.

## FINDINGS AND DISCUSSION

### **Analysis of Agoda Platform's E-business Model in Hospitality Management**

In recent years, the remarkable competition common among hotel booking firms, with Agoda standing out as a key participant, can be ascribed in part to Agoda's amazing growth trajectory. Agoda began as an e-commerce firm in Singapore in 2005 and

quickly grew into one of the world's fastest-expanding online travel booking platforms. Currently, the corporation has the status of an international conglomerate, with a vast network that includes an astounding assortment of 2 million properties spread across more than 200 nations worldwide. Zentner, 2022).

Within the context of hospitality management, the e-business model adopted by Agoda introduces several distinctive features and strategies that contribute to its success. One of these strategies is the Agoda Growth Program (AGP), a comprehensive marketing initiative tailored to enhance visibility, production, and revenue for partner hotels within the Agoda platform and beyond. Additionally, Agoda presents customers with two distinct options for settling their accommodation expenses: the Agency Model and the Merchant Model. Under the Agency Model, customers directly remit payment to hotels for



accommodations, while the Merchant Model allows accommodation costs to be incorporated into comprehensive travel packages. While accommodations under the Merchant Model may appear discounted, Agoda maintains predetermined income margins. To stimulate bookings, Agoda employs promotional offers, catering to the ongoing demand for valuable and efficient services. This commitment to consistent, high-quality service not only fosters customer satisfaction but also nurtures enduring supplier-customer relationships. As trust and contentment grow, these relationships solidify, particularly in the presence of reliable service delivery. Agoda's reputation rests on its unwavering dedication to impeccable service and its proactive approach to addressing any lapses, ensuring customer needs are met. Consequently, Agoda emerges as the preferred choice for novice Filipino travelers seeking trustworthiness and familiarity (Decena, 2022).

Agoda's stance as an innovation pioneer extends beyond its e-business model to encompass its leadership and organizational structure. Recognizing the inevitability of challenges, Agoda acknowledges its limited expertise in crucial areas, especially technology and digital transformation. To counter these limitations, Agoda embarks on a restructuring journey, harnessing the potential of Artificial Intelligence (AI) and machine learning advancements. Although Agoda's backend processes exhibit technological integration, untapped opportunities remain to maximize technology for frontend operations. The design of Agoda's website, while compact, may overwhelm users and potentially lead to transactional errors or frustration. This aspect, while significant, underscores the need for technical and financial resources to support continuous improvement and the alignment of customer expectations. Concurrently, Agoda grapples with inefficient inventory and cash-flow management, revealing a disparity between backend technological integration and these operational challenges (Decena, 2022).

To address these intricacies and challenges, Agoda is poised to capitalize on strategic adjustments. With web design constantly evolving in alignment with graphic design trends, Agoda can elevate the aesthetics and structure of its web content and design, enhancing user experience. Introducing flexibility in customer options, encompassing diverse package inclusions, price ranges, a broader spectrum of hotel accommodations, and transportation services, can amplify customer engagement. Moreover, Agoda can explore offering customers the ability to customize accommodations by integrating activities and transportation providers. Incorporating a cancellation option with an appropriate penalty fee can further enhance the customer journey. Diverse promotions, discounts, and complimentary offerings can effectively capture and retain customer interest, propelling Agoda's continued success (Decena, 2022).

**Business Model Concept and Business Model Canvas of Agoda**

In examining Agoda's business model, we turn to the nine building block questions as formulated by the Business Model Canvas framework, as Table 1 below.

Table 1. Business Model Canvas of Agoda

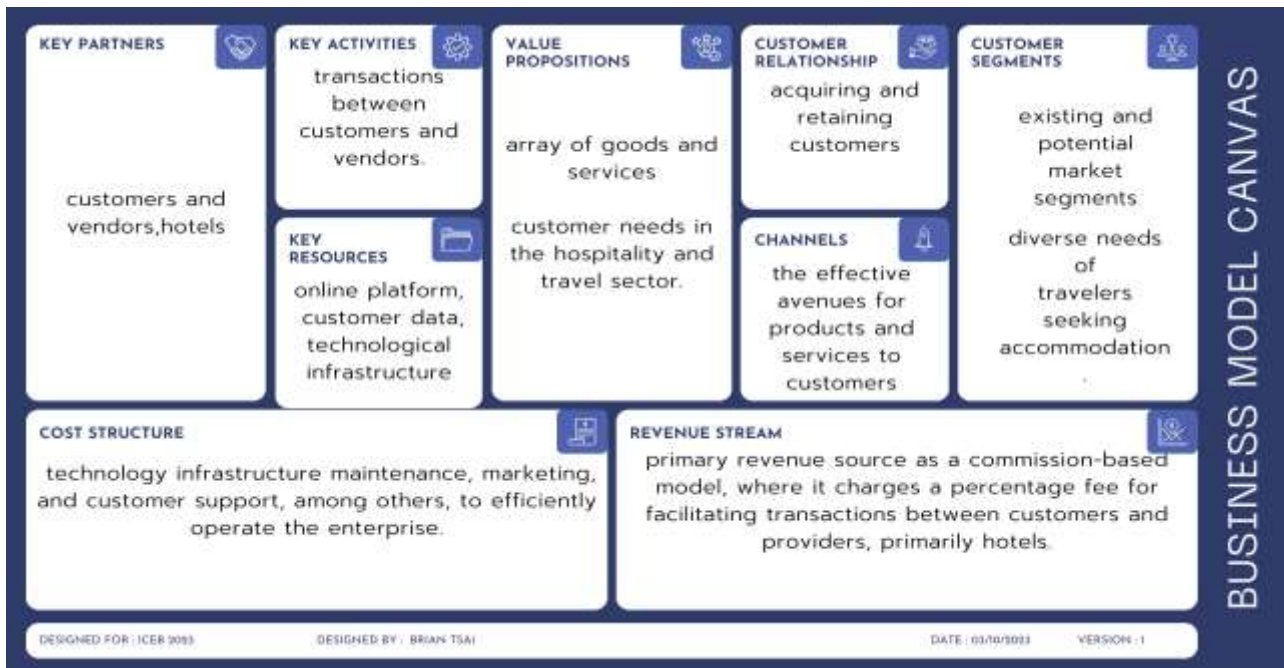

Source: This study.

**Key Partners:** Agoda identifies its primary collaborators as customers and vendors, each playing a crucial role in achieving its objectives. Customers seek accommodation, while vendors, such as hotels, contribute to the platform's mission by providing lodging options.

**Key Activities:** Agoda outlines its primary business activities as the facilitation of transactions between customers and vendors. These activities are geared towards realizing value propositions.



**Key Resources:** Essential assets, including a robust online platform, customer data, and technological infrastructure, form the foundation for Agoda's value creation and long-term sustainability.

**Value Propositions:** Agoda defines its value propositions as the array of goods and services it offers, meticulously aligned with customer needs in the hospitality and travel sector.

**Customer Segments:** Agoda diligently analyzes both existing and potential market segments to cater to the diverse needs of travelers seeking accommodation.

**Channels:** Agoda determines the most effective avenues for delivering its products and services to customers, optimizing user experience.

**Customer Relationships:** Agoda places great importance on acquiring and retaining customers, as it is essential for fostering revenue growth and sustaining its marketplace model.

**Cost Structure:** Agoda outlines its primary cost elements, which include technology infrastructure maintenance, marketing, and customer support, among others, to efficiently operate the enterprise.

**Revenue Streams:** Agoda identifies its primary revenue source as a commission-based model, where it charges a percentage fee for facilitating transactions between customers and providers, primarily hotels.

Agoda operates within the competitive realm of Online Travel Agencies (OTAs) and predominantly employs a commission-based marketplace business model. Under this model, Agoda charges a commission for each transaction facilitated through its platform. When a customer pays for a reservation, Agoda manages the payment process and deducts a percentage fee.

The key challenge in this marketplace model lies in delivering value to both customers and providers, notably hotels. Agoda must ensure that customers perceive value in using its platform, or they might choose to book directly with hotels. Conversely, if hotels do not derive value from listing their offerings on Agoda, they may opt for independent operations. This challenge underscores a limitation within Agoda's business model.

In the OTA industry, three primary business models are prevalent: advertising, agency, and the marketplace model. While these distinctions might seem complex, OTAs fundamentally serve as aggregation platforms. They thrive in highly fragmented industries where numerous companies compete, and no single entity dominates. A deeper exploration of these models and their implications will be presented in the subsequent section on competitors.

Agoda's revenue generation relies exclusively on the marketplace business model. In essence, Agoda functions as a third-party intermediary, reselling travel accommodations such as hotel rooms, vacation packages, and more. Guests make payments to Agoda at the time of booking, and Agoda subsequently settles with the hotels after the guest's stay is completed. To illustrate, consider the following example of the marketplace business model in action: Agoda procures hotel rooms and subsequently offers them to travelers, managing the transaction process.

### **Analysis of Expedia Platform's E-business Model in Hospitality Management**

The investigation into e-business models within the realm of hospitality management unveils a comparative scrutiny of prominent hotel reservation systems, involving Booking.com, Expedia, and Agoda. This study aims to dissect the intricate dimensions of these platforms' operational frameworks, shedding light on their distinct characteristics and strategic approaches.

When scrutinizing the Business Model Canvas (BMC) of Expedia, it becomes evident that the foundation of its operational structure lies within a linear value chain. This configuration is characterized by suppliers and providers of tourist services on the input side, from whom Expedia procures capacities at favorable wholesale prices. On the opposite end of the spectrum, tourists engage with Expedia to procure tourist products or packages at retail prices. Despite Expedia's digital nature, facilitated by online communication and sales channels, and its robust technological infrastructure, its business model is reminiscent of traditional models embraced by tourism intermediaries. It is worth noting that this linear value chain has, over time, demonstrated limitations in Expedia's expansion trajectory, particularly when compared to its primary competitor,

Booking.com. The latter has embraced a more scalable and versatile two-sided platform business model, propelling it to an advantageous position (Zentner, 2022).

In summary, this investigation delves into the intricate e-business models employed in hospitality management, with specific focus on Booking.com, Expedia, and Agoda. The analysis endeavors to uncover the strategic nuances that differentiate these platforms, offering valuable insights into their approaches to digital business in the realm of hotel reservation systems.

### **Business Model Concept and Business Model Canvas of Expedia**

In this analysis of Expedia's business model, we employ the nine building block questions as delineated by the Business Model Canvas framework, as Table 2 below.

Table 2: Business Model Canvas of Expedia



Source: This study.

**Key Partners:** Expedia identifies its primary partners as customers and vendors, recognizing their significant contributions to the achievement of its objectives. Customers seek travel services, while vendors, such as airlines, hotels, car rental companies, and other travel providers, play a pivotal role in fulfilling travel bookings.

**Key Activities:** Expedia outlines its primary business activities, which revolve around realizing its value propositions. These activities encompass technological platform development, partnership negotiations with travel providers, pricing and inventory management, as well as customer acquisition and retention strategies.

**Key Resources:** Essential assets, including a robust technology infrastructure, data analytics capabilities, strategic partnerships, and a strong brand reputation, are pivotal for Expedia's ability to create value and sustain its business over time.

**Value Propositions:** Expedia defines its value propositions by offering travelers the convenience of accessing a wide range of travel options, loyalty programs, and facilitating the growth of other travel companies. Additionally, Expedia's platform attracts increased customer traffic and revenue for its partners.

**Customer Segments:** Expedia meticulously analyzes both existing and potential market segments to cater to the diverse needs of leisure and business travelers seeking travel services and experience.

**Channels:** Expedia determines the most effective channels for delivering its products and services to customers, encompassing its website, mobile app, partnerships with other travel companies, search engine optimization, and online advertising.

**Customer Relationships:** Expedia nurtures customer relationships through email marketing, social media engagement, responsive customer support, and user-generated content and reviews. These relationships are instrumental in acquiring, retaining, and fostering revenue growth from customers.

**Cost Structure:** Expedia outlines its primary cost elements, which include technology development and maintenance, marketing and advertising, employee salaries and benefits, partnerships with travel providers, and customer support and payment processing, to operate the enterprise efficiently.

**Revenue Streams:** Expedia identifies its primary revenue sources, which include reselling travel packages, commission fees on bookings, and advertising. These revenue streams form the core of its financial sustainability.

Expedia has been a trailblazer in the online travel industry for over 25 years. Its business model, centered around providing a comprehensive travel platform where travelers can seamlessly search and book flights, hotels, and other travel reservations, has been instrumental in its success. By aggregating travel options in one place, Expedia encourages many travelers to use its platform for convenient travel booking. Expedia's proprietary technology platform is a key resource, enabling user-friendly online booking and reservation management. The company's dedication to technology has allowed it to continually enhance the user experience and offer innovative products and services. Recent updates focusing on working with consumers throughout their trips, rather than solely on booking volume, underscore Expedia's commitment to delivering a personalized travel experience. While competition from other online travel agencies and travel search engines exists, Expedia's strong brand recognition, vast inventory of travel options, and emphasis on technology confer a competitive edge. Expedia's ability to adapt to evolving consumer preferences and travel trends will be pivotal to its sustained success in the future.

### **Analysis of Booking.com Platform's E-business Model in Hospitality Management**

Booking.com distinguishes itself through the adept implementation of the Agency model, facilitating direct customer transactions with hotels, ensuring transparency, and eliminating additional costs. The presentation of prices for the entire stay rather than per day contributes to customer clarity and prevents misinterpretation. A notable feature, the Genius program, serves as a strategic incentive for business partners, offering amplified visibility on the Booking website, alongside guaranteed upgrades and breakfast perks. The company's ability to navigate a regulated business landscape is underscored by its establishment of robust connections with lobby groups and political networks, enabling adherence to regulations. Booking.com's portfolio encompasses a wide array of accommodation choices, granting customers diverse options spanning prices and accommodation types. These attributes have solidified Booking.com as a preferred choice for both domestic and international travelers, firmly establishing its reputation (Decena, 2022).

However, Booking.com confronts substantial challenges, particularly in the realm of technology and digital transformation. In a parallel trajectory with Agoda, Booking.com initiates procedural reconfiguration to leverage the potential of artificial intelligence (AI) and machine learning advancements. Respondents have pointed to a cluttered web design on Booking.com, potentially causing information overload and confusion for users. Despite the existence of numerous patents and copyrights, Booking.com's replicable business model lacks the adaptability and malleability required to withstand imitation by competitors. The company's internal focus on delivery-centric project management may inadvertently sideline external stakeholder interests, potentially harming its public image and customer relationships (Decena, 2022).

In response to these imperatives, Booking.com has the opportunity to align its approach with the evolving trends of web design, facilitating a more user-friendly experience through a streamlined interface. Expanding the reach of the Genius program to untapped partners within the Philippines can foster increased promotional offers and discounts, enhancing customer engagement. The integration of novel payment options, such as nationality-based bank transfers, aligns seamlessly with Booking.com's strategic embrace of AI and machine learning. Comparable to Agoda, Booking.com is confronted by external threats, including competition from alternative online booking platforms and the fluctuation of hotel rental prices, all of which pose challenges to the platform's sustainability. Additionally, the prevailing travel restrictions pose a formidable challenge to Booking.com's continued success. As the landscape evolves, Booking.com must capitalize on its strengths, tackle challenges proactively, and seize opportunities to sustain its standing as a frontrunner in the hospitality management domain (Decena, 2022).

### **Business Model Concept and Business Model Canvas of Booking.com**

In this examination of Booking.com's business model, we apply the nine building block questions as defined by the Business Model Canvas framework, as Table 3.

**Key Partners:** Booking.com identifies its primary partners as both customers and vendors, recognizing their integral roles in achieving the company's objectives. Customers seek accommodations, while hotels and lodging providers contribute significantly to Booking.com's goals.

**Key Activities:** Booking.com outlines its primary business activities, which are aimed at realizing its value propositions. These activities primarily involve facilitating the booking process between customers and hotels.

**Key Resources:** Essential assets such as its online platform, vast customer data, and technological infrastructure are identified as fundamental resources that enable Booking.com to create value and maintain business sustainability.

**Value Propositions:** Booking.com defines its value propositions by offering a range of goods and services meticulously aligned with the diverse needs of customers and hotels within the hospitality industry.

**Customer Segments:** Booking.com meticulously analyzes both existing and potential market segments to cater to the diverse requirements of travelers seeking accommodations and hotels looking to fill their rooms.

**Channels:** Booking.com determines the most effective channels for delivering its products and services to customers, emphasizing the optimization of user experience and accessibility.

**Customer Relationships:** Booking.com places significant emphasis on acquiring and retaining customers, recognizing the pivotal role this plays in fostering revenue growth and sustaining its marketplace model.

**Cost Structure:** Booking.com outlines its primary cost elements, including technology infrastructure maintenance, marketing, and customer support, among others, to ensure the efficient operation of the enterprise.

**Revenue Streams:** Booking.com identifies its primary revenue sources, which predominantly stem from commissions earned through facilitating transactions between customers and hotels, particularly in the context of room reservations.

Table 3: Business Model Canvas of Booking.com

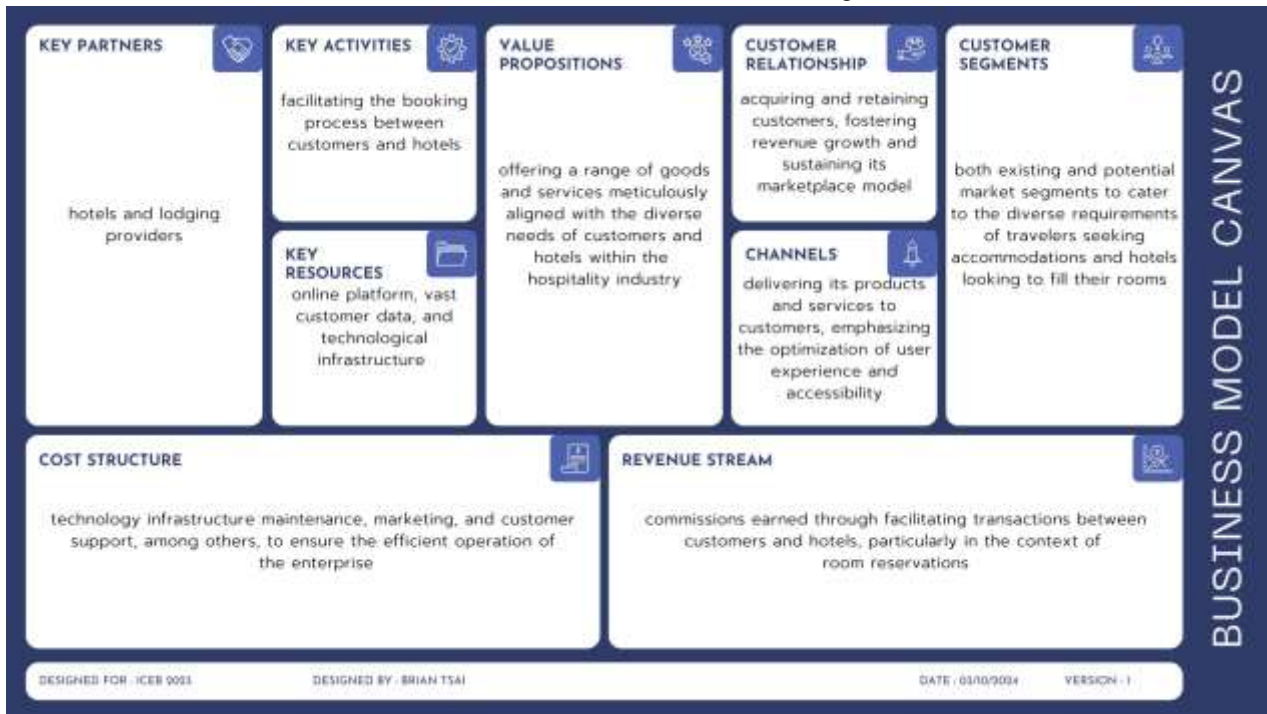

Source: This study.

### The Analysis of E-business Models of Booking.com, Expedia and Agoda

While comparing Booking.com, Expedia and Agoda, despite all being hotel reservation systems with demand aggregator platforms, there are notable differences. A key distinction lies in their geographic exposure. Expedia primarily caters to customers in the United States, generating most of its revenue from this region. On the other hand, Booking.com operates mainly in Europe, while Agoda's focus is predominantly in Asia. Another differentiation is observed in the adoption of single or multi-brand approaches. Expedia's structure comprises various website properties acquired over time, including Hotels.com and Travelocity. In contrast, Booking Holdings and Agoda generate a significant portion of their revenue from their main website platforms. Over the long term, this divergence in strategy might influence Expedia's online business trajectory. Having a unified website strategy can lead to a larger market share, as demonstrated by Booking.com and Agoda, with a substantial portion of their traffic originating directly from users. Consequently, Booking and Agoda's website strategy is more effective (Lo, 2021).

Agoda addresses the challenge of hotels losing customers due to user-unfriendly booking platforms and travelers seeking better deals without the complexity of comparing individual hotel bookings. Thus, Agoda's mission is to facilitate easy and affordable hotel bookings in Asia for global customers, providing value and a user-friendly experience. Agoda and other hotel reservation systems provide a market-driven solution by offering a platform for both hotels and customers to engage. Agoda's platform lists available hotels based on customer requirements, directly connecting customers with hotels. This transparent information empowers customers to make informed choices. Simultaneously, hotels benefit from increased customer reach, particularly independent ones. Agoda employs a marketplace model, allowing it to acquire hotel rooms in bulk and offer competitive prices. Additionally, 'The Illusion of Choice' or 'self-competition' strategy is implemented by Agoda and Booking.com. This strategy creates the perception of price competition between these platforms, though ultimately both are under Booking Holdings, maximizing revenue for the parent company (Lo, 2021).

For instance, the estimation of the Malaysian hotel booking hotel reservation industry's market size involves multiplying the number of available hotel rooms by the total revenue per room, assuming a 15% commission. The calculation includes the total number of available rooms per day, the total revenue per room, and the assumption that rooms are booked for 70% of the year. By multiplying these values, the market size is derived. Agoda is recognized as highly profitable, particularly in the Asian

context. This profitability stems from its marketplace business model, where low costs contribute to sustaining healthy revenue and profit margins. Even during periods of slower revenue growth, Agoda's ability to adjust marketing expenses enables maintaining profitability. Agoda's scalability is notable due to its marketplace model, which keeps labor costs low and focuses on marketing. Expansion relies on customer acquisition and reaching new geographical regions. Agoda's growth potential is tied to both economic conditions and its ability to expand to new markets (Lo, 2021).

Agoda is a reputable booking site, known for its user-friendly experience and attractive cancellation policies. The company's management team boasts extensive experience, ensuring the company's success. Its brilliant leadership plays a crucial role in Agoda's growth. Agoda was founded by Michael Kenny and Robert Rosenstein in 2005, and it was acquired by Booking Holdings in 2007. While specific revenue figures are not provided, it's estimated that Agoda's revenue is substantial, given its position as one of the top-performing hotel reservation systems in Asia. Agoda exhibits strong startup traction with consistent growth in customers and revenue, despite the challenges posed by the COVID-19 pandemic. This growth showcases Agoda's ability to consistently meet benchmarks and maintain a solid sales channel over time (Lo, 2021).

### The Comparison of Business Model Canvas of Booking.com, Expedia, and Agoda

Table 4: The Comparison of Business Model Canvas of Booking.com, Expedia, and Agoda



Source: This study.

#### Key Partners

Booking.com: Customers and hotels are Booking.com's primary partners. They work closely with hotels to list their properties and offer accommodations to travelers.

Expedia: Customers and various travel providers such as airlines, hotels, and car rental companies are key partners for Expedia.

Agoda: Agoda also relies on customers and hotels as key partners, similar to Booking.com and Expedia.

#### Key Activities

Booking.com: Booking.com's main activities involve facilitating the booking process between customers and hotels. They focus on connecting travelers with suitable accommodations.

Expedia: Expedia engages in technological platform development, partnership negotiations, pricing and inventory management, and customer acquisition and retention strategies.

Agoda: Agoda primarily facilitates transactions between customers and hotels, aiming to provide value to both parties.

#### Key Resources

Booking.com: Key resources for Booking.com include its online platform, customer data, and technological infrastructure. Expedia: Expedia relies on a robust technology infrastructure, data analytics capabilities, strategic partnerships, and its strong brand reputation.

Agoda: Agoda also emphasizes its online platform, customer data, and technological infrastructure as essential resources.

#### Value Propositions



Booking.com: Booking.com's value proposition focuses on helping hotels fill vacant rooms efficiently, react to market dynamics, reach a global audience, reduce risk, drive additional website traffic, and provide market intelligence.

Expedia: Expedia offers travelers convenience, loyalty programs, and facilitates the growth of other travel companies while increasing customer traffic and revenue for its partners.

Agoda: Agoda aligns its value propositions with the needs of customers and hotels in the hospitality industry, ensuring a range of goods and services are offered.

### ***Customer Segments***

Booking.com: Booking.com targets both travelers seeking accommodations and hotels looking to fill their rooms. Expedia: Expedia caters to leisure and business travelers seeking various travel services and experiences.

Agoda: Agoda serves travelers seeking accommodation and hotels in the hospitality sector.

### ***Channels***

Booking.com: Booking.com focuses on optimizing the user experience and accessibility of its platform.

Expedia: Expedia utilizes various channels, including its website, mobile app, partnerships, SEO, and online advertising.

Agoda: Agoda also emphasizes optimizing user experience and effective product delivery channels.

### ***Customer Relationships***

Booking.com: Booking.com places significant importance on acquiring and retaining customers to foster revenue growth and sustain its marketplace model.

Expedia: Expedia nurtures customer relationships through email marketing, social media engagement, responsive customer support, and user-generated content.

Agoda: Agoda, like the others, values customer acquisition and retention to drive its revenue growth.

### ***Cost Structure***

Booking.com: Key cost elements for Booking.com include technology infrastructure maintenance, marketing, and customer support.

Expedia: Expedia's primary cost elements encompass technology development and maintenance, marketing and advertising, employee salaries, partnerships, and customer support.

Agoda: Agoda's cost structure includes technology infrastructure maintenance, marketing, and customer support, similar to Booking.com and Expedia.

### ***Revenue Streams***

Booking.com: Booking.com primarily earns revenue through commissions from facilitating transactions between customers and hotels.

Expedia: Expedia generates revenue through reselling travel packages, commission fees, and advertising.

Agoda: Agoda's primary revenue source is a commission-based model, charging a percentage fee for facilitating transactions between customers and hotels.

In summary, Booking.com, Expedia, and Agoda share several similarities in their business models, as they all operate within the online travel agency industry. They connect travelers with accommodations, earn revenue through commissions, and prioritize customer acquisition and retention. However, each platform has its unique value propositions and strategies to differentiate itself in the competitive market. Booking.com, for example, focuses on helping hotels optimize their revenue and provides market intelligence, while Expedia emphasizes convenience and partnerships with travel providers. Agoda, on the other hand, aims to align its offerings with the specific needs of its customer and hotel segments.

## **CONCLUSION AND IMPLICATIONS**

In the rapidly evolving landscape of hospitality management, e-business models have ushered in transformative changes, reshaping the way hotels and travelers interact. This paper conducted an in-depth exploration of the e-business models in the context of hotel reservation systems, focusing on three prominent platforms: Booking.com, Expedia, and Agoda. Through a rigorous comparative analysis, this research unraveled the intricacies of these platforms, shedding light on their operational frameworks, market positioning, and strategies for customer engagement.

The findings of this study revealed nuanced differences in the e-business models adopted by Booking.com, Expedia, and Agoda. While all three platforms offer essential booking functionalities, their strategies for expansion, partnership networks, and customer loyalty initiatives diverge significantly. The study also highlighted variations in the success of building customer trust and engagement, providing insights into the factors influencing users' preferences for specific platforms.

The implications of this research extend to both academia and industry professionals. For scholars, this study enriches the understanding of e-business models within the hospitality sector, offering insights into the distinctive strategies of Booking.com, Expedia, and Agoda. The comparative analysis provides a comprehensive view of their approaches, aiding future research on digital business models and their impact on the hospitality industry.

For industry professionals, this research serves as a strategic guide. The analysis of these platforms' strengths, challenges, and opportunities offers practical insights that can inform decision-making. By comprehending the operational dynamics and strategies of Booking.com, Expedia, and Agoda, stakeholders in the hospitality industry can navigate the evolving landscape more effectively. As e-business models continue to shape the hospitality sector, this research provides a foundation for adapting to technological advancements, meeting customer expectations, and remaining competitive.

By way of conclusion, the paper has explored the innovative e-business models for hotel reservation systems in hospitality management. The research of e-business models in hospitality management, as exemplified by Booking.com, Expedia, and Agoda, holds significance for understanding the intricate interplay between technology, customer engagement, and business strategies. This research contributes to the ongoing dialogue on digital transformation in the hospitality industry and paves the way for future explorations and adaptations in this dynamic and evolving landscape.

## REFERENCES

- Bilbil, E. T. (2018). Platform Cooperation in the Tourism Industry: Conflicts and Tensions Caused by the Closure of Booking.Com in Turkey. *Current Issues In Tourism*, 22(6), 1-21.
- Brousseau, E., & Penard, T. (2007). The Economics of Digital Business Models: A Framework for Analyzing the Economics of Platforms. *Review of Network Economics*, 6(2), 81-114.
- Buranyi. (2020). The WHO v Coronavirus: Why It Can't Handle the Pandemic. *The Guardian*. Retrieved from <https://www.theguardian.com/news/2020/apr/10/World-health-organization-who-vcoronavirus-why-it-canthandle-pandemic>
- Cohen, E. (1979). Rethinking the Sociology of Tourism. *Annals of Tourism Research*, 6(1), 18-35.
- Crnojevac, I. H., Gugić, J., & Karlovačan, S. (2010). eTourism: A Comparison of Online and Offline Bookings and the Importance of Hotel Attributes. *Journal of Information and Organizational Sciences*, 34(1).
- Decena, K. E. F., & Delfin, M. G. (2022). Factors Affecting the Usage of Online Booking Sites: Comparative Analysis on Agoda, Booking, and Hotels. *Proceedings of the 7th North American International Conference on Industrial Engineering and Operations Management*, Orlando, Florida, USA.
- Demil, B., & Lecocq, X. (2010). Business Model Evolution: In Search of Dynamic Consistency. *Long Range Planning*, 43(2/3), 227-246.
- Denzin, N. K., & Lincoln, Y. S. (2017). *The Sage Handbook of Qualitative Research*. Sage Publications.
- Dutta, S., Chauhan, R. K., & Chauhan, K. (2017). Factors Affecting Customer Satisfaction of Online Travel Agencies in India. *Tourism and Hospitality Management*, 23(2), 267-277.
- Elliot, S., & Joppe, M. (2010). Packaging Travel on the Web: A Case Study of Ottawa Tourism. *Travel Tour*.
- Fielt, E. (2014). Conceptualising Business Models: Definitions, Frameworks and Classifications. *Journal of Business Models*, 1(1), 85-105.
- Gossling, S., Scott, D., & Hall, C. M. (2020). Pandemics, Tourism and Global Change: A Rapid Assessment of COVID-19. *Journal of Sustainable Tourism*.
- Guba, E. G., & Lincoln, Y. S. (1994). Competing Paradigms in Qualitative Research. In N. K. Denzin & Y. S. Lincoln (Eds.), *Handbook of qualitative research* (pp. 163-194). SAGE Publications.
- Guba, E. G., Lincoln, Y. S., & Denzin, N. K. (1994). *Handbook of Qualitative Research*. SAGE Publications, 105-117.
- Guest, G. (2013). Describing Mixed Methods Research: An Alternative to Typologies. *Journal of Mixed Methods Research*, 7(2), 141-151.
- Härting, R.-C., Reichstein, C., & Schad, M. (2018). Potentials of Digital Business Models—Empirical Investigation of Data Driven Impacts in Industry. *Procedia Computer Science*, 126, 1495-1506.
- Jensen, J. M., & Wagner, C. (2018). A Cross-National Comparison of Millennial Consumers' Initial Trust Towards an E-Travel Website. *Marketing Intelligence & Planning*, 36(2).
- Karlsson, M., & Le Huong, T. (2017). A Review of the Kano Model, A Case Study of Online Travel Agencies. *Student Thesis, Halmstad University, School of Business, Engineering and Science, Halmstad, Sweden*.
- Kivunja, C., & Kuyini, A. B. (2017). Understanding and Applying Research Paradigms in Educational Contexts. *International Journal of Higher Education*, 6(5), 26-41.
- Köhler, T., Smith, A., & Bhakoo, V. (2018). Feature Topic for ORM: "Templates in Qualitative Research Methods". *Organizational Research Methods*, 22(1), 3-5.
- Kuhn, T. S. (2012). *The Structure of Scientific Revolutions: University of Chicago Press*.
- Lo, Y. S. (2021, June 29). Agoda Business Model — NEXEA. NEXEA. <https://www.nexea.co/agoda-business-model/>
- Massa, L., Tucci, C. L., & Afuah, A. (2017). A Critical Assessment of Business Model Research. *Academy of Management Annals*, 11(1), 73-104.
- Mihajlović, I., & Strugar, I. (2015). Revisiting the Impact of ICT to the Tourism Development. *Society for Advancing Innovation and Research in Economy*, 524-532.
- Morgan, D. L. (2007). Paradigms Lost and Pragmatism Regained: Methodological Implications of Combining Qualitative and Quantitative Methods. *Journal of Mixed Methods Research*, 1(1), 48-76.
- Morgunov, A. (2021). How to Create a Business Model Canvas for Online Marketplace. Retrieved from <https://sloboda-studio.com/blog/business-model-Canvas-online-marketplace/>
- Morse, J. M., & Niehaus, L. (2009). *Mixed Methods Design*. Walnut Creek: Left Coast Press.



- Muzellec, L., Ronteau, S., & Lambkin, M. (2015). Two-Sided Internet Platforms: A Business Model Lifecycle Perspective. *Industrial Marketing Management*, 45, 139-150.
- Osterwalder, A., Pigneur, Y., & Clark, T. (2010). *Business Model generation: A Handbook for Visionaries, Game Changers, and Challengers*. Hoboken, NJ: Wiley.
- Osterwalder, A. (2004). The Business Model Ontology: A Proposition in a Design Science Approach. *Ph.D. Thesis, University of Lausanne, Lausanne, Switzerland*.
- Remane, G., Hanelt, A., Nickerson, R. C., & Kolbe, L. M. (2017). Discovering Digital Business Models in Traditional Industries. *Journal of Business Strategy*, 38(2).
- Reinhold, S., Zach, F. J., & Krizaj, D. (2017). Business Models in Tourism: A Review and Research Agenda. *Tourism Review*, 72(6).
- Richardson, J. (2008). The business model: An Integrative Framework for strategy Execution. *Strategy Change*, 17, 133-144.
- Ruiz-Gómez, L. M., Navío-Marco, J., & Rodríguez-Hevíá, L. F. (2018). Dynamics of Digital Tourism's Consumers in the EU, 20, 59–81.
- Shafer, S. M., Smith, H. J., & Linder, J. C. (2005). The Power of Business Models. *Business Horizons*, 48(3), 199-207.
- Shaughnessy, H. (2016). Harnessing Platform-Based Business Models to Power Disruptive Innovation. *Strategy and Leadership*, 44(5), 6-14.
- Simmons, D. (1985). Integrating Formal and Informal Research Methods. In: *Issues in Tourism Research in the South Pacific. Proceedings of the Meeting of the Sub-commission on Tourism in the South West Pacific, Christchurch, 23-25 January, 1983*.
- Sjekavica, T., Žitnik, M., & Miličević, M. (2017). A Novelty Model of Online Accommodation Presentation and Discovery.
- Teddlie, C., & Tashakkori, A. (2009). *Foundations of Mixed Methods Research: Integrating Quantitative and Qualitative approaches in the social and Behavioral Sciences*. Sage Publications.
- Teece, D. J. (2010). Business Models, Business Strategy and Innovation. *Long Range Planning*, 43(2/3), 172–194.
- Voigt, D.-W. S., & Hinz, O. (2015). Making Digital Freemium Business Models a Success: Predicting Customers' Lifetime Value via Initial Purchase Information. *Business & Information Systems Engineering*, 58(2).
- Weill, P., & Woerner, S. L. (2013). Optimizing Your Digital Business Model. *MIS Quarterly Executive*, 54, 71–78.
- Yin, R. K. (2009). *Case Study Research: Design and Methods (4th ed.)*. Sage Publications.
- Zentner, H., Gračan, D., & Barkidija Sotošek, M. (2022). Digital Business Models in the Hospitality Sector: Comparing Hotel Bookings with Yacht Charter Bookings. *Sustainability*.
- Zott, C., Amit, R., & Massa, L. (2011). The Business Model: Recent Developments and Future Research. *Journal of Management*, 37, 1019–1042.

# The Technologies of Digital Supply Chain in Industry 4.0: The Principles of Internet of Things, Big Data, Blockchain, and Digital Supply Chain Twin and Their Challenges

Shih-Jung Juan<sup>1,\*</sup>

\*Corresponding author

<sup>1</sup> Ph.D., National Chengchi University, Taipei, Taiwan, [104356505@nccu.edu.tw](mailto:104356505@nccu.edu.tw)

## ABSTRACT

Industry 4.0 represents the fourth industrial revolution and is the digital transformation of smart manufacturing and industrial markets. In the Industry 4.0 era, emerging technologies such as the Internet of Things (IoT), cloud computing, big data, blockchain, 5G, and digital twins have arisen rapidly. Most of them are utilized in supply chain management processes, leading to the rise of digital supply chains. The most widely used technology is IoT. The most common applications are the technologies combined with IoT, cloud computing, and big data analysis. Blockchain is a developing technology, while the digital supply chain twins are an integrated technology encompassing simulation. Thus, this review focuses on these four critical technologies (i.e., IoT, big data, blockchain, and digital supply chain twins) to explore their principles, applications, and possible challenges in the digital supply chain. In addition, this review also compares the difference between digital supply chains and smart supply chains and explains their relationship.

*Keywords:* Digital supply chain, smart supply chain, Internet of Things, big data, blockchain, digital supply chain twins.

## INTRODUCTION

Industry 4.0 is a popular topic nowadays. It was first introduced by a group of representatives from different fields under an initiative to enhance German competitiveness in the manufacturing industry in 2011 (Oztemel & Gursev, 2020). Next, the German federal government announced that Industry 4.0 would be integral to the “High Technology Strategy for German 2020”. Industry 4.0 is the digital transformation of industrial markets with smart manufacturing, which is currently at the forefront. It represents the fourth industrial revolution in discrete and process manufacturing, logistics, and supply chain (SC) (Misra *et al.*, 2022). Many researchers confirmed that Industry 4.0 bring benefits, such as manufacturing flexibility, product diversification, faster market responsiveness, shorter lead times, better capacity utilization, and others (e.g., Hofmann & Rusch, 2017). In the Industry 4.0 era, emerging technologies such as the Internet of Things (IoT), cloud computing, big data, blockchain, 5G, and digital twins have arisen rapidly. Most of them are utilized in the processes of supply chain management. Industry 4.0 represents a smart manufacturing networking concept where machines and products interact with each other without human control (Ivanov *et al.*, 2019). Ivanov *et al.* (2019) noted that Industry 4.0 technology enables new production strategies using cyber-physical system principles based on highly customized assembly systems with flexible manufacturing process design. Cyber-physical systems incorporate integrated elements from both information and material subsystems, and decisions in them are cohesive. SCs have been evolving eventually in such networks and systems with dynamic structures. Cyber-physical systems have led to the presence of digital SC in recent years. The related topics regarding digital SC have attracted academia and practitioners’ attention. Moreover, many of the technologies applied and converged in Industry 4.0 find their way into agriculture more than the manufacturing industry. Therefore, this review aims to explore the following research questions:

RQ1: to clarify the definition of digital supply chain and its relationship with smart supply chain;

RQ2: to identify the critical components of the digital supply chain, their principles, current applications, and possible challenges in the agriculture and food industry and related supply chain.

## THE DEFINITION OF DIGITAL SUPPLY CHAIN AND SMART SUPPLY CHAIN

Bhargava *et al.* (2013) state that a digital supply chain (DSC) is composed of those systems (e.g., software, hardware, communication networks) that support interactions between globally distributed organizations and orchestrate the activities of the partners in SCs. These activities include buying, making, storing, moving, and selling a product. Kinnet (2015) defined a DSC as a smart, value-driven network that leverages new approaches with novel technological and analytics to generate new revenue and business value for organizations.

Buyukozkan and Gocer (2018) concluded that the definition of DSC is an intelligent best-fit technological system that is based on the capability of big data analytics and excellent cooperation and communication for digital hardware, software, and networks to support and synchronize interaction between organizations by making services more valuable, accessible and affordable with

consistent, agile and effective results. Moreover, Buyukozkan and Gocer noted that DSC is about managing SC processes with various innovative technologies, e.g., unmanned aerial vehicles, cloud computing, and the Internet of Things.

Khan and Keramati (2023) noted that smart represents all human-centered digital technologies that combine intelligent and networked collaboration to improve the performance of the SC processes. The improved SC performance by all human-centered digital technologies is called smart SC. Khan and Keramati explained that digital technologies make technical systems intelligent and interconnected. Cyber-physical systems are engineered systems that communicate with each other to form the IoT and use big data and analytics to make well-informed local, autonomous decisions (Lee *et al.*, 2015). At the same time, smart organizations depend on similar digital technologies to integrate the system by connecting partners to extended value networks.

Smart SC is a flexible organization with the characteristics of customization on demand, process visualization, intelligent response, and a good early warning system, which can realize the fine sensitization of SC (Xu & Han, 2018). Smart SC is a system integrated with information technology and intelligent technology and management, with three characteristics: visualization, transparency, and collaboration (Huang *et al.*, 2018). The smart SC is a comprehensive, integrated technology and management system that integrates Things, Internet, technology, and modern SC management theory, method, and technology to realize the intelligent, networked, and automated business between enterprises (Zhao & Wang, 2014). Liu *et al.* (2022) concluded that the smart SC should be a system with more information symmetric and contacts in real time between SC members conveniently in information flow, logistics, capital flow, and others to improve the operational efficiency of SC. The biggest difference between the smart SC and traditional SC is that the smart SC takes the information network as the foundation of information transmission in SC. Every company can connect its system to the information system of the intelligent SC, ensuring the sharing of information and the high integration of information flow in the SC. Therefore, we realize that digital SC is the foundation of smart SC because digital SC provides the technical facet for smart SC. In contrast, smart SC regards the upper benefits of digital application.

### **A Smart Supply Chain Framework**

Zhang *et al.* (2023) defined a smart supply chain as integrating the partners, self-organizing and automatically adapting to environmental changes, and making intelligent decisions that best achieve business goals. Wu *et al.* (2016) defined a smart supply chain as the new interconnected business system which extends from isolated, local, and single-company applications to SC-wide systematic smart implementations. Zhang *et al.* (2023) follow the definition of smart SC to present a multi-level smart SC framework. There are four levels to reflect different stages and scopes of SC management with information communication technology (ICT), artificial intelligence (AI) & machine learning (ML), and other technologies.

Level 0 consists of smart technologies or drivers which provide the basis of smart supply chains, including ICT, AI & ML, and other technologies. ICT includes IoT, big data, cloud, blockchain, 3D printing, and others. AI&ML means artificial intelligence, machine learning, optimization, etc. The other technologies include advanced manufacturing, robotics, digit-twin, intelligent transportation, drone, supply chain finance and banking 4.0, and so on.

Level 1 is the initial stage of the smart supply chain, which applies the ICT/AI to improve a single function within the supply chain, that is, smart flow, i.e., material, information, finance with smart drivers, e.g., pricing, inventory, transportation, facility, sourcing to make smart strategy, tactics, and operations decision, for example, smart logistics, intelligent inventory management system, etc. The characteristics of this level are visibility, real-time, and optimization.

Level 2 represents the whole supply chain partners connected to implement intelligent decisions of all levels (i.e., operational, tactical, or strategic) in all flows (i.e., material, information, finance). The characteristics of this smart SC level are interconnected, intelligent, and self-organizing. They can reconfigure and self-optimize the network in response to environmental change and changes in business goals. Therefore, it can demonstrate superior performance in all key aspects, including responsiveness, efficiency, resilience, flexibility, and sustainability.

Level 3 is the smart business/system/industry that SC supports, such as smart automotive manufacturing under Industry 4.0, smart retailing, smart healthcare service, and even smart city to match business strategy, facilitate the implementation of Industry 4.0, and ultimately achieve the economic, environmental and social goals.

## **THE INVOLVED TECHNOLOGIES, THEIR APPLICATION, AND CHALLENGES OF THE DIGITAL SUPPLY CHAIN**

Smart SC uses innovative tools to enhance quality, improve performance, and facilitate decision-making (Nozari *et al.*, 2021). Khan and Keramati (2023) presented the technologies used in the smart SC, including big data analysis, Internet of Things (IoT), social media, user interface, robotics, 3D printing, blockchain, augmented reality, GPS, RFID, simulation, cyber-physical system, cybersecurity system, cloud computing. Zhang *et al.* (2023) reviewed the extant literature on ICT technologies under Industry 4.0 of smart SC management, and they suggested that future researchers can respectively explore the related issues of smart SC with the specific technology. Thus, we discuss the principle of the critical technologies regarding the smart SC with IoT, big data

& IoT, blockchain, and digital SC twin.

## Internet of Things

The term ‘Internet of Things’ (IoT) was coined by Kevin Ashton in 1999 concerning linking Radio-frequency Identification (RFID) for a supply chain to the Internet (Ashton, 2009). The Internet of Things is an integrated system of intelligent interconnections fused with wireless sensory networks, big data, and cloud computing (Khan *et al.*, 2023). IoT implies the connection of a network of “things” to or through the Internet without direct human intervention (Villa-Henriksen *et al.*, 2020). “Thing” can be any object with sensors or actuators uniquely addressable, interconnected, and accessible online. IoT is a technology paradigm contemplated as a vast network of digitally connected devices and machines (Ashton, 2018). Lee and Lee (2015) presented that IoT technologies are classified into five categories: RFID, wireless sensor networks (WSN), middleware, cloud computing, and IoT applications, essential for deploying successful IoT-based products and services.

Nozari *et al.* (2021) presented the four-layer architecture of IoT for the industrial framework. The first layer indicates information generation with sensors and identification devices; the second represents information transmission by network construction; the third signifies information processing with management methods; the fourth indicates information application using the integrated application. Villa-Henriksen *et al.* (2020), by literature view, noted that there is a general trend to divide the layers of the IoT architecture into three: device, network, and application to cover the range of technologies, protocols, standards, etc. employed. The device layer consists of the physical objects (things) that are capable of automatic identification, sensing or actuation, and connection to the Internet. The network layer communicates the data to a gateway (or proxy server) and then to the Internet (cloud) with communication protocols. While the application layer stores and can be accessed by the end-user for processing and analyzing information.

In the implementation processes of the device layer, there are two processes of data (or information). One is the sending data process, that is, a sensor measures a physical parameter, e.g., air temperature, that is transformed into an equivalent analog signal, i.e., electric voltage or current, which is converted by the interfacing circuit, i.e., Analogue-to-Digital Converter (ADC), into a corresponding digital format. Next, the microcontroller, e.g., microprocessors or single-board computers, collects digital data from one or more sensors through ADC and sends them to the transceiver, i.e., a wireless communication module, which communicates the data to a gateway. The other is the receiving process. When the transceiver receives a signal, the signal is communicated to the microcontroller, where it is converted to an analog signal by a Digital-to-Analogue Converter (DAC) or a digital signal by a Digital-to-Digital Converter, i.e., the interfacing circuit, and finally interpreted by the actuator and acts according to the received signal.

In the implementation processes of the network layer, the network layer communicates the data first to an intermediary platform, next to the Internet (cloud), and finally to the used actuators. When the data are transferred to the intermediary platform, it uses wireless communication technologies such as RFID, WSN, or Near-Field Communication (NFC). The intermediary platform is normally an internet gateway located in the neighborhood of the connected devices, sometimes including a proxy server, where the data are collected and occasionally processed to send the information to the end user through the Internet using standard, e.g., MQTT or protocol, e.g., HTML or XMPP.

In the implementation processes of the application layer, several important services are included, i.e., data storage, data analytics, data access through an appropriate Application Programming Interface (API), and a user interface software application. The middleware platform is also included to handle the heterogeneous cloud data for interoperability. Data storage can be cloud-based, i.e., on multiple or more locally based servers, where data are stored in different databases, depending on the application and design. Data analytics can be achieved by cloud computing, where computer resources are managed remotely to analyze data, often Big Data, or by distributed computing, e.g., edge and fog computing. The IoT middleware platforms are especially suitable for solving different challenges in the application of IoT, e.g., interoperability. IoT middleware platforms try to simplify complex communication through the cloud due to the heterogeneity of devices, communications, and networks by using enablers, e.g., standardized APIs and protocols.

## Internet of Things Application

### *Internet of Things application in supply chain*

IoT is one of the key components of the IT infrastructure for developing smart SC, with a high potential for creating sustainability in systems (Nozari *et al.*, 2021). Traditional SC management systems usually have several problems, such as overstocking, delivery delays, and stock outages. These problems can be attributed to factors such as complexity and uncertainty in SCs for a long time. IoT can help companies to manage these uncertainties and improve SC efficiency. Furthermore, the application of IoT devices can reduce data acquisition costs. Suguna and Kumar (2019) proposed a circulation using IoT solution for SC, including the following issues: 1) understanding inventory levels and warehouse stock, 2) studying product performance and predicting its failure, 3) creating fleet efficiencies for optimization, 4) life cycle visibility of a product, 5) gaining user’s insights. Therefore, companies will invest resources in the IoT to build visibility of the materials stream, decrease materials waste, and lower circulation costs.

Furthermore, Immense network information on warehouse, production, distribution, and retailing is generated by sensors, RFID

tags, meters, actuators, GPS, and so on. It can improve product delivery and tracking capabilities, facilitate transportation decisions, control the temperature and humidity of perishable materials and products, reduce waste, and improve pollution. Therefore, IoT can become the core business form to achieve environmental sustainability and benefit companies.

### ***Internet of Things application in the arable farming***

Arable farming, i.e., farming in an uncontrolled environment, has particular challenges due to the following reasons: much large farm sizes, the spatial data as a central role, great use of mobile sensors and other devices on vehicles, larger amounts of heterogeneous spatial data generated at different rates and from very disparate sources, highly varying and uncertain environmental conditions, more diverse types of field tasks per growing season (Villa-Henriksen *et al.*, 2020). IoT has been gaining advancement in the farming industry as it can fulfill the urgent necessity for interoperability across brands, scalability, and traceability. IoT is still evolving and has the potential to adapt to a great diversity of applications. Villa-Henriksen *et al.* (2020) categorized six applications of IoT in arable farming: monitoring, documentation and traceability, forecasting, controlling, farm management information system (FMIS), vehicle navigation, optimization, and logistics.

### **The Challenges of the Internet of Things**

#### ***The challenges of IoT-based supply chain***

Khan *et al.* (2023) noted that the IoT-based SC faces numerous financial and environmental challenges, such as the higher cost of smart gadgets, especially RFID, and controlling software systems. Misra *et al.* (2022) noted that integrating IoT and business processes is still at a very early stage of development in the food supply chain and food industry. For example, granular data alignment exists when creating an end-to-end digital thread from farm to consumer because of the cross-functional entities in the food supply chain, resulting in the difficulty of data sharing. Usually, raw materials are from developing countries and are processed by developed countries. Collecting all the data in the acquiring process will be challenging.

#### ***The Challenges of the Implementation of IoT in Arable Farming and Food Supply Chain***

Villa-Henriksen *et al.* (2020) identified that interoperability is a major hurdle in the application of IoT. They further presented four related dimensions: technical, syntactical, semantic, and organizational. Technical interoperability refers to communication protocols; syntactical and semantic interoperability is data heterogeneity; organizational one indicates scalability. They grouped the challenges of IoT applications in arable farming into four types: general, device, network, and application layers. The most concerned topics are power consumption and latency/throughput/rate. The former is in the device layer, and the latter is in the network layer. Other concerns are three topics in the general area: revenue/affordability, data heterogeneity, and scalability/flexibility; three topics in the network layer: wireless link quality, communication range, and communication protocols; one topic in the application layer: data analysis.

Jin *et al.* (2020) noted that the biggest challenges with the data generated along the food supply chain are data fairness (i.e., Findability, Accessibility, Interoperability, Reusability, FAIR), data quality, and lack of standardization. Moreover, they especially noted that one of the challenges that have caused the limited uptake of IoT technology in food safety is that the data produced by IoT devices can be difficult to interpret, communicate, and share because of a lack of standardized communication protocols. They further noted that applying FAIR guiding principles in IoT devices can help solve the lack of standardized communication protocols. In addition, they also noted that several issues are related to IoT security in food safety, such as inadequate hardware and software security. This problem can result in a vulnerable point for the security of the entire IoT system and the rest of the Internet. Therefore, the security risks analysis on IoT should be considered (Nozari *et al.*, 2021).

### **Big Data, Cloud Computing, and the Internet of Things**

Addo-Tenkorang and Helo (2016) defined “big data” as “a fast-growing amount of data from various sources that increasingly poses a challenge to industrial organizations and also presents them with a complex range of value-use, storage and analysis issues”. International Data Corporation (IDC) outlined five attributes of big data: big data development sources (Variety – V1), big data acquisition (Velocity – V2), big data storage (Volume – V3), big data analysis (Veracity – V4), and big data value adding to industry (Value-adding – V5). Addo-Tenkorang and Helo also outlined some of the most widely used “big data” operational tools: cloud computing, master database management system, apache Hadoop, map-reduce, apache Cassandra, Pentaho, apache mahout.

Min *et al.* (2014) elaborated on the relationship between big data and cloud computing: big data depends on cloud computing as the foundation for smooth analytical operation. Namely, cloud computing analytics provides solutions for storing and processing big data. Furthermore, cloud computing virtual storage technology can effectively analyze and manage big data through parallel computing capacity to improve the efficiency of big data acquisition and processing. Additionally, Min *et al.* noted that big data and IoT are interdependent and should be jointly developed. That is, the widespread deployment of IoT drives high data growth, including semi-structured and unstructured. Big data of IoT is useful only when it is analyzed and processed for value-adding.

#### ***The applications of big data/Internet of Things***

The applications of big data/IoT in the agriculture and food industry have been discussed by Misra *et al.* (2022). Misra *et al.* noted that IoT-based virtualization of the food supply chain is critical in minimizing risks and dramatically reducing inefficiencies,

costs, emissions, and social impacts. Moreover, IoT and AI enable customization-oriented production for the food industry.

### ***The challenges of big data/Internet of Things***

Addo-Tenkorang and Helo (2016) suggested that because data and information in general and especially industrial operations or supply-chain management data are confidential and sensitive, thus, the data security aspects of big data/IoT could be investigated for authenticity. In addition, handling big data issues are challenging and time-consuming, requiring a large computational infrastructure to ensure successful data processing and analysis in a reasonable time. At the same time, cloud computing can solve this problem. However, related research on big data in food safety with cloud computing still is in the infancy stage (Jin *et al.*, 2020).

### **Blockchain**

Blockchain technology has been a success in the cryptocurrency world since its launch in 2008. Blockchain is known for its digital decentralized ledger system that does not require a trusted transaction intermediary (Misra *et al.*, 2022). Blockchain technology is essentially a database of records stored as 'blocks', shared among all group members, resistant to data modification. It can be accessed at any time in the future. Therefore, Rana and Sharma (2021) noted that blockchain technology provides multiple features, including a decentralized ledger, smart contract, consensus, provenance, immutable and transparent to ensure trust and transparency in a collaborative environment, for example, the supply chain ecosystem. A distributed ledger technology can enable different entities to communicate in a peer-to-peer network without a middle entity. Consensus is the agreement of all the stakeholders on the execution of a transaction. The most important feature is its immutability, which means no one can modify the transaction in the distributed ledger. Therefore, a provenance feature can provide to trace back all the history of any transaction because all the transactions are recorded in the distributed ledger so that these are transparent to all the connected nodes of a network, that is, all the connected stakeholders. The smart contract is a computer program that contains the logic of a contract between two or more entities and can be executed when certain conditions are met.

Rana *et al.* (2021) proposed a model containing digital documents, the Ethereum blockchain, an interplanetary file system, and system users to substitute the conventional centralized approach. Many documents, such as purchase orders, delivery advice, payment notification, etc., are uploaded by different stakeholders like manufacturers, distributors, retailers, etc., during the production process of goods to their delivery to consumers. Because these stakeholders will access these documents during the process, the security and integrity of these documents are of prime concern. Any tampered-with or manipulated documents can lead to distrust. Therefore, decentralized access control is needed. Ethereum is an open-source public blockchain platform with a smart contract to develop decentralized applications. It uses a ledger to store the access transactions of documents which cannot be modified due to the immutability feature. The interplanetary file system is a distributed system to store and access these digital documents. Once a file is stored on an interplanetary file system, a unique cryptographic hash is returned, which is used to address or identify that file. Digital documents will be stored in encrypted form on the interplanetary file system in the proposed model. System users are provided with a pair of keys to access the digital documents related to them.

Blockchain technology can be extended to a food supply chain where information such as production data of food, origin, storage and shipping temperature, expiry date, etc., can be digitally stored in a database, enabling rapid identification of an outbreak or authenticity of food (Misra *et al.*, 2022). Blockchain can provide a solution to keep records and track food items to implement food safety and integrity measures, bringing transparency and accountability to the supply chain. The prominent cases are Walmart and IBM (Misra *et al.*, 2022). The related application of blockchain in food safety traceability is elaborated by Misra *et al.* (2022).

Misra *et al.* also noted that when blockchain technology is adopted widely, standardizing the protocols used in the blockchain is urgent because of smart contracts suitable for data sharing, blockchain with strong algorithms suitable for data privacy, and its integration with AI suitable for data immutability.

### **Digital Supply Chain Twin**

#### ***Digital twin***

Kamble *et al.* (2022) noted that a digital twin integrates virtual and physical systems using disruptive technologies. A digital twin is a virtual model and comprehensive description of the system used to understand the performance parameters, improve processes, and effectively enhance value-added activities (Park *et al.*, 2019). A digital twin is a digital counterpart of the physical systems based on a simulation that deals with design systems and optimizes them for improving efficiency (Guo *et al.*, 2019). The digital twin can simulate the manufacturing environment based on the collected information and helps the owner decide between the available actions for increased efficiency, better accuracy, and economies of scale (Negri *et al.*, 2017). A digital twin can control production processes in response to the changing market needs with high accuracy and agility (Kamble *et al.*, 2022). Park *et al.* (2020) noted that digital twin frameworks have considered one or more manufacturing facilities to develop independent customized applications. However, they can still not develop a digital twin as a core technological element of the entire system. In brief, the relevance of digital twins in the manufacturing industry lies in the definition of virtual counterparts of physical devices (Negri *et al.*, 2017).

Similarly, Miller *et al.* (2020) noted that a digital twin is a digital representation of a physical thing's data, state, relationships, and behavior. There is a need to develop digital supply chain twins in recent studies. Gerlach *et al.* (2021) suggested that a digital supply chain twin is a new application of a classic digital twin and represents a new, innovative technology concept. Therefore, the definition of digital supply chain twin should be clearly distinguished from that of digital twin.

### **Digital supply chain twin**

A digital supply chain twin is used for advanced supply chain modeling based on prescriptive analytics that works in real-time and can determine the proper corrective action supporting supply chain optimization (Kamble *et al.*, 2022). They further revealed through a systematic literature review that a digital supply chain twin drives manufacturing resources aggregation, integration, and dynamic allocation, creating a valuable link in complex supply chains. Moreover, a digital supply chain twin is a virtual supply chain mirror consisting of hundreds of physical assets and warehouses, logistics, and inventory positions. Gerlach *et al.* (2021) noted no consensus regarding digital supply chain twins in the literature. Defining the digital supply chain twin in the literature depends on its specific purpose. Thus, a conceptual clarification for the digital supply chain twin is proposed by Gerlach *et al.* (2021). A digital logistics twin or digital supply chain twin is a digital dynamic simulation model of a real-world logistics system with the characteristics of a long-term, bidirectional, and timely data link to that system. The digital supply chain twin enables diagnostic, predictive, and prescriptive methods to improve logistics performance throughout the customer order (Gerlach *et al.*, 2021).

Kamble *et al.* (2022) identified seven components of digital supply chain twin architecture by systematic literature review: industrial internet of things (IIoT), modeling and simulation, cyber-physical systems, artificial intelligence and machine learning, blockchain and smart contracting, cloud computing, augmented reality, and virtual reality. Kamble *et al.* (2022) propose a sustainable digital supply chain twin framework, including 1) the physical layer (i.e., IIoT, cloud computing, blockchain, virtual reality), 2) the digital supply chain layer (i.e., digital planning, modeling, and analytics), 3) the analysis layer of digital supply chain twin (i.e., artificial intelligence, machine learning, big data analytics, and simulation models), 4) the application layer of digital supply chain twin (i.e., to observe real-time supply chain behavior, sourcing policy, inventory status, production and delivery schedules, etc. with proactive supply chain optimization), 5) sustainable supply chain objectives (i.e., economic, environment, and social).

There are three scopes of digital supply chain twin in the literature: network level (i.e., a multi-stakeholder value network), site level (a logistics site such as warehouses, production facilities, and others), asset level (a logistics asset, for example, trucks, forklifts, and so on) (Gerlach *et al.*, 2021). Specifically, the asset level is related to the digital twin domain and not the area of digital supply chain twins. The related application cases regarding network and site level are discussed by Gerlach *et al.* (2021).

What are the benefits of digital supply chain twin implementation? Kamble *et al.* (2022) mentioned that the digital supply chain twin provides significant insights into sustainable supply chain performance, and it responds to different inputs to unveil hidden opportunities by offering answers to how and why various supply chain events occur, thus, providing opportunities for supply chain transformation. Gerlach *et al.* (2021) noted that supply chain transparency, increased supply chain performance through a higher reaction speed, improved flexibility and resilience, and improved user's ability to make fact-based decisions are three identified benefits of the network digital supply chain twin. Moreover, transparency and increased site-wide flexibility and resilience are the identified benefits of the site digital supply chain twin.

### **The challenges of digital supply chain twin**

The digital twin shows considerable potential to track and trace the products for better quality and improved productivity. However, several problems must be overcome, including long idle time and energy waste (Wang *et al.*, 2020). The challenges identified for developing an efficient digital supply chain twin are the product's life cycle, cybersecurity, IP protection, and unstructured data sources (Kamble *et al.*, 2022).

## **CONCLUSION**

This review lists the definition of digital supply chain in the extant literature and identifies the relationship with smart supply chain to answer RQ1. Next, the four components are critical in the digital supply chain: the Internet of Things, big data, blockchain, and digital supply chain twin. We elaborate on their basic principle, the application cases, and possible challenges to answer RQ2. These technologies are evolving continually, and its applications areas are expanding so that the possible challenges are changing accordingly. However, the challenges identified by this review are worth exploring furtherly.

Moreover, the review shows that the most widely used technology is IoT. The technologies combining IoT, cloud computing, and big data analysis are the most common applications from the data flow view. Blockchain is a developing technology. The smart contract is worth furtherly exploring its applications. In contrast, the digital supply chain twin is an integrated technology encompassing simulation. Most of it is used in decision choices of multiple possible strategies. Other technologies, such as robotics, drone, 3D printing, virtual reality, cyber-physical systems, and others, are worth further exploring their applications in the digital supply chain in the Industry 4.0 era.

## **REFERENCES**

Ashton, K. (2018). How the term 'Internet of Things' was invested. In A.D. Rayome (Ed.), *Tech Republic*.



- Rana, A.K., & Sharma, S. (2021). Industry 4.0 manufacturing based on IoT, cloud computing, and big data: Manufacturing purpose scenario. In *Advances in Communication and Computational Technology* (pp. 1109-1119). Singapore: Springer.
- Suguna, S.K., & Kumar, S.N. (2019). Application of cloud computing and internet of things to improve supply chain processes. In *Edge Computing: From Hype to Reality* (pp. 145-170).
- Addo-Tenkorang, R., & Helo, P.T. (2016). Big data applications in operations/supply-chain management: A literature review. *Computers & Industrial Engineering*, *101*, 528-543.
- Ashton, K. (2009). That 'internet of things' thing. *RFID journal*. <http://www.rfidjournal.com/articles/view?4986>.
- Buyukozkan, G., & Gocer, F. (2018). Digital supply chain: literature review and a proposed framework for future research. *Computers in Industry*, *97*, 157-177.
- Gerlach, B., Zarnitz, S., Nitsche, B., & Straube, F. (2021). Digital supply chain twins: Conceptual clarification, use cases and benefits. *Logistics*, *5*, 86. <https://doi.org/10.3390/logistics5040086>.
- Guo, J., Zhao, N., Sun, L., & Zhang, S. (2019). Modular based flexible digital twin for factory design. *Journal of Ambient Intelligence Humanized Computing*, *10*(3), 1189-1200.
- Hofmann, E., & Rüscher, M. (2017). Industry 4.0 and the current status as well as future prospects on logistics. *Computers in Industry*, *89*, 23-34.
- Huang, C.C., Ye, C.S., Wang, X.X., & Shi, Z.M. (2018). Research on the construction of intelligent supply chain system. *Value Engineering*, *37*(23), 21-23.
- Ivanov, D., Dolgui, A., & Sokolov, B. (2019). The impact of digital technology and Industry 4.0 on the ripple effect and supply chain risk analytics. *International Journal of Production Research*, *57*(3), 829-846.
- Jin, C., Bouzembrak, Y., Zhou, J., Liang, Q., van den Bulk, L.M., Gavai, A., Liu, N., van den Heuvel, L.J., Hoenderdaal, W., & Marvin, H.J.P. (2020). Big data in food safety: A review. *Current Opinion in Food Science*, *36*, 24-32.
- Kamble, S.S., Gunasekaran, A., Parekh, H., Mani, V., Belhadji, A., & Sharma, R. (2022). Digital twin for sustainable manufacturing supply chains: Current trends, future perspectives, and implementation framework. *Technological Forecasting & Social Change*, *176*, 121448. <https://doi.org/10.1016/j.techfore.2021.121448>
- Khan, K., & Keramati, A. (2023). A framework for smart supply chain risk assessment: An empirical study. *International Journal of Information Systems and System Chain Management*, *16*(1), 1-17.
- Khan, Y., Suud, M.B.M., Alam, M.M., Ahmad, S.F., Ahmad (Ayassrah), A.Y.A.B., & Khan, N. (2023). Application of Internet of Things (IoT) in sustainable supply chain management. *Sustainability*, *15*, 694. <https://doi.org/10.3390/su15010694>
- Lee, I., & Lee, K. (2015). The internet of things (IoT): Applications, investments, and challenges for enterprises. *Business Horizons*, *58*(4), 431-440.
- Lee, J., Bagheri, B., & Kao, H.-A. (2015). A cyber-physical systems architecture for industry. *Manufacturing Letters*, *4*, 18-23.
- Liu, C., Ji, H., & Wei, J. (2022). Smart supply chain risk assessment in intelligent manufacturing. *Journal of Computer Information Systems*, *62*(3), 609-621.
- Min, C., Shiwen, M., & Yunhao, L. (2014). Big data: A survey. *Mobile Network Applications*, *19*, 171-209.
- Misra, N.N., Dixit, Y., Al-Mallahi, A., Bhullar, M.S., Upadhyay, R., & Martynenko, A. (2022). IoT, big data and artificial intelligence in agriculture and food industry. *IEEE Internet of Things Journal*. <https://doi.org/10.1109/JIOT2020.2998584>
- Negri, E., Fumagalli, L., & Macchi, M. (2017). A review of the roles of digital twin in CPS-based production systems. *Procedia Manufacturing*, *11*, 939-948.
- Nozari, H., Fallah, M., Kazemipoor, H., & Najafi, S.E. (2021). Big data analysis of IoT-based supply chain management considering FMCG industries. *Business Informatics*, *15*(1), 78-96.
- Oztemel, E., & Gursev, S. (2020). Literature review of Industry 4.0 and related technologies. *Journal of Intelligent Manufacturing*. <https://doi.org/10.1007/s10845-018-1433-8>
- Park, K.T., Lee, J., Kim, H.-J., & Noh, S.D. (2020). Digital twin-based cyber physical production system architectural framework for personalized production. *International Journal of Advanced Manufacturing Technology*, *106*(5-6), 1787-1810.
- Park, K.T., Nam, Y.W., Lee, H.S., Im, S.J., Noh, S.D., Son, J.Y., & Kim, H. (2019). Design and implementation of a digital twin application for a connected micro smart factory. *International Journal of Computer Integrated Manufacturing*, *32*(6), 596-614.
- Rana, A.K., Kim, H.-C., Pani, S.K., Rana, S.K., Joo, M.-I., Rana, A.K., & Aich, S. (2021). Blockchain-based model to improve the performance of the next-generation digital supply chain. *Sustainability*, *13*, 10008. <https://doi.org/10.3390/su131810008>
- Villa-Henriksen, A., Edwards, G.T.C., Pesonen, L.A., Green, O., & Sorensen, C.A.G. (2020). Internet of Things in arable farming: Implementation, applications, challenges and potential. *Biosystems Engineering*, *191*, 60-84.
- Wang, W., Zhang, Y., & Zhong, R.Y. (2020). A proactive material handling method for CPS enabled shop-floor. *Robotics and Computer-Integrated Manufacturing*, *61*, 101849. <https://doi.org/10.1016/j.rcim.2019.101849>
- Wu, L., Yue, X., Jin, A., & Yen, D.C. (2016). Smart supply chain management: A review and implications for future research. *The International Journal of Logistics Management*, *27*(2). <http://dx.doi.org/10.1108/IJLM-02-2014-0035>
- Xu, X.X., & Han, Y.L. (2018). Research on smart supply chain construction under the background of 'Internet'. *Smart Factory*, *1*(4), 36-38.
- Zhang, G., Yang, Y., & Yang, G. (2023). Smart supply chain management in Industry 4.0: The review, research agenda and strategies in North America. *Annals of Operations Research*, *322*, 1075-1117.
- Zhao, Z.Z., & Wang, F. (2014). Top level design on smart supply chain cost control house system: An example of oil and gas mining area. *China Soft Science*, *1*(8), 184-192.

- Bhargava, B., Ranchal, R., & Othmane, L.B. (2013). Secure information sharing in digital supply chains. *3rd IEEE International Advance Computing Conference (IACC)*. <https://doi.org/10.1109/IAdCC.2013.6514473>.
- Kinnett, J. (2015). Creating a digital supply chain: Monsanto's journey. *SlideShare*, 1-16. Retrieved from <https://www.slideshare.net/BCTIM/creating-a-digital-supply-chain-monsantos-journey> (Accessed 17 August 2023).
- Miller, P. (2020). *Grasp the Challenge of Implementing Digital Twins at Scale: Digital Twins Show Great Promise, but Early Adopters Struggle with Technical and Organizational Barriers as They Scale*. Retrieved from <https://www.forrester.com/report/Grasp-The-Challenge-Of-Implementing-Digital-Twins-At-Scale/RES158396> (accessed on 17 August 2023).

## **Towards Delivering AI & Smarter, Self-Learning, Autonomous, Humanoid Robots**

John R. Hamilton <sup>1,\*</sup>  
Stephen J. Maxwell <sup>2</sup>  
Ronald P. Lynch <sup>3</sup>

---

\*Corresponding author

<sup>1</sup> Adj. Chair Professor, James Cook University, Cairns, Australia, John.Hamilton@jcu.edu.au

<sup>2</sup> Researcher, Doctor, James Cook University, Cairns, Australia, Stephen.Maxwell@my.jcu.edu.au

<sup>3</sup> Researcher, Doctor, James Cook University, Cairns, Australia, Paul.Lynch@jcu.edu.au

### **ABSTRACT**

The shift in artificial intelligence (AI) from mildly-intelligent data manipulation to complex AI that fuses global data, plus sensory capture, along with interpretation, interpersonal and environmental assessment and virtual realities systems, and that then network-collaborates, self-learns and continually coalesces with internet of everything (IoE) manipulative devices to deliver more advanced, and typically improved solutions, is now a reality. AI is progressively developing and is currently around stage four of ten projected generational levels, and human centric robots are now in existence. These humanoid robots are continually advancing, incorporating further innovative developments, and moving towards super-human intelligence stages.

*Keywords:* neural network, AI generation level, artificial intelligence, innovation, creative technology, super intelligence, robotic engineering, virtual reality, augmented reality

### **INTRODUCTION**

#### **Industrial Robots**

In the past, robotics has encompassed a broad interdisciplinary sector encompassing: engineering, electronics, data connectivities, and computer science. Early robots were designed to assist humans in repetitive, and often monotonous, workplace activities.

#### **Status of Robotics Today**

Today, countries including the United States, Japan, China, Singapore, South Korea and Taiwan are heavily involved in robotics R&D. Robotics remains a complex engineering domain covering creation, design, building, use, and application of robotic and human technologies into individual automatically or autonomously operated machines capable of independently performing sequenced-series of specifically-actioned combination activities or tasks whilst incorporating open-ended double-loop improvements to the learning cycle. AI also engages IoE manipulative devices and these deliver more advanced, and typically improved solutions for consumers and the marketplace.

PcW project by 2030 intelligent robots are likely to replace up to 30% of human vocations – including ongoing personal learning/education at home, menial tasks (like cooking, washing items, and cleaning), exploring, solving, and rectifying equipment failures, providing entertainment, sourcing latest desired items, along with interacting, sharing, and advancing-the-potential of humans.

However, robots can operate beyond the personal domain. Some can operate in complex environments. Some help understand change - such as: change in climate, adaptive change in vegetation and/or species, change in health, change in sentiment, change in capabilities. Some can automate devices, find energy sources, solve medical and/or legal issues, improve creativity and innovation. Some can learn, become uniquely versatile and perform tasks beyond human capabilities. Some can manufacture without humans. Some can diagnose treat and rehabilitate humans. Some can move objects or drive machinery/automobiles.

Robots can also: handle repetitive tasks perfectly with ongoing objective recall. They can consistently and optimally execute acts of strength, deliver requirements at rapid speeds on a 24/7/365 basis. They can sense without distraction. They can learn and recalibrate towards better actions. Thus robots, combined with appropriate AI and engineering, are transforming the environment in which human's live, and they are navigating humans towards tomorrow's rapidly changing, efficient, interconnected, and specifically-consumerized future.

AI adds new levels of complexity. It encompasses a vast array of digitally-related fields including ML, connected algorithms virtual/augmented/extended realities, neural networks, technological singularity (a specific time point where AI surpasses the human-level of general intelligence and reaches the point of super intelligence), the IoE big data, global learning, and sensory (6<sup>th</sup> sense) perception.

Thus, robotics and AI likely bring new dimensions of human competitiveness and interactive dynamics - where humans no longer keep-up with engineering, autonomous systems, and digital and data intelligence advances occurring - unless they can possibly cyborg themselves complete with their own super-intelligent AI. (Mclay, 2018)

### LITERATURE REVIEW

Robotics has progressed much in-line with the five generational levels of development in AI as discussed and contextualized by Hamilton and Maxwell (2023), and represented as Figure 1's five generational levels of AI. First, simple reactive AI systems encompass rules knowledge-based pre-programmed non-learning tasks. Second, limited AI systems are context-based and retention systems with training built around data. Third, augmented machine learning (ML) AI systems are expert systems that manage domain excellence from application, to analysis, to synthesis, to evaluation. Fourth, deep-learning (DL) 'brain' AI networks are reasoning AI systems that can assess multi-data suites into solutions that simulate human thought. Fifth, superintelligent self-aware AI neural networks display human-like conscientiousness, intelligence, and retrospectivity that reflects cognitive processes across allocated domains. These five generational levels of AI closely align with the first five stages of AI development (Anon1, 2023, Anon2, 2023). A sixth generational level is also conceptualized for the future (Anon 2023, Anon2, 2023), and this is discussed later in this paper, along with four additional proposed more-complex, stagewise-developing generational levels of AI.

Figure 1 suggests today aspects of all five AI generation levels exist but the boundaries between each generation level remains fuzzy and subject to change. As robotics has incorporated more AI, and has delivered more capabilities, its purpose has become better-aligned to the requirements of the application into which it operates. Today, the field of robotics is also capable of fourth and fifth AI generation level aspects including self-learning, and in some cases even mimicking the behaviors and senses of humans.

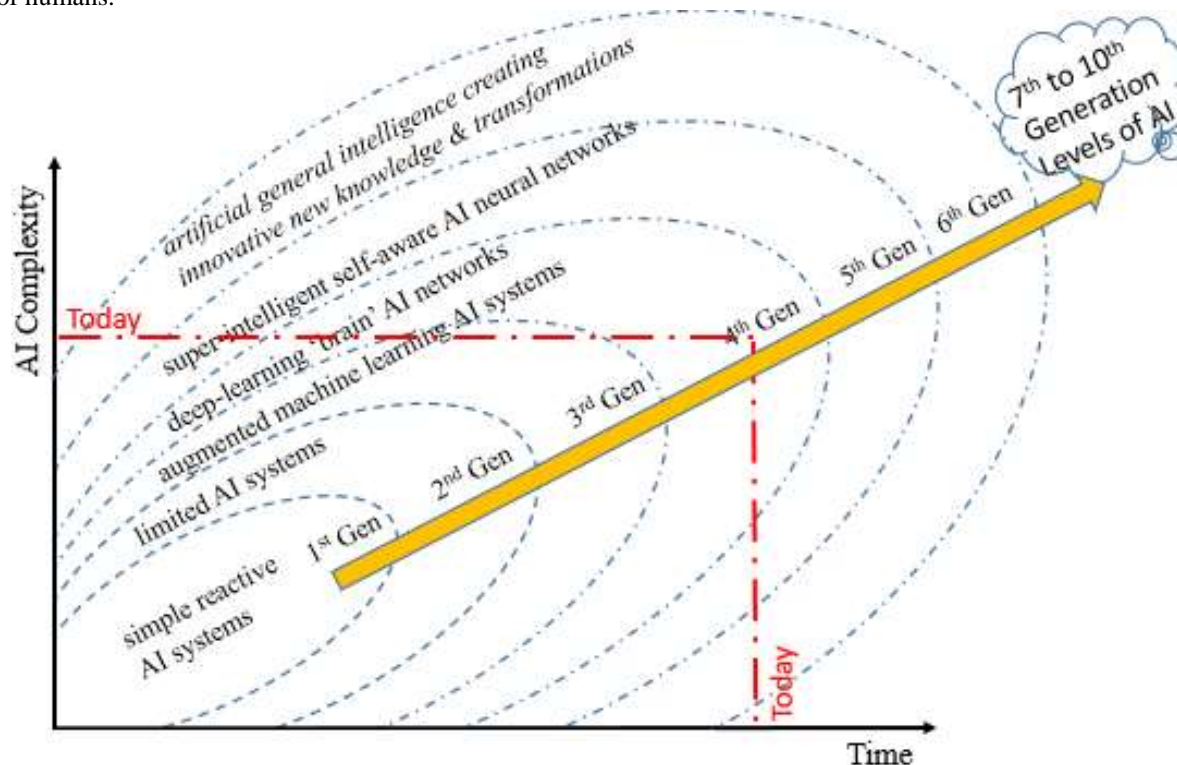

Source: Adapted from Hamilton & Maxwell, (2023).

Figure 1: Specificity/complexity of data deployed over-time via different generations of AI

Iglesias et al. (2024) show low-rigidity robots in industry can enhance the machining of metals by iteratively training and reducing the deviations caused by cutting tool path tolerance. This self-improving algorithm for aluminium milling modifies and improves programmed path coordinates to within a 300um flatness tolerance, and reduces deviation error by 17%. It also allows human's to attain higher levels of capabilities, promote their personal safety and improve their well-being. Thus, some robotics actions can also help improve human capabilities

Lyu. & Brennan, (2024) test self-managed industrial automation multi-agent architecture systems at the real-time control level of the architecture. This autonomic monitoring, analysis, execution and knowledge management computing system allows

response adaptation to disturbances, and so saves both costs and time compared to manual reconfigurations. They find their proposed multi-agent algorithm architecture can respond to frequent changes - thereby enabling this system to autonomously discover both alternative solutions and to flexibly-coordinate reconfigurable agent-embedded modules. Thus certain multi-agent algorithms can capture, assess, and autonomously respond/adapt to recognized changes in their architectural data capture domains, and such algorithms can be programmed into a robot's real-time reconfiguration capabilities suite.

Wen et al. (2023) design a new multi-layer integrated, encoding method for integrated planning and scheduling in manufacturing. Encoding includes (1) feature layer, (2) operation layer, (3) machine layer and (4) scheduling layer - allowing a flexible, deeper exploratory solution investigation. Results show the new algorithm finds better near real-time optimal integrated planning and scheduling solutions. Thus, algorithms can be built as fit-for-purpose, real-time, optimal solution providers, and these too can be built into a robot's real-time learning capabilities suite.

Thus, in industry, robots can be programmed to detect, operate, learn, intelligently-manage, and reconfigure: machinery, operational systems, connectivities, and/or product deliverables. Today robots execute many tasks at different AI generation levels including: automate business activities, manage databases, secure important data, work across hazardous environments, monitor ledgers/forms, select and/or prepare pharmacy prescriptions, sort/deliver on-line orders, work as specialist surgeons/medical-assistants, create music monitor dangerous situations/activities, quality-control food, or work as human task assistants. Across all robotic domains their logic and capabilities systems continue to become smarter and capable of more complex solutions, with some robots now mirroring many human behaviors. These humanoid behaviors are sometimes framed around generative AI, deep learning and human centricity assessments.

### Generative AI Emerging 2023 Technologies

Gartner (2023) list its latest August 2023 emerging hype cycle technologies diagrammatically as Figure 2. These emerging technologies are helping to trigger and support latest AI developments. Although different in focus these emerging technologies are developing at the same time and they group across sustainable differentiation and actions within productivity systems. These systems also apply to robotic capabilities and robotic intelligence. Those shown as light blue development positional expectations dots are to reach their productive plateau within 2 to 5 years, and those shown as black dots in 5-10 years, whilst those shown as orange triangles are to mature and productivity plateau in over 10 years.

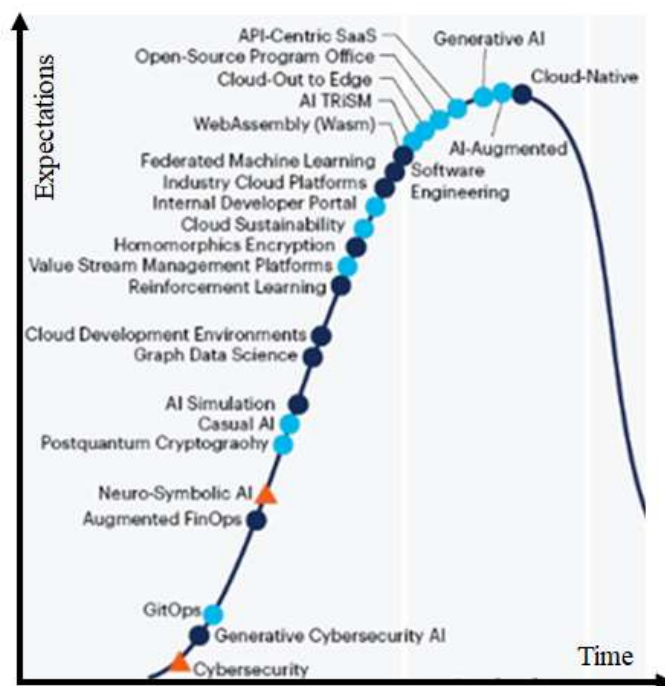

Source: <https://www.gartner.com/en/articles/what-s-new-in-the-2023-gartner-hype-cycle-for-emerging-technologies>

Figure 2: Gartner Hype Cycle for 2023 Emerging Technologies Hype Cycle Stages 1 and 2.

(productivity plateau reached in: 2-5 yrs (light blue circles), 5-10 yrs (black circles), 10 yrs plus (orange triangles))

Currently fourth generation 'generative AI' is a key new and evolving approach (Davenport and Mittal, 2022) that can acquire and remix content strategies designs and methodologies extracted from big data: to robotically automate workforce operations and actions, to neuro-symbolic AI (ML and symbolic systems creating more robust/reliable AI Models), and to reinforcement learning system networks (learning via positive/negative feedback). Generative AI delivers algorithms and models that tap vast amounts of data and then create new output solutions including: text, images, videos. Code data and or 3D/4D renderings. These models generate new content by comparative referencing against their existing database knowledge and then making new predictions. Thus generative AI presents competitive differentiation opportunities, whilst several other related AI



techniques including: AI environment simulations, causal AI predictive relational networks, privacy and security, federated machine learning (without using explicit data sharing samples), graphical data science with structural and behavioral predictive/prescriptive modelling, offer digital consumer experiences along with better business and competitiveness decisions (Gartner, 2023).

Such generative AI solutions also require developer experience - bringing technologies including augmented AI engineering and NLP software advance engineered applications, software as a service application programming event interface connectivities, GitOps controlled cloud application systems, in-house cloud-native software innovative developments, and open-source software plus global data strategic efficiencies models. Hence, developer experience adds themed technologies to capture av workforce capable of delivering optimal development tools using value stream management platforms bringing end-to-end connectivities across technologies, existing tools/devices, all diverse data competencies sources, plus operational processes, performance optimization, costs solutions and overall values deliverance capabilities (Gartner, 2023).

A second emerging technologies component of generative AI is the use of pervasive clouds. These add augmented governance-related FinOps across ongoing DevOps, ready-to-use remote, cloud development/assistance environments, cloud sustainability benefits into economic/environmental/social systems, cloud-native leveraging of capabilities to deliver marketplace serving, cloud-edge hyper-scale capabilities services and secure high-performance website and page assembly. Pervasive clouds are complex and add vertically-integrated (SaaS, PaaS, IaaS), reimaged, firm-relevant, global-data-assisted solutions which can then enhance and move AI competencies and capabilities into innovative coalesced, more agile, automated scaleable, responsive, disruptive AI business platforms (Gartner, 2023).

Cho and Nam (2023) consider robotic AI. They use Beau (a public service robot), and demonstrate its generative AI dairies can help communicate acquired social experiences and perspectives into human-robot interactions. Petrescu and Krishen (2023) consider robotic hybrid intelligence (human-AI collaboration) essential in development of generative AI and in advancing consumer personalized experiences. Hybrid intelligence as a generative AI development assists in efficiently optimizing benefits/challenges across marketplace analytics and strategy.

Thus generative AI advances remain continual over the next 2 to 5 years, and generally involves increasingly complex uses of globally-integrated digital data. These advances also coalesce with many other Figure 2 emerging technologies to bring new explored, innovated, developed, and implemented fourth generation level solutions into reality, and almost all these solutions offer some complex new addition into the development of smarter robotics.

### **Deep-Learning**

Deep learning (DL) is another fourth generation level AI approach that continues to evolve. Soori,(2023), Aslani & Jacob (2023) and others believe AI, ML and DL collectively are making robots more intelligent, efficient, and adaptable to task complexities. AI, ML and DL also have advanced applications in intelligent transport and intelligent GPS domains, in cosmetic and reconstructive facial plastic surgery, in clinical radiology, and in enhanced DL operational performance and efficiencies.

Today, cobots adaptably-work alongside humans and can deliver innovative performance solutions to difficult problems such as convenient autonomous navigation, object recognition and manipulation, natural language processing, and predictive maintenance. This likely improves efficiencies, convenience, and marketplace satisfaction, and at lower costs. Further, in market-leading industrial areas with cobots deployed, and across key optimizable applications, their embedded platforms and learning algorithms can innovatively investigate and modify complex productivity and/or performances previously thought to be impossible. This innovative DL AI continues to progress rapidly but incrementally at the higher generational levels.

AI can also follow narrow, or broad, DL creativity pathways. DL interactivity typically draws on OpenAI, Google, Amazon, Facebook, and other data storages, and enlists data to 'do things' and may help in moves towards an alternate future (Hua & Raley, 2023). For example, in music multiple AI toolkits can coalesce and assist some musicians in becoming more creative (Ji, 2023). Akkem et al. (2023) show farming can smarten using AI, and Strolin et al. (2023) use smart AI in organ-at-risk delineations. Thus smart and creative DL AI has diverse and specific narrow applications or broad general applications, and this capability is dependent upon the data-stores and the data-mining applied. DL is likely a necessary ongoing smart robotic capability

### **Human Centricity**

Human centricity extends into fifth generation level AI. Human centricity perceives humans as central to relevant operations. Human centricity engages AI to prioritize human psychological needs, wants, desires, delights and fun across all contexts of self-actualization and personal growth. Extended reality tools like digital twinning help realize human centricity within smart firm operational systems by coupling humans characteristics into net value deliverance (qualities, performance and economic worth) actions across the overall system design.

Gartner (2023) expands human centricity by adding overall cyber mesh-architecture security, and content/strategies/designs/methods, as generative AI cyber-security - through repositories and original data learning, homomorphic encryption to interface firms without compromising privacy and with post-quantum cryptography can likely secure systems against

quantum-computing attacks. This helps facilitate smarter firm operations, and likely delivers further ongoing firm competitiveness (Hamilton et al. 2020, Wang et al. 2024). Digital twinning adds to operational enhancements, but it also drives further creative developments at the human end of the twin. Thus by joint exposure to situational decisions both the digital twin and the physical human typically conjointly learn and advance understanding within themselves (Wang et al. 2024). Human centricity can also incorporate security and privacy AI programs and further support shared decision-making risks across governance, trustworthiness, fairness, reliability, robustness, efficacy and AI data protection, whilst also blocking adversarial attacks (Gartner, 2023). Thus robots incorporating human centricity AI capabilities can learn and advance their understanding regarding a typical situation.

## ANALYSIS and DISCUSSION

### Humanoid Robotics and AI

Humanoid robots are fifth generation level devices with high levels of neural-networking AI approaches that coalesce and behave as human-like, evolving, technical and innovative competitive competencies and capabilities supported by deep-learning thoughtful processes and skilled manipulative abilities. Humanoid robots don't need to sleep (provided they are connected to an energy source) and can deliver 24/7/365 reasoned, skilled, and consistent actions that appropriately deliver optimal solutions in-time, on-time and every-time. In remote humanoid robot teleoperations, integration of cognitive skills and domain expertise of humans integrates with the physical capabilities of humanoid robots, but to date, in unstructured environments with limited communicative capacities the general architecture still requires refinement (Darvish et al. 2023). Humanoid robots are still developing, and cannot yet behave appropriately in highly-abstract situations and at multiple cross-thought levels.

Aivaliotis et al. (2023) use Microsoft's HoloLens 2 and a robotic operation system with augmented reality software and digital twinning to flexible, mobile, untrained robots. These simplify and accelerate human automotive manufacturing assembly tasks. Their new intelligently-learned robotic motions and failure recovery corrections improve production line speed, flexibility, optimization and system fidelity. Singh et al. (2023) monitor human-robot collaboration behavioral navigation and in a social setting. They show humans prefer robots as assistants - enabled via audio and visual behavioral social aids. They clarify expected resultant behaviors of delivery robots. Semeraro et al. (2023) review research on human-robot collaboration showing ML algorithms can deliver deep learning reinforcement across time-dependent, supervised (or unsupervised) actions in collaborative assembly, object handover, object handling and collaborative manufacturing. They find using sensory (vision) perception modelling of human behavior can reduce human physical workloads, and different robotic architectures combined with ML techniques offer useful collaborative digital twinning solutions. These teleoperations of humanoid robots integrate cognitive skills and domain expertise into intelligent desirable solutions (Darvish et al. 2023). Thus the humanoid robots domain continues to innovate by advancing and incorporating further additional fourth and fifth generation level AI and engineering-related components into increasingly-complex and smarter robotic deliverance solutions.

### Engineering - Strength, Learning, Skill, Speed, Expression, Reality

Around 2010 robotics was generally considered as component-based (Brugali & Scandurra, 2010a; 2010b). By 2023 robotics advanced and internalized to encapsulate digital complex robot operating systems engaging interactive software engineering operating systems (Albonico et al. 2023) and knowledge-based engineering across robotic manufacturing system architectures that today deals iteratively with optimal solutions to consumer demands, and marketplace competitiveness – sometimes using an integration of software approaches such as ontological knowledge and multi-attribute decision-making models. (Zheng et al. 2023). Thus robotic operating systems with their embedded AI systems collect, coalesce, and utilize latest available knowledge, and in real-time, extract relevant best decision solutions to the existing problem or request.

These digital solutions also draw upon physical combinations of robotic features such as: strength, speed, movement, skill, expression, realities, and time. Robotic arm strength exceeds humans. For example Liu et al. (2023) show thermal processing during roll-forming impacts microstructure and mechanical behavior of ultra high-tensile strength steel. A rectangular laser source can homogenize temperature around a bending corner and deliver much lower stress, and less springback, across the sharp bending radius area created by the robotic arm. Thus robots and their AI can work under high strength and high temperature environments to deliver precise, very-controlled physical solutions or alterations.

Li et al. (2023) show robots can self-learn. They create reconfigurable muscle strength bionic training robotics AI that imitates physicians conducting precise patient muscle strength training. This robot can rehabilitate patients across 17 key human body joints including shoulder, elbow, wrist, hand, knee, ankle, wrist, hip, waist. This robot and AI can assist the patient in physical limb rehabilitation, help reduce muscle atrophy, and help increase muscle strength. Thus robots and AI can bring skill, learning, and training into their physical capabilities toolkit.

Lee et al. (2023) track skill level and capacity-to-communicate and impacts on team dynamics, and perceptions of safety and trust. These AI relevant constructs help better design agile, robot-human collaborative performance maneuvers across dynamic high-speed settings. Further, Perez-Villeda et al. (2023), imitate learning skills enlisting supervised learning against analytical expressions to extrapolate capabilities against specific tasks and to then imitate these solutions and so generalize and generate unpredictable motions across range expansion domains. They find robots and AI learning skills (as a performance) positively correlate with trust in collaborative environments, but more research is needed to clarify how safe and trustworthy agile robots



and AI best operates in close proximity to humans. Thus robots and AI can capture, develop, and improve their acquired skills, but this domain is still under ongoing improvement.

Ojstersek et al. (2023) show in simulation environments cobots (collaborative robots) robots and AI can optimize speeds/accelerations and these do affect human and production efficiencies. Further, from the human perspective, cobot optimized production speed/acceleration is critical to optimizing efficient manufacturing systems. Others (Wang et al. 2023) claim in specific manufacturing processes high-complexity, high-efficiency, and precision are other speed-related cobots and AI capabilities deliverables. Thus robots and AI can optimize and perform at speed, precision and efficiency.

Legun et al. (2023) qualitatively consider what Agtech robot and AI task expression aspects of an expert can be replaced by a robot, showing autonomous robots as experts in the technical domain can reduce inequalities in agricultural activities. Others develop 'robot and AI' emotional expressions for robots or consider human-robot social emotional expression interactions and trustworthiness, capabilities to recognize human facial expressions, and recognition plus response to human emotional expressions. Thus 'robot and AI' expression is multi-modal, and complex, to match against human behaviors, but lead examples already closely mimic human expressional deliverance.

Moshayedi et al. (2023) simulate robotic operation systems and control integration of virtual reality (VR) technologies into robotics to facilitate behaviors within realistic environments. They find these robotic situations closely and accurately replicate real-life and relevant real-world dimensions. They believe this simulation approach can explore autonomously-guided vehicle platforms, and locate discernable disparities to actual executions. De Becker et al. (2023) study barriers to integration and adoption of augmented reality (AR) in robotic surgery. In real-time they superimpose a three dimensional model across the surgery stream and its instrument results, and identify potential surgical hazards. They apply robotic AR-guided kidney partial nephrectomy DL algorithm findings to kidney transplants, and detect all nonorganic items. This work now extends to detection and tracking of organ deformation for full clinical implementation. Thus AI reality algorithms can be improved via coding or by VR/real-world comparisons and assessments, and so can deliver new AI capabilities to robots.

### **AI Device Deployment**

AI engages key digital products including big data, VR, AR, mixed realities, and extended realities, along with ML and multi-layer three dimensional and four dimensional electronics. AI also coalesces these and works with smart engineered device components, IoT, printing, and materials transition components. AI is also a key to holograms, telepathy and sensing. AI extends to humanoid robots, and their emotional recognition, and responses. Hence AI today is deployed in almost industry or profession where digital engagement is occurring, and where AI, and smart human-robotics collaborations, can advance, enhance, or optimize actions, and/or operational processes.

### **The Future of Humanoid Robots**

Beyond Figure 1 and Figure 2's emerging technologies, a further five stage-wise suites of AI generational levels is also conceptualized to advance robots and humanoid robots beyond human intelligence capabilities. These five future generational levels of AI development are sequentially listed as:

6. Artificial general intelligence (AGI) – where AI works like humans across task recognition to understand, learn and apply knowledge capable of adaptable and flexible transformations across existing general intelligences.
7. Artificial super-intelligence (ASI) – where robots work beyond human capabilities, are aware of themselves, and can discover, innovate, and solve, previously unsolvable abstract tasks, resulting in virtually everything being reimaged, reworked, and enhanced.
8. Transcendent AI (TAI) – where AI has autonomy, and can self-develop, and use its collective multiple human and robotic amassed-'mind'-intelligences enabled AI to choose and apply new evolutionary pathways.
9. Cosmic AI (CAI) – where intelligence transcends global and human intelligence, and moves to a cosmic (universe) scale capable of communication between planets, and even other planet colonization.
10. God-like AI (GAI) – where AI is so advanced it is omni-present, omni-scientific, and omnipotent, and capable of understanding, transforming and revolutionizing everything (Anon, 2023, Anon2, 2023).

To move robots beyond Figure 1's five current AI capabilities requires each of these increasingly complex five sequential generational levels (from 6<sup>th</sup> Gen to 10<sup>th</sup> Gen) to gain their required developments - those pertinent to their generational level's own necessary network-integrated creative software coded, neural, sensory, emotive and motion technologies (Anon, 2023, Anon2, 2023). This confluence of future innovative capabilities requires vast new technologies, data capture, IoT connectivities, and super-intelligence, along with numerous self-learning, integrated, neural modules collating, assessing, deciding and delivering on chosen AI actioning solutions.

### **CONCLUSION**

Robotics has shifted from repetitive, monotonous, workplace activities involving basic engineering, electronics, data connectivities, and computer science. It continues to move across increasingly complex generational levels of software and engineering developments. Today robots are operating beyond the personal domain, and early humanoid robots are progressing towards early stages of super-human artificial intelligence capabilities. Each generational change requires new software and hardware developments, but the focus of AI has remained around human centricity perceptions and requirements. Leading first world digitally-astute nations and key large corporate entities are focused on improving current generational levels of AI, and

on progressing towards delivering future generation levels of AI. Their purpose in this trajectory remains a desire to be a global marketplace leader, to win business and to achieve a competitiveness advantage.

Today, smart humanoid robotics involves AI solutions deploying correctly-coded and programmed human centricity robotic component solutions that prioritize smart types Figure 1's first five generational levels of current AI capabilities. These humanoid robots engineer as autonomous, innovative, self-learning integrations of latest (and likely best), point-in-time, relevant innovative engineering, knowledge, and big-data algorithm developments. Such solutions are further complexed with the additional humanoid robot requirements coalescing 'mind' neural-network capabilities coding (including optimizing recognition and response distributed software coding, collective abstract self-development knowledge reasoning, real-time change and adaptability, flexible decision expressions). These expand further to include: available multiple realities, sensing, emotional intelligences, and aspects of available autonomous super intelligence capabilities. Hence robotics is an ongoing, and still unfolding, multi-innovative, technical progression.

Prioritizing AI for smart, self-learning, autonomous, humanoid robots likely enlists Gartner's emerging technologies AI, VR, AR, MR, XR, ML and sensory collaborative digital twinning teleoperational solutions of humanoid robots integrating cognitive skills and domain expertise into intelligent desirable solutions that continue to innovate by advancing and incorporating further additional fourth and fifth generation levels of AI, and integrating these with engineering-related components into increasingly-complex and smarter robotic deliverance solutions.

Into the future, robotic engineering advances continuously, and in an ad-hoc, inventive manner, roughly in-line with ongoing, relevant, innovative technologies developments. AI is digitally dependent on deep-learning, and devices-engagement. Further, humanoid robotics is being structured to move beyond human intelligence and sequentially move across sixth to tenth generational levels of ever-increasing AI.

#### ADDENDUM

By the 18 September 2023 Agility Robotics (USA) is mass producing warehouse humanoid robots, Fourier Intelligence (Shanghai) is trialing humanoid robots to assist elderly persons. By the 3<sup>rd</sup> October 2023 Tesla's intelligent Optimus robot was demonstrated in Taiwan working to deliver service experiences across dynamically changing environments. However, although there are other humanoid robots such as "Sophia," "Ameca," and "Apollo" under development, to date humanoid robots cannot cry or bleed. Into the future, can smart self-learning autonomous humanoid robots exceed human intelligence - when their intelligence is really a confluence of extracted human intelligence database selected/programmed fragments of information? So how smart can robots become? For example: can they ever exceed human intelligence to such an extent that they become God like? Can they ever redesign their own capabilities? Can they reimagine and abstractly build solutions that work beyond human intelligence development and that work consistently across a massive galactic scale? Can they move beyond a time and/or atomic dimension? Lastly, if human intelligence/knowledge databases (and energy) are withdrawn, how, where and when can future robotics generations self-propagate, learn, positively-grow their own capabilities, and have purpose?

#### REFERENCES

- Aivaliotis, S., Lotsaris, K., Gkournelos, C., Fourtakas, N., Koukas, S., Kousi, N., & Makris, S. (2023). An augmented reality software suite enabling seamless human robot interaction. *International Journal of Computer Integrated Manufacturing*, 36(1), 3-29.
- Akkem, Y., Biswas, S. K., & Varanasi, A. (2023). Smart farming using artificial intelligence: A review. *Engineering Applications of Artificial Intelligence*, 120, 105899, 1-12.
- Albonico, M., Đorđević, M., Hamer, E., & Malavolta, I. (2023). Software engineering research on the Robot Operating System: A systematic mapping study. *Journal of Systems and Software*, 197, 111574.
- Anon1 (2023). 10 stages of AI development. Retrieved from: <https://www.youtube.com/watch?v=AK5EwG62hx8>, (accessed 1 Sept 2023).
- Anon2, (2023). Unveiling the 10 Stages of AI: What You Need to Know NOW! Retrieved from <https://www.youtube.com/watch?v=AK5EwG62hx8&t=4 s> (accessed 20 Sept 2023).
- Aslani, S., & Jacob, J. (2023). Utilisation of deep learning for COVID-19 diagnosis. *Clinical Radiology*, 78(2), 150-157.
- Brugali, D., & Scandurra, P. (2009). Component-based robotic engineering (part i). *IEEE Robotics & Automation Magazine*, 16(4), 84-96.
- Brugali, D., & Shakhimardanov, A. (2010). Component-based robotic engineering (part ii). *IEEE Robotics & Automation Magazine*, 17(1), 100-112.
- Cho, H., & Nam, T. J. (2023). The story of Beau: Exploring the potential of generative diaries in shaping social perceptions of robots. *International Journal of Design*, 17(1), 1-15.
- Darvish, K., Penco, L., Ramos, J., Cisneros, R., Pratt, J., Yoshida, E., ... & Pucci, D. (2023). Teleoperation of humanoid robots: A survey. *IEEE Transactions on Robotics*, 39(3), 2706-2727.
- De Backer, P., Van Praet, C., Simoens, J., Loes, M. P., Creemers, H., Mestdagh, K., ... & Mottrie, A. (2023). Improving Augmented Reality Through Deep Learning: Real-time Instrument Delineation in Robotic Renal Surgery. *European Urology*, 84(1), 86-91.

- Gartner (2023). *What's New in the 2023 Gartner Hype Cycle for Emerging Technologies*, Gartner Inc. Retrieved from <https://www.gartner.com/en/articles/what-s-new-in-the-2023-gartner-hype-cycle-for-emerging-technologies>, Accessed 6<sup>th</sup> September 2023).
- Hamilton, J.R. & Maxwell, S. (2023). Artificial Intelligence (AI), Rio Tinto and Firm Leading-Edge AI Competitiveness Model. *Proceedings 23<sup>rd</sup> International Conference on Electronic Business*, National Chung Cheng University, Chiayi, Taiwan (physical meetings) and University of Hong Kong, S.A.R. China (virtual meetings), (pp. 1-8), Chiayi, Taiwan, 19-23 Oct.
- Hamilton, J.R., Ramanujam, R., Tee, S., & Underdown, M. (2020).. Business Competitiveness: Building and Applying the 3Cs and the Strategic Change Matrix across COVID-19. *Global Journal of Science Frontier Research: I (Interdisciplinary)*, 20(5), 19-49.
- Helfrich, T. (2022 May). *Why robotics and artificial intelligence are the future of mankind*. Forbes Technology Council. Retrieved from: <https://www.forbes.com/sites/forbestechcouncil/2022/05/31/why-robotics-and-artificial-intelligence-are-the-future-of-mankind/?sh=7b7043751689>, (accessed 1st September, 2023).
- Hua, M., & Raley, R. (2023). How to Do Things with Deep Learning Code. *Digital Humanities Quarterly*, arXiv preprint arXiv:2304.09406, 1-13. Retrieved from <https://arxiv.org/pdf/2304.09406.pdf> (accessed 1 Sept, 2023).
- Iglesias, I., Sanchez, A., & Silva, F.J.G. (2024). Robotic path compensation training method for optimizing face milling operations based on non-contact CMM techniques. *Robotics and Computer-Integrated Manufacturing*, 85( Feb) 2024, 102623, 1-12.
- Ji, S., Yang, X., & Luo, J. (2023). A Survey on Deep Learning for Symbolic Music Generation: Representations, Algorithms, Evaluations, and Challenges. *ACM Computing Surveys*, 56(1.7), 1-39.
- Lee, K. M., Krishna, A., Zaidi, Z., Paleja, R., Chen, L., Hedlund-Botti, E., ... & Gombolay, M. (2023, March). The effect of robot skill level and communication in rapid, proximate human-robot collaboration. *Proceedings 2023 ACM/IEEE International Conference on Human-Robot Interaction* (pp. 261-270)., Stockholm, Sweden, 13<sup>th</sup>-16<sup>th</sup> March.
- Legun, K., Burch, K. A., & Klerkx, L. (2023). Can a robot be an expert? The social meaning of skill and its expression through the prospect of autonomous AgTech. *Agriculture and Human Values*, 40(2), 501-517.
- Li, J., Fang, Q., Dong, M., Rong, X., Jiang, L., & Jiao, R. (2023). Reconfigurable muscle strength training robot with multi-mode training for 17 joint movements. *Journal of Bionic Engineering*, 20(1), 212-224.
- Liu, Y., Wang, J., Cai, W., Carlson, B. E., Lian, J., & Min, J. (2023). A thermo-metallurgical-mechanical model for microstructure evolution in laser-assisted robotic roller forming of ultrahigh strength martensitic steel. *Journal of Materials Research and Technology*, 25(July-Aug), 451-464.
- Lyu, G. & Brennan, R.W. (2024). Evaluating a self-manageable architecture for industrial automation systems. *Robotics and Computer-Integrated Manufacturing*, 85(Feb), 102627, 1-14.
- Mclay, R. (2018). Managing the rise of Artificial Intelligence. *Human Rights Commission*, 1-55.. Retrieved from <https://tech.humanrights.gov.au/sites/default/files/inline-files/100%20-%20Ron%20McLay.pdf> (accessed 1st Sept 2023).
- Moshayedi, A. J., Reza, K. S., Khan, A. S., & Nawaz, A. (2023). Integrating Virtual Reality and Robotic Operation System (ROS) for AGV Navigation. *EAI Endorsed Transactions on AI and Robotics*, 2(1), e3-e3.1-15.
- Ojstersek, R., Buchmeister, B., & Javernik, A. (2023). The importance of Cobot speed and acceleration on the manufacturing system efficiency. *Procedia Computer Science*, 217, 147-154.
- Perez-Villeda, H., Piater, J., & Saveriano, M. (2023). Learning and extrapolation of robotic skills using task-parameterized equation learner networks. *Robotics and Autonomous Systems*, 160, 104309. 1-11.
- Petrescu, M., & Krishen, A. S. (2023). Hybrid intelligence: human-AI collaboration in marketing analytics. *Journal of Marketing Analytics*, 11, 263-274.
- Semeraro, F., Griffiths, A., & Cangelosi, A. (2023). Human-robot collaboration and machine learning: A systematic review of recent research. *Robotics and Computer-Integrated Manufacturing*, 79, 102432, 1-16.
- Singh, K. J., Kapoor, D. S., Abouhawwash, M., Al-Amri, J. F., Mahajan, S., & Pandit, A. K. (2023). Behavior of Delivery Robot in Human-Robot Collaborative Spaces During Navigation. *Intelligent Automation & Soft Computing*, 35(1), 795-810.
- Soori, M., Arezoo, B., & Dastres, R. (2023). Artificial intelligence, machine learning and deep learning in advanced robotics, A review. *Cognitive Robotics*, 3, 54-70.
- Strolin, S., Santoro, M., Paolani, G., Ammendolia, I., Arcelli, A., Benini, A., ... & Strigari, L. (2023). How smart is artificial intelligence in organs delineation? Testing a CE and FDA-approved Deep-Learning tool using multiple expert contours delineated on planning CT images. *Frontiers in Oncology*, 13, 1089807, 1-13.
- Wang, B., Zhou, H., Li, X., Yang, G., Zheng, P., Song, C., ... & Wang, L. (2024). Human Digital Twin in the context of Industry 5.0. *Robotics and Computer-Integrated Manufacturing*, 85, 102626, 1-25.
- Wang, W., Guo, Q., Yang, Z., Jiang, Y., & Xu, J. (2023). A state-of-the-art review on robotic milling of complex parts with high efficiency and precision. *Robotics and Computer-Integrated Manufacturing*, 79, 102436, 1-35.
- Wen, X., Qian, Y., Lian, X., Zhang, Y., Wang, H., & Li, H. (2023). Improved genetic algorithm based on multi-layer encoding approach for integrated process planning and scheduling problem. *Robotics and Computer-Integrated Manufacturing*, 84, 102593, 1-14.
- Zheng, C., An, Y., Wang, Z., Qin, X., Eynard, B., Bricogne, M., ... & Zhang, Y. (2023). Knowledge-based engineering approach for defining robotic manufacturing system architectures. *International Journal of Production Research*, 61(5), 1436-1454.

## Towards Understanding University Governance within Australia

Stephen J. Maxwell <sup>1</sup>  
John R. Hamilton <sup>2,\*</sup>

\*Corresponding author

<sup>1</sup> Researcher, Doctor, James Cook University, Cairns, Australia, Stephen.Maxwell@my.jcu.edu.au

<sup>2</sup> Adj. Chair Professor, James Cook University, Cairns, Australia, John.Hamilton@jcu.edu.au

### ABSTRACT

The shift towards a corporate model for universities and the role of technology has shifted the power structures and operations within universities. In this paper, we examine the university governance changes and structures and how these have shifted the internal focus of those institutions. Historical arguments that the use of technology would reduce the administrative workload, yet this is not the realized case. To explain this failure, it is critical that the current modes of governance be examined, and this will then form the basis for further studies into the role of internal stakeholders in failing to control the growth in the bureaucratic society that dominates modern universities. We argue that there is a failure in governance as agents and stakeholders have no intrinsic control and oversight, and all decisions are made based on spreadsheets and public perceptions rather than in the best interest of the organization.

*Keywords:* university board, bureaucracy, for profit, for good, government, hierarchy, network, education.

### INTRODUCTION

Governance systems within universities have been at a critical point of failure since reforms that sought to statutory regulate boards and the commercialization of institutions (Akroyd & Akroyd, 1999), a process that has led to over-bureaucratization. If your local School had four teachers and 15 office staff you would call for institutional reform or its closure. Similarly, how can there be tolerance for a university with 400 teachers and 1500 administrators? The answer is to be found in the lack of transparency, such that a culture of nobody fundamentally knows what anybody actually does, be that the council, the academy, or even the bureaucrats themselves. What is often referred to as the march of the left through the institution is, in reality, a deflection from the underlying causal factor of the decline that allowed that march to occur: the rise of the bureaucratic institution and deliberately designed governing boards focused on "for profit" and not "for good". However, changes within intuitions have a political dimension, and this is especially the case with the university sector in Australia. All university powers are legislatively handed to the institution's governing body, usually referred to as the University Council (Alt. Senate), which has absolute responsibility for oversight, strategic planning and financial accountabilities (Pelizzon et al., 2022).

One of the problems of university governing bodies is the lack of skill in relation to the primary and statutory goals of the University; instead, there has been a focus on appointing individuals who have commercial experience or social kudos (Pelizzon et al., 2022). This creates a dichotomy where the function and goals of the institution are replaced with executive decisions based on cost accounting rather than the impacts these academic decisions may have on the long-term academic standing and reputation of the institution. Arguably, the decline in many institutions in terms of traditions, international standing and student and staff experience is an actual reflection of this disconnect (Pelizzon et al., 2022). Furthermore, Australian universities have undergone significant reforms over the last half-century, all of which reflect a fundamental shift and realignment of the place of the University in society as market citizens (Jayasuriya, 2013). This involves universities committing to social needs that include promoting political projects, such as social mobility, which are unrelated to the universities' core mission of education and research (Jayasuriya, 2013). However, university governing bodies fail to understand that the desires and wishes of the bureaucratic systems are often used to again to the function and goals of the institution such that there is a "distinctly unrealistic view of the existing internal organization of universities" (Akroyd & Akroyd, 1999, p. 9).

In this paper, we broadly define governance and examine its dimensions and the role of governance in terms of the core mission of the University is reviewed. We then review how Australian Governments have mediated change in higher education boards from the start of the modernization in the 1960s. Revised hypnotized governance operational priority models for universities are presented premised on Harman and Treadgold (2007). Finally, we conceptualize the operational governance within universities.

### LITERATURE REVIEW

Governance arose from the Depression era, where the great losses led to the call for reforms where there was to be a separation of ownership from the control structures within companies. Owners who had legal ownership over companies needed to have levels of oversight of organizational controlling managers (Berle & Means, 1932). This separation can be difficult to achieve,

and it is the core role of modern governance practice to regulate the self-organizing networks within an organization (Gjaltema et al., 2020). At its core, the function of governance is the central organizing framework of oversight that regulates the behaviour of an institution (Robichau, 2011).

While there are different modes of governance, within Australian Universities, there are fundamental principles of governance that are universal in application that are applied to those who sit on boards, and these can be summarized:

1. *Act solely in the interests of the institution taken as a whole, having regard for its objects;*
2. *Act in good faith, honestly and for a proper purpose;*
3. *Exercise appropriate care and diligence;*
4. *Not improperly use their position to gain an advantage for themselves or someone else, and*
5. *Disclose and avoid conflicts of interest (Nelson, 2003, p. 46).*

However, governance in terms of application has many dimensions, and how boards are designed, and the policy framework and ethos under which they are applied vary significantly depending on the emphasis given to any governance dimension. In academic institutions, the governance systems have a dimension of power, and historically, the involvement of the Academy, students and alumni had the effect of constraining the upper management to make significant changes to course offerings and faculty structures. More recently, the shifts toward the corporatization of universities have seen a shift in how institutional actors engage. This shift has seen those in high-level administrative roles and external stakeholders claiming authority over subordinate actors and dominating the University's operational direction (Karp, 2020). Therefore, governance has an important role in how power relations within organizations are negotiated, and as such, defining what is meant by governance and who has that statutory responsibility has enormous operational implications for an institution.

### **Defining Governance**

The modern conception of institutional governance arose in the 1980s, initially as a means of managing rampant bureaucracy and ensuring transparency over the era of public asset privatization (Ruhanen et al., 2010). More recently, governance can be categorized into three categories: the first is political sciences governance (Ruhanen et al., 2010; Barbazza & Tello, 2014); the second is corporate governance (Ruhanen et al., 2010); and the third is institutional governance (Barbazza & Tello, 2014). This divergence in the definition of governance makes the term usage multidimensional, and what is considered a concern for one organization may not rate at another, making governance institutionally unique. However, changes in the meaning of the dimensions of governance and interdisciplinary variation in values and ethics have led to a level of perplexity in understating what is and is not a matter for those charged with organizational governance (Ruhanen et al., 2010).

Political science governance is heavily weighted with themes of accountability, participation, authority, regulation and decentralization (Barbazza & Tello, 2014). This is reflected in the definition of governance from the European Commission (2003, p. 3) - "The rules, processes, and behaviour by which interests are articulated, resources are managed, and power is exercised in society" and the World Health Organisation (2007, p. 3): "Ensuring that strategic policy frameworks exist and are combined with effective oversight, coalition building, regulation, attention to system-design and accountability".

Corporate governance has traditionally focused on transparency, shareholder rights, leadership and innovation (Barbazza & Tello, 2014) and practised within a context guided by the underlying principles of shareholder theory, mirroring stakeholder theory in governance in a practical sense and agency theory. Both theories have a convergence in the desire of the organization to achieve defined organizational goals (Hemphill et al., 2021). However, the current trend in corporate governance is towards *stakeholder capitalism*, which has a significantly reduced focus away from core operations and profitability to the legal, ethical, economic, and political considerations that revolve around contemporary social issues. Fundamentally, the corporate concept of agency and stakeholder interests are usurped by community activist-driven directives. In particular, the necessity to define the boundaries of these legal, economic and political considerations within companies, return the public policy leadership role to government institutions and refocus on creating long-term sustained value (Hemphill et al., 2021).

Unlike governance in the corporate and political spheres, institutional governance is usually dictated by the whims of statutory authorities, which have become entrenched; this is the case with Australian universities (Pelizzon et al., 2022). Notwithstanding regulatory requirements, in effect, most institutions such as universities act with complete autonomy outside maintaining the required standards for accreditations where necessary for operations and meeting industry-academic standards; there is a great deal of scope for boards to deviate away from the institution's core governance responsibility and follow the corporate world into the malaise of allow *stakeholder capitalism* (Hemphill et al., 2021), only in a way which is more insidious because of the lack of external redress open to stakeholder in the corporate world. This unaccountable *stakeholder institutionalism* further empowered the bureaucracy to set and enforce intuitional operational boundaries, even if this means the destruction of organization capabilities (stakeholder interest) and redefining workplace ethos and cultural norms that may limit what was once considered acceptable, or even traditional, the institutional values (agent interest) such as free speech limitations. This will be discussed later in the modern Australian university context.

### **Governance Dimensions**

What are considered the dimensions of governance are as divergent as the definitions surrounding the term (Ruhanen et al., 2010; Barbazza & Tello, 2014). However, there are three primary divisions with the dimensions, and these are generally shared

between studies, although the terms may vary (e.g. *Generating Information/Intelligence* (Barbazza & Tello, 2014) = *Knowledge Management* (Ruhanen et al., 2010)). The first set of dimensions, the core principles, contain what is accepted as universal, and these underpin the organization's ethos, such as ethics and anti-corruption (Table 1). The second set of dimensions covers functions of governance; these include accountability, regulation, and strategic policy design (Table 1). The third set of governance dimensions relate to outcomes and include risk management, equity, and quality (Table 1). While the dimensions may cross over between different occupational cohorts, how each of these cohorts rates the importance of each dimension varies.

In order to effectively define what governance is, the terms for dimensions used in governance often have fundamental differences in meaning (Barbazza & Tello, 2014). To overcome these vicissitudes in definition, those defining the dimensions of governance, an organization must do so in terms of the ideal state of governance that is particular to them in terms of formalizing their dimensions. Those working in the healthcare sector nominated core principles of control of corruption, ethics and integrity and the rule of law as key core principle dimensions for the health sector. In tourism, the rule of law was followed by quality by ethics and integrity, human rights and democracy (Ruhanen et al., 2010; Barbazza & Tello, 2014). Interestingly, control of corruption was not seen as a priority within the tourism governance context, while both health and tourism governance studies reveal that conflict prevention and public good were not high governance considerations (Ruhanen et al., 2010; Barbazza & Tello, 2014). However, these differences in governance reflect the growing effect of stakeholder capitalism, where governance priorities are amended to reflect the vagrancies of the current cultural zeitgeist.

While the boards do not rate *democracy* as an important issue, stakeholder capitalism means that while governance is explicit, it is implicit in all board decision-making processes. The common call for "Democratic Governance" is inherently designed to give the greatest representation to community advocates (Stenling et al., 2023). The problem with appointing these voices is the distraction and focus of board decisions away from the core business (Stenling et al., 2023). At the same time, the application of *Organizational Adequacy/System Design/Structure* in governance is often contextualized with the decentralization of the governance structures within the organization (Ruhanen et al., 2010; Hai and Ahn, 2022). Fundamentally, within the modern university context, there is a reflection of a global move to shift organizational governance down into the bureaucratic system (Hai & Ahn, 2022).

Decentralization invariably leads to the importance of the need for meaningful *Generating Information/Intelligence* (Ruhanen et al., 2010; Barbazza & Tello, 2014). However, the decentralization of governance generates the need for bureaucratic oversights and reporting to the governing bodies that have abrogated those tasks, further generating information (Ruhanen et al., 2010; Barbazza & Tello, 2014). It is this rise in information that may lead to unintentional "busyness", a consequence of which is the drowning of governing boards in paper, leading to a loss of control of the primary oversight functions of the integrity of academic staff appointments, student admission levels, teaching content and methods quality controls, standards control for courses under external obligatory quality standards, organizational priority setting, and funding allocation within amounts available (Hai & Ahn, 2022).

The rise of stakeholder capitalism has led to a shift away from the best interest of the organization as a priority in the decision-making processes, and this leaves financial and social risk protection, sustainability and quality as matters of least concern for modern boards (Ruhanen et al., 2010; Barbazza & Tello, 2014). This approach has meant that for decades, university boards have relied on administrators to provide information on themselves to fulfill the boards' role as bureaucratic monitors (McCormick & Meiners, 1988; Hai & Ahn, 2022). However, institutional agents are made accountable for their bureaucratic decisions because of this information generation and reporting process and the lack of external accountability of the internal intuitional funding models (Hai & Ahn, 2022).

### **AUSTRALIAN UNIVERSITY GOVERNANCE AND SHIFTS IN FEDERAL GOVERNMENT POLICIES**

Government reforms have significantly impacted the governance structures within the university sector. While early reforms targeted student access, later policy changes resulted in structural reforms that have changed and regulated the composition of boards, which affected the ethos of Australian university governing bodies. The governance of Australian universities can be compartmentalized into two divisions. First, there is the higher governance, with statutory obligations, which is the focus of this review (Pelizzon et al., 2022), and second, the internal processes and oversights interwoven into the bureaucracy.

#### **The University Wars**

The 1960s was a particular time in our history when disestablishmentarianism became much of the focus for students and academics across the Western world. There was considerable unrest on university campuses with protests and conflict (Vietnam War), the rise of the women's movement, and a culture of sexual exploration and deviance. The governance systems in universities during this period saw a marked shift in internal power structures in dealing with historically disruptive student misconduct in particular. It can be argued that it was the institutional reaction by the governing boards that allowed the necrocracy to ascend in terms of control of campus behaviour, which has had historical repercussions in how universities are operated in the modern era.

This disruption was met with an unsympathetic intolerance leading to open violence on campus as administrators using force sought to control the institution (Sherry, 1966). However, this created a break between the protection of free speech and

academic freedom *versus* the influences of partisan political groups, making the definition of what is appropriate behaviour on a campus a matter for bureaucratic decision-makers:

*The regulation and control of the behavior of members of the university community through the exercise of administrative rulemaking authority is beset with unusual difficulties that seen inhere in the nature of the intuition (Sherry, 1966).*

In terms of governance, the first principle must be that of illegal conduct, on or off the campus, a matter for the external legal authorities (Sherry, 1966). However, the concept of appropriate contact in the face of the disorder on campus was a matter of contention within the bureaucratic system; what is considered appropriate action can be addressed without recourse to the governing body (Sherry, 1966). Notwithstanding, Sherry (1966) provided three core principles of governance in terms of misconduct: 1) the exercise of discipline must not be arbitrary; 2) standards of due process must be transparent; 3) its scope is conventional institutional boundaries clearly defined. Furthermore, Sherry (1966) argued that there needed to be a clear distinction between the rules and regulations regarding the innate rights of the student (e.g. free speech) and those that are created to protect legitimate university interests (e.g. cheating). Those rights granted to students are a matter of university bureaucratic policy, and interdiction and rules are a reflection of a fount of house-level bureaucrats' concept as to the appropriate limits on forbearance and discretion, and this importantly defines limits of the innate rights of students based on an individual's belief system. This shift in selectivity has held through time and is an anathema to good governance practice.

*University rules and regulations ... [must] not as restraints upon the expression unpalatable ideas but only as shields to be lifted against the acts who unfaithful to the traditions of scholarship, are destructive ideals of learning and the means by which they may be attained (Sherry, 1966, p. 39).*

How the fallout from the wars resulted in a new dynamic in the interaction between the Academy, the councils and the bureaucracy has had a profound influence down the decades and the subsequent shift in governance responsibilities in terms of misconduct.

### **1970 Whitlam Reforms**

By 1974, the Federal government had taken full responsibility for capital and recurrent funding of public universities (Mahony, 1991). However, this government's largess came with increased oversight and eventual loss of autonomy (Mahony, 1991). The historically independent *Australian Universities' Commissions* and additional commissions for the other tertiary education sectors were lost to the federally controlled *Commonwealth Tertiary Education Commission* (Mahony, 1991). However, the reforms that were to come were not unexpected, as governments sought to hold the University accountable in a novel way: how it meets the needs of the changing society:

*While you are funded as you are, you can demand no blank official cheque which ignores other priorities and needs. You cannot dismiss the changing needs of society which you serve and which, in its turn, sustains and accepts you (Baume, 1983, p. 3).*

What is surprising after these comments was that it was not the conservative Minister Baume that reformed the higher education sector that was left to the left.

### **1989 Dawkins Reforms**

In 1988, the Federal Government issued a White Paper (Dawkins, 1988), which argued that universities and their governance models were not fit for purpose and that there needed to be fundamental structural changes to the functioning of universities. Vice-Chancellors were to be granted the title of Chief Executive Officer, and this reflected the shift to a "for profit" model, where they would be more entrepreneurial and business-like (Harman & Treadgold, 2007).

The *Higher Education (Amalgamation) Act (1989) Cth.* brought a level of legislative uniformity to the Australian higher education sector. This reform led to the creation of new universities and the amalgamation within the university sector colleges for advanced education, agricultural colleges, nursing schools, art schools and TAFE colleges, with the aim to create the framework for a greatly expanded tertiary sector which belonged to the *Unified National System* (Pelizzon et al., 2022).

The reforms also led to a further but more fundamental power shift in the funding structures of universities, with the Federal Government having a direct influence over universities in return for financial security, effectually dissolving the historical governance structures (*Commonwealth Tertiary Education Commission*) and limiting the size of governing boards, to a recommended 10-15 members, and reducing the academic and student representation on the council (Pelizzon et al., 2022). The Dawkins reforms introduced a new set of oversight and funding bodies with the creation of the *National Board of Employment, Education and Training* (NBEET) with the subsidiary councils with its *Higher Education Council* (HEC) and *Australian Research Council* (ARC), which were all accountable to Dawkins in his capacity as Federal Minister responsible for the *Department of Employment, Education and Training* (DEET) (Mahony, 1991).

### **1995 Hoare Report and the 2003 Nelson Reforms**

The Hoare (1995) and Dearing (1997) Reports argued for a fundamental shift in how universities are governed based on a compact between universities, the government, industry and society. These reports supported implementing more of the



Dawkins (1988) reforms. In particular, the second round of reforms under Nelson (2003) sought to dislodge the collegial membership of the council, thereby removing much of the deliberation and moving governing bodies towards a more corporate executive leadership model (Musselin, 2005). These changes were driven by a lack of confidence in the existing self-governance models of universities at that time. Fundamentally, there was a belief that the university governing bodies lacked the necessary financial skills to operate as "for-profit" institutions (Baird, 2005).

Nelson (2003, p. 15) argued that universities were riddled with "Anachronistic governance arrangements, in which universities have up to 35 Council members and an average of 21, are not conducive to sound decision making". Consequently, the development and introduction of the *Higher Education Support Act (2003) Cth.*, and more significantly in terms of governance, the introduction of the *Commonwealth Grant Scheme*, which imposed *National Governance Protocols* (s33(1.a)) which affected the composition of university governing boards (Pelizzon et al., 2022, p. 21):

1. *Not more than 18 members;*
2. *Two members with demonstrated financial experience (senior private or public sector history);*
3. *One person with commercial expertise (senior private or public sector history); and*
4. *Majority of external independent members (Not a student nor staff- no qualification requirements).*

Notably, the *National Governance Protocols* used the power of the *Commonwealth Grant Scheme* as a blunt instrument to enforce university changes to their governance structures, notwithstanding the State legislation under which they operated (Nelson 2003). This threat to withdraw Federal funding effectively forced changes upon universities irrespective of the statutes under which the University is enabled. The Nelson reforms outline the primary responsibilities of the governing board (Nelson 2003; p. 46):

1. *Appointing the vice-chancellor as the chief executive officer of the institution and monitoring his / her performance;*
2. *Approving the mission and strategic direction of the institution, as well as the annual budget and business plan;*
3. *Responsibility for the sound management of the institution, including responsibility for approving significant commercial activities;*
4. *Defining policy and procedures consistent with legal requirements and community expectations;*
5. *Establishing and monitoring systems of control and accountability, including monitoring any controlled entities;*
6. *Reviewing and monitoring both the management of the institution and its performance as an institution; and*
7. *Managing risk across the institution, including commercial undertakings.*

These responsibilities highlight the shift towards 'for-profit', with a clear shift towards commercialization of the institution. Furthermore, the reforms empowered councils to self-appoint members:

*The institution is to adopt systematic procedures for nominating prospective members of the governing body for appointment by the Governor in Council, the relevant Minister, or the council itself. This responsibility is to be delegated explicitly to a nominations committee of the council. The institution is to publicly nominate at least one preferred candidate for any current or imminent vacancy on the governing body to be appointed by the Governor in Council or relevant Minister (Nelson, 2003, p. 45).*

Fundamentally, the result of these structural changes meant that the governance of universities was placed into the hands of individuals with no knowledge of higher education quality or ethos and who, once appointed, entrenched themselves using internal selection and nomination systems. Consequently, it can be argued that this meant that boards looked outwards at the public perception of the university operations for which they were seen to have responsibility, rather than the internal machinations of the institution, such that on issues of how the Academy was structured, which were all deferred to bureaucratic advice (Tomlinson, 2021). This deferral is not new, with a historical tendency for university governing boards to act as "rubber-stamping agencies" for the vice-chancellor's decisions (Ditzion, 1948). This advice is driven by quantitative metrics such that there is a drive for successful financial "best interest" performance outcomes, irrespective of the impacts on the universities' "particular interests" (Pelizzon et al., 2022).

### **2008 Rudd Reforms**

The newly elected government of Rudd repealed the legitimization and protocols of the previous government, replacing them with the *Higher Education Support Amendment (removal of the Higher Education Workplace Relations Requirements and National Governance Protocol requirements and Other Matters) Act (2008) Cth.* However, most disrepute this reform. Universities have not adjusted their structural composition regarding external membership (Pelizzon et al., 2022). Importantly for governance, the legislated requirement for independence of composition and processes of appoints to the university boards may lead to self-selection mechanisms (Schröder-Turk, 2021).

### **MODERN AUSTRALIAN UNIVERSITY GOVERNANCE**

There are two facets to university governance in Australia: the control and exercise of power by university councils the second is the mode of operational governance the institution operates. These need to be considered independently as the council is seen as a stakeholder guardianship, and the operational governance is that of a professional agency.

### Defining University Council Governance in Australia

Three principal models can be used to explain the types of governance within universities: traditional, stakeholder (trustee) and corporate (business) (Harman & Treadgold, 2007; Table 1). The composition of the modern Australian council often reflects the particular legislation that incorporates the University, and consequently, there has been a legislative shift in how boards are composed, such as those of Nelson (Pelizzon et al., 2022). Pelizzon et al. (2022) defined the role of the University Council to act concerning the statutory defined objectives and function and in the "best interests" of the University, where best interest is defined as the staff in all capacities, students and graduates. However, the Pelizzon et al. (2022) idea of the "best interests" of the University being its members and stakeholders is a historical anathema and is now the "particular interests" and recently the true "best interest" of the institution, from 1989, shifted to its financial position reflected in the sector moving away from the traditional model of governance to one that is corporate. Furthermore, there has been a rise in activism on boards as:

*... members boards of governance see their roles as advocates for particular interests. ... while some members may feel responsibility ... they have an overriding responsibility to act in the best interests of the institution (DET, 1988, p. 102).*

Table 1: The three forms of university governance within Australia and the different aspects of the operation of the institution (after Harman & Treadgold, 2007, p. 19-20).

Institutional Aspect	Governance Model		
	Traditional	Stakeholder	Corporate
Mission Statement	Student Education Research	Student Education Research Community Obligations	Sale of Education Sale of Research Sale of Services
Goals	Ambiguous Contested Inconsistent	Consistent Clear Long-Term Goals	Clearly Stated Non-contested
Organizational Structure	Collegial Hierarchical	Shared Collegial Hierarchical	Managerialist Culture Hierarchical
Size of Council	Medium/Large (15-35)	Medium (up to 22)	Small (7-13)
Council Membership	Insiders > Outsiders Compensated Set Term Range of Skills Range of Experience Staff/Student/Alumni	Outsiders = Insiders Compensated Set Term Diversity Range of Skills Range of Experience Staff/Student/Alumni	Outsiders > Insiders Compensated Skills Tied to Business Ignores Staff/Student Term Varied
Roles of Chancellor	Primarily Ceremonial Chairman of Board	Chairman of Board Joint Asset Manager Shared Leadership	Chairman of Board
Roles of Vice-Chancellor	Sits on Board Presents Decisions of Senate and Other Stakeholders	Sits on Board Joint Asset Manager Shared Leadership	Sits on Board Implements Board Decisions CEO Administration of Board Decisions
Council Organisation	Academic Board Nominated Positions Government Appointments Elected Academy Elected Student Elected Alumni	Independent Committee for Selection Choice of Stakeholder Representation	Nominated by Council Finance and Audit Committee Essential
Government Relationship	Funding Provider Oversight and Control of Boards Macroeconomic Policies Guide Decisions	Works within Policy Guidelines Research Funder	Substantial Autonomy Board Decisions Free of Government Guidelines Conditional Funding
Success Measure	Quality of Student Outcomes Research Output	Quality of Student Outcomes Research Output Community Engagement	Financial Performance Student Numbers Research Output

There is an underlying conflict as board members seek to mediate their "particular interest" with the "best interests" of the University. This can be encapsulated graphically with the board's idea of "best interests" under each governance model (Figure 1). How can there be structural changes in governance within intuitions where there is no external or internal accountability? Furthermore, the idea of self-preservation may explain the reluctance of board members to remove themselves to mediate meaningful change and a more academically balanced university council, hanging on even in the face of demonstrable failures in governance and operational standards. In comparison, the vicissitudes of governance at the highest levels of the University have profound effects on the strategic operations. It is within the halls of the University, away from the hallowed halls of the Chancellery, where institutional governance becomes opaque. For in these halls belongs the world of university bureaucracy, and it was Weber who warned of the dangers of the bureaucratic monster.

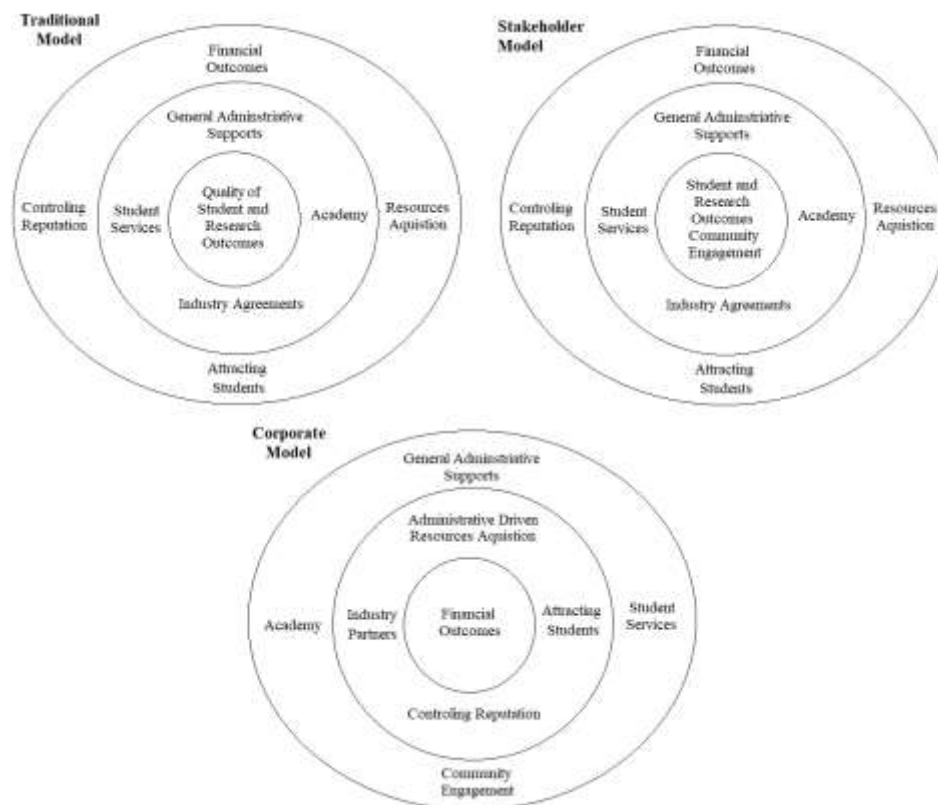

Figure 1: The importance of competing "best interests" of a university board under differing models of council governance (After Harman & Treadgold, 2007).

**Defining Operational Governance in Australia**

University operational governance differs from board governance in that the objectives and the power structures are internal and deal with the functioning within the organization and the interplay of its actors. Purdy (2012) argued that there were two aspects to internal governance and how they are related to the organizational power structure. The first is the sources of power, which encapsulates the authoritative structures, resources, and the level of discursive legitimacy of those within the system (Figure 2). The second is the power arenas, the participants who are making the decisions, the processes and design framework under which they act, and the content that is subjected to oversight (Figure 2). While the sources of power often have defined and clear governance pathways, the power arenas and the functioning systems are opaque and lack clear lines of demarcation of responsibility. Three systems of governance seek to operate and mediate oversight between and within the organizational power structures: networks, hierarchy, and markets.

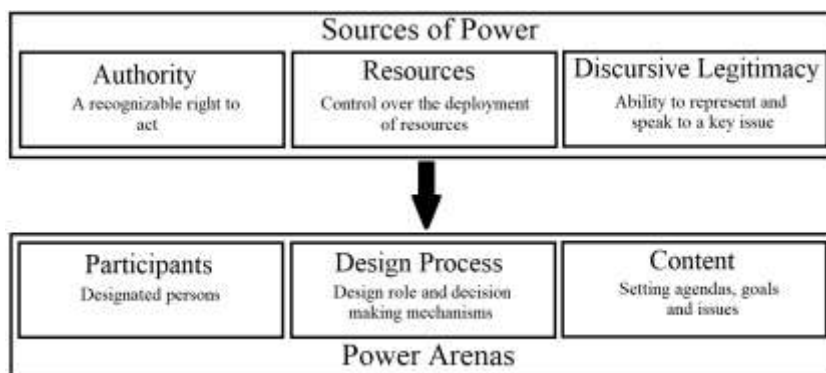

Figure 2: The general operational segments in governance processes (after Purdy, 2012)

Governance networks, in the broad sense, is the collection of diverse actors who create innovation, reciprocity, trust, and self-organization to ensure policy implementation and adherence to procedure (Robichau, 2011; Maron & Benish, 2022). How the oversight process that is in place to ensure that the roles of governance are being achieved has required external oversight, which then threatens the internal processes that the network has created (Maron & Benish, 2022). However, the nebulous nature of networks often leads to accountability failure, and demonstrating who was responsible for the failure in governance can, therefore, be problematic and fraught with internal conflict (Robichau, 2011). In order to mitigate this potential governance failure, the concept of institutional 'meta-governance' was developed to provide higher level oversight, and this may take three forms (Maron & Benish, 2022): 1) Participant-Governed Networks, these have an internal and participatory framework with limited external oversight; 2) Lead Organisation-Governed Networks, with a centralized governance system that is internally directed and this system has limited external oversight; and 3) Network Administrative Organisations, these have a centralized and external systems of oversight. However, only the Network Administrative Organisations have the sole focus of managing governance systems through third-party oversight; both Participant-Governed Networks and Lead Organisation-Governed Networks involve the participants in the governance and management systems. However, these can lead to power tensions and conflict (Maron & Benish, 2022). How a governance network is positioned and operates within an organization is driven by those who have design control, and this in itself creates questions on who defines what policy implementation or organization service delivery oversights are needed, and this may differ from the oversight of day-to-day operations or strategic planning. The top-down governance model has been questioned regarding its ability to cope with societal and technological changes that organizations often undergo (Bogason & Musso, 2006; Klijn, 2008). Hierarchical governance has two primary facets (Lynn, 2011): it is the manifestation of the institutional authority to direct change and ensure that processes and practices conform with those that the higher powers deem necessary, and 2) it is the principles of accountability that the institution has expressed that are used to monitor networks. One of the major problems with the hierarchical model is the often-excessive layering of power that generates unresponsive and inefficiencies (Robichau, 2011), as well as creating a culture of buck-shifting of responsibility to those up and down the power structural chain. Internal governance systems that are driven by markets seek economy, efficiency and effectiveness through the collaboration of both internal and external actors. This method outsources responsibilities and activities such that flawed institutions can cover their incompetencies and failures through the use of external actors (Robichau, 2011).

## DISCUSSION

Much has been made that Australian universities have been corporatized (Pelizzon et al., 2022). This corporatization has created a structural dichotomy: bureaucracies are anathema to the corporate sector. It is pure bureaucratic irrationalism to argue for business models to dictate institutional operations, course structures and offerings and, simultaneously, resolve to retain systems of governance that do not mirror the corporate ethos (Pelizzon et al., 2022). It is fuelling the desire for corporatism and competition within the university sector and the growth of a bureaucracy that has directly caused those institutions to have an inability to manage funds; this, coupled with a lack of transparency and accountability in the university sector, are the causal factors for structural decline (Pelizzon et al., 2022). The current operational model for universities is not sustainable, and as bureaucratic rule has become structurally all-pervasive throughout institutions, there will be consequential failings in governance standards as the opacity level of bureaucratic accountability increases to the point of being dictatorial (Fleming, 2021; Vodeb et al., 2022).

*... the more he enquired about the financial and staffing circumstances under which the School as now operating, the more hostile his working environment became (Tregear et al., 2022, p. 47).*

The bureaucracy and the Academy also differ in knowledge acquisition goals; historically, the Academy produced knowledge and was rewarded through recognition, but this has shifted, driven by the commodification of knowledge (Vodeb et al., 2022). Modern universities seek to judge the academy knowledge production not so much on its production of individual academic recognition but rather as an output from which competitive decisions are based (Vodeb et al., 2022). Compassion and stratifications of knowledge are numerically classified, and rankings are derived. Furthermore, these metrics affect promotion and awards that are used to elevate status within institutions. This generates pseudo-academics who are more akin to professional representatives whose task is to profligate the importance of ties between the University and industry, and this reinforces the corporatization of the institution and relegates the Academy to an institutional knowledge factory (Vodeb et al.,

2022). The problem is that these pseudo-academics have become the instrument of bureaucratic control. The work of the Academy is recontextualized from good work and excellence to economic efficiency and value for money (Fleming, 2021). A consequence of this is the loss of rigor in the Academy, with the idea of any criticism within the college personalized and those challenging academics deemed untrustworthy to be weeded out (Tregear et al., 2022).

*Universities are supposed to be bastions of free speech and forthright opinions, yet our research has shown that confidentiality clauses may have been used not only to avoid dirty laundry being aired in public but now are just common practice in higher education ... the cold wind of gagging staff and stifled debate, much in the public interest, is going through the halls of our bastions of enlightenment and tolerance* (Mason in Tregear et al., 2022, p. 49).

A recent integrity study into the operations of South Australian Universities found that academic staff within the institution described the culture as one of monetization and corporatization (Baum et al., 2022). Those academics who work in higher education in Australian Universities often describe the campus atmosphere as toxic (Smyth, 2017; Baum et al., 2022). This toxicity is not new, with dissatisfaction with the University at the changes instituted by Dawkins in the late 1980s, which led to nationwide standardization of instrumental performance standards and the subsequent shifting of collegial control away from the Academy to bureaucrats that dictate workloads and the level of autonomy that academics have (Tregear et al., 2021). Importantly, the shift to private sector corporations from the traditional role of an institution of public good has refocused the attention away from a drive and culture of excellence to one of competitive pressure and mediocrity (Baum et al., 2022).

*Universities sing the song of meritocracy but dance to a different tune. In reality, they will do everything to reward and protect their most destructive, abusive and uncooperative faculty* (Dumitrescu in Tregear et al., 2022, p. 46).

The corporatization of Australian Universities is not a new conception, having the capacity and powers of a *sui generis* corporation and is exempt from the Corporations Act for the purposes of S57A and are required to be registered under the Charities Act for the purposes of advancing higher education (Pelizzon et al., 2022). However, the idea of the University functioning as a corporate entity is in contrast to the most recent University of Sydney Act (1989) NSW refocused the goals and function of the institution on its educational and research functions, declaring explicitly as auxiliary: service to the community, generation of revenue and commercial functions (Pelizzon et al., 2022). It is worth reminding vice-chancellors that the Academy is under an existential threat from the perceived primary role of *Chief Executive Officer*, with the title *President of the Academy* arguably seen as more ceremonial than functional (Pelizzon et al., 2022). In particular, the corporatization of universities has five aspects (Cary and Watt 1999):

1. Research has moved towards meeting industry demands;
2. Financial considerations drive decision-making;
3. The use of corporate cultural practices by the university bureaucracy;
4. The redesign of the curricula and degree structures to meet the needs of industry; and
5. The focus on partnerships between universities and industry rather than teaching and research.

Therefore, it is not surprising, given the dominance of business and activists on university board composition and the governmental policy move towards university corporatization, that institutional governance priorities mirror those governing corporate governance. This results in a focus away from the core business of the University, which is the Academy that can be explained is driven by assurgency stakeholder capitalism. The Academy has been reduced to service providers to industry via students, with their role in governance reduced to obsolescence, and they are no longer the core focus of the institution. All of this results in the commodification of the Academy and the loss of those disciplines, such as classics, which are never cost-neutral, to be dissolved.

*Whether you dwell in the abstract or the ideal, there is but one essential feature if the institution: "the faculty is the college"* (Barrett, 1963, p. 170).

The modern Australian University exhibits the worst kind of management style, that of managerialism, or the implementation of market-based realities on the Academy, while at the same time normalizing the bureaucracy's public sector approach to administration (Vodeb et al., 2022). This gives rise to a culture where spreadsheets dictate the evaluation process of academics, and consequently, universities become institutions governed by spreadsheets (Vodeb et al., 2022).

Governance is intrinsically the control and oversight of agents by stakeholders, but boards of governors as principals should have a strictly hands-off approach to operations. However, within universities, this is not the case. One example is the self-determination of remuneration by agents, which is structured to reward themselves and promote their interests over that of the University (Boden & Rowlands, 2022). This, in part, creates a bureaucracy whose actors are intrinsically rent seekers with unjustifiable remuneration at a level that would be necessitated to retain and compensate staff to fulfill the roles with competence (Boden & Rowlands, 2022). Boden and Rowlands (2022) called for a renewal of governance, but who appoints the governors, ah there is the rub. There needs to be a fundamental shift in the meta-governance practices away from "who" towards a structural force that shapes actors' behaviour rather than allowing the perpetuation of the normative state (Gjaltema et al., 2020). For governance's sake, the Academy be separated from the professionals.

## CONCLUSION

Australian universities are struggling under the weight of a corporate model for educational delivery, while at the same time seeking to maintain the bureaucratic systems that are not held to the same performance standards. The shift to a corporate model and the use of governing boards to virtue signal rather than focus on the internal operations of the institution, which is led by the bureaucratic systems that simply file reports and this has resulted in a vacuum in the operational governance of the institutions. At best, internal governance is to be considered a network of power structures each with a common theme of self-preservation even if that comes at a cost to the organization. Until there is a root and branch reform of the operational structure of the universities, and especially the appointment of an individual with direct responsibility for organizational governance, and the powers to act when failures are found, there is little hope of real change to the status quo.

## REFERENCES

- Ackroyd, P., & Ackroyd, S. (1999). Problems of university governance in Britain. Is more accountability the solution? *The International Journal of Public Sector Management*, 12(2-3), 171-185.
- Baird, J. (2005). Beyond professionalism: enhancing the governance culture for Australian university governing boards. 27<sup>th</sup> *EAIR Forum*, Riga, Latvia.
- Barbazza, E., & Tello, J.E. (2014). A review of health governance: definitions, dimensions and tools to govern. *Health Policy*, 116(1), 1-11.
- Baum, F., Dollard, M., Fisher, M., Freeman, T., & Newman, L. (2022). The corporate university and its impact on health in Australia. *Social Alternatives*, 41(1), 52-62.
- Baume, P. (1982) in Anwyl, J.E., ed. *University Government Relations, Proceedings of the Conference of University of Governing Bodies*. AVCC, Canberra. 1982.
- Berle, A., & Means, C. (1932). *The Modern Corporation and Private Property*. New York, NY: Macmillan,
- Boden, R., & Rowlands, J. (2022). Paying the Piper: The Governance of Vice-Chancellors' Remuneration in Australian and UK Universities. *Higher Education Research and Development*, 41(2), 254-268.
- Bogason, P., & Musso, J.A. (2006). The Democratic Prospects of Network Governance. *The American Review of Public Administration*, 36(1), 3-18.
- Cary, N., & Watt, S. (1999). *Academic Keywords: A Devil's Dictionary for Higher Education*. London, UK: Routledge.
- Dawkins, S. (1988). *Higher Education, A Policy Statement*, AGPS, Canberra.
- Dearing Report (1997). *Higher education in the learning society: Main Report*. London, UK: Department of Education, Science.
- DET (Department of Education and Training) (1988). *Higher Education: A Policy Statement, Commonwealth of Australia*. Canberra, Australia: Australian Government Publication Service.
- Ditzion, S. (1948). Men Who Control Our Universities The Economic and Social Composition of Governing Boards of Thirty Leading American Universities. *College & Research Libraries*, 9(3), 274-275.
- European Commission (2003). *Governance and development*. Brussels, Belgium: Commission of the European Communities.
- Fleming, P. (2021). *Dark Academia: How Universities Die*. London, UK: Pluto Press.
- Gjaltema, J., Biesbroek, R., & Termeer, K. (2020). From government to governance...to meta-governance: a systematic literature review. *Public Management Review*, 22(12), 1760-1780.
- Hai, P.T.T., & Anh, L. .K. (2022). Academic staff's participation in university governance - a move towards autonomy and its practical problems. *Studies in Higher Education*, 47(8), 1613-1626.
- Harmen, K. & Treadgold, E. (2007). Changing patterns of governance for Australian universities. *Higher Education Research and Development*, 26(1), 13-29.
- Hemphill, T.A., Kelley, K.E., & Cullari, F. (2021). The ascendancy of stakeholder capitalism: What is its meaning for corporate governance? *Journal of General Management*, 46(4), 262-273.
- Higher Education (Amalgamation) Act (1989) Cth*. Commonwealth of Australia, Canberra, Australia: Australian Government Publication
- Hoare Report (1995). *Higher education management Review Committee: Report of a committee of enquiry*. Canberra, Australia: Department of Education, Training and Youth Affairs.
- Jayasuriya, K. (2013). Transforming the public university: Market citizenship and higher education regulatory projects. *ASSA Workshop on Markets And The Modern University ANU 30-31 May 2013*.
- Karp, D.J. (2020). Fixing meanings in global governance?: "Respect" and "protect" in the UN guiding principles on business and human rights. *Global Governance*, 26(4), 628-649.
- Klijn, E. (2008). Governance and Governance Networks in Europe: An Assessment of Ten Years of Research on the Theme. *Public Management Review*, 10(4), 505-525.
- Lynn, L.E. (2011). The Persistence of Hierarchy. In *The Sage Handbook of Governance*, ed. M. Bevir. Thousand Oaks, CA: Sage Publications, pp. 318-336.
- Mahony, D. (1991). Autonomy and the post Dawkins universities. *Education, Research and Perspectives*, 18(1), 14-24.
- Maron, A., & Benish, A. (2022). Power and conflict in network governance: exclusive and inclusive forms of network administrative organizations. *Public Management Review*, 24(11), 1758-1778.
- Musselin, C. (2005). *Change or continuity in higher education governance*. In Bleiklie, I, and Henkel, M., eds., *Governing Knowledge*, Amsterdam, Netherlands: Springer, pp. 65-80.
- Nelson, B. (2003). *Our universities backing Australia's future*. Canberra, Australia: Department of Education, Science and Training,

- Pelizzon, A., Joannes-Boyau, R., Lake, S., Lucas, A., McCallum, A., Noble, D., O'Connor, J., Orr, J., Schröder-Turk, G., Tregear, P., & Vodeb, O. (2022). Australian public universities: A crisis in governance. *Social Alternatives*, 41(1), 17-25.
- Purdy, J.M. (2012). A Framework for Assessing Power in Collaborative Governance Processes. *Public Administration Review*, 72(3), 409-417.
- Robichau, R.W. (2011). Mosaic of Governance: Creating a Picture with Definitions, Theories, and Debates. *Policy Studies Journal*, 39(s1), 113-131.
- Ruhanen, L., Scott, N., Ritchie, B., & Tkaczynski, A. (2010). Governance: a review and synthesis of the literature. *Tourism Review*, 65(4), 4-16.
- Schröder-Turk, G.E. (2021). A Self-Selection Mechanism for Appointed External Members of WA University Councils. *Australian Universities' Review*, 63(1), 34-44.
- Sherry, A.H. (1966). Governance of the University: Rules, Rights, and Responsibilities. *California Law Review*, 54(1), 23-39.
- Smyth, J. (2017). *The toxic university: zombie leadership, academic rockstars and neoliberal ideology*. London, UK: Palgrave MacMillan.
- Stenling, C., Fahlén, J., Strittmatter, A.-M., & Skille, E.Å. (2023). The meaning of democracy in an era of good governance: Views of representation and their implications for board composition. *International Review for the Sociology of Sport*, 58(1), 108-125.
- Tomlinson, M. (2021). Opportunity knocks for WA unis to reset targets since losing foreign student “punchbowl”, *WA Today*. 16 September.
- Tregear, P., Lake, S., Lucas, A., O'Connor, J., Pelizzon, A., & Vodeb, O. 2022 “Enough to make you sick!” Pathological characteristics of the Australian academic workplace *Social Alternatives*, 41(1), 44-51.
- Vodeb, O., Joannes-Boyau, R., Lake, S., Lucas, A., McCallum, A., O'Connor, J., Pelizzon, A., and Tregear, P. (2022). Australian public universities and the destruction of the academic community. *Social Alternatives*, 41(1), 35-43.
- World Health Organization (WHO)(2007). *Everybody's business: strengthening health systems to improve health outcomes: WHO's framework for action*. Geneva, Switzerland: World Health Organization.



## Unravelling Consumer Engagement in Influencer Marketing: An Exploratory UGC Analysis

Yi-Ching Tseng<sup>1,†</sup>  
Pei-Yi Chen<sup>2,†</sup>  
Jing Ren<sup>3,\*</sup>  
Yu-Chen Hung<sup>4</sup>  
Wenting Liu<sup>5</sup>  
Jorng-Tzong Horng<sup>6,\*</sup>  
Li-Ching Wu<sup>7</sup>

\*Corresponding author

<sup>1</sup> National Central University, Taiwan, 109502515@cc.ncu.edu.tw

<sup>2</sup> National Central University, Taiwan, 109502504@cc.ncu.edu.tw

<sup>3</sup> Lecturer, Singapore University of Social Sciences, Singapore, jingren@suss.edu.sg

<sup>4</sup> Senior Lecturer, Singapore University of Social Sciences, Singapore, ychung@suss.edu.sg

<sup>5</sup> Senior Lecturer, Singapore University of Social Sciences, Singapore, wentingliu@suss.edu.sg

<sup>6</sup> Professor, National Central University, Taiwan, horng@db.csie.ncu.edu.tw

<sup>7</sup> Associate Professor, National Central University, Taiwan, nculcwu@gmail.com

† Contributed equally

### ABSTRACT

The sharp increase in the influencer market on social media generates a huge amount of content, including text, audio, images, and video. However, how these contents are used to leverage consumer engagement is still unclear. In this study, we explored the potential usage of natural language processing and various computer vision models in understanding influencer UGC and marketing analysis. Through studying the influencers' textual and visual posts on Instagram, our preliminary findings show that different formats of UGC may impact consumer engagement differently. Our work offers new knowledge on exploring suitable analysis tools for studying the influencer market, and the learned insights on content generation could shed light on enhancing marketing effectiveness in the influencer marketing industry.

*Keywords:* computer vision, consumer engagement, influencer marketing, LIWC, and UGC.

### INTRODUCTION

With a current market value of 10.39 billion USD, an annual 33.4% increase from 2019, influencer marketing on social media is a very young but fast-expanding industry. Social media influencers are individuals who have gained popularity because of their presence and content on social media, such as bloggers, YouTubers, TikTok Live users, and Instagrammers (Aw and Chuah, 2021), and they are cashing in on their popularity to help brands promote goods and services. Today, social media influencers are not just mega-influencers with follower counts in the millions; they could also be micro-influencers with dedicated followers and niche knowledge. They can include both conventional celebrities who first became famous outside of social media as well as those who became famous fully online (Campbell and Farrell, 2020).

In this emerging business model, influencers partner with brands to craft interesting and impactful content that is relevant to their followers. Through the partnership, brands aim to increase engagement via influencers, specifically in light of their interactivity (Farivar *et al.*, 2022; Jun and Yi, 2020). The beauty of this system is that influencers, rather than the brand itself, can be the generators of marketing content, which is usually called User-Generated Content (UGC). A common format of UGC is visual content (e.g., image, video) plus textual content.

To promote a product using visual content such as images, influencers may use objects to express themselves innovatively. Objects often carry symbolic meanings, acting as a metaphor that evokes emotions. Their relationship with the human subjects and other objects in an image can convey meaning and feelings among the readers. For textual content, influencers may have their own writing styles, such as adding more tags, using a personal tone, using long sentences, etc. Despite the proliferation of these practices, it remains unclear how and to what extent the generated content could create social engagement with its target audience, especially by linking to products in different categories. To our knowledge, the bulk of the research on the impact of visual and textual popularity prediction on consumer engagement is still insufficient.

In this study, we seek to leverage a hybrid exploratory analysis using natural language processing and computer vision models to understand influencer-generated visual and textual content. By exploring the impact of image features and textual features on engagement rates, we aim to answer three research questions:

- What kind of image or text could drive a great number of “like” engagements with an influencer’s post?
- What kind of image or text could drive a great number of “comment” engagements with an influencer’s post?
- Compared to human annotation, could a machine outperform in predicting consumer engagement?

By studying the UGC content posted through collaborations between brands and influencers on Instagram for reputation management and special promotions, our work plans to offer new knowledge on exploring suitable analysis tools for studying the influencer market. It also paves the way for enhancing the effectiveness of influencer marketing and providing suggestions for sustainable career development for influencers.

## LITERATURE REVIEW

### **Influencer Marketing**

Brands have gradually abandoned traditional advertising and increasingly use social media influencers to promote their products or services (Janssen et al., 2022). The market value of influencer marketing platforms was estimated to be with an expected expansion at an annual growth rate of 33.4% until 2030 across campaign management, search and discovery, analytics and reporting, and influencer management on popular social media sites such as Instagram, Meta (Facebook), Pinterest, and YouTube (Grand Viewer Research, 2021). When brands partner with influencers, they compensate the influencers for their services, including content creation, posting on their channels, attending events, providing feedback or reviews, or even selling products. In return, influencers may receive a flat fee, commission, free products or services, or sponsorship for content generation in exchange for their promotion on social media. In the partnership, brands use influencer marketing as an effective tool for digital marketing communication, where interactivity and engagement are the core to delivering value (Farivar et al., 2022).

To generate engagement (e.g., like, comment, and share), influencers rely on creative content and interactive features. The content needs to be visually appealing to grab the attention of their followers, such as interesting photos, short videos, and captive captions. The visual inputs spark conversation, and influencers also use hashtags to co-create with other influencers for brands. Using trending hashtags, influencers can reach a wider audience through timely online conversations with other influencers and brand followers. Trendy and attention-grabbing visuals are the key characteristics of posts by Instagram influencers. Visual inputs of interesting and unexpected images serve as a foundation to simulate engagement with followers.

Different social media platforms have varying media formats, purposes, and audiences. In a comparative study of popular social media platforms, Haenlein et al. (2020) found that Facebook tends to have an older audience with lower engagement rates. Twitter supports text-based posts only and is often utilized as a news source. Additionally, both YouTube and Instagram are primarily used for entertainment purposes, as pursuing entertainment value can facilitate the expansion of influence. Given the aforementioned advantages—namely, a younger user demographic, diverse UGC formats, and the potential for easy influence extension—this study opts for influencer marketing posts on Instagram. The aim is to investigate which types of UGC are favored by consumers, with the subsequent goal of enhancing advertising engagement.

### **UGC Analysis in Consumer Engagement**

#### ***Textual content analysis***

Text analysis techniques have been adopted in various applications, including social media engagement (Hung and Guan, 2020). Language and communication styles, including textual features such as post length, structure, personal tones, and word choice, may serve as persuasive cues for consumer engagement on social media platforms. A study by Fan et al. (2023) investigated the top 10 influencers on Sina Weibo, which is the leading microblogging social media platform in China. They suggested that including promotional messages in the post has the potential to boost consumer engagement; however, they did not learn the textual content in depth. Syrdal et al. (2023) used Linguistic Inquiry and Word Count (LIWC) to extract linguistic-based features from the textual post of Instagram, and they found that using words with high authenticity and positive emotions in the post can increase consumer engagement. About the length of the post, these two studies hold different conclusions. Fan et al. argued that longer text provides richer information or incorporates non-commercial messages into a story, leaving a deeper impression on the audience. While Syrdal et al. suggested that longer and more logical posts may discourage audiences from understanding the details.

Although consumer engagement with different cultural backgrounds may give different responses to the length of the post, the textual content has been recognized as an important item for formulating marketing content and strategies. However, how the brand content aligns with the influencer's style, leading to a higher consumer engagement rate, is still worth finer-grained investigations.

#### ***Visual content analysis***

Exploration of the impact of visual UGC (e.g., image, video) is attracting more and more attention with the sharp increase of influencer marketing in the marketing field. However, the grouping amount and diversity of UGC make manual coding annotation hard to handle. The interest in automatic detection, coding, or labeling using computer vision (CV) techniques has

become a hot topic in recent years (Kwon et al., 2022). In principle, CV models, especially deep neural networks, could provide strong support to brand-related visual UGC analysis for marketing applications because CV can automatically analyze the visual content, for example, extract color and texture, detect and classify objects, and classify scenes and themes. Unfortunately, its application is still in the early stages, on either a research or practical level. A possible obstacle is the lack of pre-trained CV models for brand-related visual content. The existing research explores the possibility and performance of using CV models to gain marketing concepts, which can be summarized into three branches:

- Based on low-level features: Kwon et al. (2022) revealed that various patterns of color features (e.g., cool or warm, darkness, saturation, and colorfulness) have been used in B2B and B2C contexts to gain positive eWOM on social media platforms such as Instagram.
- Based on commercial software: A bulk of existing work adopted commercial software, such as the Google Cloud Vision API and Clarifai API. For example, the Google Cloud Vision API has been used to label tourist-generated images and food images to understand the impact of visual content on consumer engagement (Philp et al., 2022). Nanne et al. (2020) verified the ability of Clarifai to analyze images on Instagram. The disadvantage of using commercial software is that developers have little control over the method's design.
- Based on pre-trained CV models: The tested CV model is YOLOv2, but it did not show a promising outcome (Nanne et al., 2020). Unfortunately, other famous CV models like OpenCV, Show&Tell, and generative AI-based ClipCap have not been tested (Vinyals et al., 2015; Mokady et al., 2021).

### **Hybrid analysis**

A small group of researchers has tried to study the ability of combining textual and visual content to predict consumer engagement in influencer marketing. For example, Jaakonmäki et al. (2017) integrated basic textual features (e.g., words and emojis) and visual features (i.e., detected objects) using the Clarifai API. However, they did not learn the text in depth and ignored illustrating the impact of the learned visual features. Nanne et al. (2020) tried one more step to involve topic modeling to group the visual words learned by YOLOv2 and commercial tools; however, they did not study the textual content.

## **DATA CONSTRUCTION**

The goal of this study is to explore the role of user-generated textual and visual content in predicting consumer engagement on social media. We collected UGC posts published by Instagram influencers from a collaboration marketing company. All the influencers' posts are in collaboration with brands. There are a total of 169 UGC posts involving six brand categories: *Apparel, Cosmetics, E-commerce, Food, Hotels, and Watches*. The involved brands are Calvin Klein, Nike, Prada, Shiseido, SKII, Lotte, Burger King, McDonald's, Ritz Hotel, Daniel Wellington, Rolex, etc.

Each UGC post contains images and text. The image content could include the brand product, and the textual content tends to be emotional, often reflecting influencers sharing their personal experiences using the products or expressing gratitude to the brand for the business collaboration. The datasets also encompass basic information about the influencers and their engagement metrics (such as likes and comments), enabling further content analysis and influence assessment. In this section, we will provide a detailed explanation of the dataset's construction and data description.

### **UGC Analysis and Measures**

#### **Textual variables**

Two elements of the textual features are extracted based on the literature review: basic information and linguistic features. Basic information includes the length of the post (*postLength*), whether the product brand appeared (*brandNameAppeared*), and whether the product category appeared (*productCategoryAppeared*). For linguistic features, LIWC is adopted, which is a tool for analyzing linguistic features or emotional tendencies in text based on linguistics and psychology. It aims to provide quantitative and qualitative analysis of textual content (Pennebaker et al., 2001). Existing studies reflected that language and communication styles could be persuasive factors for consumer engagement; therefore, we extracted two main dimensions of linguistic features using LIWC:

- Personal pronouns: The analysis of pronoun categories of influencers' posts can indicate which pronoun categories are used more frequently or less frequently in the text. For example, extensive use of the first-person singular pronouns may indicate an emphasis on personal perspectives, experiences, or emotions. While the use of second-person pronouns may suggest interaction with the reader or providing instructions. In total, six dimensions are learned, including a general pronoun and five sub-categories to indicate the writing style in using different pronouns (as shown in Table 2).
- Psychological processes: Five psychological process categories, including *affective, social, cognitive, perceptual, and physical*, are extracted. Psychological process categories can examine which categories dominate the language elements of the post. For example, the widespread use of *affective* process categories may indicate an emphasis on emotional expressions such as preferences, concerns, or excitement. While *social* process categories may imply a focus on social interaction or interpersonal relationships. The *perceptual* processes, on the other hand, express human senses, including auditory, visual, and tactile senses. The *physical* processes encompass not only bodily structures but also physiological states and sexual orientation.

### Visual variables

Four open pre-trained CV models are used to test the suitability of supporting marketing analysis compared to using manual annotations given by humans. In total, three undergraduate students from the Computer Science discipline were hired to label the images, and the four open pre-trained models are YOLOv5, OpenCV, ClipCap, and Show & Tell. Various evaluation metrics such as BLEU, ROUGE, and METEOR (Vedantam et al., 2015) were adopted to evaluate their performances compared to manual annotations. Considering the potential impact of the influencer's image, we try to compare the detection of key items in an image including humans and objects from 5 dimensions: *#people*, gender of the people (i.e., *woman*, *man*), whether human *face* and other *objects* appeared in the image (the detailed description of the variables is shown in Table 2).

Two labeled samples are given in Figure 1. YOLO and OpenCV are object detection models. They can identify the objects, including persons and items, and also indicate the position of detected objects using different colors of boxes (as shown in Figure 1). While ClipCap and Show & Tell are image descriptions or captioning models with a single sentence. The overall performances can be summarized as follows:

- YOLOv5: It excels at accurately detecting and localizing people but struggles with images containing multiple objects.
- OpenCV: The bounding of the contours of objects is almost completely incorrect, e.g., bounding an area that does not contain any objects, or the accuracy of detecting the precise location of a complete object is quite low, e.g., bounding only one leg of a person. Furthermore, due to the lack of specific classifiers (e.g., a face classifier), OpenCV cannot label the detected objects or generate image descriptions. This misalignment with our research objective.
- ClipCap: As an image captioning model leveraging CLIP (Contrastive Language–Image Pre-training) based on GPT2, it excels at describing relationships between people in images and accurately describing the context of the entire image (e.g., describing the new products on a McDonald's menu), which provides a higher-level understanding of the image content. However, it sometimes cannot determine detailed information about the people and objects.
- Show & Tell: It is capable of describing an image with a single sentence, following the typical sentence structure used by humans to describe images (e.g., "A woman is standing in front of the building"). However, there may be some differences in recognizing the number of people. Nevertheless, the generated descriptions are more aligned with the initially manually annotated sentence structure, so they obtain higher scores in the evaluation metrics.







Input	YOLOv5	OpenCV	ClipCap	Show & Tell
			Person is a fashion actor	A man in a white shirt and jeans is standing in front of a brick wall
			Person and actor are photographed for the wrap	A group of people are standing outside of a building

Figure 1: Visual content labeling using computer vision models.

Although each model has its strengths and weaknesses, the evaluation scores based on the manually annotated sentence structure explained that Show & Tell had the highest scores for the whole dataset (with an average BLEU score of 0.5363, an average METEOR score of 0.2893, and an average ROUGE score of 0.5775), which indicates its suitability for understanding the visual UGC generated by influencers. Therefore, the learned visual variables will be used in the following analysis of consumer engagement.

## Engagement Rate and Data Description

Consumer engagement on Instagram is commonly measured using the number of likes (*#Like*) and the number of comments (*#Comment*). Table 1 shows the descriptive statistics. Considering the huge variance in the number of influencers' followers (*#follower*), the engagement rates for influencer content are calculated for the prediction analysis (Syrdal et al., 2023):

- $L\text{-ratio} = \#Like / \#follower$
- $C\text{-ratio} = \#Comment / \#follower$
- $LC\text{-ratio} = (\#Like + \#Comment) / \#follower$

Table 1: Descriptive statistics on engagement & engagement rate.

	MIN	MAX	MEAN	SD
<i>#Like</i>	0	10,002,079	912,832	2,357,808
<i>#Comment</i>	1	2,520,969	24,809	195,618
<i>#follower</i>	6,620	83,800,000	10,889,190	22,048,114
<i>L-Ratio</i>	0	0.532	0.059	0.076
<i>C-Ratio</i>	4.86-E5	0.536	0.061	0.081
<i>influencerType</i>	42 virtual (24.9%), 127 human (75.1%)			
<b>Notes.</b> Obs.: 169 UGC posts including image and text, covering 6 categories: Apparel (92), Cosmetics (17), E-commerce (2), Food (23), Hotels (16), and Watches (19).				

Table 2 lists all the 21-D variables that will be used in the following engagement analysis, which include 14-D textual variables, 5-D visual variables, and 2-D control variables. *#brandFollower* was included to control the possible impact coming from the popularity of the product or brand, and *influencerType* was also involved to moderate the possible impact of different types of influencers.

Table 2: Variable description.

NOTATION	CONTEXT INFO
<b>Text Variables</b>	
<i>brandNameAppeared</i>	Whether contains the product brand name, Yes(1) or No (0)
<i>productCategoryAppeared</i>	Whether contains the product category, Yes(1) or No(0)
<i>lengthOfThePost</i>	The length of the post
<i>personalPronouns</i>	The personal pronouns used in the post writing
<i>i</i>	First-person singular, such as I, me, and mine
<i>we</i>	First-person plural, such as we, us, and our
<i>you</i>	Second-person, such as you and your
<i>shehe</i>	Third-person singular, such as she, her, he, and his
<i>they</i>	Third-person plural, such as they, their, and them
<i>affective</i>	Refers to vocabulary related to emotions and tone of speech
<i>social</i>	Related to daily interpersonal interactions, including social behavior, communication, relationships, and various social references
<i>cognitive</i>	Represents the category of vocabulary related to mental processes, such as understanding, memory, and problem-solving
<i>perceptual</i>	Represents a category that includes vocabulary related to actions, space, and sensory perception
<i>physical</i>	Represents vocabulary related to physiology and bodily sensations
<b>Image Variables</b>	
<i>#people</i>	The number of people in the image
<i>woman</i>	Whether woman is in the image, Yes(1) or No(0)
<i>man</i>	Whether man is in the image, Yes(1) or No(0)
<i>face</i>	Whether the human face is shown in the image, Yes(1) or No(0)
<i>objects</i>	Whether the sponsor's product appeared in the image, Yes(1) or No(0)
<b>Control Variables</b>	
<i>brandFollower</i>	The number of Instagram followers of the brand
<i>influencerType</i>	The type of the influencer, virtual (1) or human (0)
<b>Note.</b> The linguistic values for <i>personalPronouns</i> , <i>affective</i> , <i>social</i> , <i>cognitive</i> , <i>perceptual</i> , and <i>physical</i> are generated using LIWC. A larger value indicates a higher usage frequency or more emphasis on the corresponding dimension.	

## RESULTS

Instagram users are exposed to both textual and visual UGC when they open an influencer's post. From the UGC perspective, image content may be easier to attract users' attention because of its position (above the text or on the left of the page) and size

(it usually occupies more space compared to text content). From the users' perspective, it is common knowledge that "Like" is an easier interactive activity compared to giving a "Comment". Therefore, to answer the proposed research questions, we conducted regression models on the three engagement rates, respectively. For each one, we compared the performances of human annotation and a computer vision model (i.e., Show & Tell) in engagement prediction.

### LC-ratio

Table 3 gives the regression results. In general, human annotation and computer vision learned similar insights from the impact of textual and visual content on *LC-ratio* engagement, although humans perform slightly better than computer vision in explaining the data (i.e.,  $R^2$  value: M1 = 0.330 vs. = 0.301; M1a = 0.341 vs. M2a = 0.312).

In terms of basic textual variables, adding the brand name to the textual content can significantly boost consumer engagement, while adding the product category is not that important. A long post could negatively affect consumer engagement significantly, which is similar to the findings in Syrdal et al.'s study (2023). For linguistic features, we conducted two models by considering the general *personalPronouns* level and the detailed pronoun level, respectively. Both show a significantly negative impact of *personal pronouns* on engagement. Interesting findings are located in *cognitive* and *perceptual* processes. *Cognitive* processes give rise to implicit aspects of thinking, such as causation, insight, and inclusiveness or exclusiveness. Under the influencer UGC context, the significantly positive impact of *cognitive* ( $p$ -value < 0.05) reflects that including an explanation of why the product is attractive, e.g., advantages, value, etc., could engage consumers' activity. The *perceptual* processes, on the other hand, express human senses, including auditory, visual, and tactile senses. It shows a significantly negative impact on consumer engagement for all four models ( $p$ -value < 0.05), which means mentioning a lot of personal perceptual feelings would be detrimental to engagement.

The finding on *perceptual* factors in the textual content somehow matched the impact of the visual content. The regression results on visual variables show that none of them is significant.

About the two control variables, *#brandFollower* shows different impacts by using human annotation and computer vision. The higher number of brand followers can boost consumer engagement significantly in M1 and M1a ( $p$ -value < 0.01) while performing negatively in M2 and M2a, although the impact is not significant.

Table 3: Modeling results of LC-ratio for human annotation and Show&Tell

VARIABLES	TEXT + HUMAN ANNOTATION		TEXT + SHOW&TELL	
	M1	M1a	M2	M2a
<i>Constant</i>	1.217	0.342	2.505	2.365
<b>Textual Variables</b>				
<i>brandNameAppeared</i>	0.238*	0.199 <sup>o</sup>	0.293*	0.250*
<i>productCategoryAppeared</i>	-0.098	-0.051	-0.141 <sup>o</sup>	-0.089
<i>postLength</i>	-0.255**	-0.230*	-0.215*	-0.203*
<i>personalPronouns</i>	-0.288*		-0.326**	
<i>i</i>		-0.206*		-0.236**
<i>we</i>		-0.133		-0.146
<i>you</i>		-0.060		-0.103
<i>shehe</i>		-0.106		-0.124 <sup>o</sup>
<i>they</i>		-0.088		-0.102
<i>affective</i>	0.018	0.028	-0.081	-0.057
<i>Social</i>	0.051	-0.061	0.085	-0.025
<i>cognitive</i>	0.185*	0.202*	0.179*	0.194*
<i>perceptual</i>	-0.250**	-0.212*	-0.206*	-0.169*
<i>physical</i>	-0.057	-0.072	-0.030	-0.048
<b>Visual Variables</b>				
<i>#people</i>	-0.088	-0.071	0.035	0.077
<i>woman</i>	0.266	0.256	0.016	0.021
<i>man</i>	0.269	0.257	-0.005	-0.024
<i>face</i>	-0.131	-0.128		
<i>objects</i>	-0.003	-0.008	-0.086	-0.098
<b>Control Variables</b>				
<i>#brandFollower</i>	0.218**	0.239**	-0.041	-0.017
<i>influencerType</i>	-0.061	-0.016	-0.128	-0.121
<i>R<sup>2</sup> value</i>	0.330	0.341	0.301	0.312
<b>Notes.</b> <sup>o</sup> $p < 0.1$ , * $p < 0.05$ , ** $p < 0.01$ , *** $p < 0.001$				

### L-ratio and C-ratio

We further conducted four models to understand *L-ratio* and *C-ratio* using text + human annotations and text + Show&Tell separately. In general, computer vision beats humans in predicting *L-ratio* (e.g.,  $R^2$  value: M5 = 0.286 vs. M3 = 0.126), while humans outperform in understanding *C-ratio* compared to computer vision (e.g.,  $R^2$  value: M4 = 0.215 vs. M6 = 0.194).

Studying the modeling results of using text + human annotation, visual features present a significant impact on boosting “Like” engagement, especially when people appear in the image (e.g., the influencer, with a  $p$ -value <0.05 for males and a  $p$ -value < 0.01 for females). However, showing the whole face is not a positive factor for the used data. On the other hand, for *C-ratio*, both textual and visual variables contribute to the engagement to some extent. When a user leaves comments, he or she may take time to read through the text for more information beyond a mere glance at the image. We can see that *brandNameAppeared* and *cognitive* processes are significantly positive, which is the same as their impact on the *LC-ratio*. However, the expression of strong emotion could bring a negative impact because the coefficient of *affective* processes is negative ( $p$ -value < 0.01).

Different from using text + human annotation, the findings of the four models using text + Show&Tell are mainly contributed by textual factors. For example, involving more *cognitive* processes and less personal perceptual feeling could boost the *L-ratio* and *C-ratio*. The silence on the visual side could be caused by poor image annotation of computer vision models compared to human beings.

Table 4: Modeling results of L-ratio and C-ratio for human annotation and Show&Tell

VARIABLES	TEXT + HUMAN ANNOTATION				TEXT + SHOW&TELL			
	L-RATIO		C-RATIO		L-RATIO		C-RATIO	
	M3	M3a	M4	M4a	M5	M5a	M6	M6a
<i>Constant</i>	-9656.87	-16460.40	0.071	0.184	2.488	2.402	0.094	0.048
<b>Textual Variables</b>								
<i>brandNameAppeared</i>	-0.082	-0.161	0.213*	0.239*	0.240*	0.194°	0.297**	0.293**
<i>productCategoryAppeared</i>	0.091	0.127	0.070	0.075	-0.145	-0.094	-0.020	0.003
<i>postLength</i>	-0.005	0.059	-0.095	-0.134	-0.192*	-0.172°	-0.143	-0.174°
<i>personalPronouns</i>	0.008		-0.150		-0.318**		-0.140	
<i>i</i>		-0.075		-0.054		-0.235**		-0.084
<i>we</i>		-0.015		-0.108		-0.125		-0.129
<i>you</i>		0.224		-0.158		-0.073		-0.156
<i>shehe</i>		0.029		-0.087		-0.111		-0.086
<i>they</i>		0.006		-0.065		-0.092		-0.065
<i>affective</i>	-0.173°	-0.187°	-0.256**	-0.247**	-0.080	-0.054	-0.050	-0.054
<i>social</i>	-0.074	-0.241	0.045	0.107	0.079	-0.059	0.049	0.127
<i>cognitive</i>	-0.084	-0.093	0.301**	0.326***	0.076	0.085	0.468***	0.493***
<i>perceptual</i>	0.131	0.174°	-0.005	-0.009	-0.195*	-0.156°	-0.100	-0.091
<i>physical</i>	0.072	0.052	0.035	0.044	-0.046	-0.065	0.039	0.042
<b>Visual Variables</b>								
<i>#people</i>	-0.199	-0.189	-0.173	-0.167	0.046	0.086	-0.038	-0.019
<i>woman</i>	0.577**	0.615**	0.350	0.325	-0.013	-0.009	0.126	0.133
<i>man</i>	0.441*	0.441*	0.153	0.154	-0.053	-0.074	0.191	0.197
<i>face</i>	-0.157°	-0.140	0.005	-0.002				
<i>objects</i>	-0.015	-0.020	-0.223**	-0.227**	-0.078	-0.095	-0.048	-0.037
<b>Control Variables</b>								
<i>#brandFollower</i>	-0.069°	-0.045	-0.183*	-0.193*	-0.042	-0.016	-0.009	-0.010
<i>influencerType</i>	0.089	0.152	-0.011	-0.029	-0.136°	-0.131	-0.026	-0.016
<i>R<sup>2</sup> value</i>	0.126	0.150	0.215	0.220	0.286	0.295	0.194	0.202
<b>Notes.</b> ° $p < 0.1$ , * $p < 0.05$ , ** $p < 0.01$ , *** $p < 0.001$								

### CONCLUSION

In this study, we explored NLP and CV models for understanding influencer UGC posts and further evaluated the impact of UGC on consumer engagement. The findings provide suggestions for more effective influencer marketing strategies to boost brand awareness. Notably, although visual plus textual content is a common combo to promote products or services, the visual content is effective for generating "Likes," while a combination of visual and relevant textual content can increase "Comments." This insight can guide influencers and brands in understanding their followers and adapting UGC creation. While automatic annotation didn't surpass human labeling, it performed similarly. With the growth of UGC and virtual influencers, this study sheds light on artificial intelligence techniques to aid influencers and sponsors in enhancing brand recognition.

Our work is still in the early stages. We plan to implement a completed study further in the next step. First, our dataset is limited, which may cause conclusion bias. We will collect more data and apply a finer-grained investigation to different categories and



brands of products. Second, consider the impact of the interaction of textual and visual features, for example, the interaction impact of the cognitive process featured in the product category or the writing pronouns and gender of the influencer. Third, improve the performance of CV models to gain a better understanding of visual content. Influencers can tell a story and transmit social significance by including various objects in a shot and arranging them in a specific way. An image of a person surrounded by books, for instance, can suggest that someone enjoys reading or is well-informed. However, the hidden higher-level meanings of the image, e.g., the symbolic meaning of the image and contextual relationships between people, objects, and backgrounds, are all lacking in investigation. We will try to explore the abilities of other CV models, including but not limited to generative AI.

## REFERENCES

- Aw, E. C. X., & Chuah, S. H. W. (2021). "Stop the unattainable ideal for an ordinary me!" fostering parasocial relationships with social media influencers: The role of self-discrepancy. *Journal of Business Research*, 132, 146-157. <http://dx.doi.org/10.1016/j.jbusres.2021.04.025>
- Campbell, C., & Farrell, J. R. (2020). More than meets the eye: The functional components underlying influencer marketing. *Business horizons*, 63(4), 469-479. <http://dx.doi.org/10.1016/j.bushor.2020.03.003>
- Fan, F., Chan, K., Wang, Y., Li, Y., & Prieler, M. (2023). How influencers' social media posts have an influence on audience engagement among young consumers. *Young Consumers*, 24(4), 427-444.
- Farivar, S., Wang, F., & Turel, O. (2022). Followers' problematic engagement with influencers on social media: An attachment theory perspective. *Computers in Human Behavior*, 133, 107288. <http://dx.doi.org/10.1016/j.chb.2022.107288>
- Grand Viewer Research (2021). Retrieved from <https://www.grandviewresearch.com/industry-analysis/influencer-marketing-platform-market> (Last accessed June 12th, 2023).
- Haenlein, M., Anadol, E., Farnsworth, T., Hugo, H., Hunichen, J., & Welte, D. (2020). Navigating the New Era of Influencer Marketing: How to be Successful on Instagram, TikTok, & Co. *California management review*, 63(1), 5-25. <http://dx.doi.org/10.1177/0008125620958166>
- Hung, Y. C., & Guan, C. (2020). Winning box office with the right movie synopsis. *European Journal of Marketing*, 54(3), 594-614. <http://dx.doi.org/10.1108/EJM-01-2019-0096>
- Jaakonmäki, R., Müller, O., & Vom Brocke, J. (2017, January). The impact of content, context, and creator on user engagement in social media marketing. In *Proceedings of the Annual Hawaii International Conference on System Sciences* (Vol. 50, pp. 1152-1160). IEEE Computer Society Press. <http://dx.doi.org/10.24251/HICSS.2017.136>
- Janssen, L., Schouten, A. P., & Croes, E. A. (2022). Influencer advertising on Instagram: product-influencer fit and number of followers affect advertising outcomes and influencer evaluations via credibility and identification. *International journal of advertising*, 41(1), 101-127. <http://dx.doi.org/10.1080/02650487.2021.1994205>
- Jun, S., & Yi, J. (2020). What makes followers loyal? The role of influencer interactivity in building influencer brand equity. *Journal of Product & Brand Management*, 29(6), 803-814. <http://dx.doi.org/10.1108/JPBM-02-2019-2280>
- Kwon, J., Chan, K. W., Gu, W., & Septianto, F. (2022). The role of cool versus warm colors in B2B versus B2C firm-generated content for boosting positive eWOM. *Industrial Marketing Management*, 104, 212-225. <http://dx.doi.org/10.1016/j.indmarman.2022.03.011>
- Mokady, R., Hertz, A., & Bermano, A. H. (2021). Clipcap: Clip prefix for image captioning. *arXiv preprint arXiv:2111.09734*.
- Nanne, A. J., Antheunis, M. L., Van Der Lee, C. G., Postma, E. O., Wubben, S., & Van Noort, G. (2020). The use of computer vision to analyze brand-related user generated image content. *Journal of Interactive Marketing*, 50(1), 156-167. <http://dx.doi.org/10.1016/j.intmar.2019.09.003>
- Pennebaker, J. W., Francis, M. E., & Booth, R. J. (2001). Linguistic inquiry and word count: LIWC 2001. *Mahway: Lawrence Erlbaum Associates*, 71(2001), 2001.
- Philp, M., Jacobson, J., & Pancer, E. (2022). Predicting social media engagement with computer vision: An examination of food marketing on Instagram. *Journal of Business Research*, 149, 736-747. <http://dx.doi.org/10.1016/j.jbusres.2022.05.078>
- Syrdal, H. A., Myers, S., Sen, S., Woodroof, P. J., & McDowell, W. C. (2023). Influencer marketing and the growth of affiliates: The effects of language features on engagement behavior. *Journal of Business Research*, 163, 113875.
- Vedantam, R., Lawrence Zitnick, C., & Parikh, D. (2015). Cider: Consensus-based image description evaluation. In *Proceedings of the IEEE conference on computer vision and pattern recognition* (pp. 4566-4575). <http://dx.doi.org/10.1109/CVPR.2015.7299087>
- Vinyals, O., Toshev, A., Bengio, S., & Erhan, D. (2015). Show and tell: A neural image caption generator. In *Proceedings of the IEEE conference on computer vision and pattern recognition* (pp. 3156-3164). <http://dx.doi.org/10.1109/CVPR.2015.7298935>

## User Persistence in Solving Self-Service Technology Problems

Alireza Nili <sup>1,\*</sup>  
Mary Tate <sup>2</sup>  
David Johnstone <sup>3</sup>

\*Corresponding author

<sup>1</sup> Senior Lecturer, Queensland University of Technology, Brisbane, Australia, a.nili@qut.edu.au

<sup>2</sup> Associate Professor, Victoria University of Wellington, Wellington, New Zealand, mary.tate@vuw.ac.nz

<sup>3</sup> Senior Lecturer, Victoria University of Wellington, Wellington, New Zealand, david.johnstone@vuw.ac.nz

### ABSTRACT

Self-service technologies (SSTs) are increasingly becoming a primary channel of service delivery. The move to self-service is sometimes accompanied by a sharp reduction in the availability of assistance from help desk staff. Therefore, user persistence in solving SST problems is important when the problems occur. Organizations need a deep understanding of user persistence with SST problem solving to provide appropriate resources (e.g., self-help resources and user community platforms) for users. In this paper, we identify the factors that contribute to user persistence in: (1) using a specific method of solving SST problems; and (2) solving an SST problem overall.

*Keywords:* User persistence, self-service technology (SST), problem solving.

### INTRODUCTION

Many public and private sector organizations are migrating traditional services to digital self-service channels, and actively encouraging self-service. Reasons for this include expected cost-savings, and a perceived preference for self-service by many users. For example, the Australian Office of the Auditor General estimated the cost of an average government web transaction at \$0.40c, or about 6% of the next most expensive channel, a phone transaction at \$6.60, while a face-to-face transaction is estimated to cost \$16.90 (Delliotte, 2023). Studies have suggested that 49% of Gen Z customers and 41% of Millennials prefer SSTs (Reed, 2022). From the user perspective, advantages of self-service include convenience and accessibility of the service, time and cost saving, and avoiding the necessity of dealing with service personnel (Dao & Theotokis, 2021; Le *et al.*, 2022).

However, as SSTs become more embedded in all aspects of everyday life, problems increasingly occur for users in different contexts (Keating & Aslan, 2023). The move to self-service is sometimes accompanied by a sharp reduction in the availability of 'human' support (e.g., call-center or help desk assistance). Consequently, service users are increasingly left to their own devices to solve self-service problems when they occur (Keating & Aslan, 2023; Nili *et al.*, 2019). Similar expectations of cost savings motivate organizations to consider their internal operations, where face-to-face services such as expense management, leave booking, and resource booking are increasingly replaced with digital self-service solutions for employees. While many organizations do provide 'help desk' and IT support, they are frequently seeking ways to minimize support costs for internal users, who may not have the option of seeking an alternative service to help them with their work (Dao & Theotokis, 2021; Keating & Aslan, 2023; Le *et al.*, 2022).

Users who experience SST problems will demonstrate varying levels of persistence and may adopt a range of methods to resolve their problems when they occur. Organizations will need to find ways to encourage user persistence and help them resolve SST problems, including self-help information, automated assistance (e.g., chatbots), nurturing user communities, and providing human assistance. Otherwise, there is a risk of both external customers switching to alternative service providers, and internal users experiencing frustration and loss of productivity. Service support is a true test of how much a company values customers and is more important than ever (McKinsey & Company, 2023).

It is important to understand the nature of user persistence with SST problem-solving. By identifying the factors that contribute to user persistence, organizations can better manage their support for SSTs. For internal users, these insights will assist with managing internal support costs, and likely result in more productive and happier users. For external customers, organizations can also manage support costs, while increasing customer satisfaction. Accordingly, we characterize the research problem as a need to identify the factors that contribute to user persistence with SST problem solving.

### Framing the Problem

*SST problem* is any gap between user perceptions and expectations with the SST which motivates the user to take corrective action (Dao & Theotokis, 2021; Le *et al.*, 2022; Nili *et al.*, 2019). *Problem-solving* is a process consisting of several steps of identifying and implementing a satisfactory solution for a problem (Chang *et al.*, 2004). A *satisfactory solution* is a solution perceived to be 'satisficing' or 'acceptable', without necessarily being optimal (Nili *et al.*, 2019). Nili *et al.* (2019) developed a process theory for user-based SST problem-solving, establishing that users employ any of three different methods to solve their

SST problems: (1) *self-recovery*: where the user only employs his or her own efforts (using, for example, online instructions and digital troubleshooting guides); (2) *community recovery*: where the user asks for help from other users (e.g., a colleague, friend, or online user community); and (3) *joint-recovery*: where the user interacts with user support staff on a collaborative basis.

SST problem solving can be conceptualized as a process involving a series of decision points, each based on the question: should I continue (i.e., persist) searching for a satisfactory solution, or should I give up? Thus, the process continues until either a satisfactory solution is found or the user gives up (Nili *et al.*, 2019; Zhu *et al.*, 2013). These decision points may occur at any point in the process. However, a user may employ more than one approach in order to solve the SST problem, which identifies another type of decision point, based on the question: should I continue using this method to solve the problem, or should I give up using this method? Figure 1 illustrates the user's overall process of SST problem solving, how that process can be partitioned into a sequence of method-based processes, and the decision points the user will employ at different stages (A, B, or C). Note in this example the user fails to find a satisfactory solution before giving up.

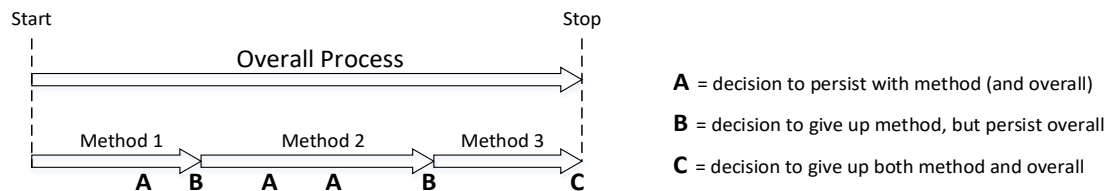

Figure 1: Process model of user SST problem solving.

While previous work has focused on what users do to solve a SST problem (the process view) (Nili *et al.*, 2019), this paper is concerned with what motivates those actions (factors that contribute to persistence with solving the SST problem). This paper and the previous work should be seen as complementary, and together provide a more comprehensive picture of the SST problem solving phenomena. Our research questions are:

*RQ1: What are the factors that contribute to user persistence in solving a SST problem using a specific method?*

*RQ2: What are the factors that contribute to user persistence in solving a SST problem overall?*

In recent years, many businesses have invested heavily in advanced AI-based systems and chatbots to make service support available 24/7 and to reduce the cost of support. Many organizations have also started to deploy the systems (e.g., IBM Watson and ChatGPT) in a part of their daily operations. However, currently, even the most advanced AI systems and chatbots do not have access to all relevant data (e.g., data stored in user profile, service profiles, and service rules) and cannot understand the personal context, service context, and situational context, which are highly important for understanding a user's unique and complex service enquiry and providing personalized responses (Barros *et al.*, 2021; Nili *et al.*, 2020). We believe that assistance in the form of self-help resources such as text-based instructions and video tutorials, as well as assistance from other users (e.g., online community of SST users) and customer service staff are still highly needed for user persistence. Therefore, in this study, we do not focus on any specific method or any specific type of support system.

In the rest of this paper, we first position the concept of user persistence within the motivation theory literature. Next, we explain how we conducted our data collection and analysis. Finally, we provide a discussion of the implications of this study for theory and practice, limitations, suggestions for further research, and a conclusion.

### PERSISTENCE WITHIN THE SST PROBLEM SOLVING CONTEXT

In broad terms, persistence can be understood as a person's perseverance and continuance in a course of action toward a goal despite obstacles (Weiner, 1970). Obstacles may include the person's lack of knowledge or the lack of available resources to achieve a task. Persistence is a concept developed in the psychology literature as a construct reflective of motivation. Kanfer (1990) and Kanfer *et al.* (2017) note that while motivation is not directly observable, it is frequently described in work settings by what a person does (*direction* of behavior), how hard a person works (*intensity* of effort), and how long a person works (*persistence*). She states that direction, intensity, and persistence are the three dependent variables used as motivational outcomes in research. Furthermore, "unlike direction and intensity, persistence criteria capture a pattern of motivational consequences that emerge *only* over time," and that persistence is about "when to shift direction and [intensity]... [and thus it will] encompass elements of direction and intensity, as well as 'executive' motivational processes that maintain task activity levels." (Kanfer, 1990, p.79). Kanfer notes, citing the work of Atkinson and Birch (1970) "that the essential task for motivational researchers is to understand what causes *changes* in the direction of behavior over time (e.g., a shift from working on one task to another)" (p.80). In the context of our study, the task at hand is the SST problem to be solved, not the original task the user was engaged in when the problem occurred.

Therefore, persistence in this context can be characterized in terms of the user's two types of decision points: whether or not to give up with a problem solving method, and whether or not to give up seeking a solution overall. Giving up with a problem solving method, in order to try an alternative method, or giving up overall, each represent a change in the direction of behavior after a period of time. Using these characterizations, we define *method persistence* as a user's decision to continue to use the

same method of SST problem solving in order to achieve a satisfactory solution. We define *overall persistence* as a user's decision to continue to use any combination of methods of SST problem solving in order to achieve a satisfactory solution.

### AN OVERVIEW OF RELEVANT THEORIES AND LITERATURE

We identified several theories which include constructs that are relevant to the topic of our research study. Examples of these theories include: Vroom's Expectancy Theory (1964) (which argues that an individual will evaluate each action from a range of options according to their perception of both the value of the outcome for that action and the likelihood of achieving that outcome); Anderson's theory of Rational Analysis of Problem Solving (1990) (which explains the important roles of an individual's perceptions of cost, probability, and gain/value of solving a problem); The Theory of Reasoned Action (Fishbein & Ajzen, 1975) and its later elaboration, the Theory of Planned Behavior (Ajzen, 1991) (which generally cover the roles of an individual's attitude towards a behavior, the individual's perception of control on that behavior, social norms/pressure from people who are important to the individual, and intention to perform the behavior); Coping Theory (which explains individuals' cognitive and behavioral responses to manage psychological stress) (Lazarus & Folkman, 1984); Self-Determination Theory (Deci & Ryan, 1985) (which focuses on people's basic psychological needs, including autonomy, competence, and relatedness, that are important for their growth and success); Computer Self-Efficacy (Compeau & Higgins, 1995) (which refers to individuals' judgment of their capabilities to use computers in diverse situations); and Weiner's Attribution Theory (Weiner, 1974) (which explains different ways individuals attribute the cause of an effect such as a problem).

While each of these theories includes constructs that are generally relevant to our research phenomenon, none of the theories can help us with answering our research questions and therefore cannot help with identifying an extensive set of persistence factors. For example, Computer Self-Efficacy and Attribution Theory include concepts that are relevant to our work, but they are too specific. On the other hand, the main constructs of the Theory of Reasoned Action and the Theory of Planned Behavior (attitude and behavioral intention) are too broad for our purposes. Moreover, these theories and other theories above (e.g., Expectancy Theory and Theory of Rational Analysis of Problem Solving) are grand theories that cover a wide range of phenomena without providing specific insight for our study. We also note that while Rational Analysis of Problem Solving seems to be the most relevant theory to our work, our findings will show that non-rational factors (e.g., emotions, which can result in a non-rational analysis of a problem) can also contribute to our research phenomenon.

There are also several recent studies which have used one or a small set of the above theories to investigate the notion of SST problem solving from the user's perspective. For example, using the self-determination theory, Chiu and Nguyen (2022) studied customers' perception of their own competence, autonomy, and relatedness (sense of connectedness and belonging), centered on self-recovery of SSTs. Le *et al.* (2022) examined the role of perceived control and risk, and Zhu *et al.* (2013) used the expectancy and attribution theories to investigate customers' responses including self-recovery effort and recovery strategy. Moreover, there are several other studies of SST problem recovery from the user perspective. For example, Yi and Kim (2017) focused on the role of social influence and users' motives for helping each other, and Nili *et al.* (2019) conducted an analysis of problem-solving methods and the overall process of solving SST problems from the user perspective. Dao and Theotokis (2021) investigated the roles of recovery initiation and locus of responsibility (similar to the concept of external attribution of problem), and Keating and Aslan (2023) explain the importance of psychological need support for users with regards to SST recovery. Overall, while there has been an increasing number of studies on SST problem recovery in the past decade, we did not identify any study that: (a) is directly relevant to our research phenomenon (individuals' persistence in solving their SST problems) and (b) provides an extensive set of factors that contribute to user persistence with each method and to overall process of solving SST problems. Our research study fills this important gap.

### RESEARCH METHODS

We obtained ethics approval from the Human Ethics Committee of our university, and then conducted focus groups and semi-structured individual interviews to collect empirical data. We did not use experimental, cross-sectional survey, and observational methods, as the problem solving in our context extends over time (e.g., several days) and limits the insights that the methods can provide. Similarly, data mining methods were not used, as a large part of the overall problem-solving process is not captured by data logs and other similar sources. We explain how we conducted our data collection and analysis.

#### Data Collection Through Focus Groups

First, we conducted focus groups with users of SSTs, inviting them to describe their experiences with persisting with SST problems. Data was collected using the Critical Incident Technique (CIT) (Flanagan, 1954). With this method, the researcher asks participants to recall incidents related to the topic of the research. Previous research suggests that the incidents recalled are important and representative. CIT was suitable for this study, as it helped us to concentrate in detail on specific instances of SST problem-solving using a technique associated with high recall. The overall process of persisting with SST problems may be spread over a considerable period of time. The technique allows us to gather relevant data about the factors that contribute to user persistence with various methods of problem solving that SST users use. We used the CIT technique with three focus groups. The social and interactive nature of focus groups encourages participants to recall their experiences of significant events of SST problems and provides the opportunity for group discussion (Nili *et al.*, 2017) and elaboration of the factors that they believe contribute to persistence when attempting to solve their SST problems.

We needed a context through which we can increase the chance of obtaining as much insights about user persistence as possible. We selected user participants from the students, teaching staff and administrators at a large New Zealand university. The users had some degree of choice over whether to persist or give up, and yet where they were not likely to switch quickly to another provider, as this would have made it difficult to gather in-depth data on persistence. The SSTs included mandatory SSTs (e.g., SSTs for submitting online applications or register for an event) and optional SSTs (e.g., self-checkout systems at libraries). Online self-help information, help-desk support, and user forums existed for many (but not all) services.

The focus groups were advertised throughout the university via notice boards and snowball sampling. Participants were diverse in age, gender, IT expertise, area of study, and role in the university. The first focus group comprised seven teaching staff, with positions ranking from tutor to professor. The second focus group comprised seven students, and the third focus group consisted of ten participants, including six students, two school administrators and two teaching staff. Across the three focus groups, approximately half of the participants were male, and the rest were female. Approximately 60% of the participants were 18-29 years old, 15% were 30-39 years old, 15% were 40-49 years old, 2% were 50-59 years old, and 8% were 60-69 years old. Based on CIT, participants were asked to: (1) recall a SST problem that occurred during the six months prior to the focus group, and how they approached solving it; (2) explain what contribute to their persistence; and (3) engage in a group discussion to elaborate on their points. We video recorded each focus group and transcribed the recordings. Overall, we identified and discussed 52 events of user persistence with solving perceived SST problems, 41 of which relate to distinct SST problems.

### Data Collection Through Individual Interviews

We also collected data from a different set of participants through individual interviews. We used the same data collection context and invited the users to participate in the study through the same channels of communication we had used for the focus groups. Through our emails and information sheet the participants were asked to take note and send (via email) a description of a SST problem that occurred during the two weeks since agreeing to participate. Participants were notified that the interviews would be based on the problems reported. Also, they were informed that at least one instance of a SST problem was the minimum requirement and the two-week period may be extended if no SST problem had occurred.

Overall, 30 participants from a diverse range of backgrounds (e.g., in terms of age, gender, ethnicity and expertise) agreed to participate and attended the interview sessions. Approximately, 27% of the participants were teaching staff, 17% were administration staff, and 56% were students. Among them, about 73% of the participants were male and 27% were female. Approximately 53% of the participants were 18-29 years old, 23% were 30-40 years old, 17% were 41-50 years old, and 7% were 60-69 years old. During the individual interviews, we asked the participants to describe the problem briefly, and then discuss: (1) why they believe it is a problem; (2) why they persisted in solving it; (3) whether they believe that their persistence was important in solving the problem; (4) what things helped them or had a negative effect on their persistence; and (5) whether they have any further comment about factors that contribute to their persistence. Each user was also asked probing questions, dependent on the response to each question. All interviews were audio recorded and fully transcribed. We identified 60 instances of SST problems and user persistence, 51 of which relate to distinct SST problems.

### Data Analysis

We read the transcripts of the focus groups and individual interviews several times. We categorized the most frequent types of SST problems based on the types of participants who experienced the problems. We then imported the transcripts into NVivo for inductive coding. We highlighted and coded data 'chunks' (i.e., units of meaning) such as words, sentences, or paragraphs (Miles *et al.*, 2014, Nili *et al.*, 2017). Each code represented a potentially relevant persistence factor. We were expecting that our iterative process of coding may result in outcomes such as relabeling and merging some of the codes with similar meaning. While the coding of data was fully inductive and grounded in data (we were not constrained by any existing study in the literature), we benefited from our literature review (presented in the previous section) in terms of naming/labeling the codes we had identified in our data and ensuring that we have not missed any important insight. The codes (persistence factors) we identified from the data were then sorted into broad themes based on the similarities in their concepts and nature. Each theme was further revisited for the possibility of being divided into sub-themes. The process required us to revisit and, where necessary, modify the results of the previous analysis efforts and needed several rearrangements and refinements of the themes, i.e., constant comparison (Miles *et al.*, 2014; Nili *et al.*, 2017).

In addition to coding for persistence factors, we also identified methods of SST problem solving from the user perspective, and then used note-taking and diagrams (memoing) to keep track of and refine our ideas, helping us to identify the relationships between the persistence factors and relevant methods and with the overall process of persistence. We held frequent meetings within the research team, and carried out 'member checking' by providing the participants with an interim summary of the results. We present the results for the methods of problem solving first, as these inform aspects of our understanding of the results for each set of factors.

## RESULTS

The most frequent SST problems reported by the teaching staff were related to obtaining and sharing files via the learning management system as well as other temporary problems that related to accessing features of communication tools, particularly email and online teamwork sites, after an upgrade was made to the systems. The most frequent SST problems that students were experiencing were about retrieving course materials from the learning management system and obtaining data from library

applications, mostly due to network connectivity issues when trying to use mobile devices and sometimes due to users' unintentional mistakes. Finally, the SST problems that the administration staff experienced were often related to problems with storing and retrieving data from systems such as workforce management tools, research administration database, and online booking systems, mostly due to limited data storage issues, limited access to the systems, or user's own mistakes. In the rest of this section, we present the major findings including the methods participants were using to solve SST problems, factors that contribute to user persistence with each method, and factors that contribute to the overall process of solving SST problems.

**Methods of Solving SST Problems**

From all focus groups and individual interviews, it became clear that in the event of a perceived SST problem, a user often employs more than one method to solve the problem. We identified three methods of solving SST problems from the user perspective: (1) *self-recovery method*: the user performs problem recovery through their own efforts and may use troubleshooting features (e.g., guides received from a chatbot) and any other self-help information provided by the organization, such as online instructions and video tutorials; (2) *community-recovery method*: the user asks for help from other users such as a friend or colleague in an offline environment, such as an office, or via an online community of users; and (3) *joint-recovery method*: both user and organizational support staff participate in solving the problem and try to solve it jointly/collaboratively. The participants' comments below respectively provide examples of: how users solved their own SST problems through the self-recovery method; through community-recovery method; and the joint-recovery method:

*"I did it (solved the problem) all by myself. I just used the how-to (self-help) information on their website..."*

*"I used a discussion forum. I was sure there are many users who have experienced that problem or know a lot about it".*

*"It is not simply a matter of saying, OK I am giving my problem to support service and then I just fold my arms and forget... You are the one who wants a solution. ... In your case (the participant points to another participant) for example, you handed it back and forth more than once before you were satisfied with the solution".*

All SST users started solving their SST problems through the self-recovery method. Interestingly, there were no exceptions to this pattern. However, some of them demonstrated a low level of persistence with using the method (e.g., just restarting or rebooting the SST) and some others persisted for a longer time and used various self-help information that they had access to. We also realized that where the participants used two methods of SST problem solving, in the majority of cases (almost 80% of the cases) the sequence of using the methods was: self-recovery and then community-recovery. Where all three methods were used, in the majority of cases the sequence of using the methods was: self-recovery, community-recovery, and joint-recovery. While the majority of our participants followed the same sequence of using the three methods, they also reported that they sometimes needed to use a previous method if need arose (e.g., when during the joint-recovery method they discovered a new potential solution that required going back and use the community-recovery method). With regards to the choice of using technological resources for solving SST problems, users used a range of resources such as online video instructions, text-based self-help information, platforms that support online community of users, and chatbots. Advanced artificial intelligence technologies such as ChatGPT did not exist at the time of our data collection or they were not popular tools. Only 10% of the users used chatbots or similar tools to receive information for solving their SST problems. The low percentage was also due to the technologies' lack of capability to provide detailed responses to users' specific questions.

**Factors Contributing to User Persistence**

In this next section, we present the persistence factors that we identified from the focus groups and individual interviews. Table 1 presents these factors grouped in the forms of themes and sub-themes. As we developed the codes, we could see that some of the factors were linked to persistence with one or more of the problem-solving methods (Table 2) and some of the factors contribute to persistence with the entire process of solving SST problems (Figure 2).

Table 1: Factors contributing to persistence in solving SST problems.

Themes and sub-themes	Persistence factors	Definition	Participants' comments
Outcome/Goal-Related Factors	Probability of a Satisfactory Outcome through a Method	User's perceived probability of solving a SST problem through a specific method of solving SST problems	"I was pretty hopeful about solving the problem. I somehow knew it can be solved if I ask another user for help."
	Overall Probability of a Satisfactory Outcome	User's perceived probability of solving a SST problem through all possible methods of solving SST problems	"The probability [that I can solve it] was definitely important. I never thought that I will never have the network"
	Importance of Satisfactory Outcome	How important it is for a user to achieve a satisfactory SST problem resolution	"I needed it... Any solution that works is enough for me." "...The importance of the output - what I want to achieve..."



				because eventually the output is the most important thing.”
Cost-Related Factors	Expected Method Cost	Expected Time	Expected amount of time for solving a SST problem through a specific method	“I don't waste time. I phone someone.”
		Expected Effort	Expected amount of effort for solving a SST problem through a specific method	“I was expecting I need to make much effort to figure out what's wrong with it...”
		Expected Negative Emotions (anxiety and frustration)	The amount of negative emotions a user expects to experience with regards to solving a SST problem through a specific method	“It was becoming really frustrating... That's why I didn't want to continue”
	Expected Overall Cost	Overall Expected Time	Expected overall amount of time required for solving a SST problem through all possible methods	“... , but, overall, it was taking too long and I needed the system to upload my document.”
		Overall Expected Effort	Expected overall amount of effort required for solving a SST problem through all possible methods	“I may be just investing more effort and some cost... You may continue to make the investment.”
		Overall Expected Negative Emotions (anxiety and frustration)	The overall amount of negative emotions a user expects to experience with regards to solving a SST problem through all possible methods	“When you are more frustrated ..., you are less likely to be thinking thoroughly or willing to spend time...”
Personal Factors	SST Problem Solving Self-Efficacy	Individuals' judgment of their capability in executing actions of resolving SST problems	“I believe I can handle these [SST] problems by myself”	
	Prior Knowledge of Solving SST Problems	Prior knowledge of solving SST problems, helping a user with solving a SST problem	“It depends on how much we know... so based on our previous experiences we decide what our course of action would be.”	
	Internal Attribution of SST problem	Tendency to attribute the cause of a SST problem to one's own actions	“I usually think it (the reason) is me. I usually just think I am ignorant. There should be a button somewhere that I have not seen...”	
	External Attribution of SST problem	Tendency to attribute cause of a SST problem to external factors (e.g., bad SST design or business's ignorance)	“The [reason for the] problem is not me... I just contacted them (service staff) to fix it...”	
	Subjective Norm	User's perception that most people who are important to them think that the user should or should not solve the SST problem	“...their opinion was important; I [felt] I have to solve it.”	
	Perceived Control over Solving the SST Problem	Perception of control on one's own activities and behavior of solving a SST problem	“... because for my problem I cannot have the admin right, sometimes I found the answer, but I could not apply it.”	
System Quality/ Characteristics Factors	SST Interactivity	User's perception of how well a system responds to commands and how easily it enables arrangement of the amount, sequence, and style of presented information	“... how do I get that on that university computer now? It was straightforward. It looked like, okay, transfer to external device and stuff like that. I just followed all the things [it asked me to do], like talk me through, basically.”	
	SST Ease of Use	A user's perception that using a SST would be free of effort	“It was really difficult to find the option you want... Even if you find it, it is not easy enough.”	



	Usefulness of SST	A user's perception that using the SST enhances job or activity performance	"It (the SST) was a useful thing... otherwise, why to persist?"
Situational Factors	Trustworthiness of Staff Joint-Recovery Performance	The overall trustworthiness (covering reliability, helpfulness, and responsiveness) of the support that service support staff provide for SST users	"I had them on the phone and we tried to solve it. They couldn't work out what it was. ...the quality of their work was not good at all."
	Quality of Responses from Users in the Community	The overall quality (covering reliability, usefulness, and presentation quality) of the response that SST users in an online or offline community provide for a user who experienced a SST problem	"... A lot of people probably already know many tricks about it and they could contribute." "The only thing I could do was to join the discussion forum...I have found it quite amazing that these discussion forums really solved the problem."
Quality of Self-Help Information (provided by the business in the form of do-it-yourself guidance, video tutorials, and responses from chatbots deployed by the business)	Usefulness of Self-Help Information	The extent to which the self-help information is complete, current, accurate, easy to understand and relevant to solving a specific SST problem	"The information was useful. Really thorough, up to date, comprehensible, correct, and most importantly relevant to the problem I experienced."
	Obtainability of Self-Help Information	The extent to which the available self-help information is fast and easy to obtain	"It was easy for me to obtain the self-help info. I mean so fast and easy to access."
	Presentation of Self-Help Information	The extent to which the self-help information is concise, consistent, and contextualized for solving SST problems	"So much information, even though you try to be specific and use specific keywords...". "For one problem, you have got different information...".
	Reliability of Self-Help Information	The extent to which the self-help information is original, believable and reputable	"A user says I did this, which had this result, and another user may say I did this and it magically worked." "If it (the information) is original, I continue...". "If the information I find online was provided by a reputable source... I continue..."

We realized that the complexity/difficulty of solving a SST problem is captured in the expected cost factors (expected amount of time, negative emotions, and effort required to solve the problem). We also note that 'quality of self-help information', 'quality of responses from users in the community', and 'trustworthiness of staff joint-recovery performance' can be studied at a lower (more detailed) level. However, given the extensiveness of our findings, we decided not to analyze these aspects in more detail.

### Factors Contributing to User Persistence with Each Method and to the Overall Process of Solving SST Problems

Analysis of the data revealed that some of the factors only contribute to user persistence with a specific method of solving SST problems, some factors contribute to persistence with each of the three methods, and some factors contribute to persistence with the overall process of solving the problem. Importance of a satisfactory outcome is the only factor that contributes to both persistence with a specific method and to the overall process (collective methods). Importance of a satisfactory outcome, probability of a satisfactory outcome through a method, and factors within the theme of expected method cost are the ones that contribute to persistence with each of the three methods. Personal factors, system quality factors, and quality of self-help information only contribute to user persistence with self-recovery method.

For example, with regards to SST interactivity, which only contributes to the self-recovery method, a participant mentioned *"the moment I tried to restart the computer, I was prompted through a message to save what I've done... I moved on [through the guidance I received] to solve it."* The Quality of responses from community of users only contribute to user persistence with the community-recovery method. For example, a participant stated *"... I visited a discussion forum and started talking with someone... He started giving me recommendations to do this and do that... We were talking at a level of very dirty tricks that you can do on computers... like I was hopeful about it. [That's why] I spent one full day working on it, with his ping pong, do this, do that."*

Similarly, trustworthiness of staff joint-recovery performance contributes to persistence with the joint-recovery method. For example, a participant stated “when I called them, and after a couple of calls from students, [the support staff] said that they just realized that the problem [with the library’s database search feature] has happened. They were not expecting this problem.... We were not sure about any positive outcome... I gave up after a while.”. Table 2 presents the factors that contribute to user persistence with each method of solving SST problems.

Table 2: Factors that contribute to persistence with each method of solving SST problems.

Method	Factors contributing to user persistence with the method	
Self-recovery Method	Personal factors	(a) SST problem solving self-efficacy, (b) prior knowledge of solving SST problems, (c) internal attribution of SST problem, (d) external attribution of SST problem, (e) subjective norm, and (f) perceived control over solving the SST problem
	System quality factors	(a) SST interactivity, (b) SST ease of use, and (c) SST usefulness
	Quality of self-help information	(a) obtainability, (b) reliability, (c) usefulness, and (d) presentation
	Probability of a satisfactory outcome through the method	
	Importance of a satisfactory outcome	
	Expected method cost	(a) Expected time, (b) expected effort, and (c) expected negative emotions (anxiety and frustration)
Community-recovery Method	Quality of responses from users in the community	(a) Reliability, (b) usefulness, and (c) presentation
	Probability of a satisfactory outcome through the method	
	Importance of a satisfactory outcome	
	Expected method cost	(a) Expected time, (b) expected effort, and (c) expected negative emotions (anxiety and frustration)
Joint-recovery Method	Trustworthiness of staff joint-recovery performance	(a) Reliability, (b) helpfulness, and (c) responsiveness
	Probability of a satisfactory outcome through the method	
	Importance of a satisfactory outcome	
	Expected method cost	(a) Expected time, (b) expected effort, and (c) expected negative emotions (anxiety and frustration)

Overall probability of a satisfactory outcome, importance of a satisfactory outcome, and factors related to the expected overall cost (overall expected effort, overall expected time, and overall expected negative feelings) are the factors that contribute to persistence with the overall process of SST problem solving. As we discuss in the next section, the three major factors in the figure clearly confirm our positioning of the user persistence phenomena within the group of motivation and cognitive choice research studies and in the specific real-world technology context of SST problem-solving.

Figure 2 summarizes the findings of this research study. It illustrates the factors that contribute to user persistence with each method and to the overall process of solving SST problems. It also illustrates the sequence of the methods users use and the iterative nature of solving SST problems, where (as we explained before) a user may need to go back and forth between the methods to solve the problem.

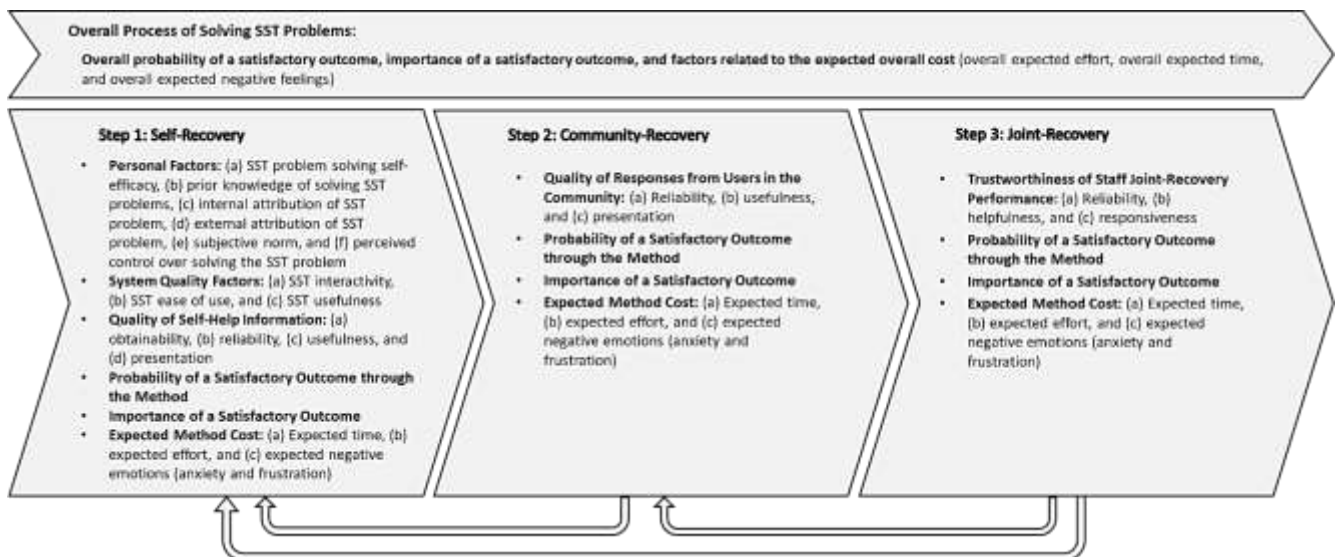

Figure 2: Factors that contribute to user persistence with each method and to the overall process of solving SST problems.

## DISCUSSION

We reviewed relevant theories in the family of motivation, expectancy, and problem-solving theories, and explained that they are grand theories that cover a wide range of phenomena without providing specific insight into our research phenomenon and our research questions. Given the uniqueness of our research topic and the research questions, we conducted an inductive study, through which we conceptualized users' persistence in solving their SST problems and identified an extensive set of persistence factors that contribute to each method of solving SST problems and to the overall process of solving the problems. Our study of persistence factors in SST problem-solving provides a detailed perspective that situates our study in a specific research phenomenon and real-world technology context. Moreover, in contrast to many of the existing theories and studies, particularly Rational Analysis of Problem Solving, which focus on rational inputs, we identified both rational and non-rational factors (e.g., 'emotions' within the expected cost theme) that contribute to our research phenomenon.

E-service and SST recovery literature did not contribute fresh insights to our study. We realized that the studies draw on grand theories or they focus on organizational strategies, not the user's process of problem-solving and/or contributing persistence factors. Also, many of the studies focus on considerations such as compensation and complaint handling, which are not relevant to the specific aim and scope of our study.

For organizations designing support systems for SST recovery, understanding the factors that lead to persistence with different *methods* will inform support strategies. There is little value in an organization wishing to reduce their service costs by concentrating on optimizing their help desk performance, but not investing in interactivity of their help system, or in building users' skills and self-efficacy. We also explained why we did not focus on any automated support (e.g., AI-based chatbots) and aimed to look at the research phenomenon broadly and cover all methods that users employ to persist in solving their own SST problems. Help and problem-solving systems should be developed with the same attention to quality as the main service.

It is not realistic to expect every SST user to possess an in-depth technical knowledge and skills of SST problem recovery. For example, many millennials have a level of dependence on technologies that is higher than their technology skill-levels. However, collectively, this knowledge is usually available within the wider community of SST users. The popularity of social media platforms has led to an explosion of user forums on topics ranging from travel (e.g., Tripadvisor.com) and search for property (Nili & Barros, 2022) to health (e.g., WebMD.com) and widely used technology tools such as salesforce.com (<https://success.salesforce.com/>). Investment in building and supporting a quality user community is essential to building user persistence with problem solving.

With regards to the limitations of our study, we note that the exclusive reliance on the user's self-report and retrospective data might generate a risk of hindsight bias. We tried to minimize this risk and the risk of recall bias by employing the CIT to gather data about the most memorable SST problem events and how they were solved. We also note that we did not use experimental, cross-sectional survey, and observational methods, because the problem-solving process in our context extends over time (sometimes several days) and limits the insights that the methods can provide for us. Also, data mining methods were not used, as a large part of the overall problem-solving process is not captured by data logs and other similar sources. Future researchers may still be interested in deploying these methods to complement our research findings.

We conducted the study in an intra-organizational context where many of the SSTs used by our respondents did not have any competitors. This enabled us to gather in-depth data about all possible persistence factors. Future research may focus on data collection in a competitive context, compare their findings with the findings of our research study and complement our study.

Moreover, we did not aim to measure the degree of user persistence or study the degree to which persistence leads to success or effectiveness in solving a SST problem. This could be an interesting area for future researchers to build on our study and complement our research findings.

## CONCLUSION

The convergence of rapid digital innovations, pressure to reduce costs, and a preference for digital and self-service channels for accessing an increasing number of services has led to the situation where there are a large number of users who are increasingly expected to be self-reliant when using SSTs. Supporting and retaining these customers is a major issue for organizations. In an intra-organizational context, SST problems mean lost productivity and decreased motivation. In a contestable context, SST problems cause lowered perceptions of service quality and may result in defection. The assumption that a new generation of tech-savvy users can easily get on with resolving their own problems with limited support may not be realistic. The ability to effectively understand, support, and encourage users to persist in solving their SST problems has not previously been identified as a core business competency for managing support costs, and increasing customer satisfaction. We hope our study will stimulate greater focus on this essential component of customer service in SST contexts.

## REFERENCES

- Ajzen, I. (1991). The theory of planned behavior. *Organizational Behavior and Human Decision Processes*, 50(2), 179-211. <https://doi.org/10.1080/08870446.2011.613995>
- Anderson, J. R. (1990). *The adaptive character of thought*. Hillsdale, NJ: Erlbaum.
- Atkinson, J. W., & Birch, D. (1970). On the dynamics of action. *Nederlands Tijdschrift voor de Psychologie en haar Grensgebieden*, 25(2), 83-94.
- Barros, A., Sindhgatta, R., & Nili, A. (2021). Scaling up chatbots for corporate service delivery systems. *Communications of the ACM*, 64(8), 88-97. <https://doi.org/10.1145/3446912>
- Chang, E. C., D'Zurilla, T. J., & Sanna, L. J. (2004). *Social problem solving: Theory, research, and training*. American Psychological Association. <https://doi.org/10.1037/10805-000>
- Chiu, Y. T. H., & Nguyen, D. M. (2022). Service failure and self-recovery in tech-based services: Self-determination theory perspective. *The Service Industries Journal*, 42(13-14), 1075-1100. <https://doi.org/10.1080/02642069.2022.2104257>
- Compeau, D. R., & Higgins, C. A. (1995). Computer self-efficacy: Development of a measure and initial test. *MIS Quarterly*, 19(2), 189-211. <https://doi.org/10.2307/249688>
- Dao, H. M., & Theotokis, A. (2021). Self-service technology recovery: The effect of recovery initiation and locus of responsibility. *Journal of Interactive Marketing*, 54(1), 25-39. <https://doi.org/10.1016/j.intmar.2020.09.001>
- Deci, E. L., & Ryan, R. M. (1985). Conceptualizations of intrinsic motivation and self-determination. In *Intrinsic Motivation and Self-Determination in Human Behavior, Perspectives in Social Psychology*. Springer, Boston, MA. [https://doi.org/10.1007/978-1-4899-2271-7\\_2](https://doi.org/10.1007/978-1-4899-2271-7_2)
- Delliotte: Digital government transformation. Retrieved from <https://www2.deloitte.com/content/dam/Deloitte/au/Documents/Economics/deloitte-au-economics-digital-government-transformation-230715.pdf> (accessed 10 February 2023).
- Fishbein, M., & Ajzen, I. (1975). *Belief, attitude, intention, and behaviors: An introduction to theory and research*. Boston, MA: Adison.
- Flanagan, J. C. (1954). The critical incident technique. *Psychological Bulletin*, 51(4), 327-358. <https://doi.org/10.1037/h0061470>
- Kanfer, R. (1990). Motivation theory and industrial and organizational psychology. *Handbook of industrial and organizational psychology*, 1(2), 75-130.
- Kanfer, R., Frese, M., & Johnson, R. E. (2017). Motivation related to work: A century of progress. *Journal of Applied Psychology*, 102(3), 338-355. <https://doi.org/10.1037/apl0000133>
- Keating, B. W., & Aslan, M. (2023). Self-service technology recovery: The importance of psychological need support. *Journal of Service Management*, 34(4), 725-749. [DOI 10.1108/JOSM-12-2021-0464](DOI 10.1108/JOSM-12-2021-0464)
- Lazarus, R. S., & Folkman, S. (1984). *Stress, appraisal, and coping*. Springer Publishing Company, Inc., New York, NY.
- Le, N. T., Rao Hill, S., & Troshani, I. (2022). Perceived control and perceived risk in self-service technology recovery. *Journal of Computer Information Systems*, 62(1), 164-173. <https://doi.org/10.1080/08874417.2020.1756533>
- Lien, C. H., Hsu, M. K., Shang, J. Z., & Wang, S. W. (2021). Self-service technology adoption by air passengers: A case study of fast air travel services in Taiwan. *The Service Industries Journal*, 41(9-10), 671-695. <https://doi.org/10.1080/02642069.2019.1569634>
- McKinsey & Company: The state of customer care in 2022. Retrieved from <https://www.mckinsey.com/capabilities/operations/our-insights/the-state-of-customer-care-in-2022> (accessed 12 February 2023).
- Miles, M. B., Huberman, A. M., & Saldaña, J. (2014). *Qualitative data analysis: A methods sourcebook*. Thousand Oaks, CA: Sage.
- Nili, A., Tate, M., & Johnstone, D. (2019). The process of solving problems with self-service technologies: A study from the user's perspective. *Electronic Commerce Research*, 19, 373-407. <https://doi.org/10.1007/s10660-018-9304-0>
- Nili, A., Barros, A., Johnstone, D., & Tate, M. (2020). Technological enablers for preventing service failure with e-commerce websites. In *Proceedings of the 27th European Conference on Information Systems*, Stockholm & Uppsala, Sweden.
- Nili, A., & Barros, A. (2022). Salient design features that your social media platform needs: The case of online communities of interest. *First Monday*, 27(3). <https://doi.org/10.5210/fm.v27i3.11831>

- Nili, A., Tate, M., Johnstone, D. (2017). A framework and approach for analysis of focus group data in information systems research. *Communications of the Association for Information Systems*, 40(1). <https://doi.org/10.17705/1CAIS.04001>
- Reed, M. (2022). Gen Z and your customer self-service. Retrieved from <https://www.creativevirtual.com/gen-z-and-your-customer-self-service/#:~:text=%2C%2049%25%20of%20Gen%20Z,generational%20shift%20towards%20self%2Dservice> (accessed 15 April 2023).
- Vroom, V. H. (1964). *Work and motivation*. New York, NY: Wiley & Sons.
- Weiner, B. (1974). *Achievement motivation and attribution theory*. General Learning Press.
- Weiner, H. (1970). Human behavioral persistence. *The Psychological Record*, 20, 445-456. <https://doi.org/10.1007/BF03393965>
- Yi, Y., & Kim, S. Y. (2017). The role of other customers during self-service technology failure. *Service Business*, 11, 695-715. <https://doi.org/10.1007/s11628-016-0325-2>
- Zhu, Z., Nakata, C., Sivakumar, K., & Grewal, D. (2013). Fix it or leave it? Customer recovery from self-service technology failures. *Journal of Retailing*, 89(1), 15-29. <https://doi.org/10.1016/j.jretai.2012.10.004>

## Utilizing a Gamified Mobile APP to Promote Post-COVID Nurses in Managing Their Self-Health

Li Jung Lu <sup>1</sup>  
Shao Huan Hsu <sup>2,\*</sup>

\*Corresponding author

<sup>1</sup> PhD, National Chung Cheng University, Chiayi, Taiwan, y0058@yuanhosp.com.tw

<sup>2</sup> Master, National Chung Cheng University, Chiayi, Taiwan, gg372100@gmail.com

### ABSTRACT

The COVID-19 pandemic has profoundly impacted the physical and mental health of frontline healthcare workers worldwide. Nurses in particular face heightened risks of adverse health outcomes including infection, mortality, mental health issues, and burnout due to their high exposure to COVID-19 patients. Although nurses often have high health awareness due to their medical background, research shows that most nurses have not adopted effective self-health management practices and fail to meet recommended physical activity guidelines. Mobile health (mHealth) apps represent a promising channel for providing external interventions to assist nurses in managing their health. They offer advantages such as real-time self-monitoring, personalized recommendations, and increased accessibility over traditional tools). However, current commercially available mHealth apps lack rigorous theoretical grounding and have shown mixed results in improving health behaviors and outcomes. This highlights the need for purpose-designed, evidence-based mHealth apps tailored to nurses' specific needs and preferences. Gamification techniques, which employ video game elements in non-game contexts, have grown increasingly popular in mHealth apps to drive user engagement and motivation. However, research on their efficacy for physical activity promotion remains limited and inconclusive. Thoughtful integration of gamification with behavior change theories may enhance outcomes, but this requires careful empirical testing. This study aims to develop and evaluate a gamified mobile health app to promote physical activity and improve health outcomes among nurses at a large hospital in Taiwan. It incorporates insights from user-centered design and goal-setting theory to create a tailored, theory-based gamified app.

Following a design science approach, initial semi-structured interviews were conducted with key stakeholders and end users at the hospital including nursing directors, health promotion staff, and 15 nurses to identify user requirements, preferences, and pain points. This provided critical inputs for the app design. A total of 296 nurses working in diverse departments and representing a range of age groups and educational backgrounds were then recruited as study participants for evaluating the developed app. The prototyping methodology was utilized to iteratively design, develop, test and refine the health app through an agile, user-centered process. App features were personalized to end user feedback at each stage. The final app incorporates core functionalities including: step counter synchronized with smartphones, body data tracking (e.g. weight, blood pressure), personalized avatar, virtual island for exploration, leaderboard, quests and challenges, goal setting and tracking, timed events and reminders, achievement badges, and social engagement features. Gamification elements such as points, levels, rankings, rewards and social interaction were seamlessly integrated to drive motivation and user engagement. The app also integrates goal-setting theory by allowing users to set personalized health goals and providing feedback on their progress. Quantitative and qualitative user testing and feedback indicate that the app was enjoyable, satisfactory, and effective in assisting users achieve their health goals. Participants reported increased exercise adherence, health awareness, and sense of accomplishment. The combination of gamification and goal-setting proved successful in promoting healthy behaviors. However, reliance on self-reported data and lack of long-term follow-up assessments are limitations. Potential biases include social desirability bias and limitations in recall accuracy.

This study demonstrates the significant potential of gamified mobile health apps to engage nurses in self-health management by meeting their preferences and needs. The participatory, user-centered design process resulted in an app tailored to users' needs and preferences, contributing to strong uptake and satisfaction. Results contribute to the growing body of literature on gamification for health promotion. Insights gained can inform future efforts to support nurses' wellbeing during global health crises. Wider implementation across healthcare institutions is recommended, as nurses worldwide face these challenges. However, rigorous longitudinal studies on the app's effectiveness and impacts on health outcomes are still warranted. Future work should also include more objective measures of health behaviors and effects.

*Keywords:* Gamification, exercise prescription, ESG

### INTRODUCTION

At the end of 2019, the world was severely impacted by the outbreak of Covid-19, and to this day, the pandemic remains a serious issue. Healthcare systems in various countries have been greatly affected, and frontline healthcare workers have made sacrifices and contributions to their nations. The physical and mental health of these healthcare workers is crucial, as they face a

higher risk of contracting Covid-19 (Leeds, 2021), which in turn increases the risk of physical illnesses, psychological disorders, and adverse health outcomes, including death (David et al., 2021, Saragih et al., 2021, Yifan et al., 2020, Yunitri et al., 2022, Chutiyami et al., 2022), thereby significantly impacting their overall well-being (Cag et al., 2021, Li et al., 2021). The United Nations' "Who Cares Wins" report emphasizes that global businesses should incorporate the Environmental, Social, and Governance (ESG) criteria into their operational standards. The "Social" aspect of this framework includes the need to address and support the physical health of employees within organizations. Therefore, addressing the physical and mental health issues of healthcare workers within hospitals is an urgent priority.

The promotion of healthcare worker's physical and mental well-being can be broadly divided into self-management and external interventions. In terms of self-management, the World Health Organization (WHO), the National Center for Chronic Disease Prevention and Health Promotion (NCCDPHP), and some scholars (Piercy et al., 2018) have suggested that engaging in physical activity for more than 150 minutes per week can help improve physical and mental health. However, healthcare workers often do not meet this guideline (Melnik et al., 2021). Since self-management approaches have proven to be ineffective, external interventions are needed to assist healthcare workers in managing their health.

In recent years, online health management platforms and mobile applications have become important channels for individuals to manage their weight and health status (Yang et al., 2019). Currently, there are many external interventions available to assist healthcare workers. Although these digital platforms make it easier for users to plan exercise and diet programs and effectively change their health-related behaviors, users' weight management outcomes may decrease due to a lack of motivation and interest (Yang et al., 2019, Tortorella et al., 2020). Regarding exercise planning, the American College of Sports Medicine (ACSM) has defined exercise prescription guidelines that should follow the FITT principle, which includes frequency, intensity, time, and type (ACSM's Guidelines for Exercise Testing and Prescription (9th ed.)). However, Burnet et al. (2019) argue that the FITT principle lacks the important element of "fun," and they propose the FITTF principle, which is more comprehensive. Currently, few health management apps on the market adhere to the FITTF principle. If an exercise prescription lacks enjoyment, individuals may struggle to adhere to the goals set by the prescription (Burnet et al., 2019). Therefore, incorporating gamification elements could enhance the important aspect of enjoyment.

In recent years, there has been an increasing trend of health management apps incorporating gamification elements. Initially, gamification was implemented without a unified approach, with only a few scattered game elements added, lacking theoretical support. Although gamification is prevalent in the field of health management, its effectiveness has not been conclusively proven (Yang, & Li, 2021). Xu et al. (2022) analyzed 50 studies on gamified mobile health applications related to physical activity and found that some studies showed an increase in user engagement through gamification, while others yielded different results (Xu et al., 2022). Thus, it is necessary to further explore whether gamification can enhance the effectiveness of health management platforms.

## **RESEARCH PURPOSE & PROBLEM**

### **Research Problem**

The COVID-19 pandemic has profoundly impacted the physical and mental health of frontline healthcare workers. Nurses face heightened risks of adverse health outcomes including infection, mortality, mental health issues, and burnout due to their high exposure to COVID-19 patients. Although nurses often have high health awareness due to their medical background, research shows that most nurses have not adopted effective self-health management practices and fail to meet recommended physical activity guidelines. Mobile health (mHealth) apps represent a promising channel for providing external interventions to assist nurses in managing their health. However, current commercially available mHealth apps lack rigorous theoretical grounding and have shown mixed results in improving health behaviors and outcomes. This highlights the need for purpose-designed, evidence-based mHealth apps tailored to nurses' specific needs and preferences. Gamification techniques have grown increasingly popular in mHealth apps to drive user engagement and motivation, but research on their efficacy remains limited and inconclusive.

### **Research Purpose**

Given these research gaps, this study aims to develop and evaluate a gamified mobile health app to promote physical activity and improve health outcomes among nurses at a large hospital in Taiwan. It incorporates insights from user-centered design and goal-setting theory to create a tailored, theory-based gamified app. The research seeks to provide design insights for gamified mHealth apps that can aid in supporting nurses' health and wellbeing in the post-pandemic era.

## **LITERATURE REVIEW**

### **Mobile Health Applications**

Mobile health applications utilize mobile applications and digital technologies to provide users with healthcare information (Khenarinezhad et al., 2020). With the advancements and widespread adoption of mobile technology, mobile healthcare tools, apps, and interventions can seamlessly integrate into people's daily lives. Compared to traditional medical tools, mobile health apps offer real-time data collection through their immediacy, user-friendliness, and convenience (Atienza, & Patrick, 2011). By minimizing user time costs, they enhance acceptability. Mobile health apps also open up direct communication channels with users, providing features such as real-time reminders and feedback (Nahum-Shani et al., 2018). Due to their effectiveness, they have been widely employed in various applications within the healthcare field.



In addition to the commercially available mobile health applications mentioned earlier, academic research has explored various aspects of mobile health interventions. For example, studies have investigated the use of mobile interventions to address mental health issues among healthcare workers during the COVID-19 pandemic (Fiol-DeRoque et al., 2021) and to promote mental health among university students (Bendtsen et al., 2020).

Research has also focused on using mobile health apps to improve the self-management of chronic conditions such as chronic obstructive pulmonary disease (COPD) (Yang et al., 2018) and chronic low back pain (Selter et al., 2018). Furthermore, studies have examined the use of mobile apps or health technologies to enhance adult dietary quality (Scarry et al., 2022) and provide dietary tracking and recommendations (Semper et al., 2016). There has also been research on weight management, including controlling weight and setting weight loss goals through mobile health interventions (Aguilar-Martínez et al., 2014, Bardus et al., 2015, Bardus et al., 2016, Quelly et al., 2016, Riaz, & Sykes, 2015, Flores Mateo et al., 2015, Schippers et al., 2017, Vlahu-Gjorgievska et al., 2018).

During the COVID-19 pandemic, the usage and reliance on mobile health apps have increased significantly. The advancements in related technologies and expanded network infrastructure have propelled the rapid development of mHealth (Baskar, & Rao, 2022). Khenarinezhad et al. (2020) highlighted the essential role of mobile health apps in self-management, education, and accessing health information for COVID-19 patients, particularly for individuals in close contact with COVID-19 patients (Khenarinezhad et al., 2020).

Therefore, this study aims to develop a mobile health application specifically targeting nurses who frequently come into contact with COVID-19 patients, to assist them in self-management and healthcare practices.

### **Gamification**

Gamification aims to generate a positive "game-like" user experience by incorporating design principles inspired by games into information systems, services, or activities (Hamari et al., 2019, Koivisto, & Hamari, 2019). It utilizes game-like elements to motivate or encourage behaviors in non-game contexts, fostering meaningful engagement while serving both experiential and instrumental purposes (Liu et al., 2017). Common game design elements include points, levels, leaderboards, badges, challenges, and quests (Zichermann, & Cunningham, 2011).

Numerous studies have already demonstrated that gamification can effectively enhance motivation (Groening, & Binnewies, 2019, Denny, 2013), performance (Zichermann, & Cunningham, 2011, Bai et al., 2020, Mollick, & Rothbard, 2014, Witt et al., 2011, ), and persistence (Landers, & Landers, 2014), among other outcomes.

### **METHODS**

Based on the review of existing literature, there appears to be a research gap in developing gamified mobile health applications tailored specifically for nurses in the post-pandemic era. The COVID-19 pandemic has created immense health burdens and risks for frontline healthcare workers like nurses, highlighting an urgent need for targeted digital health interventions to assist them. However, current research lacks in-depth investigation into designing evidence-based gamified apps that address the unique needs and preferences of nurses for managing their health during this challenging time.

To fill this research gap, this study conducts in-depth interviews and consultations with key stakeholders at a case hospital in Taiwan to perform functional and needs analysis. The interviews aim to garner crucial insights directly from nurses as well as health promotion staff regarding the required features and functionalities for a health management app catered to nurses. This allows the identification of user requirements, pain points, and preferences to inform the design of a tailored gamified app.

The functional and needs analysis through stakeholder interviews serves as a critical initial step to ensure the app is user-centered and accepted by the target users. This process facilitates the development of an exercise prescription program within the app that aligns with the needs of nurses, incorporating suitable exercise frequency, intensity, time, type as well as enjoyment elements. Subsequently, the functional analysis aids the design of app features and interfaces that nurses find motivating and engaging. Overall, the in-depth interview process enables the creation of a gamified mobile health application with high relevance to nurses' needs during the post-COVID-19 period and a strong potential for positive health impacts. The user-centered design approach based on interviews establishes a solid foundation for the app development and increases likelihood of adoption.

### **Research Subjects/Participants**

This research study was conducted at Mackay Memorial Hospital located in Hsinchu, Taiwan. Mackay Memorial Hospital was selected as an ideal research site because the hospital administration actively prioritizes and promotes various initiatives to improve employee health and wellbeing. For instance, the hospital implements comprehensive annual health check-ups and ongoing health tracking mechanisms for all employees to monitor their health status. Additionally, the hospital frequently organizes health education seminars and training programs covering topics like chronic disease management, workplace wellness, stress reduction, and healthy lifestyles. These sessions serve to enrich employees' health knowledge and literacy.

Furthermore, the hospital strongly encourages employees across all departments to participate in health promotion activities organized by the administration. Various fitness challenges, health competitions, and wellness campaigns are conducted year-

round to motivate employees to adopt healthier lifestyles. Financial and non-financial incentives like paid leave, prizes, and recognition are also used to increase engagement in these initiatives.

In summary, Mackay Memorial Hospital provides a supportive environment and existing infrastructure to promote staff health and wellbeing. Therefore, the research team determined it was an ideal setting to develop and evaluate a tailored game-based health management mobile application targeting the hospital's nursing staff. With over 2000 nurses working across diverse departments, Mackay Memorial Hospital offered access to a substantial pool of potential participants for this research study. A total of 296 nurses were ultimately recruited to participate in app testing and provide feedback from the perspective of targeted end users. The hospital's heavy investment in employee health promotion and participants' rich insights strengthen the practical implications of study findings to guide future nursing health initiatives.

### **System Development Methodology**

The research team contemplated suitable system development methodologies for creating the gamified mobile health application. Traditional system development life cycle (SDLC) approaches like waterfall involve long, sequential stages including extensive planning, requirements gathering, design, implementation, testing, and deployment. While rigorous, SDLC methods require high development costs and time investments. Significant resources are spent upfront before testing the system's capabilities. SDLC approaches also risk inaccurately capturing or poorly prioritizing user requirements. Once deployed, fixes or enhancements incur heavy documentation and process overhead.

In contrast, prototyping offers notable advantages as an iterative, user-centered development methodology. It allows creating an initial prototype based on known basic requirements, soliciting user feedback, and rapidly refining the system through multiple cycles of prototyping, evaluation, and enhancement. This agile approach facilitates developing a satisfactory system meeting user needs within a short timeframe and budget. Prototyping enables direct validation of requirements throughout the process rather than assuming complete upfront understanding. The research team can flexibly improve features and usability issues based on user testing data after each iteration. Overall, prototyping reduces cost and speeds up development through targeted user involvement and incremental refinements.

Considering these benefits, the research team determined prototyping was the optimal methodology for this gamified health app development project. Prototyping enabled creating a testable version incorporating preliminary features and functionality within a reasonable timeframe and budget. The researchers collected empirical user feedback to validate designs and incrementally enhance the prototype across multiple iterations. This ensured the final app met end user requirements and preferences. The prototyping methodology allowed efficiently developing and validating a gamified mobile system tailored to nurses' needs for health management within the project constraints.

### **System Interview**

To inform the gamified health app design, the research team conducted in-depth interviews with key stakeholders at the hospital. A guided approach was adopted for the interviews. The interviewers prepared an outline and list of focal questions in advance covering topics like user needs, challenges, preferences and desired features. During the interviews, the interviewers flexibly adapted and expanded the questions based on the insights and responses shared by the interviewees. This semi-structured approach allowed comprehensively capturing qualitative insights from stakeholders while keeping the conversations targeted and relevant.

The interviews focused on the Health Promotion Committee members given their pivotal role in employee wellness initiatives. The Health Promotion Committee is responsible for strategic planning and execution of programs that cultivate a culture and environment that enhances employee health. This committee is led by the Vice President and comprises diverse leaders including nursing directors, human resource heads, and health educators. They oversee key programs like:

1. Activities to support mental health and reduce burnout
2. Annual health check-ups and tracking
3. Health literacy education and training
4. Encouraging participation in workplace wellness activities

The stakeholder interviews aimed to deeply understand the stakeholders' perspectives on the required features and functionalities for a tailored gamified app that would effectively engage nurses in managing their health. The interviews provided a platform for stakeholders to share insights based on their expertise in nursing health promotion initiatives and awareness of nurses' needs and preferences.

Detailed notes were compiled during the interviews to document the stakeholders' responses. As summarized in Table 2, the interviews generated a wealth of valuable qualitative data confirming core features like goal-setting, tracking, social engagement, and gamification elements to include in the app. The interviews ensured the app was designed in a targeted manner to address nurses' needs.

Table 2: The interview results.

The session(s).	Time	Number of participants.	Conclusion
1	2 hr	4	Main Objective of the App: The main objective is weight control. Functional Requirements: Step counter, Body data recording, Avatar (virtual representation of the user), Virtual island tour, Leaderboard, Missions, Goal setting
2	2 hr	4	Functional Requirements: Exercise Prescription, Time-limited Events
3	2 hr	4	Functional Requirements: Achievements, Treasure Hunt

### RESULT

From Table 3, it can be observed that there are more female users than male users. Table 4 provides the distribution of educational background among participants across different age groups. Table 5 shows the level of participation among various service units.

Table 3: The number of participants by gender in each age group.

	<20	20~30	30~40	40~50	50~60	>60
Male	0	12	45	37	9	1
Female	0	35	59	67	25	5

Table 4: The educational status of participants in each age group.

	<20	20~30	30~40	40~50	50~60	>60
High school vocational	0	5	13	30	11	3
Specialist	0	13	21	23	5	2
University	0	28	64	19	2	0
Graduate School	0	1	6	32	16	1

Table 5: The educational status of participants in each age group.

	<20	20~30	30~40	40~50	50~60	>60
Nursing department	0	15	30	35	13	3
Administration Department	0	10	36	35	15	3
Medical Technology Department	0	11	32	8	0	0
Physician	0	0	4	26	7	0
Escort	0	11	2	0	0	0

The integration of goal-setting theory is another vital aspect contributing to the success of this gamified mobile health application. Goal-setting theory is an evidence-based framework that postulates setting specific and challenging yet achievable goals, combined with feedback on progress, can effectively motivate behavior change and performance improvements. Therefore, incorporating key goal-setting theory components into the app design enhanced its capability to motivate meaningful health behavior change.

Specifically, the app allows users to actively set their own personalized health and fitness goals tailored to their current level and needs, cultivating a sense of autonomy and self-direction. Users can customize goals like target number of steps, exercise frequency/duration, or weight loss objectives based on their priorities and capabilities. This sense of control and ownership over one's goals is a crucial psychological factor driving sustained motivation according to goal-setting theory principles.

In addition, the app provides various features for users to closely monitor their progress towards their predefined goals. Detailed activity tracking and analytics allow users to tangibly visualize achievements like step counts, running stats, and weight changes over time. This continuous, quantifiable feedback on their advancement towards explicit targets reinforces motivation and self-efficacy. Periodic app notifications and prompts also facilitate goal commitment.

Overall, thoughtfully integrating key constructs from goal-setting theory, like personalized goal prescription and actionable feedback loops, helped optimize the app to motivate nurses to adopt and adhere to regular physical activity habits. The tailored user experience enhanced both intrinsic motivation and self-competence to succeed in managing health goals. This amplified the effects of gamification techniques integrated in the app. The positive results validate the value of combining established behavioral science theories like goal-setting theory with gamification and user-centric design.

### CONCLUSION

The results of this study demonstrate the gamified mobile health app's successful integration of evidence-based gamification techniques and goal-setting theory principles to effectively motivate nurses and facilitate positive health behavior changes. Quantitative user feedback indicates strong perceptions of enjoyment, satisfaction and engagement with the app experience. Participants also reported the app was highly effective in assisting them to achieve their predefined health and fitness goals. Qualitative feedback further highlights users' increased adherence to regular physical activity, heightened health awareness, and an enhanced sense of accomplishment from reaching their targets.

These positive outcomes affirm the value of thoughtfully combining gamification dynamics with established behavioral science theories like goal-setting theory when designing health interventions. This study makes important contributions to the growing body of research on gamification in mobile health. The findings provide practical insights into optimal design strategies, grounded in theory and user-centric design, to develop highly impactful gamified apps that meaningfully engage users.

However, some limitations should be considered when interpreting the results. The assessments of the app's effectiveness currently rely on subjective self-reported measures from users. Self-reports can be influenced by biases including difficulties recalling accurately and providing socially desirable responses. To further validate results, future studies should seek to incorporate more objective quantitative measures of health behaviors such as activity tracking data. Conducting long-term follow-up assessments would also help verify sustained impacts on health outcomes over time.

Overall, despite these limitations, this research makes significant contributions both theoretically and practically. The results strongly demonstrate the potential of thoughtfully designed, theory-driven gamified mobile health apps to promote healthy lifestyles and improve wellbeing, especially among high-risk populations like nurses during global health crises. These insights can inform continued efforts to support frontline healthcare workers' health and engagement worldwide.

### ACKNOWLEDGMENTS

We would like to express our sincere gratitude and appreciation to all those who have contributed to the completion of this research project. We are grateful to the participants who generously shared their time and insights for the interviews and surveys, providing crucial data and perspectives for our study. We also thank the staff and administration of the healthcare institution for their cooperation and assistance in facilitating the data collection process. Lastly, we appreciate the understanding, encouragement, and continuous support from our friends and family members throughout this research journey. Once again, we extend our heartfelt thanks to everyone who contributed to the completion of this study.

### REFERENCES

- ACSM's Guidelines for Exercise Testing and Prescription (9th ed.) 2014. (<https://www.ncbi.nlm.nih.gov/pmc/articles/PMC4139760/>)
- Aguilar-Martínez, A., Solé-Sedeño, J.M., Mancebo-Moreno, G., Medina, F.X., Carreras-Collado, R., & Saigí-Rubió, F. (2014). Use of mobile phones as a tool for weight loss: a systematic review. *J Telemed Telecare*, 20(6), 339–49. <https://doi.org/10.1177/1357633X14537777>
- Atienza, A. A., & Patrick, K. (2011). Mobile health: the killer app for cyberinfrastructure and consumer health. *American journal of preventive medicine*, 40(5), S151-S153. <https://doi.org/10.1016/j.amepre.2011.01.008>
- Bai, S., Hew, K. F., & Huang, B. (2020). Does gamification improve student learning outcome? Evidence from a meta-analysis and synthesis of qualitative data in educational contexts. *Educational Research Review*, 30, 100322. <https://doi.org/10.1016/j.edurev.2020.100322>
- Bardus, M., Smith, J.R., Samaha, L., & Abraham, C. (2015). Mobile phone and web 2.0 technologies for weight management: a systematic scoping review. *J Med Internet Res*, 17(11), e259. <https://doi.org/10.2196/jmir.5129>

- Bardus, M., Smith, J.R., Samaha, L., & Abraham, C. (2016). Mobile and Web 2.0 interventions for weight management: an overview of review evidence and its methodological quality. *Eur J Public Health*, 26(4), 602–10. <https://doi.org/10.1093/eurpub/ckw090>
- Baskar, P., & Rao, S. (2022). Role of mobile health in the situation of COVID-19 pandemics: pros and cons. *Cyber-Physical Systems*, 37-54. Academic Press. <https://doi.org/10.1016/B978-0-12-824557-6.00005-4>
- Bendtsen, M., Müssener, U., Linderoth, C., & Thomas, K. (2020). A mobile health intervention for mental health promotion among university students: randomized controlled trial. *JMIR mHealth and uHealth*, 8(3), e17208. <https://doi.org/10.2196/17208>
- Burnet, K., Kelsch, E., Zieff, G., Moore, J.B., & Stoner, L. (2019). How fitting is F.I.T.T.?: A perspective on a transition from the sole use of frequency, intensity, time, and type in exercise prescription. *Physiology & Behavior*, 199(1), 33-34. <https://doi.org/10.1016/j.physbeh.2018.11.007>
- Cag, Y., Erdem, H., Gormez, A., Ankarali, H., Hargreaves, S., Ferreira-Coimbra, J., Rubulotta, F., Belliato, M., Berger-Estilita, J., Pelosi, P., Blot, S., Lefrant, J.Y., Mardani, M., Darazam, I.A., Cag, Y., Rello, J. (2021). Anxiety among front-line health-care workers supporting patients with COVID-19: A global survey. *Gen Hosp Psychiatry*, 68, 90-96. <https://doi.org/10.1016/j.genhosppsy.2020.12.010>
- Chutiyami, M., Bello, U.M., Salihu, D., Ndwigwa, D., Kolo, M.A., Maharaj R., Naidoo, K., Devar, L., Pratitha, P., & Kannan, P. (2022). COVID-19 pandemic-related mortality, infection, symptoms, complications, comorbidities, and other aspects of physical health among healthcare workers globally: An umbrella review *International Journal of Nursing Studies*, 129, 104211. <https://doi.org/10.1016/j.ijnurstu.2022.104211>
- David, H. M. S. L., Rafael, R. M. R., de Mello Alves, M. G., Breda, K. L., de Araújo Faria, M. G., Neto, M., & da Silva, M. C. N. (2021). Infection and mortality of nursing personnel in Brazil from COVID-19: A cross-sectional study. *International journal of nursing studies*, 124, 104089. <https://doi.org/10.1016/j.ijnurstu.2021.104089>
- Denny, P. (2013). The effect of virtual achievements on student engagement. *Proceedings of the SIGCHI conference on human factors in computing systems*, 763-772. <https://doi.org/10.1145/2470654.2470763>
- Fiol-DeRoque, M. A., Serrano-Ripoll, M. J., Jiménez, R., Zamanillo-Campos, R., Yáñez-Juan, A. M., Bennasar-Veny, M., Leiva, A., Gervilla, E., García-Buades, M.E., García-Toro, M., Alonso-Coello, P., Pastor-Moreno, G., Ruiz-Pérez, I., Sitges, C., García-Campayo, J., Llobera-Cánaves, J., & Ricci-Cabello, I. (2021). A Mobile phone-based intervention to reduce mental health problems in health care workers during the COVID-19 pandemic (PsyCovidApp): randomized controlled trial. *JMIR mHealth and uHealth*, 9(5), e27039. <http://hdl.handle.net/doi:10.2196/27039>
- Flores Mateo, G., Granado-Font, E., Ferré-Grau, C., & Montaña-Carreras, X. (2015). Mobile phone apps to promote weight loss and increase physical activity: a systematic review and meta-analysis. *J Med Internet Res*, 17(11), e253. <https://doi.org/10.2196/jmir.4836>
- Groening, C., & Binnewies, C. (2019). “Achievement unlocked!”-The impact of digital achievements as a gamification element on motivation and performance. *Computers in Human Behavior*, 97, 151-166.
- Hamari, J. G., Ritzer, G., & Rojek, C. (2019). *The Blackwell Encyclopedia of Sociology*. John Wiley & Sons. <https://doi.org/10.1002/9781405165518.wbeos1321>
- Khenarinezhad, S., Ghazanfarisavadkoochi, E., & Shahmoradi, L. (2020). Mobile Health Applications to Support COVID-19 Self-management: Review and Evaluation. *Applied Health Information Technology*, 2(2), 44-56. <https://doi.org/10.2196/20596>
- Koivisto, J., & Hamari, J. (2019). The rise of motivational information systems: A review of gamification research. *International Journal of Information Management*, 45, 191-210. <https://doi.org/10.1016/j.ijinfomgt.2018.10.013>
- Landers, R. N., & Landers, A. K. (2014). An empirical test of the theory of gamified learning: The effect of leaderboards on time-on-task and academic performance. *Simulation & Gaming*, 45(6), 769-785.
- Leeds, C. (2021). COVID 19: Health care workers, risks, protection and transmission. *The Lancet Regional Health–Europe*, 1. <https://doi.org/10.1016/j.lanepe.2020.100022>
- Li, J., Su, Q., Li, X., Peng, Y., & Liu, Y. (2021). COVID-19 negatively impacts on psychological and somatic status in frontline nurses. *Journal of Affective Disorders*, 294, 279-285. <https://doi.org/10.1016/j.jad.2021.07.031>
- Liu, D., Santhanam, R., & Webster, J. (2017). Toward Meaningful Engagement: a framework for design and research of Gamified information systems. *MIS quarterly*, 41(4). <https://doi.org/10.25300/MISQ/2017/41.4.01>
- Melnyk, B. M., Hsieh, A. P., Tan, A., Gawlik, K. S., Hacker, E. D., Ferrell, D., & Badzek, L. (2021). The state of mental health and healthy lifestyle behaviors in nursing, medicine and health sciences faculty and students at Big 10 Universities with implications for action. *Journal of Professional Nursing*, 37(6), 1167-1174. <https://doi.org/10.1016/j.profnurs.2021.10.007>
- Mollick, E. R., & Rothbard, N. (2014). Mandatory fun: Consent, gamification and the impact of games at work. *The Wharton School research paper series*, 54. <https://doi.org/10.2139/ssrn.2277103>
- Nahum-Shani, I., Smith, S. N., Spring, B. J., Collins, L. M., Witkiewitz, K., Tewari, A., & Murphy, S. A. (2018). Just-in-time adaptive interventions (JITAs) in mobile health: key components and design principles for ongoing health behavior support. *Annals of Behavioral Medicine*, 52(6), 446-462. <https://doi.org/10.1007/s12160-016-9830-8>

- Piercy, K. L., Troiano, R. P., Ballard, R. M., Carlson, S. A., Fulton, J. E., Galuska, D. A., & Olson, R. D. (2018). The physical activity guidelines for Americans. *Jama*, *320*(19), 2020-2028. <https://doi.org/10.1001/jama.2018.14854>
- Quelly, S.B., Norris, A.E., & DiPietro, J.L. (2016). Impact of mobile apps to combat obesity in children and adolescents: a systematic literature review. *J Spec Pediatr Nurs*, *21*(1), 5–17. <https://doi.org/10.1111/jspn.12134>
- Riaz, S., & Sykes, C. (2015). Are smartphone health applications effective in modifying obesity and smoking behaviours? A systematic review. *Health Technol*, *5*(2), 73–81. <https://doi.org/10.1007/s12553-015-0104-4>
- Saragih, I. D., Tonapa, S. I., Saragih, I. S., Advani, S., Batubara, S. O., Suarilah, I., & Lin, C. J. (2021). Global prevalence of mental health problems among healthcare workers during the Covid-19 pandemic: a systematic review and meta-analysis. *International journal of nursing studies*, *121*, 104002. <https://doi.org/10.1016/j.ijnurstu.2021.104002>
- Scarry, A., Rice, J., O'Connor, E. M., & Tierney, A. C. (2022). Usage of Mobile Applications or Mobile Health Technology to Improve Diet Quality in Adults. *Nutrients*, *14*(12), 2437. <https://doi.org/10.3390/nu14122437>
- Schippers, M., Adam, P.C., Smolenski, D.J., Wong, H.T., & de Wit, J.B. (2017). A meta-analysis of overall effects of weight loss interventions delivered via mobile phones and effect size differences according to delivery mode, personal contact, and intervention intensity and duration. *Obes Rev*, *18*(4), 450–459. <https://doi.org/10.1111/obr.12492>
- Selter, A., Tsangouri, C., Ali, S. B., Freed, D., Vatchinsky, A., Kizer, J., Sahuguet, A., Vojta, D., Vad, V., Pollak, J.P., & Estrin, D. (2018). An mHealth app for self-management of chronic lower back pain (Limbr): pilot study. *JMIR mHealth and uHealth*, *6*(9), e8256. <https://doi.org/10.2196/mhealth.8256>
- Semper, H. M., Povey, R., & Clark-Carter, D. (2016). A systematic review of the effectiveness of smartphone applications that encourage dietary self-regulatory strategies for weight loss in overweight and obese adults. *Obesity reviews*, *17*(9), 895–906.
- Tortorella, G.L., Fogliatto, F.S., Espôsto, K.F., Vergara, A.M.C., Vassolo, R., Mendoza, D.T., & Narayanamurthy, G. (2020). Effects of contingencies on healthcare 4.0 technologies adoption and barriers in emerging economies. *Technological Forecasting and Social Change*, *156*, 120048. <https://doi.org/10.1016/j.techfore.2020.120048>
- Vlahu-Gjorgievska, E., Mulakaparambil Unnikrishnan, S., & Win, K. T. (2018). mHealth applications: A tool for behaviour change in weight management. *Stud. Health Technol. Inform*, *252*, 158-163. <https://doi.org/10.3233/978-1-61499-890-7-158>
- Witt, M., Scheiner, C. W., & Robra-Bissantz, S. (2011). Gamification of online idea competitions: insights from an explorative case. *GI-Jahrestagung*, *392*. <http://informatik2011.de/519.html>
- Xu, L., Shi, H., Shen, M., Ni, Y., Zhang, X., Pang, Y., & Li, F. (2022). The Effects of mHealth-Based Gamification Interventions on Participation in Physical Activity: Systematic Review. *JMIR mHealth and uHealth*, *10*(2), e27794. <https://doi.org/10.2196/27794>
- Yang, F., Wang, Y., Yang, C., Hu, H., & Xiong, Z. (2018). Mobile health applications in self-management of patients with chronic obstructive pulmonary disease: a systematic review and meta-analysis of their efficacy. *BMC pulmonary medicine*, *18*(1), 1-9. <https://doi.org/10.1186/s12890-018-0671-z>
- Yang, H., & Li, D. (2021). Understanding the dark side of gamification health management: A stress perspective. *Information Processing & Management*, *58*(5), 102649. <https://doi.org/10.1016/j.ipm.2021.102649>
- Yang, H., Du, H.S., Wang & L., Wu, L. (2019). The influence of social support networks on health conditions via user engagement: Gender as a moderator. *Journal of Electronic Commerce Research* *20*(1), 35-54.
- Yifan, T., Ying, L., Chunhong, G., Jing, S., Rong, W., Zhenyu, L., Zejuan, G., & Peihung, L. (2020). Symptom cluster of ICU nurses treating COVID-19 pneumonia patients in Wuhan, China. *International journal of nursing studies*, *121*, 104002. <https://doi.org/10.1016/j.ijnurstu.2020.03.039>
- Yunitri, N., Chu, H., Kang, X. L., Jen, H. J., Pien, L. C., Tsai, H. T., Kamil, A.R., & Chou, K. R. (2022). Global prevalence and associated risk factors of posttraumatic stress disorder during COVID-19 pandemic: A meta-analysis. *International journal of nursing studies*, *126*, 104136. <https://doi.org/10.1016/j.ijnurstu.2021.104136>
- Zichermann, G., & Cunningham, C. (2011). *Gamification by design: Implementing game mechanics in web and mobile apps*. " O'Reilly Media, Inc.", 1449397670.



## **Bridging the Gap between E-Learning and E-Business Education Management in English Teaching — A Case Study of Kaysersberg Education Group in Taiwan**

Hsiu-Chin Wang <sup>1,\*</sup>

\*Corresponding author

<sup>1</sup>HEC Liège Executive Education, Management School- Liège Université, Liège, Belgium, Executive Doctorate in Business Administration EDDB Student, linda.kaysersberg@gmail.com

### **ABSTRACT**

In the rapidly evolving world of education, the intersection of technology and pedagogy presents unprecedented opportunities for enhancing learning and teaching. This conference paper explores the symbiotic relationship between e-learning, e-business education management, and information technology education management in the context of English language education. Conducted within the English language schools of Kaysersberg Education Group in Taiwan, this research investigates the transformative potential of merging these dimensions to enrich English language instruction. The study employs advanced technological tools to bridge the realms of e-learning, e-business education management, and information technology, aiming to optimize English language education for both learners and educators.

The literature review highlights the significance of integrating e-resources into e-learning environments and emphasizes the role of librarians, students, and teachers in updating and refining these resources. It also discusses the challenges faced by distance learners and the importance of effective communication. Furthermore, it delves into the importance of technological familiarity for e-learning students and the impact of e-learning on students' motivation and foundational skills. The review also stresses the multifaceted assessment of teacher quality and the benefits of e-learning tools in classrooms.

The research methodology involves the strategic use of advanced technological tools, including digital cameras, digital video technology, scanners, OCR software, recording software, and internet resources. These tools are employed to create a bridge between e-learning, e-business education management, and information technology, enhancing English instruction within language schools.

The study's findings underscore the need for progressive teaching methodologies that incorporate technology and promote interactive pedagogy. It highlights how the transformation of language acquisition can empower students and eliminate barriers to English language learning. The research advocates for embracing innovative teaching approaches, fueled by technology, and fostering a collaborative learning environment.

This conference paper concludes by emphasizing the potential of merging technology with pedagogy to revolutionize English language education and reshape the future of teaching and learning. By integrating e-learning, e-business education management, and information technology education management, education can become more inclusive, interactive, and learner-centric. This transformative journey holds the promise of elevating confidence, enthusiasm, and engagement among students, catalyzing a generational shift in education dynamics. The paper invites collective efforts to shape an inspiring future of education characterized by collaboration, innovation, and shared growth.

*Keywords:* E-learning, education management, English teaching, English language schools

### **INTRODUCTION**

In today's rapidly evolving world, the confluence of technological advancements and educational paradigms has opened unprecedented avenues for enhancing the process of learning and teaching. This conference paper presents a comprehensive exploration of the symbiotic relationship between e-learning, e-business education management, and information technology education management within the realm of English language education. The research, conducted within the English language schools of Kaysersberg Education Group, endeavors to unravel the transformative potential of merging these dimensions to enrich English language instruction.

My investigation is grounded in a dynamic methodology that harnesses the capabilities of advanced technological tools. These tools include a digital camera for capturing instructional visuals, digital video technology for recording and transcribing



instructional content, scanners for digitizing imagery from print sources, Optical Character Recognition (OCR) software for efficient textual conversion, recording software for audio enhancements, and the expansive reach of the internet to access relevant course materials. By creating a bridge between the realms of e-learning, e-business education management, and information technology, this research aspires to optimize the efficiency and efficacy of English language instruction, thereby benefiting both learners and educators alike.

The pedagogical landscape is evolving, prompted by the relentless march of time, scientific discoveries, and the intelligent application of technology. The metamorphosis catalyzed by Electronicalization and the imminent advent of AI symbolize major transformations in human civilization. As we embark on this journey, the imperative to continually adapt and progress becomes evident. The transition from conventional teaching methods towards a dynamic amalgamation of technology and pedagogy is a testament to our commitment to foster a more interactive and engaging learning theater.

This paper extends beyond the confines of mere pedagogy; it delves into the realm of language acquisition. When a second language ceases to be an alien construct and evolves into an intrinsic form of expression, students' engagement with the language is transformed. This paradigm shift redefines the learning experience, obliterating the barriers of personality traits or environmental context that once hindered students' embrace of English. This realization prompts a call for effective teaching methodologies, united with E-based strategies and the potential of future AI, which are brimming with promise. The outcome: a sweeping generational change, characterized by elevated confidence and enthusiasm in English language education.

As I embark on this transformative journey, this conference paper not only unravels the findings and discussions emerging from our research but also delineates the implications of my discoveries. With this, we strive to create a scholarly discourse that inspires a collective commitment to shape the future of education—where technology harmoniously intertwines with pedagogy, and where learners and educators are empowered to co-create an inspiring and collaborative educational ecosystem.

#### **LITERATURE REVIEW**

The landscape of education is experiencing a profound transformation within the context of the knowledge society. The advent of information technology (IT) in this knowledge-driven era has paved the way for innovative learning scenarios where technology assumes a pivotal role in the sharing and dissemination of knowledge. As emphasized by Ally (2004, p.22), e-learning materializes when students leverage the web to navigate the pedagogical sequence, accomplish learning activities, and attain predefined learning outcomes. To illustrate, an e-learning system facilitates learners' access to formal educational content, yet it often falls short in integrating e-resources that are closely aligned with curricula to augment the educational process and nurture learners' growth. This discrepancy is particularly pronounced in developing nations, where learners have limited exposure to e-resources due to a myriad of technical, cultural, and resource-related challenges (Abuzaid & Singh, 2007). Recently, a consensus has emerged on the significance of incorporating e-resources into the fabric of e-learning environments. While this integration might impose additional burdens on learners and educational institutions, the emergence of contemporary information technology (IT) has the potential to alleviate these challenges substantially.

With regard to the theoretical framework, Cobbah (2004) contends that e-resources offer students a unique opportunity to access, assess, and structure current information from diverse sources within today's knowledge society. Consequently, devising a robust framework for e-resources to bolster e-learning environments stands out as a paramount endeavor, applicable to both traditional and virtual educational settings. For such a framework to thrive, the web-based system must be supported by a continuous inflow of up-to-date resources, constructive feedback loops, and requests for new e-resources from all stakeholders involved. To ensure the currency of e-resources, this study postulates that the web-based system should incorporate three primary actors: librarians, students, and teachers. Their collaborative efforts in updating and refining resources should be meticulously orchestrated and synchronized. This holistic approach transforms e-resources into a catalyst that empowers students, educators, and librarians alike to actively contribute to the advancement of learning and teaching outcomes through an ongoing process of iterative improvement facilitated by sustained collaboration.

In the realm of e-learning, students often possess an awareness of the delivery method employed for their courses but may lack an understanding of the intricacies and technological intricacies that underlie these programs (University of Texas, 2000). The nuances of the educational experience and the extent of faculty and administrative support may elude their realization. Consequently, these learners must adopt a proactive stance toward their education and grasp the commitment and self-motivation necessary for successful distance learning. Existing surveys reveal that students engaged in distance education frequently express dissatisfaction with the level of communication from the institution, particularly in terms of relaying campus policies. Although the responsibility of communicating these policies lies with the school administration, students occasionally misdirect their grievances toward instructors for the dearth of information provided. Additionally, students should be able to identify a designated individual to approach for advice and registration matters, a role that some institutions mandate to be performed on campus, counterintuitively challenging the essence of a "distance" program (University of Texas, 2000).

For e-learning students, unfettered access to library resources remains a pivotal requirement. Advances in technology over the past few years have significantly facilitated this aspect. Academic libraries have made remarkable progress in granting students remote access to information resources through the internet. These libraries extend assistance and guidance in locating information, offer remote access to electronic resources, and even facilitate the delivery of materials that are not accessible electronically (Rosenquist-

Buhler, 1996).

It is imperative not to make assumptions or take for granted that distance learners possess familiarity with the diverse array of technologies employed for delivering course content. Ensuring that easily comprehensible technological information forms a component of all materials dispatched to students is crucial (University of Texas, 2000). Utilizing email as a channel for communication, facilitators can maintain contact with students, ensuring their progress and delivering words of encouragement. Such efforts contribute to fostering a sense of belonging within a well-supported program (Chaudhry, 1999).

English educators, as proficient language learners themselves, should remain attentive and willing to experiment with novel techniques while fostering creativity in English instruction both inside and outside the classroom, as articulated by Maulidar, Gani & Samad (2019). In the context of ESL teaching, it is imperative to possess comprehensive knowledge and a readiness to adapt the curriculum based on the individual capacities of students through e-learning, as illuminated by Hardan (2013). Such an approach cultivates students' self-assurance and linguistic expressiveness, dispelling the apprehension of errors by enabling them to integrate these skills into their daily lives. This pedagogical facet holds substantial importance in education, as effective teaching not only motivates educators but also enhances students' learning experiences and academic achievements (Hamid, Hassan & Ismail, 2012).

Previous research has suggested that the efficacy of e-learning can be gauged by its impact on students' accomplishments, contingent on the influence of educators. However, evaluating the caliber of a teacher involves a multifaceted assessment that encompasses instructional preparation and assurance (Darling-Hammond, 2000), experience and knowledge (Goe, 2007), pedagogical prowess and optimism, in addition to systematic expertise (Waxman et al., 2003). Investigations into the integration of e-learning tools in classrooms underscore the contribution of information and communication technology (ICT) in fostering a conducive and motivating milieu for students, thereby augmenting the quality and quantity of their foundational skills (Pandey & Mishra, 2016). This conclusion is reinforced by Zorío's (2018) examination of Kahoot, a widely utilized online quiz game that serves as an effective online resource for educators.

In essence, a significant proportion of students actively participated in lessons employing e-learning devices like computers and mobile phones, thus enhancing their enthusiasm for English learning. Licorish et al. (2017) concur, contending that sustained motivation facilitated by e-learning empowers students to engage autonomously in the learning process. Sharma (2018) contends that e-learning has undeniably bolstered students' foundational competencies by augmenting their involvement in classroom activities. Findings from the study revealed that students assimilated diverse strategies during lessons, encompassing memory, cognitive, compensatory, metacognitive, affective, and social approaches, all facilitated by e-learning. Echoing this sentiment, Harris & Rutledge (2007) posit that the predictors of educator quality and effectiveness encompass cognitive aptitude, personal attributes, and educational background in the context of e-learning. The authors emphasize the importance of educators' commitment and enthusiasm toward instruction to foster improvements in students' academic performance. Amid the 21st-century education landscape, educational institutions, ranging from primary to secondary levels, are redesigning pedagogical methods and paradigms to enhance teaching efficacy, thereby elevating English language instructors' motivation, a sentiment validated by Sikand & Kauts (2016). In this contemporary era, educators are actively embracing novel teaching techniques and adapting their approaches to create a harmonious and constructive learning environment through the medium of e-learning (Tehseen & Hadi, 2015).

## MYTHODOLOGY

The research methodology encompasses the strategic utilization of a range of advanced technological tools:

A digital camera, harnessed for the purpose of capturing requisite instructional visuals.

1. Deployment of digital video technology, facilitating the recording and transcribing of instructional videos.
2. Scanners, facilitating the digitization of images from print sources like magazines and books for seamless integration into teaching materials.
3. Leveraging Optical Character Recognition (OCR) software to convert scanned textual content into digital format, thereby streamlining textual resource management.
4. Utilization of recording software, crucial for capturing essential audio effects and sounds to enhance the learning experience.
5. Harnessing the power of the internet to source relevant course materials, compensating for any potential gaps in educators' teaching resources.

By forging a bridge between the realms of e-learning, e-business education management, and information technology, this study seeks to augment the effectiveness and efficiency of English instruction within language schools. The ultimate beneficiaries are both the students, who gain enhanced learning experiences, and the educators who are empowered to provide more effective English instruction.

In the specific context of my English school, English courses are equipped with KidsCastle's electronic whiteboard, a dynamic tool for engaging students interactively. Within the course, the inclusion of a dice-based activity injects an element of playfulness, akin to a warm-up exercise. The vibrancy of the electronic whiteboard's colors and the engaging games embedded

within it alleviate the notion of learning as a chore. This approach counteracts the potential distraction or restlessness that may arise from a monotonous teaching style. Consequently, the electronic whiteboard mitigates the challenges teachers face and cultivates an environment conducive to learning. Moreover, it nurtures students' interest in the English language, cultivating eagerness for English classes.

Historically, English educators grappled with the necessity of assembling a multitude of teaching aids to infuse dynamism into their lessons. However, with the advent and integration of computer AI, teaching practices have evolved to embrace curriculum alignment and economize time and resources expended on instructional materials. This shift toward technological integration has fostered greater diversity and interest within the curriculum, facilitated by computer AI and electronic resources. This symbiotic relationship between technology and education serves as a valuable adjunct, benefiting both educators and students alike.

### **Research Objectives and Key Points:**

1. **Enhancing English Language Instruction:** The primary objective of this research is to explore the transformative potential of merging e-learning, e-business education management, and information technology education management in the context of English language education. By leveraging advanced technological tools and techniques, this study aims to optimize the efficiency and efficacy of English language instruction.
2. **Bridging Technology and Pedagogy:** This research seeks to bridge the gap between traditional pedagogical methods and technology-driven approaches. It highlights the importance of integrating e-resources into e-learning environments and emphasizes the collaborative efforts of librarians, students, and teachers in updating and refining resources to improve the learning and teaching outcomes continually.
3. **Empowering Learners and Educators:** Through the integration of technology, this study aims to empower both learners and educators. It recognizes that effective teaching methodologies, combined with e-based strategies and future AI advancements, have the potential to elevate learners' confidence, enthusiasm, and engagement in English language education.
4. **Interactive Pedagogy:** The research advocates for a shift from conventional teaching methods to interactive pedagogy, where both teachers and students actively participate in the learning process. It emphasizes the role of technology in creating an inclusive and engaging learning environment.
5. **Language Acquisition and Transformation:** The study focuses on language acquisition, emphasizing that when a second language becomes an intrinsic form of expression, students' engagement with the language is transformed. This paradigm shift has the potential to eliminate barriers related to personality traits or environmental context that hindered students' embrace of English.
6. **Future of Education:** In conclusion, this research paper calls for a collective commitment to shape the future of education where technology harmoniously intertwines with pedagogy. It envisions an educational ecosystem characterized by collaboration, innovation, and shared growth.
7. **Practical Implications:** The findings of this research suggest practical implications for educators, emphasizing the need to adapt teaching methods, embrace technology, and create a learner-centric educational landscape. It also underscores the importance of continuous collaboration and improvement in the realm of education.
8. **Transformation through Technology:** Ultimately, this study highlights the transformative potential of technology in education and its capacity to revolutionize the teaching and learning process. It encourages educators and institutions to embrace technological advancements to enhance the quality of education and prepare students for the challenges of the modern world.

### **DISCUSSION**

The culmination of this study's investigation into the confluence of e-learning, e-business education management, and information technology education management within English instruction at the language schools affiliated with Kaysersberg Education Group has yielded profound insights. The transformative forces of modernization, scientific innovation, computer-assisted pedagogy, and the emerging horizons of Electronicalization and future AI represent pivotal reforms in human civilization. This research underscores the imperative of embracing progressive methodologies by discarding rigid teaching paradigms and harnessing diverse technological softwares. The objective lies in unearthing novel teaching approaches, transcending the traditional teacher-centric format to usher in an era of interactive pedagogy, wherein each participant assumes an active role. Within this orchestrated narrative, both educators and learners engage in a reciprocal process of learning and maturation.

The profound impact of such an approach surfaces when the acquisition of a second language evolves from an alien concept into an intuitive, internalized form of linguistic expression. This paradigm shift enables learners to shed apprehensions rooted in personality traits or environmental contexts, eliminating the fear or estrangement that English may have once evoked. It is, therefore, imperative that effective teaching methodologies, synergized with E-based techniques or impending AI advancements, be embraced with anticipation. This holds true particularly within the realm of English instruction, where heightened confidence and enthusiasm represent generational transitions. As we collectively engage in this transformative journey, our shared future beckons, replete with the promise of fostering an educational landscape characterized by collaboration, innovation, and collective

growth.

The evolution of the times, the invention of science, the good use of computers in teaching, the transformation of Electronicalization or the future AI are all major reforms in human civilization. Only continuous progress can be made by changing rigid teaching methods and using different technological soft topics in an attempt to find out another teaching method, so that teaching is no longer a performance by the teacher alone, but improved into an interactive teaching theater, so that everyone can play a role. Under the arrangement of the plot, teachers and students learn and grow through interaction.

When the second language no longer makes students feel strange, but gradually internalizes the language expression of their inner intuition, this kind of learning can make every student not afraid of English because of their personality or environment, or feel strange and repelled. Therefore, effective teaching methods, combined with E-based or future AI, are full of expectations. For English teaching, more confidence and enthusiasm will be a cross-generational change.

### CONCLUSION

In the process of this study, I have delved into the intersection of e-learning, e-business education management, and information technology education management, focusing on their synergy in English language teaching within the language schools of Kaisersberg Education Group. The dynamic evolution of our times, the advent of scientific breakthroughs, the judicious integration of computers in education, and the transformation ushered in by Electronicalization and the prospects of future AI represent profound reforms within human civilization. This research underscores the imperatives of dynamic progress, advocating for the abandonment of rigid teaching methodologies in favor of innovative technological approaches that yield diverse pedagogical insights.

This study advocates for a paradigm shift from the conventional model of teaching, where educators act as sole performers, to an interactive pedagogical theater where both teachers and students play integral roles. By doing so, education transforms from a unidirectional process into a mutual journey of learning and growth, facilitated by technological tools and their seamless integration. As the language barrier dissipates and students internalize the language through intuitive expression, English learning evolves into a familiar and approachable endeavor. This transformation has the potential to eradicate the apprehension and disengagement often associated with learning a new language due to personal traits or environmental circumstances.

I look forward to researching effective teaching methodologies synergized with E-based approaches or imminent AI advancements hold great promise. The implications of these advancements are far-reaching, particularly in the domain of English language education. Increased student confidence, enthusiasm, and engagement are poised to catalyze a generational shift in learning dynamics. This transformative journey beckons us to collectively shape the future of education—a landscape characterized by collaboration, innovation, and shared growth.

In conclusion, our study underscores the potential of fusing technology with pedagogy to not only enhance English language education but also revolutionize the very essence of how teaching and learning take place. By embracing the synergy of e-learning, e-business education management, and information technology education management, we pave the way for an inclusive, interactive, and learner-centric educational landscape that honors the potential of every individual and collectively propels us towards an inspiring future of education.

### REFERENCES

- Abuzaid, R. A., & Singh, D. (2007). The Usage of Educational E-resources in Developing Countries: A Case Study of Implementation in Saudi Arabia. Paper presented at Redesigning Pedagogy: Culture, Knowledge, and Understanding Conference, May 28-30, 2007, Singapore.
- Ally, M. (2004). Foundations of educational theory for online learning. In T. Anderson & F. Elloumi (Eds.), *Theory and practice of online learning* (pp. 3-31). Athabasca, AB: Athabasca University.
- Chaudhry, L. (1999). Cyber-school's never out. Retrieved from <http://www.wired.com/news/news/culture/story/21328.html>
- Cobbah, A. A. (2004). The Role Librarians in Student-Centered Learning: the Case of Students from the Disadvantaged Communities in South Africa. *The International Information & Library Review*, 36, 263-271.
- Darling-Hammond, L. (2000). Teacher Quality and Student Achievement: A Review of State Policy Evidence. *Education Policy Analysis Archive*, 8(1), 1068-2341.
- Goe, L. (2007). The Link Between Teacher Quality and Student Outcomes: A Research Synthesis. *National Comprehensive Centre for Teacher Quality*, sponsored under government cooperative agreement number.
- Hamid, S. R. A., Hassan, S. S. S., & Ismail, N. A. H. (2012). Teaching Quality and Performance Among Experienced Teachers in Malaysia. *Australian Journal of Teacher Education*, 11(5).
- Hardan, A. A. (2013). Language Learning Strategies: A General Overview. *Procedia – Social and Behavioral Sciences*, 2(1), 18-30.
- Harris, D. N., & Rutledge, S. A. (2007). Models and Predictors of Teacher Effectiveness: A Review of the Literature with Lessons from (and for) Other Occupations.
- Licorish, S. A., George, J. L., Owen, H. E., & Daniel, B. (2017). “Go Kahoot!” Enriching Classroom Engagement, Motivation and Learning Experience with Games. *Proceedings of the 25th International Conference on Computers in Education*. New

- Zealand: Asia-Pacific Society for Computers in Education.
- Maulidar, K., Gani, S. A., & Samad, I. A. (2019). Teacher's Strategies in Teaching Speaking For Cadets. *English Education Journal (EEJ)*, 10(1), 80-94.
- Pandey, V., & Mishra, P. B. (2016). Assess the Relationship Between Selfies and Self Esteem Among University Students. *IOSR Journal of Humanities and Social Science (IOSR- JHSS)*, 22(12).
- Rosenquist-Buhler, C. (1996). New partners in distance education: linking up to libraries. *Library Administration & Management*, Fall, 220-5.
- Sharma, D. R. (2018). Action Research on Improving Students' Speaking Proficiency in Using Cooperative Storytelling Strategy. *Journal of NELTA Surkhet*, 5(1), 97-105.
- Sikand, D., & Kauts, A. (2016). Relationship of Teacher Effectiveness, Teacher Stress and Teacher Commitment with Different Dimensions of Creative Management. *Scholarly Research Journal for Humanity Science & English Language*, 5(25).
- University of Texas (2000). Distance education: a primer, student issues. Retrieved from <http://www.utexas.edu/cc/cit/de/deprimer/student.html>
- Waxman, C. H., Lin, M. F., & Michko, G. M. (2003). A Meta-Analysis of The Effectiveness of Teaching and Learning With Technology on Student Outcomes. Naperville, Illinois: Learning Point Associates.
- Zorio, Z. M. (2018). Using ICTs to boost students' motivation in the EFL classroom.

## Convolution Neural Network (CNN) Based Phishing Attack Detection Model for E-Business in Enterprise Information Systems

Brij B. Gupta <sup>1,\*</sup>  
Akshat Gaurav <sup>2</sup>  
Kwok Tai Chui <sup>3</sup>

\*Corresponding author

<sup>1</sup> Department of Computer Science and Information Engineering, Asia University, Taiwan, & Lebanese American University, Beirut, 1102, Lebanon, bbgupta@asia.edu.tw

<sup>2</sup> Ronin Institute, Montclair, NJ, USA, akshat.gaurav@ronininstitute.org

<sup>3</sup> Hong Kong Metropolitan University (HKMU), Hong Kong, jktchui@hkmu.edu.hk

### ABSTRACT

The continued prevalence of phishing attacks highlights the need of research into the creation of reliable detection models for this pervasive online danger to e-business. Using a dataset procured from Kaggle, this study proposes a Convolutional Neural Network (CNN)-based method for identifying phishing scams. Using two Conv1D layers, our model successfully distinguishes between safe and harmful websites. Training results were quite encouraging, with a loss of just 0.077525 and an accuracy of 0.972125 throughout the process. These findings validate our CNN-based phishing attack detection model's sturdiness and adaptability. Our results not only provide a useful tool for spotting phishing attacks but also shed light on the possibilities of CNNs, and in particular Conv1D layers, in the realm of cybersecurity. This study is an important contribution to the ongoing effort to counter the rising danger of phishing attempts and improve the safety of e-business users worldwide.

*Keywords:* CNN, e-business, electronic commerce, phishing.

### INTRODUCTION

The rapid expansion of online enterprises has brought us a new age of unmatched ease, accessibility, and trade. Unfortunately, with this digital development has come a strong foe: phishing attacks (Almomani et al., 2022). Individuals and businesses alike face a serious risk while doing business online because of phishing, the fraudulent effort to gain sensitive information (Gupta & Jain, 2020; Meddah & Guerroujji, 2022; Onyebuchi et al., 2022; Singh et al., 2022). Victims of these attacks often suffer financial ruin and have their faith in digital services eroded as a result. The need of creating reliable and effective systems for identifying phishing attempts has grown in response to this growing threat. This research introduces a novel approach to this problem by introducing a Phishing Attack Detection Model built specifically for the context of online businesses using Convolutional Neural Networks (CNNs). The use of CNNs (Almomani et al., 2022; Chopra et al., 2022; Hasib et al., 2021; Kadri et al., 2022; Li et al., 2022; Tembhurne et al., 2022) in cybersecurity, and more especially phishing detection, is an intriguing new direction, and one that we investigate. Investigating the performance of this CNN-based model, trained and tested using Kaggle data, is central to this study. This model's design includes Conv1D layers, which show promise in capturing complex patterns within the dataset and improving the model's ability to identify both established and novel phishing attack routes.

Our research delves further into the confusion matrix and other metrics for measuring the model's efficacy throughout both training and testing phases. Together, these indicators show that the model can accurately distinguish between benign and harmful "Phishing" efforts and "Normal" E-business activity. Protecting E-commerce and the customers that use it is of utmost importance as we go forward in the world of cyber security. This research not only fills that gap, but it also adds to the ongoing discussion on how to best put cutting-edge deep learning methods like CNNs to use in the service of bettering online safety. Our studies are directed at strengthening the underpinnings of E-business by illuminating the complex relationship between technology and security in this field, thereby guaranteeing the continued primacy of trust and safety in the digital era.

### RELATED WORK

Researchers concluded that phishing attacks are a significant threat to e-business (Almomani et al., 2022; Gaurav et al., 2022; Gupta & Jain, 2020; Mishra et al., 2018). Banday et al. (Banday & Qadri, 2011) provide an overview of various phishing approaches, including vishing, spear phishing, pharming, keyloggers, malware, and web Trojans. Dadkhah et al. (Dadkhah et al., 2016) discuss different types of phishing attacks and possible detection techniques for them. Jain et al. (Jain et al., 2021) explain the details of various techniques used by phishing attacks to acquire sensitive information and provide the advantages

and disadvantages of the various anti-phishing technologies Overall, the papers suggest that phishing attacks are a complex and evolving threat to e-business and that there are various techniques available to detect and prevent them.

Recently researchers suggest that deep learning and machine learning models are effective for detecting phishing attacks. Almousa et al. (Almousa et al., 2022) found that deep learning models, including Long Short-Term Memory-based detection models, Fully Connected Deep Neural Network-based detection models, and convolutional neural network-based detection models, achieved high accuracy for phishing website detection. Aljofey et al. (Aljofey et al., 2020) proposed a fast deep learning-based solution model that uses a character-level convolutional neural network (CNN) for phishing detection based on the URL of the website, achieving high accuracy on benchmark datasets. Aljabri et al. (Aljabri & Mirza, 2022) investigated the effectiveness of applying machine learning models in detecting phishing websites and found that the Random Forest algorithm achieved the highest accuracy for both datasets. Atre et al. (Jha et al., 2022) evaluated deep learning models for three phishing detection methods and found that combining results from individual models can improve the effectiveness of detecting cloud-based phishing attacks. Overall, the papers suggest that deep learning and machine learning models are effective for detecting phishing attacks, and different models can be used depending on the specific context and features of the phishing attacks.

### PROPOSED APPROACH

The model architecture you've provided is a Convolutional Neural Network (CNN) designed for the task of phishing attack detection in E-business. Let's break down the architecture:

- Two Conv1D (1-dimensional convolutional) layers are the foundation of the model. With 32 output channels and a kernel size of 3, the first Conv1D layer filters the input data using 32 separate filters of size 3. Similar to the first Conv1D layer, but with 128 more output channels, is the second. These layers are critical for detecting elements related to phishing assaults because they capture local trends in the input data.
- Rectified Linear Unit (ReLU) activation functions are used after each Conv1D layer. ReLU allows the network to learn intricate connections in the data by introducing non-linearity via the replacement of negative values with zero.
- MaxPooling1D Layers: These are utilised after the ReLU activation. By choosing the highest value inside a 3-by-3-pixel frame, these layers compress the underlying data set. To make the model more computationally efficient, this aids in downsampling the feature maps while keeping the most important information.
- Flattening the output of higher-dimensional layers into a vector space is the job of the Flatten layer. To link the convolutional layers to the fully connected layers, this is required.
- After the convolutional layers are two fully linked (Linear) layers. To help the model pick up on subtle nuances in the interactions between the simplified feature maps, the first Linear layer introduces a dense layer with 128 units. After the first Linear layer, non-linearity is introduced by ReLU activation. To avoid overfitting, a dropout layer is included following the ReLU activation. Providing the ultimate categorization is a second Linear layer with 2 units as the output layer.
- The model comprises 22,562 parameters in total, all of which may be trained to improve accuracy. The weights and biases of the convolutional and fully connected layers are examples of such parameters.
- Data input sizes of 32 (batch size) and 3 (sequence length) are accepted by the model. There will be 32 total results since the batch size is 32 and there are two types of results ("Normal" and "Phishing").



```

=====
Layer (type:depth-idx)                Output Shape                Param #
=====
DeepLearning                          [32, 2]                    --
├─Conv1d: 1-1                          [32, 32, 3]                1,568
├─ReLU: 1-2                            [32, 32, 3]                --
├─MaxPool1d: 1-3                       [32, 32, 1]                --
├─Conv1d: 1-4                          [32, 128, 3]               4,224
├─ReLU: 1-5                            [32, 128, 3]               --
├─MaxPool1d: 1-6                       [32, 128, 1]               --
├─Flatten: 1-7                         [32, 128]                  --
├─Linear: 1-8                          [32, 128]                  16,512
├─ReLU: 1-9                            [32, 128]                  --
├─Dropout: 1-10                       [32, 128]                  --
├─Linear: 1-11                         [32, 2]                    258
=====
Total params: 22,562
Trainable params: 22,562
Non-trainable params: 0
Total mult-adds (M): 1.09
=====
Input size (MB): 0.01
Forward/backward pass size (MB): 0.16
Params size (MB): 0.09
Estimated Total Size (MB): 0.25
=====

```

**Figure 1: Model Architecture**

## RESULTS AND DISCUSSION

In our research, we used PyTorch to build a Convolutional Neural Network (CNN) for detecting phishing attacks, and we tested it in a CPU setting using a Kaggle notebook. We monitored the model's progress in terms of training loss, training accuracy, test loss, and test accuracy throughout the course of 10 training epochs. The model had a training loss of 0.324944 and a training accuracy of 0.857125 at the beginning of training (epoch 0). The test loss was reduced to 0.176080 on the test dataset, and the test accuracy was improved to 0.938988, both of which are very good results. The model dramatically enhanced itself as training progressed. Training loss was minimised to 0.136915 at the end of period 2 with an accuracy of 0.951250%. Additionally, the test loss was brought down to 0.128674, and the test accuracy was increased to 0.956349. Training accuracy of 0.963875 and test accuracy of 0.964782 were attained in epochs 4 and 5, respectively, demonstrating the model's capacity to generalise its learnings.

As training progressed, the model continued to improve. The best training loss was 0.077525 and the best training accuracy was 0.972125 in epoch 9. At 0.090748, the test loss was at its lowest, while at 0.967262, the test accuracy was at its highest. These results demonstrate the model's efficiency in differentiating phishing assaults from real E-business endeavours. Its reliability in detecting phishing assaults in real-world settings is supported by its strong generalisation, as seen by its performance on the test dataset. In conclusion, our research highlights the promise of CNN-based models in bolstering online security and shielding E-businesses from ever-evolving dangers. It also demonstrates the viability of incorporating such models in CPU systems, opening them up to a wide range of potential uses in the field of cybersecurity.

## Accuracy and Loss Curves

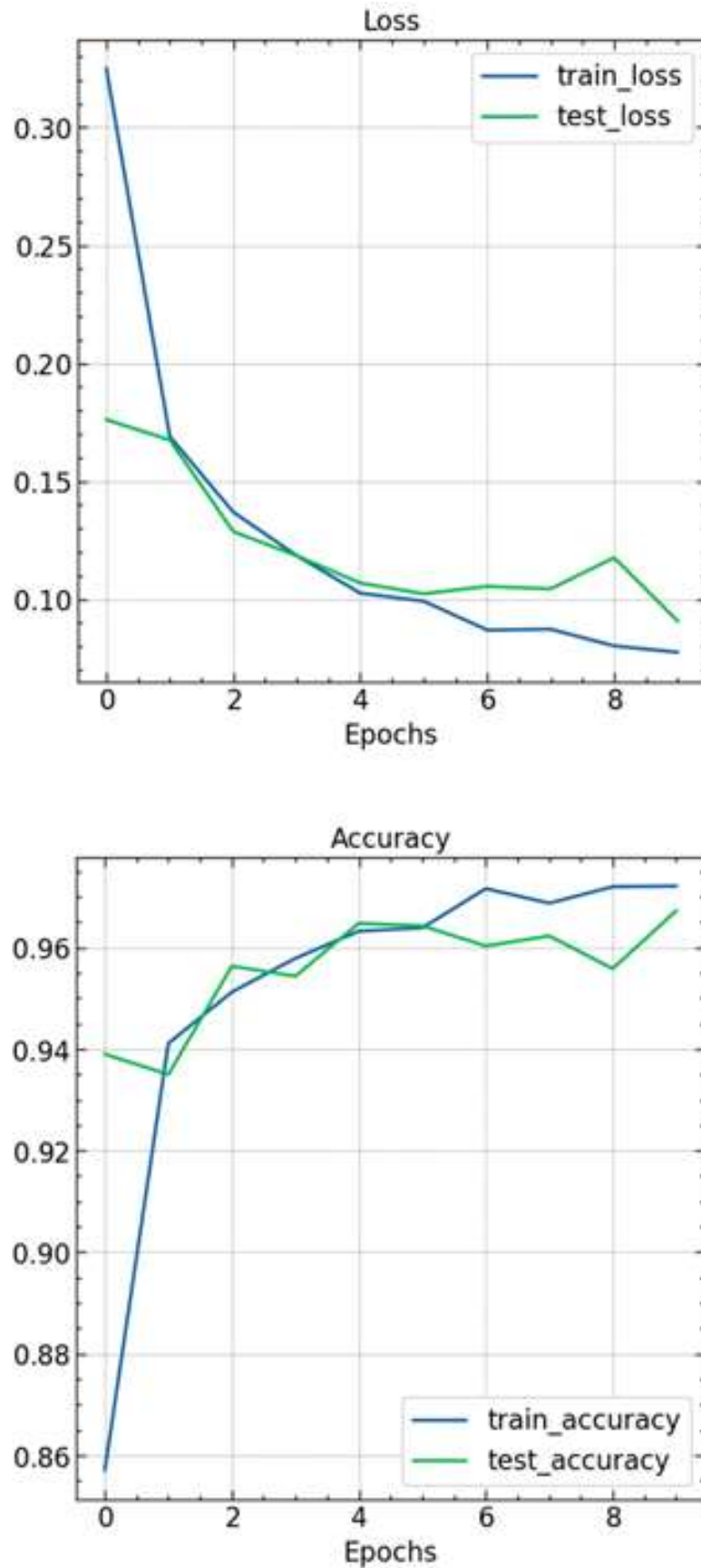
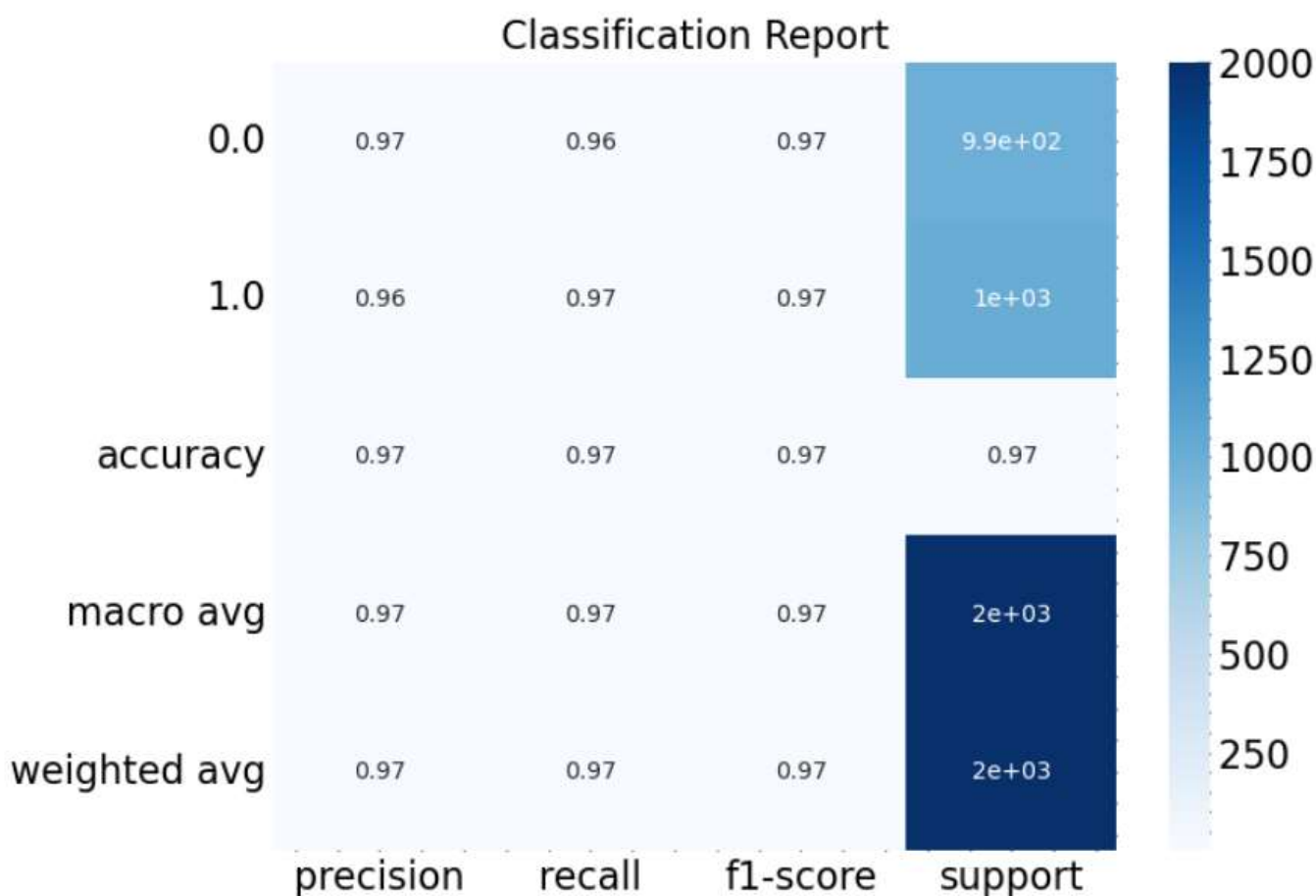

Figure 2: Accuracy and Loss Curve

### Classification Report

Our Phishing Attack Detection Model uses convolutional neural networks (CNNs), and the classification report gives a thorough assessment of the model's ability to discriminate between two classes in the dataset: "Normal" and "Phishing." These measures are critical for assessing the model's performance. The "Normal" class has a precision of 0.97, measuring the reliability of the class's positive predictions. When the model classifies an occurrence as "Normal," it is 97% accurate. A recall of 0.96 indicates that 96% of all real-world "Normal" cases are captured by the model, representing the accuracy with which it identifies such instances. For the "Normal" class, the model's F1-score of 0.97 demonstrates a good compromise between accuracy and recall. Altogether, these indicators point to a very high accuracy and dependability in determining "Normal" occurrences. The model is 96% accurate at classifying instances as "Phishing," as shown by the accuracy value of 0.96.

Similarly, the recall for this category is 0.97, meaning that 97% of real-world "Phishing" cases are captured by the model. Again, the model's outstanding performance in identifying "Phishing" cases is shown by the "Phishing" class's F1-score of 0.97. Measured by the percentage of properly categorised occurrences, the model achieves an overall accuracy of 97%. This impressive precision demonstrates the model's prowess in identifying "Normal" from "Phishing" scenarios.



**Figure 3: Classification Report**

### Confusion Matrix

The confusion matrix provides a detailed breakdown of our CNN-based Phishing Attack Detection Model's classification performance for the "Normal" and "Phishing" classes. In this matrix, the two classes are represented as rows and columns: "Normal" and "Phishing."

- True Positives (TP): The model correctly predicted 983 instances as "Phishing."
- True Negatives (TN): It accurately classified 952 instances as "Normal."
- False Positives (FP): The model incorrectly predicted 36 instances as "Phishing" when they were actually "Normal."
- False Negatives (FN): It made 29 incorrect predictions, classifying instances as "Normal" when they were "Phishing."

To break it down further, in the context of our model's performance:

- For "Normal," there were 952 true positives (correctly identified as "Normal") and 36 false positives (incorrectly classified as "Phishing").
- For "Phishing," there were 983 true positives (correctly identified as "Phishing") and 29 false negatives (incorrectly classified as "Normal").

These results show that the model is quite good at distinguishing between "Normal" and "Phishing" cases, with minimal false positives. The large proportion of correct predictions suggests that the model is able to accurately capture "Normal" and "Phishing" scenarios. False positives and false negatives occurred, although at low rates, indicating that the model's performance is highly trustworthy, as is typical in classification tasks. These results corroborate the classification report's claims of high accuracy, recall, and F1-scores, demonstrating the model's ability to accurately discriminate between these two categories crucial to ensuring the safety of online businesses.

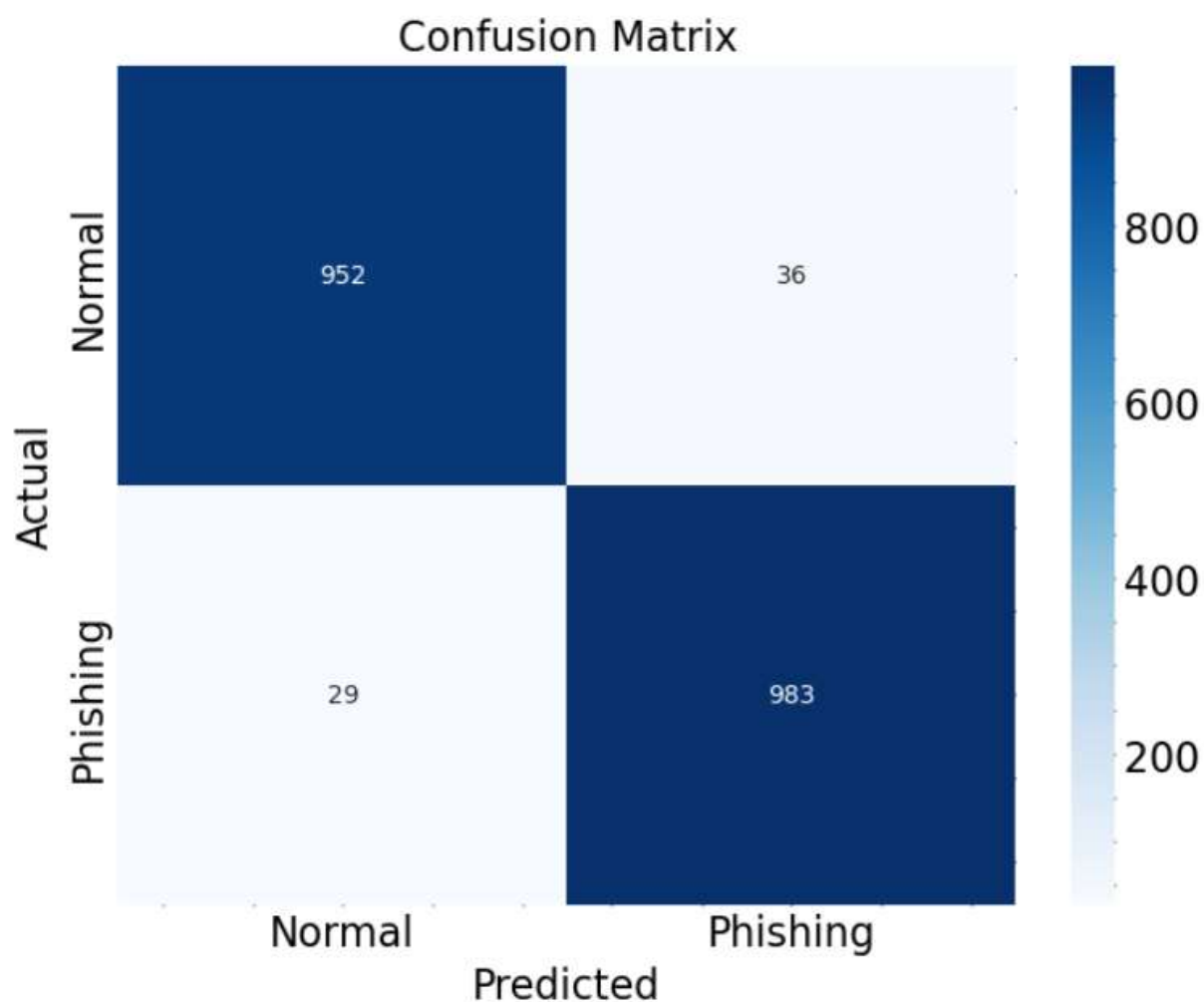

**Figure 4: Confusion Matrix**

### CONCLUSION

In this research, we introduced a Phishing Attack Detection Model built on top of a Convolutional Neural Network (CNN) and optimised for use in online businesses. Our model, developed using a dataset obtained from Kaggle, demonstrates the potential of deep learning in tackling this critical topic, since phishing attempts have become more common in the realm of electronic commerce and need strong and adaptable solutions. Both the training and testing results of our model have been quite

encouraging. Training results show it is quite good at learning and generalising from the data supplied, with a loss of only 0.077525 and an accuracy of 0.972125. Its test loss was 0.090748 and its test accuracy was 0.967262, further demonstrating its superiority in detecting phishing attempts in realistic E-business settings. Our CNN-based model's effectiveness in this setting demonstrates the continued relevance of deep learning methods in the field of cyber security. The use of Conv1D layers also demonstrates their efficiency in collecting complex patterns within the dataset, an important feature for differentiating between benign and harmful cyber-activity. The strategies used by cybercriminals are constantly changing in tandem with the development of e-commerce. Even though phishing attempts are still a major problem, our strategy is a major improvement in terms of protecting online businesses. It has potential uses outside the scope of this investigation and may serve as a springboard for further work in the area of cyber security.

#### ACKNOWLEDGEMENT

This research work is supported by National Science and Technology Council (NSTC), Taiwan Grant No. NSTC112-2221-E-468-008-MY3.

#### REFERENCES

- Aljabri, M., & Mirza, S. (2022). *Phishing attacks detection using machine learning and deep learning models*. 175–180.
- Aljofey, A., Jiang, Q., Qu, Q., Huang, M., & Niyigena, J.-P. (2020). An Effective Phishing Detection Model Based on Character Level Convolutional Neural Network from URL. *Electronics*, 9(9), 1514. <https://doi.org/10.3390/electronics9091514>
- Almomani, A., et al. (2022). Phishing website detection with semantic features based on machine learning classifiers: A comparative study. *International Journal on Semantic Web and Information Systems (IJSWIS)*, 18(1), 1–24.
- Almoussa, M., Zhang, T., Sarrafzadeh, A., & Anwar, M. (2022). Phishing website detection: How effective are deep learning-based models and hyperparameter optimization? *Security and Privacy*, 5(6), e256.
- Banday, M. T., & Qadri, J. A. (2011). Phishing-A growing threat to e-commerce. *arXiv Preprint arXiv:1112.5732*.
- Chopra, M., et al. (2022). Analysis & prognosis of sustainable development goals using big data-based approach during COVID-19 pandemic. *Sustainable Technology and Entrepreneurship*, 1(2), 100012.
- Dadkhah, M., Jazi, M. D., Mobarakeh, M. S., Shamshirband, S., Wang, X., & Raste, S. (2016). An overview of phishing attacks and their detection techniques. *International Journal of Internet Protocol Technology*, 9(4), 187–195.
- Gaurav, A., et al. (2022). A comprehensive survey on DDoS attacks on various intelligent systems and its defense techniques. *International Journal of Intelligent Systems*, 37(12), 11407–11431.
- Gupta, B. B., & Jain, A. K. (2020). Phishing attack detection using a search engine and heuristics-based technique. *Journal of Information Technology Research (JITR)*, 13(2), 94–109.
- Hasib, K. M., Towhid, N. A., & Islam, M. R. (2021). Hsdml: A hybrid sampling with deep learning method for imbalanced data classification. *International Journal of Cloud Applications and Computing (IJCAC)*, 11(4), 1–13.
- Jain, A. K., et al. (2021). A survey of phishing attack techniques, defence mechanisms and open research challenges. *Enterprise Information Systems*, 1–39.
- Jha, B., Atre, M., & Rao, A. (2022). *Detecting Cloud-Based Phishing Attacks by Combining Deep Learning Models*. 130–139.
- Kadri, O., Benyahia, A., & Abdelhadi, A. (2022). Tifinagh Handwriting Character Recognition Using a CNN Provided as a Web Service. *International Journal of Cloud Applications and Computing (IJCAC)*, 12(1), 1–17.
- Li, S., Qin, D., Wu, X., Li, J., Li, B., & Han, W. (2022). False alert detection based on deep learning and machine learning. *International Journal on Semantic Web and Information Systems (IJSWIS)*, 18(1), 1–21.
- Meddah, I. H., & Guerroudji, F. (2022). Business process discovery using process mining techniques and distributed framework. *International Journal of Cloud Applications and Computing (IJCAC)*, 12(1), 1–17.
- Mishra, A., et al. (2018). Intelligent phishing detection system using similarity matching algorithms. *International Journal of Information and Communication Technology*, 12(1–2), 51–73.
- Onyebuchi, A., Matthew, U. O., Kazaure, J. S., Okafor, N. U., Okey, O. D., Okochi, P. I., Taiwo, J. F., & Matthew, A. O. (2022). Business demand for a cloud enterprise data warehouse in electronic healthcare computing: Issues and developments in e-healthcare cloud computing. *International Journal of Cloud Applications and Computing (IJCAC)*, 12(1), 1–22.
- Singh, A., et al. (2022). Distributed denial-of-service (DDoS) attacks and defense mechanisms in various web-enabled computing platforms: Issues, challenges, and future research directions. *International Journal on Semantic Web and Information Systems (IJSWIS)*, 18(1), 1–43.
- Tembhurne, J. V., Almin, M. M., & Diwan, T. (2022). Mc-DNN: Fake news detection using multi-channel deep neural networks. *International Journal on Semantic Web and Information Systems (IJSWIS)*, 18(1), 1–20.

## Exploring the Interplay Between Online Dating, Cyberpsychology, and the Dynamics of Self-Representation and Deception: A Case Study on Tinder

Gerrard Li <sup>1,\*</sup>  
Chen-Yuen Kang <sup>2</sup>

\*Corresponding author

<sup>1</sup> Department of Information Management, National Chung Cheng University, Taiwan, [junhone0703@icloud.com](mailto:junhone0703@icloud.com)

<sup>2</sup> Department of Information Management, National Chung Cheng University, Taiwan, [kangchenyuan62@gmail.com](mailto:kangchenyuan62@gmail.com)

### ABSTRACT

This study investigates the intricate dynamics of self-presentation and deception in the realm of online dating, with Tinder as the central focus. Our research question, "How do Tinder users' motivations influence self-representation and deception in online dating?" guides this comprehensive study. To explore this question, qualitative research methods were employed. We conducted a thematic analysis on data collected from diverse online forums and communities related to online dating and Tinder. The thematic analysis allowed us to identify recurring patterns and themes, shedding light on the psychological motivations and implications intertwined with self-presentation and deception. Our preliminary findings reveal six significant facets within the online dating landscape: (1) Motivation, (2) Self-Presentation, (3) Emotional Impact, (4) Superficial Judgment, (5) Deceptive Practices, and (6) Online Dating's Wider Impact. These findings not only resonate with existing literature on online dating behaviors but also unveil previously unexplored nuances in this digital domain. This research contributes to the evolving field of cyberpsychology, offering valuable insights into human behavior in the digital age. Furthermore, it holds practical implications for fostering ethical and authentic practices within the realm of online dating, promising a foundation for future research and transformative applications in this dynamic domain.

*Keywords:* Online Dating, Self-Presentation, Deception, Cyberpsychology and Authenticity.

### INTRODUCTION

In recent years, the world of online dating has witnessed a revolutionary transformation, redefining the way individuals seek and cultivate romantic connections (Valkenburg & Peter, 2007). This paradigm shift is underscored by the remarkable growth of the online dating industry, which, as of 2023, boasted a global market size estimated at 9.65 billion USD (Statista, 2023). According to recent surveys, 35% of modern relationships are now initiated in the digital sphere, highlighting the pervasive influence of online dating platforms (EarthWeb, 2023). As technological advancements continue to evolve, traditional modes of offline courtship have ceded ground to the expansive digital landscape, where online dating platforms have emerged as dominant facilitators of romantic encounters (Naji Bajnaid & Elyas, 2017).

Our journey into this captivating realm began by engaging with individuals on Tinder—an intimate voyage that exposed us to the depths of human emotions, vulnerabilities, struggles, and triumphs shared within the confines of a dating app (Timmermans & De Caluwé, 2017). These personal encounters resonated deeply, not only shaping our own understanding but also igniting an insatiable curiosity to delve further into the psychological motivations and implications intertwined with self-presentation and deception in the realm of online dating. Our motivation is underpinned by the abundant research opportunities within this field. Hence, this thesis embarks on a captivating exploration of the intricate relationship between online dating, self-representation, deception, and cyberpsychology, using Tinder as an illuminating case study (Sumter et al., 2017).

The core objective of this thesis is to unveil the dynamics of self-representation and deception within the context of online dating, with Tinder as our primary focus (Sumter et al., 2017). By scrutinizing the experiences and behaviors of individuals within this specific platform, our aim is to gain a profound understanding of the psychological motivations and implications intertwined with self-presentation and deception (Toma & Hancock, 2010). This journey traverses existing literature, theoretical frameworks, and empirical research, contributing valuable insights to the realm of cyberpsychology while elucidating the distinct challenges and opportunities arising within the Tinder ecosystem (Bonilla-Zorita et al., 2023). Research Question: Exploring Tinder users' motivations and their impact on self-representation and deception.

### LITERATURE REVIEW

In recent years, the world of online dating has experienced a transformative shift, reshaping the landscape of how individuals seek and establish romantic connections (Gatter & Hodkinson, 2016). This section reviews key studies and theories that

contribute to our understanding of cyberpsychology, including topics such as online self-presentation, deception, and the impact of technology on relationships (Ranzini & Lutz, 2017).

### Literature Review on Mobile Dating Applications

Mobile dating apps have facilitated a shift towards more convenient and efficient ways of connecting, exemplified by Tinder's swiping mechanism for casual dating, which simplifies the process of finding potential matches based on mutual interest and attraction, while platforms like eHarmony employ comprehensive compatibility questionnaires to cater to those seeking long-term relationships, enhancing the chances of successful matches. Furthermore, the careful curation of online identities through profile pictures and information has become pivotal in mobile dating app usage, with users meticulously selecting their most attractive photos and crafting engaging bios to maximize their appeal and initiate meaningful conversations (Evans & Blount-Hill, 2022). The success of these apps, which underpins the value of this thesis, can be attributed to their ability to cater to a wide range of user behaviors and preferences (Alexopoulos et al., 2020).

Mobile dating applications not only facilitate personal connections but also offer significant business value by providing a solution to several dating-related issues. These apps efficiently address challenges such as the limited time and opportunities for traditional dating, helping individuals overcome geographical barriers and busy lifestyles. Moreover, they enable users to filter potential matches based on their preferences, reducing the uncertainty often associated with blind dates (Evans & Blount-Hill, 2022). By addressing these issues, mobile dating apps contribute to the broader dating ecosystem, making it easier for people to find compatible partners and enhancing the overall dating experience, which in turn demonstrates their lasting relevance and value (Comunello et al., 2021).

### Literature Review on Cyberpsychology

Cyberpsychology, a field dedicated to understanding psychological processes and behaviors in online environments (Kirwan, 2010), offers valuable insights into the complexities of online dating. Research in cyberpsychology has examined how individuals construct their online identities and the motivations behind self-presentation (Fullwood et al., 2016).

It has also delved into the phenomenon of deception in online dating, exploring the reasons why individuals may engage in deceptive practices and the consequences of such behavior (Smith, 2023). Additionally, the literature highlights the influence of technology on relationship formation and the psychological implications of online interactions (Lieberman & Schroeder, 2020).

### The Connection Between Online Dating and Cyberpsychology

To further elucidate the connection between online dating and cyberpsychology, we summarize key literature and arguments on the relationship between online dating and cyberpsychology in Table 1. By combining the insights derived from this literature review with an exploration of the correlation between online dating and cyberpsychology, this chapter lays the foundation for a comprehensive understanding of the dynamics of self-representation and deception within the context of online dating (Ellison et al., 2006; Gibbs et al., 2011).

Table 1: Literature and Arguments on the Connection Between Online Dating and Cyberpsychology

Literature	Argument
Valkenburg and Peter (2007)	Demographic predictors and dating anxiety impact online dating behavior, with age as a significant factor supporting the rich-get-richer hypothesis.
Kirwan (2010)	Significance of cyberpsychology in studying human interactions with technology, including the Internet, mobile computing, virtual reality, and emerging trends.
Cali et al. (2013)	The stigma surrounding online relationship initiation influences women's self-protective behaviors and decision-making processes.
Coghlan and Kirwan (2013)	Relationship between gender-bending online and individuals' "Need for Achievement," with gender and goal-oriented virtual environments as influencing factors.
Meredith (2020)	Conversation analysis (CA) aids in understanding online communication dynamics and differences between online and offline communication.
Wiederhold (2021)	Impact of the COVID-19 pandemic on the online dating industry, including increased usage, reduced stigma, and continued interest in online dating platforms.

## RESEARCH METHODS

In this study, we employed qualitative research methods to delve into the intricate relationship between online dating, self-presentation, deception, and cyberpsychology within the context of Tinder. Our choice of qualitative methods was driven by the

<sup>1</sup> "Gender-bending online" refers to individuals assuming different gender identities in digital contexts. This practice is studied in cyberpsychology to understand its motivations and consequences.



exploratory nature of our research, aiming to gain deeper insights into the lived experiences and motivations of Tinder users (Creswell & Poth, 2016). Our data collection process primarily involved the systematic exploration of various online forums, communities, and discussion platforms related to online dating and Tinder (Cantrell & Lupinacci, 2007). We selected a diverse range of platforms to ensure a comprehensive understanding of user experiences and behaviors within the Tinder ecosystem.

To capture a broad spectrum of perspectives, we adopted a purposive sampling strategy. This strategy allowed us to focus on forums and communities with varied user demographics and preferences, ensuring a well-rounded representation of Tinder users. The qualitative data collected from online forums and communities underwent rigorous thematic analysis (Corbin, 1998). Thematic analysis is a systematic approach used to identify, analyze, and report patterns or themes within qualitative data (Braun & Clarke, 2006). It enabled us to uncover recurring ideas, concepts, and experiences related to self-presentation and deception on Tinder.

We prioritized ethical considerations throughout our research process. We meticulously adhered to the terms of service and guidelines of the online forums and communities we used as data sources (Bryman, 2016). No personally identifiable information or sensitive data was collected or shared, preserving the anonymity and privacy of forum participants (Israel & Iain, 2006).

### CASE DESCRIPTION

Tinder, launched in 2012, has emerged as a prominent player in the online dating sphere, with 75 million users globally as of 2023. This substantial market presence is attributed to its unique approach as a location-based dating app, facilitating user connections by enabling them to swipe right for potential matches based on mutual interest and attraction. This mobile application has not only revolutionized the dating landscape but has also stirred discussions about the impact of technology on modern relationships (Sumter et al., 2017). Understanding Tinder's unique dynamics is essential for exploring the complexities of self-presentation and deception in the realm of online dating (Gatter & Hodkinson, 2016).

### PRELIMINARY FINDING

In our exploration of online dating within the Tinder context, seven key findings have emerged, closely aligned with cyberpsychology literature. These findings form the basis of our model, as illustrated in Figure 1, which depicts the intricate connection between online dating and cyberpsychological aspects. These key findings are also summarized in Table 2 for a concise overview.

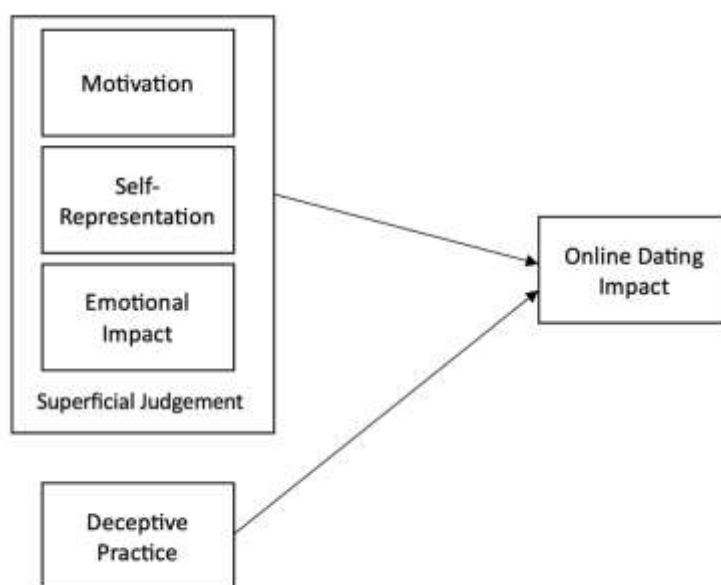

Figure 1: Connection between online dating on Cyberpsychology aspect

Our diagram illustrates the intricate connections within our Tinder-based online dating study, highlighting how user self-presentation, motivations, emotions, and cyberpsychology factors influence rapid appearance-based judgments and deceptive practices, ultimately leading to broader consequences in self-esteem, social connections, and offline dating, as summarized in Table 2.

Table 2. List of Factors Influencing Online Dating and Cyberpsychology

Motivation	Tinder users exhibit diverse motivations, including seeking casual encounters, pursuing long-term relationships, and seeking validation. These motivations echo findings from previous studies (Cali et al., 2013; Valkenburg & Peter, 2007).
Self-Presentation	Users engage in selective self-presentation and impression management strategies. This mirrors identity construction concepts commonly discussed in cyberpsychology (Coghlan & Kirwan, 2013; Kirwan, 2010).
Emotional Impact	Engaging with Tinder evokes a wide range of emotions among users, including excitement, validation, disappointment, and rejection. These emotional responses are closely tied to self-presentation and user motivations (Meredith, 2020).
Superficial Judgement	The emphasis on appearance in Tinder leads to rapid judgments, primarily based on profile photos. This aspect links motivations, self-presentation, and emotional impact (Cali et al., 2013; Valkenburg & Peter, 2007).
Deceptive Practices	Deception within online dating profiles is a common phenomenon, encompassing attribute misrepresentation and photo enhancement. Deceptive practices are intertwined with both user motivations and self-presentation strategies (Smith, 2023).
Online Dating's Wider Impact	Beyond the digital realm, our findings suggest that online dating on Tinder has broader effects on individuals' psychological well-being, self-esteem, self-perception, and social connections. These observations align with the emotional impact and user motivations (Wiederhold, 2021).

These preliminary findings form the foundation of our research model, illustrating the intricate connections between online dating and cyberpsychological aspects. Further research and analysis will provide a more comprehensive understanding of these phenomena and their implications for individuals engaging in online dating on Tinder.

### DISCUSSION AND CONCLUSION REMARK

In our initial study, we embarked on an exploration of key factors shaping the dynamics of online dating on Tinder. Our research has yielded valuable insights into six pivotal aspects: (1) Motivation, (2) Self-Presentation, (3) Emotional Impact, (4) Superficial Judgment, (5) Deceptive Practices, and (6) Online Dating's Wider Impact. These findings not only align with the existing body of literature on online dating behaviors but also unearth previously uncharted nuances within this digital realm.

Our commitment to this research project extends into the future, where we are dedicated to expanding and substantiating our preliminary insights. We acknowledge that these early revelations are just the tip of the iceberg, and we are poised to delve deeper into the contextual nuances that underpin online dating dynamics. Our research will explore the boundaries and conditions that shape these phenomena, incorporating additional data sources to construct a more comprehensive model. This endeavor not only contributes to academic understanding but also holds immense practical value within the ever-evolving landscape of online dating. It serves as a robust foundation for further research, paving the way for meaningful insights and transformative applications in this dynamic domain.

### REFERENCES

- Alexopoulos, C., Timmermans, E., & McNallie, J. (2020). Swiping more, committing less: Unraveling the links among dating app use, dating app success, and intention to commit infidelity. *Computers in Human Behavior*, 102, 172–180. <https://doi.org/10.1016/j.chb.2019.08.009>
- Bonilla-Zorita, G., Griffiths, M. D., & Kuss, D. J. (2023). Dating App Use and Wellbeing: An Application-Based Pilot Study Employing Ecological Momentary Assessment and Objective Measures of Use. *International Journal of Environmental Research and Public Health*, 20(9), 5631. <https://doi.org/10.3390/ijerph20095631>
- Braun, V., & Clarke, V. (2006). Using thematic analysis in psychology. *Qualitative Research in Psychology*, 3(2), 77–101. <https://doi.org/10.1191/1478088706qp0630a>
- Bryman, A. (2016). *Social research methods*. Oxford university press.
- Cali, B. E., Coleman, J. M., & Campbell, C. (2013). Stranger Danger? Women's Self-Protection Intent and the Continuing Stigma of Online Dating. *Cyberpsychology, Behavior, and Social Networking*, 16(12), 853–857. <https://doi.org/10.1089/cyber.2012.0512>
- Cantrell, M. A., & Lupinacci, P. (2007). Methodological issues in online data collection. *Journal of Advanced Nursing*, 60(5), 544–549. <https://doi.org/10.1111/j.1365-2648.2007.04448.x>
- Coghlan, E., & Kirwan, G. (2013). Investigating 'Need for Achievement' between goal-orientated and non-goal-orientated environments' (1st Edition).
- Comunello, F., Parisi, L., & Ieracitano, F. (2021). Negotiating gender scripts in mobile dating apps: between affordances, usage norms and practices. *Information, Communication & Society*, 24(8), 1140–1156. <https://doi.org/10.1080/1369118X.2020.1787485>
- Corbin, J. (1998). *Basics of Qualitative Research : Techniques and Procedures for Developing Grounded Theory*.

- Creswell, J. W., & Poth, C. N. (2016). *Qualitative inquiry and research design: Choosing among five approaches*. Sage publications.
- EarthWeb. (2023). HOW MANY RELATIONSHIPS START ONLINE IN 2023 | EarthWeb. <https://earthweb.com/how-many-relationships-start-online/>
- Ellison, N., Heino, R., & Gibbs, J. (2006). Managing Impressions Online: Self-Presentation Processes in the Online Dating Environment. *Journal of Computer-Mediated Communication*, 11(2), 415–441. <https://doi.org/10.1111/j.1083-6101.2006.00020.x>
- Evans, D. N., & Blount-Hill, K. L. (2022). Swipe Right?: Experimental Analyses of App-Based Dating in the Age of Criminal Stigma. *Corrections*, 7(4), 296–318. <https://doi.org/10.1080/23774657.2020.1799726>
- Fullwood, C., James, B. M., & Chen-Wilson, C.-H. (Josephine). (2016). Self-Concept Clarity and Online Self-Presentation in Adolescents. *Cyberpsychology, Behavior, and Social Networking*, 19(12), 716–720. <https://doi.org/10.1089/cyber.2015.0623>
- Gatter, K., & Hodkinson, K. (2016). On the differences between Tinder™ versus online dating agencies: Questioning a myth. An exploratory study. *Cogent Psychology*, 3(1), 1162414. <https://doi.org/10.1080/23311908.2016.1162414>
- Gibbs, J. L., Ellison, N. B., & Lai, C.-H. (2011). First Comes Love, Then Comes Google: An Investigation of Uncertainty Reduction Strategies and Self-Disclosure in Online Dating. *Communication Research*, 38(1), 70–100. <https://doi.org/10.1177/0093650210377091>
- Israel, M., & Iain, H. (2006). *Research ethics for social scientists*. Sage Publication.
- Kirwan, G. (2010). Cyberpsychology. *The Irish Journal of Psychology*, 31(1–2), 69–84. <https://doi.org/10.1080/03033910.2010.10446324>
- Lieberman, A., & Schroeder, J. (2020). Two social lives: How differences between online and offline interaction influence social outcomes. *Current Opinion in Psychology*, 31, 16–21. <https://doi.org/10.1016/j.copsyc.2019.06.022>
- Meredith, J. (2020). Conversation analysis, cyberpsychology and online interaction. *Social and Personality Psychology Compass*, 14(5), 285–294. <https://doi.org/10.1111/spc3.12529>
- Naji Bajnaid, A., & Elyas, T. (2017). Exploring the Phenomena of Online Dating Platforms Versus Saudi Traditional Spouse Courtship in the 21st Century. *Digest of Middle East Studies*, 26(1), 74–96. <https://doi.org/10.1111/dome.12104>
- Ranzini, G., & Lutz, C. (2017). Love at first swipe? Explaining Tinder self-presentation and motives. *Mobile Media & Communication*, 5(1), 80–101. <https://doi.org/10.1177/2050157916664559>
- Smith, D.-N. (2023). How Deception Plays a Role in Online Dating and Dating Apps. *Canadian Journal of Family and Youth / Le Journal Canadien de Famille et de La Jeunesse*, 15(2), 23–32. <https://doi.org/10.29173/cjfy29869>
- Statista. (2023). Online dating global market size 2023 | Statista. <https://www.statista.com/outlook/dmo/eservices/dating-services/online-dating/worldwide>
- Sumter, S. R., Vandenbosch, L., & Ligtenberg, L. (2017). Love me Tinder: Untangling emerging adults' motivations for using the dating application Tinder. *Telematics and Informatics*, 34(1), 67–78. <https://doi.org/10.1016/j.tele.2016.04.009>
- Timmermans, E., & De Caluwé, E. (2017). To Tinder or not to Tinder, that's the question: An individual differences perspective to Tinder use and motives. *Personality and Individual Differences*, 110, 74–79. <https://doi.org/10.1016/j.paid.2017.01.026>
- Toma, C. L., & Hancock, J. T. (2010). Looks and Lies: The Role of Physical Attractiveness in Online Dating Self-Presentation and Deception. *Communication Research*, 37(3), 335–351. <https://doi.org/10.1177/0093650209356437>
- Valkenburg, P. M., & Peter, J. (2007). Who Visits Online Dating Sites? Exploring Some Characteristics of Online Daters. *CyberPsychology & Behavior*, 10(6), 849–852. <https://doi.org/10.1089/cpb.2007.9941>
- Wiederhold, B. K. (2021). How COVID Has Changed Online Dating—And What Lies Ahead. *Cyberpsychology, Behavior, and Social Networking*, 24(7), 435–436. <https://doi.org/10.1089/cyber.2021.29219.editorial>

## Factors Influencing the Formation of False Health Information

Kevin K.W. Ho<sup>1,\*</sup>  
Shaoyu Ye<sup>2</sup>

\*Corresponding author

<sup>1</sup> University of Tsukuba – Institute of Business Sciences, Tokyo, Japan, ho.kevin.ge@u.tsukuba.ac.jp

<sup>2</sup> University of Tsukuba – Institute of Library, Information, and Media Studies, Ibaraki, Japan, shaoyu@slis.tsukuba.ac.jp

### ABSTRACT

The COVID-19 pandemic created uncertainty about our health and lives, and people were scared and looking for information to make themselves less likely to get infected. Yet, much information spread on the Internet may not be true. Before the pandemic, fake news, misinformation, and disinformation about public health (i.e., false health information) were found spreading on social media. Due to the citizens' lack of trust in their governments in many countries, people were more likely to believe in such false health information. This research proposed a conceptual model for understanding factors influencing false health information formation by reviewing recent literature on spreading fake news and misinformation about health information from health science and social science disciplines. We focused on understanding how it spread during and after the COVID-19 pandemic and how it affected people's perceptions of believing and not believing the information disseminated on social media by different stakeholders (i.e., government departments, public health authorities, etc.). Our findings provided a clear understanding of potential factors influencing the spreading of false health information and helped researchers and stakeholders understand how false health information spreads. It set the foundations for future research on this research area, including but not limited to studying factors making people believe in false information, factors making people alert to false information, and factors that strengthen or weaken those effects, and developing policy recommendations for how we can minimize the impact of false health information on our society and others.

*Keywords:* False health information, health fake news, health misinformation, privacy, and COVID-19.

### INTRODUCTION

We are walking through the COVID-19 pandemic together. It is probably one of the most severe pandemics since the notorious Spanish flu happened about 100 years ago. The COVID-19 pandemic not only created a public health crisis that affected not only our physical health but also our mental health (Ye & Ho, 2023; Ye *et al.*, 2023). Much effort has been put into researching the impact of COVID-19 on various issues in our society (Huang *et al.*, 2021, 2022, 2023). Rocha *et al.* (2023) also reported that the COVID-19 pandemic caused people to have psychological disorders, anxiety, etc. Most countries worldwide, if not all, had to take tight measures to avoid the spread of the COVID-19 virus, which included massive lockdowns, quarantines, travel restrictions, social distancing, and mandates of wearing masks, having vaccinations, and using contact tracing apps (Ho, Chan & Chiu, 2022; Ho, Chiu & Sayama, 2023). People who did not believe in vaccinations and various government health policies before the COVID-19 pandemic would not follow these government mandates and suggested that it was a conspiracy (Romer & Jamieson, 2020). Some people who used to believe in vaccinations and public health policy requirements also felt puzzled about why the COVID-19 virus could not be controlled and turned to believe in false health information spread on social media. As some people did not believe in the public health policy requirements, it made it more difficult for the public health authorities to contain the virus and slow its transmission, resulting in a more severe impact on our society. In this research, we reviewed papers on how false health information was formed and spread on social media before and during the COVID-19 Pandemic to understand factors affecting its creation and spreading and find ways to reduce its impact on our society in the future. Particularly, we would like to focus on the following three research questions (RQs):

RQ1: What are the factors that make people believe in false health information?

RQ2: What are the factors that make people generate false health information?

RQ3: What are the methods to reduce the impact of false health information?

We focus our review on research related to social media because it has been known to be the most influential media in spreading false health information in the model society (Bode & Vraga, 2017), and we hope this approach will provide us with an essential understanding of the situation.

### LITERATURE REVIEW

#### Research on False Health Information on Social Media Before COVID-19

Starting from Web 2.0, people can easily create and share user-generated information. Web 2.0 provides opportunities for developing interactive platforms for medical practitioners to share their knowledge and keep up to date with the latest medical science developments (Bougioukas *et al.*, 2020) and for patients and members of the public to share health information and provide social support to each other (Le, Hoang & Pham, 2023). However, it also provides a platform for people to generate and

spread false health information. From public health perspectives, alternative opinions and even wrong information can now be easily created and spread on the Web and attract people's eyeballs. Nowadays, the extent of false health information shared on social media is quite severe. For example, based on social media data collected from Poland between 2012 and 2017, Waszak, Kasprzycka-Waszak, and Kubanek (2018) suggested that about 40% of health information shared on social media was fake, relating to alternative medicine, disease denial (such as AIDS), and anti-vaccination. In addition, a study conducted in 2013 with participants from the United States by Oliver and Wood (2014) showed that about half of the participants believed in at least one of the medical conspiracy theories circulating on the Internet. This shows that false health information can be disseminated on social media, and many believe in it. In addition, Wang *et al.* (2019) conducted a systematic literature review on false health information research related to social media, with papers retrieved from major academic databases between January 2012 to November 2018. Of the 57 papers analyzed, 30 were related to misinformation about communicable diseases (such as HPV, MMR, flu, Zika virus, etc.) and vaccination. Others were related to misinformation about chronic non-communicable diseases (such as cancer, cardiovascular disease, etc.) and other topics, such as smoking, rumors on health issues, etc. They also reported that other scholars were investigating social media like Facebook, Twitter, and YouTube as the channels for spreading such false health information.

One of the predominant false health information on the Internet and social media is fueled by the anti-vaccination movement. Anti-vaccination activists use social media to engage with potential readers and spread their beliefs actively using tactics such as skewing the science or even presenting pseudoscience by arguing scientifically proven findings as incorrect and supporting non-proven anti-vaccine findings, continuously providing "new" theories and hypotheses to suggest that vaccines are useless and harmful, censoring information and arguments presented by others in their websites social media who were not supporting to their anti-vaccination arguments, and attacking people and organizations supporting vaccination (Kata, 2012). Believers in these extreme theories may usually reinforce their beliefs by reading the information presented by people alike and disbelieving in facts presented by others who do not believe in their ideas, becoming victims of the echo chamber effect and the hostile media effect (Ho, Chan & Chiu, 2022). Furthermore, some people who initially do not believe in anti-vaccination campaigns may be influenced by such information when seeking health information online to decide whether to be vaccinated and decide for themselves and their families not to take vaccines (Carrieri, Madio & Principe, 2019). This situation is problematic as it can lead to outbreaks of infectious diseases, such as measles, that have been under control for years (McKee & Middleton, 2019).

Indeed, many pieces of false health information are grounded in conspiracy theories. These include framing public authorities for covering the adverse effects of vaccines and pushing through governments' secret agendas. One typical example is the accusation that the MMR vaccine would cause autism, which has already been proved wrong but still circulated in the anti-vaccination community as an "example" of conspiracy (Destefano, 2007). Yet, this misinformation influenced the court decision in Italy, in which the Court of Rimini ruled in favor of a link between childhood vaccination and autism in 2012, and in 2015, the ruling was overturned by the Appeal Court in Bologna (Rizzi *et al.*, 2021). However, the ruling from the Court of Rimini had already caused the decline of Italy's vaccination rate in those years. This finding suggested that conspiracy theories, particularly those that once had "supporting evidence", would have a long-term effect on society even if they would have been proved wrong later. A more recent example before the COVID-19 pandemic is the Zika conspiracy theories, of which 20% of Americans believed in at least one of them, and is related to their conspiracy thinking level. Another example is the COVID-19 contact tracing apps mandate imposed by many countries, which conspiracy theory believers insisted is the tool governments wanted to use to surveil their citizens (Ho, Chiu & Sayama, 2023). Indeed, people with high levels of conspiracy thinking are more likely to accept such theories, and tailored publicity campaigns may be needed to target this group of people to rectify their misunderstanding (Klostad *et al.*, 2019).

In brief, even before the COVID-19 Pandemic, false health information has already been spreading on social media. It is fueled by conspiracy theories, particularly those proposing authorities cover the "true" facts of the "harm" of vaccination and other conspiracies for governments spreading "fake" diseases and using them as an excuse to impose more controls on society. Believers in such conspiracy theories and related campaigns are ready to twist the research findings to support their ideas and convince people to believe them. These actions can cause severe adverse effects, such as reducing vaccination rates and causing outbreaks of diseases that have been under control for a long time.

### **Research on False Health Information on Social Media During COVID-19**

Recent research findings of false health information show a more alarming situation. First, from a global perspective, people now have a low level of trust in their governments. Many people did not believe in various public health mandates for reducing the spread of the COVID-19 virus and would not like to follow them (Ho, Chiu & Sayama, 2023). Pertwee, Simas, and Larson (2022) argued that the COVID-19 pandemic further weakened people's trust in the public health authorities and fueled vaccine hesitancy. In addition, Pummerer *et al.* (2022) reported that people who believed in or were confronted with the COVID-19 conspiracy theory would have lower institutional trust, less support of government regulations related to COVID-19, less likely to adopt social distancing, and somehow reduced social engagement. Therefore, they even suggested that reporting false health information related to COVID-19 in the media (i.e., by telling people that it is false) would already reduce our efforts to fight the pandemic. Yet, a meta-analysis result reported by Walter *et al.* (2021) suggested that the corrective interventions would reduce the effect of false health information on people. Also, similar to the pre-pandemic situation, Romer and Jamieson (2020) also showed that conspiracy theories and vaccination misinformation influenced people's decisions to take preventive measures to protect themselves and be vaccinated during the beginning of the COVID-19 pandemic.

To look into the role of social media on false COVID-19 health information, Chipidza *et al.* (2022) used data collected from Twitter and Reddit between March 4 and 12, 2020, i.e., the beginning of the pandemic, as sources to conduct Latent Dirichlet Allocation (LDA) analysis on COVID-19-related social media news coverage topics. They showed that the topics found in these two social media included more topics than traditional media, such as newspapers and cable TV. Topics like misinformation on preventive measures and cures for COVID-19 could be found on such social media. Bin Naeem, Bhatti, and Khan (2020) also conducted a content analysis using a dataset of 1,225 fake news pieces published between January and April 2020. They showed that the three major types of COVID-19-related false health information published were (i) false claims, (ii) conspiracy theories, and (iii) pseudoscientific health therapies.

Furthermore, Melki *et al.* (2021) also used telephone interviews to collect responses from Lebanese at the beginning of the pandemic (between March 27 and April 23, 2020). They showed that people more likely to believe in false health information about COVID-19 were those who trusted social media news, interpersonal communication, and clerics. In addition, researchers also noted that people were more interested in viewing YouTube videos showing misinformation than videos with correct information presented by the public health authorities (Yeung *et al.*, 2022). Another research by Quinn, Fazel, and Peters (2021) used content analysis on 300 Instagram posts collected for ten days in April 2020. They noted that there was a general mistrust of authorities as people believed that they were covering up the “truth” of COVID-19, and there were a lot of posts related to conspiracy theories spreading on Instagram.

To sum up, with people having a low level of trust in their governments, the prolonged COVID-19 Pandemic further weakens their ties. It makes people more readily accept those false claims, conspiracy theories, and pseudoscientific arguments. As the most convenient tool for connecting people and receiving information during the pandemic (particularly for those with their towns locked down or under quarantine), social media has become the most efficient channel to spread both true and false health information. Yet, it is alarming that people would receive more interest in misinformation than true information. Therefore, public health authorities should find ways to reverse this situation.

## FINDINGS AND DISCUSSION

### RQ1: What are the Factors Making People Believe in False Health Information?

As mentioned, social media is the primary channel for circulating true and false health information online. Le *et al.* (2023) reported that people search for five significant types of health information online, including (i) sharing of personal health information, (ii) sharing health-related knowledge, (iii) general health messages, (iv) outcomes of health-related information sharing, and (v) findings of exploratory research in health. Yet, while such information is readily available, it is difficult for members of the public to understand it, as they do not have sufficient knowledge of medical sciences and statistics to understand the findings, and they may misunderstand the valid information and misinterpret the findings. Ho, Chan, and Chiu (2022) reported a case on Facebook showing that people misinterpreted the CDC’s report on the COVID-19 vaccination report and argued that taking vaccines would make people more easily infected by the COVID-19 virus. Indeed, the misinterpretation is caused by not taking the age group into calculating the infection rate. However, such misinterpretation would provide “evidence obtained from (re)interpreting from government reports” for supporting conspiracy theories.

Some people believe in false health information due to their beliefs in conspiracy theories, which they believe that governments are hiding information or having secret agendas (Destefano, 2007). This situation can reflect that trust in authority nowadays is low (Ho, Chiu & Sayama, 2023). Also, some false health information cases are related to politics. For example, it has been known that, in the U.S., the COVID-19 vaccination rate at the state level is related to political ideology, i.e., Republican States usually have a lower vaccination rate than Democrat States (Ho, Chan & Chiu, 2022), and further empirical findings to support the relationship between false health information and politics have also been reported by Romer and Jamieson (2020). Other health-related issues, such as women’s abortion rights, are also significantly influenced by political ideology (such as in the United States) (Chang *et al.*, 2023). Therefore, a person’s political background would be influential on whether a person would believe in false health information. This situation would increase false health information circulated in social media and further lower the trust in the authorities. Table 1 summarizes our initial findings related to RQ1.

Table 1: Factors making people believe in false health information.

Factors	Details	References
Lack of scientific and statistical background	Most people do not have sufficient knowledge to understand health information and will misunderstand the health information available on social media.	Ho, Chan, and Chiu (2022)
Believe in conspiracy theories and lack of trust in authorities	Some people believe in conspiracy theories and think governments and authorities hide the truth. This is also related to a low level of trust in authorities internationally.	Destefano (2007); Ho, Chiu, and Sayama (2023)
Follow their political party line	Political party supporters believe in (false) health information agreed by their political party line.	Chang <i>et al.</i> (2023); Ho, Chan, and Chiu (2022); Romer and Jamieson (2020).

Source: This study.

## RQ2: What are the Factors That Make People Generate False Health Information?

As social media content is user-generated, people may generate false health information in good faith as they think their alternative or incorrect information is correct. Their beliefs in the false health information may be the result of the echo chamber effect, i.e., they circulate their false health information among people with similar beliefs and thus reinforce their beliefs are the truth (Cinelli *et al.*, 2021) and/or the hostile media effect, i.e., they believe that media presenting opposite views are biased against them (Vallone, Ross & Lepper, 1985). Such actions can be the result of the following reasons. First, some people may act in good faith and believe that their misunderstanding of the health information is the correct representation, and generate false health information. In addition, believers of conspiracy theories would also generate and spread false health information grounded on those conspiracy theories they believed in to promote their ideas to others and to “help” other people. Also, some loyal supporters may generate false health information to fill the need for supporting the party line. In addition, there are reports that some countries may want to interfere in another country’s politics (i.e., further reduce citizens’ trust in another country) by spreading health misinformation by engaging people in social media and using bots (McKee & Middleton, 2019). Table 2 summarizes our findings related to RQ2.

Table 2: Factors making people generate false health information.

Factors	Details	References
Act in good faith	Some people generate false health information, intentionally and unintentionally, as they believe such alternative or incorrect views are correct. These people may misunderstand the correct information and misrepresent them. They can also be conspiracy theory believers or people supporting a political party that supports false health information, and they want to create “evidence” to support the false information and conspiracy theories they believe in.	Cinelli <i>et al.</i> (2021); Vallone, Ross, and Lepper (1985)
Foreign country influence	Prior studies show that some countries tried to use bots or Internet water armies to influence other countries’ political environments, such as helping a political party that is more friendly to them to gain political advantages.	McKee and Middleton (2019)

Source: This study.

## RQ3: What are the Methods to Reduce the Impact of False Health Information?

Some possible ways to reduce or even stop the impact of false health information in society are summarized in Table 3. First, we must acknowledge that removing false health misinformation is challenging, particularly those “supported” by “evidence”. An example of the claim of a causal relationship between childhood MMR vaccination and causing autism presented above shows that a court decision could be influenced by a retracted paper, which subsequently becomes further “evidence” to be claimed by conspiracy theory believers (Carrieri *et al.*, 2019). The more troublesome situation is even after the court ruling is overturned, conspiracy theory believers could still reuse it and twist the appeal ruling as another support for “authority intervention”. As a result, Cichocka (2020) suggested that we should be proactive in handling health misinformation as it would be more difficult to refute it and make people believe in the fact after it spreads. She suggested that “Prebunking” would be more helpful, i.e., to warn people about spreading false health information, probably through education on information literacy and analytical skills.

Furthermore, Vraga and Bode (2017) proposed using expert sources to correct false health information on social media through an online experiment on misinformation related to the Zika virus outbreak. They showed that corrective responses provided by public health authorities (in their case, CDC) would help to refute health misinformation. Also, Chipidza *et al.* (2022) suggested public health authorities use communication specialists to provide information in the early stage of the pandemic and use it to control/prevent the spread of false health information. Another practical approach currently adopted by social media is asking social media operators to take part in helping remove false health information from their platforms (McKee & Middleton, 2019; Mheidly & Fares, 2020).

While some countries now punishing people and companies for spreading false health information may help to deter people from spreading such information (Morgan 2018), Au *et al.* (2021) conducted a survey to check if people would be more eager to spread fake news if they got paid and reduce their intention to spread such news if there was legislation to punish them for spreading false health information. While they found that providing financial incentives would encourage people to spread the news online, no matter whether they believed the news was true or fake, they discovered that imposing legal punishment would deter people from sharing health news that they thought was true but encouraged them from sharing those they thought was fake. They argued that people might share false health information online, even when they would face punishment. It is because they wanted to show their rebellion or thought it was “too fake” and would be considered as sharing a joke with others and opined that they would not be punished (as they were spreading “jokes”, not “false information”). Yet, it is still possible to prevent the spreading of false health information.

Finally, some scholars suggested providing more education for people to improve their skills in identifying and recognizing false health information and stop tolerating pseudoscience health practices by highlighting the risks of believing in those practices (Bin Naem, Bhatti & Khan, 2020) on top of improving people’s level of media literacy (Melki *et al.*, 2021). This is, of course, a possible first and essential step that various governments can take immediately.



Table 3: Possible methods to reduce the false health information impact on society.

Methods	Details	References
Prebunking	As it would be more difficult to refute a conspiracy theory after it spreads, authorities should warn people about spreading false health information before it starts to spread.	Cichocka (2020)
Refuting by authority	It is possible that corrective responses provided by authorities, with the help of communication specialists, could help to refute false health information.	Chipidza <i>et al.</i> (2022); McKee and Middleton (2019); Mheidly and Fares (2020); Vraga and Bode (2017)
Legislation against the spreading of false health information	While some countries plan to implement legislation to deter people from spreading false information, its effect is questionable.	Au <i>et al.</i> (2021); Morgan (2018)
Education on media literacy	It is essential to provide more media literacy and false information identifying education in society to help citizens identify false health information and avoid spreading it.	Bin Naeem, Bhatti, and Khan (2020); Melki <i>et al.</i> (2021)

Source: This study.

**Resultant Research Model**

Our initial findings provide us with the foundations for conducting further research on why people believe in and generate false health information and finding possible ways to reduce the impact of false health information on society. Based on our initial findings, we developed a preliminary model as the foundation for further research, as presented in Figure 1. First, we identify the characteristics of people believing in false information, i.e., (i) lack of scientific and statistical background to understand health information, (ii) belief in conspiracy theories, and (iii) following their political line. These people may generate false health information in good faith. Also, foreign countries may want to gain political influence on the country concerned and generate false health information to influence them.

At the same time, we discovered methods that may help to reduce the spread of fake news, including (i) prebunking, (ii) refuting by authority with the help of communication specialists and social media platforms, (iii) legislation against the spreading of false health information, and (iv) education on media literacy. If we can use these methods correctly, we may have chances to reduce the impact of false health information on our society.

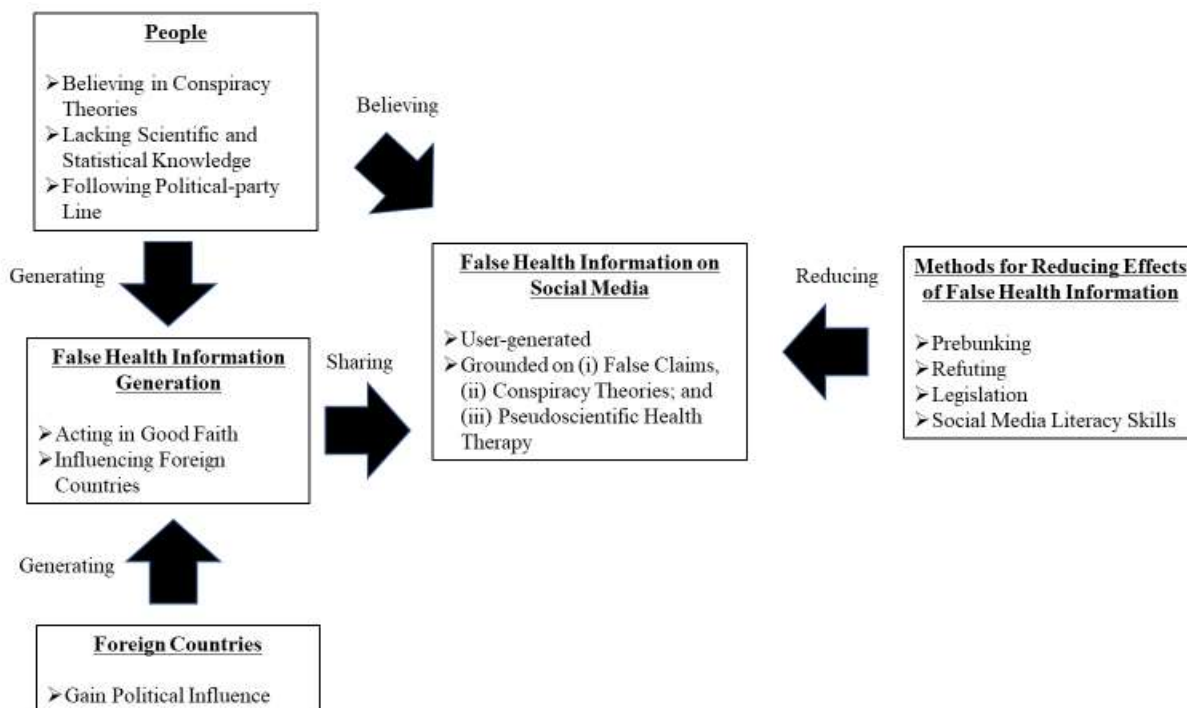

Source: This study.

Figure 1: Research model.

The next step of this research is to develop a qualitative study based on this preliminary model. Before we start our qualitative study, we also plan to further strengthen the model by conducting a further literature review, including the effect of sources of information and the level of trust and distrust and how these factors co-create (See-To & Ho, 2014) the social media environment concerning the formation, spreading, and stopping of false health information. Our qualitative study will ascertain further relevant

constructs on influencing people in generating false health information (such as people's trust and distrust in public health authorities, people's level of scientific and statistical knowledge, people's loyalty to a political party, and their level of beliefs in conspiracy theory would influence their possibility to generate false information) and strengthening their beliefs (such as the online information collecting behavior and whether the echo chamber effect and hostile media effect influence them). We will also investigate more methods for reducing the effects of false health information. The result of our qualitative study set the foundations for the final stage of our study for developing a quantitative study to validate the final conceptual model.

### CONCLUSION

We need all people to work together to reduce the spread of false health information in society. Indeed, many research studies in recent years have focused on studying how false information about health damages our society by making people disbelieve and distrust public health suggestions and policies. We hope this short review and the research model presented can provide insights into research and public health administrators for further developing new research to resolve the false health information problem for protecting our society.

### ACKNOWLEDGMENT

This work is supported by the JPSP KAKENHI Grant Number 23K11760 (PI: Prof. Kevin K.W. Ho) in Japan.

### REFERENCES

- Au, C. H., Ho, K. K. W., & Chiu, D. K. W. (2021). Stopping healthcare misinformation: The effect of financial incentives and legislation. *Health Policy*, 125(5), 627–633.
- Bode, L., & Vraga, E. K. (2017). See something, say something: Correction of global health misinformation on social media. *Health Communication*, 33(9), 1131–1140.
- Bougioukas, K. I., Bouras, E. C., Avgerinos, K. I., Dardavessis, T., & Haidich, A.-B. (2020). How to keep up to date with medical information using web-based resources: A systematized review and narrative synthesis. *Health Information and Libraries Journal*, 37(4), 254–292.
- Carrieri, V., Madio, L., & Principe, F. (2019). Vaccine hesitancy and (fake) news: Quasi-experimental evidence from Italy. *Health Economics Letter*, 28(11), 1377–1382.
- Chang, R.-C., Rao, A., Zhong, Q., Wojcieszak, M., & Lerman, K. (2023). #RoeOverturned: Twitter dataset on the abortion rights controversy. *Proceedings of the International AAAI Conference on Web and Social Media*, 17(1), 997–1005.
- Cinelli, M., De Francisci Morales, G., Galeazzi, A., Quattrociochi, W., & Starnini, M. (2021). The echo chamber effect on social media. *Proceedings of the National Academy of Science*, 118(9), Article e2023301118.
- Chipidza, W., Akbaripourdibazar, E., Gwanzura, T., & Gatto, N. (2022). Topic analysis of traditional and social media news coverage of the early COVID-19 pandemic and implications for public health communication. *Disaster Medicine and Public Health Preparedness*, 16(5), 1881–1888.
- Cichocka, A. (2020). To counter conspiracy theories, boost well-being. *Nature*, 587 (7833), 177.
- DeStefano, F. (2007). Vaccines and autism: Evidence does not support a causal association. *Vaccines*, 82(6), 756–759.
- Ho, K. K. W., Chan, J. Y., & Chiu, D. K. W. (2022). Fake news and misinformation during the pandemic: What we know, and what we don't know. *IT Professional*, 24(2), 19–24.
- Ho, K. K. W., Chiu, D. K. W., & Sayama, K. L. C. (2023). When privacy, distrust, and misinformation cause worry about using COVID-19 contact-tracing apps. *IEEE Internet Computing*, 27(2), 7–12.
- Huang, P. S., Paulino, Y. C., So, S., Chiu, D. K. W., & Ho, K. K. W. (2021). Editorial – COVID-19 pandemic and health informatics (Part 1). *Library Hi Tech*, 39(3), 693–695.
- Huang, P.-S., Paulino, Y.C., So, S., Chiu, D.K.W., & Ho, K.K.W. (2022). Guest editorial: COVID-19 pandemic and health informatics Part 2, *Library Hi Tech*, 40(2), 281–285.
- Huang, P.-S., Paulino, Y.C., So, S., Chiu, D.K.W. & Ho, K.K.W. (2023). Guest editorial: COVID-19 pandemic and health informatics Part 3, *Library Hi Tech*, 41(1), 1–6.
- Kata, A. (2012). Anti-vaccine activists, Web 2.0, and the postmodern paradigm – An overview of tactics and tropes used online by anti-vaccination movements. *Vaccine*, 30(25), 3778–3789.
- Klofstad, C. A., Uscinski, J. E., Connolly, J. M., & West, J. P. (2019). What drives people to believe in Zika conspiracy theories? *Humanities & Social Sciences Communications*, 5, Article 36.
- Le, L. H., Hoang, P. A., & Pham, H. C. (2023). Sharing health information across online platforms: A systematic review. *Health Communication*, 38(8), 1550–1562.
- McKee, M., & Middleton, J. (2019). Information wars: Tackling the threat from disinformation on vaccines. *The BMJ*, 365, Article 12144.
- Melki, J., Tamim, H., Hadid, D., Makki, M., El Amine, J., & Hitti, E. (2021). Mitigating infodemics: The relationship between news exposure and trust and belief in COVID-19 fake news and social media spreading. *PLoS ONE*, 16(6), Article e0252830.
- Mheidly N., & Fares, J. (2020). Leveraging media and health communication strategies to overcome the COVID-19 infodemic. *Journal of Public Health Policy*, 41, 410–420.
- Morgan, S. (2018). Fake news, disinformation, manipulation, and online tactics to undermine democracy. *Journal of Cyber Policy*, 3(1), 39–43.
- Naeem, S. B., Bhatti, R., & Khan, A. (2021). An exploration of how fake news is taking over social media and putting public health at risk. *Health Information and Libraries Journal*, 38(2), 143–149.

- Oliver, J. E., & Wood, T. (2014). Medical conspiracy theories and health behavior in the United States. *JAMA Internal Medicine*, 174(5), 817–818.
- Pertwee, D., Simas, C., Larso, H. J. (2022). An epidemic of uncertainty: Rumors, conspiracy theories and vaccine hesitancy. *Nature Medicine*, 28, 456–459.
- Pummerer, L., Böhm, R., Lilleholt, L., Winter, K., Zettler, I., & Sassenberg, K. (2022). Conspiracy theories and their societal effects during the COVID-19 pandemic. *Social Psychological and Personality Science*, 13(1), 49–59.
- Quinn, E. K., Fazel, S. S., & Peters, C. E. (2021). The Instagram infodemic: Conbranding on conspiracy theories, Coronavirus Disease 2019 and authority-questioning beliefs. *Cyberpsychology, Behavior, and Social Networking*, 24(8), 573–577.
- Rizzi, M., Attwell, K., Casigliani, V., Taylor, J., Quattrone, F., & Lopalco, P. (2021). Legitimising a ‘zombie idea’: Childhood vaccines and autism – the complex tale of two judgments on vaccine injury in Italy. *International Journal of Law in Context*, 17(4), 548–468.
- Rocha, Y. M., de Moura, G. A., Desidério, G. A., de Oliveira, C. H., Lourenço, F. D., & de Figueiredo Nicolete, L. D. (2023). The impact of fake news on social media and its influence on health during the COVID-19 pandemic: A systematic review. *Journal of Public Health*, 31, 1007–1016.
- Romer, D., & Jamieson, K. H. (2020). Conspiracy theories as barriers to controlling the spread of COVID-19 in the U.S. *Social Science & Medicine*, 263, Article 113356.
- See-To, E. W. K., & Ho, K. K. W. (2014). Value co-creation and purchase intention in social network sites: The role of electronic Word-of-Mouth and trust – A theoretical analysis. *Computers in Human Behavior*, 31, 182–189.
- Vallone, R. P., Ross, L., & Lepper, M. R. (1985). The hostile media phenomenon: Biased perception and perceptions of media bias in coverage of the Beirut massacre. *Journal of Personality and Social Psychology*, 49(3), 577–585.
- Vraga, E. K., & Bode, L. (2017). Using expert sources to correct health misinformation in social media. *Science Communication*, 39(5), 621–645.
- Walter, N., Brooks, J. J., Saucier, C. J., & Suresh, S. (2021). Evaluating the impact of attempts to correct health misinformation on social media: A meta-analysis. *Health Communication*, 36(13), 1776–1784.
- Wang, Y., McKee, M., Torbica, A., & Stuckler, D. (2019). Systematic literature review on the spread of health-related misinformation on social media. *Social Science & Medicine*, 240, Article 112552.
- Waszak, P. M., Kasprzycka-Waszak, W., & Kubanek, A. (2018). The spread of medical fake news in social media – The pilot quantitative study. *Health Policy and Technology*, 7(2), 115–118.
- Ye, S. Y., & Ho, K. K. W. (2023). College students’ Twitter usage and psychological well-being from the perspective of generalized trust: Comparing changes before and during the COVID-19 pandemic. *Library Hi Tech*, 41(1), 152–173.
- Ye, S. Y., Ho, K. K. W., Wakabayashi, K., & Kato, Y. (2023). Relationship between university students’ emotional expression on tweets and subjective well-being: Considering the effects of their self-presentation and online communication skills. *BMC Public Health*, 23, Article 594.
- Yeung, A. W. K., Tosevska, A., Klager, E., Eibensteiner, F., Tsagkaris, C., Parvanov, E. D., Nawaz, F. A., Völkl-Kernstock, S., Schaden, E., Kletecka-Pulker, M., Willschke, H., & Atanasov, A. G. (2022). Medical and health-related misinformation on social media: Bibliometric study of the scientific literature. *Journal of Medical Internet Research*, 24(1), Article e28152.

## Revealing Stablecoin Successes: Lessons from a Case Study on USDT

Wen Shuo Hsu <sup>1</sup>  
Cheuk Hang Au <sup>2,\*</sup>

\*Corresponding author

<sup>1</sup> Master Student, National Chung Cheng University, Chiayi, Taiwan, for406351@gmail.com

<sup>2</sup> Assistant Professor, National Chung Cheng University, Chiayi, Taiwan, allenau@ccu.edu.tw

### ABSTRACT

Stablecoins, a type of cryptocurrency tethered to real-world currencies, have garnered attention in the cryptocurrency sphere. Despite being designed for price stability, as seen in the 2022 UST case, this is not always guaranteed. To prevent such incidents, understanding the vital factors behind stablecoin's success is crucial. This article examines the case of USDT, a prominent stablecoin. Preliminary findings indicate several internal factors (Early-mover advantages, Price maintenance reserve, Recognition-seeking, Resilience gained through challenges and Choice of multiple blockchains) and external factors (Emergence of the cryptocurrency ecosystem, Regulatory constraints) that drive the success of stablecoin.

*Keywords:* Cryptocurrency, Stablecoin, USDT, Tether

### INTRODUCTION

Cryptocurrencies have gained popularity due to their advantages of cheaper, faster, and geographically independent transactions. Bitcoin alone had around 106 million owners and thousands of daily transactions in 2023 (Buybitcoinworldwide.com 2023). However, the volatile nature of cryptocurrencies hinders their mainstream adoption. To address this, some firms have introduced stablecoins, cryptocurrencies with value pegged to non-volatile assets like the US Dollar. Stablecoins have been integrated into various cryptocurrency services, such as exchanges and wallets (e.g., Bitcoin and Coinbase). Some researchers suggested stablecoins a safe haven for cryptocurrency investors. When the price of Bitcoin declines, the trading volume of Tether (a type of stablecoin) tends to increase, indicating that investors view it as a secure investment choice (Wei, 2018).

In contrast to the volatility seen in many cryptocurrencies, stablecoins are purposely designed to uphold a consistent value, but such stability is not always guaranteed. In May 2022, TerraUSD (UST), a stablecoin, experienced a dramatic crash in May 2022 with value dropped nearly to zero. Prior to its collapse, UST held the impressive rank of eighth place in the cryptocurrency market, with a market capitalization nearing 40 billion USD. Being categorized as an algorithmic stablecoin, UST diverged from other well-known stablecoins like USDC and USDT, as its value is entirely reliant on the utilization of their algorithm instead of real-world assets (Kereakes et al., 2019). Its unprecedented decoupling triggered a collapse in the blockchain ecosystem, resulting in billions of dollars in losses for investors. Despite investors' potential anticipation of cryptocurrency volatility, the crash of a stablecoin can still be a jarring surprise. Therefore, this underscores the importance of delving into successful instances of stablecoin issuance. Otherwise, similar failures are likely to be repeated, with more cryptocurrency owners suffering from large financial losses.

This paper documents an ongoing case study on USDT, a highly successful stablecoin whose value is pegged to that of US dollars. Currently, it possesses the highest level of market cap and volume among all stablecoins in the market. We hope that through an in-depth study on USDT, we may be more informed about factors that contribute to the successful issuance of stablecoin and thus arrive at both theoretical and practical implications. Accordingly, our research question is, "How do we develop successful stablecoin?"

### LITERATURE REVIEW ON CRYPTOCURRENCY AND STABLECOIN

Cryptocurrencies are digital or virtual currencies that use encryption technology to ensure security (Li and Whinston, 2020). The high volatility of Bitcoin and other cryptocurrencies significantly hinders their practicality as a medium of exchange despite their ability to facilitate fast and unchangeable transactions (Dyhrberg, 2016). As a solution, some crypto-businesses have introduced stablecoins, which are pegged to other fiat currencies or financial instruments. Common examples of stablecoins include Tether (USDT), USD Coin (USDC), True USD (TUSD), and Binance USD (BUSD), all pegged to the US Dollar (Wei, 2018; Thanh et al., 2022). Table 1 illustrates arguments related to stablecoins.

The advantages of stablecoins include price stability, reduced financial and investment risks, and the ability to quickly convert to/from more volatile cryptocurrencies. Some scholars suggest that stablecoins have the potential to replace fiat currencies and call for regulatory measures that consider these impacts and potentials. However, there have also been cases of value crashes or de-peg, such as TerraUSD (Nurbaev et al, 2023). On the other hand, there are successful cases such as USDT, currently the largest stablecoin by market capitalization. While stablecoins have been subject to initial research from various perspectives.

There is currently limited research on the issuance of stablecoins. Exploring this direction in research could help bridge the gaps in academic understanding or market investments regarding the issuance of stablecoins.

Table 1: Descriptions of stablecoin

Reference	Argument
Morgan J (2023)	Extreme value fluctuations of unstable cryptocurrencies prevent them from being used as reliable stores of value or mediums of exchange. This requires stable value over time for effective use as 'money'.
Mita et al (2019)	Stablecoins can be categorized into four types based on their backing (fiat, commodity, crypto, and non-collateralized). Among these, non-collateralized stablecoins show strong potential for adoption in Decentralized Payment Systems.
Sidorenko (2019)	Within the realm of cryptocurrency, a growing portion of funds is shifting towards stablecoins and other low-volatility options. This shift has the potential to mitigate the risks associated with frequent asset turnover for cryptocurrency investors.
Wei (2018)	When the price of Bitcoin falls, the trade volume of USDT arises. This indicates that stablecoins are being perceived as a safe haven for some cryptocurrency investors.
Moin et al (2020)	The functions of value storage, the standard of measurement, transaction medium, and value steadiness are essential for all currencies. Recognizing the price instability of many cryptocurrencies, certain crypto-businesses have introduced stablecoins, which stablecoins maintain a consistent value tied to a stable asset, addressing the volatility concern.
Ante et al (2021)	Stablecoins offer a valuable research subject due to their resemblance to conventional fiat currencies. They might even have the potential to supplant fiat currencies on cryptocurrency exchanges.
Lipton et al (2020)	Stablecoins can serve as a trading tool for swift conversion between volatile cryptocurrencies and more stable currency alternatives. This provides users with U.S. Dollar-like trading and settlement capabilities, bypassing the need for traditional fund transfer methods.
Hsu et al (2022)	For newcomers to the world of cryptocurrencies, adopting stablecoins may pose a higher initial hurdle, as it requires time to grasp their nature and utility. Cryptocurrency businesses and exchanges need to effectively convey stablecoin knowledge to enhance newcomers' understanding and willingness to use them.

### LITERATURE REVIEW ON CRYPTOCURRENCY AND STABLECOIN

FinTech refers to disruptive technologies in the financial sector, encompassing various innovative financial products and services like cryptocurrencies, mobile payments, P2P lending, and crowdfunding (Shim and Shin, 2016). The number of FinTech startups is rising, with increased investments and continuous development of new FinTech solutions (Lee & Teo, 2015). Integrating different technologies is essential for the seamless development of FinTech products, creating a delightful customer experience and driving their adoption (Buckley and Webster, 2016).

FinTech products and services may be classified into multiple types, depending on the typology established by different researchers. Some researchers have investigated deeper into different specific types of FinTech. For example, concerning cryptocurrency services, researchers have argued the importance of developing a wide range of service options to cater to the diverse needs of users (Au et al., 2022), while successful cryptocurrency exchange services can categorize their product and service options based on capital flows, such as deposits, wealth growth, and withdrawals. In P2P lending contexts, investors are more likely to borrow through P2P lending platforms if they prefer substantial, short-term, high-interest loans. Conversely, borrowers' adoption of P2P lending platforms is facilitated by reduced interest rates, improved quality, and speed (Milne and Parboteeah, 2016; Au et al. 2020). To develop a successful Neobank, factors like innovation, diversity, and sensitivity to compliance issues must be considered in product and service selection (Nurbaev et al., 2022).

But across different types of FinTech, the development of products emphasizes diversity and the establishment of an ecosystem to meet the comprehensive needs of users, often driven by firms' innovation. Product development should also consider building critical mass through mechanisms such as customer lock-in and standardization. Trust, social influence, security, speed, privacy, and users' perceived capabilities are significant drivers for FinTech product adoptions, as highlighted in previous FinTech and IS literature. While financial benefits play a crucial role in FinTech adoption, they are less discussed in non-FinTech IS adoption literature.

### RESEARCH METHOD

We employed a case study approach along with the methodology of netnography for our research. The case study method is an empirical research technique used to comprehend the relationships between events, both preceding and subsequent, and the subject of the case (Merriam, 1988). Furthermore, the phenomenon of cryptocurrencies is multidimensional, encompassing both

external and technical aspects, making the adoption of an objective research approach overly complex (Gable, 1994). Thus, the case study method has emerged as an appropriate approach to investigate such phenomena (Klein & Myers, 1999).

Netnography is a form of research that involves documenting cultures and communities that emerge from internet-based communications. It aids in uncovering deeper insights from experiences that were less addressed in earlier research (Kozinets, 2010; Langer & Beckman, 2005). These characteristics are relevant to the cryptocurrency phenomenon as its activities are predominantly conducted online. We selected USDT as our research subject due to its success reflected in its user base and the broad range of financial products and services developed based on USDT. We intend to collect data from various sources, such as the official website of USDT, news articles and cryptocurrency exchanges.

Data analysis is performed concurrently with data collection to take full advantage of the flexibility case research methods afford (Eisenhardt, 1989). A set of aggregate theoretical dimensions and second-order themes (Gioia et al., 2013) were first derived from the existing FinTech literature as the theoretical lens to guide our data collection. The data collected was then coded using a mix of open, axial, and selective coding (Strauss & Corbin, 1998). More specifically, open coding was used to identify new and validate existing theoretical dimensions (e.g., stablecoin and FinTech successes), while axial coding was used to identify new and validate existing, second-order themes that fall under those dimensions (e.g., characteristics of stablecoins). Selective coding was then used to distil our case evidence into a number of first-order categories, which were then assigned to the appropriate dimensions and themes (Pan & Tan, 2011). Visual mapping and narrative strategies were also used to help us make sense of the voluminous amount of data collected (Langley, 1999; Klein & Myers, 1999). The former involved documenting, for example, the key milestones and stages of USDT development. Visual maps shown during the data analysis were gradually converted and merged into our model shown in the preliminary findings. The latter, on the other hand, entailed creating a textual summary of the key events, activities, and decisions that led to different development outcomes. Iterations between data, analysis, and theory development will continue until theoretical saturation is reached (Eisenhardt, 1989). The study is currently ongoing, and the iterative process between data collection, analysis, and theory development will continue until the state of theoretical saturation is reached (Eisenhardt, 1989).

## PRELIMINARY FINDINGS



Figure 1: Theoretical model illustrating internal and external factors related to stablecoin success

Our preliminary findings suggested that there are baskets of factors (internal and external) that influence the issuance and success of stablecoins. (See Figure 1).

### Emergence of Cryptocurrency Ecosystem

2017 was a pivotal turning point for the cryptocurrency ecosystem, with cryptocurrencies' price and overall market valuation speculating. The substantial price increases of Bitcoin and other cryptocurrencies garnered widespread attention and interest from both the market and users. Numerous companies and individuals entered this emerging field with the hope of seizing opportunities and profits. This rapid growth trend led to a swift and profound transformation of the cryptocurrency ecosystem. Furthermore, this environment gave rise to a multitude of innovative cryptocurrency projects, leading to the emergence of various new virtual currencies.

Amidst this backdrop, several USD-denominated virtual currencies gradually gained prominence in cryptocurrency trading. This included USDT (or known as Tether initially). In addition to the value peg to the US Dollar, USDT also possesses various advantages of stablecoins, such as price stability and the ability to convert into more volatile cryptocurrencies quickly. Furthermore, due to Tether's integration with many blockchains, it offers enhanced transaction liquidity (further detailed below). Consequently, Tether gained wider popularity and recognition, which is also essential for other Fintech business successes (Buckley and Webster, 2016).

### Regulatory Constraints

In recent years, the regulation of cryptocurrencies has become a concern in various countries. Attitudes of governments varies across different countries, from complete restrictions (e.g. China) to open-and-embrace (e.g. El Salvador). In most other countries, cryptocurrency-related activities are not illegal, but cryptocurrencies are not recognized as value-carrying artefacts.

For instance, Hong Kong is one of the places with no ban on cryptocurrencies, and is where the issuer of Tether located. While the issuer is still required to comply with some regulations in money laundering and other aspects, they can still freely develop their business. Issuers' geographical locations are especially important for issuing stablecoins, given the local regulations are more sensitive to any businesses related to financed transactions. Upon being treated as illegal, the entire business will not work. Conversely, there are some grey areas for Tether to work and thus grow in Hong Kong.

### **Early-Mover Advantages**

Among the top ten stablecoins ranked by CoinMarketCap in terms of market cap and trading volume, USDT is the only token that existed prior to 2018. Due to its early issuance and active involvement, users have become accustomed to using USDT leading to a critical mass of users. In turn, many developers and merchants adopted USDT for payment purposes.

For crypto-exchanges, on the other hand, it will be required for them to list USDT as one of the exchange options. For smaller crypto-exchanges, when they have limited capabilities to list all cryptocurrencies, they can only list more popular one (i.e., USDT). This create a positive reinforcement loop for the popularity of USDT. As a result, USDT has successfully claimed the dominant position in the stablecoin market by leveraging its early-mover advantage.

### **Price Maintenance Reserve**

When a cryptocurrency is widely disseminated and adopted, its value changes can impact a huge amount of people. For stablecoin, their value is expected to peg to certain real-world assets. Many users adopt cryptocurrency as a safe haven of cryptocurrency investment (Wei, 2018). Any value changes may harm inventors' confidence significantly. To offer confidence to investors and to stabilize the price, reserve backup for price maintenance is required. These reserves typically comprise assets with low volatility and high liquidity, such as cash and other short-term deposits, ensuring the value stability and redeemability of stablecoin.

More specifically, the value of USDT is backed by reserves largely US dollars, ensuring that each issued USDT is pegged to an equivalent amount of US dollars. The reserves are not solely comprised of physical US dollar cash, but also US Treasury bonds. It also involved a shift from connected papers (which Tether initially held but was doubted for reserve purposes) to treasury bonds.

Moreover, Tether regularly publishes financial reports related to its reserves to demonstrate financial transparency and accountability. These proactive measures have contributed to mitigating scepticism and criticism surrounding Tether. In the introduction and development of stablecoins, ensuring the rationality and stability of reserves is of paramount importance to ensure their long-term sustainability and utility.

### **Recognition-Seeking**

Without external adoption, a stablecoin may remain confined within the cryptocurrency sphere. To address such limitations and promote the wider adoption, it is crucial for a stablecoin to gain acceptance by businesses outside the cryptocurrency world, so that the usability of the stablecoin may be enhanced. For USDT, given its large user base, some firms have started accepting USDT for payment purposes. Examples include travel website Travala.com, Pornhub and TIME magazine, both accepting USDT for payment through intermediaries such as nowpayments.io.

Tether has even engaged in collaborations with governments. In 2022, Tether partnered with the city of Lugano in Switzerland to organize the "Plan B" initiative, aimed at promoting the adoption of Bitcoin and stablecoins throughout the city for paying parking fees and taxes. The initiative's goal is to enable over 2,500 businesses to accept three cryptocurrencies, including Bitcoin and USDT, by the end of 2023.

### **Resilience Gained Through Challenges**

Despite ranked as a top stablecoin, USDT has experienced instances of decoupling, indicating a deviation from its initial 1:1 peg with the US dollar. In 2018, it once demonstrated deviations of approximately 3% in response to some incidents in the cryptocurrency world. However, the price of USDT could revert to its original peg shortly. This created a form of resilience for investors. As a result, USDT was trusted by investors even when there were further shocks in the cryptocurrency world.

For example, in response to the closure of FTX, the second-largest cryptocurrency exchange, in late 2022, USDT temporarily decoupled from its peg but quickly reverted to its original ratio. This was unlike some other less-adopted stablecoins, with value de-peg lasting longer. Tether also face market panic along with massive capital withdrawal requests. However, Tether was able to manage these requests and turned market panic into opportunities by demonstrating Tether' capacity, enhancing investor trust in Tether.

### **Choice of Multiple Blockchains**

Instead of establishing its own blockchain, Tether adopted those of other existing and popular cryptocurrencies such as Ethereum, Tron, EOS and Solana. Since Tether launched its native token on Ethereum and Tron, Tether's market value and transaction volume have increased significantly(Coinmarketcap.com). This may be due to faster transaction speed, compatibility with most user wallets/exchanges, and reduced transaction fees, all enabled by the technical strengths of the chosen blockchain. Last but



not least, when USDT is available on different chains, one can switch to another chain for trading USDT (possibly via crypto-exchanges) to accelerate the transactions. In turn, the trading volume of USDT can be fostered.

### DISCUSSION AND CONCLUSION

This paper presented an ongoing case of USDT which investigated the critical success factors of stablecoins. Our current preliminary work has identified several critical success factors. We have primarily divided these factors into two categories: external factors and internal factors. The external factors included the emergence of the cryptocurrency ecosystem and regulatory constraints, while the internal factors included (1) Early-mover advantages, (2) Price maintenance reserve, (3) Recognition-seeking, (4) resilience gained through challenges, and (5) Choice of multiple blockchain. For stablecoin issuers, whether already launched or not, these factors can guide their cryptocurrency initiatives. Furthermore, these arguments may also apply for other cryptocurrencies, if they would like to bootstrap and maintain some forms of price stabilities.

In the future, we will continue to collect data and analyze it to further expand and validate our findings. We will further develop our theoretical model by gathering and integrating additional data, followed by conducting in-depth analysis and comparing with existing literature. This will provide a more comprehensive understanding of the success and implications of stablecoins, not only to address the research questions at hand but also to serve as a starting point for further research on other stablecoins

### REFERENCES

- Au, C. H., Tan, B., & Sun, Y. (2020). Developing a P2P lending platform: stages, strategies and platform configurations. *Internet Research*, 30(4), 1229-1249.
- Au, C. H., Law, K. M., Chiu, D. K., & Ho, K. K. (2022). Investigating Mainstreaming Strategies of Hot Cryptocurrencies-wallet. <https://aisel.aisnet.org/acis2022/1/>
- Buckley, R. P., & Webster, S. (2016). FinTech in developing countries: charting new customer journeys. *Journal of Financial Transformation*, 44.
- Dyhrberg, A. H. (2016). Bitcoin, gold and the dollar—A GARCH volatility analysis. *Finance Research Letters*, 16, 85-92.
- Eisenhardt, K. M. (1989). Building theories from case study research. *Academy of management review*, 14(4), 532-550.
- Gable, G. G. (1994). Integrating case study and survey research methods: an example in information systems. *European journal of information systems*, 3, 112-126.
- Gioia, D. A., Corley, K. G., & Hamilton, A. L. (2013). Seeking qualitative rigor in inductive research: Notes on the Gioia methodology. *Organizational research methods*, 16(1), 15-31.
- Hsu, W. S., Au, C. H., & Shieh, P.-H. (2022). Can Stablecoins Foster Cryptocurrencies adoption? A Preliminary Study from the Push-Pull-Mooring Model Perspective. <https://aisel.aisnet.org/acis2022/37/>
- Klein, H. K., & Myers, M. D. (1999). A set of principles for conducting and evaluating interpretive field studies in information systems. *MIS Quarterly*, 23(1), 67-94.
- Kozinets, R. V. (2010). *Netnography: Doing ethnographic research online*. Sage publications.
- Kereiakes, E., Do Kwon, M. D. M., & Platias, N. (2019). Terra money: Stability and adoption. White Paper, Apr.
- Langer, R., & Beckman, S. C. (2005). Sensitive research topics: netnography revisited. *Qualitative market research: An international journal*, 8(2), 189-203.
- Langley, A. (1999). Strategies for theorizing from process data. *Academy of Management Review*, 24(4), 691-710
- Lee, D. K. C., & Teo, E. G. (2015). Emergence of FinTech and the LASIC Principles. *Journal of Financial Perspectives*, 3(3).
- Lee, S., Lee, J., & Lee, Y. (2023). Dissecting the Terra-LUNA crash: Evidence from the spillover effect and information flow. *Finance Research Letters*, 53.
- Li, X., & Whinston, A. B. (2020). Analyzing cryptocurrencies. *Information Systems Frontiers*, 22, 17-22.
- Lipton, A., Sardon, A., Schär, F., & Schüpbach, C. (2020). 11. Stablecoins, digital currency, and the future of money. *Building the New Economy*, 30.
- Merriam, S. B. (1988). *Case study research in education: A qualitative approach*. Jossey-Bass.
- Milne, A., & Parboteeah, P. (2016). The business models and economics of peer-to-peer lending.
- Mita, M., Ito, K., Ohsawa, S., & Tanaka, H. (2019, July). What is stablecoin?: A survey on price stabilization mechanisms for decentralized payment systems. In *2019 8th International Congress on Advanced Applied Informatics (IIAI-AAI)* (pp. 60-66). IEEE.
- Moin, A., Sekniqi, K., & Sirer, E. G. (2020). SoK: A classification framework for stablecoin designs. *Financial Cryptography and Data Security: 24th International Conference, FC 2020, Kota Kinabalu, Malaysia, February 10–14, 2020 Revised Selected Papers 24*.
- Morgan, J. (2023). Systemic stablecoin and the brave new world of digital money. *Cambridge Journal of Economics*, 47(1), 215-260.
- Nurbaev, V., Au, C. H., & Chou, C.-Y. (2022). Exploring the Critical Success Factors of Different Types of FinTech: A Beginning Case of Neobank. <https://aisel.aisnet.org/cgi/viewcontent.cgi?article=1003&context=digit2022>
- O'Donohoe, S. (2010). Netnography: Doing ethnographic research online. In: *Taylor & Francis*.
- Osipovich, A., & Ostroff, C. (2022). Crash of TerraUSD Shakes Crypto. 'There Was a Run on the Bank.'. *Wall Street Journal* (May 12, 2022). <https://www.wsj.com/articles/crash-of-terrausd-shakes-crypto-there-was-a-runon-the-bank-11652371839>.

- Shim, Y., & Shin, D.-H. (2016). Analyzing China's fintech industry from the perspective of actor-network theory. *Telecommunications Policy*, 40(2-3), 168-181.
- Sidorenko, E. L. (2020). Stablecoin as a new financial instrument. In *Digital Age: Chances, Challenges and Future 7* (pp. 630-638). Springer International Publishing.
- Strauss, A., & Corbin, J. (1998). Basics of qualitative research: Techniques and procedures for developing grounded theory, 2nd ed. Sage Publications, Inc
- Thanh, B. N., Hong, T. N. V., Pham, H., Cong, T. N., & Anh, T. P. T. (2022). Are the stabilities of stablecoins connected? *Journal of Industrial and Business Economics*, 1-11.
- Uhlig, H. (2022). *A luna-tic stablecoin crash* (No. w30256). National Bureau of Economic Research.
- Nurbaev, V., Au, C. H., & Chou, C.-Y. (2023). When Stablecoin is No Longer Stable - A Case Study on the Failure of TerraUSD. International Conferences on Information Systems 2023, Hyderabad, India, December 10-13, 2023
- Wei, W. C. (2018). The impact of Tether grants on Bitcoin. *Economics Letters*, 171, 19-22.

## Robot Umpire vs. Human Umpire: The Spectators' Perception of Algorithm Errors in Baseball Games

Sunyoung Choi <sup>1</sup>  
Jooyoung Kim <sup>2</sup>  
Donghwan Kwon <sup>3</sup>  
Gimok Yun <sup>4</sup>  
Hangjung Zo <sup>5,\*</sup>

\*Corresponding author

<sup>1</sup> Ph.D. Student, Korea Advanced Institute of Science and Technology, South Korea, sunyung97@kaist.ac.kr

<sup>2</sup> Ph.D. Student, Korea Advanced Institute of Science and Technology, South Korea, jyk1095@kaist.ac.kr

<sup>3</sup> Master Student, Korea Advanced Institute of Science and Technology, South Korea, dh\_kwon@kaist.ac.kr

<sup>4</sup> Master Student, Korea Advanced Institute of Science and Technology, South Korea, ygm5239@kaist.ac.kr

<sup>5</sup> Professor, Korea Advanced Institute of Science and Technology, South Korea, joezo@kaist.edu

### ABSTRACT

Advancements in technology have allowed for robot umpires in baseball, replacing human umpires to minimize errors in judgment: strike/ ball decision. Yet, when watching games with robot umpires in pilot operations, there are some instances where the robot umpire also commits erroneous calls. Hence, this study would conduct a scenario-based online experiment to investigate how spectators perceive robot umpires in baseball games depending on the subject of error (robot umpire vs. human umpire). The experimental results would indicate that people demonstrate a lower degree of trust, attitude, and call credibility on robot umpires. Furthermore, the effects of robot umpires would be moderated by the familiarity of the robot umpire and by the phase of error (early vs. late in the game). These findings would contribute to the understanding of the spectator's perception of new technologies replacing humans and have practical implications for sports industry practitioners.

*Keywords:* Baseball, Robot umpire, Algorithm error, Serial position effect, Familiarity.

### INTRODUCTION

In an effort to minimize errors in judgment, sports are increasingly embracing new technologies. Sports officials are charged with the important responsibility of accurately and fairly overseeing high-level sports competitions (Mascarenhas, Collins, & Mortimer, 2005). However, the decisions of umpiring may be impacted by various contextual dimensions, such as crowd noise, home advantage, a team's aggressive reputation, or physical appearance (Jones, Paul, & Erskine, 2002; Nevill, Balmer, & Williams, 2002; Unkelbach & Memmert, 2010; Van Quaquebeke & Giessner, 2010).

The baseball league has been testing robot umpires, starting with the lower leagues, to replace human umpires who make incorrect judgments in strike/ball decision. In the year 2019, the Atlantic League in the United States became the first to implement the usage of robot umpires, employing a trackman system to make ball/strike decisions. Additionally, the Triple-A league in the United States plans to implement two distinct types of robot umpires during the 2023 season. One of half the games will feature all calls made by a robot umpire, while the other half will utilize a challenge system, enabling teams to challenge up to three calls per game. Following these lower leagues' pilot operation, Major League Baseball (MLB) officially announced the plan to adopt robot umpires in calling balls and strikes in 2024.

A robot umpire is one of the algorithms defined as "a set of encoded instructions for converting input data into a desired output based on predetermined calculations (Gillespie, 2014, p. 1)". According to the phenomena referred to as 'algorithm aversion', people frequently refuse and criticize algorithms despite the fact algorithms outperform human decision-making (Castelo, Bos, & Lehmann, 2019; Dietvorst, Simmons, & Massey, C., 2015; Jussupow, Benbasat, & Heinzl, 2020; Longoni, Bonezzi, & Morewedge, 2019). In contrast, algorithm appreciation, as demonstrated in computer science research, refers to the participants showing more agreement with participants showing more agreement with the same argument when it is presented as coming from an "expert system" rather than a "human" (Dijkstra, Liebrand, & Timminga, 1998).

Thus, this article aims to provide further insights into resolving conflicting results within the realm of baseball. Furthermore, the purpose of the article is to direct attention towards the perception of algorithm error (vs. human error), rather than solely engaging in comparisons between algorithms and human performance. Therefore, this research would examine how spectators perceive umpires in baseball games depending on the subject of an error: robot umpire's error vs. human umpire's error. The evaluations of umpires would be measured by trust, fairness, and other behavioral outcomes.

Another interesting inquiry is how people perceive a robot umpire's error (vs. a human error) according to the phase of error. According to the serial position effect, an umpire's error occurring early in the decision-making process (primacy effect) would have a greater negative impact than the error that occurs later (recency effect) (Manzey, Reichenbach, & Onnasch, 2012). Therefore, this research is planning to conduct 2 (algorithm error, human error) x 2 (early phase, late phase of error occurrence) between-subjects design on an online survey platform.

In addition, this research would explore the influence of familiarity with robot umpires on the evaluation of robot umpires. Familiarity is referred to as an individual's exposure to an algorithm carrying out a certain activity (Castelo, Bos, & Lehmann, 2019). Hence, this research expects the evaluation of robot umpires would be moderated by familiarity with robot umpires.

This research would make theoretical and practical contributions. First, this study would extend both sports and Human-Robot Interaction literature by analyzing how baseball spectators perceive robot umpires from a new perspective through algorithmic error. Second, this finding would also suggest that the managers of sports officials understand how to ensure that spectators' perceptions are positive as the sports industry introduces new technologies to replace humans.

## LITERATURE REVIEW

### The Introduction of Robot Umpire in Baseball

An umpire is essential because they enforce the rules of the game by deciding on match play in accordance with the rules of the sport. In baseball, an umpire's primary role is to determine whether a pitch thrown by a pitcher is in or out of the strike zone; According to MLB, the official strike zone is defined as the area over home plate between the midpoint of a batter's shoulders and the top of the uniform pants, when the batter is in his stance and ready to swing at a pitched ball, and a point just below the kneecap. However, there are frequent erroneous calls made by human umpires when determining whether the pitch is a strike or a ball. In the 2018 season, for instance, an average of 14 incorrect calls was made by human umpires per game (Hille, 2019).

Sports officials have a vital duty to impartially and accurately supervise elite sporting competitions (Mascarenhas, Collins, & Mortimer, 2005). Therefore, sports are progressively utilizing new technology in an effort to reduce human error in judgment. For example, Hawk-Eye was unveiled in 2001 as the first decision-aid technology; It was a complex ball trajectory system that was mostly used in cricket and tennis to assist umpires in making decisions. Likewise, baseball is set to adopt robot umpires in the 2024 season for strike/ball determination to minimize errors in judgment.

### Algorithm Aversion and Algorithm Appreciation

An algorithm is defined as "a set of encoded instructions for converting input data into a desired output based on predetermined calculations (Gillespie, 2014, p. 1)". As technology evolves, the constraints of human judgment and decision-making may be "cognitively treated" by algorithms (Burton et al., 2020). In other words, algorithms are being utilized to complement or replace people in many industries including sports. Despite the fact that algorithms frequently exceed human decision-making, people frequently oppose and criticize algorithms (Castelo, Bos, & Lehmann, 2019; Dietvorst, Simmons, & Massey, 2015; Jussupow, Benbasat, & Heinzl, 2020; Longoni, Bonezzi, & Morewedge, 2019). Dietvorst, Simmons, and Massey (2015) refer to this phenomenon as algorithm aversion.

While the majority of empirical data shows algorithm aversion, some research has discovered an appreciation for algorithmic guidance or even an excessive dependence on AI-based solutions (Dijkstra, Liebrand, & Timminga, 1998; Dijkstra, 1999; Logg, Minson, & Moore, 2019; Wagner, Borenstein, & Howard, 2018). For example, algorithmic financial advice tends to receive greater attention from individuals compared to crowdsourced advice, as it is generally preferred by people (Gunaratne, Zalmanson, & Nov, 2018). Depending on the nature of the task in which the algorithm is used, people may show an algorithm aversion or an algorithm appreciation. Therefore, the purpose of this article is to contribute to untangling these contradictory findings in the context of baseball games.

## HYPOTHESES DEVELOPMENT

Although the introduction of robot umpires in the sports industry has been mentioned due to human error, the robot umpires themselves also demonstrate instances of making mistakes during the trial operation. Error in decision-making refers to making a judgment that ultimately proves to be less accurate than intended, which is typical for judgments made in unclear situations. According to Dietvorst, Simmons, and Massey (2015), people are less forgiving of erring algorithms than they are of erring humans because they ignore the notion that algorithms might improve and learn from their flaws. Therefore, if people identify an algorithm's error, their reliability of the algorithm's advice tends to diminish. This phenomenon may be attributed to the presence of unfulfilled performance expectations (Dzindolet et al. 2002; Prah and Van Swol 2017). Therefore, this research proposes how people perceive a robot umpire's error (vs. human error) in the context of calling strike/ball decisions in a baseball game. Hence, this research hypothesizes the following.

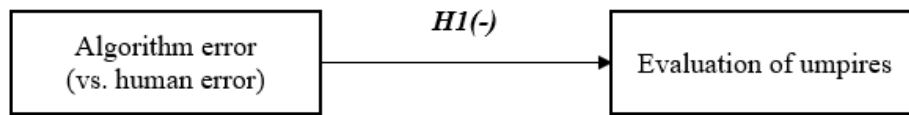

Figure 1: A research model of the negative effect of algorithm error on the evaluation of umpires (H1)

**Hypothesis 1. Spectators would evaluate robot umpires more negatively compared to human umpires when they saw a robot umpire's error (vs. human error)**

Serial position effect is commonly identified as an individual recall pattern: Items shown first or last in a sequence have a recall advantage over items provided in the middle, which is known as a primacy or recency effect, respectively (Glanzer & Cunitz, 1966; Murdock, 1962); Furthermore, the primacy effect is stronger than the recency effect (Worchel et al., 1988). The identification of the decision-making stage upon the discovery of an algorithmic error is imperative due to its evident significance. Hence, the degree of algorithm aversion differs based on whether the error happens early or late in the decision-making process. As a result, an algorithmic error occurring early in the decision-making process (primacy effect) has a greater negative impact than the error that occurs later (recency effect) (Manzey, Reichenbach, & Onnasch, 2012). This study would display a robot umpire's error (vs. a human umpire's error) in the second and eighth innings of a baseball game. The aim of this study is to investigate the influence of the error phase on algorithm aversion, concerning errors made by either a robot umpire or a human umpire. Specifically, this study seeks to determine how the extent of algorithm aversion is impacted by the phase of the error (early vs late). Therefore, this research proposes the following.

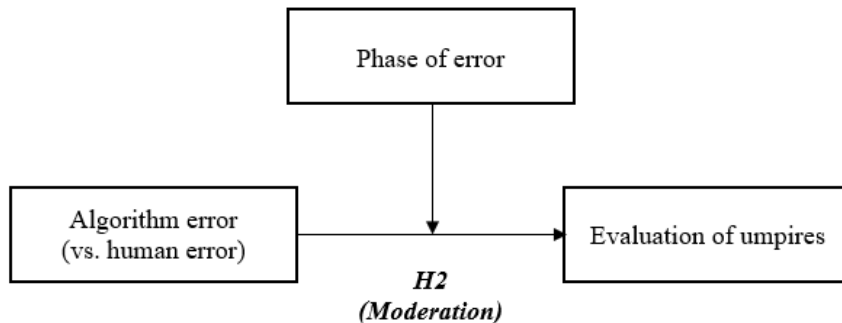

Figure 2: A research model of the moderating effect of the phase of an error (H2)

**Hypothesis 2. The effect of the type of umpire error on spectators' evaluation of an umpire would be more negative when they see an umpire error in the early phase of a baseball game**

Familiarity refers to individuals' exposure to an algorithm carrying out a certain activity (Castelo, Bos, & Lehmann, 2019). Previous psychological research (e.g. Monin, 2003) has found strong evidence for the beneficial relationship between familiarity and one's emotional reactions to an object since it fosters pleasant emotions toward the object (Garcia-Marques, 2000; Patterson and Mattila, 2008). According to previous research, people who have received training in statistical methods and algorithms are more likely to employ them (Araujo et al., 2020; Önkal, Gönül, & De Baets, 2019). Additionally, algorithm aversion can also be lessened via practical algorithm practice in simulated contexts (Li, Rau, & Huang, 2020). Existing literature has demonstrated that such familiarity will ultimately result in one's favorable attitude since humans frequently judge based on their affection (Monin, 2003; Patterson and Mattila, 2008). Therefore, this research aims to investigate the applicability of the aforementioned findings within the context of a baseball game, even if the robot umpire commits errors. Hence, this study hypothesizes the following.

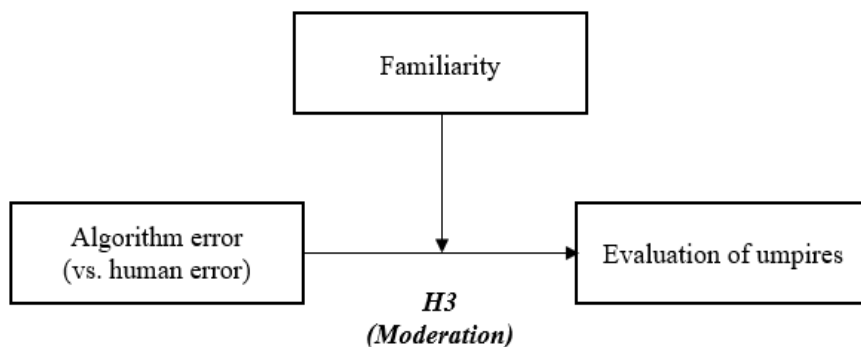

Figure 3: A research model of the moderating effect of familiarity (H3)

**Hypothesis 3. The effect of the type of umpire error on spectators' evaluation of an umpire would be lessened by the familiarity of robot umpire**

## METHODS

### Participants & Procedure

A total of 200 participants would be recruited from the survey platform. In this study, both the scenarios and the survey questions are written in English. Therefore, the participant pool would be restricted to participants in the United States whose first language is English. Firstly, the participants read the basic information about baseball and the process of strike and ball determination executed by an umpire. They also read a scenario in which a robot umpire or a human umpire makes an on-field error in a strike/ball call. After that, participants would be asked about their evaluation of the robot umpire (vs. human umpire) by using these factors: fairness, trust, attitude, call credibility, and expertise. Finally, they would answer questions about the baseball viewing experience and demographic questions. To prevent their inattention and improve the validity of response, Catcha and one attention check question would be included in the experiment material (Aguinis, Villamor, & Ramani, 2021).

The participants would be randomly assigned to a 2 x 2 between-subject design. The first two-level factor is a subject of an on-field error in a strike/ball call. Half of the participants would be assigned to a match where a robot umpire makes an error in a call. The other half of the participants would be assigned to a match where a human umpire makes an error in a call.

The second two-level factor is the phase of error occurrence: early phase vs. late phase. Half of the participants would read a scenario about a game in which the robot umpire (or human umpire) makes an error in a call early in the game. There are nine regular innings in a baseball game and it is divided into 3 innings. The early phase of a game would be set as the 2nd inning, which is the middle of the 1st and 3rd innings. The other half of the participants would read a scenario about a game in which the robot umpire (or a human umpire) makes an error in a call late in the game.

### Measures

This study would use fairness, trust, attitude, call credibility, and expertise as the evaluation of an umpire in a baseball game. This research would measure fairness (Waddell, 2018), trust (Johnson and Grayson's research, 2005), call credibility (Roberts, 2010), and expertise (Ohanian, 1990) using four-item scale (1= "strongly disagree", 7 = "strongly agree"). This research would measure the attitude toward using an umpire randomly assigned to each participant (Heerink et al., 2010) using three-item scale (1= "strongly disagree", 7 = "strongly agree"). In this study, familiarity would be employed as a moderator variable. Specifically, the degree of familiarity that participants had with a robot umpire in the context of baseball would be assessed using a three-item scale (1= "strongly disagree", 7 = "strongly agree"). The measurement items are shown in Table 1.

Variable name	Items
<b><i>Fairness</i></b>	
Fairness1	If the umpire makes the call, then the call was done unbiased
Fairness2	If the umpire makes the call, the call was error-free
Fairness3	If the umpire makes the call, then the call was done accurately
Fairness4	If the umpire makes the call, then the call was done objectively
<b><i>Trust</i></b>	
Trust1	I trust the umpire
Trust2	I can rely on the umpire
Trust3	I have no doubt about the umpire
Trust4	I don't need to be cautious about the umpire
<b><i>Attitude</i></b>	
Attitude1	I think it is good to use an umpire to determine a strike/ball in baseball
Attitude2	The use of an umpire is beneficial for the judgment of a strike/ball
Attitude3	In my opinion, the use of an umpire in baseball will have a positive impact
<b><i>Call credibility</i></b>	
Call credibility1	The umpire's call is accurate
Call credibility2	The umpire's call is believable
Call credibility3	The umpire's call is fair
Call credibility4	The umpire's call is trustworthy
<b><i>Expertise</i></b>	
Expertise1	The umpire's call is expert
Expertise2	The umpire's call is knowledgeable
Expertise3	The umpire's call is qualified
Expertise4	The umpire's call is skilled
<b><i>Familiarity</i></b>	
Familiarity1	I am familiar with the concept of a robot umpire in baseball
Familiarity 2	I am familiar with the actions and decisions of a human umpire in person
Familiarity 3	I am familiar with the use of technology in baseball umpiring, such as automated strike zones

Table1: Measurement items of evaluation of umpire and familiarity

## EXPECTED OUTCOME

In order to evaluate hypothesis 1, this research would conduct an analysis using t-test methodology. The expected results of the analysis would indicate that trust in umpires, attitude, call credibility, expertise, and fairness would be different depending on the agent of error. For each measurement, the t-test would indicate that the evaluation of the robot umpire will be more negative than the human umpire.

Additionally, in order to evaluate hypothesis 2, Hayes's PROCESS macro (Model 1) would be used to test the moderating effects of the phase of the error. The moderating effect of the phase of error would be significant for all measurement factors: trust, attitude, call credibility, expertise, and fairness. Furthermore, Hayes's PROCESS macro (Model 1) was employed to test the moderating effects of familiarity with the robot umpire (Hypothesis 3). The results of the analysis would indicate that trust, attitude, call credibility, expertise, and fairness would be significantly moderated by the familiarity of the robot umpire.

Additionally, this research would use Johnson-Neyman (J-N) technique (Johnson & Fay, 1950; Johnson & Neyman, 1936; Potthof, 1964) to investigate significant interactions. In contrast to the pick-a-point method, Johnson-Neyman (J-N) technique has been used to compute a "region of significance" for the simple slope of a focused predictor based on the value of the continuous moderator. After identifying the moderating effect on each measurement, this research would examine the effect of algorithmic error \* the phase of the error and the effect of algorithmic error \* Familiarity on each dependent variable: trust, attitude, call credibility, and expertise by a moderator.

### EXPECTED DISCUSSION

Although research on algorithm aversion was extensively tested in various domains, there exists a dearth of studies examining this phenomenon in the context of the sports industry. The findings of the research would reveal the presence of algorithm aversion in robot umpires in baseball games. Despite the errors of judgment, participants would perceive higher levels of trust, attitude, call credibility, and expertise in human umpires. Moreover, participants would maintain a positive attitude toward the utilization of human umpires rather than robot umpires in the context of baseball games. These expected outcomes would highlight the significance of considering algorithm aversion and its implication for the introduction of new technologies, such as robot umpires, into the sports industry. Furthermore, the findings of this study would hold potential implications for decisionmakers involved in the consideration of robot umpires as a replacement for human umpires in the realm of baseball.

Moreover, this study is planning to explore whether spectators' algorithm aversion toward robot umpires is influenced by the phase of error during a baseball game. Hence, this research would investigate the relative impact of the primary effect compared to the recency effect based on the serial position effect. Additionally, this paper would examine whether familiarity with robot umpires influences the level of algorithm aversion. The expected results would demonstrate a significant effect on factors such as trust, attitude, call credibility, expertise, and fairness. If familiarity with a robot umpire is employed as a moderator to reduce algorithm aversion for a robot umpire, the findings would emphasize the significance of familiarity to the spectators' perception of the robot umpire. As the implementation of robot umpires is planned for 2024 in the MLB league, it would be imperative for baseball league authorities to continue educating their audience about these technological innovations.

Ultimately, this research would be critical for enhancing spectators' perceptions of the introduction of new technologies. And for this to happen, sports industry stakeholders would need to proactively engage in effective promotion well in advance of introducing these new technologies, thereby facilitating a process of demystification. Hence, the result of this research would contribute to fostering a favorable reception and understanding among spectators.

### ACKNOWLEDGMENT

This research was supported by the MSIT (Ministry of Science and ICT), Republic of Korea, under the ITRC (Information Technology Research Center), Republic of Korea, support program (IITP-2020-0-01787) supervised by the IITP (Institute of Information & Communications Technology Planning & Evaluation), Republic of Korea.

### REFERENCES

- Aguinis, H., Villamor, I., & Ramani, R. S. (2021). MTurk research: Review and recommendations. *Journal of Management*, 47(4), 823-837. <https://doi.org/10.1177/0149206320969787>
- Araujo, T., Helberger, N., Kruijemeier, S., & De Vreese, C. H. (2020). In AI we trust? Perceptions about automated decision-making by artificial intelligence. *AI & Society*, 35, 611-623. <https://doi.org/10.1007/s00146-019-00931-w>
- Burton, J. W., Stein, M. K., & Jensen, T. B. (2020). A systematic review of algorithm aversion in augmented decision making. *Journal of Behavioral Decision Making*, 33(2), 220-239. <https://doi.org/10.1002/bdm.2155>
- Castelo, N., Bos, M. W., & Lehmann, D. R. (2019). Task-dependent algorithm aversion. *Journal of Marketing Research*, 56(5), 809-825. <https://doi.org/10.1177/0022243719851788>
- Dietvorst, B. J., Simmons, J. P., & Massey, C. (2015). Algorithm aversion: People erroneously avoid algorithms after seeing them err. *Journal of Experimental Psychology: General*, 144(1), 114. <https://doi.org/10.1037/xge0000033>
- Dijkstra, J. J. (1999). User agreement with incorrect expert system advice. *Behaviour & Information Technology*, 18(6), 399-411. <https://doi.org/10.1080/014492999118832>
- Dijkstra, J. J., Liebrand, W. B., & Timminga, E. (1998). Persuasiveness of expert systems. *Behaviour & Information Technology*, 17(3), 155-163. <https://doi.org/10.1080/014492998119526>
- Dzindolet MT, Pierce LG, Beck HP, Dawe LA (2002) The perceived utility of human and automated aids in a visual detection task. *Human Factors*, 44(1), 79-94. <https://doi.org/10.1518/0018720024494856>



- Garcia-Marques, T. (2000). The Positive Feeling of Familiarity: Mood as an Information Processing Regulation mechanism. In *The message within: The role of subjective experience in social cognition and behavior* (pp. 240). Psychology Press, Philadelphia.
- Gillespie, T. (2014). The relevance of algorithms. *Media Technologies: Essays on Communication, Materiality, and Society*, 167(2014), 167. <https://doi.org/10.7551/mitpress/9780262525374.003.0009>
- Glanzer, M., & Cunitz, A. R. (1966). Two storage mechanisms in free recall. *Journal of Verbal Learning and Verbal Behavior*, 5(4), 351-360. [https://doi.org/10.1016/S0022-5371\(66\)80044-0](https://doi.org/10.1016/S0022-5371(66)80044-0)
- Gunaratne, J., Zalmanson, L., & Nov, O. (2018). The persuasive power of algorithmic and crowdsourced advice. *Journal of Management Information Systems*, 35(4), 1092-1120. <https://doi.org/10.1080/07421222.2018.1523534>
- Heerink M, Kröse B, Evers V, Wielinga B (2010) Assessing acceptance of assistive social agent technology by older adults: the Almere model. *International Journal of Social Robotics*. doi:10.1007/s12369-010-0068-5
- Hille, B. (2019). MLB umpires missed 34,294 ball-strike calls in 2019, study shows. Retrieved from: <https://www.sportingnews.com/us/mlb/news/mlb-umpires-missed-34294-ball-strike-calls-2018-studyshows/ieco5qe5611j1w2cmv3accu5w>
- Johnson, D., & Grayson, K. (2005). Cognitive and affective trust in service relationships. *Journal of Business Research*, 58(4), 500-507. [https://doi.org/10.1016/S0148-2963\(03\)00140-1](https://doi.org/10.1016/S0148-2963(03)00140-1)
- Johnson, P. O., & Fay, L. C. (1950). The Johnson-Neyman technique, its theory and application. *Psychometrika*, 15(4), 349-367.
- Johnson, P. O., & Neyman, J. (1936). Tests of certain linear hypotheses and their application to some educational problems. *Statistical Research Memoirs*.
- Jones, M. V., Paull, G. C., & Erskine, J. (2002). The impact of a team's aggressive reputation on the decisions of association football referees. *Journal of Sports Sciences*, 20(12), 991-1000. <https://doi.org/10.1080/026404102321011751>
- Jussupow, E., Benbasat, I., & Heinzl, A. (2020). Why are we averse towards algorithms? A comprehensive literature review on algorithm aversion. Retrieved from [https://aisel.aisnet.org/ecis2020\\_rp/168](https://aisel.aisnet.org/ecis2020_rp/168)
- Logg, J. M., Minson, J. A., & Moore, D. A. (2019). Algorithm appreciation: People prefer algorithmic to human judgment. *Organizational Behavior and Human Decision Processes*, 151, 90-103. <https://doi.org/10.1016/j.obhdp.2018.12.005>
- Longoni, C., Bonezzi, A., & Morewedge, C. K. (2019). Resistance to medical artificial intelligence. *Journal of Consumer Research*, 46(4), 629-650. <https://doi.org/10.1093/jcr/ucz013>
- Li, Z., Rau, P. L. P., & Huang, D. (2020). Who should provide clothing recommendation services: artificial intelligence or human experts?. *Journal of Information Technology Research (JITR)*, 13(3), 113-125. <https://doi.org/10.4018/JITR.2020070107>
- Manzey, D., Reichenbach, J., & Onnasch, L. (2012). Human performance consequences of automated decision aids: The impact of degree of automation and system experience. *Journal of Cognitive Engineering and Decision Making*, 6(1), 57-87. <https://doi.org/10.1177/1555343411433844>
- Mascarenhas, D. R., Collins, D., & Mortimer, P. (2005). Elite refereeing performance: Developing a model for sport science support. *The Sport Psychologist*, 19(4), 364-379. <https://doi.org/10.1123/tsp.19.4.364>
- Monin, B. (2003). The warm glow heuristic: When liking leads to familiarity. *Journal of Personality and Social Psychology*, 85(6), 1035. <https://doi.org/10.1037/0022-3514.85.6.1035>.
- Murdock, B. B. (1962). The serial position effect of free recall. *Journal of Experimental Psychology*, 64(5), 482-488. <http://dx.doi.org/10.1037/h0045106>
- Nevill, A. M., Balmer, N. J., & Williams, A. M. (2002). The influence of crowd noise and experience upon refereeing decisions in football. *Psychology of Sport and Exercise*, 3(4), 261-272. [https://doi.org/10.1016/S1469-0292\(01\)00033-4](https://doi.org/10.1016/S1469-0292(01)00033-4)
- Önkal, D., Gönül, M. S., & De Baets, S. (2019). Trusting forecasts. *Futures & Foresight Science*, 1(3-4), e19. <https://doi.org/10.1002/FFO2.19>
- Patterson, P. G., & Mattila, A. S. (2008). An examination of the impact of cultural orientation and familiarity in service encounter evaluations. *International Journal of Service Industry Management*, 19(5), 662-681. <https://doi.org/10.1108/09564230810903514>.
- Potthoff, R. F. (1964). On the Johnson-Neyman technique and some extensions thereof. *Psychometrika*, 29(3), 241-256.
- Prahl, A., & Van Swol, L. (2017). Understanding algorithm aversion: When is advice from automation discounted?. *Journal of Forecasting*, 36(6), 691-702. <https://doi.org/10.1002/for.2464>
- Roberts, C. (2010). Correlations among variables in message and messenger credibility scales. *American Behavioral Scientist*, 54(1), 43-56. DOI: 10.1177/0002764210376310
- Unkelbach, C., & Memmert, D. (2010). Crowd noise as a cue in referee decisions contributes to the home advantage. *Journal of Sport and Exercise Psychology*, 32(4), 483-498. <https://doi.org/10.1123/jsep.32.4.483>
- Van Quaquebeke, N., & Giessner, S. R. (2010). How embodied cognitions affect judgments: Height-related attribution bias in football foul calls. *Journal of Sport and Exercise Psychology*, 32(1), 3-22. <https://doi.org/10.1123/jsep.32.1.3>
- Wagner, A. R., Borenstein, J., & Howard, A. (2018). Overtrust in the robotic age. *Communications of the ACM*, 61(9), 22-24. <https://doi.org/10.1145/3241365>

Zhang, R. X., Wang, N., Peng, Y. X. (2023). The impact of live streamer type and live streaming scene type on agricultural product purchase intention: A psychological distance perspective. In Li, E.Y. *et al.* (Eds) *Proceedings of The International Conference on Electronic Business, Volume 23* (pp. 750-756). ICEB'23, Chiayi, Taiwan, October 19-23, 2023.

## The Impact of Live Streamer Type and Live Streaming Scene Type on Agricultural Product Purchase Intention: A Psychological Distance Perspective

Ruixuan Zhang <sup>1</sup>

Nan Wang <sup>2,\*</sup>

Yuxing Peng <sup>3</sup>

\*Corresponding author

<sup>1</sup> Wuhan University, Wuhan, China, 2020302111129@whu.edu.cn

<sup>2</sup> Wuhan University, Wuhan, China, nanwang@whu.edu.cn

<sup>3</sup> Wuhan University, Wuhan, China, 2019302170019@whu.edu.cn

### ABSTRACT

With the development of live streaming, it is becoming widely adopted by farmers to broadcast their agricultural products. Despite its practical prevalence, the theoretical understanding of the purchase of agricultural products in the live-streaming context is still lacking. To fill this gap, based on the theory of psychological distance, this study focuses on the roles of two context-specific factors namely the live streaming scene of production place and the live streamer type of famers, and investigates their impact on agricultural product purchase intention together with brand awareness. A 2 (streamer type) × 2 (scene type) × 2 (brand awareness) factorial experiment is designed to validate the proposed research model. Expected theoretical and practical contributions are discussed.

*Keywords:* Live streaming, agricultural products, live streamer type, live streaming scene type, psychological distance, trust, purchase intention.

### INTRODUCTION

Live streaming has become one of the important sales methods for online sellers, through which online store sellers can display more information about their products, such as dynamic details, user experience, and production processes. According to the 51st Statistical Report on the Development of China's Internet released by the China Internet Network Information Center (CNNIC), the number of e-commerce live-streaming users exceeded 515 million in December 2022, a year-on-year increase of 51.05 million. Meanwhile, the popularization of live-streaming e-commerce in rural areas are accelerating. More and more farmers are promoting agricultural products through live streaming. Many agricultural products that are unsold or unable to open up the market due to insufficient popularity have been improved and increased in sales by using live streaming. According to the Power of Douyin E-commerce in Rural Development during the 2022 Harvest Festival, the number of merchants increases by 152% and 2.83 billion agricultural products are sold on Douyin platform from September 2021 to September 2022.

Although it is popular in practice to use live streaming for selling agricultural product, research on the influence of live streaming on agricultural product purchase are very few. First, only limited studies paid attention to the characteristics of agricultural product (Dong et al., 2022; Guo et al., 2022; Song et al., 2022; Zheng et al., 2023) and most previous studies did not distinguish product categories which triggered several issues. For example, compared to other types of products, agricultural products have significant uncertainty in transportation and taste, making it difficult for consumers to evaluate the quality. Thus, the results of these findings may not work for agricultural products. Second, previous studies discussed factors affecting purchase intention which includes IT affordance, product-related factors, and consumer-related factors. (Sun et al., 2019; Men et al., 2023; Lu & Chen, 2021; Park & Lin, 2020; Chen et al., 2022). Less attention has been paid to the impact of live streaming scene on product purchase intention. However, for agricultural product broadcasting, there is a unique scene such as the production place scene which involves the place where the product is produced in the countryside which could provide rich information about the agricultural products to reduce product uncertainty. Third, farmers can broadcast the product themselves aside from using professional streamer. Although previous study has discussed the streamer type on product purchase intention (Liu & Yu, 2022; Guo & Sun, 2022), the impact of using famer as the live streamer on product purchase intention is unclear. Thus, to summarize, our study aims to find out impact of these two context-based designs compared with traditional designs such as indoor studio scenes and professional streamers on agricultural product purchase intention is unclear. Two main research questions are proposed as follows:

RQ1: Which type of live streaming scene has a higher impact on agricultural products purchase intentions, indoor studio or production place, and when?

RQ2: Which type of live streamer has a higher impact on agricultural product purchase intentions, farmer or professional steamer, and when?

As psychological distance theory is used to explain product purchase behavior, we would like to adopt this theory to explain these two research questions. We contend that both live streaming scenes and live streamers will impact psychological distance, and different types of live streaming scenes and live streamers could trigger different degrees of psychological distance. Psychological distance could then impact trust which promotes agriculture product purchase.

## LITERATURE REVIEW

### Live Streaming and Agriculture Product Purchase

Previous studies on purchase behavior in the live streaming context has investigated factors affecting purchase intention which includes IT function, such as visibility, meta voicing, guidance shopping, immersion, presence (Sun et al., 2019), interactivity (Men et al., 2023), product-related factors such as product quality uncertainty or fit uncertainty (Lu & Chen, 2021), influencer-product fit, live content-product fit (Park & Lin, 2020), consumer-related factor including utilitarian and hedonic motivations, and broadcaster-related factors, such as perceived expertise, similarity, familiarity, and likeability (Chen et al., 2022).

Table 1: Literature Review of Related Studies on Live Streaming

Reference	Live-streaming Design	Dependent Variables	Streamer type	Scene Type	Agricultural Product
(Sun et al., 2019)	Visibility; Meta voicing; Guidance shopping; Immersion; Presence	Purchase intention	No	No	No
(Park & Lin, 2020)	Wanghong-product fit; Live content-product fit; Wanghong trustworthiness; Wanghong attractiveness	Purchase intention	No	No	No
(Lu & Chen, 2021)	Physical characteristic similarity; Value similarity; Product fit uncertainty; Trust; Product quality uncertainty	Purchase intention	No	No	No
(Chen et al., 2022)	Perceived expertise; Perceived similarity; Perceived familiarity; Perceived likeability	Purchase intention	No	No	No
(Zheng, Lyu, Wang, & Wachenheim, 2023)	Influence; Sales promotion; Interactive entertainment; Environmental problem perception; Green consumption awareness; Green consumption cognition	Consumers' purchasing behavior	No	No	yes
(Yu & Zhang, 2022)	Perceived interactivity; Perceived effectiveness of e-commerce institutional mechanism; Perceived endorsement; Shipping; Product familiarity; Subjective norms; Altruistic value; Live shopping experience	Purchase intention	No	No	yes
(Dong, Zhao, & Li, 2022)	Information Quality; System Quality; Service Quality; Telepresence; Social Presence	Green purchase Intention	No	No	Yes
(Liu & Yu, 2022)	Streamer type; Product type; Brand awareness	Purchase intention	Yes	No	No
(Guo & Sun, 2022)	Streamer trustworthiness; Streamer expertise; Streamer responsiveness; Information quality; Bullet screen mutuality	Purchase intention	Yes	No	Yes
This Study	Live streamer type; Live streaming scene; Brand awareness	Purchase intention	Yes	Yes	Yes

As shown in Table 1, there are some literature gaps of related studies. First, most previous studies did not distinguish product categories, with a few studies focusing on agricultural products (Dong et al., 2022; Guo et al., 2022; Song et al., 2022; Zheng et al., 2023). While the quality of agricultural products is more difficult to evaluate than most other products, the factors impacting agricultural product purchase intention would be different. Second, previous studies explore factors that affect consumer purchasing intention including information, system, service quality, effectiveness of e-commerce institutional mechanism (Dong et al., 2022), trustworthiness, expertise, responsiveness (Guo et al., 2022; Song et al., 2022; Wang & Fan, 2021; Zheng et al., 2023), Locality, seasonality, eco-friendliness of green agri-food (Wang & Fan, 2021), the impact of streamer type and scene type is less studies.

### Construal Level Theory and Psychological Distance Theory

In social psychology, the relationship between an individual's construal level and psychological distance is usually elucidated based on the construal level theory (Liberman & Trope, 1998; Nira Liberman et al., 2007). "Psychological distance is defined as the degree to which an object is perceived to be tangible or immediately present in terms of the here-and-now" (Trope et al., 2007). According to CLT (Construal level theory), the way people subjectively represent and explain events will be influenced by psychological distance (Tugrul & Lee, 2018). The antecedents and outcomes of psychological distance have been addressed in previous studies. For example, the psychological distance between users can be reduced through inhabited space and the isomorph effect (Lim et al., 2012). Previous research indicated that live interactions positively affect psychological distance (Xue et al., 2020). Vicarious learning strategies can promote consumers' psychological proximity which further positively impacts consumers' personal value (Men et al., 2023). Previous studies have shown that using simple website strategies can reduce psychological distance, thereby enhancing trust and purchasing behavior (Darke et al., 2016). There has been research that applied the theory and proved that live streaming strategy could shorten psychological distance which then negatively affects online purchase intention (Zhang et al., 2020). However, in the field of live streaming research especially for agricultural product purchase behavior, the theory of psychological distance is less adopted.

As psychological distance can be used to explain online purchase behavior, we adopt it to explain agricultural product purchase intention. Live streaming can present the original information of products, enabling consumers to have a more comprehensive understanding of the products. While psychological distance can be towards objects, people, or events, we are also interested in both product and social psychological distance as product and streamer perception would impact purchase intention. Further, as live interactions or design could impact psychological distance, such as the presence and interactivity of live streaming (Xue et al., 2020), our study will also discuss the live streaming design which includes the streamer design and scene design on psychological distance on the purchase intention.

### RESEARCH MODEL AND HYPOTHESES DEVELOPMENT

Our study is devoted to explaining the impact of both streamer type and scene type on purchase intention. We divided the psychological distance into product psychological distance and social psychological distance and classified the trust into trust in the product and trust in the streamer. We contend that streamer and scene could impact psychological distance, and brand awareness could moderate this impact. Psychological distance can impact trust which then promotes purchase intention. The research model is shown in Figure 1.

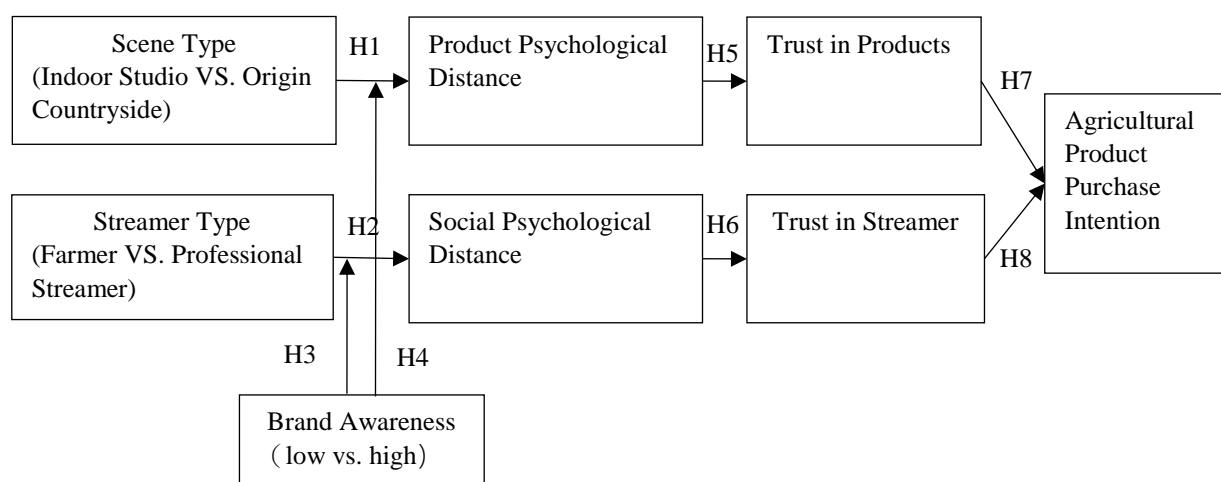

Figure 1. Research Model

### Scene Type, Streamer Type and Psychological Distance

According to psychological distance theory, the abstracted level of information will influence the psychological distance level (Nira Liberman et al., 2007). Compared with a scene of an indoor studio, the scene of the production place provides more detailed information about the product such as the environment where the products are growing. Live streaming presents the details of the origin environment and the process of product generation to consumers in real-time video format. Previous research mentioned that the correlation of spatial context has a great impact on psychological distance perception (Fujita et al., 2006). By presenting the origin, consumers receive more detailed information about agricultural product production, as if they are in rural farmland or planting sheds, in order to bring closer geographical proximity. Thus, we proposed that the scene of production place could induce lower psychological distance than the scene of an indoor studio. The streamer type of farmer is perceived as simpler, with a high level of authenticity and empathy, creating a sense of familiarity among consumers (Rodin, 2023). Based on CLT, familiarity can reduce the psychological distance (Lii et al., 2012). Further, empathy is closely related to psychological distance (Lee et al., 2018). Thus, we contend:

H1: Compared with a scene of an indoor studio, a scene of a production place can cause shorter customers' product psychological distance.

H2: Compared with the professional streamers, the farmers can cause shorter customers' psychological distance towards the products.

### The Moderating Effect of Brand Awareness

Brand awareness means the strength of the brand node in memory (Yoo et al., 2000). With a high brand awareness, consumer could easily recognize the brand among other brands. Brand awareness is widely accepted as an additional value for a brand which means even without enough information brand itself could provide a quality signal to consumers to induce their purchase behavior. In live streaming, with a higher brand awareness, the positive impact of concrete information might be decreased. Thus, we contend that the positive impact of the scene of production place will be decreased. Similarly, with a higher brand awareness, the positive impact of the streamer of farmer will also be decreased. Thus, we proposed:

H3: Brand awareness moderates the impact of scene type on product psychological distance.

H4: Brand awareness moderates the impact of streamer type on social psychological distance.

### Psychological Distance and Trust

According to psychological distance, the psychological distance could influence the perception of the abstract level of the object or people (Nira Liberman et al., 2007). Thus, with a lower psychological distance, the concrete level of the object or people will be higher. In our study, we distinguish psychological distance into product psychological distance and social psychological distance. Lower product psychological distance means consumers have a more concrete perception of the product, which could help consumers reduce their product uncertainty and promote trust in the product. Second, psychological proximity could boost trust as higher social psychology distance induces distrust (Harwood & Lin, 2000). Thus, we contend:

H5: Product psychological distance negatively affect trust in the products.

H6: Social psychological distance negatively affect trust in the streamer.

### Trust and Agricultural Product Purchase Intention

Trust is defined as the consumer's belief that a certain online store or people can be relied upon even if there exists the possibility of loss (Komiak & Benbasat, 2004; Sia et al., 2009). In previous literature, trust is proved to be a major antecedent of product purchase intention in e-commerce platforms (Venkatesh et al., 2012). In the context of live streaming, previous research demonstrated a positive impact on product purchase intention (Lu & Chen, 2021). This study distinguishes trust into trust in product and trust in streamers. Trust in the product means that the product will ensure the expected quality (Wongkitrungrueng & Assarut, 2020), and trust in the streamers indicates that the streamer is honest, and expert and does not exaggerate and falsify product information (Lu et al., 2010). Wongkitrungrueng and Assarut (2020) divided trust into trust in agriculture products and trust in sellers and proved that both trust in agriculture products and trust in sellers could promote engagement in the agriculture products live streaming. As engagement could further promote product purchase intention (Shi et al., 2022). Thus, we contend that trust in agriculture products and trust in streamers will positively impact purchase intention.

Thus, we proposed:

H7: Trust in the product positively affect consumers' purchase intention towards agricultural product.

H8: Trust in the streamer positively affect consumers' purchase intention towards agricultural product.

## RESEARCH METHODOLOGY

### Experimental Design

A 2-scene Type (Indoor studio VS. Production place) × 2 Streamer Type (Farmer VS. Professional Streamer) × 2 Brand awareness (Low VS. High) factorial experiment is designed and 8 corresponding live streaming screening pictures will be designed. The scene Type is manipulated as the place of live streaming either in the indoor studio or in the production place of

the agricultural product in the countryside and the streamer type is designed as either a farmer or a professional streamer. For brand awareness, we will conduct a pretest to select the same type of agricultural product but with either high brand awareness or low awareness. Among 8 scenarios, product price, number of audiences, number of followers, number of comments, and content of the comments are controlled as the same.

Participants were randomly assigned to eight experimental groups. After they browse the live-streaming screening pictures, they will fill in the questionnaire. The questionnaire includes three parts. The first part includes questions about manipulation checks of streamer type, scene type, and brand awareness level. After that, we measure product psychological distance, social product distance participants' trust and purchase intention. Finally, demographic information such as age, gender, and education level will be measured. Constructs and measurements are listed in Table 2.

Table 2: Constructs and Measurement

Constructs	Measurement	Source
Manipulation Check of Streamer Type	Which one is the streamer in the live streaming? 0 = a famer, 1= a professional streamer.	(Liu & Yu, 2022)
Manipulation Checks of Scene Type	What is the scene in the live streaming? 0 = production place, 1= indoor studio.	(Liu & Yu, 2022)
Product Psychology Distance	<ol style="list-style-type: none"> <li>1. While watching the live streaming, how physically close are you to the product? [Very Close. . .Very Distant]</li> <li>2. While watching the live streaming, how abstract are the product in your mind Abstract = Difficult to Imagine   Concrete = Easy to Imagine [Very Concrete. . .Very Abstract].</li> <li>3. While watching the live-streaming, how tangible are the attributes of the product in your mind? Tangibility is the extent to which you can sense (e.g., see, touch, hear, taste, or smell) the object of interest. [Very Tangible. . .Very Intangible].</li> <li>4. While watching live-streaming, how real do they seem in your mind? [Very Real. . .Very Hypothetical].</li> </ol>	(Darke et al., 2016)
Social Psychology Distance	<ol style="list-style-type: none"> <li>1. While watching the live streaming, how physically close are you to the streamer? [Very Close. . .Very Distant]</li> <li>2. While watching the live streaming, how abstract are the streamer in your mind? Abstract = Difficult to Imagine   Concrete = Easy to Imagine [Very Concrete. . .Very Abstract].</li> <li>3. While watching the live streaming, how tangible are the attributes of the streamer in your mind? Tangibility is the extent to which you can sense (e.g., see hear) the people. [Very Tangible. . .Very Intangible].</li> <li>4. While watching live-streaming, how real do they seem in your mind? [Very Real. . .Very Hypothetical].</li> </ol>	(Darke et al., 2016)
Trust in Product	<ol style="list-style-type: none"> <li>1. I think the products I order from the live streaming will be as I imagined.</li> <li>2. I believe that I will be able to use products like those demonstrated in the live streaming.</li> <li>3. I trust that the products I receive will be the same as those shown in the live streaming.</li> </ol>	(Wongkitrungrueng & Assarut, 2020)
Trust in Streamer	<ol style="list-style-type: none"> <li>1. The streamer is like a real expert in assessing the products.</li> <li>2. The streamer keeps my interests in mind.</li> <li>3. I consider this streamer to possess integrity.</li> </ol>	(Lu & Chen, 2021)
Brand Awareness	<ol style="list-style-type: none"> <li>1. I know how the brand featured in the live streaming looks like.</li> <li>2. I can recognize the brand among other competing brands.</li> <li>3. I am aware of the brand in live streaming.</li> </ol>	(Yoo et al., 2000)
Agricultural Product Purchase Intention	<ol style="list-style-type: none"> <li>1. I am very likely to buy the agricultural product from the streamer.</li> <li>2. I would consider buying the agricultural product from the streamer in the future.</li> <li>3. I intend to buy the agricultural product from the streamer.</li> </ol>	(Lu & Chen, 2021)

Data collection will be conducted on an online questionnaire platform. This study will further validate the validity of the hypothesis through questionnaire data. It is expected to collect three hundred valid data samples and provide certain material

rewards to the participants in the experiment. Data processing will be conducted using SPSS, and multiple methods will be used to analyze the data.

### EXPECTED CONTRIBUTION

This study contributes both theoretically and practically. From a theoretical perspective, this study first contributes to the literature on the live streaming by investigating the special product type of agricultural products purchase intention in live streaming context. Second, this study extends previous research by focusing on the impact of the live streaming design of the scene of production place and streamer type of the farmer on agricultural product purchasing intention. Furthermore, by applying psychological distance theory to the context of live streaming, this study extends the applied scope of the theory. From a practical perspective, the results could provide guidelines for agricultural products selling strategies through live-streaming.

### REFERENCES

- Chen, Zhang, Shao, Gao, & Xu. (2022). How do interpersonal interaction factors affect buyers' purchase intention in live stream shopping? The mediating effects of swift guanxi. *Internet Research*, 32(1), 335-361.
- Darke, Brady, Benedictus, & Wilson. (2016). Feeling Close From Afar: The Role of Psychological Distance in Offsetting Distrust in Unfamiliar Online Retailers. *Journal of Retailing*, 92(3), 287-299.
- Dong, Zhao, & Li. (2022). The Role of Live-Streaming E-Commerce on Consumers' Purchasing Intention regarding Green Agricultural Products. *Sustainability*, 14(7).
- Fujita, Henderson, Eng, Trope, & Liberman. (2006). Spatial distance and mental construal of social events. *Psychological Science*, 17(4), 278-282.
- Guo, Sun, Pan, Xu, & Yan. (2022). The Sustainability of Fresh Agricultural Produce Live Broadcast Development: Influence on Consumer Purchase Intentions Based on Live Broadcast Characteristics. *Sustainability*, 14(12).
- Harwood, & Lin. (2000). Affiliation, pride, exchange, and distance in grandparents' accounts of relationships with their college-aged grandchildren. *Journal of Communication*, 50(3), 31-47.
- Komiak, & Benbasat. (2004). Understanding Customer Trust in Agent-Mediated Electronic Commerce, Web-Mediated Electronic Commerce, and Traditional Commerce. *Information Technology and Management*, 5(1), 181-207.
- Lee, Hon, & Won. (2018). Psychological proximity as a predictor of participation in a social media issue campaign. *Computers in Human Behavior*, 85, 245-254.
- Liberman, & Trope. (1998). The role of feasibility and desirability considerations in near and distant future decisions: A test of temporal construal theory. *Journal of Personality and Social Psychology*, 75(1), 5-18.
- Liberman, Trope, & Wakslak. (2007). Construal level theory and consumer behavior. *Journal of Consumer Psychology*, 17(2), 113-117.
- Lii, Pant, & Lee. (2012). Balancing the scales: recovering from service failures depends on the psychological distance of consumers. *Service Industries Journal*, 32(11), 1775-1790.
- Lim, Cha, Park, Lee, & Kim. (2012). Getting closer and experiencing together: Antecedents and consequences of psychological distance in social media-enhanced real-time streaming video. *Computers in Human Behavior*, 28(4), 1365-1378.
- Liu, & Yu. (2022). Impact of perceived diagnosticity on live streams and consumer purchase intention: streamer type, product type, and brand awareness as moderators. *Information Technology & Management*.
- Lu, & Chen. (2021). Live streaming commerce and consumers' purchase intention: An uncertainty reduction perspective. *Information & Management*, 58(7).
- Lu, Zhao, & Wang. (2010). From virtual community members to C2C e-commerce buyers: Trust in virtual communities and its effect on consumers' purchase intention. *Electronic Commerce Research and Applications*, 9(4), 346-360.
- Men, Zheng, & Davison. (2023). The role of vicarious learning strategies in shaping consumers' uncertainty: the case of live-streaming shopping. *Internet Research*.
- Park, & Lin. (2020). The effects of match-ups on the consumer attitudes toward internet celebrities and their live streaming contents in the context of product endorsement. *Journal of Retailing and Consumer Services*, 52.
- Shi, Leung, & Munelli. (2022). Gamification in OTA platforms: A mixed-methods research involving online shopping carnival. *Tourism Management*, 88.
- Sia, Lim, Leung, Lee, Huang, & Benbasat. (2009). Web Strategies to Promote Internet Shopping: Is Cultural-Customization Needed? *Mis Quarterly*, 33(3), 491-512.
- Song, Liu, & Shi. (2022). How Do Fresh Live Broadcast Impact Consumers' Purchase Intention? Based on the SOR Theory. *Sustainability*, 14(21), 16.
- Sun, Shao, Li, Guo, & Nie. (2019). How live streaming influences purchase intentions in social commerce: An IT affordance perspective. *Electronic Commerce Research and Applications*, 37.
- Trope, Liberman, & Wakslak. (2007). Construal levels and psychological distance: Effects on representation, prediction, evaluation, and behavior. *Journal of Consumer Psychology*, 17(2), 83-95.
- Tugrul, & Lee. (2018). Promoting charitable donation campaigns on social media. *Service Industries Journal*, 38(3-4), 149-163.
- Venkatesh, Thong, & Xu. (2012). Consumer Acceptance and Use of Information Technology: Extending the Unified Theory of Acceptance and Use of Technology. *Mis Quarterly*, 36(1), 157-178.
- Wang, & Fan. (2021). An Empirical Study on How Livestreaming Can Contribute to the Sustainability of Green Agri-Food Entrepreneurial Firms. *Sustainability*, 13(22), 19.
- Wongkitrungrueng, & Assarut. (2020). The role of live streaming in building consumer trust and engagement with social



- commerce sellers. *Journal of Business Research*, 117, 543-556.
- Xue, Liang, Xie, & Wang. (2020). See now, act now: How to interact with customers to enhance social commerce engagement? *Information & Management*, 57(6).
- Yoo, Donthu, & Lee. (2000). An examination of selected marketing mix elements and brand equity. *Journal of the Academy of Marketing Science*, 28(2), 195-211.
- Zhang, Qin, Wang, & Luo. (2020). The impact of live video streaming on online purchase intention. *Service Industries Journal*, 40(9-10), 656-681.
- Zheng, Lyu, Wang, & Wachenheim. (2023). Enhancing Sales of Green Agricultural Products through Live Streaming in China: What Affects Purchase Intention? *Sustainability*, 15(7).

## The Prototypical Framing Effect in Product Recommendation

Yimei Yuan <sup>1</sup>  
Bin Ling <sup>2,\*</sup>

\*Corresponding author

<sup>1</sup> Senior Engineer, Guangdong Polytechnic of Water Resources and Electric Engineering, Guangzhou, China, 709979196@qq.com

<sup>2</sup> Associate Professor, Hohai University, Nanjing, China, ling.bin@hotmail.com

### ABSTRACT

Product recommendations influence consumers' purchasing decisions, but not all advice is equally persuasive. This research examines how the framing of recommendations impacts advice-taking and buying behavior. Integrating prototypicality and framing theories, we propose the concept of a prototypical framing effect whereby advice framed with prototypical cues is more influential than advice framed peripherally. A pilot study conceptualizes this effect and develops experimental materials. Study one tests hypotheses that prototypically-framed advice increases advice-taking (H1) and buying behavior (H2) compared to peripherally-framed advice. Study two also examines identity salience as a moderator, hypothesizing stronger prototypical framing effects when identity salience is high (H3 & H4). Results will demonstrate the persuasive impact of prototypical recommendation frames, offering theoretical and practical insight into effective advice-giving. This research elucidates how subtle framing techniques can shape consumers' receptiveness to recommendations and willingness to purchase recommended products.

*Keywords:* framing effect, prototypicality, product recommendation, advice-taking

### INTRODUCTION

Product recommendations play a vital role in informing consumers' purchasing choices. For instance, consumers rely on advice to select an appropriate memory card model for their digital camera before buying (Kowatsch & Maass, 2010). Recommendations provide useful information to help consumers find satisfactory products, both in-store and online. However, not all advice is equally effective or persuasive. Consumers may accept certain recommendations while dismissing others (Gershoff et al., 2001; Yeomans, 2019). This research aims to elucidate this issue by examining how the framing of recommendation information impacts its influence (e.g., framing effect, see Tversky & Kahneman, 1981).

Specifically, integrating theories of social identity and identity framing (Hogg, 2012; Seyranian, 2013, 2014), we propose the concept of a prototypical framing effect for product recommendations. This refers to the principle that the way advice is represented, via prototypical cues or situations, shapes whether it is accepted. Framing induces cognitive biases that systematically affect choices (Tversky & Kahneman, 1981). Different frames for recommendation information may elicit varying product evaluations and preferences.

This research aims to elucidate the proposed prototypical framing effect in product recommendations, testing whether prototypically-framed advice increases advice-taking and purchasing. Group prototypicality provides a cognitive channel for framing advice differently, such as through prototypical vs. peripheral cues. Prototypical frames establish stronger ties between the recipient's self-concept and the advice, whereas peripheral frames have weaker self-concept ties. We expect prototypical advice to be more effective and persuasive than peripheral advice. This is because prototypicality draws attention and encourages deliberative processing (van Knippenberg & Hogg, 2003). It strengthens the recipient's self-perception of membership in the group giving the advice. In this way, prototypical framing enhances advice receptiveness and persuasiveness compared to peripheral framing.

### RESEARCH QUESTIONS

This research attempts to resolve the following three main questions:

- 1) What is the prototypical framing effect in a product recommendation context (conceptualization and characteristics)? And how to represent recommendation with prototypicality?
- 2) What do people obtain from the prototypical framing? To compare whether there is a difference of advice-taking and buying behavior between prototypical framing and peripheral framing?
- 3) When does this prototypical framing effect hold and when does it not hold? To investigate the boundary condition of the prototypical framing effect in term of identity salience.

## THEORETICAL FRAMEWORK AND HYPOTHESIS

We develop two propositions explore the construct of the prototypical framing effect of product recommendation and its characteristic.

*Proposition 1:* There is a prototypical framing to represent advice in product recommendation system.

*Proposition 2:* The prototypical framing effect can be classified as two frames—prototypical frame and peripheral frame.

In recent years, consumer behavior research has increasingly recognized the influential role of social identity in shaping individuals' decision-making Babar et al. (In press). A person's choices as a consumer are motivated not solely by their personal tastes and preferences. Their purchases are also driven by a psychological sense of belongingness to salient social groups and a desire to express this identification. When consumers feel a strong affinity and allegiance with a particular social group, whether based on demographics, culture, lifestyle, or values, their consumption tendencies are swayed by this salient identity (van Knippenberg & Hogg, 2003). Marketers can leverage this effect by framing brands and products as encapsulating the central, prototypical qualities of an identity group. When a product is positioned and marketed in a way that taps into the core values, norms, and attributes symbolizing a consumer's meaningful social identity, those who strongly identify with that group become more compelled to purchase the product. This strategic product framing strengthens consumers' perception that buying the product helps affirm and signal their group identification and loyalty (see Figure 1).

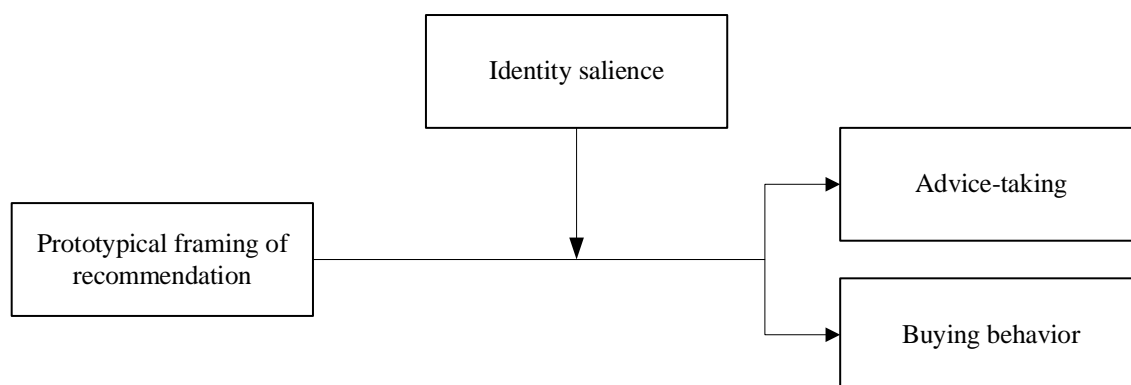

Figure 1: Theoretical framework

In addition to product framing, the way in which recommendations are communicated and framed influences how receptively consumers respond. Recommendations that are expressed in a manner that underscores essential, prototypical qualities of a valued social group resonate more strongly with consumers who identify with that group. When a recommendation accentuates attributes, values, and norms perceived as integral to the identity of the group, it takes on special meaning as a prototypical group recommendation. Consumers are more inclined to accept and internalize advice when it is prototypically framed in this way, as it allows them to feel alignment with the core values of their ingroup. In contrast, recommendations framed peripherally, calling attention to superficial preferences or ancillary traits, are viewed as tangential (Goldman & Hogg, 2016; Hogg, 2012, 2014; Hogg & Adelman, 2013). Rather than tapping into the defining essence of a group identity, peripheral framing only touches on incidental styles and tastes. This fails to elicit a strong sense of identity-based motivation to follow the recommendation. As such, consumers are less likely to be persuaded or give significant weight to peripherally framed recommendations, as they do not provide meaningful identity affirmation.

Therefore, to further examine these effects, we propose and test several hypotheses regarding the influence of prototypical versus peripheral framing of recommendations on critical consumer behaviors. Specifically, we develop hypotheses to investigate how prototypical framing impacts advice-taking and product purchase intent compared to peripheral framing. We also explore identity salience as a potential boundary condition that could enhance these framing effects. Identity salience refers to the prominence and significance that a particular identity holds for an individual, both in their own self-concept and in their perceptions of others (Hohman & Hogg, 2015; Stryker & Serpe, 1994). An identity with high salience is one that tends to be chronically accessible and active for the individual across different situations. When an identity is highly salient, individuals are motivated to maintain and affirm that identity through their attitudes and actions. Thus we predict identity salience may interact with recommendation framing, strengthening framing effects on behavior when salience is higher. Testing these hypotheses can provide greater insight into the relationship between social identification, advice persuasiveness, and consumption choices.

*Hypothesis 1:* The prototypical framing of recommendation has a more positive effect on advice-taking than the peripheral framing of recommendation.

*Hypothesis 2:* The prototypical framing of recommendation has a more positive effect on product buying behavior than the peripheral framing of recommendation.

*Hypothesis 3:* Identity salience has an interactive effect with recommendation framing on advice-taking. There is a stronger prototypical framing effect on advice-taking when the recipient has a higher identity salience.

*Hypothesis 4:* Identity salience has an interactive effect with recommendation framing on product buying behavior. There is a stronger prototypical framing effect on product buying behavior when the recipient has a higher identity salience.

## **RESEARCH DESIGN**

A pilot study will be used to develop the concept of prototypical framing of the product recommendation and its characteristic. Two experimental studies will be used to testify to the proposed hypotheses.

### **Pilot Study**

To effectively operationalize and test the effects of prototypical versus peripheral recommendation framing, we will first need to clearly conceptualize and develop concrete experimental materials instantiating these framing approaches. We will develop the conceptual foundation for prototypical framing of product recommendations by extensively reviewing relevant literature across social psychology, consumer research, and communication studies. This will identify recurring themes and dimensions characterizing messages and appeals framed to resonate with the core identity of a group. We will also conduct in-depth interviews with consumers to capture their perspectives on what makes a product recommendation feel prototypically representative of an identity group versus more peripheral.

The goal of this initial pilot study phase is twofold. First, synthesizing prior research and consumer insights will allow us to comprehensively delineate the key rhetorical and stylistic elements that define prototypical and peripheral framing of advice. Secondly, these characteristics will inform the systematic development of experimental recommendation materials embodying prototypical and peripheral framing conditions. Crafting controlled manipulations of recommendation framing is essential for rigorously testing causal effects on advice-taking and consumer behavior in subsequent experiments. Clearly delineating prototypical and peripheral framing dimensions through literature and interviews will provide a strong empirical basis for developing materials to directly compare their effects. Establishing a clear conceptual and methodological foundation will set the stage for controlled experiments examining how advice framing impacts important outcomes like advice adherence and purchase decisions.

### **Experiment One**

After developing well-defined prototypical and peripheral framing manipulations through the pilot study, we will conduct a between-subjects experiment to test the proposed main effect of prototypical framing on advice-taking and purchase behavior. The independent variable will be recommendation framing with two levels: prototypical vs. peripheral. The two key dependent variables are advice-taking and product purchase intent.

We will recruit participants to complete an online shopping scenario presenting a series of product recommendations. The framing of these recommendations will be experimentally manipulated between subjects as either prototypical or peripheral. After viewing each recommendation, participants will report their likelihood of following the advice on multi-item measures of advice-taking. They will then make a product selection and purchase choice.

This experiment will allow us to directly compare the effects of prototypical versus peripheral recommendation framing on advice-taking and simulated purchasing decisions. We hypothesize that exposure to advice framed prototypically will increase participants' reported intentions to follow the recommendations, compared to peripheral framing. We also predict prototypical framing will make participants more likely to choose the recommended product option to purchase. Observing these hypothesized main effects would provide evidence that prototypical recommendation framing enhances consumers' advice adherence and propensity to buy recommended products, compared to peripheral framing.

### **Experiment Two**

To test Hypotheses 3 and 4 regarding the proposed moderating role of identity salience, we will conduct a 2 (identity salience: high vs. low) x 2 (recommendation frame: prototypical vs. peripheral) between-subjects factorial experiment. The first independent variable will be identity salience, manipulated at two levels: high versus low. The second independent variable will again be recommendation framing: prototypical versus peripheral.

The key dependent variables measured will be the same as Experiment 1: advice-taking and product purchase intent. Participants will complete a similar simulated online shopping scenario with recommendation prompts. Additionally, we will incorporate identity salience manipulation tasks at the start of the study adapted from prior research. This will allow us to experimentally induce high or low identity salience related to the product domain.

The factorial combination of identity salience and recommendation framing conditions will enable analyzing their interaction on the dependent measures. We predict that identity salience will moderate the effect of framing on advice-taking and purchase decisions. Specifically, we hypothesize there will be stronger positive effects of prototypical framing on advice adherence and buying likelihood when identity salience is high rather than low. Observing this interactive pattern would provide evidence for Hypotheses 3 and 4 that identity salience enhances the impact of prototypical recommendation framing on consumer behavior. This experiment will build on the first by clarifying the boundary role of identity salience. It will demonstrate how group identification strengthens consumers' responses to strategically framed recommendations that tap into identity-relevant values.

### ACKNOWLEDGMENT

This work is supported by grant of the Guangdong Provincial Educational Science Planning Scheme (Higher Education Scheme; Projects no. 2022GXJK102).

### REFERENCE

- Babar, Y., Adeli, A. M., & Burtch, G. (In press). The effects of online social identity signals on retailer demand. *Management Science*, 0(0), null. <https://doi.org/10.1287/mnsc.2023.01168>
- Gershoff, A. D., Broniarczyk, S. M., & West, P. M. (2001). Recommendation or Evaluation? Task Sensitivity in Information Source Selection. *Journal of Consumer Research*, 28(3), 418-438. <https://doi.org/10.1086/323730>
- Goldman, L., & Hogg, M. A. (2016). Going to extremes for one's group: the role of prototypicality and group acceptance. *Journal of Applied Social Psychology*, 46(9), 544-553. <https://doi.org/10.1111/jasp.12382>
- Hogg, M. A. (2012). Uncertainty-identity theory. In P. A. Van Lange, A. W. Kruglanski, & E. T. Higgins (Eds), *Handbook of Theories of Social Psychology*, Vol. 2 (pp. 62-80). Sage Publications Ltd. <https://doi.org/10.4135/9781446249222.n29>
- Hogg, M. A. (2014). From uncertainty to extremism: Social categorization and identity processes. *Current Directions in Psychological Science*, 23(5), 338-342. <https://doi.org/10.1177/0963721414540168>
- Hogg, M. A., & Adelman, J. (2013). Uncertainty-identity theory: Extreme groups, radical behavior, and authoritarian leadership. *Journal of Social Issues*, 69(3), 436-454. <https://doi.org/10.1111/josi.12023>
- Hohman, Z. P., & Hogg, M. A. (2015). Fearing the uncertain: Self-uncertainty plays a role in mortality salience. *Journal of Experimental Social Psychology*, 57, 31-42. <https://doi.org/https://doi.org/10.1016/j.jesp.2014.11.007>
- Kowatsch, T., & Maass, W. (2010). In-store consumer behavior: How mobile recommendation agents influence usage intentions, product purchases, and store preferences. *Computers in Human Behavior*, 26(4), 697-704. <https://doi.org/https://doi.org/10.1016/j.chb.2010.01.006>
- Seyranian, V. (2013). Social identity framing: A strategy of social influence for social change. In R. E. Riggio & S. J. Tan (Eds.), *Leader Interpersonal and Influence Skills: The Soft Skills Of Leadership*. Taylor and Francis.
- Seyranian, V. (2014). Social identity framing communication strategies for mobilizing social change. *The Leadership Quarterly*, 25(3), 468-486. <https://doi.org/https://doi.org/10.1016/j.leaqua.2013.10.013>
- Stryker, S., & Serpe, R. T. (1994). Identity salience and psychological centrality: equivalent, overlapping, or complementary concepts? *Social Psychology Quarterly*, 57(1), 16-35. <https://doi.org/10.2307/2786972>
- Tversky, A., & Kahneman, D. (1981). The framing of decisions and the psychology of choice. *Science*, 211(4481), 453. <https://doi.org/10.1126/science.7455683>
- van Knippenberg, D., & Hogg, M. A. (2003). A social identity model of leadership effectiveness in organizations. *Research in Organizational Behavior*, 25, 243-295. [https://doi.org/https://doi.org/10.1016/S0191-3085\(03\)25006-1](https://doi.org/https://doi.org/10.1016/S0191-3085(03)25006-1)
- Yeomans, M. (2019). Some hedonic consequences of perspective-taking in recommending. *Journal of Consumer Psychology*, 29(1), 22-38. <https://doi.org/10.1002/jcpsy.1050>

## Unlocking Opportunities Amidst Obstacles: Navigating Digital Transformation Challenges in China's Manufacturing Towns for Small and Medium-Sized Enterprises

Nan Jiang <sup>1</sup>  
Ruilin. Zhu <sup>2,\*</sup>

\*Corresponding author

<sup>1</sup> PG Student, Lancaster University Management School, Lancashire, UK, jiangnansh2@163.com

<sup>2</sup> Lecturer, Lancaster University Management School, Lancashire, UK, ruilin.zhu@lancaster.ac.uk

### ABSTRACT

This research-in-progress paper aims to delve into the challenges confronted by small and medium-sized enterprises (SMEs) operating within a small equipment manufacturing town in China during their digital transformation journey. While a considerable body of literature exists on digital transformation and SMEs, there is a notable absence of insights at the manufacturing town level, which is a significant and yet understudied phenomenon. Our study is situated in a well-known manufacturing town within a city, employing an in-depth qualitative approach. By scrutinizing the underlying causes of challenges that have led to delayed or aborted digital transformations, this research seeks to offer a more profound understanding of digital transformation within the manufacturing industry, with a specific focus on SMEs. Additionally, our findings are expected to provide valuable policy insights and references for the manufacturing town's ongoing digital transformation efforts.

*Keywords:* Digital transformation, SMEs, manufacturing town, qualitative research, China.

### INTRODUCTION

Discussing the challenges faced in the digital transformation of small and medium-sized enterprises (SMEs) is no longer a singular concern. Current research has delved extensively into the digital transformation of these enterprises across various industries, particularly the obstacles encountered during this process, resulting in comprehensive findings (Parviainen, 2017). As the evolution of commercial digitalization continues, even the less rapidly progressing small and medium-sized manufacturing enterprises have initiated transformations in areas such as production and management. Throughout this transformation journey, numerous issues have surfaced, leading to a plethora of related studies. Nonetheless, the majority of these investigations focus on individual case studies within specific industries or companies, failing to encompass the challenges faced by small and medium-sized enterprises within manufacturing clusters, which form a significant portion of China's economic growth. Given the importance of Chinese SMEs, which account for 99.7% of the manufacturing enterprises in China (Geng, Lai & Zhu, 2021), and manufacturing towns, a prevalent manifestation of China's manufacturing landscape, which contribute to the essential underpinning of the local economic framework (Aranya, 2008), this study seeks to examine the difficulties encountered during their digital transformation by selecting a number of leading SMEs in a well-known manufacturing town in China as samples.

The digital transformation landscape has undergone a significant shift in recent years, rendering it increasingly accessible and cost-effective. Technological advancements and societal evolution have paved the way for small and medium-sized enterprises (SMEs) to tap into specialized expertise capable of navigating the intricate technical intricacies that often accompany the digital transformation process. Furthermore, with a growing emphasis on intelligent manufacturing within China's manufacturing sector, as noted in the Economic Daily (2021), governmental bodies and a diverse range of institutions have stepped forward to extend financial and technical support, aiming to facilitate the digital transformation of enterprises, as reported by the Xin Hua News Agency (2022).

Despite these advancements and support mechanisms, the pace of digital transformation among SMEs in the manufacturing sector remains sluggish. A study conducted by Ma (2021) highlighted that the average level of digital transformation among SMEs in China stood at a mere 25% in 2020, with an even lower rate observed for small and medium-sized enterprises within the manufacturing industry. Consequently, extensive research efforts have been dedicated to investigating the challenges faced by SMEs during the digital transformation process, accumulating invaluable insights to guide future transformation endeavors.

Research into Small and Medium Enterprises (SMEs) has largely focused on individual-level investigations, such as single-case studies featuring exemplary SMEs (e.g., Zhang, Gao & Zhang, 2022), or examinations at the industry level, such as tourism (e.g., Dionysopoulou & Tsakopoulou, 2021). Additionally, some studies have adopted a societal perspective (e.g.,

Andrews & Zhu, 2021). However, a particularly important type of SMEs that has become a major part of China's economy are those based in manufacturing towns. These SMEs are not only integral to their respective industry ecosystems, but also act as the foundation of the local economy. This perspective remains conspicuously absent from the current body of literature on digital transformation among SMEs. Thus, there exists an urgent need to bridge this critical gap in research. By exploring the digital transformation challenges faced by SMEs within manufacturing towns, this study aims to contribute both theoretically and practically. It is hoped that this study will provide a comprehensive understanding of the unique dynamics at play within these localized ecosystems, and offer insights that can be used to inform policy decisions, guide practical strategies, and expand the knowledge base on SME digital transformation within the context of manufacturing towns in China. As such, this research is of great importance and is long overdue. The key research question that will be explored in this study: *What major obstacles do SMEs in Chinese manufacturing towns face in their digital transformation individually and collectively?*

## LITERATURE REVIEW

### Small and Medium-sized Enterprises (SMEs)

Small and medium-sized enterprises (SMEs) are companies of varying sizes, with size limitations that vary depending on the region or state (Loecher, 2000). For example, in Australia, a company is considered an SME if it has fewer than 200 employees, while in Europe the limit is set at 250 employees, and in Canada and the US, companies must have fewer than 500 employees (Krishnan and Scullion, 2017). Additionally, SMEs can be distinguished by qualitative traits, such as the focus of the company manager, with small businesses having managers primarily responsible for production or technical duties, medium businesses having managers taking on additional functions, and large companies having managers primarily responsible for business and organizational duties (Loecher, 2000). This indicates that SMEs tend to have more centralized management authority, making managers key to driving digital transformation.

Recent years have seen a surge in the growth of SMEs, which have become a major contributor to the global economy (Chung & Green, 2018). In developed countries, SMEs account for more than 90% of all businesses (Krishnan & Scullion, 2017). A survey conducted by the Organization for Economic Cooperation and Development (OECD) in 2015 revealed that SMEs make up 99% of companies in OECD and G20 nations, and are a key factor in driving economic growth (OECD, 2015). These findings emphasize the vital role of SMEs in the modern business environment, and their continued expansion has the potential to bring about positive changes in the global economy and job market.

### Business Clusters of Chinese SMEs

In China, the SMEs in clusters is a unique business model that is highly prevalent. These clusters, often referred to as characteristic towns or characteristic villages, comprise of enterprises in the same industry that are geographically close to each other and form an industrial chain. Alecke et al. (2006) suggest that an industry with similar characteristics may face increased difficulty in agglomerating due to the adverse effects of congestion. The formation of these characteristic towns in China is determined by a variety of factors.

Local resources are a key factor in the agglomeration of manufacturing industries. Maurel & Sédillot (1999) found that those relying on local materials and traditions are more likely to concentrate, such as those in the radio, television and communication equipment industries and the manufacture of rubber and plastic products, with intra-industry concentrations of 134% and 91%, respectively (Alecke et al., 2006). Additionally, China's vast rural labor force is suitable for labor-intensive manufacturing, as it is efficient and cost-effective (Lin et al., 2022). Furthermore, the close-knit rural social networks in China facilitate the formation of local clusters (Zeng et al., 2015). This, in turn, leads to an accumulation of industries and an increase in local talent, which attracts more enterprises and encourages entrepreneurship, thus creating a positive cycle. In addition, agglomeration of industries is largely driven by the advantages of close physical proximity, which facilitates collaboration, knowledge sharing and efficient supply chain management. It also promotes the exchange of ideas, encourages innovation and reduces transportation costs (Ellison, Glaeser & Kerr, 2010). Lastly, local infrastructure and support services such as transportation networks, utilities, research institutions, universities and training centers are essential to attract and maintain industry agglomeration, as they reduce costs, enhance connectivity and increase the overall competitiveness of the cluster (Ernst, 2010).

In comparison to other developing countries such as India, the e-commerce clusters in China (e.g. Taobao Villages) are more efficient due to their advanced internet access, ICT infrastructure, and logistics services in rural areas (Lin et al., 2022). Consequently, local government and related organizations' support is essential. Moreover, various conditions contribute to the emergence of industrial clusters in different areas, and a range of agglomeration forces operate at different spatial scales (Alecke et al., 2006).

According to available data, the number of characteristic towns in China is projected to reach 2,698 in 2020, spread across the country and engaging in a variety of industries such as tourism, manufacturing, and technological innovation (Prospective Industry Research Institute, 2021). In 2019, the market size of these towns was estimated to be 1,348.5 billion yuan (Sohu, 2021). The Taobao Village is a notable example of an e-commerce cluster in rural areas, with 474 villages collectively achieving annual sales of over \$100 million on AliExpress, Alibaba's cross-border e-commerce platform (Aliresearch, 2019). This form of business cluster has brought great benefits to China's e-commerce industry, as it facilitates the integration of production factors such as information, capital, technology and talent, and has generated a number of firms producing



intermediate goods, leading to increased economic income and job opportunities in the local area (Aranya, 2008). Consequently, the successful characteristic town business model has become an integral part of China's economy, owing to its considerable contributions. Characteristic towns can be classified into eight primary industries, namely tourism, healthcare, manufacturing, education, agriculture, innovation, ecommerce, logistics and science and technology (Prospective Industry Research Institute, 2021). Among these, the equipment manufacturing industry town has the longest history and is the earliest to form. Since the start of China's industrialization in the 1980s, these towns have become abundant and widespread, playing a major role in driving local economic growth (Aranya, 2008). As such, the equipment manufacturing industry town is highly representative of the other industries.

### **Equipment Manufacturing Industry**

In China, the equipment manufacturing industry is of paramount importance, providing the essential tools and machinery that enable and facilitate the operation and growth of other industrial sectors (Lin, 2004). It is the earliest form of equipment production, beginning with the production of agricultural equipment and automobiles (Li & Ouyang, 2020). As science and technology progress and society develops, the products of the equipment manufacturing industry become increasingly varied and critical. This industry encompasses the construction and mining sectors, which rely heavily on equipment, as well as the healthcare and electronics manufacturing sectors, which require sophisticated medical devices and cutting-edge semiconductor equipment, respectively (Li & Ouyang, 2020). Thus, the equipment manufacturing industry plays a pivotal role in the global economy, and is an indispensable component of industrial progress.

The equipment manufacturing sector in China has consistently held a one-third share in terms of industrial sales value. From 2011 to 2015, the sales value attributed to the equipment manufacturing sector increased from 32.69% to 34.50%. In 2017, the sector's profit volume reached a substantial CNY of 2.671.332 billion, accounting for 35.66% of the overall industrial proportion. This demonstrates the sector's significant influence on the economic gains of the entire industry. Additionally, China's equipment manufacturing industry has achieved remarkable progress in terms of technological advancement, with a series of breakthroughs in independent research and development endeavors. This has placed it among the world's leading high-performing sectors (Li et al., 2020; Li et al., 2021).

Data from the Ministry of Industry and Information Technology of People's Republic of China (MIIT) in 2017 revealed that China's manufacturing output value accounted for approximately 33% of the global total, amounting to roughly \$4.5 trillion (Shen, 2018). This study focuses on the digital transformation of the equipment manufacturing industry in a valve manufacturing town in Anhui Province, China. Valves are an integral part of fluid control systems and are used in various industries, such as oil, gas, power, chemical, metallurgical, and pharmaceutical manufacturing. The competitive landscape of the global valve industry is highly dispersed, with the top eight enterprises accounting for only 10.19% of the market share. To reduce production costs and increase competitiveness, some well-known valve manufacturers have shifted their production centers from developed nations to developing countries, such as China, India, and South Korea (Chang, Zhang & Xu, 2021). China is one of the world's largest centers for valve manufacturing, with over 3,000 valve manufacturers. Neway is the largest Chinese industrial valve manufacturer, boasting an impressive annual production capacity of 600,000 units and resulting in a total sales revenue of 2.5 billion yuan (Chang, Zhang & Xu, 2021). In comparison, a research report from 2017 reveals that less than 500 of China's valve manufacturers reported annual sales exceeding 20 million RMB, and only 17 valve companies recorded sales revenues exceeding 1 billion RMB (Chang, Zhang & Xu, 2021). As such, a vast majority of China's valve manufacturers are SMEs who form business clusters in order to gain a competitive edge in the industry. In various provinces across China, there are small and large valve manufacturing towns, which supply a range of valves and valve parts, such as valve stems, rubber rings, and flanges. Anhui alone has over ten such towns. (Bose et al., 2008).

China's valve industry has been able to capitalize on competitive pricing and shorter delivery periods, yet it is facing certain challenges due to the changing demographics and greater product precision demands. The aging population and higher levels of education have resulted in a significant rise in labor costs in China. According to research conducted by the Oxford Economic Research Institute, the wage increase of China's manufacturing labor force was found to be much higher than the growth rate of production efficiency (Huiwen, 2016). To maintain the advantages of the manufacturing sector, it is essential to consider the digital transformation of China's valve manufacturing industry. Consequently, many equipment manufacturing companies have already adopted digital transformation to various extents in their management or production departments.

### **Digital Transformation and Challenges**

The implementation of digital technologies such as automation, artificial intelligence and machine learning has revolutionized the manufacturing industry worldwide, making digital transformation a key component for sustained growth in recent times. Customers expect rapid delivery of quality products, while manufacturers seek to operate with reduced costs. As such, many manufacturers are experimenting with digital transformation to improve efficiency, such as optimizing plant performance, cutting down on maintenance costs and maximizing resource utilization (Duraivelu, 2022). Digital transformation, as defined by Fitzgerald et al. (2014), is the use of modern digital technologies - including social media, mobile technology, analytics and embedded devices - to make significant improvements in business, including improved customer experience, streamlined operations and the development of new business models. For equipment manufacturing enterprises, digital transformation can lead to improved quality and efficiency, reduced waste and costs, swift adaptation to customer demands and market changes, and the creation of innovative products and services (Duraivelu, 2022). Studies have demonstrated that the most advanced

companies in their digital transformation journey experienced a growth rate six times higher than the least mature ones (Henriette, Feki & Boughzala, 2016). Therefore, effective digital transformation can bring numerous benefits to the company.

However, there are also many challenges of digital impact that companies may encounter: (1) Significant shifts in routines and work methods, emphasizing collaboration and extensive interactions (Jones, Hutcheson & Camba, 2021; Loonam et al., 2018; Parviainen et al., 2017); (2) Employees and stakeholders showing reluctance to embrace these changes; (3) Insufficient digital skills and expertise present within the organization (Jones, Hutcheson & Camba, 2021; Loonam et al., 2018); (4) Considerable expenses associated with adopting new technologies and seamlessly integrating them with current systems (Jones, Hutcheson & Camba, 2021; Duraivelu, 2022); (5) Worries about security and privacy, focusing on data protection and cyber risks (Parviainen et al., 2017; Jones, Hutcheson & Camba, 2021; Duraivelu, 2022); (6) Challenges in effectively handling and analyzing the vast volumes of data generated by digital processes (Parviainen et al., 2017; Jones, Hutcheson & Camba, 2021; Loonam et al., 2018); and (7) The absence of a well-defined digital strategy and leadership to guide the transformation process forward (Parviainen et al., 2017). Despite the research conducted by scholars on the difficulties of digital transformation, and the solutions proposed, the specific issue of SME clustering in manufacturing towns has yet to be adequately addressed. Thus, we propose that the organization of SMEs within local town settings should be further explored, as it presents a distinctive research perspective.

### RESEARCH METHOD

This paper utilizes inductive reasoning as its chosen approach for theory development. The aim of this study is to consolidate the challenges faced by lagging SMEs in digital transformation, in order to strengthen the theoretical foundation for enterprises striving to achieve digital production and management. To achieve this, empirical data will be collected from various SMEs, followed by the organization and synthesis of this data. Inductive reasoning, as advocated by Eriksson and Kovalainen (2008), is deemed the most suitable approach for this purpose, as it offers a more comprehensive exploration of the entire spectrum of phenomena under investigation, as outlined by Doz (2011). The intention of this study is not to validate or refute existing theories, but rather to observe recurring phenomena within specific company contexts and derive specific principles that contribute to the expansion of current theory. In alignment with this research philosophy, this paper adopts the qualitative research approach of interpretivism. As a general guideline, the hermeneutic paradigm consistently employs inductive reasoning as the method for theoretical development, as supported by Saunders et al. (2012, p. 145).

This research focuses on a manufacturing town in China, examining the challenges faced during the digital transformation process. Due to the lack of existing data and studies in this area, primary data must be collected directly from the original sources, as recommended by Collis and Hussey (2014). To this end, a semi-structured interview approach was deemed the most appropriate method. This approach provides structure and flexibility, allowing for a set of open-ended questions while ensuring coverage of predetermined key themes or topics. As Tegan (2022) explains, semi-structured interviews yield comparable and reliable data, as well as a relaxed and flexible conversational atmosphere, which facilitates the acquisition of valuable and trustworthy information.

This research utilized a two-tiered selection process for participants. Firstly, a number of leading enterprises located in a well-known manufacturing town, China, will be chosen as the focus of the study due to their active or recent involvement in digital transformation initiatives. Secondly, the owners and general managers of these companies will be invited to participate in the study. This is deemed necessary as these individuals possess a deep understanding of all facets of their respective companies, and the authority to enact digital transformation changes. As a result, the owners and general managers are identified as the primary interviewees.

This study will utilize Grounded Theory as the method for analyzing the collected data, with the aim of identifying common laws and theories related to the digital transformation of enterprises in Chinese manufacturing towns. Grounded Theory is a qualitative research approach that involves exploring real-world data to construct theories, rather than relying on the analysis and integration of existing data (O’Gorman & MacIntosh, 2014). This method emphasizes the development of theories from systematically collected and analyzed data, where data collection, analysis, and resulting theory are closely linked (Bell, Bryman & Harley, 2022). Grounded Theory is particularly beneficial in cases where the field is relatively unknown or lacks well-established theoretical foundations (Bell, Bryman & Harley, 2022), making it the optimal choice for this study.

The grounded theory approach is an important component of qualitative data analysis, consisting of three primary stages: open coding, axial coding, and selective coding. Open coding is the first step of this process, which entails breaking down the data into distinct components and assigning labels to them. Axial coding follows, which involves categorizing the data into meaningful categories and establishing relationships between the codes. Finally, selective coding unites all the categories by focusing on a central core category. This core category serves as an organizing theme, providing a comprehensive understanding of the research phenomenon. This study aims to use these three coding steps to identify the consistent challenges faced by SMEs in manufacturing towns during their digital transformation journeys.

### EXPECTED OUTCOMES

The anticipated outcome of this research is multifaceted and includes the following: (1) Identification of key challenges: This research aims to pinpoint and document the major difficulties faced by SMEs in Chinese manufacturing towns while they go

through digital transformation. This will comprise a thorough analysis of the individual and communal issues encountered by those enterprises. (2) Theoretical contributions: This research will be instrumental in constructing a comprehensive theoretical framework that comprehends the distinctive characteristics and intricacies of digital transformation in localized settings such as manufacturing towns. It will serve as a basis for forthcoming studies in this field, granting a more profound comprehension of SME digital transformation. (3) Policy references: This study is anticipated to provide invaluable perspectives that can guide policy choices focused on aiding SME digital transformation in manufacturing towns. Governmental entities and policymakers can take advantage of this research to devise more efficient plans and support systems. (4) Practical implications: This research will provide practical implications for those involved in digital transformation initiatives, such as SME owners, managers, and stakeholders. The results of the study will enable them to tackle the challenges more effectively and make sound decisions throughout the transformation process. (5) Expansion of knowledge base: This research aims to broaden the existing understanding of digital transformation among SMEs in manufacturing towns in China. By investigating an under-researched topic, it will contribute to the existing literature, providing both academics and practitioners with a more comprehensive understanding.

#### ACKNOWLEDGMENT

We would like to express our sincere appreciation to the companies that contributed to this project, including Qingyang Xingxiang Machinery Factory, Anhui Fangxing Industrial CO., LTD., Anhui Zhonghui Parts manufacturing Co., LTD, Chizhou CIIC Valve Technology CO.,LTD, CIIC Valve CO., LTD, Houding Packaging Co., Ltd, Anhui Green Rubber Plastic Products Co.,Ltd, Qing Yang Lewang Accessories Manufacturing CO., LTD, and Chizhou Sun Rising Valve & Pipe Fitting CO., LTD. Additionally, this work was partially supported by the Lancaster University Management School MSc in Management (MiM) Programme MiM Research Scholarship.

#### REFERENCES

- Alecke, Alsleben, C., Scharr, F., & Untiedt, G. (2006). Are there really high-tech clusters? The geographic concentration of German manufacturing industries and its determinants. *The Annals of Regional Science*, 40(1), 19–42.
- Aliresearch. (2021). Research report on Taobao Villages in China (2020). Aliresearch. <http://www.aliresearch.com/en/Reports/Reportsdetails?articleCode=167153834769125376>
- Aranya, R. (2008). Location Theory in Reverse? Location for Global Production in the IT Industry of Bangalore. *Environment and Planning A: Economy and Space*, 40(2), 446–463.
- Bell, E., Bryman, A., & Harley, B. (2022). *Business research methods* (6th ed.). Oxford University Press.
- Bose, I., Pal, R., & Ye, A. (2008). ERP and SCM systems integration: The case of a valve manufacturer in China. *Information & Management*, 45(4), 233-241.
- Chang, V., Xu, Y.K., Zhang, J., & Xu, Q. (2021). Research on intelligent manufacturing development approach for China's local valve industry. *Smart and Sustainable Built Environment*, 10(2), 293-321.
- Chung, K. L., & Green, N. A. (2018). Talent Management Practices in Small- and Medium-sized Enterprises in the Hospitality Sector: An Entrepreneurial Owner-manager Perspective. *Worldwide Hospitality and Tourism Themes*, 10(1), 101–116.
- Collis, J., & Hussey, R. (2014). *Business Research: A practical guide for undergraduate & postgraduate students* (4th ed.). Palgrave Macmillan, UK.
- Doz, Y. (2011). Qualitative research for international business. *Journal of International Business Studies*, 42(5), 582-590.
- Duraivelu, K. (2022). Digital transformation in manufacturing industry—A comprehensive insight. *Materials Today: Proceedings*, 68, 1825-1829.
- Economic Daily. (2021). How China's manufacturing industry ranks first in the world? Central People's Government of the People's Republic of China. [https://www.gov.cn/xinwen/2021-09/22/content\\_5638605.htm](https://www.gov.cn/xinwen/2021-09/22/content_5638605.htm)
- Ellison, G., Glaeser, E.L., & Kerr, W.R. (2010). What causes industry agglomeration? Evidence from coagglomeration patterns. *American Economic Review*, 100(3), 1195-1213.
- Ernst, D. (2010). Upgrading through innovation in a small network economy: Insights from Taiwan's IT industry. *Economics of Innovation and New Technology*, 19(4), 295-324.
- Eriksson, P., & Kovalainen, A. (2008). *Qualitative Methods in Business Research*. SAGE Publications Ltd. <https://www.doi.org/10.4135/9780857028044>
- Fitzgerald, M., Kruschwitz, N., Bonnet, D., & Welch, M. (2014). Embracing digital technology: A new strategic imperative. *MIT Sloan Management Review*, 55(2), 1.
- Geng, D., Lai, K.H., & Zhu, Q. (2021). Eco-innovation and its role for performance improvement among Chinese small and medium-sized manufacturing enterprises. *International Journal of Production Economics*, 231, 107869.
- Henriette, E., Feki, M., & Boughzala, I. (2016). Digital transformation challenges. <https://aisel.aisnet.org/mcis2016/33/>
- Huiwen, F. (2016). *Hot Topics and Forecast on the Trends of Global Manufacturing*. Beijing Posts and Telecom Press, Beijing.
- Jones, M.D., Hutcheson, S., & Camba, J.D. (2021). Past, present, and future barriers to digital transformation in manufacturing: A review. *Journal of Manufacturing Systems*, 60, 936-948.
- Krishnan, T., & Scullion, H. (2017). Talent Management and Dynamic View of Talent in Small and Medium Enterprises. *Human Resource Management Review*, 27(3), 431–441.
- Lin, J., Li, H., Lin, M., & Li, C. (2022). Rural e-commerce in China: Spatial dynamics of Taobao Villages development in Zhejiang Province. *Growth and Change*, 53(3), 1082-1101.
- Lin, B.W. (2004). Original equipment manufacturers (OEM) manufacturing strategy for network innovation agility: the case of Taiwanese manufacturing networks. *International Journal of Production Research*, 42(5), 943-957.

- Li, W., & Ouyang, X. (2020). Investigating the development efficiency of the green economy in China's equipment manufacturing industry. *Environmental Science and Pollution Research*, 27, 24070-24080.
- Li, Y., Zhang, H., Liu, Y., & Huang, Q. (2020). Impact of embedded global value chain on technical complexity of industry export—An empirical study based on China's equipment manufacturing industry panel. *Sustainability*, 12(7), 2694.
- Li, Y., Wu, Y., Chen, Y., & Huang, Q. (2021). The influence of foreign direct investment and trade opening on green total factor productivity in the equipment manufacturing industry. *Applied Economics*, 53(57), 6641-6654.
- Loonam, J., Eaves, S., Kumar, V., & Parry, G. (2018). Towards digital transformation: Lessons learned from traditional organizations. *Strategic Change*, 27(2), 101-109.
- Loecher, U. (2000). Small and medium-sized enterprises—delimitation and the European definition in the area of industrial business. *European Business Review*, 12(5), 261-264.
- Parviainen, P., Tihinen, M., Kääriäinen, J., & Teppola, S. (2017). Tackling the digitalization challenge: how to benefit from digitalisation in practice. *International journal of information systems and project management*, 5(1), 63-77.
- Prospective Industry Research Institute (2021). Industry depth! An article to learn more about the market status, competition pattern and development trend of the Chinese characteristic town industry in 2021. <https://bg.qianzhan.com/trends/detail/506/210621-3827f7a0.html>
- Ma, N. N. (2021). Only 25% of China's SMEs undergo digital transformation. How to speed up supply-side digitisation? *Southern Metropolis Daily*. <https://new.qq.com/rain/a/20210428A0FKYD00#>
- Maurel, F., & Sédillot, B. (1999). A measure of the geographic concentration in French manufacturing industries. *Regional Science and Urban Economics*, 29(5), 575-604.
- OECD (2015). *Taxation of SMEs in OECD and G20 countries*. OECD tax policy studies no.23, Paris.
- Saunders, M.N.K., Lewis, P., & Thornhill, A. (2012). *Research Methods for Business Students*. Pearson Education UK.
- Shen, R. (2018). Expanding the SCO development path and promoting international capacity cooperation. *China Science and Technology Forum*, 2018(11), 189.
- Sohu (2021). The development status of China's characteristic town industry in 2020, and the government's planned investment will further increase. [https://www.sohu.com/a/461091605\\_120113054](https://www.sohu.com/a/461091605_120113054)
- Tegan G. (2022). Semi-Structured Interview | Definition, Guide & Examples. Scribbr. <https://www.scribbr.com/methodology/semi-structured-interview/>
- O'Gorman, K.D., & MacIntosh, R. (2014). *Research Methods for Business and Management: A Guide to Writing Your Dissertation* (2nd ed.). Goodfellow Publishers, Oxford.
- Xin Hua News Agency (2022). Do a good job in digital "addition and subtraction", and policies help small and medium-sized enterprises to transform intelligently. [https://www.gov.cn/zhengce/2022-11/11/content\\_5726145.htm](https://www.gov.cn/zhengce/2022-11/11/content_5726145.htm)
- Zeng, Y., Qiu, D., Shen, Y., & Guo, H. (2015). Study on the formation of Taobao Village: Taking Dongfeng Village and Junpu Village as examples. *Economic Geography*, 35(12), 90-97.
- Zhang, X., Gao, C., & Zhang, S. (2022). The niche evolution of cross-boundary innovation for Chinese SMEs in the context of digital transformation—Case study based on dynamic capability. *Technology in Society*, 68, 101870.
- Dionysopoulou, P., & Tsakopoulou, K. (2021). Policy responses to critical issues for the digital transformation of tourism SMEs: Evidence from Greece. In *Culture and Tourism in a Smart, Globalized, and Sustainable World: 7th International Conference of IACuDiT*, Hydra, Greece, 2020 (pp. 499-510). Springer International Publishing.
- Andrews, H., & Zhu, R. (2021). Revisiting the Determinant Factors of E-Commerce Adoption in the Wake of the Pandemic: The New Landscape of Digital Transformation for SMEs in North West UK. *ACIS 2021 Proceedings*, 70.

# Unveiling the Potential and Pitfalls of ChatGPT: A Comprehensive Analysis and Ethical Exploration

Josefina Y.-C. Hong<sup>1,\*</sup>

\*Corresponding author

<sup>1</sup> HEC Liège Executive Education, Management School-Liège Université, Liège, Belgium, Executive Doctorate in Business Administration, EDDBA Student, hongjosefina@gmail.com

## ABSTRACT

ChatGPT, an advanced language model, was launched by the Open AI team in November 2022 and quickly gained popularity, significantly enhancing people's awareness of the evolution and future impacts of Artificial Intelligence (AI). This paper aims to delve into the multifaceted landscape of ChatGPT, with the objective of thoroughly analyze its capabilities, potential applications, limitations, and ethical considerations. In a world increasingly reliant on AI-driven communication, understanding ChatGPT's impact becomes crucial. This paper empirically analyzed cases from the literatures and this study hopes to provide contribution to the ongoing discourse surrounding and their integration into various sectors.

*Keywords:* ChatGPT, Open AI, AI technologies, Artificial Intelligence (AI)

## 1. INTRODUCTION

In the 21st century, the field of artificial intelligence (AI) has borne witness to remarkable advancements, reshaping the landscape of technology, communication, and human-machine interactions. Artificial intelligence (AI) has emerged as a transformative force with the potential to redefine human interactions, streamline industries, and revolutionize the way we live and work. Among the myriad manifestations of AI, the development of chatbots powered by sophisticated language models like GPT (Generative Pre-trained Transformer) has garnered significant attention. These ChatGPT systems have the ability to generate human-like text and engage in dynamic conversations, making them increasingly prevalent in a wide range of applications, from customer service and healthcare to content generation and education. It seems to unlock a myriad of possibilities across various domains.

They hold the promise of enhancing efficiency, accessibility, and convenience in our digital age.

Yet, as we embark on this transformative journey, it becomes increasingly imperative to critically examine the potential and pitfalls of these ChatGPT systems. While they offer tremendous opportunities for improving our lives, they also raise profound ethical and societal concerns. This dissertation, titled "Unveiling the Potential and Pitfalls of ChatGPT: A Comprehensive Analysis and Ethical Exploration," aims to illuminate the multifaceted landscape of ChatGPT, shedding light on its capabilities, limitations, and ethical dimensions.

### 1.1 Motivation

The motivation for this dissertation stems from the recognition that as AI-powered chatbots become increasingly integrated into our daily lives, it is imperative to understand the multifaceted nature of these systems. While ChatGPT systems hold the promise of enhancing productivity, accessibility, and convenience, they also raise concerns related to bias, misinformation dissemination, privacy infringements, and accountability. Addressing these concerns is paramount to ensuring the responsible use of AI technology.

### 1.2 Objects

The primary objectives of this dissertation are as follows:

1. Through an in-depth analysis of previous literature, we delve into ChatGPT, exploring the potential and prospects of ChatGPT technology across various applications, highlighting its transformative power and real-world benefits.
2. To identify the pitfalls and challenges associated with ChatGPT, including issues related to bias, misinformation, and security.
3. To delve into the ethical considerations surrounding ChatGPT, addressing concerns such as fairness, transparency, and the impact on vulnerable populations.

4. To examine existing regulatory and policy frameworks governing AI and chatbots and assess their effectiveness in ensuring responsible deployment.

### 1.3 Structure of the Dissertation

This dissertation is structured into several chapters that systematically delve into the complexities of ChatGPT technology. The subsequent chapters will provide a comprehensive analysis, combining insights from literature, case studies, and ethical frameworks. We will begin by reviewing the existing literature on GPT models and chatbots, and meanwhile explore their potential in Chapter 2 and then address the pitfalls, challenges and limitations of ChatGPT in Chapter 3. Chapter 4 will navigate the intricate ethical considerations. Finally, Chapter 5 will provide recommendations based on the analysis and offer a concluding perspective on the broader implications of this research.

## 2. LITERATURE REVIEW

The development and deployment of ChatGPT, powered by advanced language models like GPT-3.5, stand at the intersection of artificial intelligence and human-computer interaction. This section provides a comprehensive review of the existing literature to contextualize the research on ChatGPT, examining its evolution, applications, and ethical considerations.

### 2.1 Evolution of ChatGPT Technology

The landscape of artificial intelligence (AI) has been dramatically reshaped by the emergence of powerful language models such as GPT (Generative Pre-trained Transformer). ChatGPT technology represents the latest iteration of natural language processing (NLP) advancements. While early chatbots relied on rule-based systems, recent developments have harnessed the power of deep learning and transformer-based models like GPT. These models, pre-trained on vast text corpora, enable chatbots to generate coherent and contextually relevant responses, thus bridging the gap between human and machine communication (Brown et al., 2020).

ChatGPT is a branch of the broader GPT model family that has received much attention in recent years (Brown et al., 2020). The evolution of GPT models represents a significant milestone in natural language processing. We explore seminal works that have contributed to the development of GPT, tracing its lineage from GPT-1 to the most recent iterations. This section aims to elucidate the capabilities and limitations of these models, setting the stage for the examination of ChatGPT in subsequent sections. Here is an overview of the key milestones in the development of ChatGPT technology:

#### 1. Introduction of GPT Models:

- The foundation for ChatGPT models was laid with the introduction of the GPT (Generative Pre-trained Transformer) architecture. GPT-1, developed by Open AI, marked the beginning of large-scale transformer-based language models. It demonstrated the potential of pre-training on vast amounts of text data followed by fine-tuning for specific tasks.

#### 2. Emergence of GPT-2:

- GPT-2, introduced in 2019, gained widespread attention due to its impressive text generation capabilities. It was notable for its ability to generate coherent and contextually relevant text, raising concerns about potential misuse. Initially, Open AI withheld the full release due to these concerns but later made it available to the public.

#### 3. Scaling Up with GPT-3:

- GPT-3, released in 2020, represented a significant leap in scale and performance. It featured 175 billion parameters, making it one of the largest language models at the time. GPT-3 demonstrated remarkable proficiency in a wide range of language tasks, including translation, question answering, and chatbot conversations. It could generate human-like responses and engage in multi-turn dialogues, setting the stage for ChatGPT.

#### 4. Birth of ChatGPT Models:

- The development of ChatGPT models specifically tailored for conversational applications followed the success of GPT-3. Researchers and organizations began fine-tuning GPT-3 and similar models to excel in dialogue generation and chatbot applications. This resulted in models capable of engaging in coherent and contextually relevant conversations with users.

GPT-3 is the most powerful language model ever, and compared to its predecessor, GPT-2, GPT-3 represents a tremendous leap. This model has 175 billion parameters (values that the neural network attempts to optimize during training), while GPT-2 had only 1.5 billion parameters. Indeed, when it comes to language models, size does matter (Heaven, 2020).

GPT-3 has set new benchmarks in conversational AI. Open AI's release of GPT-3 has spurred widespread interest and experimentation, with developers and organizations integrating it into a multitude of applications, from virtual assistants to content generation (Amodei et al., 2019). The growing ecosystem around ChatGPT underscores its potential to reshape industries and redefine user experiences.

### 5. Latest Milestones with GPT-4:

- GPT-4, the latest milestone in OpenAI's effort in scaling up deep learning. GPT-4 is a large multimodal model. The features of GPT-4 are to possess image interpretation capabilities, exhibit enhanced reasoning skills and can handle content as long as 25,000 words, which is more than eight times what ChatGPT is currently capable of processing, demonstrating superior performance in terms of text generation length and capacity. (OpenAI, 2023)

GPT-4 is expected to have a higher number of parameters compared to GPT-3, along with a larger volume of training data. This will enable GPT-4 to have a better understanding of and generate natural language more accurately and fluently. While less capable than humans in many real-world scenarios, it exhibits human-level performance on various professional and academic benchmarks.

## 2.2 Potential applications of ChatGPT

The versatility of ChatGPT technology is reflected in its broad range of applications. Here we introduce the applications to understand the development of ChatGPT in various fields at present.

### 1. Healthcare Chatbots:

- In the healthcare sector, ChatGPT can be used to create virtual health assistants that answer medical queries, schedule appointments, and provide health information (S. Anikina et al. 2019)
- ChatGPT systems aid in symptom checking and medical information dissemination, enhancing accessibility to healthcare resources (Gupta et al., 2020).
- ChatGPT can provide information on public health issues, such as infectious diseases, chronic diseases, and environmental health hazards, also it can answer questions about health promotion and disease prevention strategies and provide examples. ChatGPT can provide information about the types of community health programs and services available, the populations they serve, and the specific health outcomes they aim to achieve (Biswas, 2023)
- The integration of AI and online therapy research is a crucial direction for optimizing online therapy. One possible solution is to incorporate artificial intelligence in the form of conversational agents into the platform. (Ly et al., 2017; Morris et al., 2018) Its function is to play the role of a tutor or a psychotherapist who directly assists clients in analyzing negative automatic thoughts or maladaptive core beliefs.

### 2. Virtual Assistants:

- ChatGPT can serve as the underlying technology for virtual assistants, providing users with the ability to interact naturally and perform tasks like setting reminders, answering questions, and controlling smart home devices (Apple, 2021).

### 3. Language Translation:

- ChatGPT can be employed for real-time language translation services, making it easier for users to communicate across language barriers (Johnson et al., 2017).

### 4. Content Generation:

- ChatGPT models are used to automate content generation, including writing articles, generating marketing copy, and creating product descriptions (Forbes, 2021).

### 5. Customer Support Chatbots:

- ChatGPT can be employed as a virtual customer support agent, offering assistance and answering queries. These chatbots can provide good support and handle a variety of customer inquiries (IBM, 2020)
- In customer service, chatbots equipped with GPT models have demonstrated the ability to handle routine inquiries, leading to improved response times and customer satisfaction (Chen et al., 2021).
- Online retailers can use ChatGPT-powered chatbots to assist customers with product recommendations, order tracking, and general inquiries, enhancing the overall shopping experience (Duraisamy & Ganapathy, 2020).

### 6. Educational Chatbots:

- ChatGPT can be applied in education to create virtual tutors and learning companions. These chatbots can assist students with homework, answer questions, and provide explanations (M. Hendrix et al., 2019).
- ChatGPT has found applications in education, where it supports personalized learning experiences (Makhmutov et al., 2020) and content generation, automating the creation of text for various purposes (Raffel et al., 2019).
- ChatGPT can act as virtual tutors, assisting students with homework, providing explanations, and facilitating learning (Zhang et al., 2020).

### 7. Writing Assistance:

- Writers and content creators can use ChatGPT to assist with brainstorming ideas, improving writing quality, and generating creative content (Harvard Business Review, 2021).



- Many teachers unanimously agree that artificial intelligence writing tools have positively enhanced students' writing quality, particularly improving their content and organizational quality (Marzuki et al., 2023)

#### **8. Legal and Financial Advising:**

- ChatGPT models can provide basic legal and financial advice, offering information on legal procedures, financial planning, and investment strategies (McKinsey & Company, 2020).

#### **9. Game NPCs and Dialogue:**

- In video game development, ChatGPT can be used to create non-player characters (NPCs) with advanced dialogue systems, enhancing the gaming experience (D. Cavazza et al., 2014).

The emergence of ChatGPT signifies a shift in artificial intelligence from data understanding to data generation, achieving a leap from machine perception to machine creation. ChatGPT, by learning and understanding human intentions in generating content through dialogue, assists humans in accomplishing a range of tasks. From an academic perspective, ChatGPT represents a significant milestone in the field of artificial intelligence, revealing the potential for achieving general artificial intelligence. From an industry standpoint, ChatGPT has proven to be a valuable tool in various sectors that heavily rely on human-generated knowledge, such as IT, customer service, entertainment, education, and healthcare. Essentially, ChatGPT is a rapid content generation tool, enabling low-cost or even zero-cost automated content creation, fundamentally transforming content production models across industries. ChatGPT has a wide range of potential applications and can play a crucial role in almost any field that requires the processing and understanding of natural language. With continuous technological development and innovation, the impact and applications of ChatGPT will continue to expand and deepen.

### **3. PITFALLS, CHALLENGES AND LIMITATIONS OF CHATGPT**

ChatGPT, like any advanced AI language model, comes with its fair share of pitfalls, challenges, and limitations. Here are some of the key ones:

#### **Bias and Fairness:**

- Pitfall: ChatGPT models can produce biased or unfair responses due to biases in their training data.
- Limitation: Ensuring fairness and mitigating bias in generated content is an ongoing challenge.

#### **Inaccurate Information:**

- Pitfall: ChatGPT models may generate responses that are factually incorrect or misleading.
- Limitation: These models lack real-time fact-checking abilities, making it challenging to verify information

#### **Contextual Understanding:**

- Pitfall: ChatGPT models may struggle with maintaining context in lengthy conversations and may provide responses that seem out of place.
- Limitation: Improving contextual understanding in dynamic conversations is a challenging task.

#### **Generating Harmful Content:**

- Pitfall: ChatGPT models can generate harmful or inappropriate content, including hate speech or offensive language.
- Limitation: Implementing effective content moderation to prevent harmful output is crucial.

#### **Over-reliance on Prompts:**

- Pitfall: Users often need to provide clear and well-structured prompts to get meaningful responses, limiting the model's ability to handle vague or ambiguous queries.
- Limitation: Enhancing the model's ability to generate contextually relevant responses without specific prompts is challenging.

#### **Difficulty in Handling Ambiguity:**

- Pitfall: Ambiguous questions or those with multiple interpretations can lead to incorrect responses.
- Limitation: Resolving ambiguity in language is a complex task that remains a challenge.

#### **Lack of Common Sense and World Knowledge:**

- Pitfall: ChatGPT models may lack common sense reasoning abilities and may not have access to up-to-date world knowledge.

- Limitation: Integrating external knowledge sources and improving general knowledge is an ongoing area of research.

#### **Resource Intensiveness:**

- Pitfall: Training and deploying large-scale ChatGPT models can be resource-intensive, limiting accessibility.
- Limitation: Reducing resource requirements while maintaining model performance is a goal for further development.

Addressing these pitfalls and limitations is an ongoing challenge, and it requires a combination of research, responsible AI development practices, and collaboration among developers, researchers, and regulatory bodies to ensure the responsible and ethical use of ChatGPT technology.

### **4. NAVIGATE THE ETHICAL CONSIDERATIONS**

Navigating the intricate ethical considerations associated with AI technologies like ChatGPT requires a thoughtful and comprehensive approach. Here are steps and strategies to help guide this process:

#### **Ethical Frameworks and Guidelines:**

- Adopt established ethical frameworks and guidelines for AI development, such as the Asilomar AI Principles, IEEE Ethically Aligned Design, or OpenAI's own ethical guidelines.

#### **Continuous Ethics Assessment:**

- Regularly assess the ethical implications of your AI system throughout the development process. Conduct ethics reviews and audits.

#### **Transparency and Explainability:**

- Ensure that your AI system is transparent and that its decision-making processes are explainable. Users should understand why the system makes certain recommendations or decisions.

#### **Privacy by Design:**

- Embed privacy considerations into the design and development of your AI system. Implement privacy-enhancing technologies and data protection measures.

#### **Consent and Control:**

- Give users control over their interactions with AI systems. Obtain informed consent for data usage and clearly communicate how user data is handled.

#### **Social and Ethical Impact Assessment:**

- Conduct assessments of the social and ethical impact of your AI system. Consider its broader implications on society and individuals.

#### **Accountability:**

- Clearly define accountability for the behavior and output of AI systems. Developers and organizations should take responsibility for their technology.

Actually navigating the intricate ethical considerations surrounding AI technologies like ChatGPT requires ongoing diligence and a commitment to responsible AI development and deployment. By taking a proactive and ethical approach, you can help ensure that AI systems are designed and used in ways that benefit society while minimizing potential harm.

### **5. RECOMMENDATIONS**

Based on the analysis of ChatGPT and its various dimensions, here are recommendations and a concluding perspective on the broader implications of ChatGPT:

#### **Recommendations:**

##### ***Ethical Development and Auditing:***

- Developers should prioritize the ethical development of AI models like ChatGPT. Regularly audit and assess the model for biases, harmful outputs, and fairness. Actively work to reduce biases in both data and model behavior.

##### ***Transparency and Accountability:***

- Emphasize transparency in AI interactions. Clearly communicate to users when they are interacting with AI. Implement mechanisms for user feedback and hold developers and organizations accountable for AI-generated content.

##### ***Privacy and Data Security:***

- Implement robust data privacy measures. Limit data retention, obtain informed consent from users for data usage, and ensure strong data security practices, including anonymization.

**Responsible Use and Education:**

- Promote responsible AI use, especially in critical domains like healthcare, legal, and financial advising. Provide users with education about the nature of AI interactions, including limitations and potential ethical challenges.

**Collaboration and Regulation:**

- Collaborate with diverse stakeholders, including researchers, policymakers, industry experts, and the public, to collectively address ethical concerns. Advocate for ethical AI guidelines and regulations at national and international levels.

**6. CONCLUDING PERSPECTIVE**

ChatGPT and similar AI models represent a transformative step in natural language processing and have the potential to revolutionize various industries. However, their broader implications are multifaceted and require careful consideration.

The responsible development and deployment of ChatGPT are essential to harness its potential while mitigating ethical challenges. These AI models can empower businesses, enhance communication, and streamline various processes. However, they also necessitate ongoing audits, transparency, and ethical oversight to ensure that they are used safely and ethically.

In conclusion, ChatGPT is a remarkable tool with the potential to bring significant benefits. By following ethical guidelines, investing in responsible development, and fostering collaboration among stakeholders, we can navigate the challenges and implications of AI technology. Ultimately, the responsible use of ChatGPT will play a pivotal role in shaping the future of AI and its impact on society.

**REFERENCES**

- Apple. (2021). Siri: A Translation and Speech Recognition Assistant.
- Biswas, S. S. (2023). Role of Chat GPT in Public Health. *Annals of Biomedical Engineering*, 51(5), 868–869. <https://doi.org/10.1007/s10439-023-03172-7>
- Cavazza, D., et al. (2014). Dialogue Systems for Interactive Fiction Games.
- Duraisamy, & Ganapathy. (2020). AI Chatbots in E-commerce: A Comprehensive Review.
- Forbes. (2021). How AI Is Transforming Content Marketing.
- Gupta, S., & Chen, Y. (2022). Supporting inclusive learning using chatbots? A chatbot-led interview study. *Journal of Information Systems Education*, 33(1), 98–108.
- Harvard Business Review. (2021). How AI Can Help You Write Better.
- IBM. (2020). Building Chatbots and Conversational Experiences in Customer Service.
- Imran, N., Hashmi, A., & Imran, A. (2023). Chat GPT: Opportunities and Challenges in Child Mental Healthcare. *Pakistan Journal of Medical Sciences*, 39(4). <https://doi.org/10.12669/pjms.39.4.8118>
- Johnson, M. (2016). Google's Multilingual Neural Machine Translation System: Enabling Zero-Shot Translation. *arXiv.org*. <https://arxiv.org/abs/1611.04558>
- Ly, K. H., Ly, A. M., & Andersson, G. (2017). A fully automated conversational agent for promoting mental well-being: A pilot RCT using mixed methods. *Internet Interventions*, 10, 39–46. <https://doi.org/10.1016/j.invent.2017.10.002>
- Marzuki, Widiati, U., Rusdin, D., Darwin, & Indrawati, I. (2023). The impact of AI writing tools on the content and organization of students' writing: EFL teachers' perspective. *Cogent Education*, 10(2). <https://doi.org/10.1080/2331186x.2023.2236469>
- McKinsey & Company. (2020) AI in Finance: The Road Ahead.
- Hendrix, M., et al. (2019). The Rise of Educational Chatbots: A Review of their Research and Design.
- Neil Patel. (2020). Content Marketing Strategy: A Comprehensive Guide to Content Creation.
- OpenAI. (2023). *GPT-4 Technical Report*. *arXiv.org*. <https://arxiv.org/abs/2303.08774>
- Yang, A. C. M., Chen, I. Y. L., Flanagan, B., & Ogata, H. (2021). Automatic generation of cloze items for repeated testing to improve reading comprehension. *Educational Technology & Society*, 24(3), 147–158.
- Zhang, et al. (2020). Chatbots in Higher Education: A Review of Recent Progress, Challenges, and Opportunities.

## Will ChatGPT Remodify the Education? The Future of Business Education and Research

Zhan Zhan <sup>1</sup>  
A B M Munibur Rahman <sup>2,\*</sup>  
Ruichen Cui <sup>3</sup>

\*Corresponding author

<sup>1</sup> Associate Professor, Business School, Wuchang University of Technology, Wuhan, PR China. robbiezhan@hotmail.com

<sup>2</sup> Associate Professor, Business School, Wuchang University of Technology, Wuhan, PR China. abmmrahman@wut.edu.cn

<sup>3</sup> Lecturer, Business School, Wuchang University of Technology, Wuhan, PR China. crcrachel@outlook.com

### ABSTRACT

Artificial intelligence (AI) technologies have become widely used recently, upending several industries. One of the most extensively disrupted businesses today, the educational sector, is being transformed by ChatGPT. This study aims to comprehend how students feel about influencing elements and their attitudes toward novel concepts like ChatGPT. We received almost 162 respondents from the students of different business schools in the pilot survey. There are 14 questions in the questionnaire and the scales are based on the ABC model of attitudes on a Likert scale, which measures levels of attachment, propensity for behavior, and level of cognition. Investigations on study habits usually concentrate on the number of writing assignments, characteristics of information searching and selecting behaviors, and capacity for adjusting to new technology. In this research, we studied how ChatGPT may transform business education by altering how business professionals and students interact with and take in knowledge. The future of business education may be greatly changed by ChatGPT. The summary of this study offers a glimpse of how ChatGPT might revolutionize business education while also noting that doing so fully would take careful planning, ethical consideration, and steadfast study.

*Keywords:* ChatGPT, Business-education, Behavior, Attitude, Self-efficacy.

### INTRODUCTION

On 30th November 2022, ChatGPT, a new large language model-based chatbot released by an American artificial intelligence research laboratory- OpenAI, hit the Internet. (Floridi & Chiriatti, 2020), ChatGPT has attracted more than millions of users in just five days after its launch. ChatGPT can generate a more natural and realistic response to users' inputs and it allows users to chat with it about everything. ChatGPT's characteristics of questioning, recognizing ignorance, supporting multi-turn conversations, and contextual understanding attracted great and widespread attention in the academic world. According to Stokel-Walker (2023), ChatGPT can be described as a large language model (LLM) that creates convincing phrases by imitating the linguistic statistical patterns seen in a sizable body of literature gathered from the internet. With its ability to respond to a variety of themes and subjects, ChatGPT could be a helpful tool for chatbots, academia, customer support, and a variety of other applications (Gilson et al., 2023). Consequently, the platform has gained a lot of attention from early adopters (e.g. students and scholars) and has even been termed a disruptive technology in some sectors (Haqee et al., 2022), including academia and education.

The introduction of ChatGPT, a generative AI platform created by OpenAI, has generated a lot of buzz in the academic and K-12 communities, as well as in the business world. ChatGPT, which follows the GPT-4 paradigm as previously stated (Vanian, 2022), draws upon a large corpus of internet-sourced language patterns to generate text that is both compelling and well-suited to its context (Stokel-Walker, 2023). Chatbots, customer service, and academic research may all benefit from it because of how well it handles a wide range of topics and concepts (Gilson et al., 2023). The influence of ChatGPT on the quality and quantity of academic research is of particular concern (Stokel-Walker, 2023) and has reverberated across fields, including tourism and hospitality.

However, the benefits of ChatGPT in both classroom instruction and scientific inquiry should not be disregarded (Anders, 2022). It helps level the playing field when it comes to educational resources and the ability to tailor one's education to suit individual needs. ChatGPT's potential to foster critical thinking and increase AI literacy among educators and students is immense when used properly. It's also a great way to get students excited about learning.

Authorship credits on preprints and published papers attest to ChatGPT's impact on the scientific community (Stokel-Walker, 2023). Editors and publishers of academic journals, as well as the academic community at large, continue to dispute whether or not it is proper to include artificial intelligence programs like ChatGPT as authors.

The larger context of AI's effect on the job market and education (AI's influence on society), expands on the impact of AI in education. Academic writing, programming, and the arts are just some of the mundane and creative activities that AI may replace, highlighting the importance of education in equipping the next generation with the necessary skills and competence (Li, Y., Choi; Science, 2022). The development of AI-driven systems such as ChatGPT shows AI's contributions to automation and creativity via its expertise in natural language processing and creative activities. With its groundbreaking artificial intelligence technology, ChatGPT has the potential to revolutionize several industries, including the travel and hotel industries. While potentially beneficial in terms of accessibility and customization, its disruptive character threatens established academic standards. Integrating technology into the academic world, however, has ethical and intellectual ramifications that are still being debated and investigated.

Some researchers believe that ChatGPT will accelerate education transformation as it could be a powerful educational tool under proper use. While some researchers believe that if ChatGPT becomes a strong tool for cheating, abusing ChatGPT will not only have adverse impacts on academic fairness but directly threaten academic ethics. Therefore, facing new challenges of ChatGPT, this paper intends to investigate business students' attitudes and perceptions towards ChatGPT to effectively understand the challenges of ChatGPT to business education with appropriate solutions.

## **CHATGPT IN REGARDS OF BUSINESS EDUCATION**

The practicality of ChatGPT is one of its most alluring features, and it has had a significant impact on the field of business education. Conversational agent powered by artificial intelligence that can mimic interactions with clients, gather market data, and evaluate business trends for use in the classroom. Future business professionals will be better equipped to deal with the complexity of the corporate world after having had this kind of hands-on experience.

### **I. Content Generation**

Content generating function means ChatGPT can automatically generate text. Therefore, ChatGPT can automatically generate teaching-related text content. This not only provides the possibility for teachers to edit teaching plans and materials by using ChatGPT but also indicates students can use this tool to finish large-scale writing tasks.

### **II. AI Searching and Respondents**

Intelligent search and answer functions mean that based on a large database, ChatGPT can greatly simplify the processes of information mining, screening, and integration. ChatGPT can display this information in the form of an intelligent language and generate a logical and completed response according to users' questions. With the expansion of the database and continuous optimization of its learning model, this function is gradually showing its absolute advantages over other search engines or literature databases. Now, many postgraduates have used ChatGPT to organize literature reviews.

### **III. Learning Assistance**

Learning assistance function means this kind of generative artificial intelligence can penetrate culture and education, which makes ChatGPT become an artificially intelligent teacher who knows all disciplines and can answer students' questions all the time. Moreover, this special teacher can also help students obtain and understand new information and knowledge. Due to the restriction of database and corpus, the accuracy of this function still needs to be improved, but ChatGPT's systematic organization of original resources still makes it a powerful tool to assist students in broadening their knowledge and deepening their perception.

In the end, ChatGPT has huge potential to revolutionize the way business is taught. It has the potential to radically alter the delivery and absorption of business ideas thanks to its adaptability, personalization, and global collaboration. To create a business education system that is more accessible, effective, and interesting for all students, educators and institutions will need to carefully navigate the integration of ChatGPT and similar technologies, taking into account ethical concerns while taking advantage of AI's transformative potential.

## **QUESTIONNAIRE DESIGN AND DATA ANALYSIS**

The questionnaire is designed for business undergraduate and postgraduate students. The questionnaire has 14 questions, including inquiries about the basic background information of samples, attitude scales, and study habits investigations. The basic background information includes gender, institution, current education and year of study, major breakdown, academic performance, and self-efficacy for learning. The questionnaire was distributed online to 8 Chinese university students in business majors with 162 valid questionnaires collected. The attitude scales are based on the ABC model of attitudes with 15 Likert 5-point scale questions, including three levels of affection, behavior tendency, and cognition. The study habits investigations mainly focus on the number of writing tasks, features of information searching and selecting behaviors, tendencies, and ability of new technology adaptation.

## RESULTS

The opinions and feelings of ChatGpt users are summarized in Table 1. ChatGpt is viewed as a great educational tool by its users, with high percentages stating that it aids in their learning, is fun to watch develop, and can be used in a variety of contexts. Concerns have been raised, however, about the effect it may have on free inquiry and scholastic standards. Users have a positive impression of ChatGpt's interface and its functionality.

Table 1: Students' Perception of ChatGPT (Affection)

Questions	Strongly Disagree %	Disagree %	Agree %	Strongly Agree %	Mean (SD)	Median
ChatGpt is a very helpful helper in my learning process	2.47	5.56	45.06	18.52	3.72	.92
I enjoy witnessing the progress and development of ChatGpt		3.70	50.62	27.16	4.01	.78
I am interested in the application of ChatGpt in different fields	1.23	4.94	51.85	27.16	4.00	.86
As a student, the advent of ChatGpt hindered my spirit of independent exploration (reverse question)	9.88	17.28	28.40	4.94	3.01	1.03
I think ChatGpt's features and application-friendly	1.23	2.47	57.41	16.67	3.86	.76

Source: Author's Calculation

According to the research, a sizable proportion of users (45.06% agree, 18.52% strongly agree) believe ChatGPT is a vital tool in their learning process. The mean score of 3.72 reflects this positive emotion, indicating a generally favorable opinion of ChatGPT's educational aid. The low percentages of strongly disagree (2.47%) and disagree (5.56%) imply that ChatGPT is useful to the majority of users on their learning journey. Furthermore, Students express their delight at seeing ChatGPT progress and development, with a noteworthy 50.62% agreement and 27.16% strong agreement. The average score of 4.01 indicates a high degree of satisfaction. These data support the idea that ChatGPT has enthralled users with its expanding capabilities and contributions.

Interest in the use of ChatGPT in many disciplines is largely favorable, with 51.85% agreeing and 27.16% strongly agreeing. The mean score of 4.00 reflects this passion, demonstrating considerable interest in the potential uses of ChatGPT beyond typical educational environments. ChatGPT is viewed by users as a flexible tool with far-reaching effects.

However, it is important to address the opposite point regarding ChatGPT's influence on the spirit of autonomous discovery. While 28.40% agree and 4.94% strongly agree that ChatGPT impedes autonomous exploration, the majority (27.16% strongly agree and 9.88% agree) disagree. The average score of 3.01 indicates that consumers do not believe ChatGPT stifles their spirit of autonomous discovery. This emphasizes the complex link between AI aid and self-directed learning. Finally, with 57.41% agreement and 16.67% strong agreement, people typically regard ChatGPT's features and application as user-friendly. The mean score of 3.86 demonstrates a favorable assessment of ChatGPT's accessibility and usefulness, which strengthens its value as an educational tool.

The patterns of user behavior are revealed in Table 2. The user's reliance on ChatGpt for educational purposes, such as completing assignments and keeping track of notes, is highlighted. Users talk openly with one another about their time with ChatGpt, and many indicate that they would consider upgrading to the commercial version for more critical projects. In addition, many use ChatGpt to actively seek out information and expand their horizons and expertise.

Table 2: Students' behaviors related to ChatGPT (Behavior tendency)

Questions	Strongly Disagree %	Strongly Agree %	Mean (SD)	Median
During the learning process, I often use ChatGpt to complete homework or other learning tasks	14.20	85.80	.86	.92
I often communicate with other students about my experience of using ChatGpt	11.73	88.27	.88	.78
If necessary, I will use the paid version of ChatGpt for important learning tasks	30.86	69.14	.69	.86
I actively search for how to use ChatGpt and related information	54.32	45.68	.46	1.03
I use ChatGpt to search for new knowledge and information	44.44	55.56	.56	.76

Source: Author's Calculation

Table 2 depicts a snapshot of ChatGpt user behaviors and patterns. According to the research, a large majority of users frequently use ChatGpt to accomplish homework or other learning assignments, with 85.80% agreeing and a minor fraction (0.86%) disapproving. The mean score of 4.86 indicates that ChatGpt is an important part of users' learning processes, acting as a dependable tool for job completion. Furthermore, people actively communicate about their ChatGpt experiences, with 88.27% agreeing and 11.73% disliking. The mean score of 4.88 shows that users are likely to share their ChatGPT-related experiences and ideas with their colleagues. This cooperative component of user behavior emphasizes the social side of technology adoption.

In terms of the possible use of the commercial edition of ChatGpt for key learning activities, 69.14% agree, while 30.86% disagree. The mean score of 3.69 indicates that consumers are willing to explore the premium version for crucial learning requirements, indicating ChatGpt's perceived worth. Users are also proactive in their search for information on how to utilize ChatGpt and associated sites. A significant 54.32% agree, with 45.68% disagreeing. The mean score of 2.46 suggests that users are driven to investigate ChatGpt's features and capabilities, emphasizing their agency in utilizing this medium for learning. Furthermore, 55.56% of users agree and 44.44% disagree that ChatGpt is useful for knowledge and information retrieval. The average score of 2.56 indicates that ChatGpt is a great resource for learning new things and improving one's knowledge base.

Table 3: Attitude and self-efficacy for learning (Cognition)

Questions	Strongly Disagree %	Disagree %	Agree %	Strongly Agree %	Mean (SD)	Median
ChatGpt was able to help me complete a good-quality course essay	11.11	13.58	33.33	6.17	3.72	.92
ChatGpt will effectively shorten my time to search for knowledge and information	3.70	3.70	56.79	12.35	4.01	.78
ChatGpt helps me learn on my own and update my knowledge	5.56	6.17	46.91	9.88	3.99	.86
The knowledge or information provided through ChatGpt is not trustworthy (reverse question)	5.56	11.73	29.01	4.32	3.01	1.03
I think using ChatGpt is against academic norms and ethics (reverse question)	0.09	13.58	21.60	7.41	3.86	.76

Source: Author's Calculation

Table 3 provides useful information on users' cognitive evaluations of ChatGPT. According to the statistics, a sizable proportion of users feel ChatGpt can aid them in creating high-quality course essays, with 33.33% agreeing and 6.17% highly agreeing. In contrast, a tiny proportion of users (11.11% strongly disagree and 13.58% disagree) have reservations regarding ChatGpt's competence in this regard. The mean score of 3.72 suggests that, on average, people feel ChatGpt can help them create great course essays, indicating a good opinion of its skills.

Furthermore, 56.79% of users agree and 12.35% strongly agree that ChatGpt successfully reduces the time they spend searching for knowledge and information. Only a small fraction (3.70% strongly disagree and 3.70% disagree) disagree. The mean score of 4.01 emphasizes ChatGpt's efficiency in information retrieval, emphasizing its significance as a time-saving utility. A sizable majority of users see ChatGpt as a good resource for self-directed learning and knowledge upgrading, with 46.91% agreeing and 9.88% strongly agreeing. While a small fraction (5.56% strongly disagree and 6.17% disagree) disagrees, the mean score of 3.99 highlights ChatGpt's importance in fostering autonomous learning.

However, it is worth mentioning that a sizable proportion of users do not trust the expertise or information offered by ChatGpt, with 29.01% agreeing and 4.32% strongly agreeing. In contrast, 5.56% strongly disagree and 11.73% disagree with this statement. The mean score of 3.01 illustrates people's mixed feelings about ChatGPT's dependability in delivering information. In terms of academic standards and ethics, just a small proportion (0.09% strongly disagree and 13.58% disagree) feel that utilizing ChatGpt violates these values and ethics. This is a worry shared by a larger proportion of people (21.60% agree and 7.41% strongly agree). The mean score of 3.86 indicates that users agree on the possible ethical issues of using ChatGpt in an academic setting.

Overall, users see ChatGpt as a useful educational tool that has benefited their learning, fostered a more collaborative mindset, and increased productivity.

## DISCUSSIONS

For most business students, ChatGPT is undoubtedly a new thing. In this survey, more than 60% of students did not hear or learn about ChatGPT for the first time until after 2023. At the same time, limited by information channels or limited direct experience, it is not surprising that students have some incomplete and inaccurate knowledge of ChatGPT. In the survey, we found that students overall were optimistic about ChatGPT. Most students have shown a strong interest in the functions and



applications of ChatGPT, and have begun to conceive and try to use ChatGPT to complete academic tasks - at least half of the students will actively search for the use of ChatGPT and related information; About 1/3 of students already use ChatGPT to complete assignments or other learning tasks and exchange experiences with other students.

However, these behaviors are based on incomplete, inaccurate perceptions of ChatGPT. Many students believe that the function of ChatGPT is not only to effectively shorten the time to retrieve knowledge and information but also to directly help them complete some learning tasks, such as a course paper. This misunderstanding of ChatGPT's function may be a challenge for business courses. If students are not curbed from abusing ChatGPT for assignments or graduation theses, the output of business education will be fundamentally questioned. It's also a caveat that according to our survey, only about 30% of students believe that using ChatGPT to complete learning tasks may violate academic ethics and integrity.

In fact, due to the limitations of ChatGPT's current stage of development, it often gives some false or wrong information. Only 1/3 of students realized that the information provided by ChatGPT was not completely reliable, and 56% of students believed that ChatGPT could help them update their knowledge. As a result, students are likely to be misled by ChatGPT's inaccurate and even biased responses, posing new challenges to teachers' authority in the classroom.

On the other hand, the profound impact of ChatGPT on business education may be even more disruptive. Since ChatGPT has been used in many industries, such as advertising copywriting, interview simulation, product development brainstorming, etc. This also means that in future business education, the application ability of ChatGPT must not be lacking. Not only that, all AI-related knowledge and application capabilities are a topic that cannot be avoided in future business education. Therefore, the emergence of ChatGPT not only puts forward new requirements for the content of future business education but also puts forward higher standards for teachers' technical adaptability. For today's business educators, it is important to design and develop an effective and up-to-date curriculum at this time. These necessary pedagogical reforms are a response to business practice and reflect a reality facing business education – that is, business model innovation and development led by technological innovation are becoming more and more obvious faster than theoretical development and updating in academies. Therefore, even without ChatGPT, business education will eventually be challenged by other technological advances or new forms of business.

## CONCLUSION

ChatGPT is also helpful for users in terms of independent study and information refreshment. However, questions are raised about the veracity of the information or expertise offered by ChatGPT. Concerns about the morality of using ChatGPT in the classroom are generally shared by its users. There are, however, concerns regarding the information's veracity and ethical implications. ChatGPT's function in the educational environment, including its potential benefits and limitations, may be better understood by looking at the interplay between user attitudes, behaviors, and cognitive perspectives.

First, the emergence of ChatGPT does pose a strong challenge to the content and practice of business education. Keeping knowledge updated will become the top priority for teachers – teachers' development must be premised on keeping knowledge updated, which may be a positive stimulus.

Second, the evaluation mechanism of business education needs to be upgraded or reconstructed. Perhaps the use of technical means to intervene in the inspection and review of students' work and results will become the norm. Discussing and developing reasonable ethical standards – such as when using ChatGPT in learning progress is not illegal – will become crucial.

Finally, with the addition of more comprehensive databases, corpora, and the development of educational uses, perhaps ChatGPT will become a useful supplement and helper in the educational process in the future.

## REFERENCES

- Anders, B.A. (2022a), "ChatGPT (AI) in education – an overview", *American University of Armenia*. Available at: <https://drive.google.com/file/d/1fTtmGz2Cp2nd65mNfQzPyo3beWXc9j9m/view> (accessed 10 February 2023).
- Gilson, A., Safranek, C., Huang, T., Socrates, V., Chi, L., Taylor, R.A., & Chartash, D. (2023). "How well does ChatGPT do when taking the medical licensing exams? The implications of large language models for medical education and knowledge assessment", *JMIR Medical Education*, 9, e45312. doi: 10.2196/45312.
- Floridi, L., & Chiriatti, M. (2020). GPT-3: Its nature, scope, limits, and consequences. *Minds and Machines*, 30(4), 681–694.
- Haque, M.U., Dharmadasa, I., Sworna, Z.T., Rajapakse, R.N., & Ahmad, H. (2022). "I think this is the most disruptive technology: exploring sentiments of ChatGPT early adopters using Twitter data", *arXiv*. doi: 10.48550/arXiv.2212.05856.
- Stokel-Walker, C. (2023), "ChatGPT listed as author on research papers: many scientists disapprove", *Nature*, 613, 620-621. Available at: <https://www.nature.com/articles/d41586-023-00107-z>
- Li, Y., Choi, D., Chung, J., Kushman, N., Schrittwieser, J., Leblond, R., Eccles, T., Keeling, J., Gimeno, F., & Dal Lago, A. (2022). "Competition-level code generation with alphacode", *Science*, 378(6624), 1092-1097.
- Stokel-Walker, C. (2023), "ChatGPT listed as author on research papers: many scientists disapprove", *Nature*, 613, 620-621. Available at: <https://www.nature.com/articles/d41586-023-00107-z>

- Topsakal, O., & Topsakal, E. (2022), "Framework for A Foreign language teaching software for children utilizing AR, voicebots and ChatGPT (large language models)", *The Journal of Cognitive Systems*, 7(2), 33-38.
- Vanian, J. (2022), "Why tech insiders are so excited about ChatGPT, a chatbot that answers questions and writes essays", *CNBC*. Available at: <https://www.cnn.com/2022/12/13/chatgpt-is-a-new-ai-chatbot-thatcan-answer-questions-and-write-essays.html>

**This page is the spine page. Please remove it before printing this book.**

**Note from ICEB Home Office:**

The *ICEB* is a diamond open access journal. Users and publishers are welcome to produce a printed copy of the *ICEB* using this document under the license of

*Creative Commons Attribution-NonCommercial\_4.0 International (CC BY-NC 4.0).*



**Guides for Book Printing:**

The content of this book uses Times New Roman and Calibri fonts. For book printing, the front cover uses the first page, while the back cover uses the last page. This spine page and the two book covers can be printed on a white-color heavy-duty A3-size paper to produce the cover pages for this book. This page is available in DOCX at: <https://iceb.johogo.com/proceedings/2023/ICEB-2023-spine-V.docx>

# Sponsors

